



جزوه آموزشی موتور و گیربکس MVM 110S



Code: ELC-81-04

جزوه آموزشی موتور و گیربکس خودرو

MVM 110 S

بخش اول

موتور

کلیات موتور

Item	Specification	
Type	Vertical, in-line 3-cylinder, water-cooled, 4-stroke, DOHC	
Engine Type	SQR371F	
Cylinder Diameter (mm)	71	
Piston Stroke (mm)	83.9	
Displacement (ml)	998	
Compression Ratio	11:1	
Fuel Supply Type	Electronic controlled sequential multiport fuel injection	
Combustion Chamber Type	Basin cone compound type	
Ignition Sequence	1 - 2 - 3	
Idle Speed (r/min)	850 ± 50	
Idle Stability	≤ 20%	
Rated Power (kW)	51	
Rated Power Speed (r/min)	6000	
Max. Torque (N·m)	93	
Max. Torque Speed (r/min)	3500 ~ 4500	
Min. Fuel Consumption Rate (Total Output) (g/kW·h)	270	
Oil and Fuel Consumption Percentage	≤ 0.15	
Crankshaft Rotation Angle (°) With Intake Valve Open of 1 mm	374.5	
Crankshaft Rotation Angle (°) With Intake Valve 1 mm Before Close	567	
Crankshaft Rotation Angle (°) With Exhaust Valve Open of 1 mm	141.5	
Crankshaft Rotation Angle (°) With Exhaust Valve 1 mm Before Close	343	
Net Weight (kg)	98	
Fuel Octane Number (Not Less Than)	Unleaded gasoline, octane number 93	
Oil Capacity (L)	2.80 ± 0.2	
Oil Octane Number	Summer	SAE 10W-40 (SM or higher)
	Winter	SAE 5W-40 (SM or higher)
	Full year	SAE 5W-30 (SM or higher)
Crankshaft Rotation Direction	Clockwise (viewed from engine V-ribbed belt)	

Item	Specification	
Starting Method	Electrical Starting	
Cooling Type	Forced circulation type antifreeze cooling	
Coolant Type	50% glycol + 50% soft water (volume ratio)	
Lubrication Type	Compound type (pressure, splash lubrication)	
Cylinder Compression Pressure (MPa)	1.00 ~ 1.35	
Oil Pressures (kPa)	Low idling speed (800 ± 50 r/min)	120 - 150
	High Idle Speed (2000 r/min)	320 - 350
	High Speed (4000 r/min)	370 ± 50
Thermostat Operation Temperature (°C)	Open Temperature	82 ± 2
	Full Open Temperature	95
Boundary Dimension (Length × Width × Height) (mm)	331 × 535 × 709	
Electronic Fuel Injection System	S15 1.0L MT model	UAES electronic control system
Starting Performance	With the atmospheric temperature at -30°C, the engine can start smoothly within 8 seconds without taking special measures. Starting test can be performed 3 times consecutively. If it fails to start, perform starting again after 2 minutes.	

جدول مشخصات فنی موتور

Item		Specification	
Camshaft	Cam Height (mm)	Intake Cam	41.512
		Exhaust Cam	40.302
	Camshaft Journal (mm)	First Intake Camshaft Journal	$\phi 34_{-0.050}^{-0.066}$
		Other Intake Camshaft Journal	$\phi 23_{-0.040}^{-0.053}$
		First Exhaust Camshaft Journal	$\phi 26_{-0.040}^{-0.053}$
		Other Exhaust Camshaft Journal	$\phi 23_{-0.040}^{-0.053}$
	Camshaft Axial Clearance (mm)	Intake Cam	0.125 - 0.225
		Exhaust Cam	0.125 - 0.225
Cylinder Head	Lower Surface Flatness (mm)		0.04
	Overall Height (mm)		113 ± 0.05
	Max. Grinding Amount of Cylinder Head (mm)		0.15
	Max. Total Grinding Amount of Cylinder Block and Cylinder Head		0.20

Item		Specification	
Valve	Valve Head Margin Thickness (mm)	Intake Valve	0.3 ± 0.15
		Exhaust Valve	0.3 ± 0.15
	Valve Lifter Diameter (mm)	Intake Valve	$\phi 5.5 \pm 0.2$
		Exhaust Valve	$\phi 5.5 \pm 0.2$
	Seal Band Width (mm)	Intake Valve	1.402
		Exhaust Valve	1.256
	Clearance Between Valve Lifter and Guide (mm)	Intake Valve	0.038 - 0.053
		Exhaust Valve	0.048 - 0.063
	Inclination Angle	Intake Valve	16.4°
		Exhaust Valve	17.1°
Height (mm)	Intake Valve	88.5	
	Exhaust Valve	89.2	
Valve Spring	Free Height (mm)	52	
	Height Under 256 N Pressure (mm)	26.4	
	Perpendicularity	1.3	
Valve Guide	Valve Guide Length (mm)	34.7 ± 0.1	
	Inner Diameter (mm)	$\phi 5 + 0.018$	
	Outer Diameter (mm)	$\phi 10^{+0.066}_{+0.055}$	
	Depression Depth	Intake	10 ± 0.2
		Exhaust	9.5 ± 0.2
Valve Lifter Protrusion Amount (mm)	Intake Valve	34.17	
	Exhaust Valve	34	
Piston Ring	Side Clearance (mm)	First Ring	0.03 - 0.07
		Second Ring	0.02 - 0.06
	End Clearance (mm)	First Ring	0.2 - 0.35
		Second Ring	0.4 - 0.55
	Back Clearance (mm)	First Ring	0.7 - 1.1
		Second Ring	0.7 - 1.1
	Height (mm)	First Ring	$1.0^{+0.01}_{-0.03}$
Second Ring		$1.0^{+0.01}_{-0.03}$	
Oil Ring		$1.5^{+0.02}_0$	
Piston Ring Groove	Height (mm)	First Ring	$1.0^{+0.01}_{-0.02}$
		Second Ring	$1.0^{+0.03}_{+0.01}$
		Oil Ring	$1.5^{+0.03}_{+0.01}$
Piston Pin	Diameter (mm)	$\phi 18^{+0.001}_{-0.005}$	
	Length (mm)	47 ± 0.2	
	Piston Pin Hole Diameter (mm)	$\phi 18^{+0.007}_{+0.002}$	

Item		Specification	
Piston	Cylinder 1 Piston Diameter (mm)	$\phi 71_{-0.022}^{-0.01}$	
	Cylinder 2 Piston Diameter (mm)	$\phi 71_{-0.022}^{-0.01}$	
	Cylinder 3 Piston Diameter (mm)	$\phi 71_{-0.022}^{-0.01}$	
Crankshaft	Crankshaft Main Journal (mm)	Diameter	$\phi 44_{-0.020}^{-0.004}$
		Coaxially	0.05
		Cylindricity	0.008
		Roundness	0.005
	Connecting Rod Journal (mm)	Diameter	$\phi 40_{-0.020}^{-0.004}$
		Parallelism to Main Journal	0.006
Radial Clearance (mm)		0.020 - 0.065	
Cylinder Block	Overall Height (mm)	257 ± 0.05	
	Bore Diameter (mm)	$\phi 71.025$	
	Bore Roundness/Straightness (mm)	0.008/0.01	
	Upper Surface Flatness (mm)	0.04	
	Max. Grinding Amount of Cylinder Block (mm)	0.15	
	Max. Total Grinding Amount of Cylinder Block and Cylinder Head	0.20	
Connecting Rod	Connecting Rod Shell Radial Clearance (mm)	0.034 - 0.066	
	Big End Axial Clearance (mm)	0.15 - 0.37	

فشار سوخت

SQR371F	Pressure (kPa)
Fuel Pressure on Fuel Rail - Key II (ON)	350
Fuel Pressure on Fuel Rail - Engine Idling	400
Fuel Pressure on Fuel Rail - Key B (LOCK)	350

ظرفیت مایع خنک کننده

Item	Capacity (L)
Cooling System	4.4 ± 0.2

مشخصات سیستم روغن کاری

Condition	Pressure (kPa)
Low Idling Speed (800 ± 50 r/min)	120 - 150
High Idling Speed (2000 ± 50 r/min)	320 - 350
High Speed (4000 r/min)	370 ± 50

Engine Oil Specifications

Engine Type	SQR371F
Oil Capacity (L)	2.8 ± 0.2

مشخصات دهانه شمع

Spark Plug Gap (mm)	0.8 - 0.9
---------------------	-----------

ابزارهای مخصوص

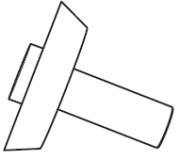
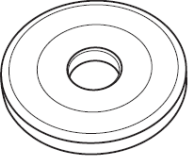
Crankshaft Rear Oil Seal Installation Guide	 <p>RS15000093</p>
Crankshaft Front Oil Seal Installer	 <p>RS15000095</p>

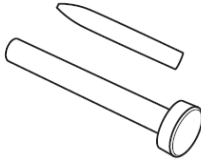
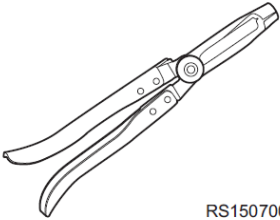
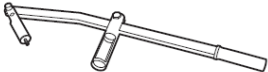
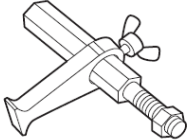
Valve Oil Seal Installer	 <p>RS1500098</p>
Valve Oil Seal Pulling Plier	 <p>RS1507006</p>
Valve Spring Compressor	 <p>RS1500094</p>
Flywheel Holding Tool	 <p>RS15071002</p>

جهت بررسی ابزار مخصوص ها به لیست SPECIAL TOOLS مراجعه کنید.

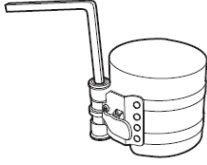
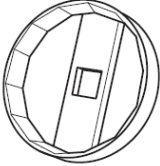
<p>Piston Installer</p>	 <p>RS15000097</p>
<p>Oil Filter Remover</p>	 <p>RS15130030</p>

زنجیر تایم و اجزای آن

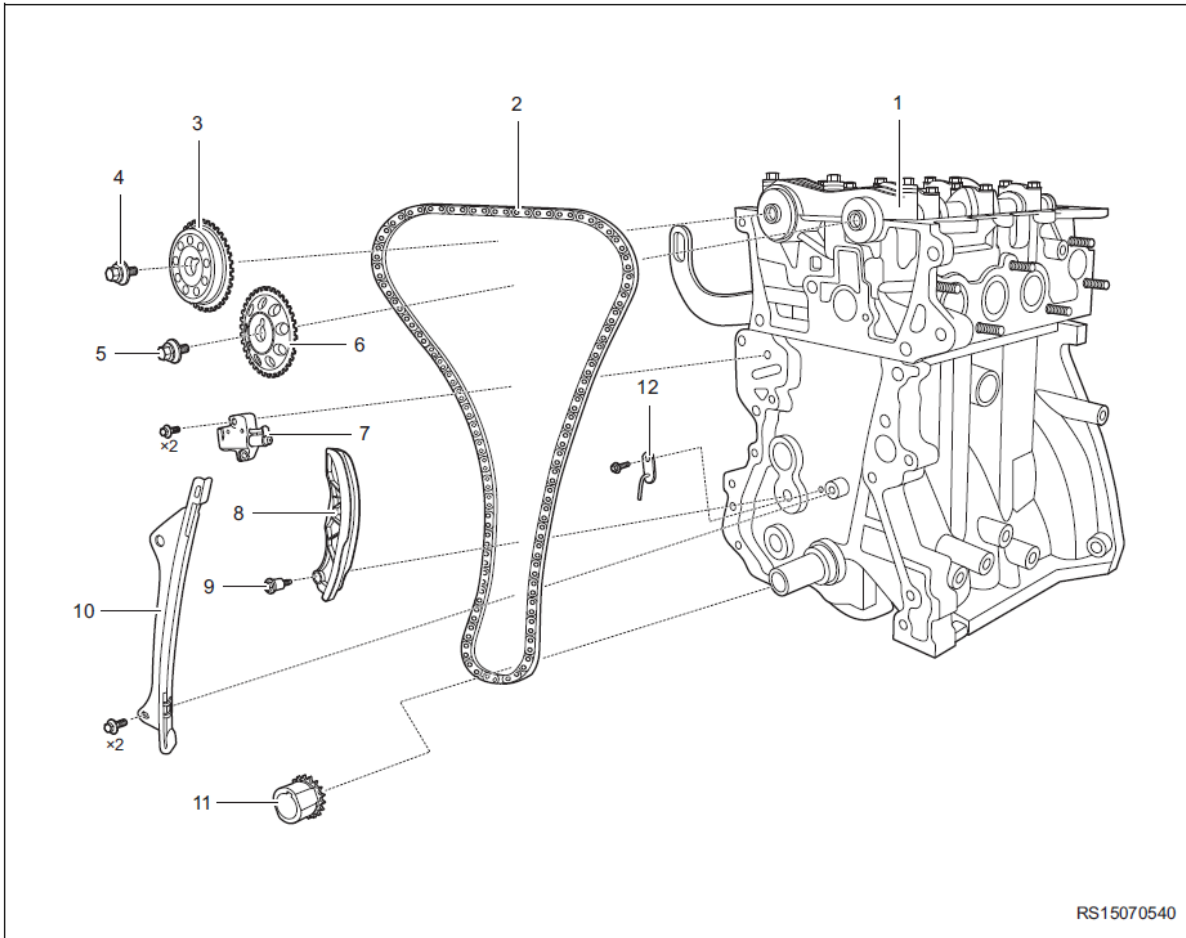

RS15070540

1 - Engine Assembly	2 - Timing Chain
3 - Intake Camshaft Sprocket	4 - Intake Camshaft Sprocket Fixing Bolt
5 - Exhaust Camshaft Sprocket Fixing Bolt	6 - Exhaust Camshaft Sprocket
7 - Tensioner	8 - Movable Guide Rail
9 - Movable Guide Rail Fixing Bolt	10 - Fixing Guide Rail
11 - Crankshaft Timing Sprocket	12 - Timing Chain Nozzle

مراحل بازوبست زنجیر تایم و اجزای آن

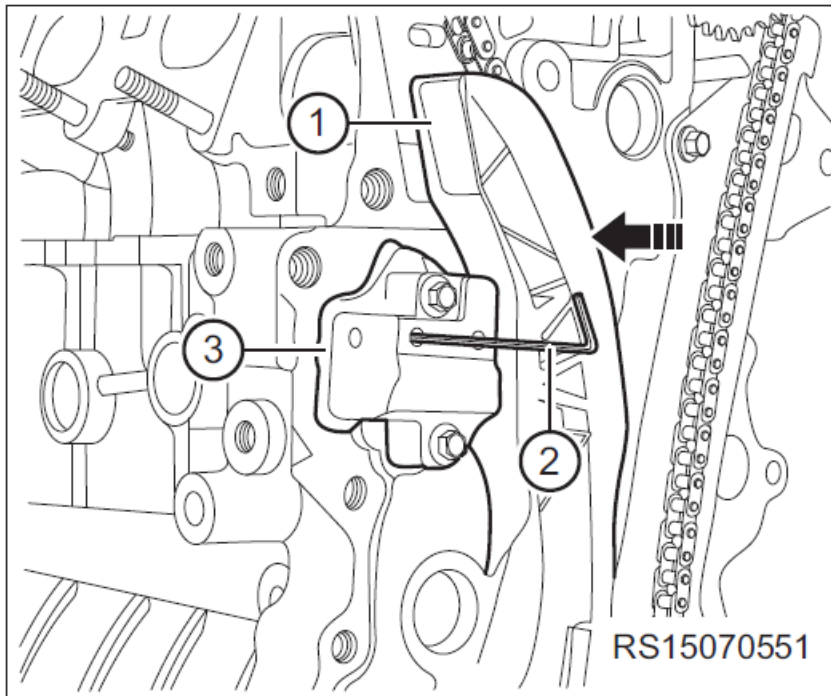

ابتدا زنجیر سفت کن را به عقب فشار دهید و یک پین را درون آن قفل کنید.

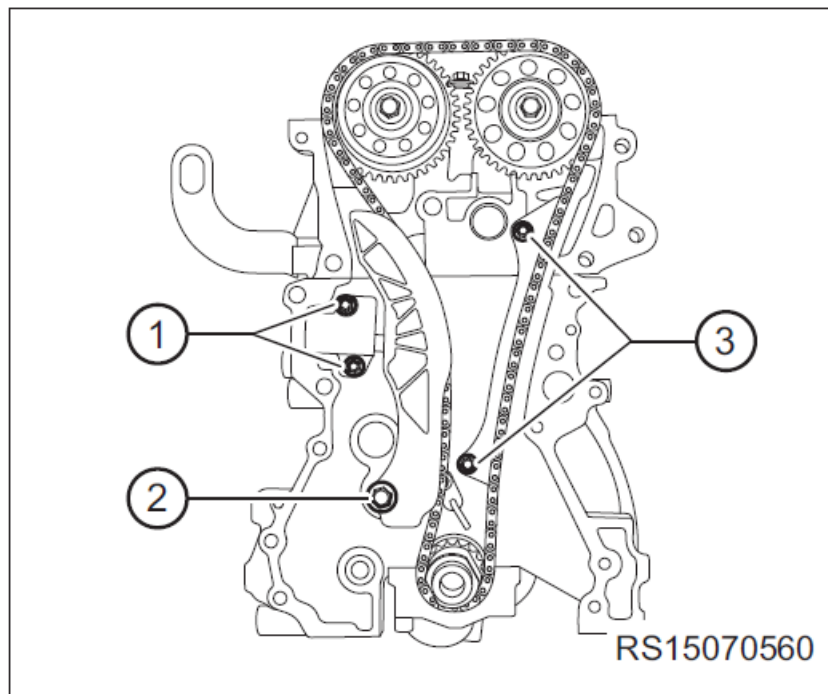

پیچ قاب راهنمای ثابت و متحرک را باز کنید و زنجیر را آزاد کنید. جلو و پشت زنجیر را علامت بزنید.

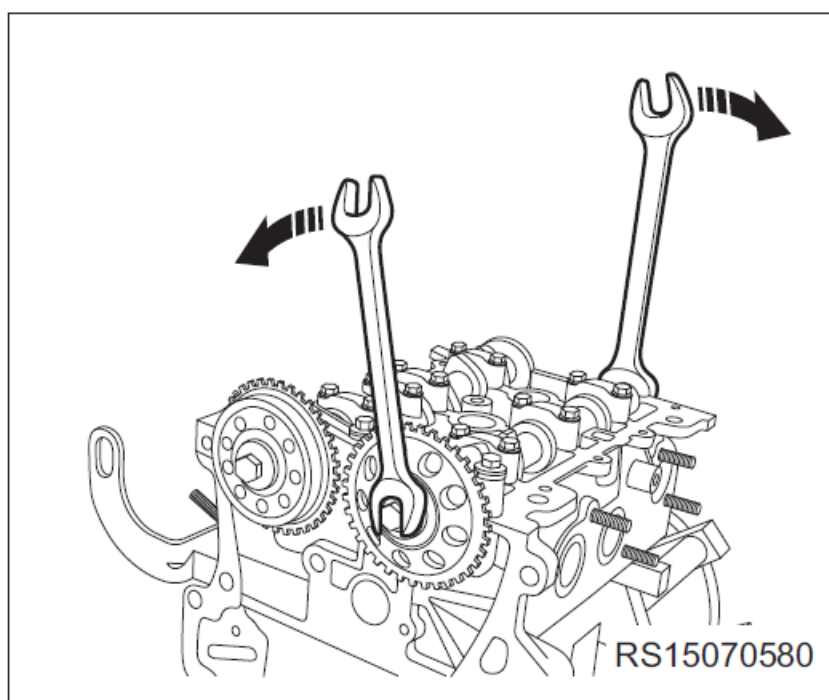
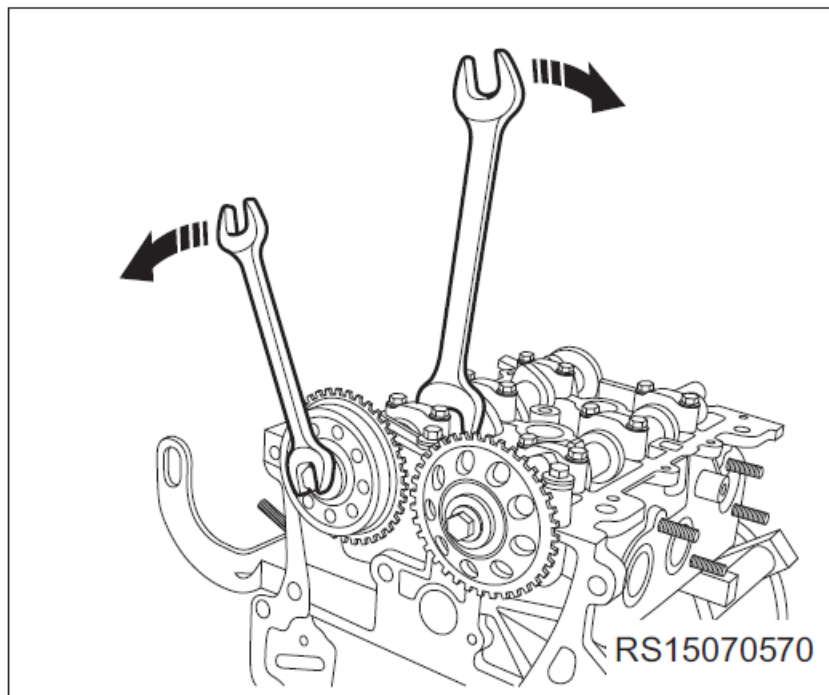

چرخنده میل سوپاپ هوا و دود را باز کنید.

گشتاور باز و بست پیچ چرخنده میل سوپاپ 55 N.m است.

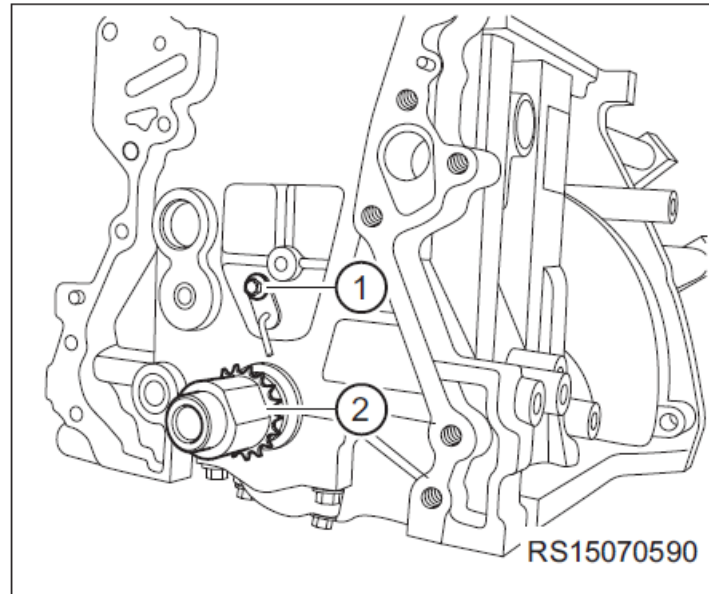

نازل روغن زنجیر تایم را باز کنید.

- زنجیر تایم در صورت نداشتن سایش مشخص و یا ترک قابل استفاده مجدد است.
- قاب راهنمای ثابت و متحرک را کنترل نمایید. در صورت داشتن سایش، آنها را تعویض نمایید.

نحوه تایم کردن موتور

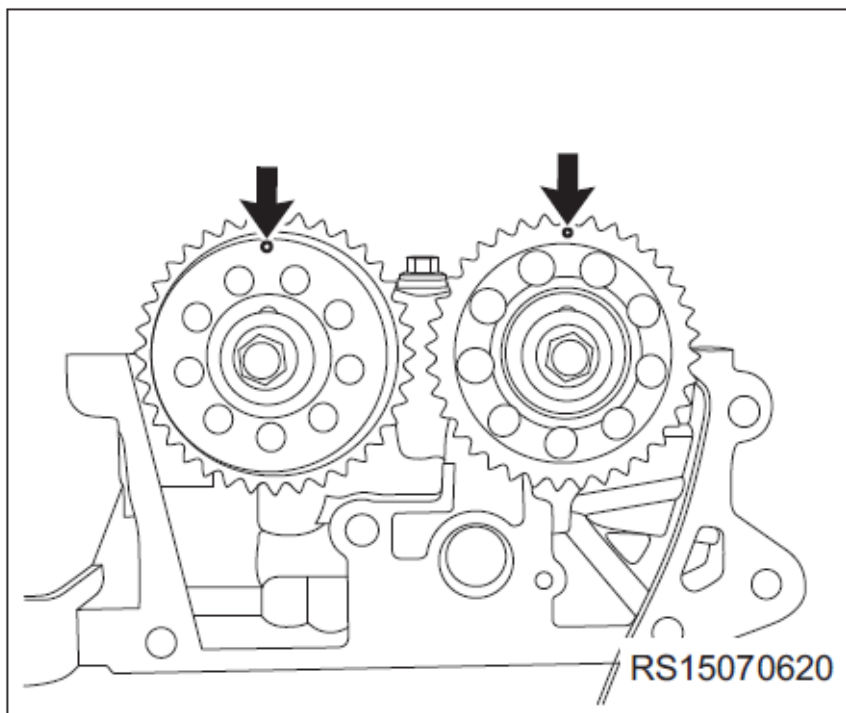

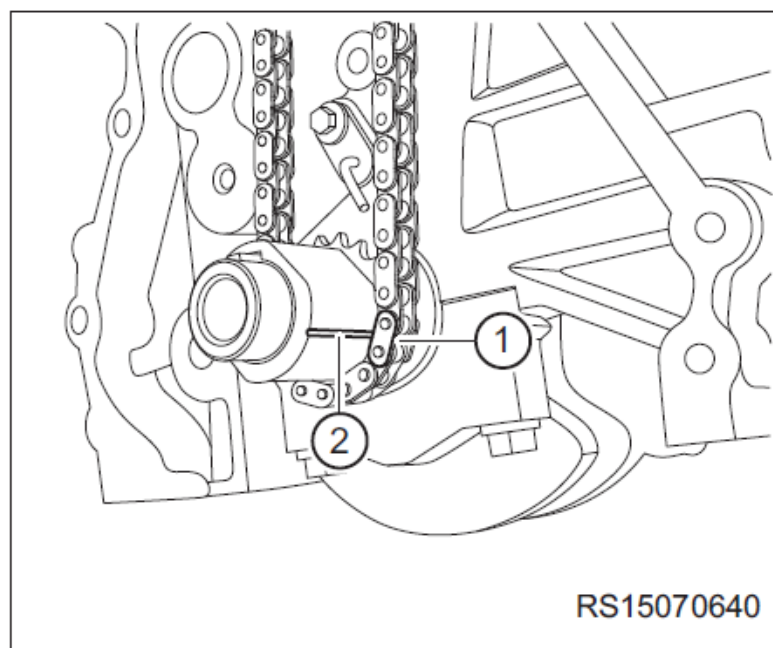
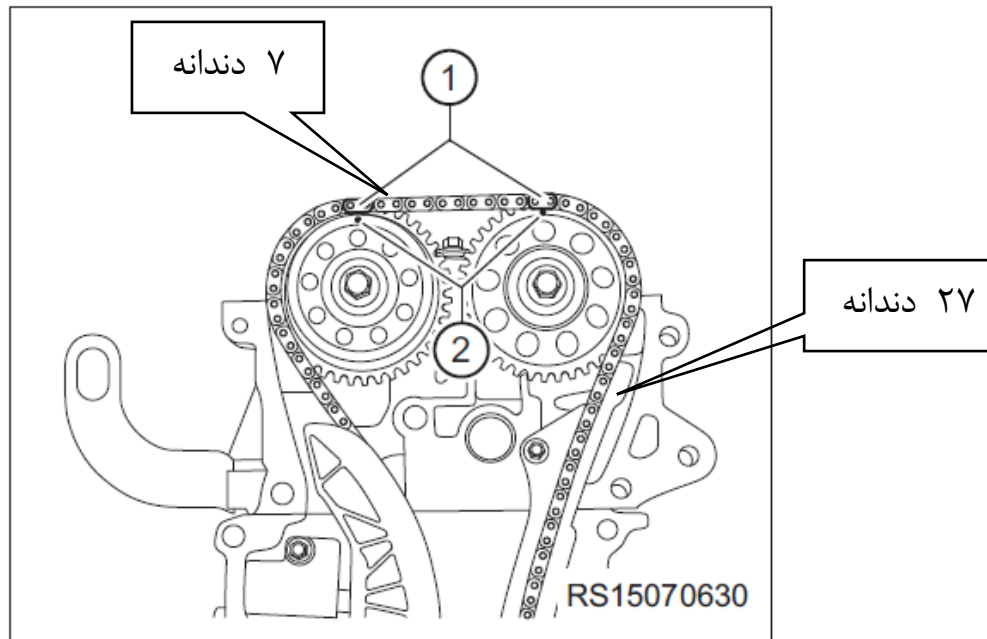

روش تایم کردن موتور را مطابق توضیحات داده شده به صورت کامل بنویسید.

لقی طولی میل سوپاپ

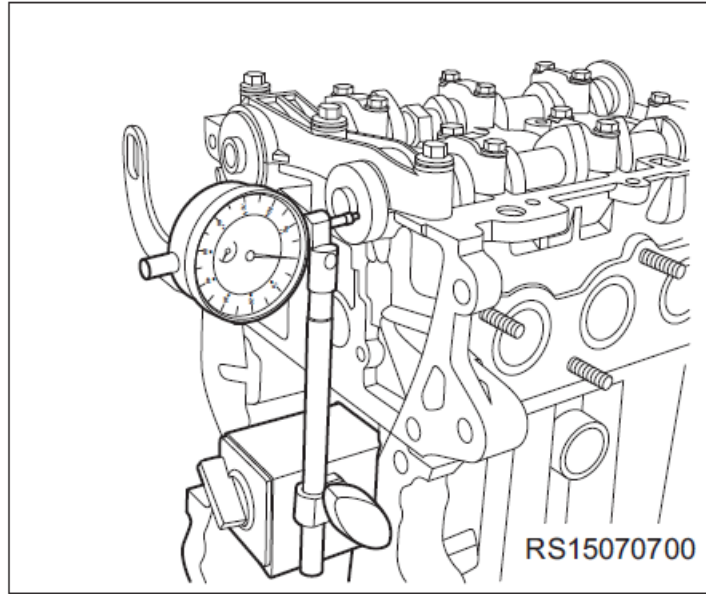

Measurement Item		Specification (mm)
Camshaft Thrust Clearance	Intake Cam	0.125 - 0.225
	Exhaust Cam	0.125 - 0.225

- بستن پیچ های کپه میل سوپاپ (گشتاور 10 N.m)

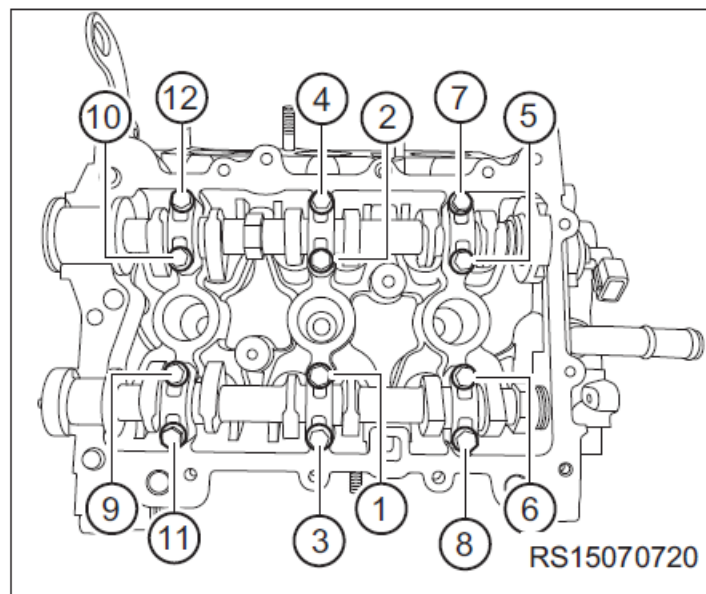

باز و بست پیچ های شاتون

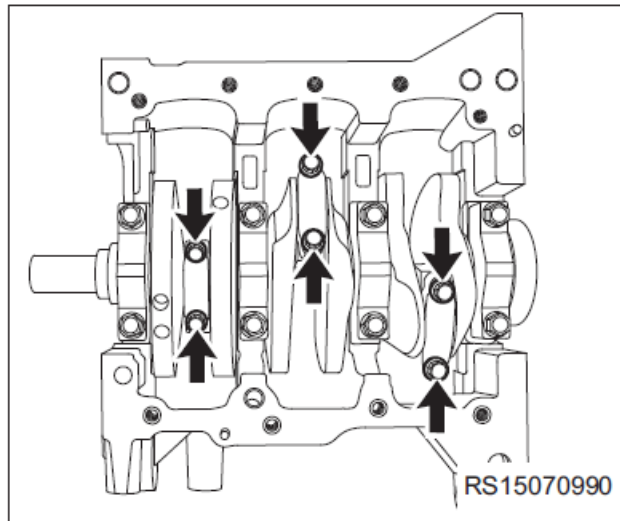

- گشتاور بستن پیچ های شاتون: 14 - 16 N.m + 55-65 deg

مونتاژ شاتون در پیستون

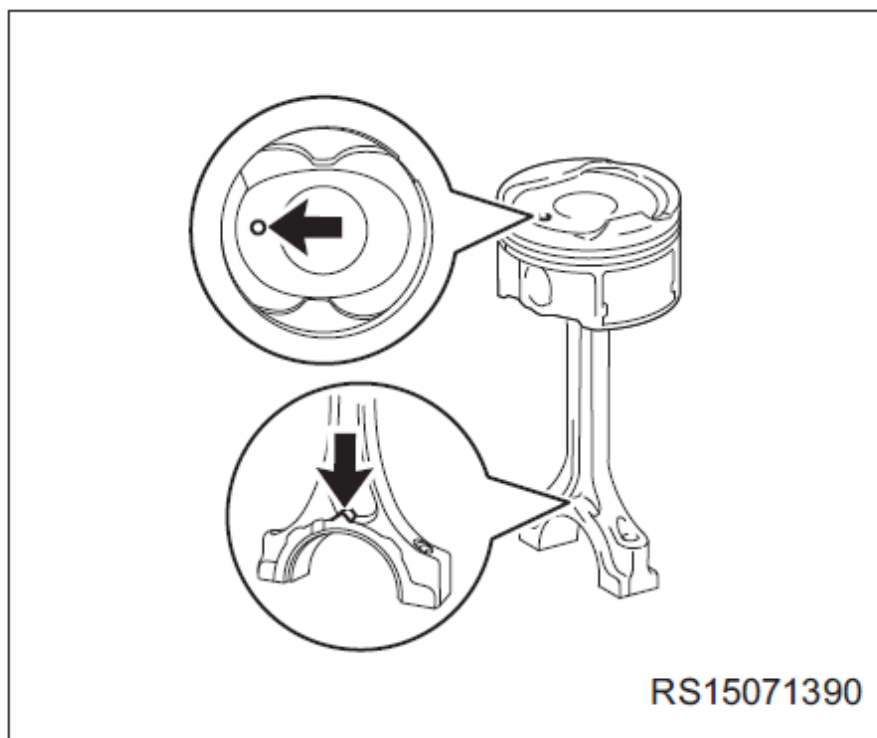

محل قرارگیری بغل یاتاقانی

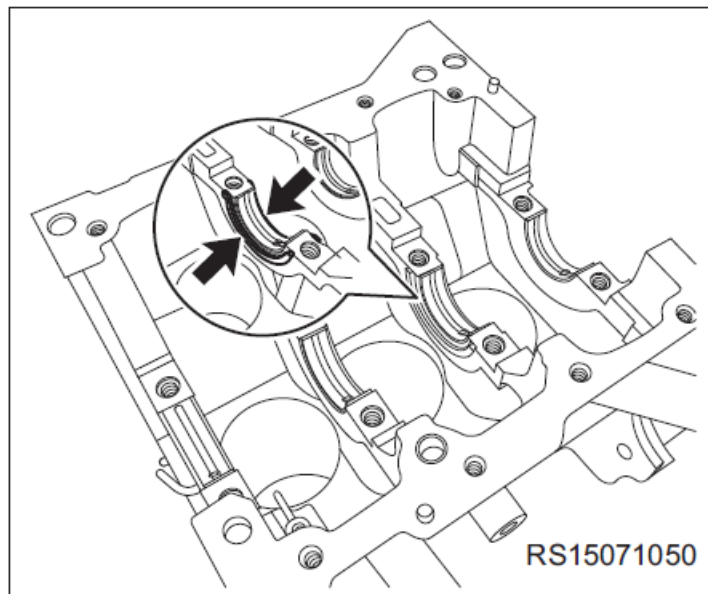

نحوه روغن کاری جداره داخلی سیلندر

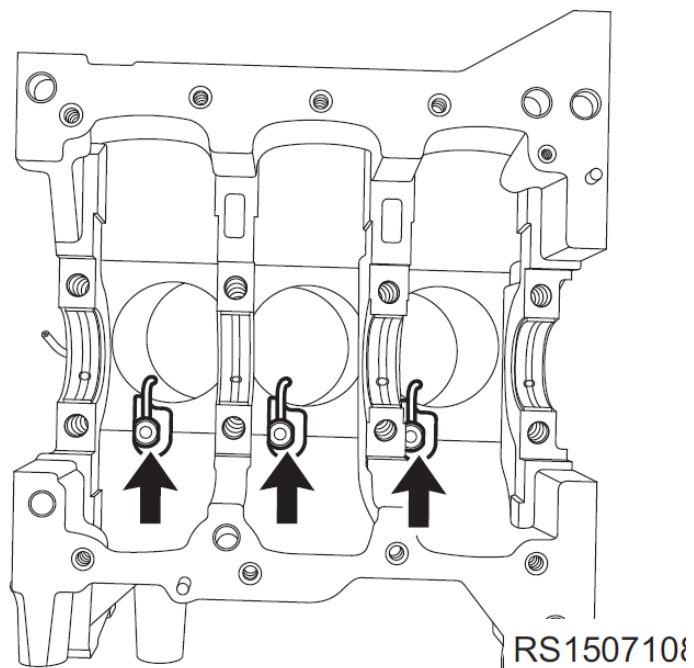

تست لقی طولی شاتون

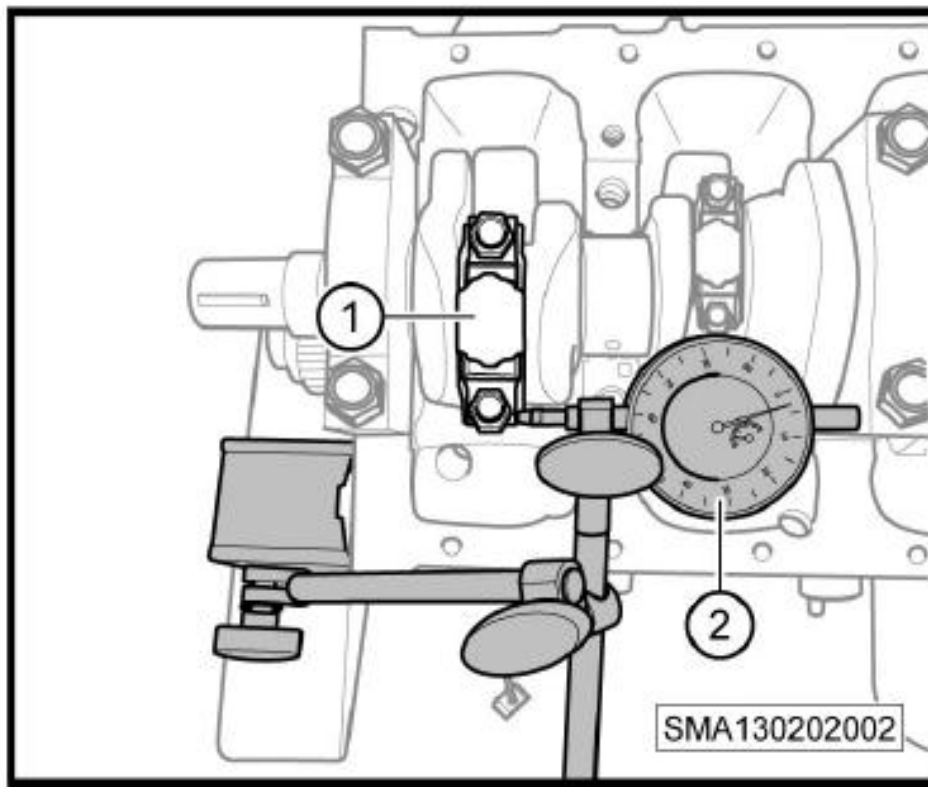

مقدار مجاز: $0.36 \pm 0.027 \text{ mm}$

نحوه اندازه گیری را بنویسید.

تست سایش میل لنگ

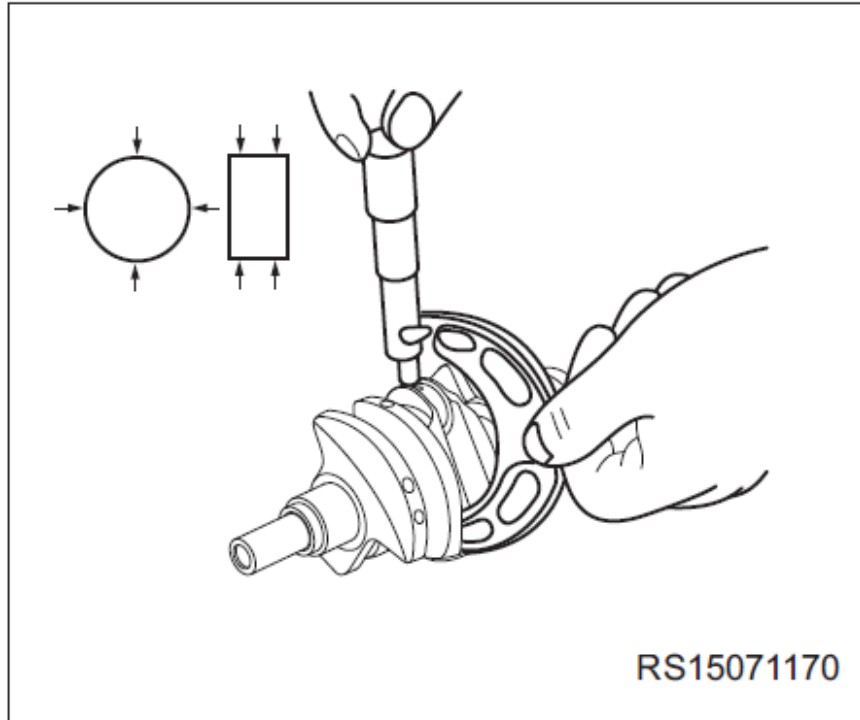

Measurement Item	Specification (mm)
Connecting Rod Journal Diameter	$\phi 40_{-0.020}^{-0.004}$

تست لقی شعاعی شاتون

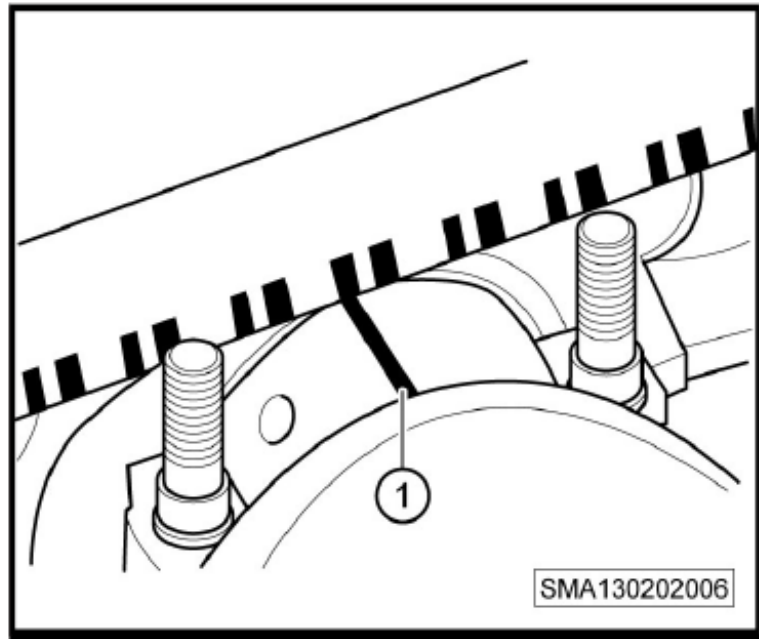

مقادیر مجاز

Measurement Item	Specification (mm)
Connecting Rod Bearing Shell Radial Clearance	0.034 - 0.066

نحوه اندازه گیری را توضیح دهید.

تست لقی طولی شاتون

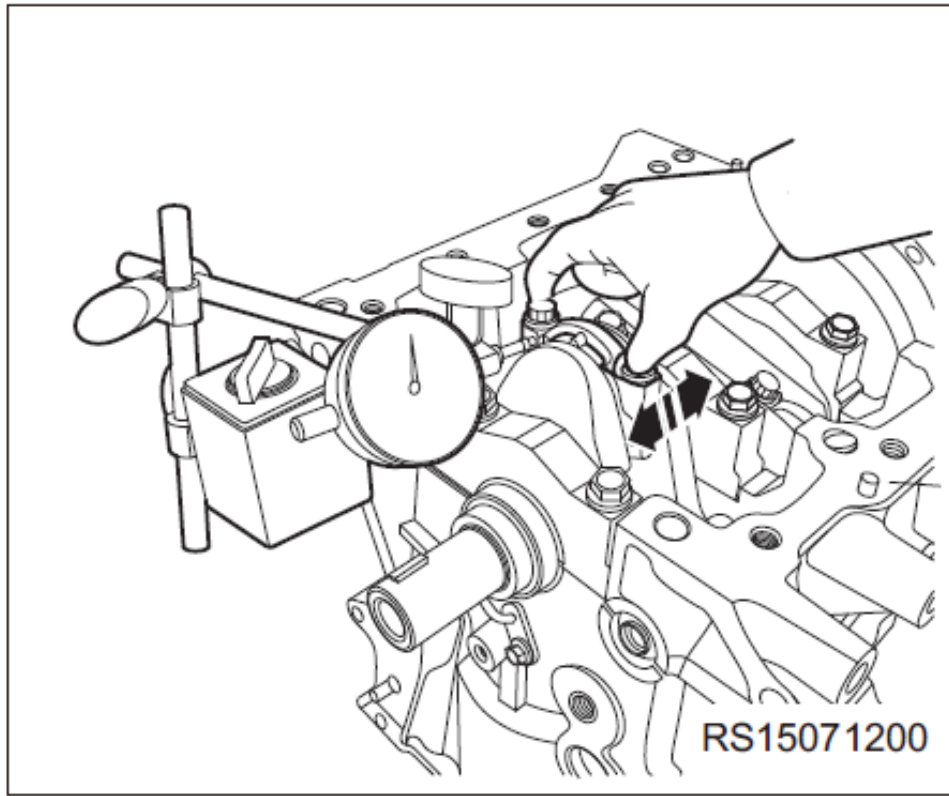

Measurement Item	Specification (mm)
Connecting Rod Axial Clearance	0.15 - 0.37

تست لقی طولی میل لنگ

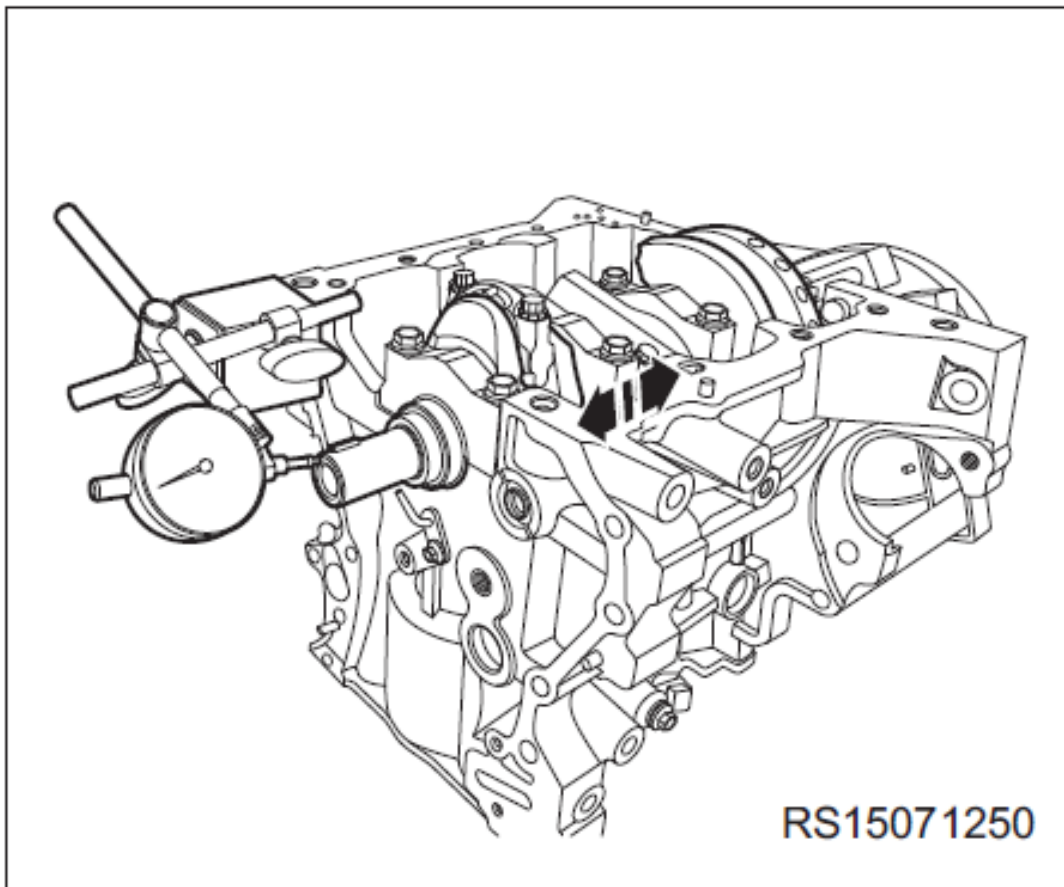

Measurement Item	Specification (mm)
Crankshaft Axial Clearance	0.08 - 0.28

تست تاب میل لنگ

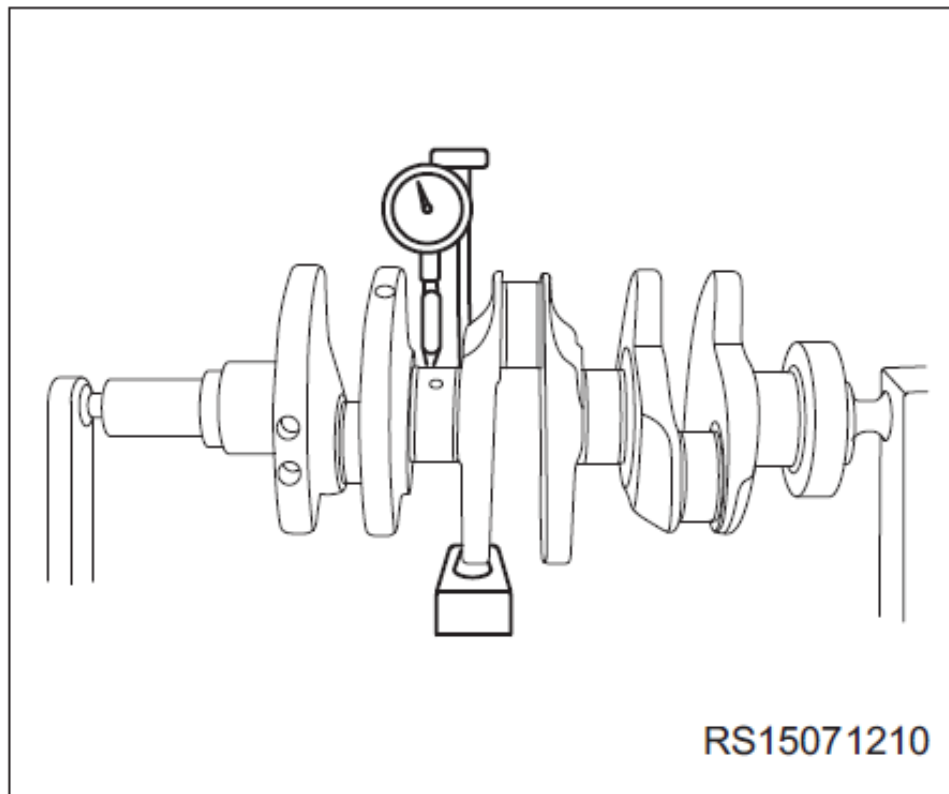

Measurement Item	Specification (mm)
Crankshaft Main Journal Coaxiality	0.05

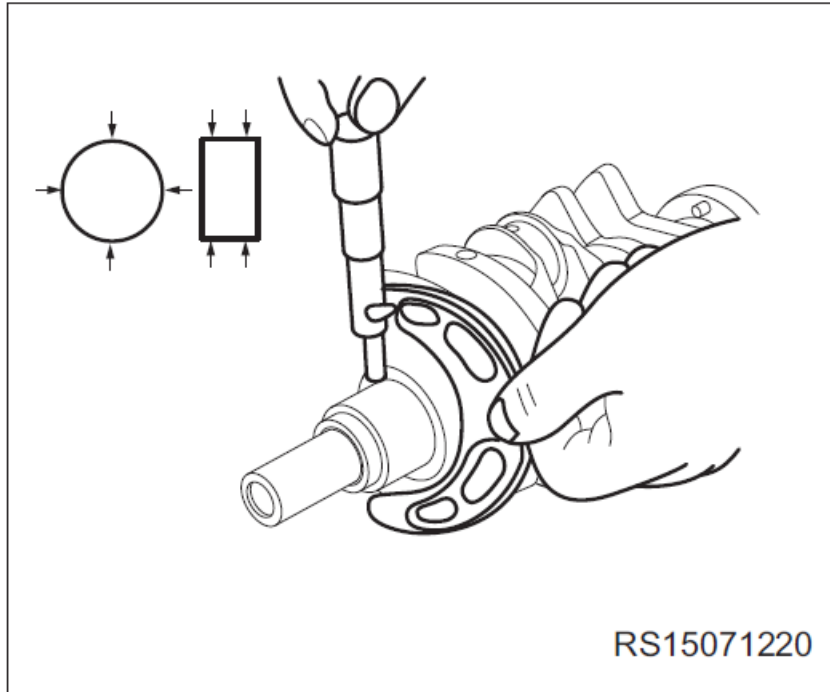

$$\text{Roundness} = (\text{maximum diameter} - \text{minimum diameter})/2$$

Measurement Item		Specification (mm)
Crankshaft Main Journal	Cylindricity	0.008
	Roundness	0.005

تست لقی شعاعی ثابت

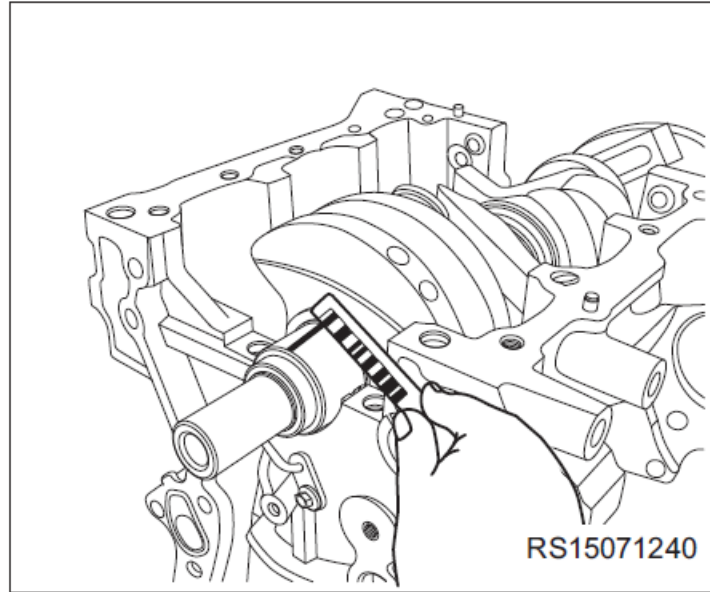

Measurement Item	Specification (mm)
Crankshaft Radial Clearance	0.020 - 0.065

ابزار مخصوص رینگ درآر

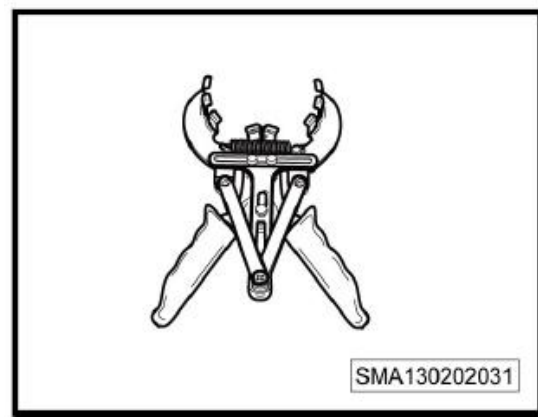
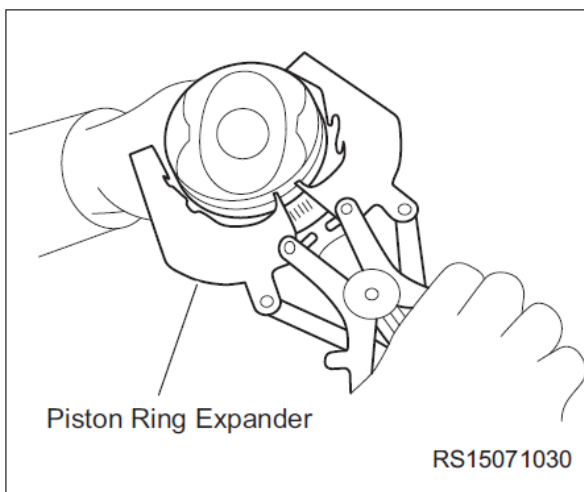

Piston ring remover

موقعیت دهانه رینگ ها در پیستون:

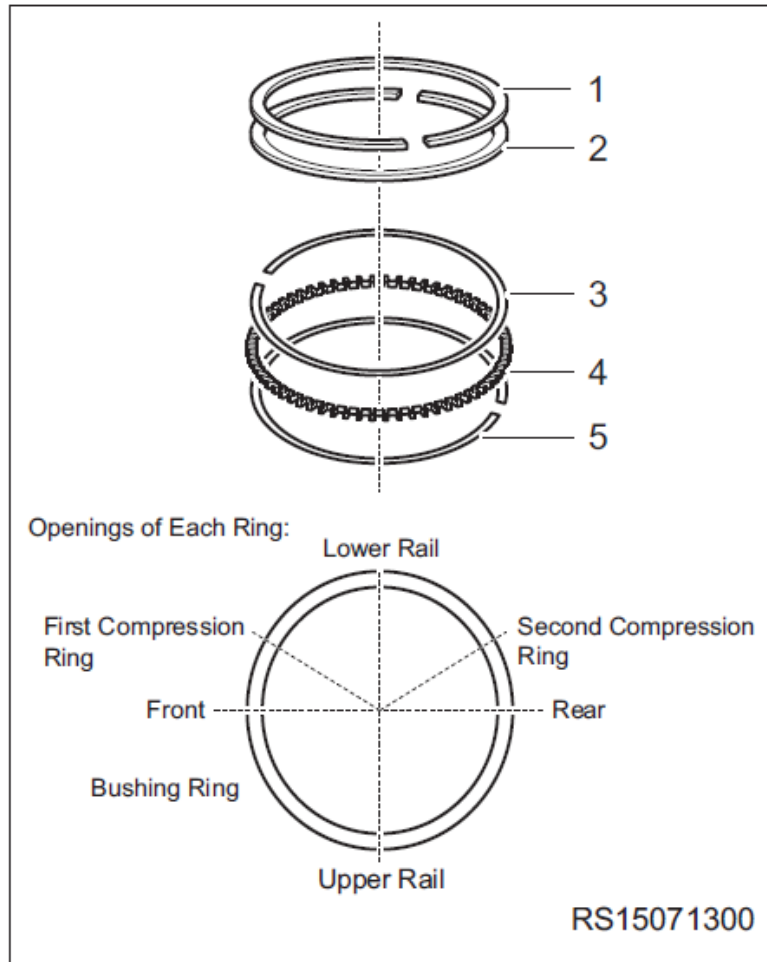

شرایط تنظیم دهانه رینگ ها را بنویسید

اندازه گیری قطر پیستون:

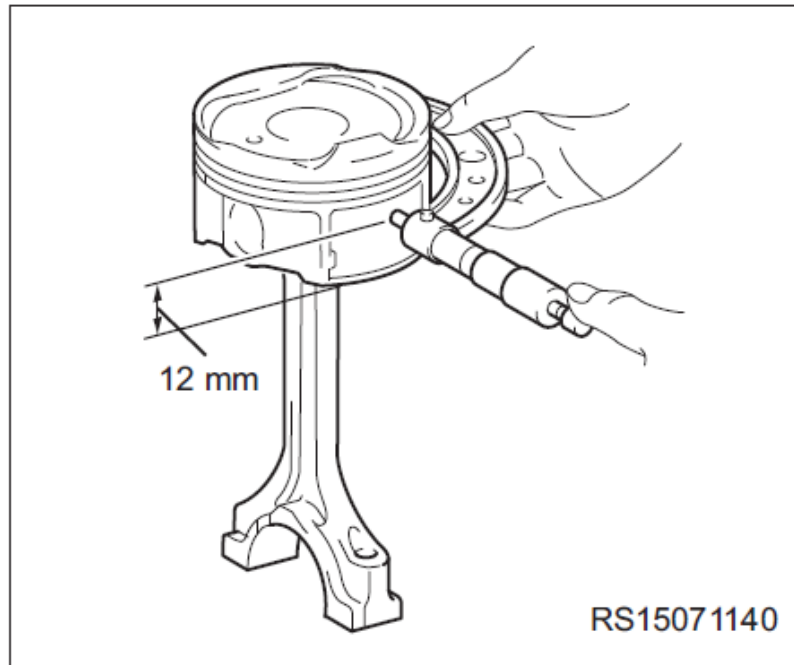

مقدار استاندارد را از جداول یافته و در این قسمت یادداشت نموده و با مقدار واقعی که اندازه گیری نموده اید مطابقت دهید.

اندازه گیری لقی رینگ در پیستون

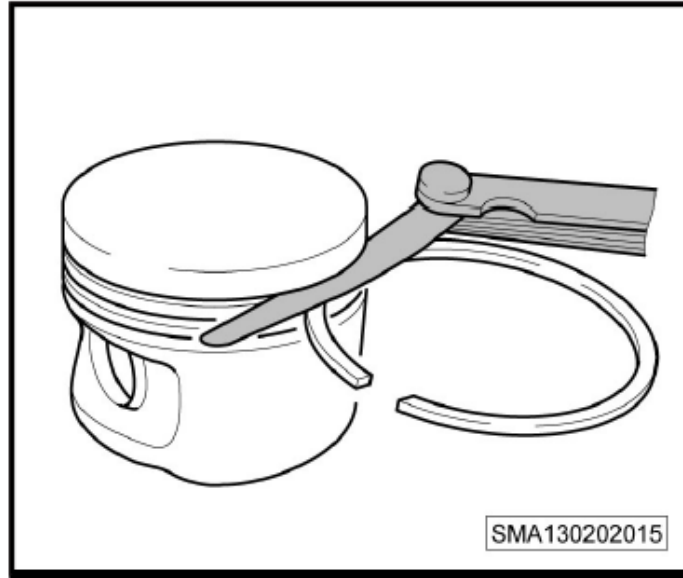

مقادیر مجاز:

Measurement Item		Specification (mm)
Piston Ring Side Clearance	First Ring	0.03 - 0.07
	Second Ring	0.02 - 0.06

اندازه گیری دهانه رینگ درون سیلندر

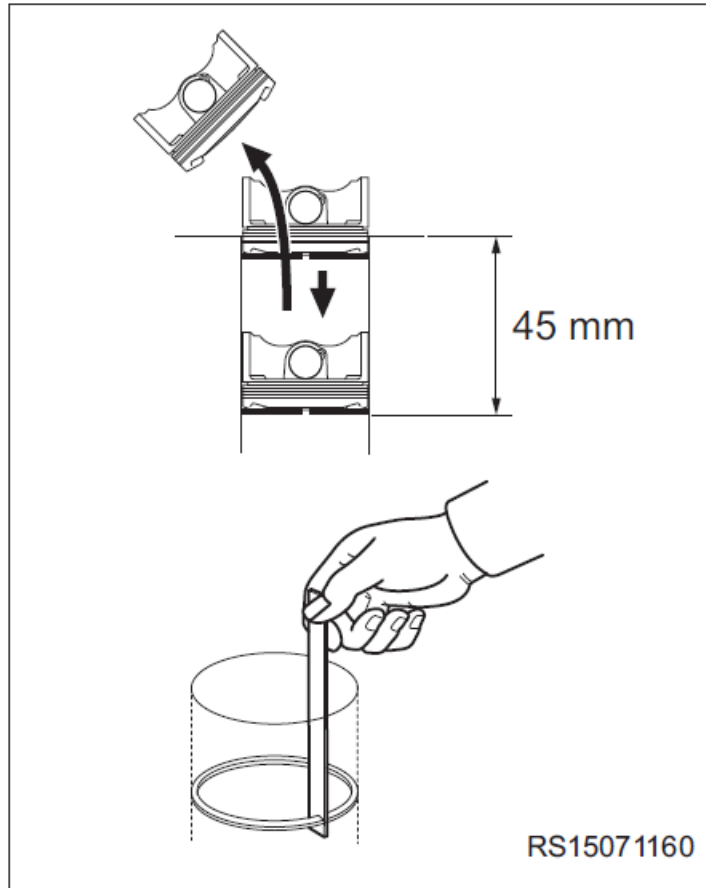

مقادیر مجاز:

Measurement Item		Specification (mm)
Piston Ring End Gap	First Ring	0.2 - 0.35
	Second Ring	0.4 - 0.55

شرایط اندازه گیری و نحوه انجام آن:

ابزار اندازه گیری تاب سیلندر:

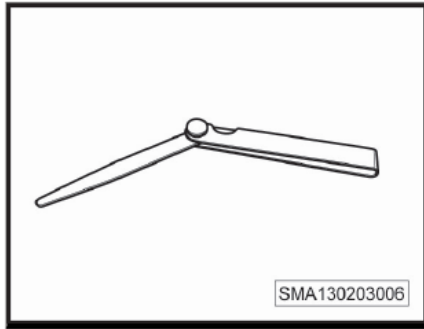

Clearance gauge

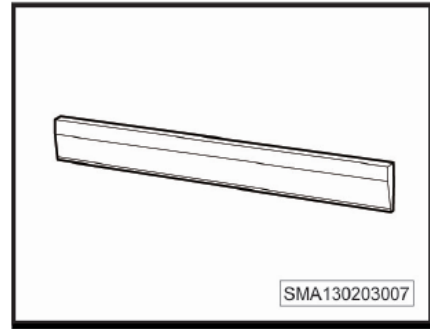

Precision ruler

نحوه اندازه گیری و مقادیر مجاز را بنویسید.

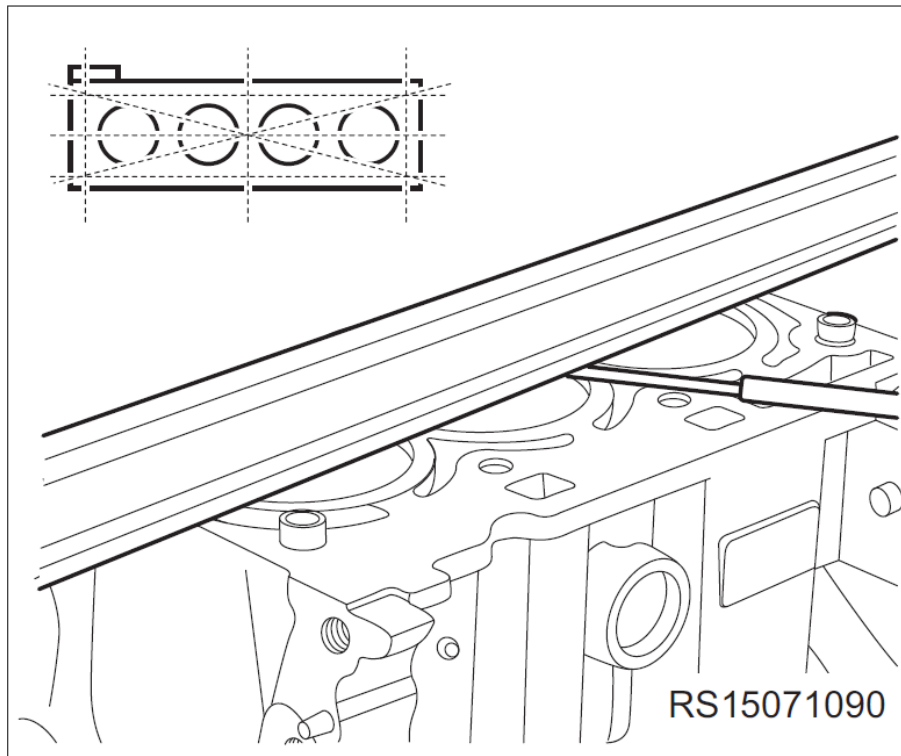

اندازه گیری قطر سیلندر

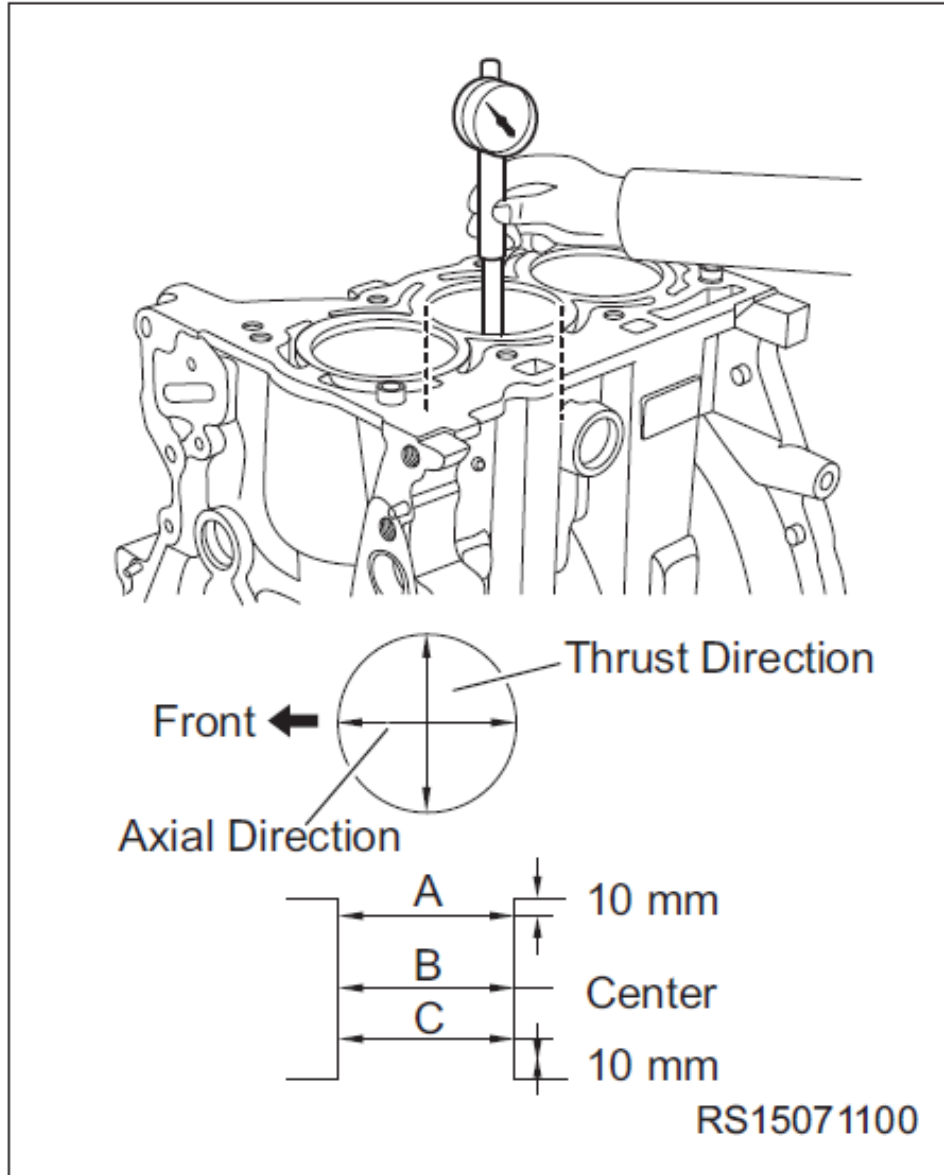

Measurement Item	Specification (mm)
Cylinder Bore	71.025
Cylindricity	0.008

$$\text{Cylindricity} = (\text{maximum diameter} - \text{minimum diameter})/2$$

مشخصات فنی سرسیلندر

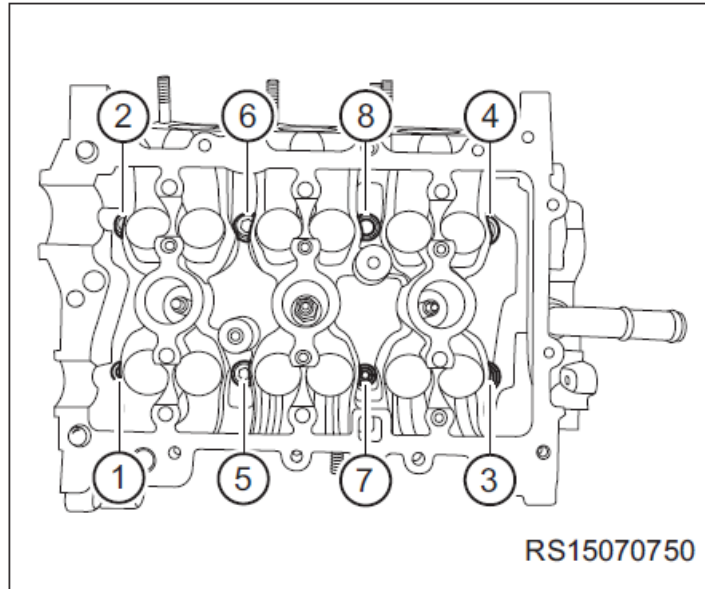

باز کردن پیچ های سرسیلندر

برای بستن از شماره ۸ شروع و با شماره ۱ خاتمه میابد.

گشتاور بستن پیچ های سرسیلندر:

- 1st step: tighten the bolt to 30 ± 2 N·m;
- 2nd step: rotate the bolt for 180° counterclockwise and tighten the bolt to 50 ± 2 N·m;
- 3rd step: rotate the bolt for $60^\circ \pm 5^\circ$ clockwise.

اندازه گیری لقی سوپاپ داخل گاید:

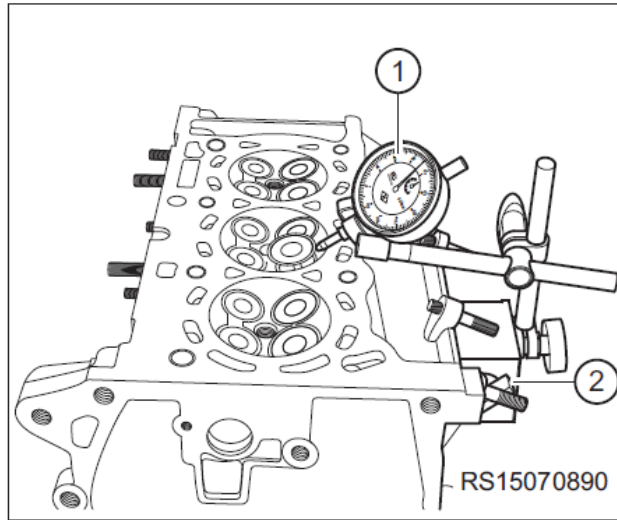

Measurement Item		Specification (mm)
Clearance Between Valve Lifter and Guide	Intake Valve	0.038 - 0.053
	Exhaust Valve	0.048 - 0.063

اندازه گیری طول فنر:

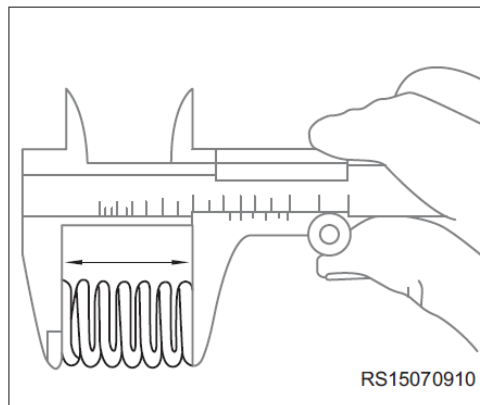

Measurement Item		Specification (mm)
Valve Spring	Free Height	49.4
	Height After Installation (mm)	33.7

کنترل تاب سرسیلندر:

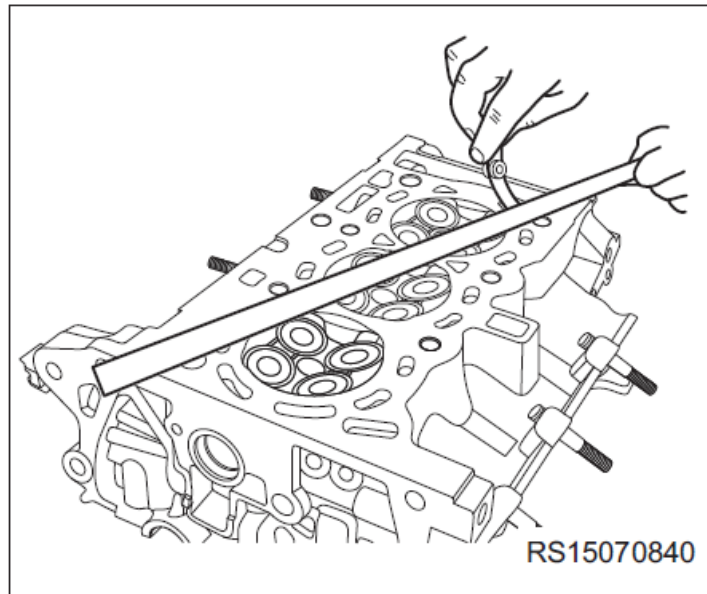

تاب مجاز سرسیلندر: 0.04 mm

رنگ بندی یاتاقان

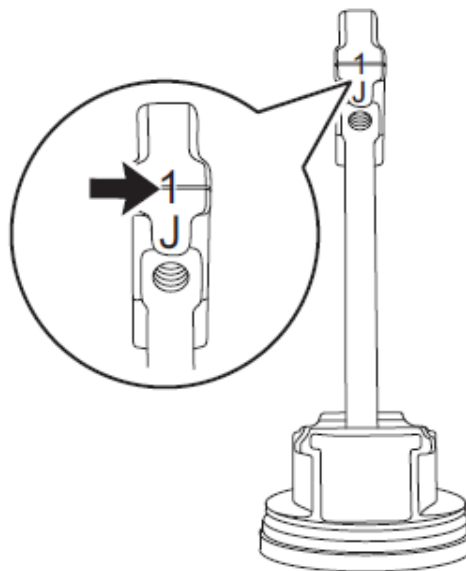

Name	Color	Mark on Connecting Rod Body
Connecting Rod Bearing Upper Shell	Red	1
	Blue	2

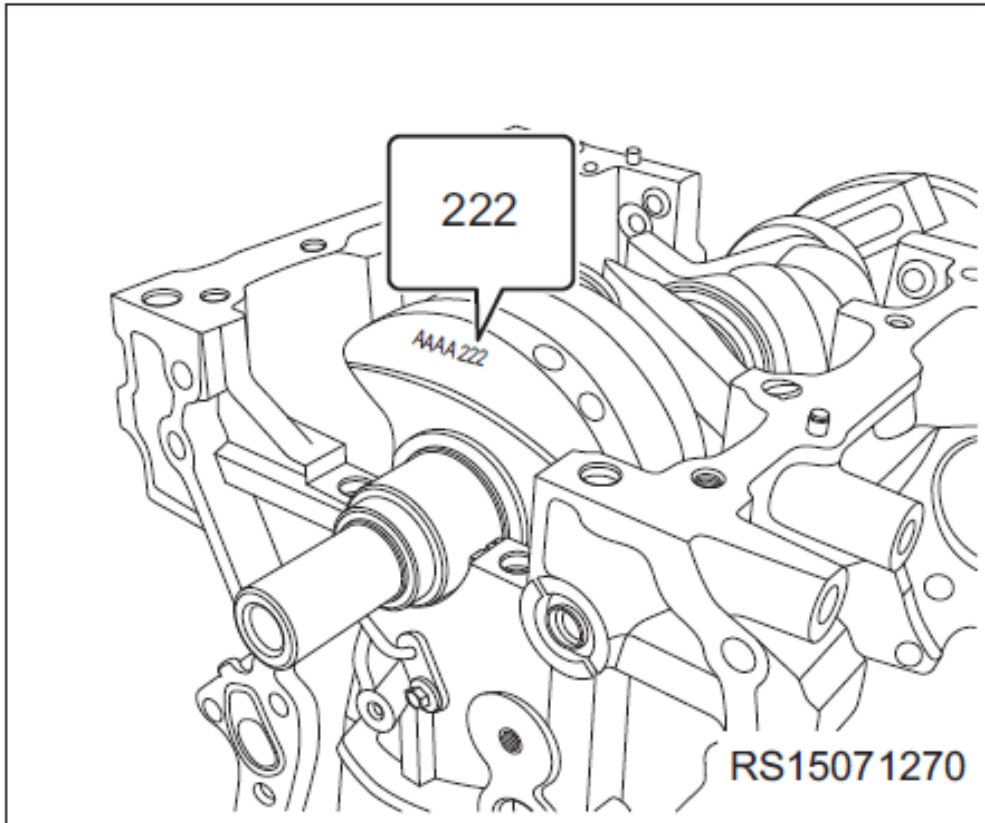

Name	Color	Mark on Crankshaft
Connecting Rod Bearing Lower Shell	Red	1
	Blue	2

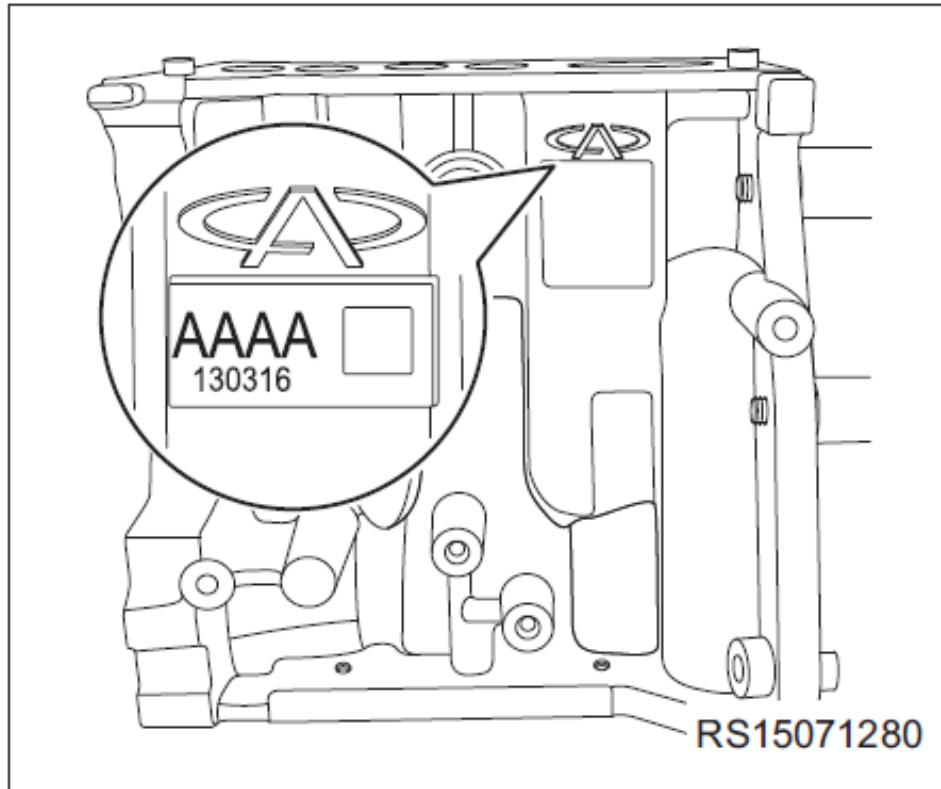

Name	Color	Mark on Engine Block
Main Bearing Upper Shell	Red	A
	Blue	B

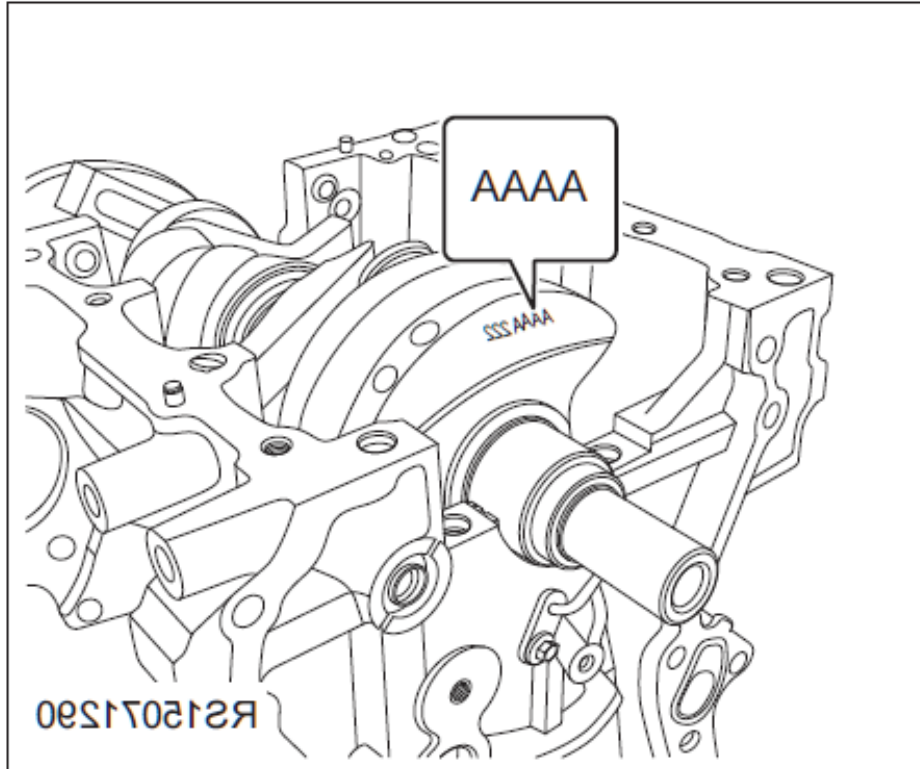

Name	Color	Mark on Crankshaft
Main Bearing Lower Shell	Red	A
	Blue	B

بستن پیچ های کپه ثابت میل لنگ

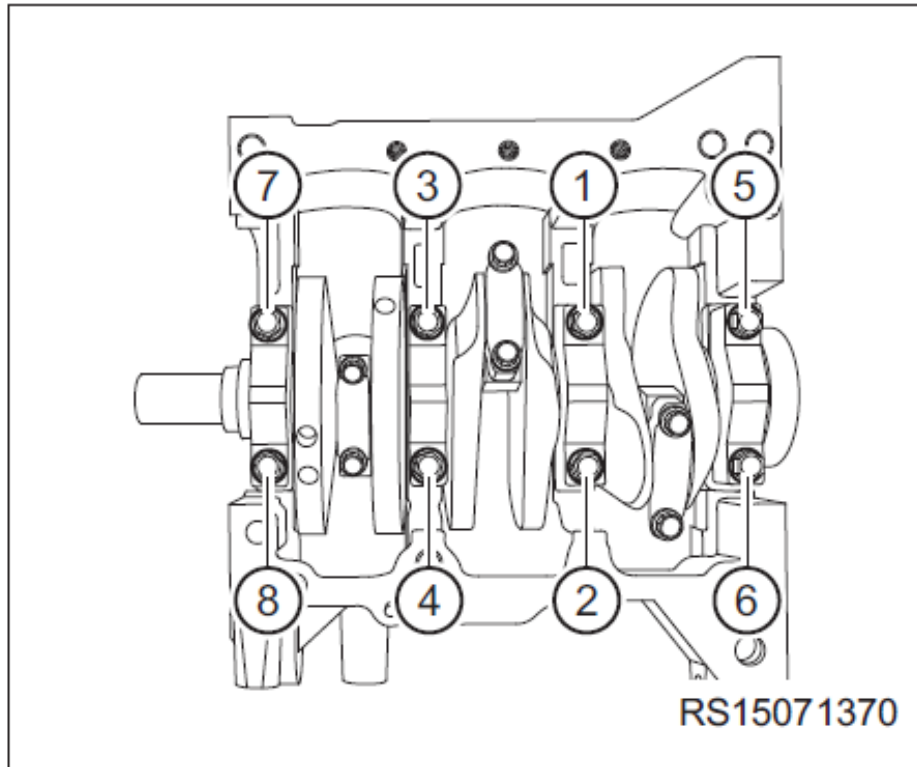

Tighten the main bearing cap bolts: firstly, tighten each bolt into place by hand, then tighten the main bearing cap bolts to 22 - 28 N·m as specified, and turn them for 55° - 65° finally.

ترموستات و تست آن

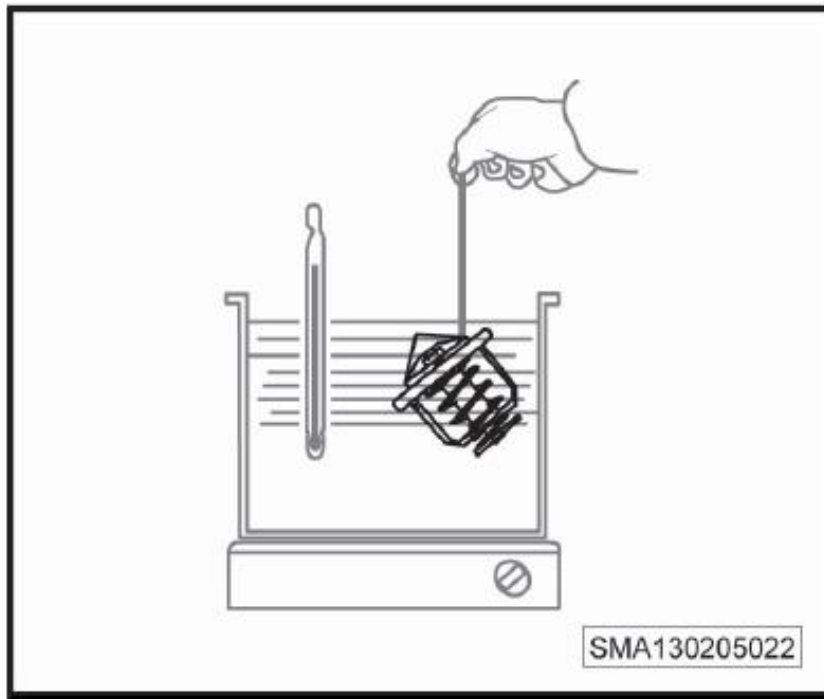
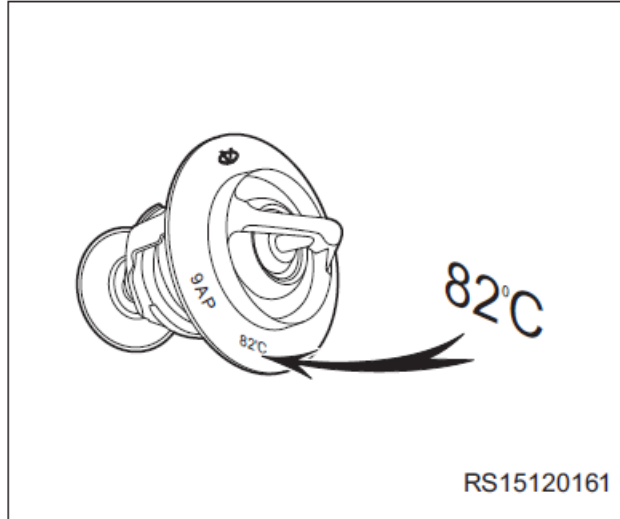

- The opening temperature of thermostat is 82°C.
 - The maximum lift of thermostat is no less than 8 mm.
 - The temperature is 95°C when the thermostat is fully opened.
- Check that the thermostat closes when the temperature is low (5°C lower than the opening temperature).

شماتیک مدار خنک کاری

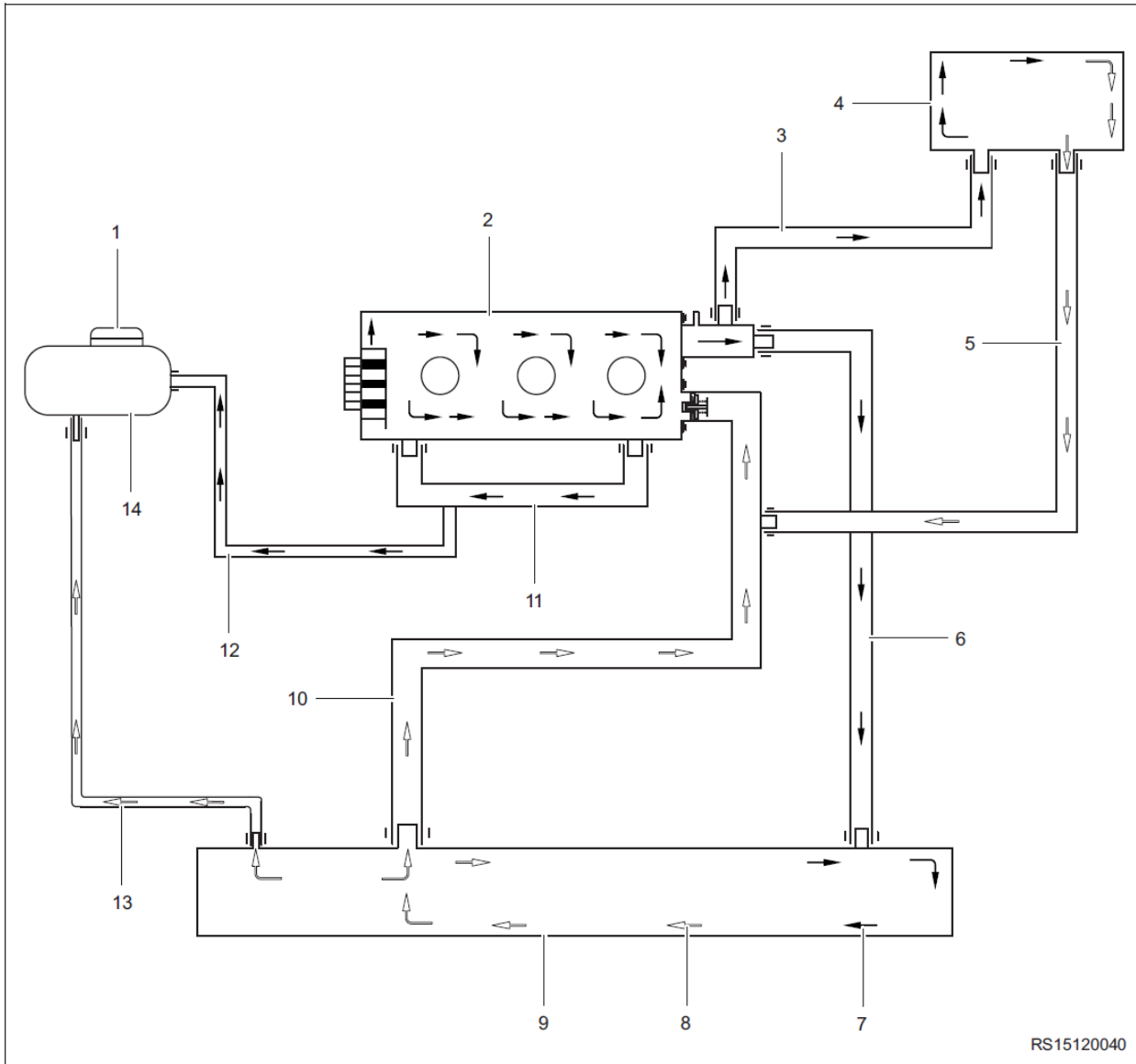

RS15120040

1 - Expansion Tank Cover	2 - Cylinder Block
3 - Heating Inlet Pipe	4 - Heater Core
5 - Heating Outlet Pipe	6 - Engine Outlet Pipe
7 - Black Solid Arrow (Indicates High Temperature Coolant)	8 - Hollow Arrow (Indicates Low Temperature Coolant)
9 - Radiator	10 - Engine Inlet Pipe
11 - Small Circulation Metal Tube	12 - Engine Return Pipe
13 - Radiator Degassing Hose	14 - Expansion Tank

شماتیک مدار روغن کاری

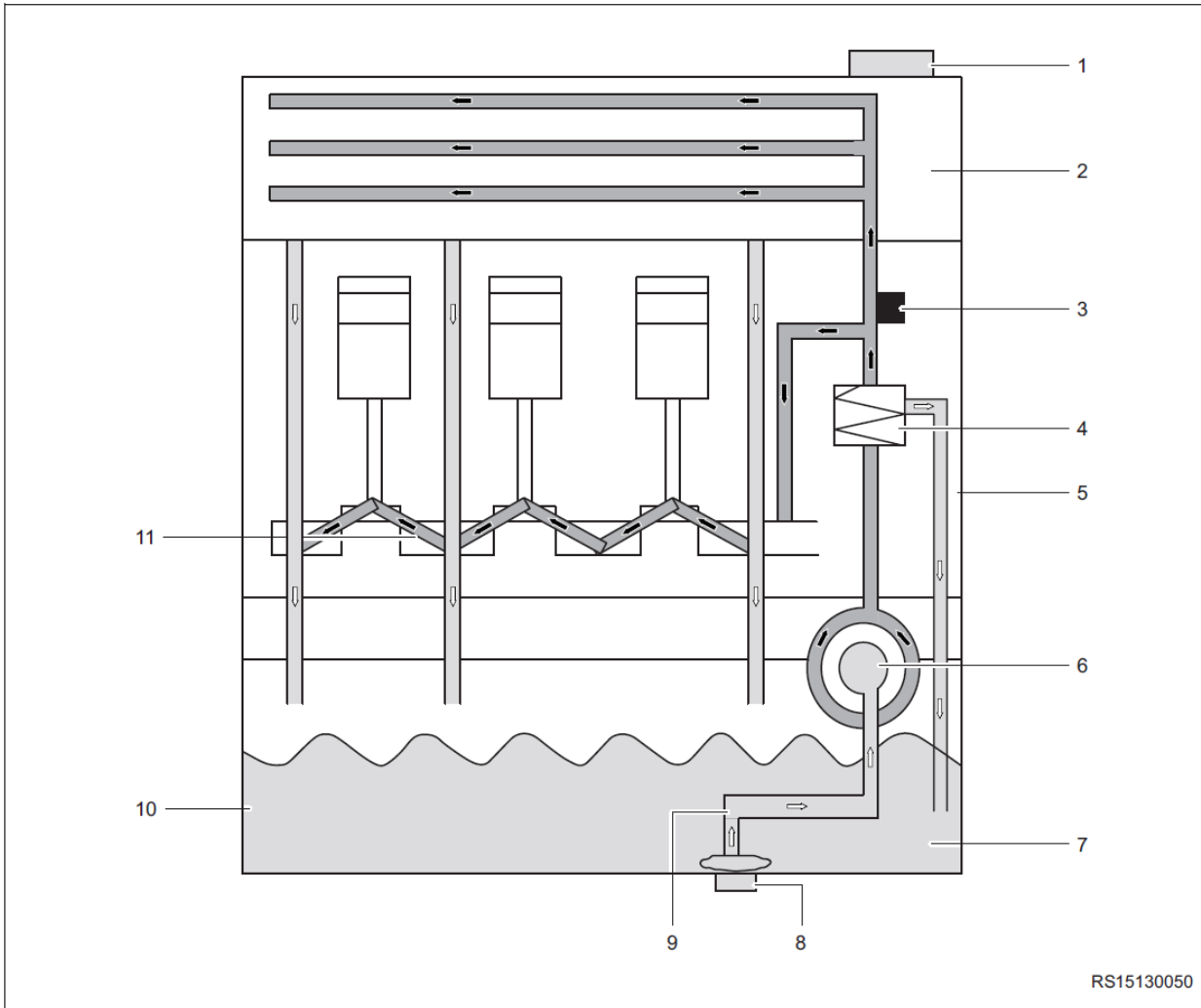

RS15130050

1 - Engine Oil Filler Cap	2 - Cylinder Head
3 - Oil Pressure Switch	4 - Oil Filter
5 - Cylinder Block	6 - Oil Pump
7 - Engine Oil	8 - Drain Plug
9 - Oil Strainer	10 - Oil Pan
11 - Crankshaft	

Description

1. Solid arrow: indicates the flow of high-pressure lubricant.
2. Hollow arrow: indicates the flow of low-pressure lubricant.
3. Dark area: indicates the high-pressure lubricant.
4. Bright area: indicates the low-pressure lubricant.

تست فشار روغن

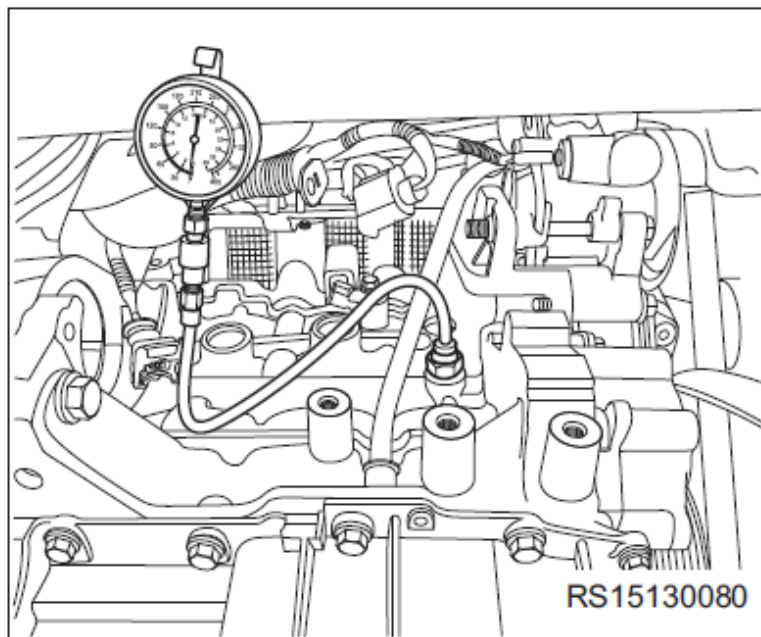
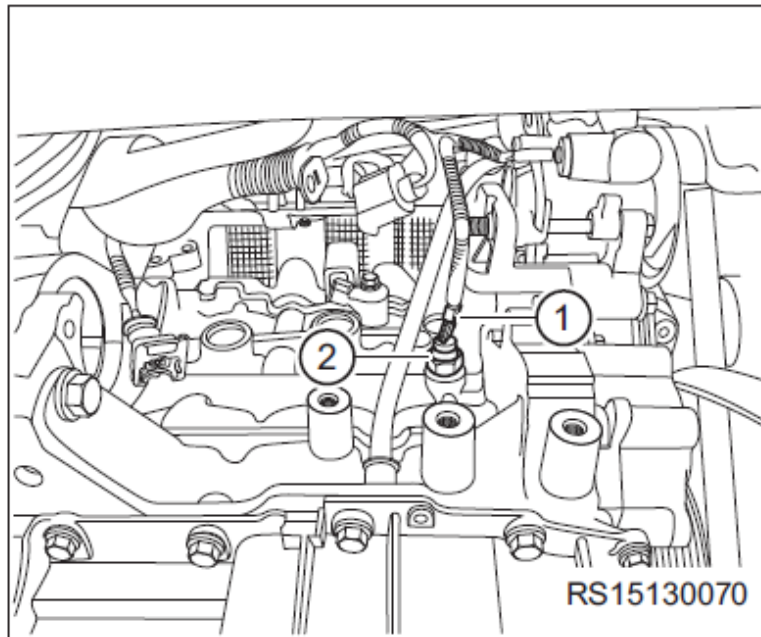

Oil pressure at low idling speed (800 ± 50 r/min): 120 - 150 kPa
Oil pressure at high idling speed (2000 ± 50 r/min): 320 - 350 kPa
Oil pressure at high speed (4000 r/min): 370 ± 50 kPa

بخش دوم

گیربکس

مشخصات فنی

Transmission Gear Ratio Table

Type	QR512MHG
1st	3.818
2nd	2.412
3rd	1.308
4th	1.029
5th	0.838
Reverse	3.583
Final Drive Ratio	3.550

Clearance Specifications

Description	Standard Value (mm)	Limit Value (mm)
Clearance Between 1st Driven Gear and Synchronizer Ring	1.15 - 1.65	1.15 - 1.65
Clearance Between 2nd Driven Gear and Synchronizer Ring	1.15 - 1.65	1.15 - 1.65
Clearance Between 2nd Driven Gear and 3rd Driven Gear	0.22 - 0.30	0.22 - 0.30
Clearance Between 3rd Drive Gear and Synchronizer Ring	0.8 - 1.4	0.8 - 1.4
Clearance Between 4th Drive Gear and Synchronizer Ring	0.8 - 1.4	0.8 - 1.4
Clearance Between 2nd Drive Gear and 3rd Drive Gear	0.13 - 0.44	0.13 - 0.44
Clearance Between 4th Drive Gear and Input Shaft Rear Bearing	0.15 - 0.35	0.15 - 0.35

مشخصات روغن گیربکس

Model	S15
Transmission Fluid Type	SAE 75W-90 GL-4
Filling Capacity	2.1 L

بخش های اصلی سیستم انتقال قدرت

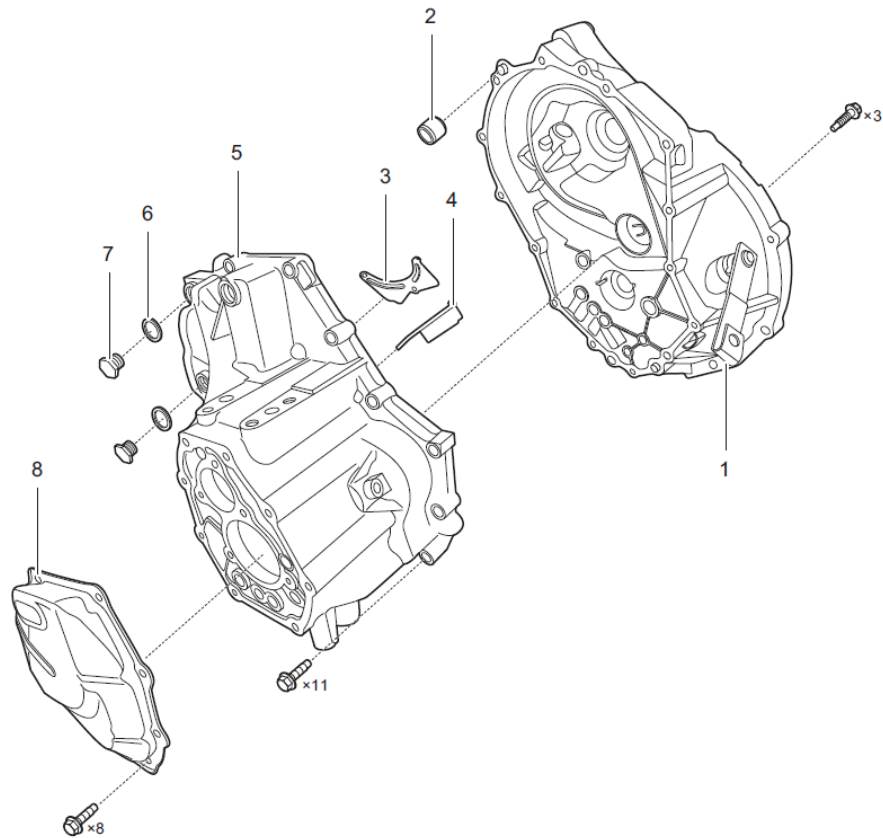

RS1517001C

1 - Clutch Case	2 - Dowel Pin
3 - Oil Deflector	4 - Oil Guide
5 - Transmission Case	6 - Washer
7 - Drain Plug	8 - Rear Case Cover

شفت ورودی

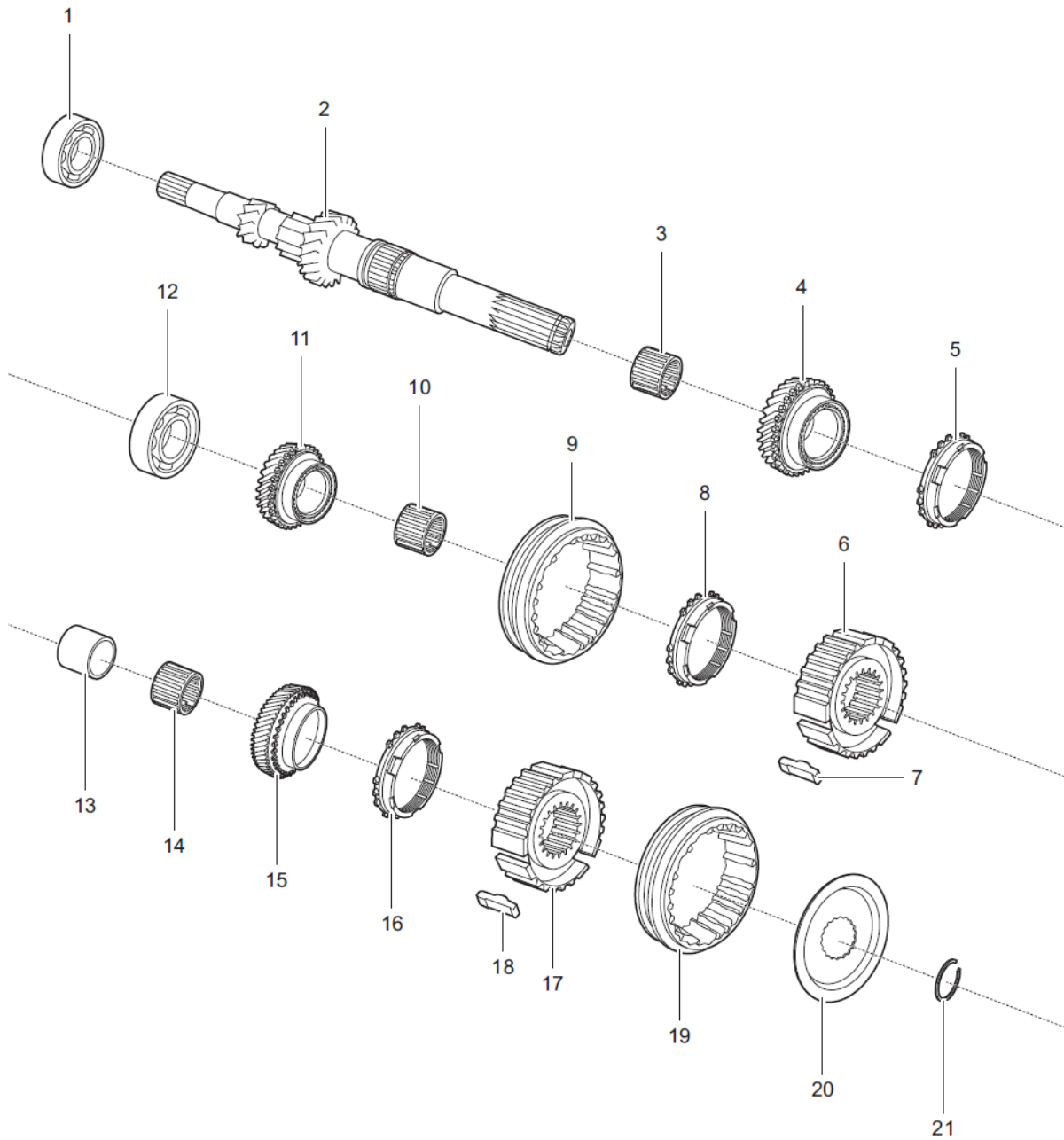

1 - Input Shaft Front Bearing	2 - Input Shaft
3 - 3rd Needle Roller Bearing	4 - 3rd Drive Gear
5 - 3rd Synchronizer Ring	6 - 3rd-4th Synchronizer Gear Hub
7 - Synchronizer Key	8 - 4th Synchronizer Ring
9 - Synchronizer Gear Sleeve	10 - 4th Needle Roller Bearing
11 - 4th Drive Gear	12 - Input Shaft Rear Bearing
13 - 5th Needle Roller Bearing Bushing	14 - 5th Needle Roller Bearing
15 - 5th Drive Gear	16 - 5th Synchronizer Ring
17 - 5th Synchronizer Gear Hub	18 - Synchronizer Key
19 - Synchronizer Gear Sleeve	20 - Baffle Plate
21 - Snap Ring	

شفت خروجی

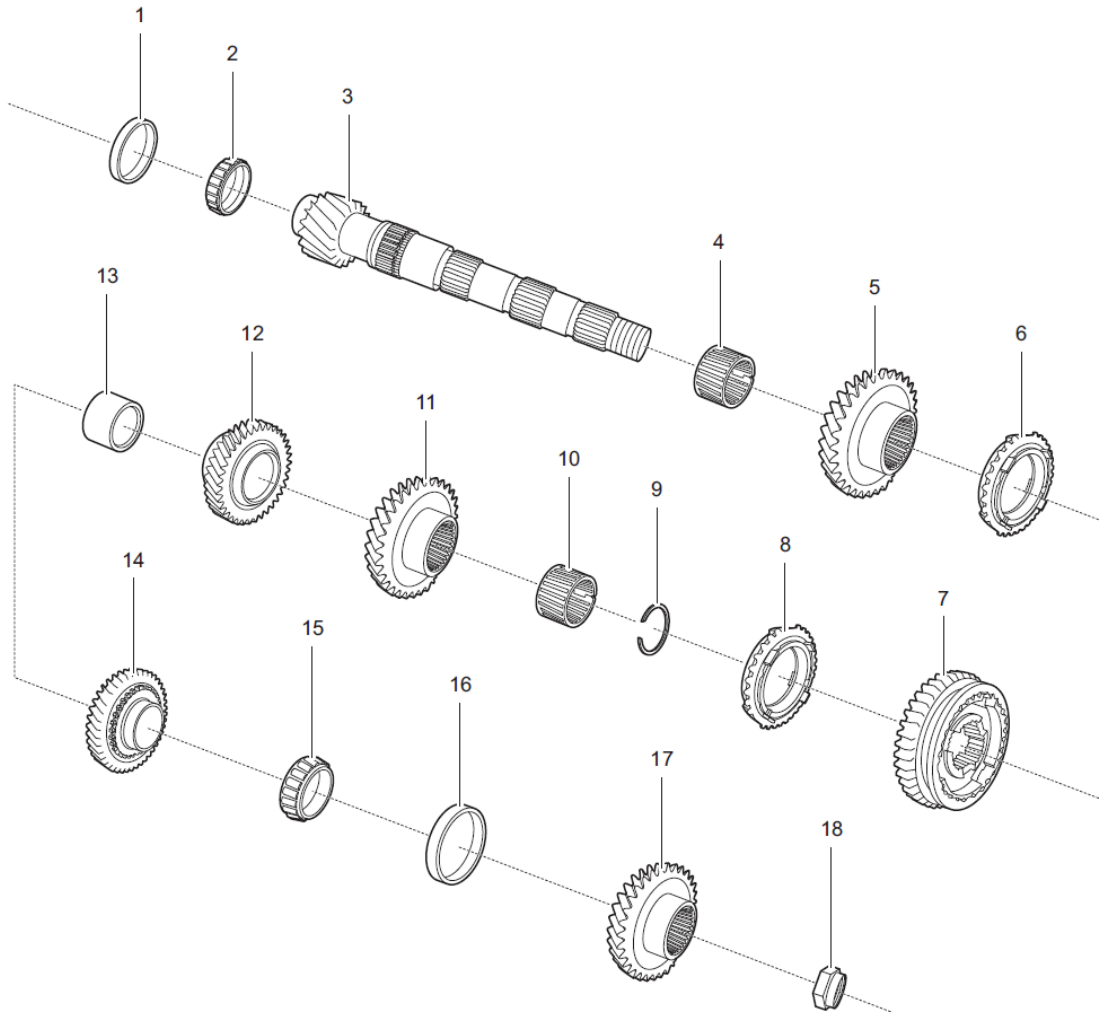

1 - Output Shaft Front Bearing Outer Race	2 - Output Shaft Front Bearing
3 - Output Shaft	4 - 1st Needle Roller Bearing
5 - 1st Driven Gear	6 - 1st Synchronizer Ring Set
7 - 1st-2nd Synchronizer	8 - 2nd Synchronizer Ring Set
9 - Snap Ring	10 - 2nd Needle Roller Bearing
11 - 2nd Driven Gear	12 - 3rd Driven Gear
13 - Gear Shaft Bushing	14 - 4th Driven Gear
15 - Output Shaft Rear Bearing	16 - Output Shaft Rear Bearing Outer Race
17 - 5th Driven Gear	18 - 5th Driven Gear Locking Nut

اهرم بندی مکانیزم دنده ها

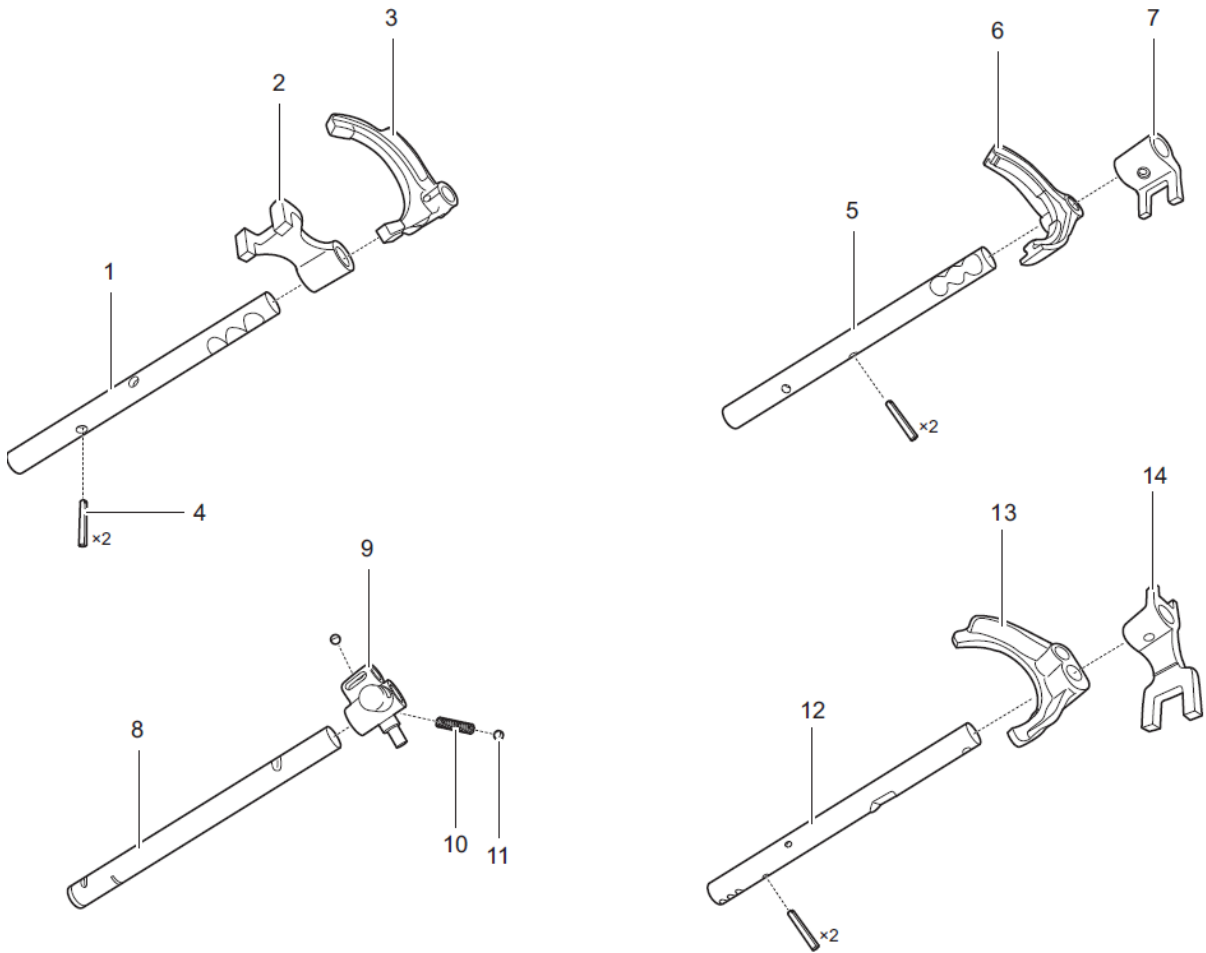

1 - 1st-2nd Gear Fork Shaft	2 - 1st-2nd Gear Fork Support
3 - 1st-2nd Gear Fork	4 - Dowel Pin
5 - 3rd -4th Gear Fork Shaft	6 - 3rd-4th Gear Fork
7 - 3rd-4th Gear Fork Support	8 - Reverse Gear Fork Shaft
9 - Reverse Gear Fork Dowel Pin	10 - Spring
11 - Ball	12 - 5th Gear Fork Shaft
13 - 5th Gear Fork	14 - 5th Gear Fork Support

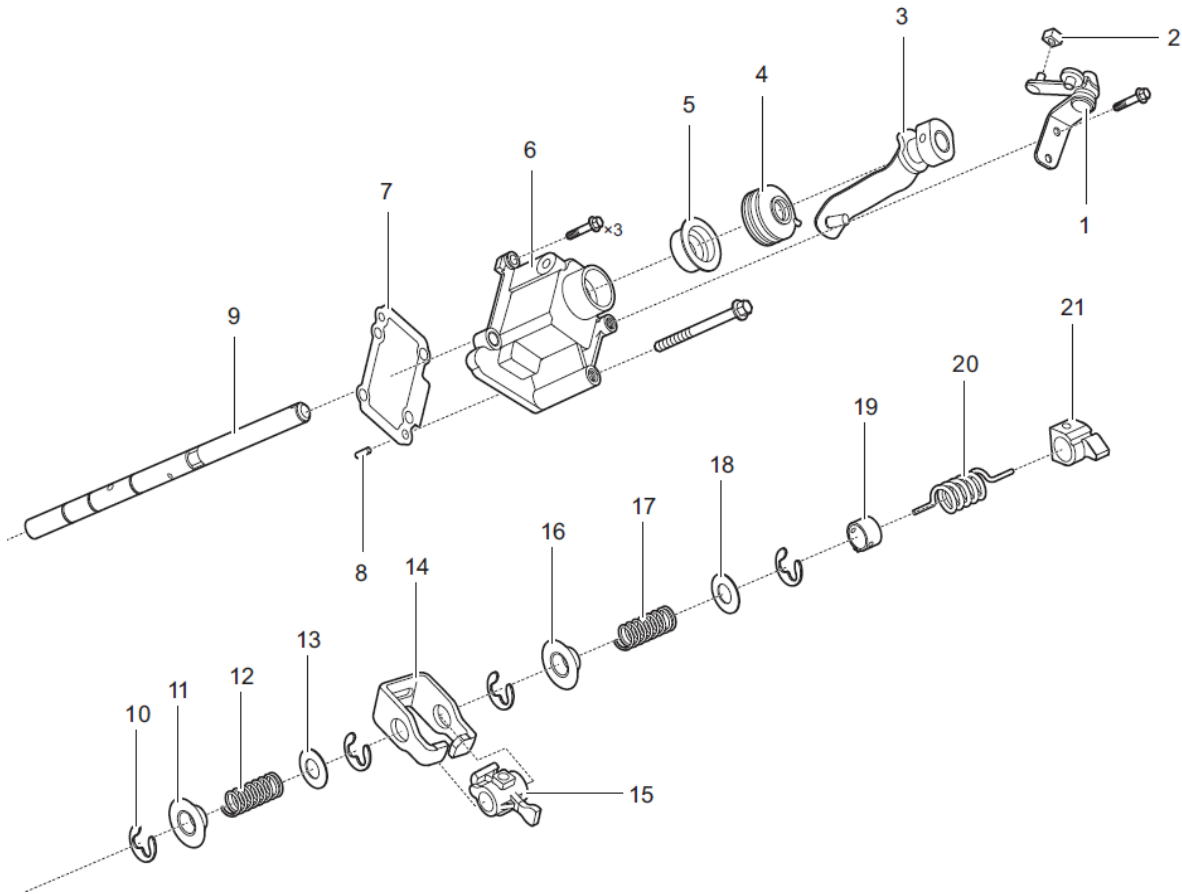

1 - Selector Arm	2 - Selector Arm Toggle Shifting Block
3 - Shifter Arm	4 - Dust Boot
5 - Shifter Case Oil Seal	6 - Shifter Case Body
7 - 5th and Reverse Gear Return Spring Seat Baffle Plate	8 - Dowel Pin
9 - Gear Select and Shift Shaft	10 - Cotter Pin
11 - 1st/2nd Gear Return Spring Seat	12 - 1st/2nd Gear Return Spring
13 - 1st/2nd Gear Return Spring Baffle Plate	14 - Interlock Plate
15 - Shift Finger	16 - 5th Gear Return Spring Washer
17 - 5th Gear Return Spring	18 - 5th Gear Return Spring Seat
19 - Reverse Gear Torsion Spring Lock Piece	20 - Reverse Gear Lock block Torsion Spring
21 - Reverse Gear Lock block	

ابزار مخصوص گیربکس

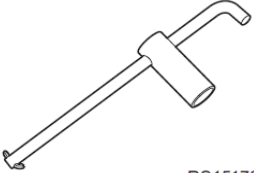
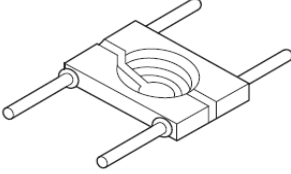
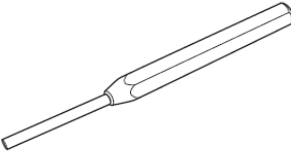
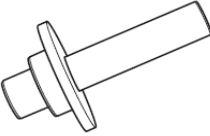
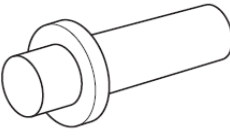
Input Shaft Holding Tool	 <p>RS15170060</p>
Bearing Remover	 <p>RS15200020</p>
Punch	 <p>RS15200030</p>
Differential Oil Seal Installer	 <p>RS15000090</p>
Input Shaft Front Oil Seal Installer	 <p>RS15000091</p>

جهت بررسی ابزار مخصوص ها به لیست SPECIAL TOOLS مراجعه کنید.

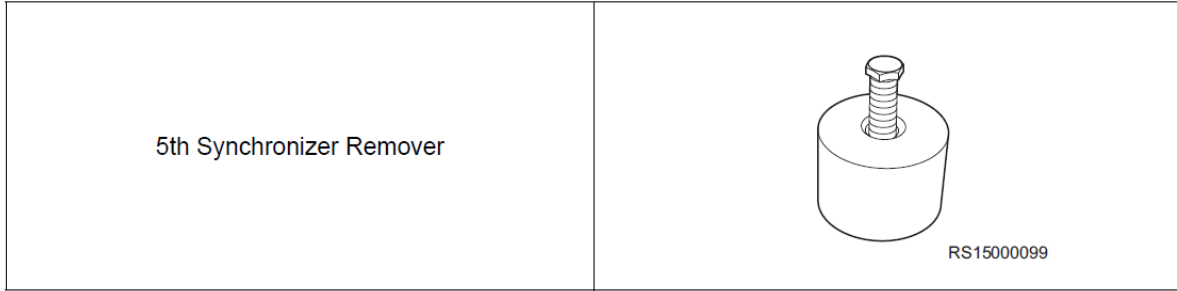

مجرای تخلیه و شارژ روغن گیربکس

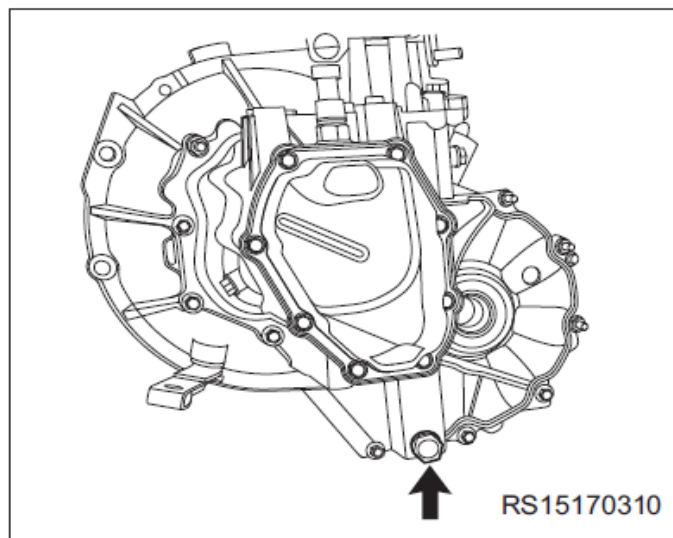
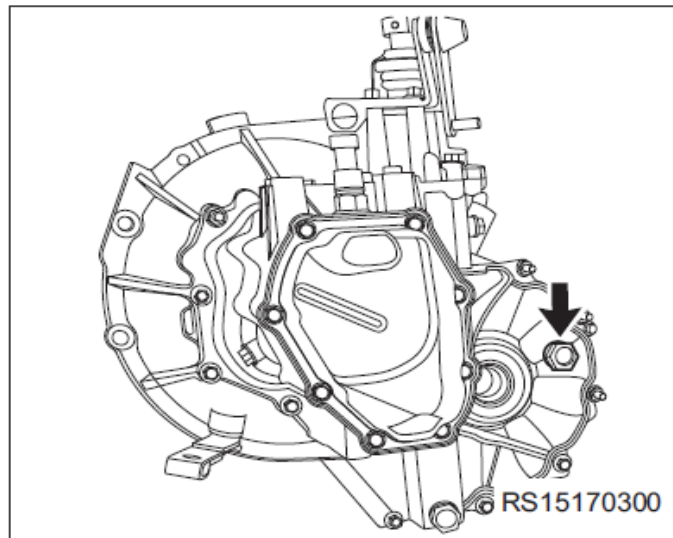

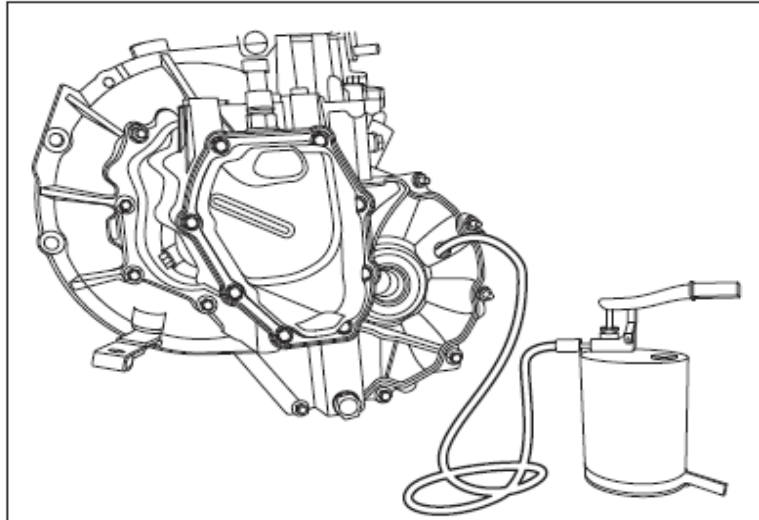

تعویض کاسه نمد گیربکس

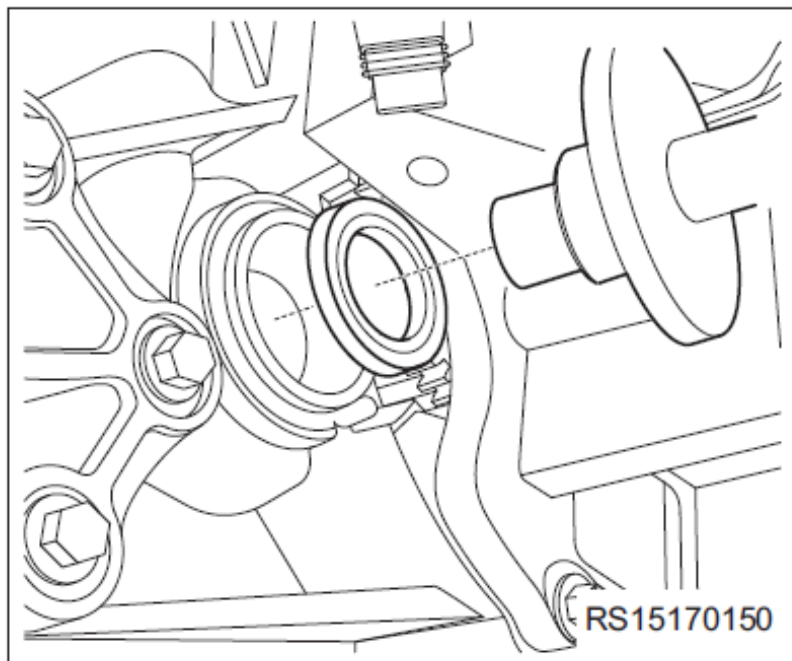
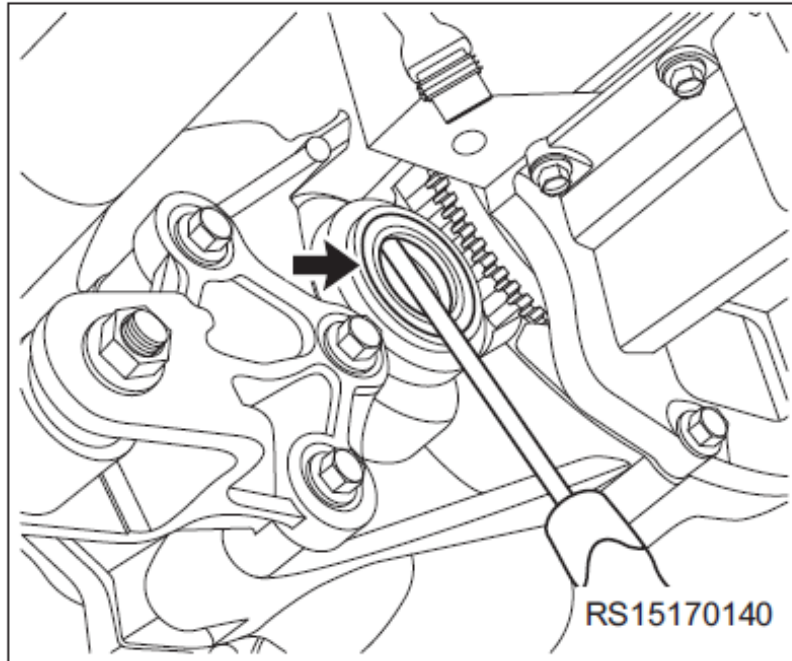

گشتاور مهره سرپلوس: 260 N.m

نحوه دمونتاژ اجزای گیربکس

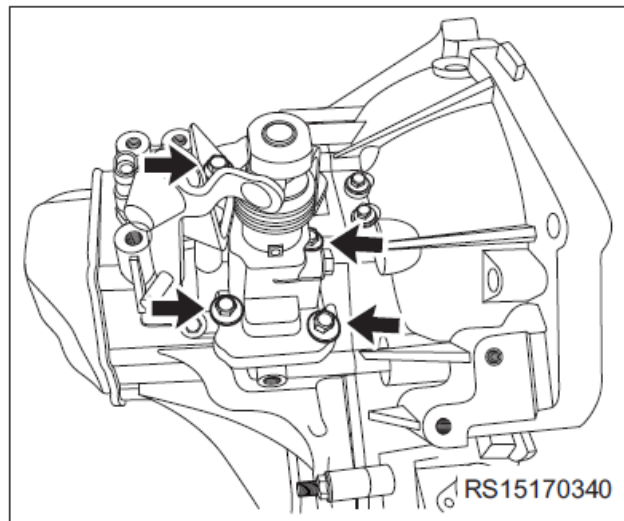
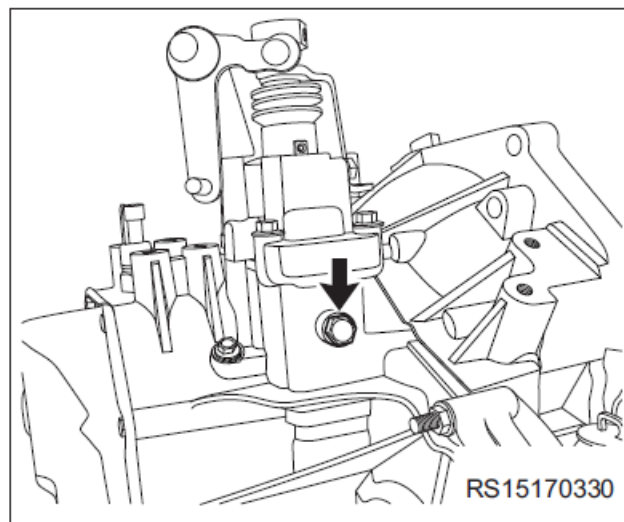
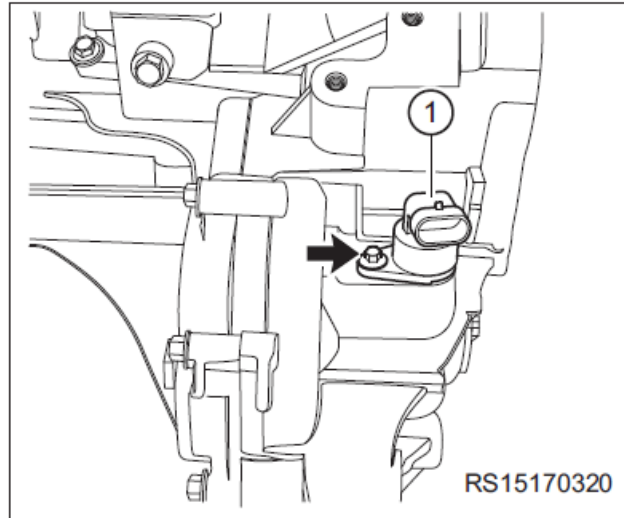

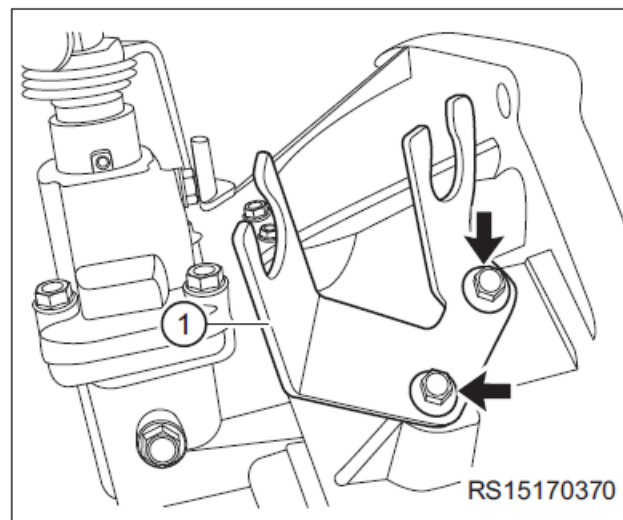
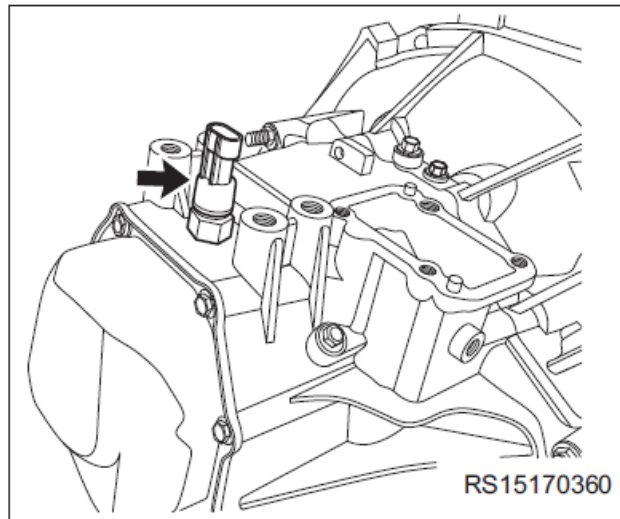
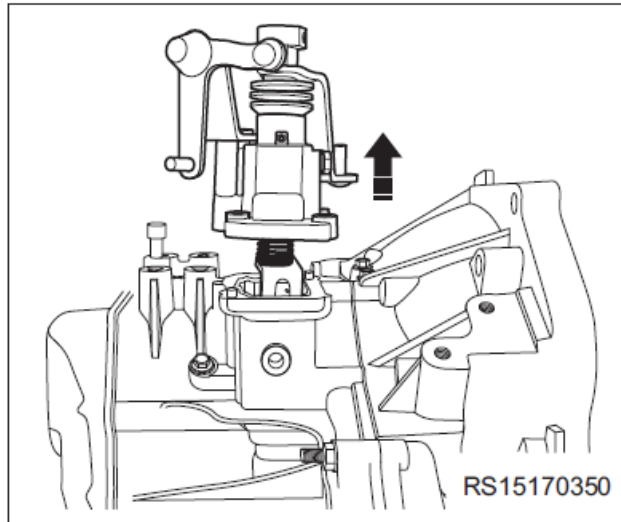

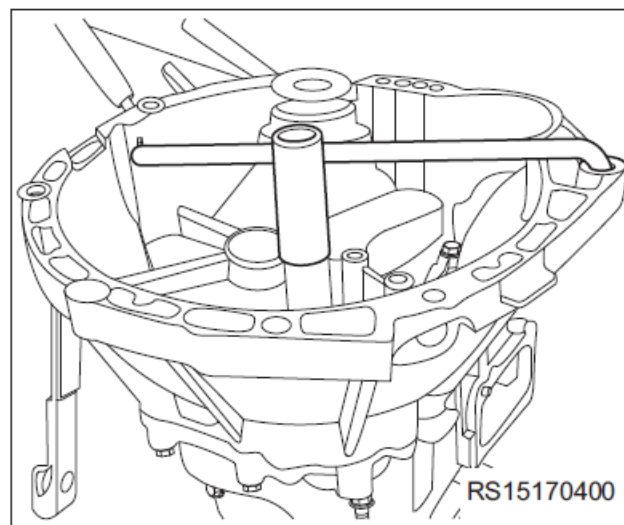
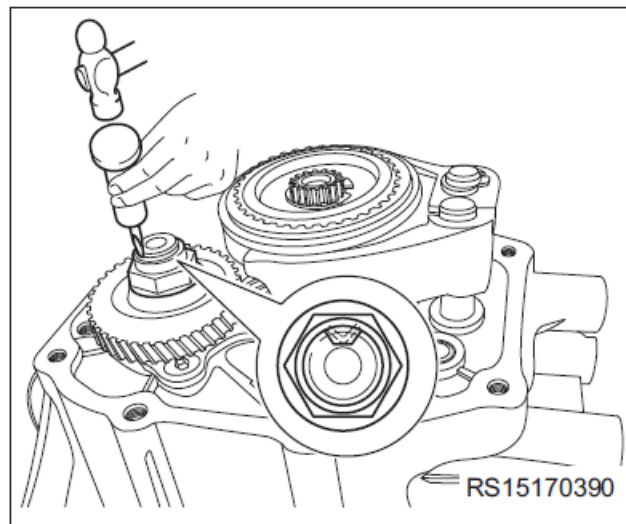
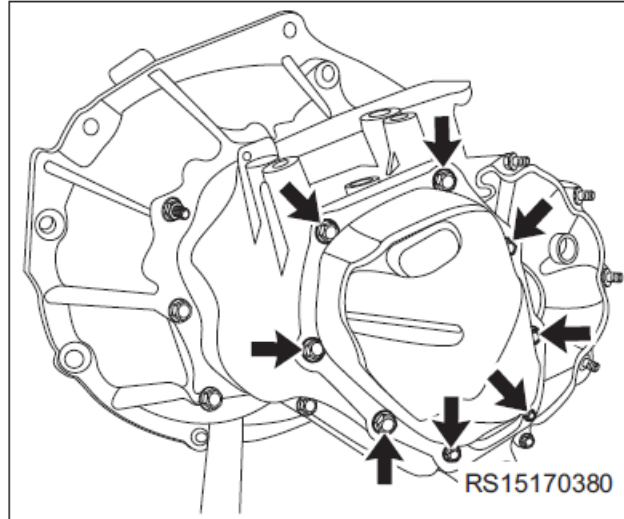

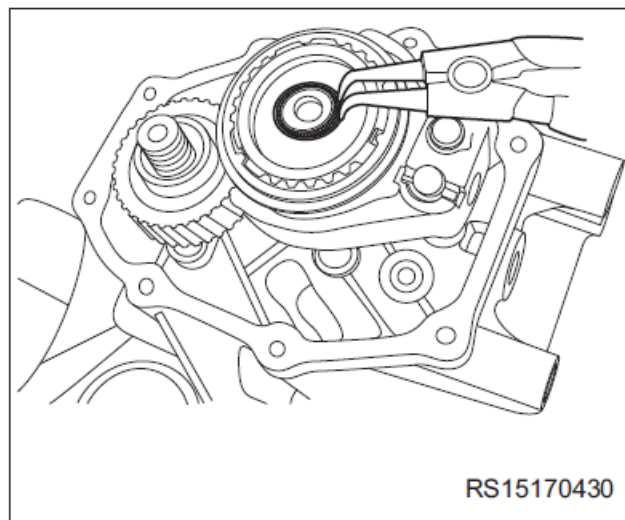
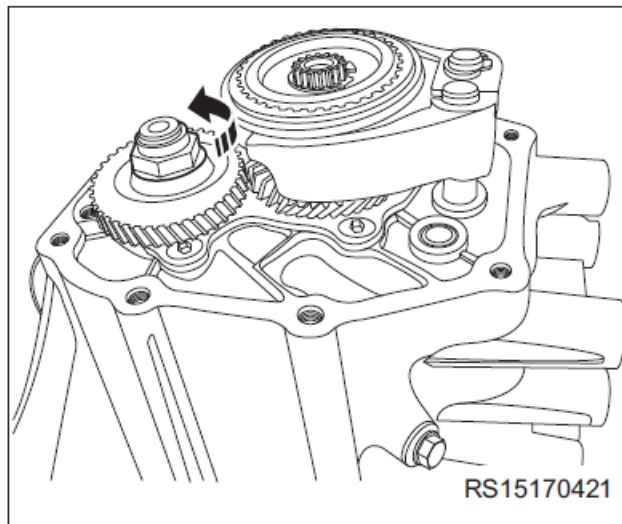
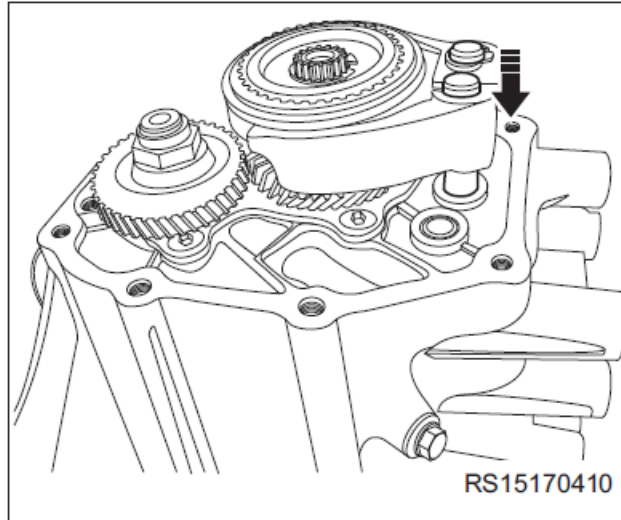

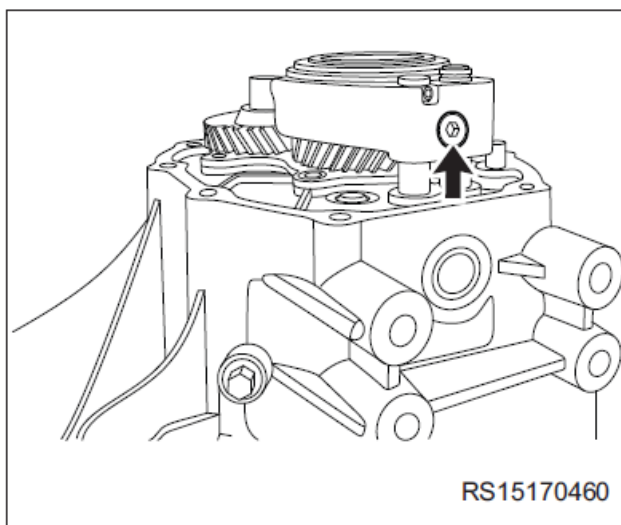
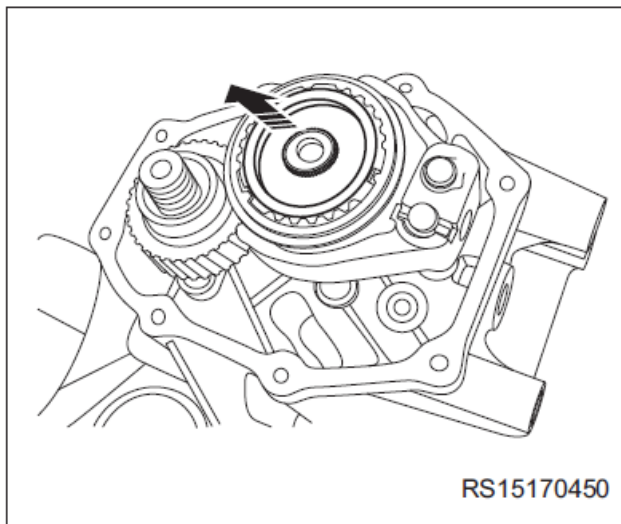
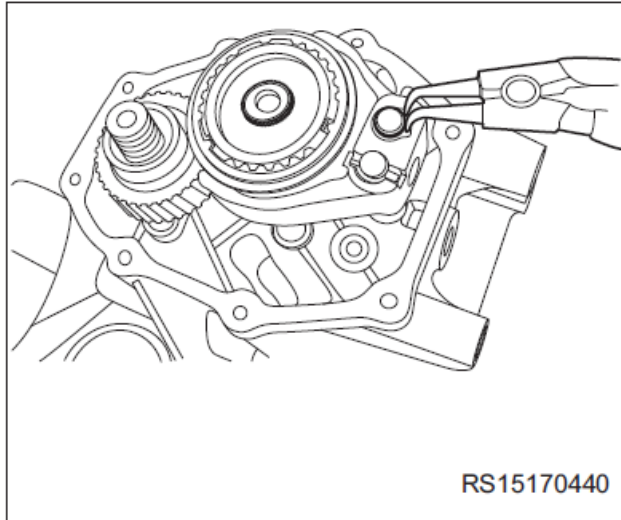

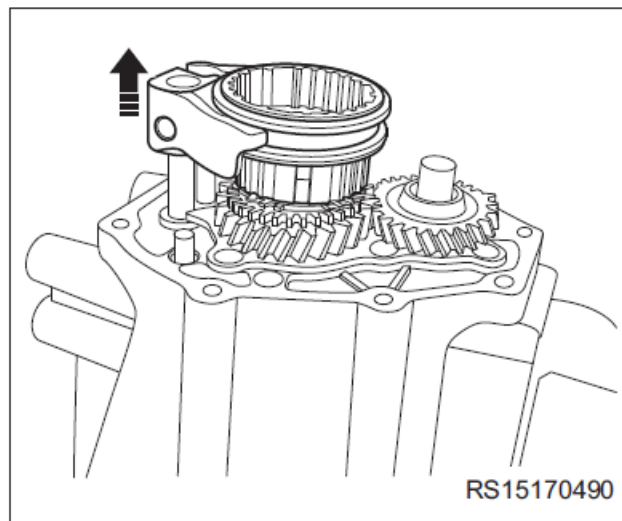
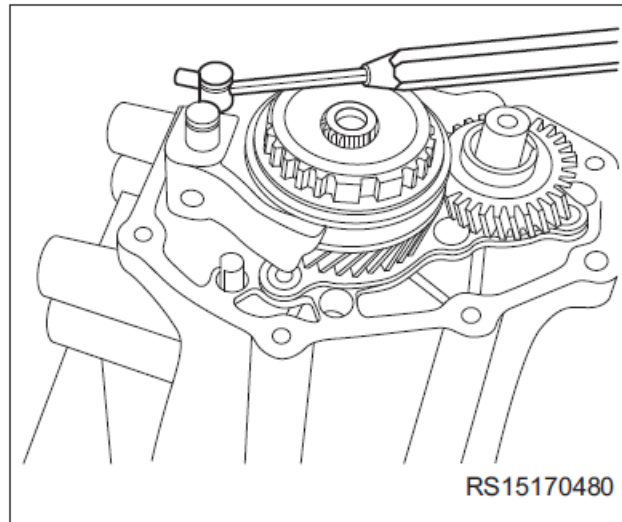
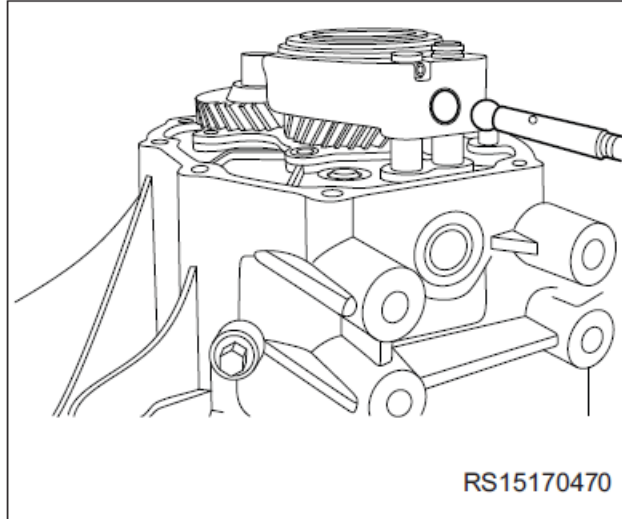

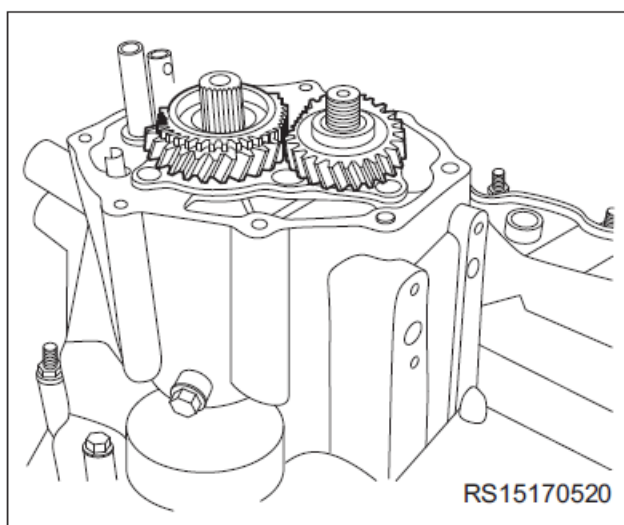
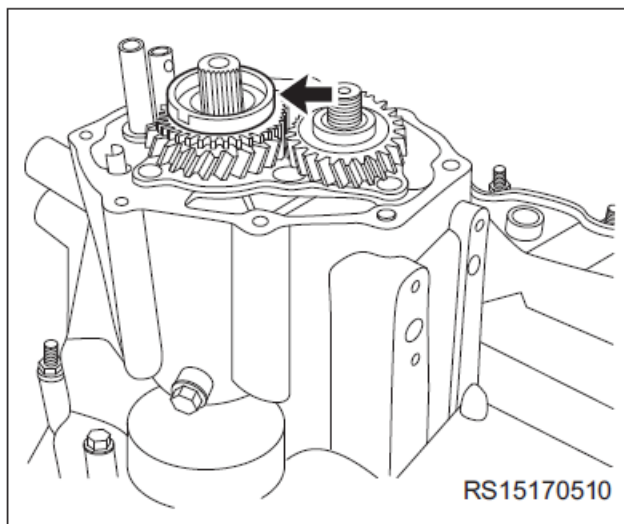
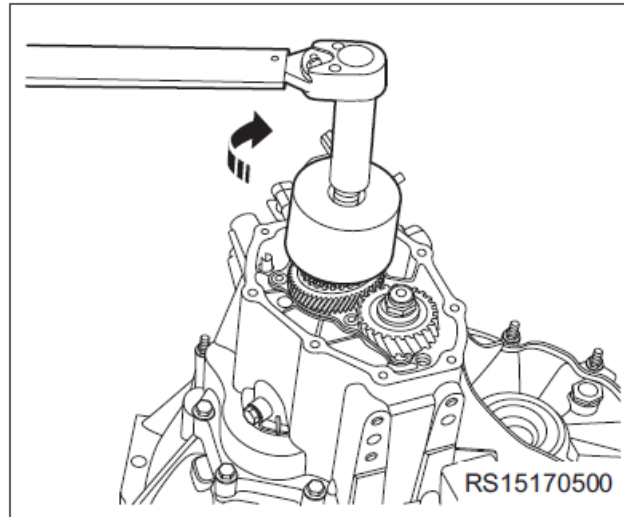

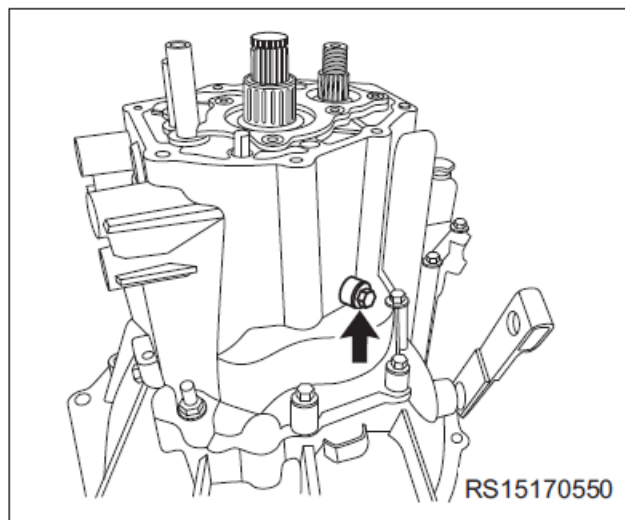
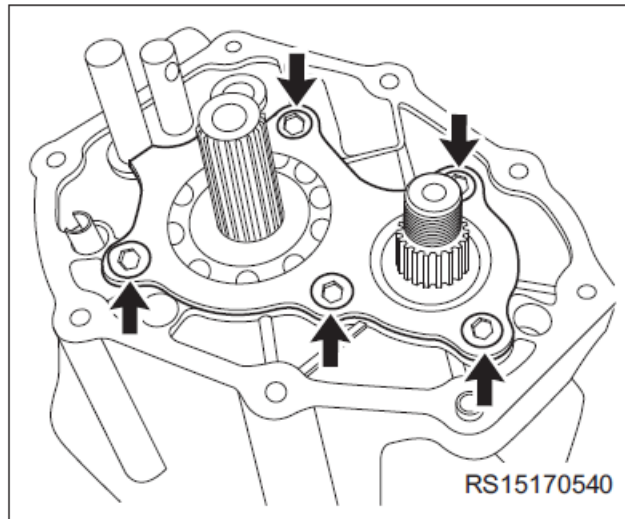
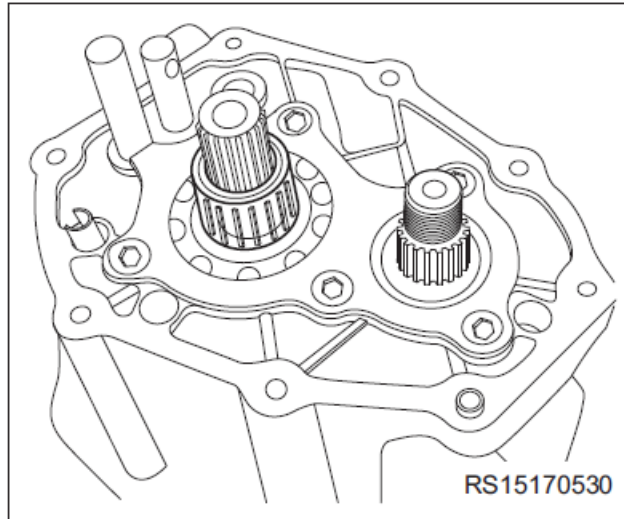

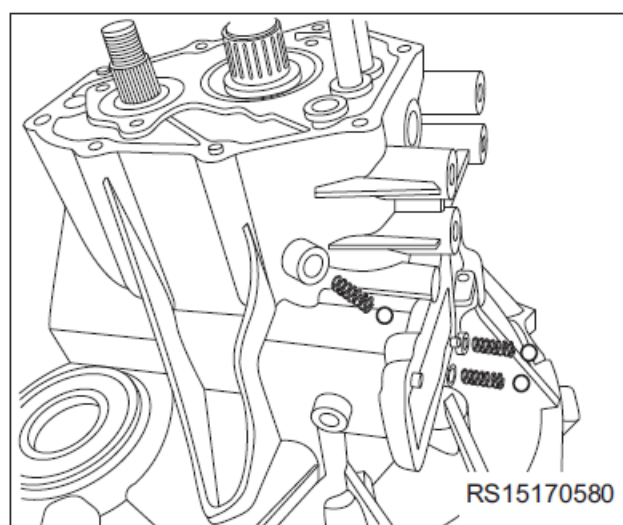
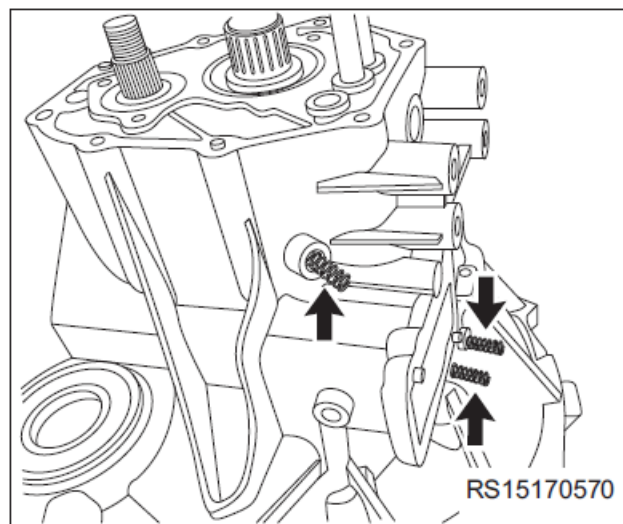
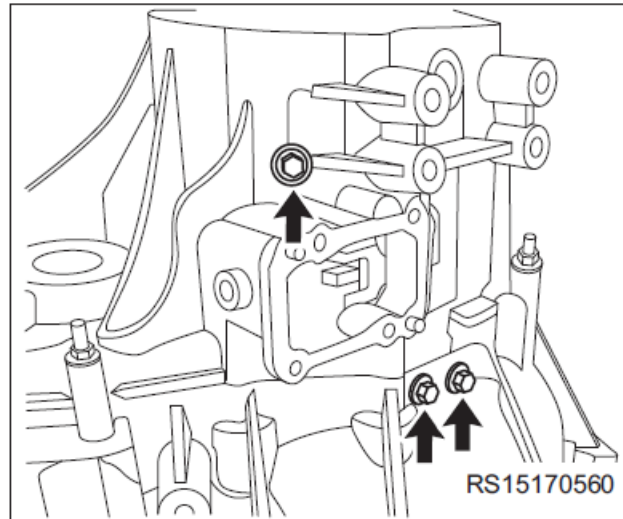

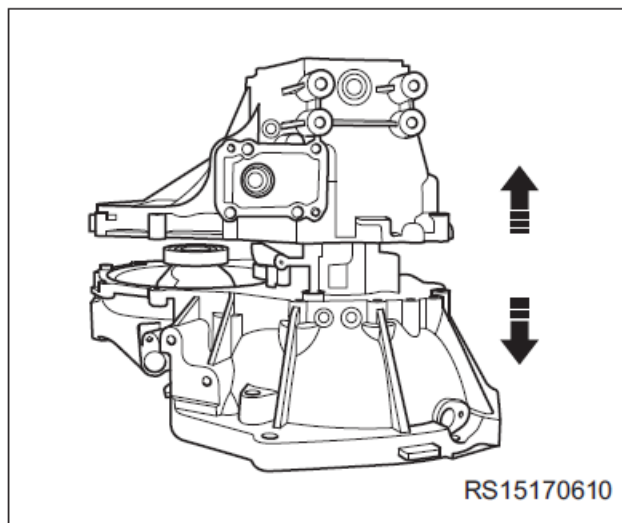
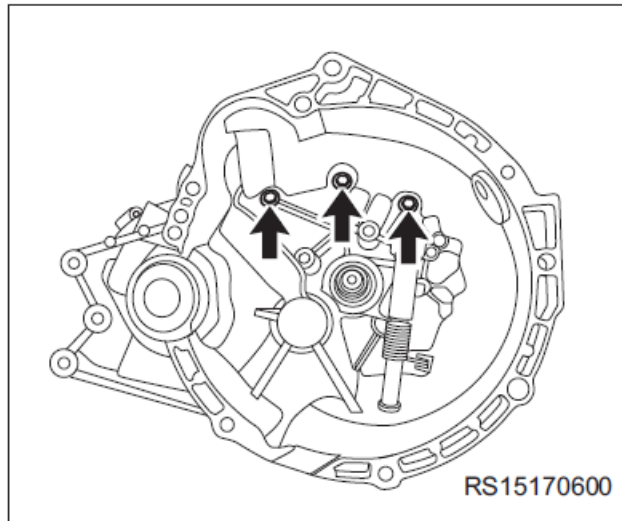
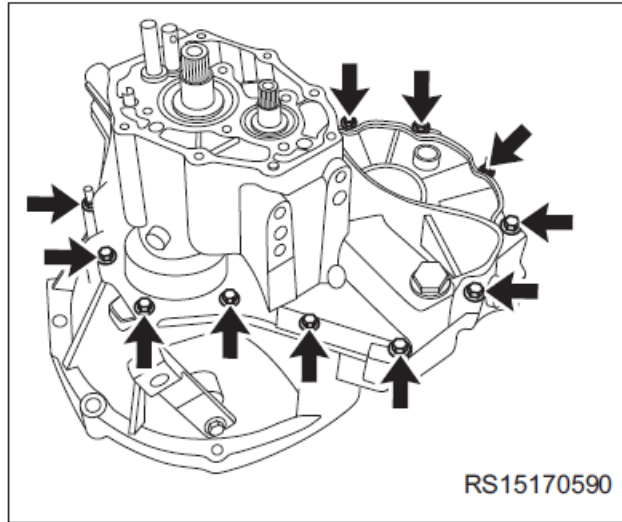

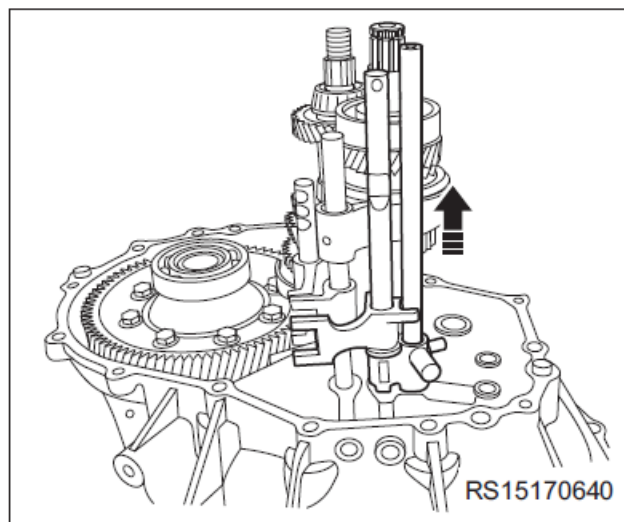
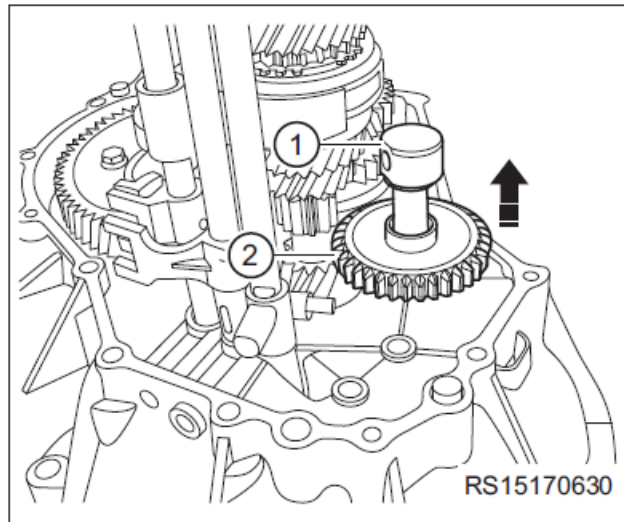
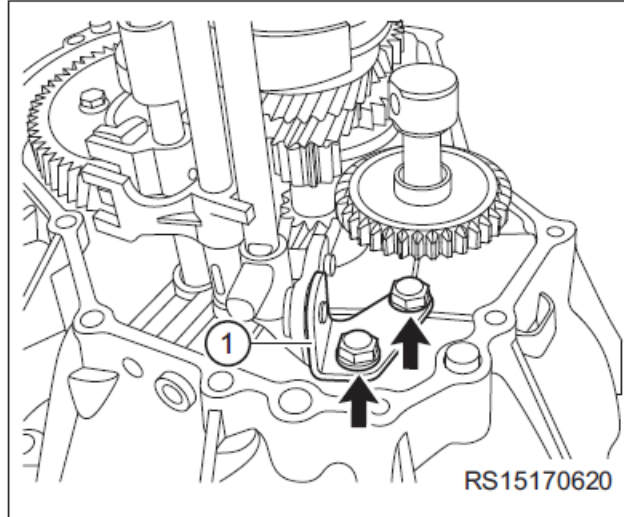

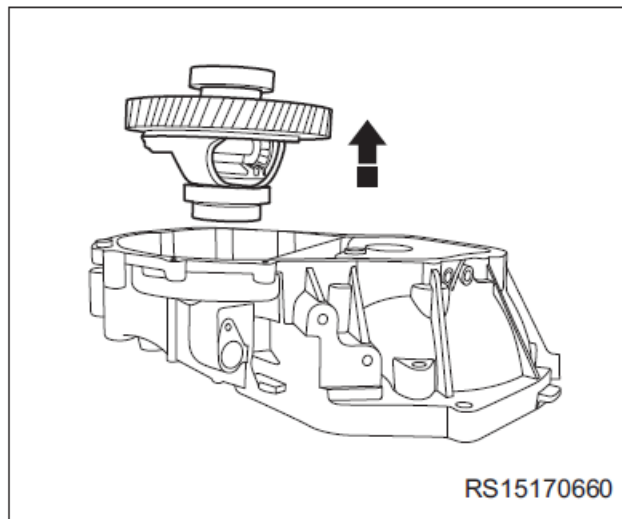
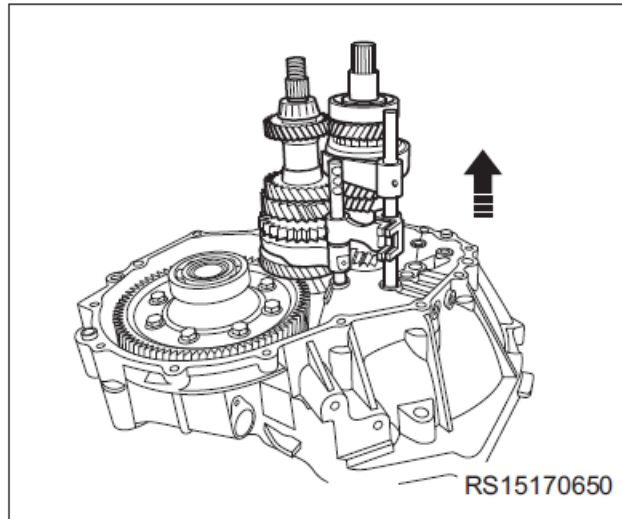

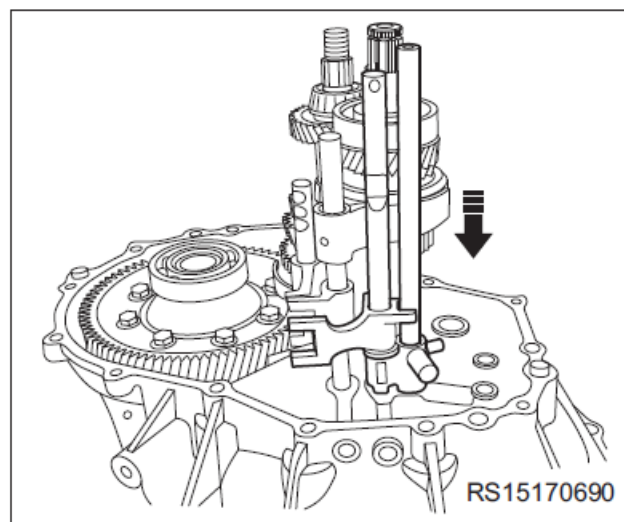
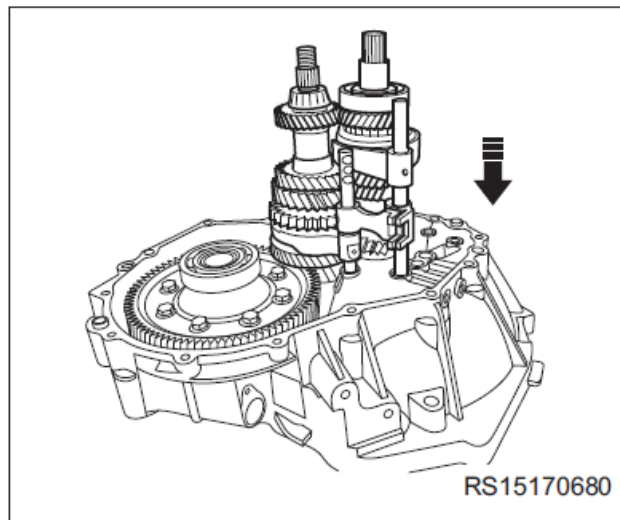
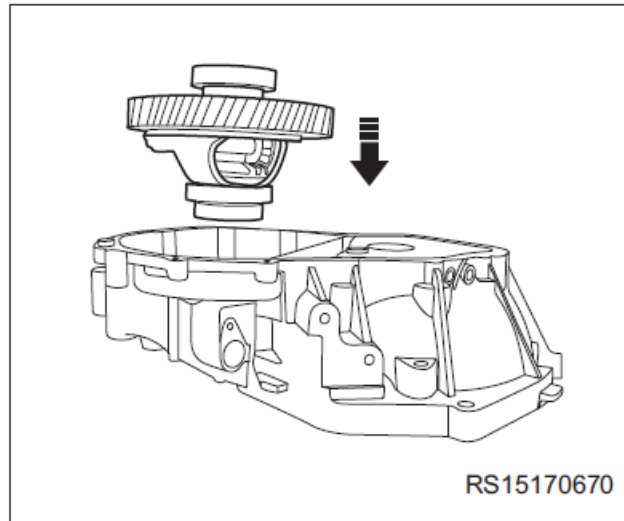

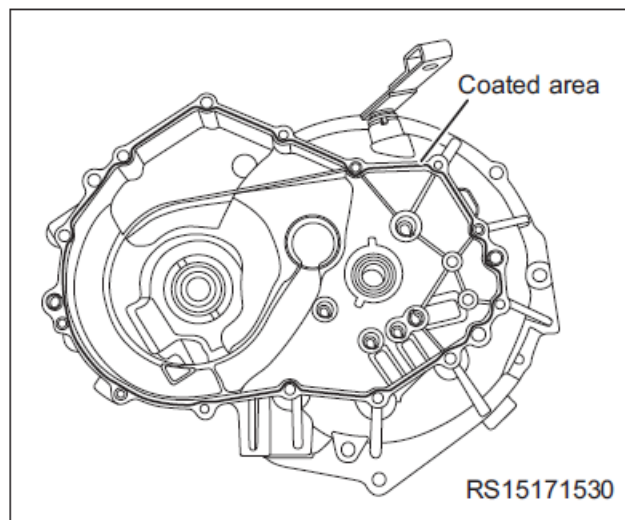
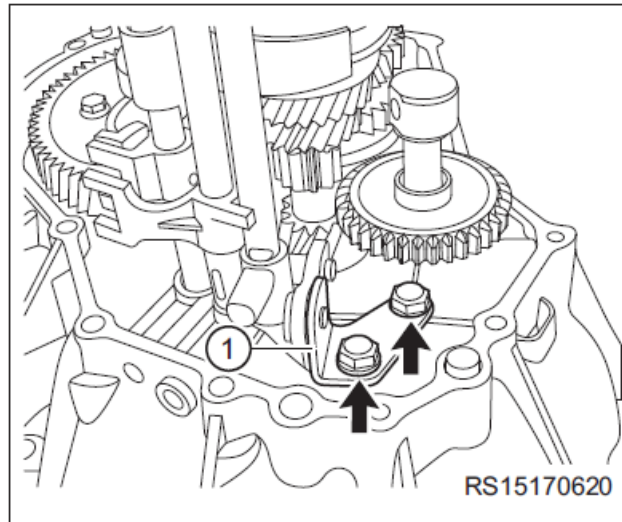
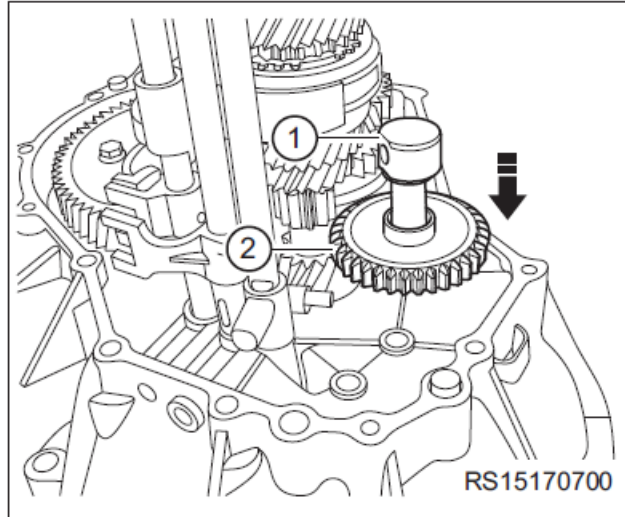

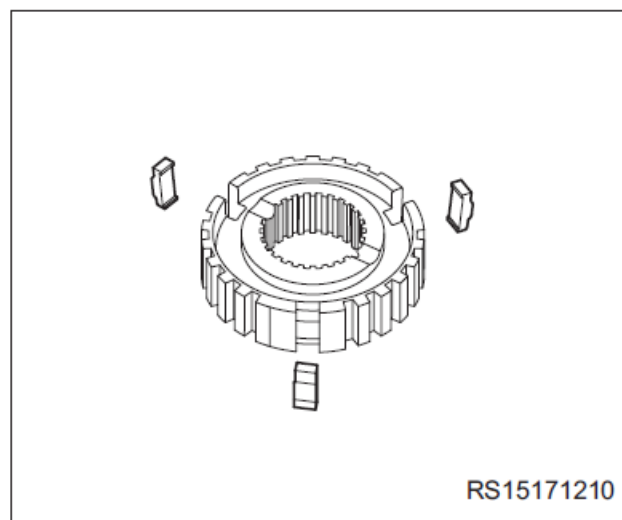
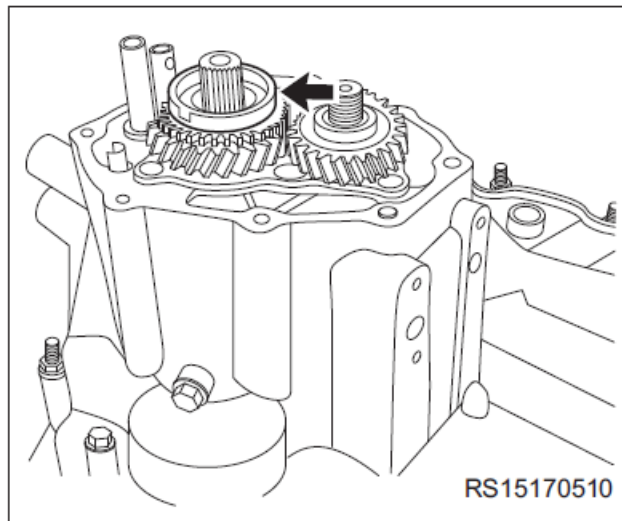
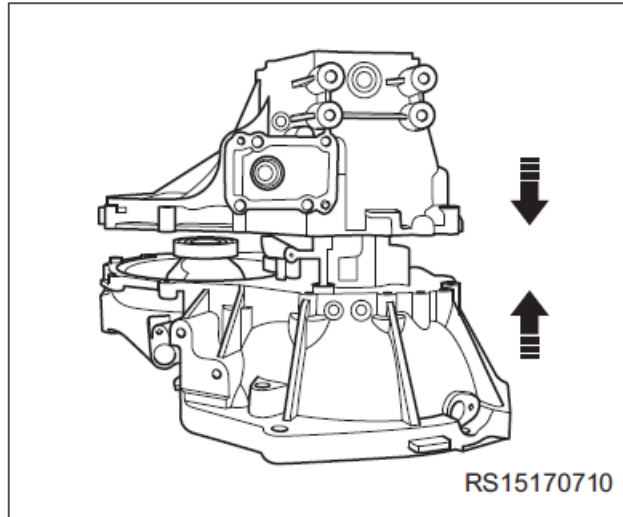

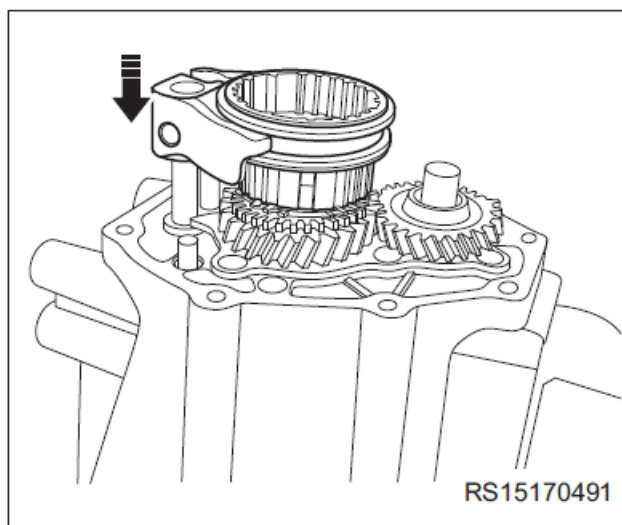
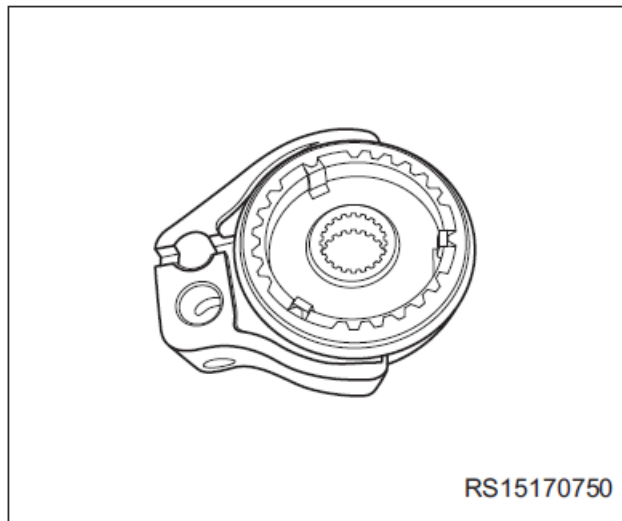
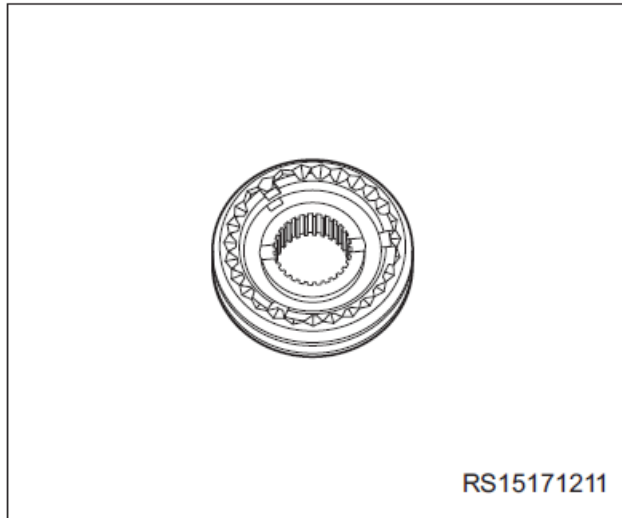

دمونتاژ شفت ورودی

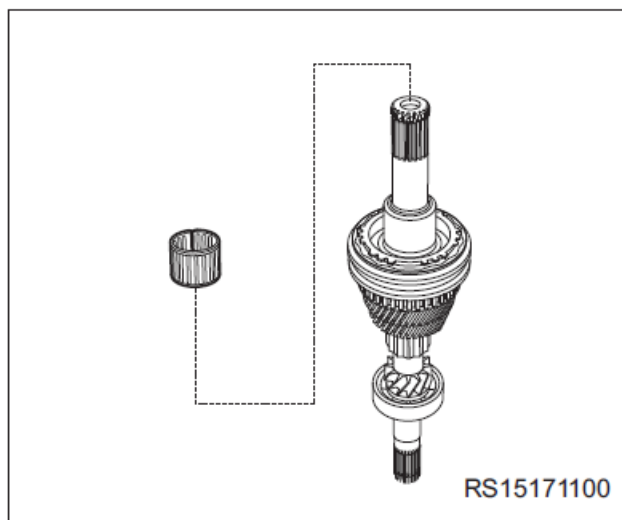
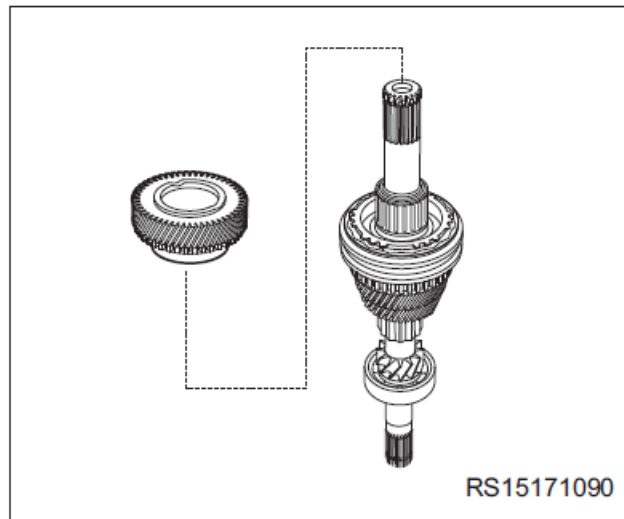
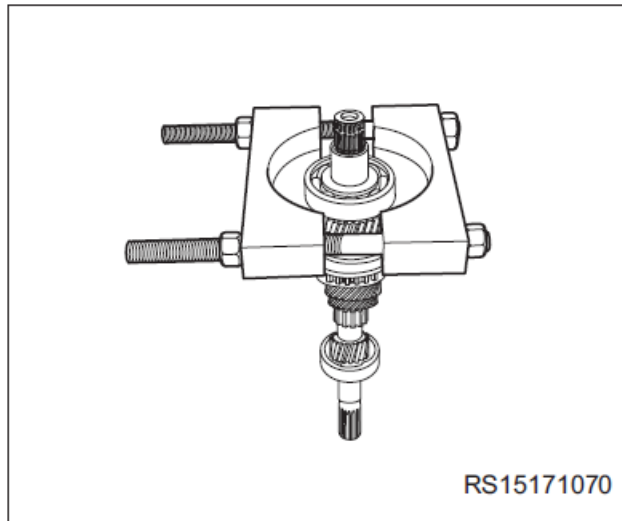

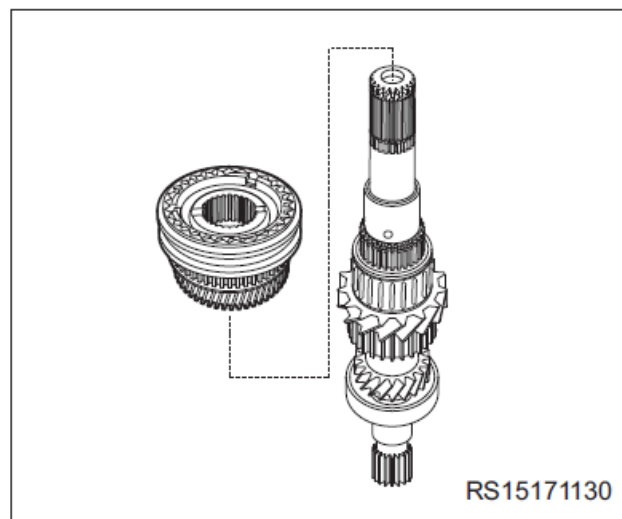
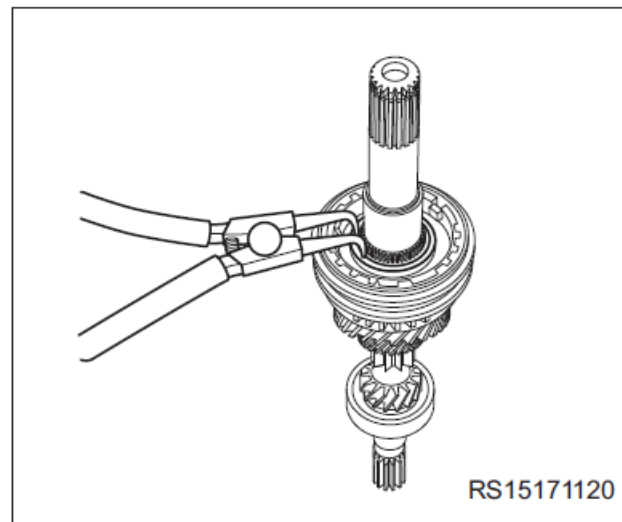
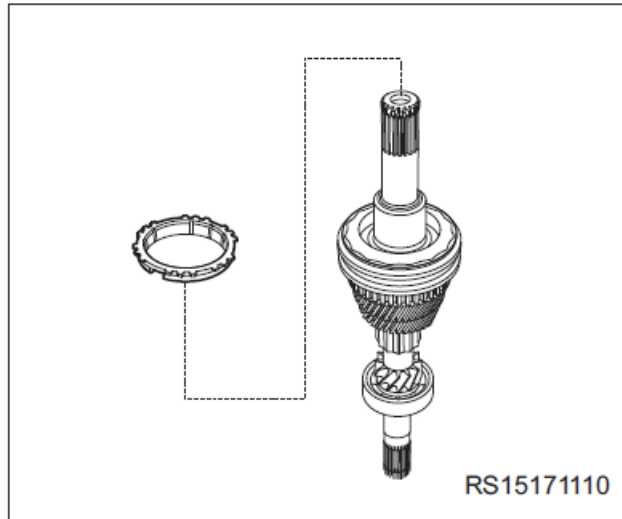

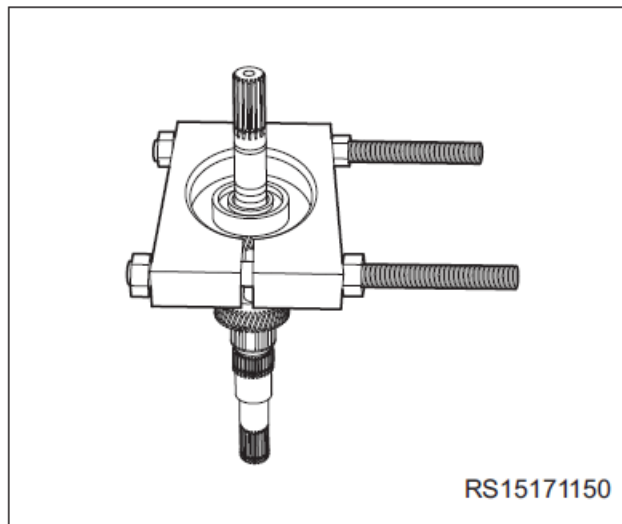
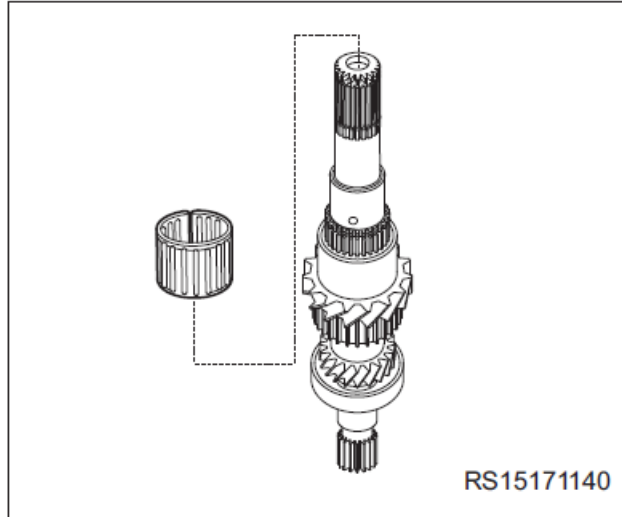

دمونتاژ شفت خروجی

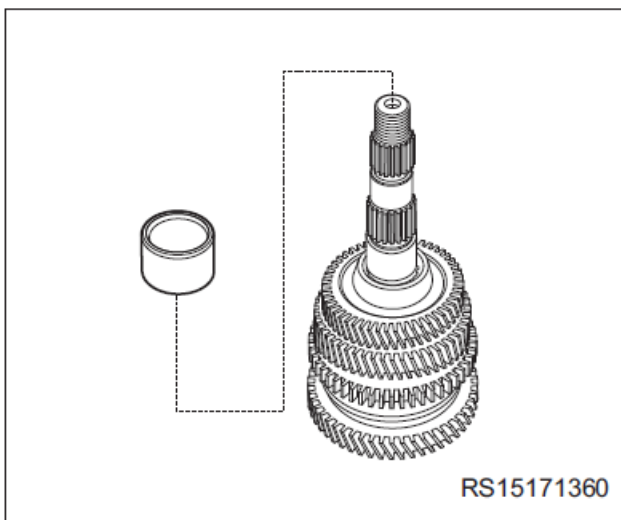
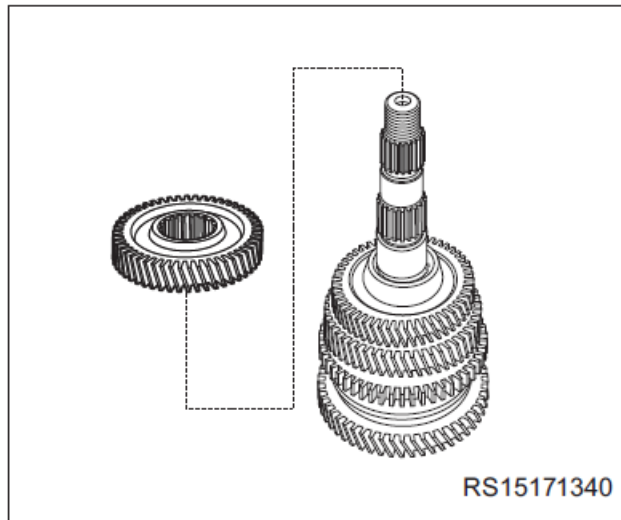
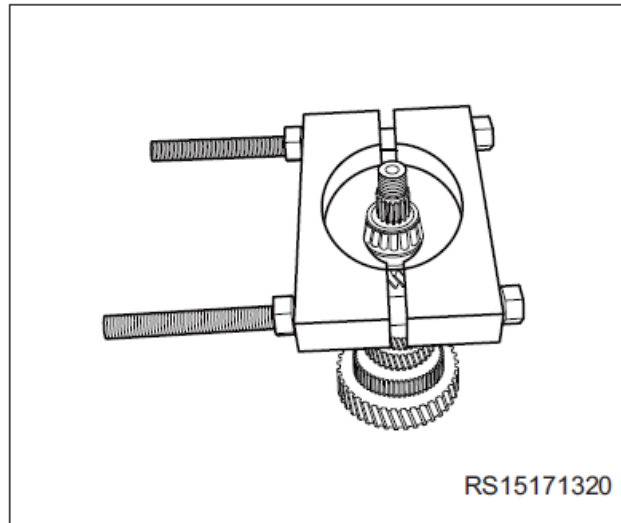

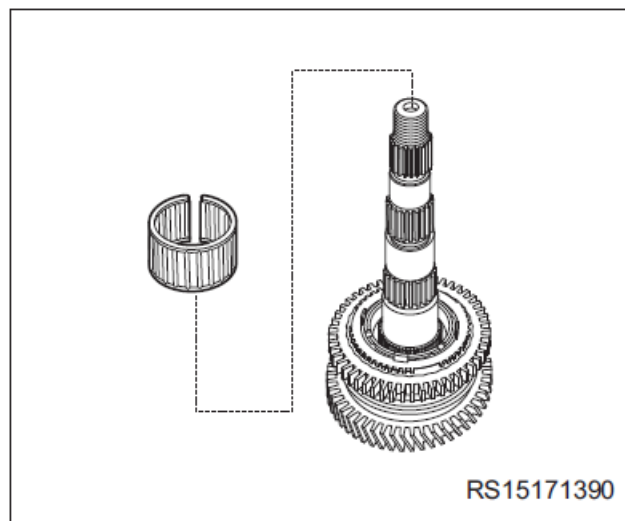
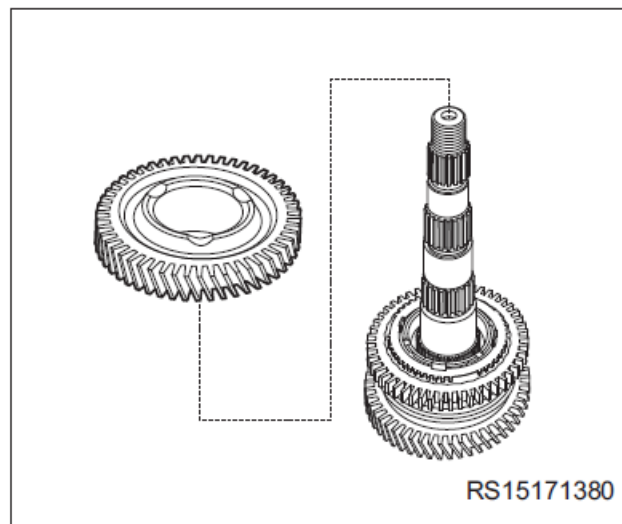
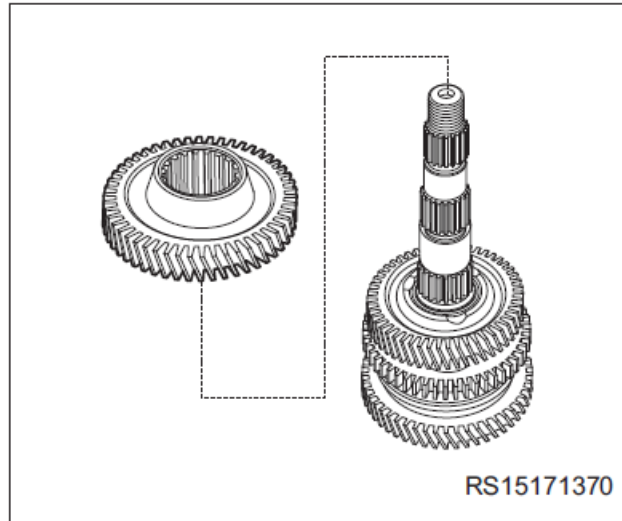

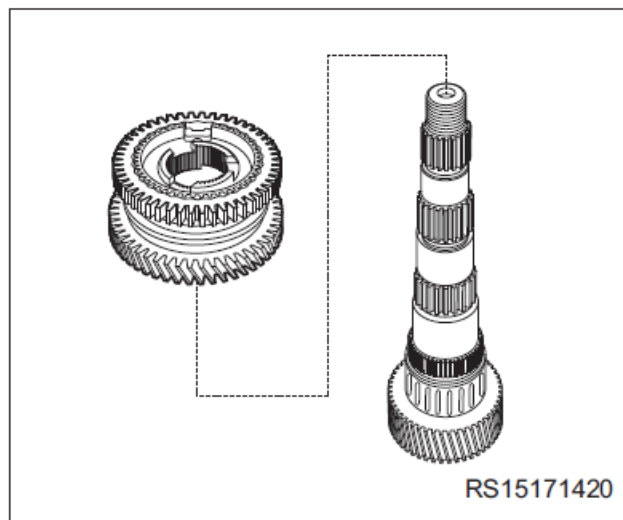
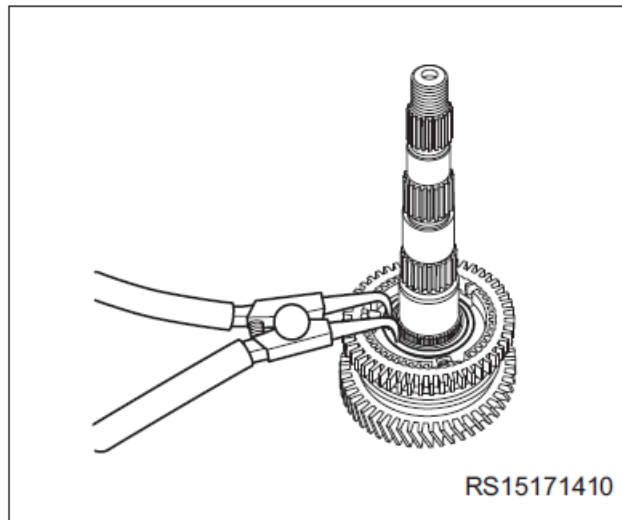
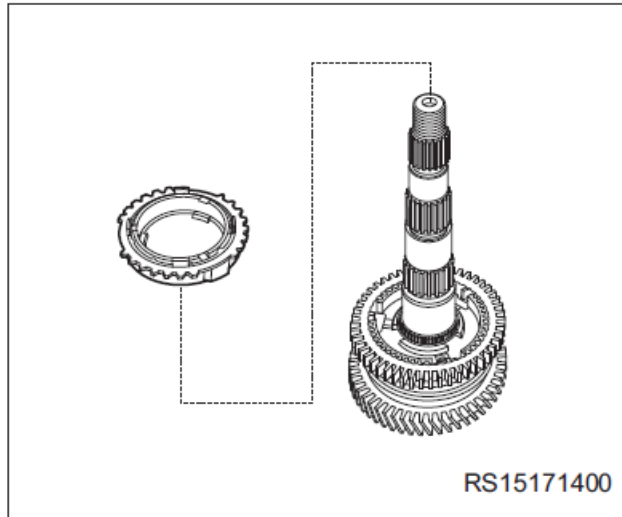

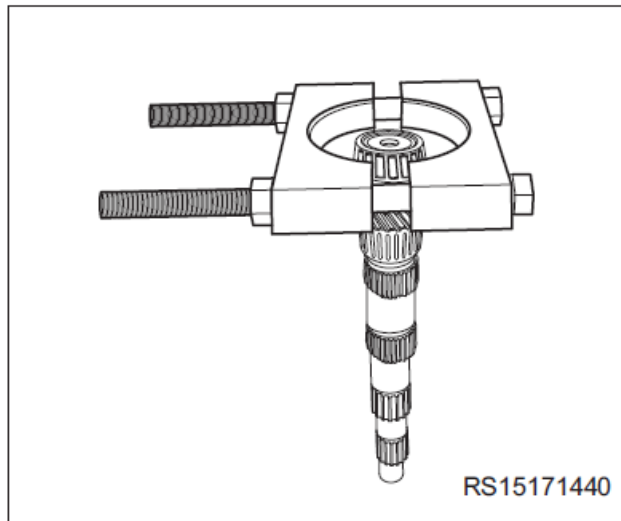
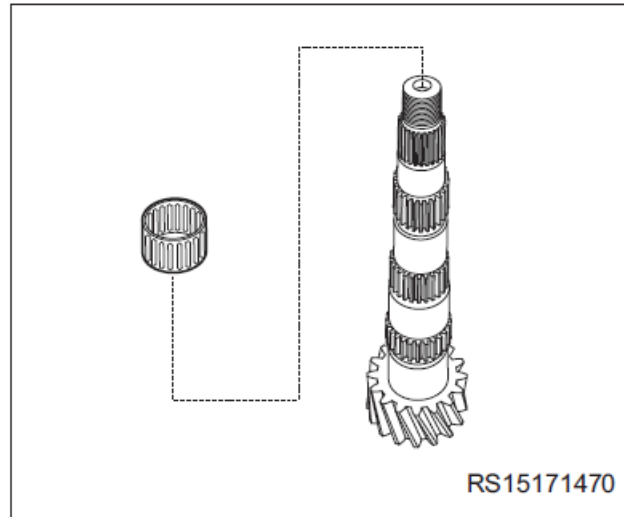

جهت بررسی ابزار مخصوص ها به لیست SPECIAL TOOLS مراجعه کنید.