

# Steering System

GENERAL .....	ST - 2
POWER STEERING SYSTEM .....	ST -12
MECHANICAL POWER STEERING SYSTEM .....	ST -16
EPS (ELECTRONIC POWER STEERING) SYSTEM .....	ST -33

## GENERAL

### SPECIFICATIONS EB02D03F





Item		Specifications	
Column and shaft	Shaft and joint type	Collapsible, Cross joint with tilt column	
	Steering gear type	Rack and Pinion	
	Rack stroke	142 ± 1 mm (5.6 ± 0.03 in.)	
	Tilt stroke	Non electrical	55.5 mm (2.2 in.)
		Electrical	66 mm (2.6 in.)
Telescopic stroke		29.2 mm (1.2 in.)	
Oil pump	Type	Vane type	
	Displacement	10.5 cc/rev	
	Relief pressure	100 ± 4 kg/cm <sup>2</sup>	
Steering angle	Inner	38.14° ± 2°	
	Outer	30.75°	



### LUBRICANTS E2DF0299

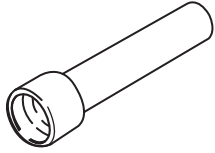
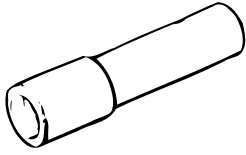

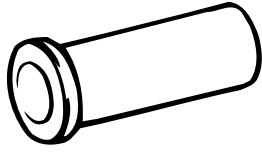
Items	Specified lubricant	Quantity
Steering column bearing	Multipurpose grease SAE J310a, NLGI No.2	As required
Steering gear box rack, pinion gear part	Multipurpose grease SAE J310a, NLGI No.2	As required
Bellows	Silicone grease	As required
Oil pump	Power steering fluid (PSF-3)	As required
Power steering fluid	Power steering fluid (PSF-3)	1.0 lit (0.88 qts.)

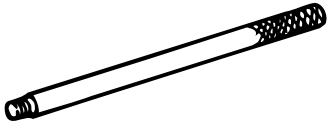
SPECIAL SERVICE TOOLS

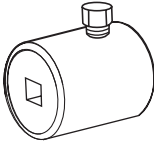
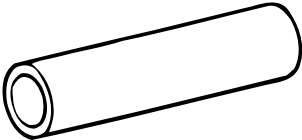
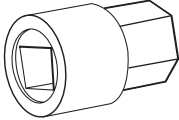
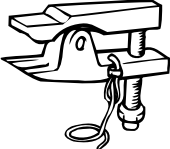
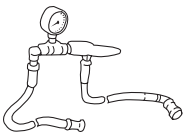
EF50AB3C

Tool (Number and Name)	Illustration	Use
09222-21100 Valve stem oil seal installer	 APCD002A	Installation of the pinion gear bearing
09222-32100 Valve stem oil seal installer	 APCD002B	Installation of the oil pump oil seal
09431-11000 Front oil seal installer	 APCD002D	Installation of the pinion gear oil seal
09432-21601 Bearing installer	 APCD002C	Installation of the pinion gear bearing
09517-21400 Drift	 APCD002E	1. Removal of pinion gear bearing 2. Removal of pinion bearing outer race
09555-21000 Bar	 APCD002F	Removal and installation of the oil seal (Use with 09573-33100, 09573-33000, 09573-21000)

Tool (Number and Name)	Illustration	Use
09565-11100 Pre-load socket	 APCD002H	Measurement of the main shaft pre-load
09565-21000 Pinion bearing remover and installer	 APCD002I	Removal and installation of pinion gear bearing
09565-31300 Yoke plug torque wrench socket	 APCD002J	Removal, installation and adjustment of steering gear yoke plug
09568-34000 Ball joint remover	 AHCD010L	Separation of the tie rod end bail joint
09572-21000 Oil pressure gauge	 APCD002L	Measurement of the oil pressure (Use with 09572-33100, 09572-21200)
09572-21200 Oil pressure gauge adapter	 APCD002M	Measurement of the oil pressure (Use with 09572-21000, 09572-33100)
09572-33100 Oil pressure gauge adapter	 APCD002N	Measurement of the oil pressure (Use with 09572-21000, 09572-21200)

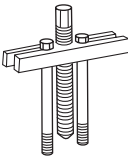
Tool (Number and Name)	Illustration	Use
09573-21000 Oil seal installer guide	 <small>APCD002O</small>	Installation of the back up washer and oil seal (Use with 09573-33000, 09573-33100, 09555-21000)
09573-33000 Oil seal installer	 <small>APCD002P</small>	Installation of the back up washer and oil seal (Use with 09573-21000, 09573-33100, 09555-21000)
09573-33100 Oil seal guide	 <small>APCD002Q</small>	Removal and installation of the oil seal (Use with 09573-21000, 09573-33000, 09555-21000)
09561-11001 Steering wheel puller	 <small>APCD002G</small>	Removal of steering wheel

TROUBLESHOOTING

E22EDCC4

Symptom	Probable cause	Remedy
Steering wheel return malfunction	Incorrect tire pressure	Adjust the tire pressure
Steering operation is "hard"	Incorrect tire pressure	Adjust the tire pressure
	Loose belt	Adjust the belt tension
	Damaged belt	Replace the belt
	Low fluid level	Refill fluid
	Air in fluid line	Bleed air
Steering wheel pulls to one side	Twisted hose	Correct the hose routing or replace the hoses
	Incorrect mounting of the steering gear box on the cross membe	Retighten
	Fluid leakage	Check the fluid leakage and retighten or replace
	Incorrect wheel alignment (especially caster)	Adjust the wheel alignment
	Malfunction of gear box	Check and replace the gear box if necessary
	Malfunction of oil pump	Check the oil pump pressure and repair oil pump
	Excessive steering wheel play	Adjust the steering wheel play
	Insufficient tire inflation pressure	Adjust the tire pressure
	Unevenly worn or deformed tire	Rotate the wheel or replace the tire
	Dragging brake	Adjust
	Deteriorated or broken front spring	Replace
	Deformed knuckle arm	Replace
	Poor wheel alignment	Adjust the wheel alignment
	Damaged wheel bearing	Replace
	Deformed or loose lower arm	Retighten or replace
	Loose linkage joints	Retighten
	Malfunction of ball joints (Too small ball joint starting torque)	Replace
	Deteriorated or broken lower arm bushing	Replace
Incorrect installation of internal damage to gear	Correct or replace	
Malfunction of shock absorber	Replace	

Symptom	Probable cause	Remedy
Steering wheel vibrates	Insufficient tire inflation pressure	Adjust the tire pressure
	Unevenly worn or deformed tire(s)	Rotate the wheels or replace the tire(s)
	Loose hub nut	Retighten
	Excessive run out, or unbalance of tire and wheel	Adjust the wheel balance or replace
	Poor wheel alignment	Adjust the wheel alignment
	Damaged wheel bearing	Replace
	Deformed or loose lower arm	Retighten or replace
	Deformed linkage	Repair or replace
	Loose linkage joints	Retighten
	Malfunction of ball joints (Too small ball joint starting torque)	Replace
	Malfunction of front suspension	Check and adjust; replace the parts if necessary
	Incorrect installation or internal damage in gear box	Correct or replace
	Malfunctioning of shock absorber	Replace
Road shock is felt in steering wheel	Insufficient steering wheel play	Adjust the steering wheel play
	Insufficient tire inflation pressure	Adjust the tire pressure
	Unevenly worn or deformed tire(s)	Rotate the wheels or replace the tire(s)
	Malfunction of shock absorber	Replace
Poor recovery of steering wheel to straight ahead position	Insufficient tire inflation pressure	Adjust the tire pressure
	Stuck or damaged ball joint improper	Replace
	Wheel alignment angles	Adjust the wheel alignment
Rattling noise	Loose installation of oil pump or gear box	Retighten the oil pump and gear box
	Steering linkage looseness or play	Retighten or replace the steering linkage
	Loose oil pump pulley nut	Retighten the oil pump pulley nut
	Interference around column or between pressure hose and other parts	Correct or replace the pressure hose and the parts around the column
	Abnormal noise inside the gear box and oil pump	Replace the gear box or oil pump
Strident noise	Air sucked into oil pump	Check the oil level and hose clips; bleed the system or replace the oil pump
	Seizure inside oil pump	Replace the oil pump
Squealing noise 1)	Loose belt	Adjust the belt tension
	Seizure inside oil pump	Replace the oil pump
Hissing noise	Air sucked into oil pump	Check the oil level and hose clips; bleed the system
	Damage to the gear box port section	Replace the gear box
	Malfunction of return hose	Replace the hose
Whistling noise	Malfunction of gear box port section	Replace the gear box

Symptom	Probable cause	Remedy
Droning noise	Loose mounting bolt on oil pump or oil pump bracket	Retighten the pump bracket and pump installing bolt
	Poor condition of oil pump body 2)	Replace the oil pump
Squeaking noise 2)	Malfunction of steering stopper contact	Check and adjust the steering stopper
	Interference of wheel with vehicle body	Adjust the steering angle
	Interference of steering shaft and joint assembly with other parts	Reposition the interfering parts
	Malfunction of gear box	Replace the gear box
Shuddering vibration 3)	Air suction	Bleed the system
	Malfunction of gear box	Replace the gear box
Oil leakage from hose connection	Improperly tightened flare nut	Check, repair or replace
	Incorrectly inserted hose	
	Improperly clamped hose	
Oil leakage from hose assembly	Damaged or clogged hose	Replace
	Hose connector malfunction	
Oil leakage from oil reservoir	Leaking reservoir	Replace
	Overflow	Bleed the system or adjust the oil level
Oil leakage from oil pump	Malfunction of oil pump housing	Replace the oil pump
	Malfunction of O-ring and/or oil seal	Replace the O-ring and oil level
Oil leakage from gear box	Malfunction of gear box housing (including leakage from air hole)	Replace the gear box
	Malfunction of O-ring and/or oil seal	Replace the O-ring and oil seal

 **NOTE**

1. A squealing noise may be heard just after very cold engine start (-20° or less), caused by fluid characteristics at extreme low temperatures. This is not a malfunction.
2. A slight "beat noise" is produced by the oil pump; this is not a malfunction. (This noise occurs particularly when a stationary steering effort is made.)
3. A slight vibration may be felt when a stationary steering effort is made due to the condition of the road surface. To check whether the vibration actually exists or not, test-drive the vehicle on a dry concrete or asphalt surface. A very slight amount of vibration is not a malfunction.

**SERVICE ADJUSTMENT**

**PROCEDURE** E0A7AF5E

**CHECKING STEERING WHEEL FREE PLAY**

1. Start the engine and with the steering wheel in the straight ahead position.
2. Measure the play while turning the steering wheel to the left and right.

---

Standard value  
Steering wheel free play : 30 mm (1.1 in.)

---

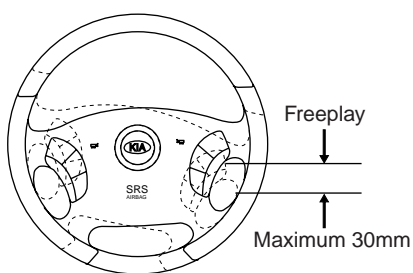

LPCD004A

3. If the play exceeds the standard value, inspect the connection between the steering shaft and tie rod ends.

**CHECKING STEERING ANGLE**

1. Place the front wheel on a turning radius gauge and measure the steering angle.

---

Standard value  
Wheel angle  
Inside wheel :  $38.14^\circ \pm 2^\circ$   
Outside wheel :  $30.75^\circ$

---

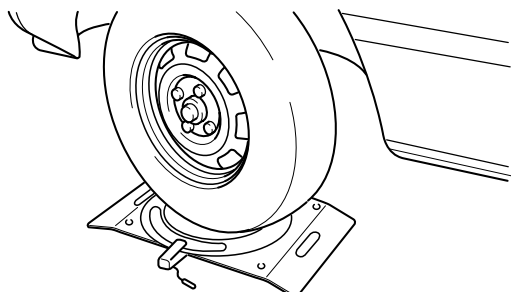

APCD004B

2. If the measured value is not within the standard value, adjust the toe and inspect again.

**CHECKING STEERING WHEEL RETURN**

Check the steering wheel return and confirm the following points :

1. The force required to turn the steering wheel and the wheel return should be the same for both moderate and sharp turns.
2. When the steering wheel is turned 90° and held for a couple of seconds while the vehicle is being driven at 20-30 kph (12-19 mph), the steering wheel should return at least 20° from its central position when it is released.

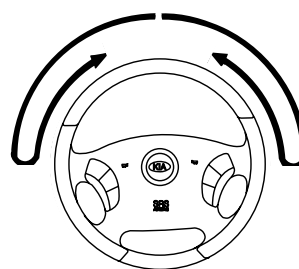

LPCD004E

 **NOTE**

*If the steering wheel is turned very quickly, steering may be momentarily difficult. This is not a malfunction because the oil pump output will be somewhat decreased.*

**CHECKING THE TIE ROD END BALL JOINT STARTING TORQUE**

1. Disconnect tie rod and knuckle with the special tool (09568-31000).
2. Shake the ball joint stud several times.
3. Mount two jam nuts on the ball joint, and then measure the ball joint starting torque.

---

Standard value  
0.5-2.5 N·m (5-25 kg·cm, 0.36-1.81 lb·ft)

---

4. If the starting torque exceeds the upper limit of the standard value, replace the tie rod end.

5. Even if the starting torque is below the lower limit of the standard value, check the play of the ball joint and installation.

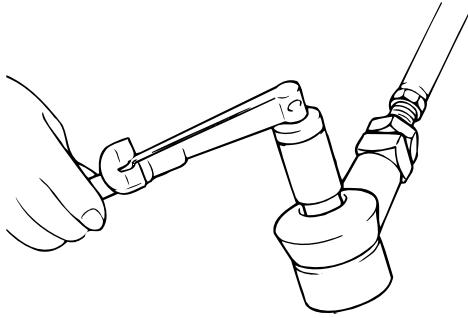

APCD004D

### CHECKING POWER STEERING FLUID LEVEL

1. Position the vehicle on a level surface.
2. Start the engine. With the vehicle kept stationary, turn the steering wheel several times continuously to raise the fluid temperature to 50-60 (122-140 ).
3. With the engine at idle, turn the steering wheel fully clockwise and counter-clockwise several times.
4. Make sure that there is no foaming or cloudiness in the reservoir fluid.
5. Stop the engine and check for any difference in fluid level between a stationary and a running engine.

#### NOTE

- If the fluid level varies 5mm (0.2 in.) or more, bleed the system again.
- If the fluid level suddenly rises after stopping the engine, further bleeding is required.
- Incomplete bleeding will produce a chattering sound in the pump and noise in the flow control valve, and lead to decreased durability of the pump.

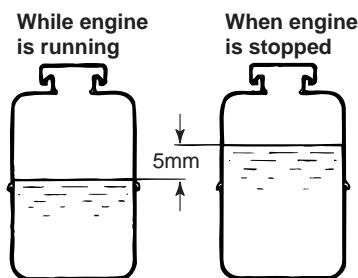

Difference in fluid levels : within 5mm

LPD004F

### REPLACING POWER STEERING FLUID

1. Jack up the front wheels and support them with jack-stands.
2. Disconnect the return hose from the oil reservoir and plug the oil reservoir.
3. Connect a vinyl hose to the disconnected return hose, and drain the oil into a container.
4. Disconnect the high-tension cable at the ignition coil side. While operating the starter motor intermittently, turn the steering wheel all the way to the left and then to the right several times to drain the fluid.
5. Connect the return hoses, and then fill the oil reservoir with the specified fluid.
6. Start the engine. Check for oil leakage.
7. Stop the engine.
8. Bleed the system.

---

Power steering fluid type : PSF-III  
Total quantity : Approx 1.0 liter

---

### AIR BLEEDING

1. Disconnect the high tension cable, and while operating the starting motor intermittently (for 15-20 seconds), turn the steering wheel all the way to the left and then to the right five or six times.

#### NOTE

- During air bleeding, replenish the fluid supply so that the level never falls below the lower position of the filter.
- If air bleeding is done while the vehicle is idling, the air will be broken up and absorbed into the fluid. Be sure to do the bleeding only while cranking.

2. Disconnect the high tension cable, and start the engine (idling).
3. Turn the steering wheel to the left and the right until there are no air bubbles in the oil reservoir.

#### CAUTION

**Do not hold the steering wheel turned all the way to either side for more than ten seconds.**

4. Confirm that the fluid is not milky, and that the level is up to the position specified on the level gauge.

- Confirm that there is little change in the surface the fluid when the steering wheel is turned left and right.

**CAUTION**

- If the surface of the fluid changes considerably, air bleeding should be done again.
- If the fluid level rises suddenly when the engine is stopped, it indicates that there is still air in the system.
- If there is air in the system, a jingling noise may be heard from the pump and the control valve may also produce unusual noises. Air in the system will shorten the pump and other parts.

**CHECKING POWER STEERING BELT TENSION**

- Press the belt applying a pressure of 98N (10kg, 22lb) at the specified point, and measure the deflection to confirm that it is within the standard value range.

---

Standard value
Drive belt deflection
Regular inspection : 11.7-15.3 mm (0.46-0.60 in.)
New one : 8.8-11.0 mm (0.35-0.43 in.)

---

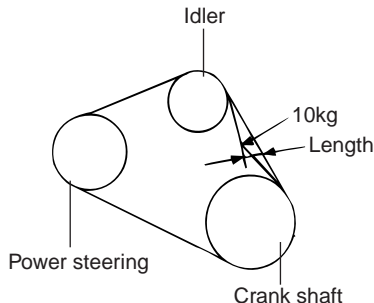

LPCD004G

- To adjust the belt tension, auto tensioner does automatically adjust to obtain the standard value.

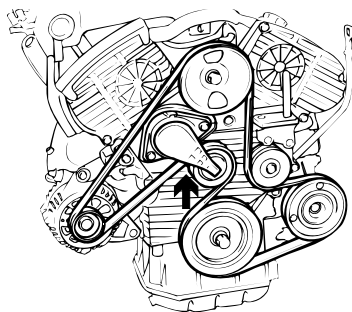

APCD004H

- Temporarily install hinge bolt and flange nut not to tensioner pulley run out. Adjust belt tension. Tighten adjust bolt and flange nut to the specified torque.

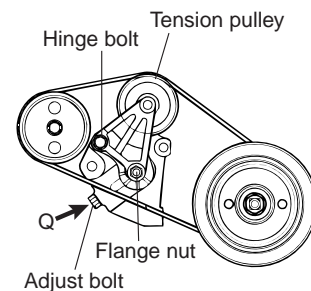

LPCD004I

**OIL PUMP PRESSURE TEST (OIL PUMP RELIEF PRESSURE)**

- Disconnect the pressure hose from the oil pump. Connect the special tool between the oil pump and pressure hose as illustrated.
- Bleed the air, and then start the engine and turn the steering wheel several times so that the fluid temperature rises to approximately 50 (122 ).
- Set the engine speed to 1,000 rpm.
- Close the shut-off valve of the special tool and measure the fluid pressure to confirm it is within the standard value range.

[V6 ENG.]

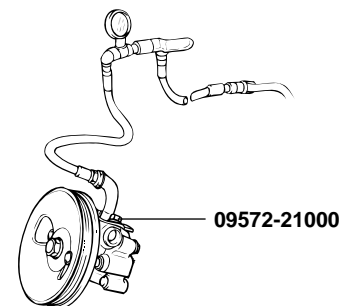

APCD004J

---

Standard value
Oil pump pressure
Gauge hose valve closed :
81-88kg/cm <sup>2</sup> (953-1,035psi) or less

---

**CAUTION**

*Don't keep the shut-off valve on the pressure gauge closed for longer than seconds.*

- Remove the special tools, and tighten the pressure hose to the specified torque.

---

Tightening torque : 53.9-63.7 N·m (5.5-6.5 kg·m, 39.8-47 lb·ft)
---

---

- Bleed the system.

# POWER STEERING SYSTEM

## STEERING COLUMN AND SHAFT

### COMPONENTS ECAD7A20

[Electrical]

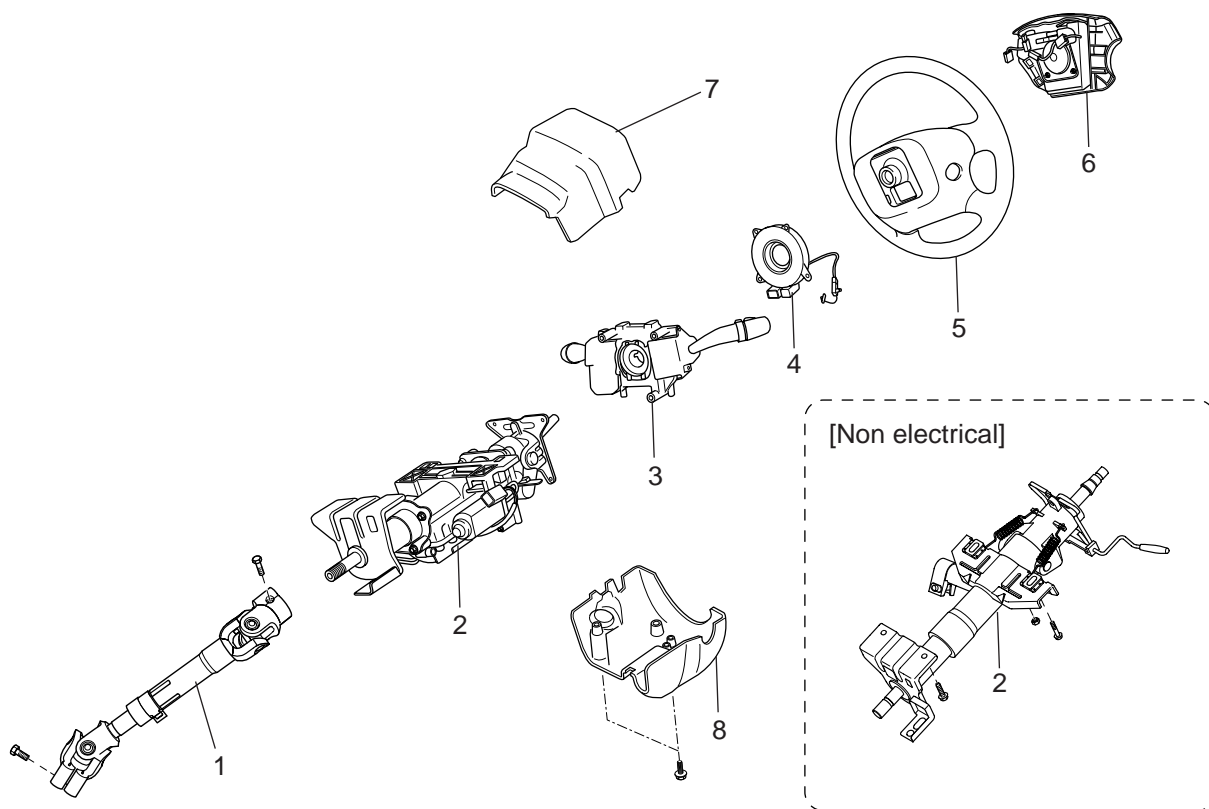

Tightening torque : N·m (kg·m, lb·ft)

- 1. Wheel joint assembly
- 2. Steering column
- 3. Multi function switch
- 4. Clock spring

- 5. Steering wheel
- 6. Air bag module
- 7. Steering column upper shroud
- 8. Steering column lower shroud

REMOVAL EE6DA49C

1. Loosen the tapping screws and lift up the air bag module and remove it.

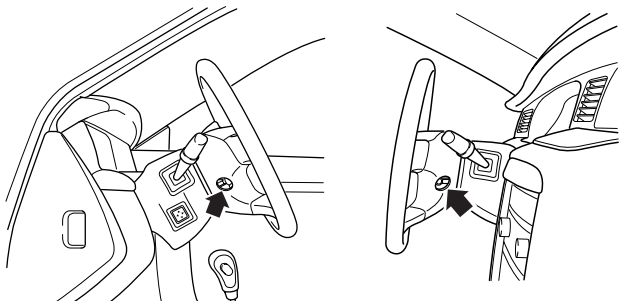

APCD007A

2. Remove the lock nut and the washer.

**CAUTION**

Before doing these procedures, see the SRS section (RT Group. Only for vehicle equipped with SRS).

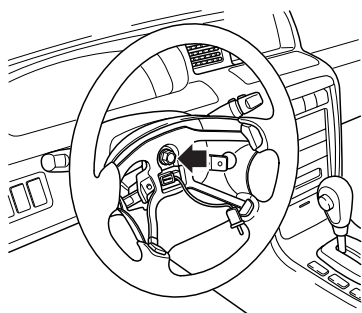

APCD007B

3. Remove the steering wheel with SST (09561-11001).

**CAUTION**

Do not hammer on the steering wheel to remove it; doing so may damage the collapsible mechanism.

4. Remove the steering column lower and upper shrouds.

5. Remove the lower cover.

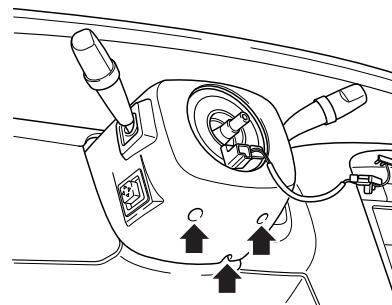

APCD007C

6. Disconnect the connectors and remove the multifunction switch.

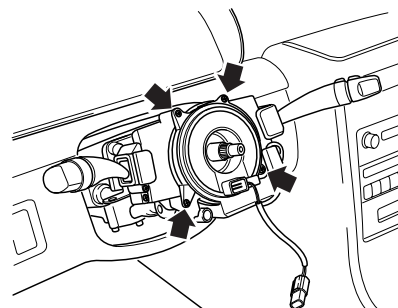

APCD007D

7. Remove the bolts securing the coupling and universal joint. Pull out the universal joint from the gear box.

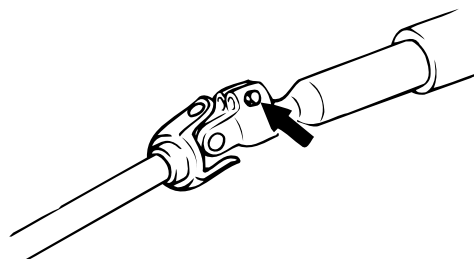

APCD007E

8. Remove the wheel joint assembly.

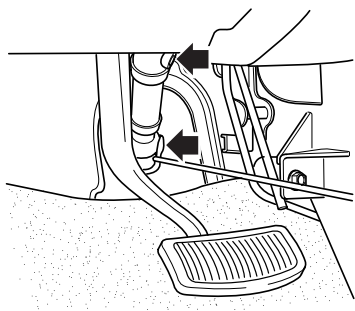

APCD007F

9. Remove the steering column and shaft with the universal joint and cover.

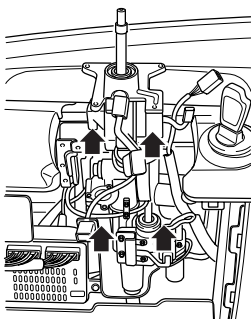

APCD007G

### INSPECTION EC4EADC0

1. Check the steering shaft for damage, play and round movement.
2. Check the upper and lower bearing for wear or damage.
3. Check the joints for excessive play, damage or rough movement.
4. Check the tilt bracket for cracks or damage.
5. Check the cover or boot for damage.
6. Check that the steering lock mechanism operates properly. If necessary, replace.

### INSTALLATION E7CB80E8

1. Before installation, apply multipurpose grease to the groove inside the bearing and contracting surfaces of the boot and cover assembly.
2. Install the steering and shaft.

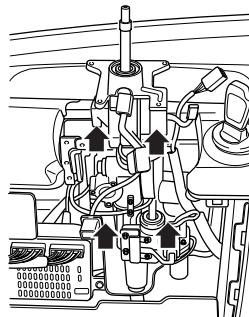

APCD007G

---

Tightening torque : 12.7-17.7 N·m (1.3-1.8 kg·m, 9.4-13 lb·ft)

---

3. Install the wheel joint assembly.

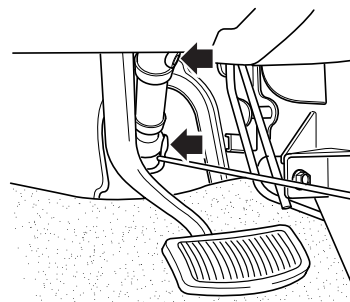

APCD007F

---

Tightening torque : 14.7-19.6 N·m (1.5-2.0 kg·m, 10.8-14.5 lb·ft)

---

4. Install the multifunction switch and connect the connectors.

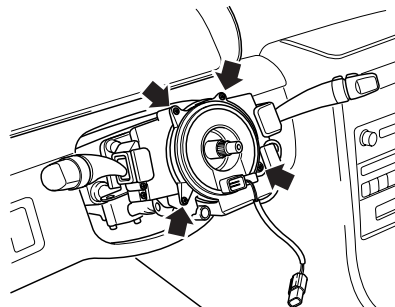

APCD007D

5. Install the steering column upper and lower shroud and lower cover.

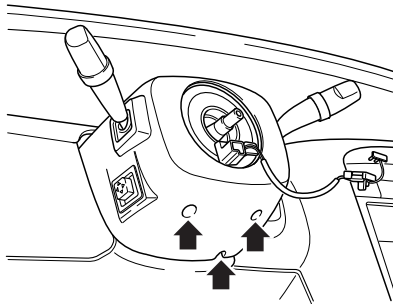

APCD007C

6. Install the steering wheel.

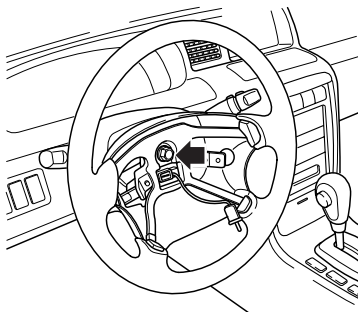

APCD007B

---

Tightening torque : 39.2-49 N·m (4-5 kg·m,  
28.9-36.2 lb·ft)

---

7. Install the air bag module.

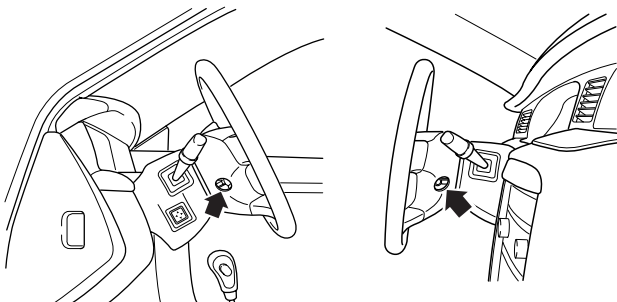

APCD007A

---

Tightening torque : 7.8-10.8 N·m (0.8-1.1  
kg·m, 5.8-8 lb·ft)

---

# MECHANICAL POWER STEERING SYSTEM

## POWER STEERING GEAR BOX

### COMPONENTS ECBCA1C8

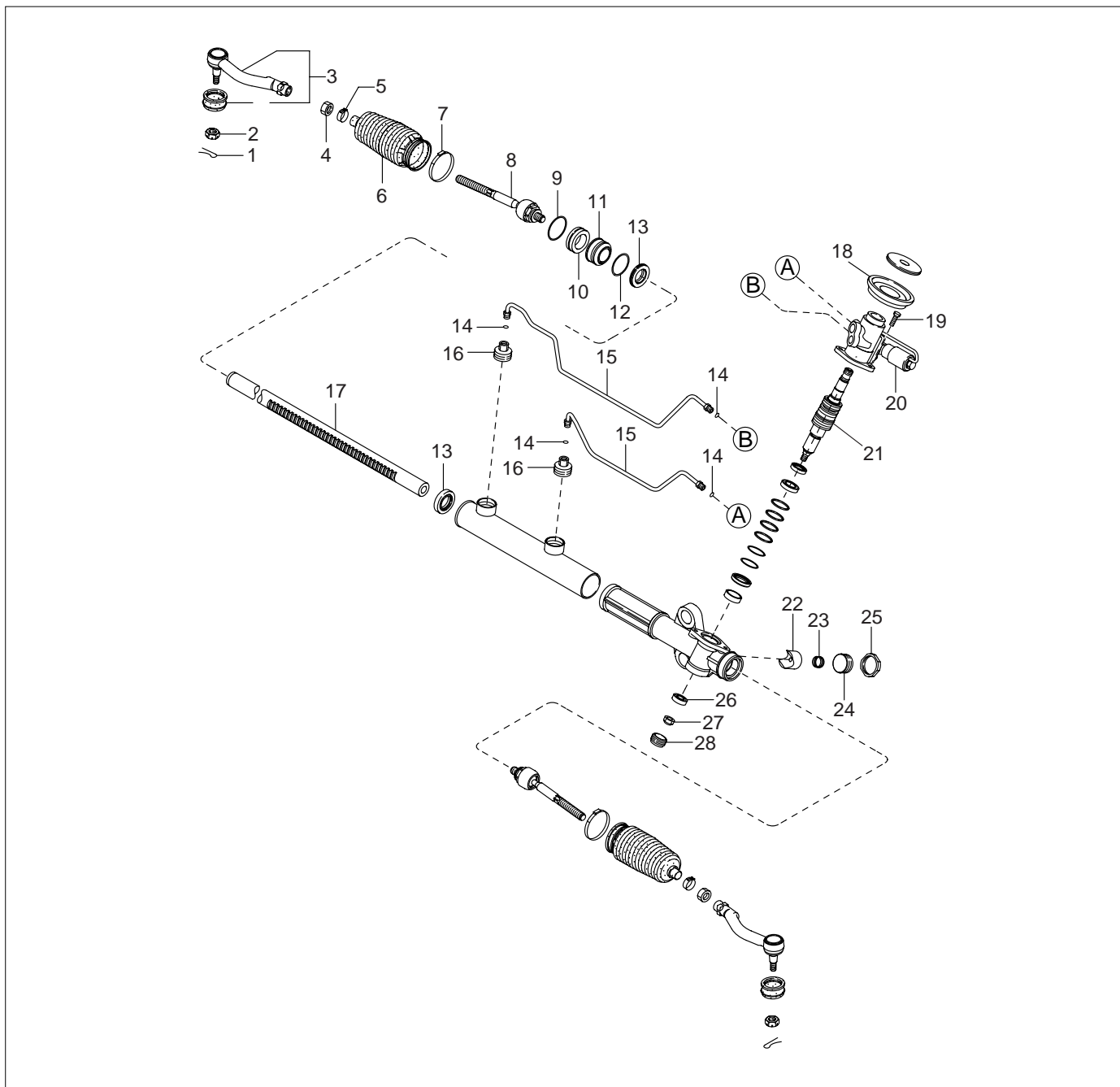

- |                         |                    |                             |                      |
|-------------------------|--------------------|-----------------------------|----------------------|
| 1. Sprit pin            | 8. Tie rod         | 15. Pressure hose           | 22. Yoke assembly    |
| 2. Nut                  | 9. Rack bushing    | 16. Damper valve assembly   | 23. Yoke spring      |
| 3. Tie rod end assembly | 10. Insert bushing | 17. Rack bar                | 24. Yoke cover       |
| 4. Lock nut             | 11. O-ring housing | 18. Protector               | 25. Yoke nut         |
| 5. Clip                 | 12. Oil seal       | 19. Cut off plug            | 26. Ball bearing     |
| 6. Bellows              | 13. Rack stopper   | 20. Solenoid valve assembly | 27. Self locking nut |
| 7. Steel band           | 14. Packing        | 21. Valve assembly          | 28. Pinion plug      |

## MECHANICAL POWER STEERING SYSTEM

ST -17

### REMOVAL E9DC7AA9

1. Drain the power steering fluid.
2. Remove the pressure hose and return tube.
3. Remove the joint assembly connecting bolt.

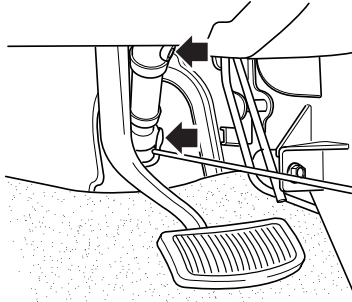

APCD007F

4. Using the special tool (09568-34000), disconnect the tie rod end from the knuckle arm.

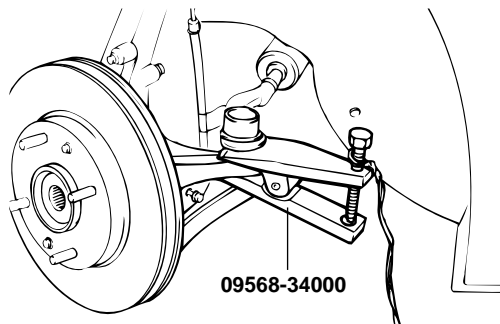

APCD004C

5. Disconnect the front muffler temporarily.

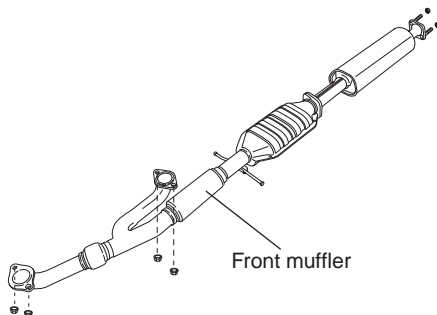

LPCD500V

6. Remove the connecting bolts of front and rear roll stopper.

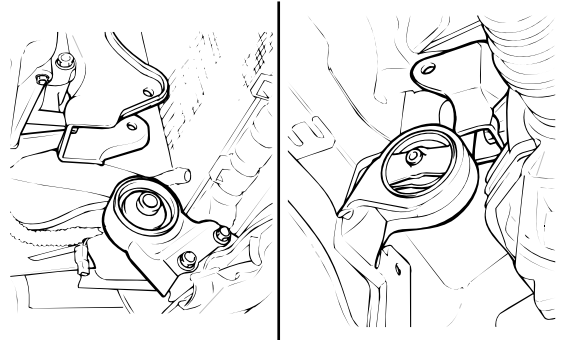

APCD020D

7. Remove the mounting bolts (6EA) of cross member complete assembly.

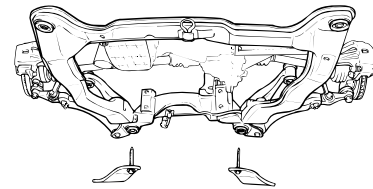

APCD020E

8. Disconnect the pressure hose and the return tube.

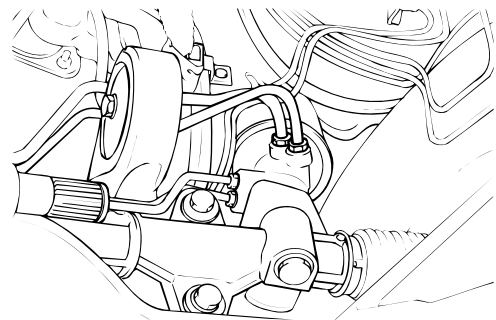

APCD020J

9. Remove the steering gear box mounting bolts and remove the steering gear box assembly and the mounting rubber.

 **CAUTION**

*When removing the gear box, pull it out carefully and slowly to avoid damaging the boots.*

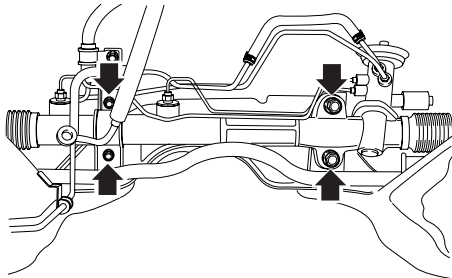

APCD020F

10. Remove the stabilizer bar.

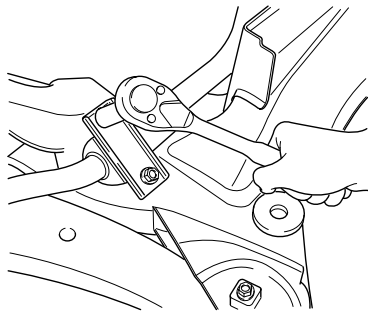

APCD037B

**DISASSEMBLY** EB69CEAD

1. Remove the tie rod end from the tie rod.

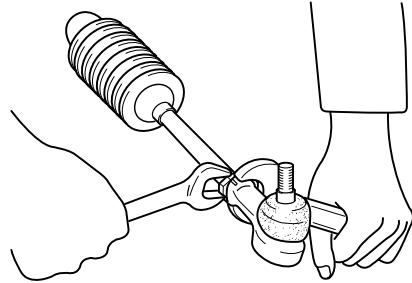

APCD025A

2. Remove the dust cover from the ball joint.

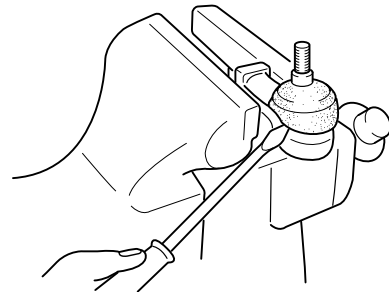

APCD025B

3. Remove the bellows band.

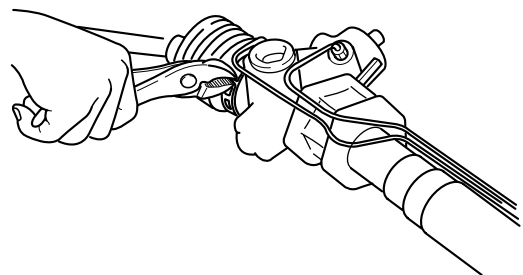

APCD025C

4. Remove the bellows clip.
5. Pull the bellows out toward the tie rod.

 **NOTE**

*Check for rust on the rack when the bellows are replaced.*

6. Remove the feed tube from the gear housing.

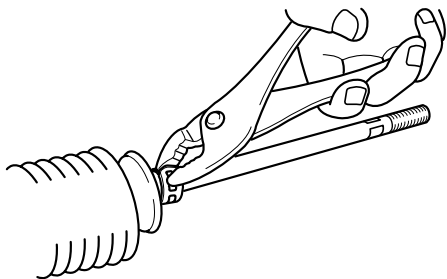

APCD025D

10. Remove the yoke plug lock nut.

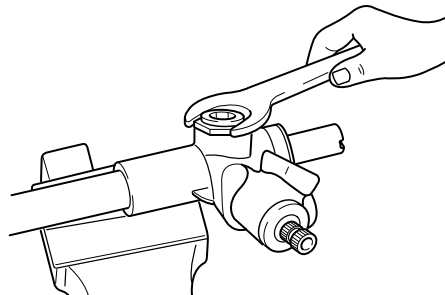

APCD025G

7. While moving the rack slowly, drain the fluid from the gear housing.

8. Remove the tab washer which fixes the tie rod and rack with a chisel.

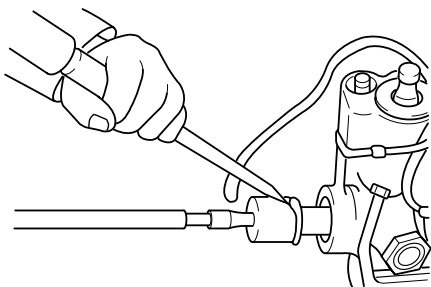

APCD025E

11. Using the special tool (09565-31300), remove the yoke plug.

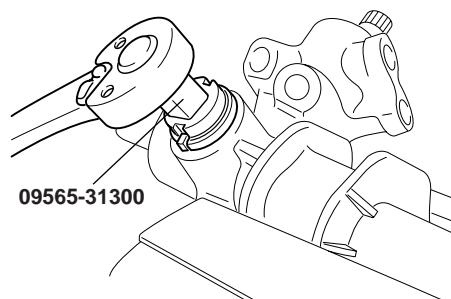

APCD025H

9. Remove the tie rod from the rack.



**CAUTION**

**Remove the tie rod from the rack, taking care not to twist the rack.**

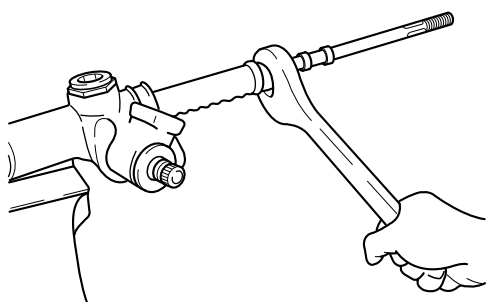

APCD025F

12. Remove the rack support spring, yoke support and bushing from the gear box.

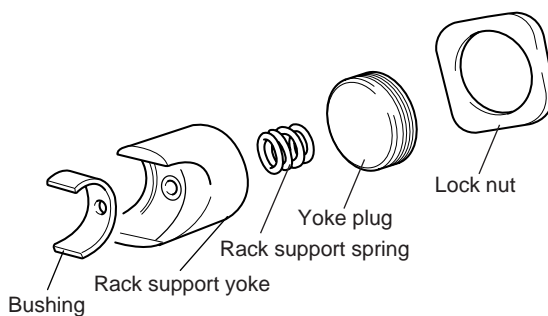

LPCD025I

13. Remove the end plug self-locking nut.

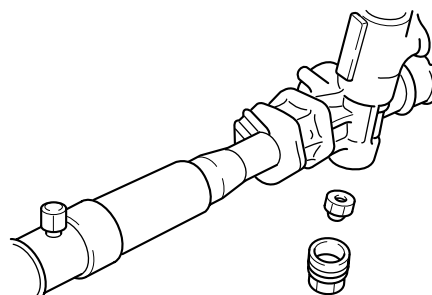

APCD025J

14. Detach the dust seal.
15. Remove the snap ring with snap ring pliers.
16. Remove the pinion and valve assembly and the oil seal (Upper) using a soft hammer.

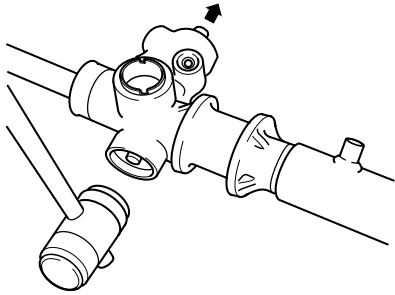

APCD025K

19. Remove the rack stopper, rack bushing and rack from the gear housing by moving them toward the piston side.

 **CAUTION**

*When the rack has been removed, be sure to replace the housing side oil seal with a new one.*

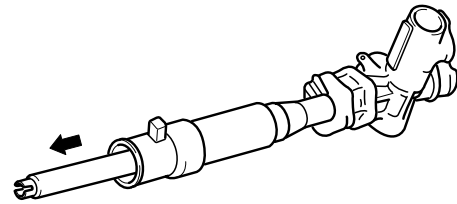

APCD025N

17. Turn the rack stopper clockwise until the end of the clip comes out of the slot in the gear housing.

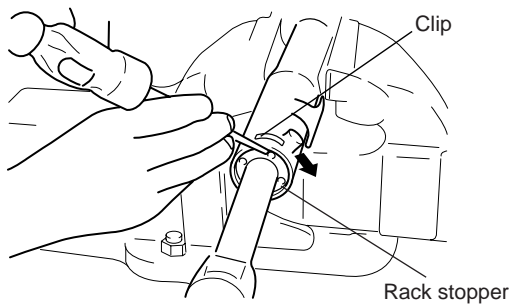

LPCD025L

20. Remove the O-ring from the rack bushing.

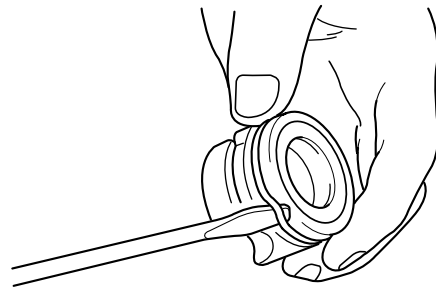

APCD025O

18. When the end of the clip comes out from the notched hole of the housing rack cylinder, turn the rack stopper counter clockwise and remove the clip.

 **CAUTION**

*Do not damage the rack when disassemble.*

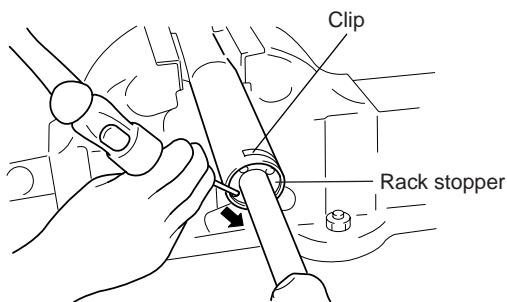

LPCD025M

21. Remove the oil seal from the rack bushing.

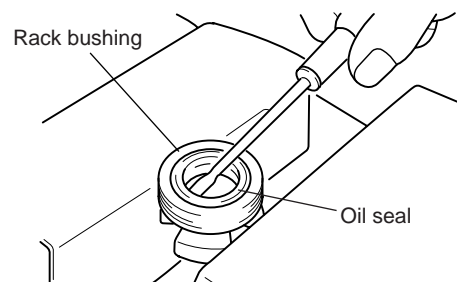

LPCD025P

22. Remove out the ball bearing from the gear housing using special tool (09517-21400) and hammer.

**CAUTION**

**Do not damage the pinion valve cylinder inside of the gear housing.**

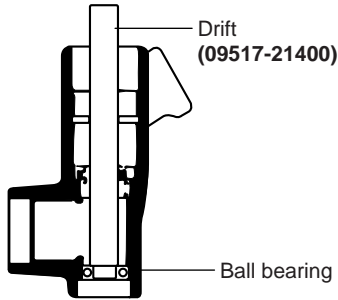

LPCD025Q

23. Remove out the needle bearing and oil seal.

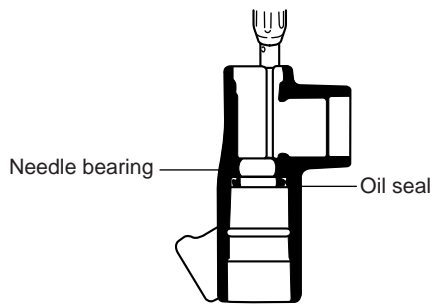

LPCD025R

24. Use the special tools (09573-33100) to remove the back washer and oil seal from the gear housing.

**CAUTION**

**Do not damage the rack cylinder inside of the gear housing.**

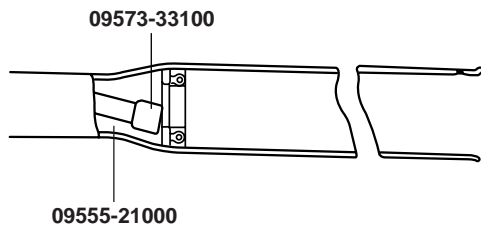

APCD025S

**INSPECTION** EA1C513F

1. Rack

- 1) Check for rack tooth face damage or wear
- 2) Check for oil seal contact surface damage or wear
- 3) Check for bending or twisting of rack
- 4) Check for oil seal ring damage or wear
- 5) Check for oil seal damage or wear

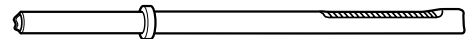

APCD030A

2. Pinion valve

- 1) Check for pinion gear tooth face damage or wear
- 2) Check for oil seal contact surface damage
- 3) Check for seal ring damage or wear
- 4) Check for oil seal damage or wear

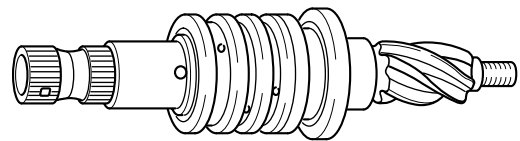

APCD030B

3. Bearing

- 1) Check for seizure or abnormal noise during bearing rotation
- 2) Check for excessive play
- 3) Check for missing needle bearing rollers

4. Others
  - 1) Check for damage of the gear housing cylinder bore
  - 2) Check for boot damage, cracking or ageing

**REASSEMBLY** E2CCAC9E

1. Apply the specified fluid to the entire surface of the oil seal and gear housing.

---

Recommended fluid  
Power steering fluid (PSF-III)

---

2. Using the special tools (09555-21000, 09573-21000, 09573-33000, 09573-33100), install the backup washer and oil seal to the specified position in the gear housing.
3. Apply the specified grease to the entire surface of the needle bearing.

---

Recommended grease  
Multipurpose grease SAE J310a, NLGI No. 2

---

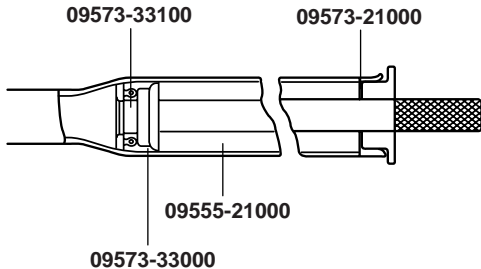

APCD035A

4. Install the needle bearing in the gear housing using the special tool (09222-21100).

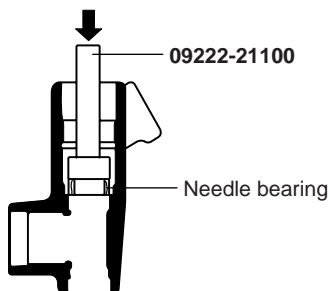

LPCD035B

5. Set the scribed side of the oil seal (inner) in the special tool (09431-11000) and install in the gear housing.

 **CAUTION**

- Note the direction of the oil seal.
- Use a new oil seal.

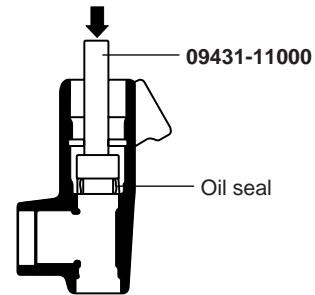

LPCD035C

6. Apply the specified fluid to the entire surface of the rack bushing oil seal.

---

Recommended fluid  
Power steering fluid (PSF-III)

---

7. Install the oil seal on the rack bushing.
8. Apply the specified fluid to the entire surface of the O-ring and install to the rack bushing using the special tool (09431-11000).

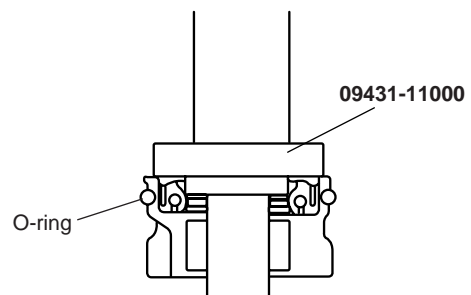

LPCD035D

**MECHANICAL POWER STEERING SYSTEM**

9. Apply the specified grease to the rack teeth.

Recommended grease  
Multipurpose grease SAE J310a, NLGI grade #2 EP

**CAUTION**

**Do not plug the vent hole in the rack with grease.**

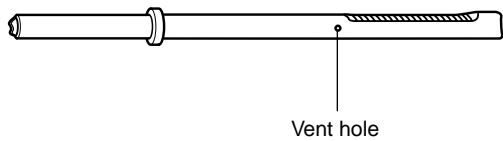

LPCD035E

10. Insert the rack into the gear housing. Install the rack bushing and rack stopper.

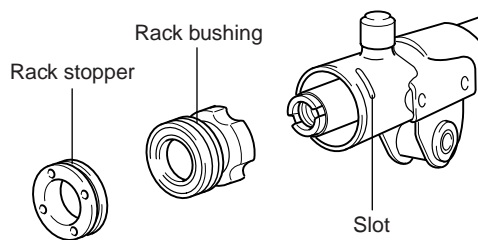

LPCD035F

11. Push in the rack stopper until the clip groove of the rack stopper is aligned with the notched hole of the rack housing and then install the clip while turning the rack stopper.

**CAUTION**

**The clip end should not be visible through the notched hole of the rack housing.**

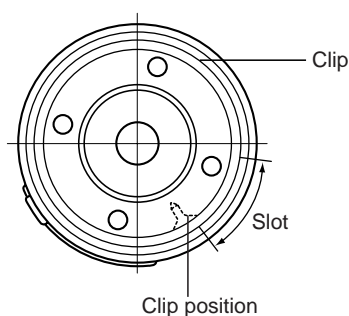

LPCD035G

12. Apply the specified fluid and grease to the pinion valve assembly and install to the gear housing assembly.

Recommended fluid  
Power steering fluid (PSF-III)  
Recommended grease  
Multipurpose grease SAE J310a, NLGI No.2

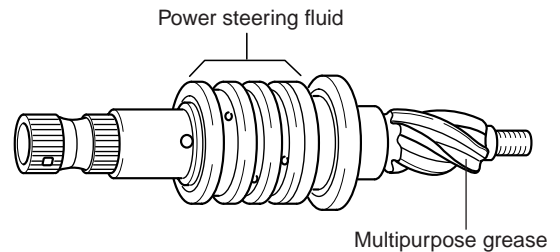

LPCD035H

13. Install the ball bearing using the special tool (09222-21100).

14. Install the pinion and valve assembly to the valve housing.

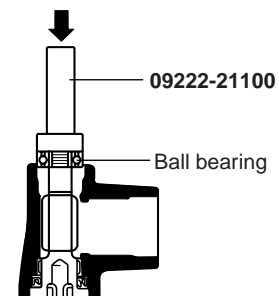

LPCD035I

15. Install the oil seal using the special tool (09432-21601).

16. Install the snap ring with snap ring pliers.

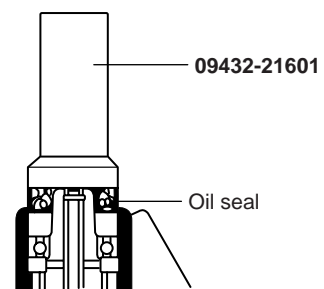

LPCD035J

17. With the pinion turned all the way clockwise, tighten the self-locking nut.

 **CAUTION**

*Always replace the self-locking nut with a new one.*

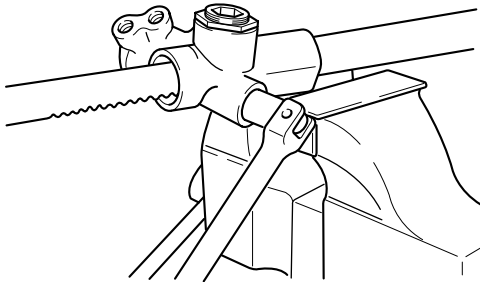

APCD035K

18. Apply semi-drying sealant to the threaded section of the end plug and tighten to the specified torque.

---

Tightening torque  
49-68.6 N·m (5-7 kg·m, 36.2-50.6 lb·ft)

---

19. Stake the end plug at two points on its circumference with a punch.

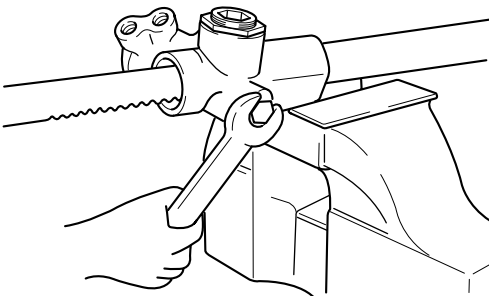

APCD035L

20. Install the tab washer and then the tie rod and hammer the tab washer end at two points to the tie rod.

 **CAUTION**

- **Align the tab washer pawls with the rack grooves.**
- **Use a new tab washer.**

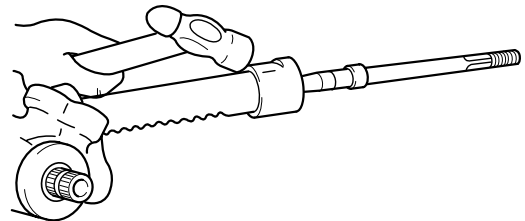

APCD035M

21. Install the bushing, rack support, yoke support spring and rack plug in the order shown. Apply semi-drying sealant to the threaded section of the yoke plug support cover before installation.

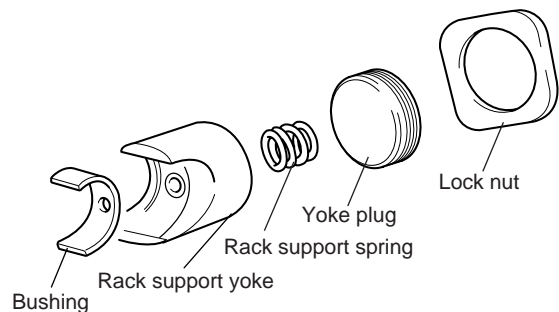

LPCD025I

22. With the rack placed at the center position, attach the yoke plug to the gear housing. Tighten the yoke plug within the range of 19.6-24.5 N·m (2.0-2.5 kg·m, 14.5-18.1 lb·ft), using the special tool. Loosen the yoke plug for approximately 20° and tighten the locking nut to the standard valve.

---

Standard valve  
Total pinion torque :  
49-68.6 N·m (5-7 kg·m, 38.2-50.6 lb·ft)

---

23. After adjusting, install the yoke plug with lock nut.

 **NOTE**

*When it cannot be adjusted within the specified return angle, check rack support plug components or replace.*

**MECHANICAL POWER STEERING SYSTEM**

**ST -25**

24. Tighten the feed tube to the specified torque and install the mounting rubber with adhesive.

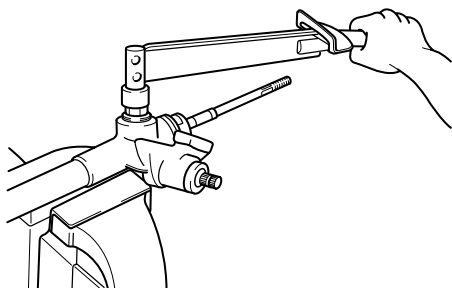

APCD0350

25. Apply the specified grease to the bellows mounting position (fitting groove) of the tie rod.

---

Recommended grease  
Multipurpose grease SAE J310a, NLGI No.2

---

26. Install the new attaching band to the bellows.

**CAUTION**

*Whenever the bellows are installed, a new band must be used.*

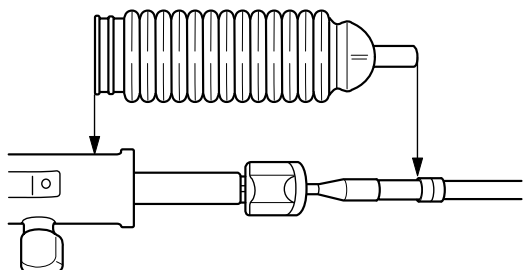

APCD035P

27. Install the bellows in, taking care not to twist it.

28. Fill the dust cover inner side and lip with the specified multipurpose grease, and place the dust cover in position with the clip ring attached in the groove of the tie rod end.

---

Recommended grease  
Multipurpose grease SAE J310a, NLGI No.2

---

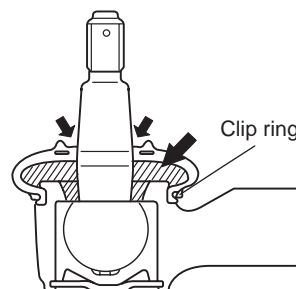

LPCD035Q

29. Install the tie rods so that the length of the left and right tie rods equals the standard value.

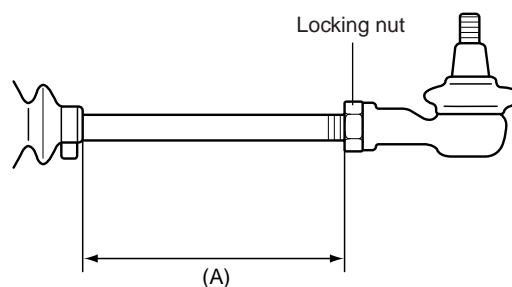

LPCD035R

---

(A) Tie rod free length :  $60.2 \pm 1\text{mm}$

---

**INSTALLATION** E8501DE8

1. When installing the mounting rubber, align the projection of the mounting rubber with the indentation in the cross member to install the gear box.
2. Confirm that there is no oil leak.
3. Confirm that the steering wheel rotates smoothly when it is turned.
4. Adjust the toe-in.
5. Install the parts by reference to torque specifications.

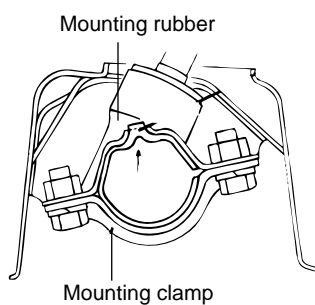

LPCD035S

POWER STEERING HOSES

COMPONENTS E42AFF1B

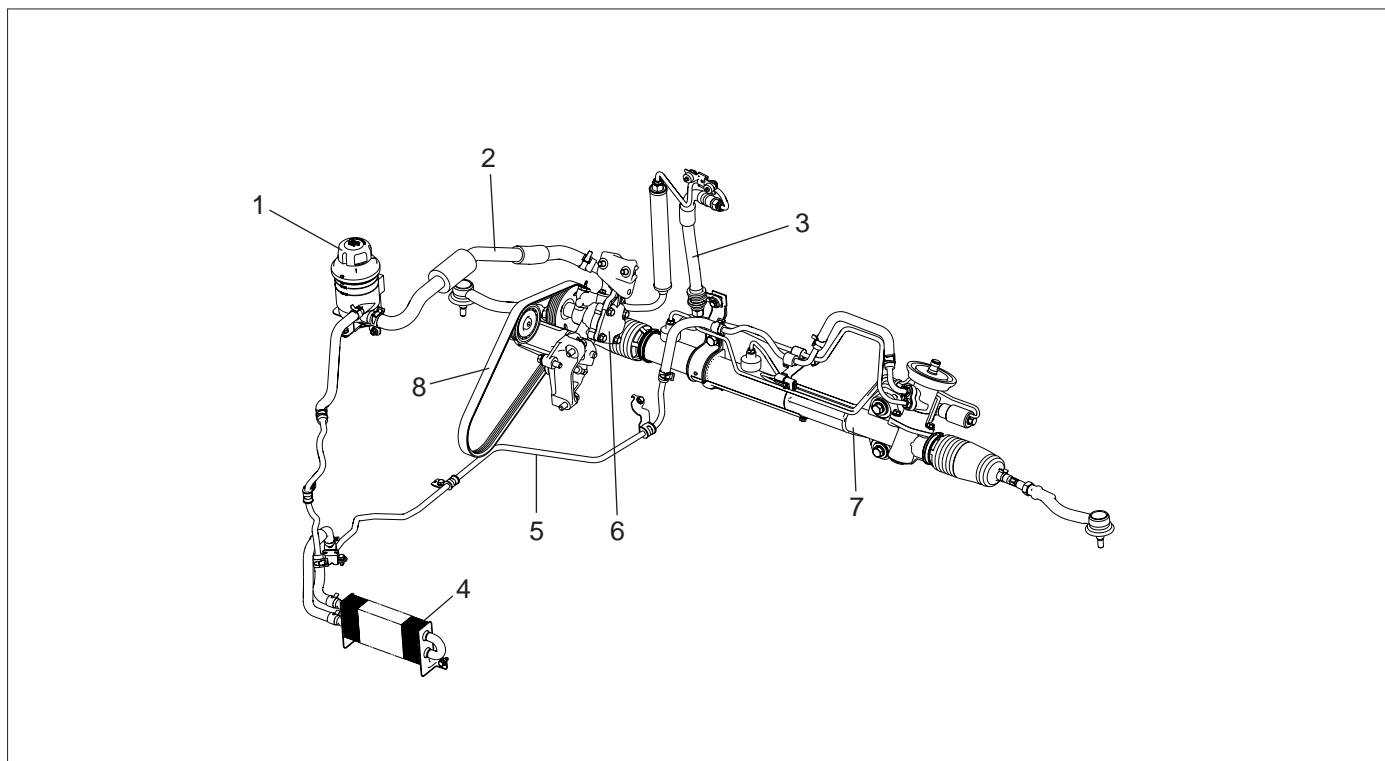

- |                              |                |
|------------------------------|----------------|
| 1. Oil reservoir             | 5. Return tube |
| 2. Suction hose              | 6. Oil pump    |
| 3. Pressure hose             | 7. Gear box    |
| 4. Power steering oil cooler | 8. Drive belt  |

LPCD040A

REMOVAL EBEBABE4

1. Drain the power steering fluid.
2. Disconnect the return hose and the suction hose from the oil reservoir.
3. Remove the flare nut of pressure hose.
4. Remove the return tube and rubber hose together with the flare nut and O-ring.
5. Remove the cooler tube.

# POWER STEERING OIL PUMP

## COMPONENTS EDBFDD57

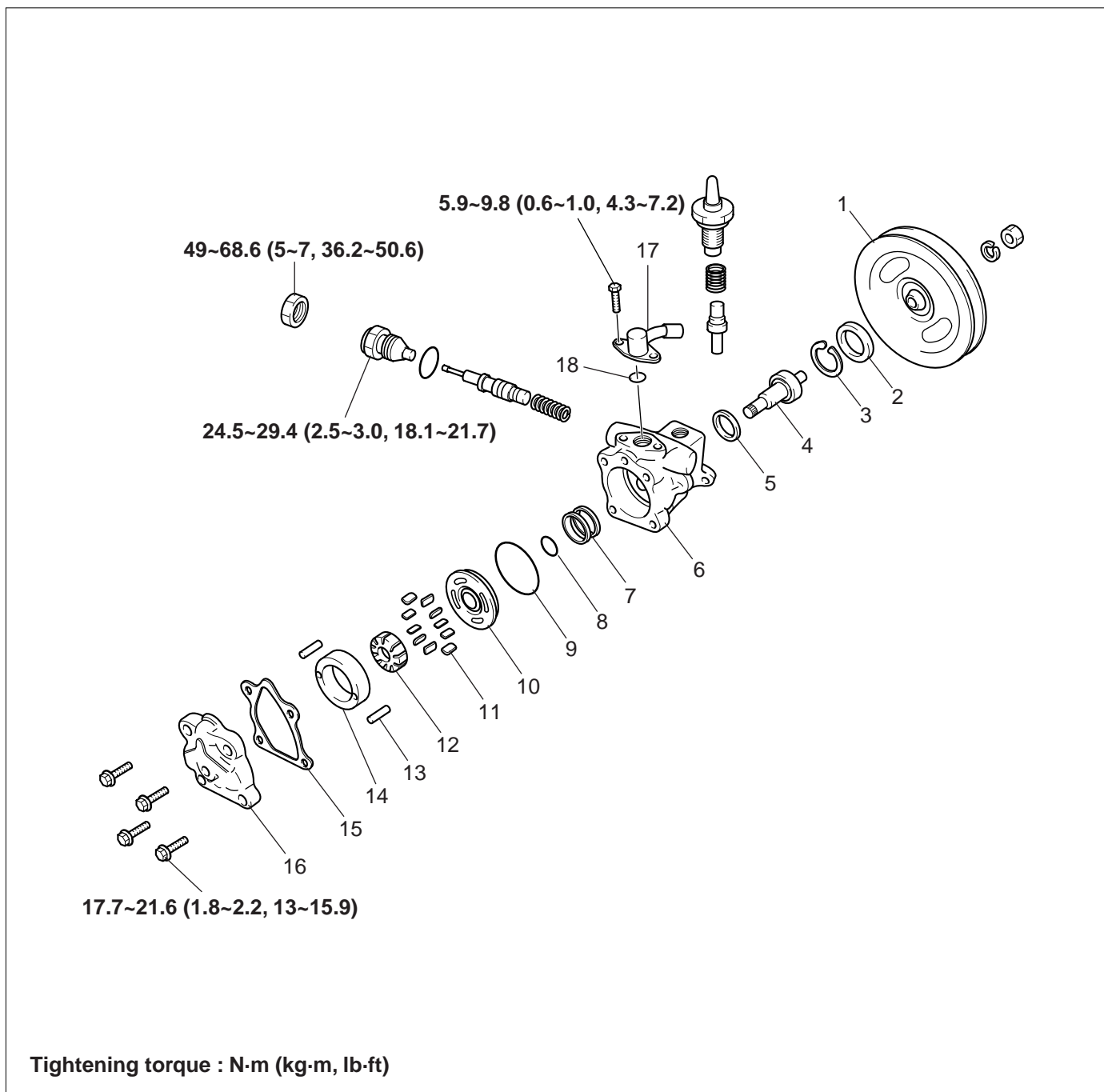

- |                          |                      |                  |
|--------------------------|----------------------|------------------|
| 1. Pulley                | 7. Spring            | 13. Pin          |
| 2. Dust space            | 8. O-ring (inner)    | 14. Cam ring     |
| 3. Snap ring             | 9. O-ring (outer)    | 15. Gasket       |
| 4. Bearing mounting      | 10. Front side plate | 16. Rear cover   |
| 5. Oil seal pulley shaft | 11. Vane             | 17. Suction pipe |
| 6. Front housing         | 12. Rotor            | 18. O-ring       |

LPCD045A

## MECHANICAL POWER STEERING SYSTEM

ST -29

### REMOVAL E2F89566

1. Remove the pressure hose from the oil pump.

#### NOTE

When assembling, use a new O-ring.

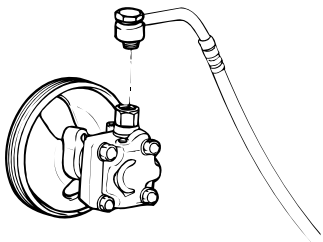

APCD050A

2. Disconnect the suction hose from the suction connector and drain the fluid into a container.

#### CAUTION

When removing the suction hose, cover the generator with vinyl not to be damaged by the oil inflowing.

3. Remove the drive belt.

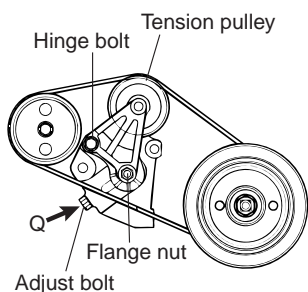

LPCD004I

4. Loosen the tensioner adjusting bolt to remove the drive belt.

5. Remove the oil pump mounting bolts and disconnect the pressure switch connector.

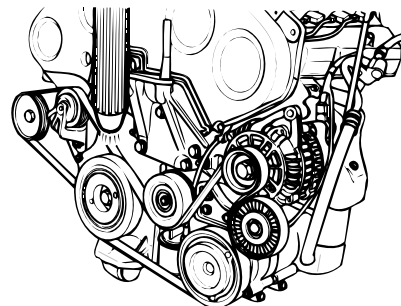

LPCD050C

### DISASSEMBLY ED2F3CE5

1. Remove the suction pipe and the O-ring from the oil pump.

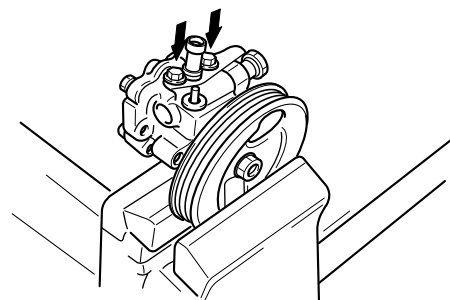

APCD055A

2. Remove the rear cover with the gasket.
3. Remove the cam ring.
4. Remove the rotor and vanes.
5. Remove the front side plate.

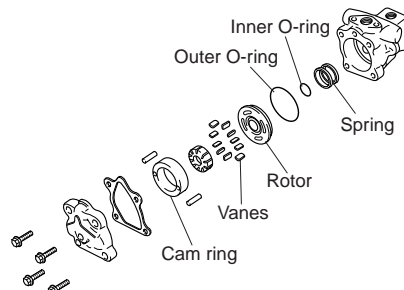

LPCD055B

6. Remove the inner and outer O-ring.
7. Remove the spring.

**NOTE**

When assembling, use a new gasket and O-ring.

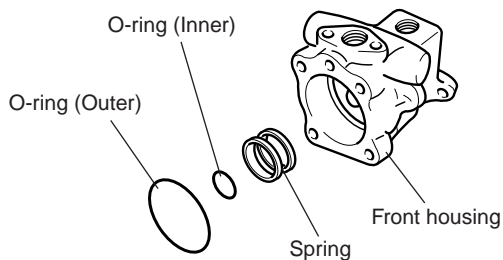

LPCD055C

8. Remove the oil seal.
9. Pull off the pulley shaft and bearing by using a plastic hammer.

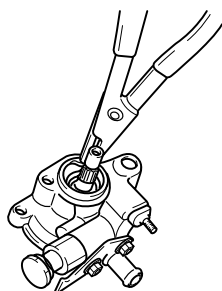

APCD055E

10. Remove the oil seal from the oil pump body.

**NOTE**

When assembling, use a new oil seal.

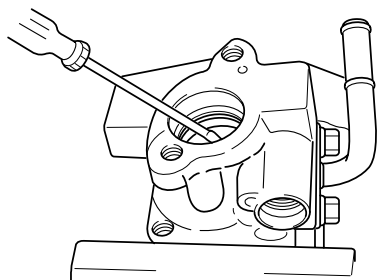

APCD055F

11. Remove the guide bracket and nut.

12. Remove the connector from the oil pump body, and then remove the flow control valve and flow control spring.
13. Remove the O-ring from the connector.

**CAUTION**

Do not disassemble the flow control valve.

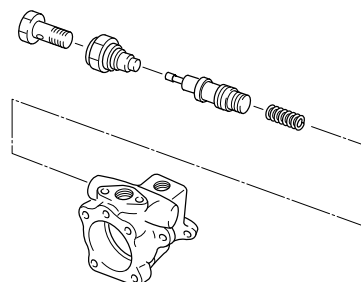

APCD055G

14. Remove the oil pump switch.
15. Take out the spring and the spool.
16. Remove the O-ring from the oil pump switch.

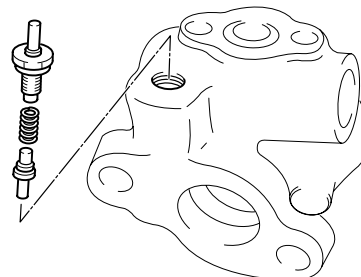

APCD055H

**INSPECTION**

E4967CFF

1. Clean all disassembled parts with a suitable cleaning solvent.
2. If any inside parts of the oil pump have been damaged, replace the pump as an assembly.
3. If the pulley is cracked or deformed, replace it.
4. If oil leaks around the pulley shaft oil seal, replace the oil seal.
5. If the serrations of the pulley or pulley shaft are deformed or worn out, replace them.

REASSEMBLY EB0A89DE

1. Install the oil pump switch.
2. Install the flow control valve spring, valve and connector in the pump body.

 **NOTE**

Apply a thin coat of power steering fluid to all parts including the oil seal and O-ring.

3. Install the guide bracket and nut.
4. Using special tool (09222-32100), install the oil seal into the pump body.

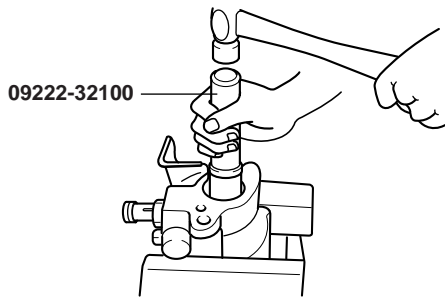

APCD065A

5. Gently insert the shaft assembly and install the snap ring.
6. Install the pump pulley and woodruff key in place.

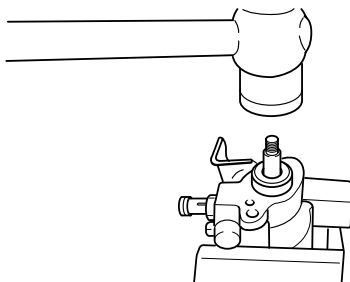

APCD065B

7. Install the spring and the inner and outer O-rings.
8. Install the front side plate.

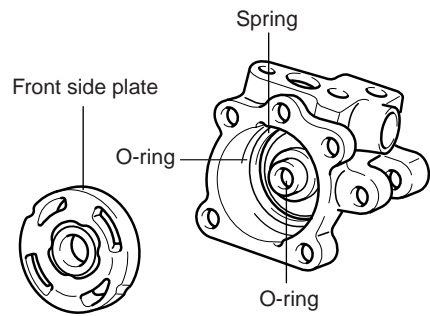

LPCD065C

9. Insert the pins into the pin grooves of the front housing, and then install the cam ring, paying attention to its direction.

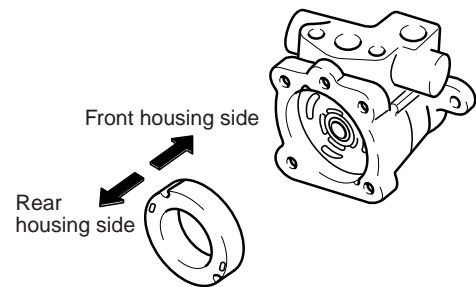

LPCD065D

10. Install the rotor with its punch marked side facing to-wards the front side plate.
11. Install the vane plates with the round end facing outward.

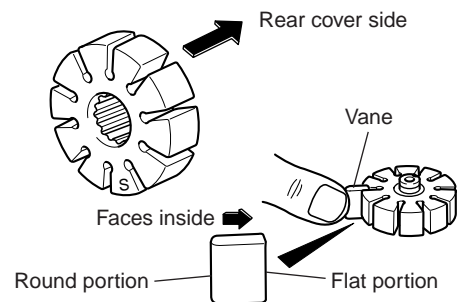

LPCD065E

12. Install the gasket and rear cover.
13. Tighten the suction connector.

**INSTALLATION** EEF4FF5D

1. Install the oil pump to the oil pump bracket.
2. Install the suction hose.
3. Install the ribbed V-belt and adjust its tension.
4. Connect the pressure hose to the oil pump, and the suction hose to the oil reservoir.



**NOTE**

*Install the hoses so that they are not twisted and they do not come in contact with any other parts.*

5. Replenish the reservoir.

---

Recommended fluid : Power steering fluid (PSF-III)

---

6. Bleed the system.
7. Check the oil pump pressure.
8. Install parts by referring to the torque specification.

## EPS (ELECTRONIC POWER STEERING) SYSTEM

### ELECTRONIC POWER STEERING SYSTEM

In addition, it has a solenoid valve on power steering gear box, and a control unit underneath the audio of the center facia. To control the oil flow of steering gear box, a solenoid is provided and it functions by the current from control module which receives signals from VSS (Vehicle Speed Sensor) and TPS.

#### GENERAL EF8B8742

The electronic power steering (EPS) system includes the same components of conventional power steering system.

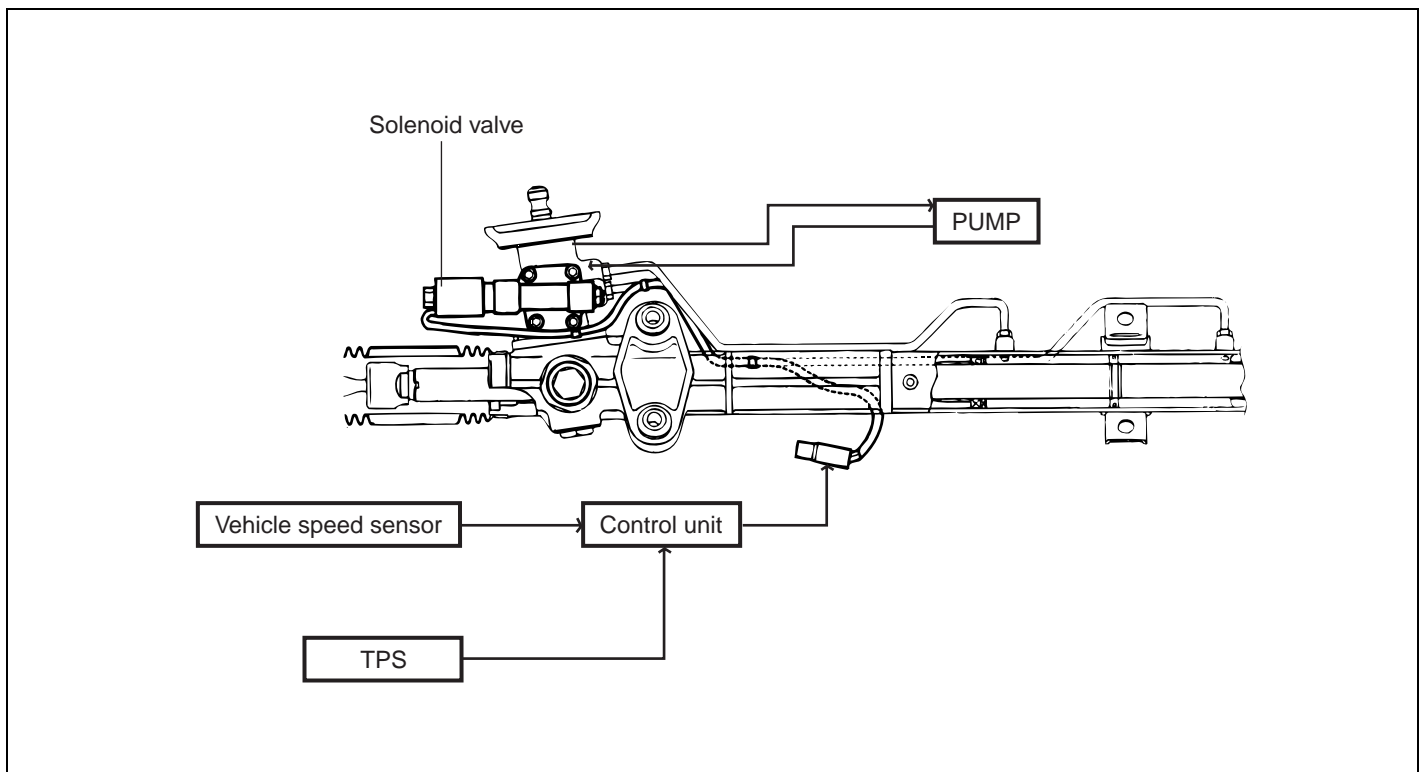

LPCD070A

EPS performs the conventional power steering function in case a failure has occurred in the system. EPS electronically controls the current to the solenoid of by-pass valve by inputting sensor's signals to control the hydraulic amount in cylinder chamber and thereby varying the steering effort versus the hydraulic pressure according to vehicle speed.

**REMOVAL AND INSTALLATION** EAB8DBD6

The removal and installation procedure is the same as that of conventional power steering system except for the solenoid valve components and EPS control module. Refer to the following figures.

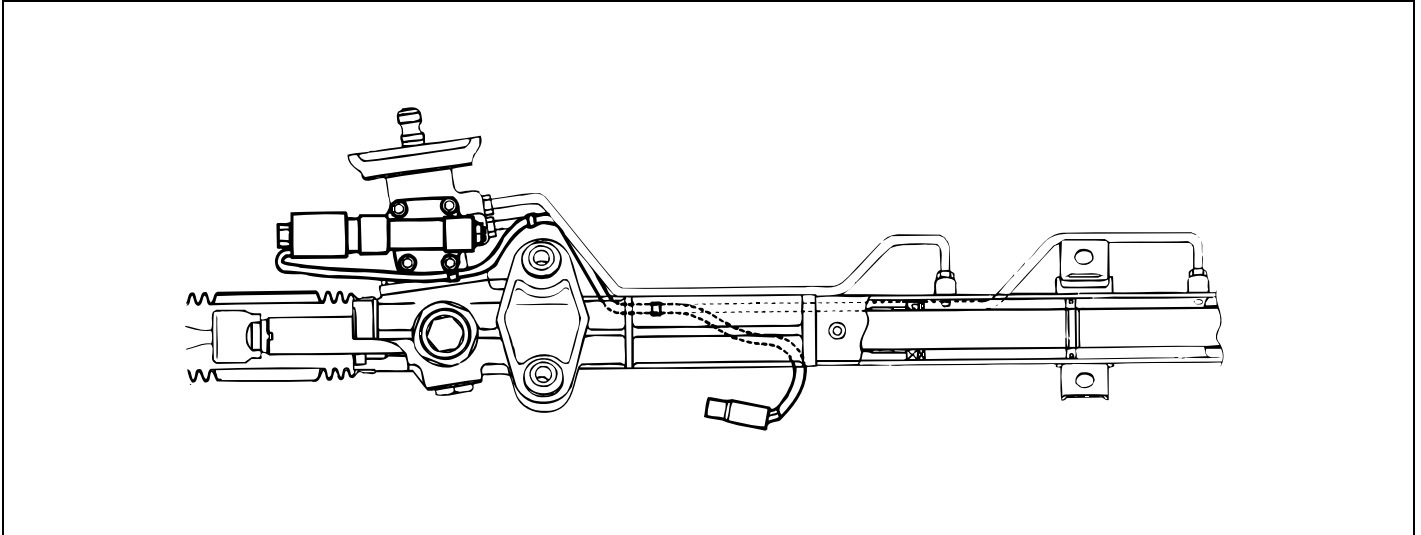

APCD085A

**ELECTRONIC POWER STEERING  
CONTROL MODULE** E105293C

The EPSCM is installed right of the passenger airbag module.

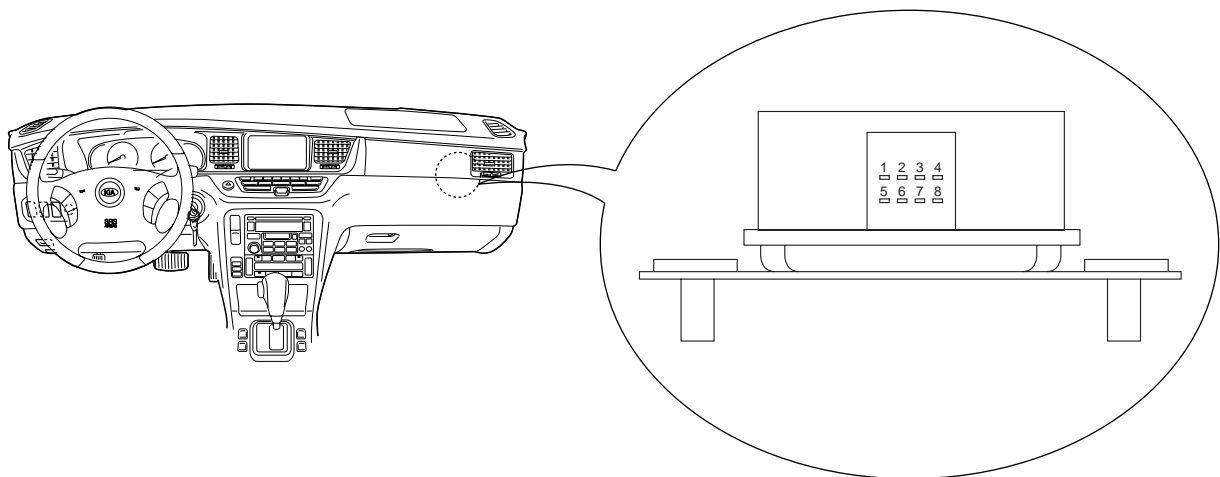

**PIN LAYOUT**

PIN NO.	DESCRIPTION
1	Solenoid
2	Solenoid
3	Sensor signal from vehicle speed sensor
4	IG2
5	Data link connector
6	Sensor signal from TPS
7	-
8	Ground

TROUBLESHOOTING

E4AB364E

DTC	Trouble	Condition	Measure time	Disposal	
C1101	Voltage over	VIG > 17V	1sec	Solenoid control stop	10V < VIG < 16V
C1102	Voltage under	VIG > 8V	1sec	Solenoid control stop	10V < VIG < 16V
C1212	Vehicle speed sensor	TPS > 30% over and vehicle speed 0km/h	60sec	Vehicle speed : 80km/h	Vehicle speed > 5km/h
C1604	ECU error	EEPROM Read/Write fail and PWM management error	1sec	Solenoid control stop	IGN ON/OFF
C2230	Solenoid current error	Measure voltage > 1.28A	1sec	Solenoid control stop	Power ON reset
		Solenoid disconnection	1sec		
		Target voltage-Measuer voltage > 0.2A and VIG > 13V	2sec		

 **NOTE**

For checking procedures for each problem, refer to the flow-chart type of troubleshooting guide on the following page.

**Trouble symptom 1**

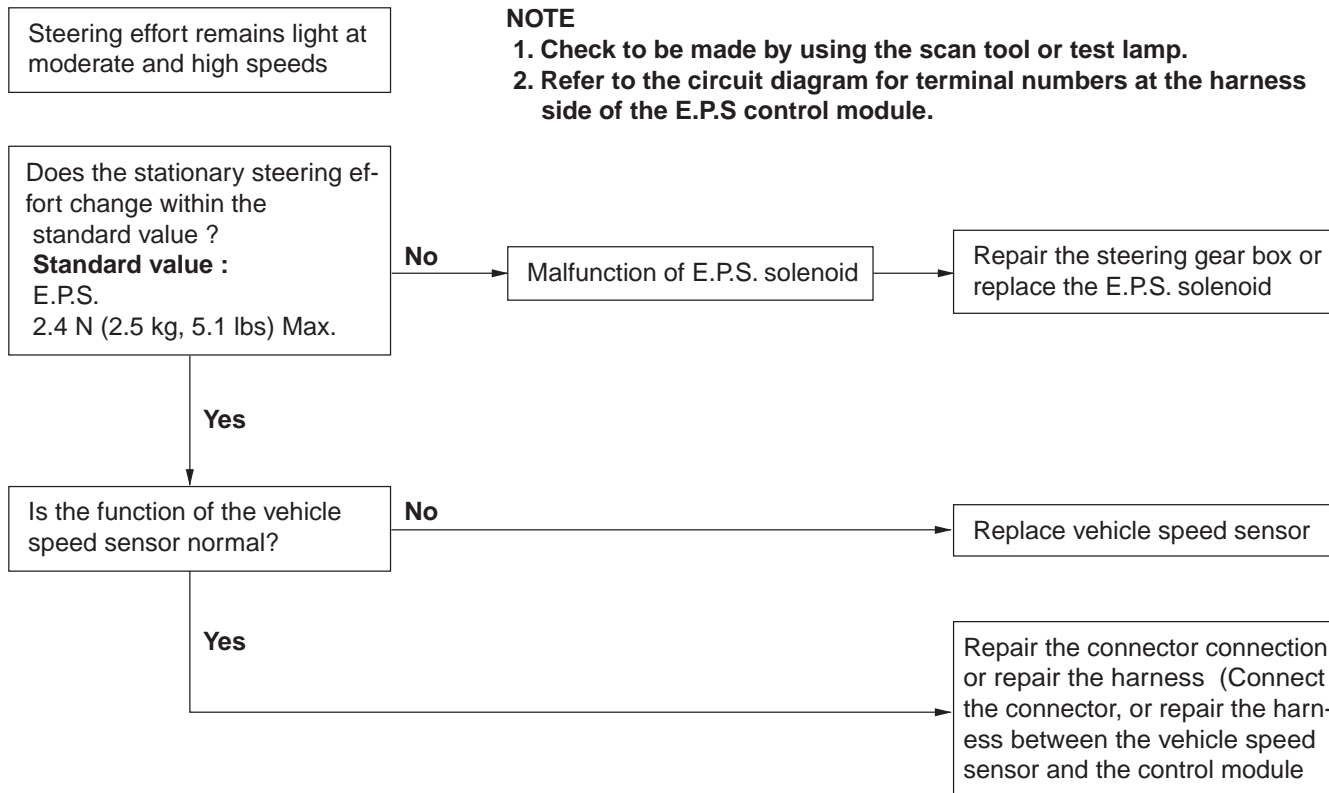

LPCD100A

Trouble symptom 2

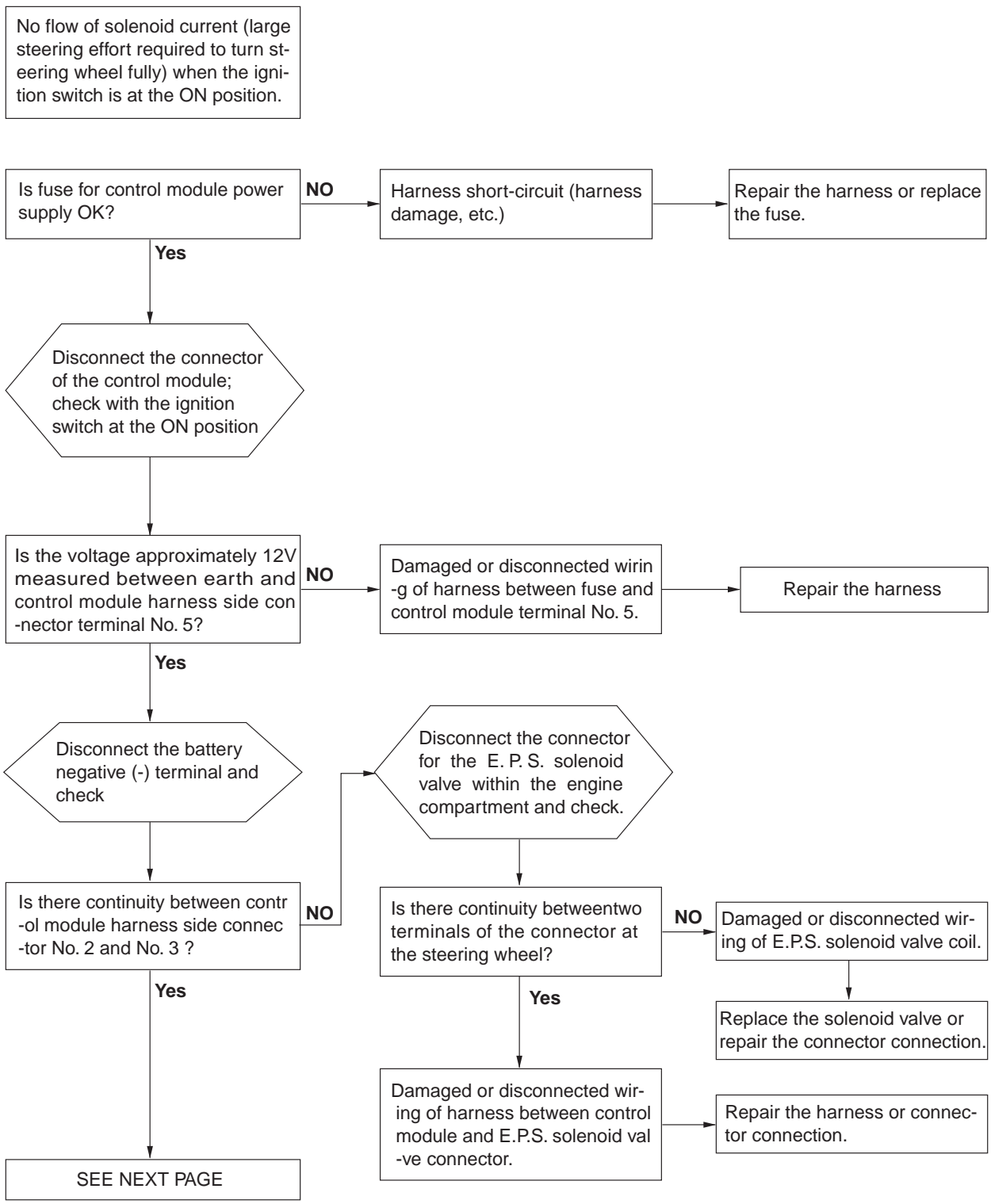

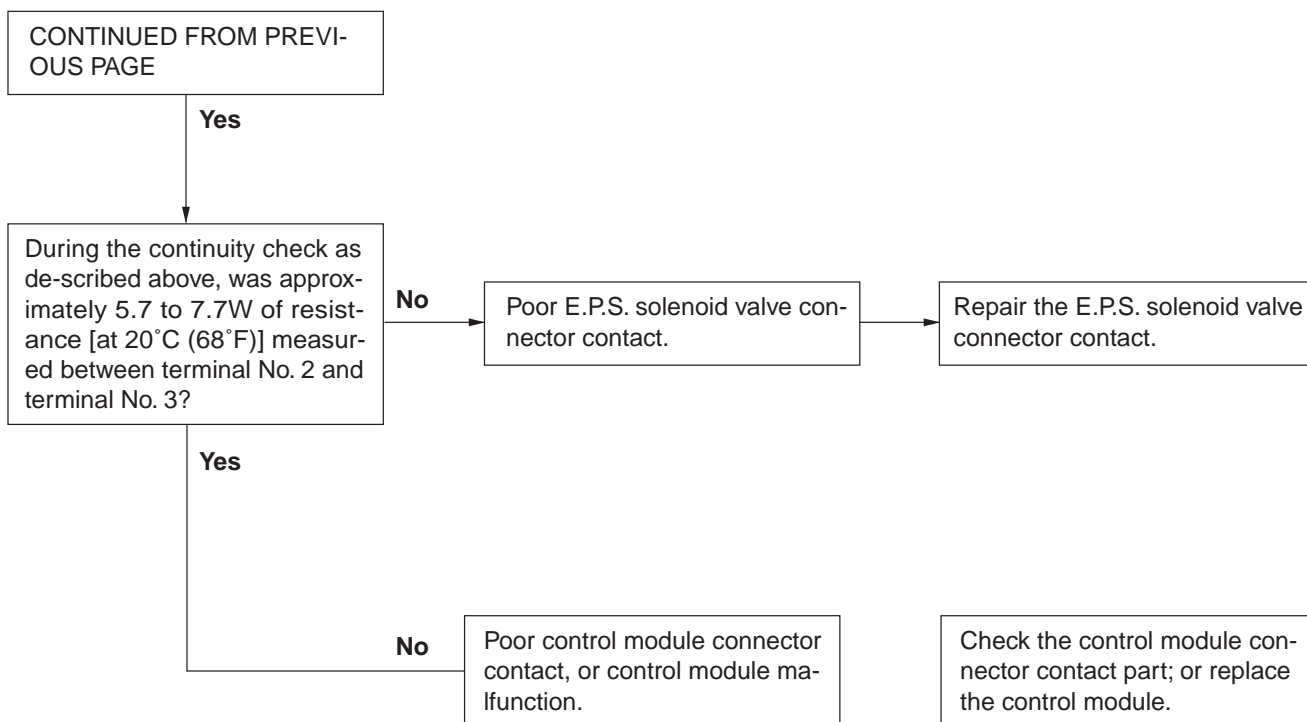

LPCD100C