

# Steering System

GENERAL .....	ST - 2
MECHANICAL POWER STEERING SYSTEM .....	ST -12

## GENERAL

### SPECIFICATIONS EA81FABD

Items	Specifications
Shaft and joint type	Cross joint, tilt column with pop-up weight
Steering gear type	Rack and pinion
Rack stroke	144 ± 1 mm (lock to lock : 3.15 turns)
Power steering pump type	Vane type
Oil pump displacement	9.6 cm <sup>3</sup> /rev. MAX. (0.59 in <sup>3</sup> /rev. MAX.)

### SERVICE STANDARD EB5F1D79

Items	Specifications
Steering wheel free play	0 ~ 30 mm (0 ~ 1.1 in.)
Steering angle Inner wheel Outer wheel	37° ± 0.5° 31.8°
Stationary steering effort	29N (3.0kg, 6.5lb) or less
Belt deflection [under 98N (10kg, 22lb) force]	6 ~ 9 mm (0.24 ~ 0.35 in.)
Oil pump relief pressure	8.3 ~ 8.8 MPa (85 ~ 90 kg/cm <sup>2</sup> , 1209 ~ 1280 psi)
Tie rod swing resistance	2 ~ 5 Nm (20 ~ 50 kg-cm, 1.4 ~ 3.6 lb-ft)
Tie rod end ball joint starting torque	0.5 ~ 2.5 Nm (5 ~ 25 kg-cm, 0.36 ~ 1.81 lb-ft)

### TIGHTENING TORQUE

Item	Nm	kg-cm	lb-ft
Steering wheel and shaft (with Airbag)	35~45	350~450	26~33
Steering column and shaft assembly mounting bracket	13~18	130~180	9~13
Steering shaft and joint	15~20	150~200	11~14
Joint to gear box	15~20	150~200	11~14
Gear box mounting bolt	60~80	600~800	43~58
Tie rod end lock nut	50~55	500~550	36~40
Tie rod end ball joint slotted nut	16~34	160~340	12~25
Yoke plug lock nut	50~70	500~700	36~51
Tie rod to rack	80~100	800~1000	58~72
Valve body housing to rack housing assembly	20~30	200~300	14~22
Pressure and return tube to gear box	12~18	120~180	9~13
Feed tube	10~16	100~160	7~12
Oil pump to mounting bracket	35~50	350~500	25~36
Oil pump bracket to engine	35~50	350~500	25~36
Pressure hose to oil pump	55~65	550~650	40~47
Oil reservoir mounting bolt	4~6	40~60	3~4

**GENERAL**

**ST -3**

**LUBRICANTS**

Item	Recommended lubricant	Quantity
Ball joint of tie rod end	SHOWA SUNLIGHT MB-2 OR equivalent	4g
Contact area of gear box bellows & tie rod	SILICON GREASE	As required
Power steering fluid	PSF-III	0.75~0.8 liter (0.79~0.84 qts.)

**SPECIAL TOOLS** ED961191

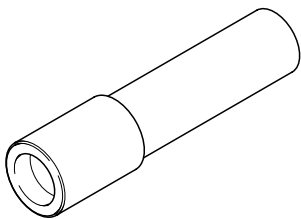
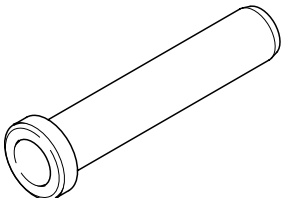
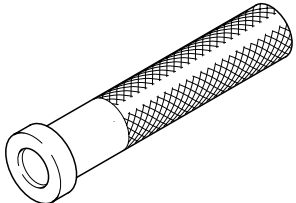
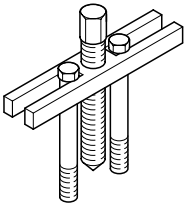
Tool (Number and name)	Illustration	Use
09222-32100 Valve stem oil seal installer	 HCT5602	Installing the pinion gear bearing
09432-21601 Bearing installer	 EPA9005D	Installing the pinion gear bearing
09434-14200 Counter shaft bearing installer	 EPKB040A	Installing the gear box oil seal.
09561-11002 Steering wheel puller	 HCT5607	Removing the steering wheel.

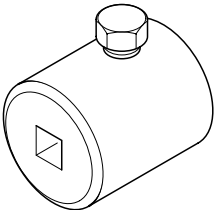
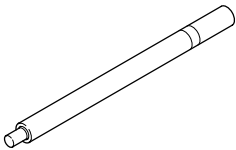
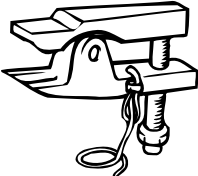
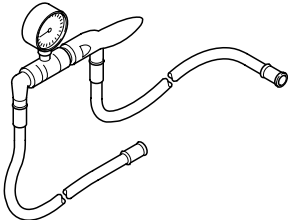
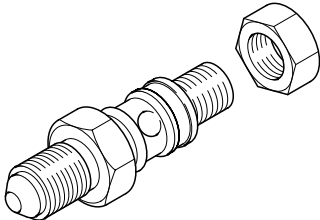
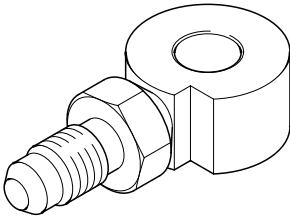
Tool (Number and name)	Illustration	Use
09565-11100 Preload socket	 EPA9005G	Measuring the pinion shaft preload.
09555-21000 Bar	 APGE001E	Removing & installing the oil seal of the rack housing.
09568-34000 Ball joint puller	 E6834000	Separating the tie rod end ball joint.
09572-21000 Oil pressure gauge	 EPA9005K	Measuring the power steering oil pressure (use with 09572-21200, 09572-22100)
09572-21200 Oil pressure gauge adapter	 EPA9005L	Measuring the power steering oil pressure (use with 09572-21000, 09572-22100)
09572-22100 Oil pressure gauge adapter	 EPA9005M	Measuring the power steering oil pressure (use with 09572-21000, 09572-21200)

**GENERAL**

**ST -5**

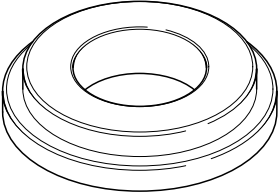
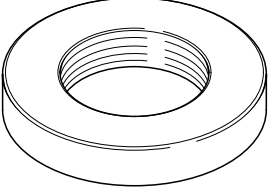
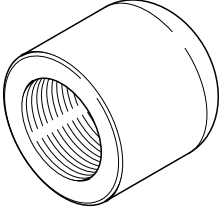
Tool (Number and name)	Illustration	Use
09573-21000 Oil seal installer gauge	 EPKB040C	Installing the oil seal of the rack housing
09573-21100 Oil seal installer	 EPKB040D	Installing the oil seal of the rack housing
09573-21200 Oil seal guide	 EPKB040E	Removing & installing the oil seal of the rack housing

**TROUBLESHOOTING**

E3FC9073

Symptom	Probable cause	Remedy
Excessive play in steering	Loose yoke plug	Retighten
	Loose steering gear mounting bolts	Retighten
	Loose or worn tie rod end	Retighten or replace as necessary
Steering wheel operation is not smooth (Insufficient power assist)	V-belt slippage	Readjust
	Damaged V-belt	Replace
	Low fluid level	Replenish
	Air in the fluid	Bleed air
	Twisted or damaged hoses	Correct the routing or replace
	Insufficient oil pump pressure	Repair or replace the oil pump
	Sticky flow control valve	Replace
	Excessive internal oil pump leakage	Replace the damaged parts
	Excessive oil leaks from rack and pinion in gear box	Replace the damaged parts
Distorted or damaged gear box or valve body seals	Replace	

Symptom	Probable cause	Remedy
Steering wheel does not return properly	Excessive turning resistance of tierod end	Replace
	Yoke plug excessively tight	Adjust
	Tie rod and/or ball joint cannot turn smoothly	Replace
	Loose mounting of gear box mounting bracket	Retighten
	Worn steering shaft joint and/or body grommet	Correct or replace
	Distorted rack	Replace
	Damaged pinion bearing	Replace
	Twisted or damaged hoses	Reposition or replace
	Damaged oil pressure control valve	Replace
	Damaged oil pump input shaft bearing	Replace
Noise	<b>Hissing Noise in Steering Gear</b> There is some noise with all power steering systems. One of the most common is a hissing sound when the steering wheel is turned and the car is not moving. This noise will be most evident when turning the wheel while the brakes are being applied. There is no relationship between this noise and steering performance. Do not replace the valve unless the "hissing" noise becomes extreme. A replaced valve will also make a slight noise, and is not always a solution for the condition	
Rattling or chucking noise in the rack and pinion	Interference with hoses from vehicle body	Reposition
	Loose gear box bracket	Retighten
	Loose tie rod end and/or ball joint	Retighten
	Worn tie rod and/or ball joint	Replace
Noise in the oil pump	Low fluid level	Replenish
	Air in the fluid	Bleed air
	Loose pump mounting bolts	Retighten

 **NOTE**

A slight "grinding noise" may be heard immediately after the engine is started in extremely cold weather conditions (below - 20°C). This is due to power steering fluid characteristics in extreme cold conditions and is not an indication of a malfunction.

**SERVICE ADJUSTMENT**

**PROCEDURE** E6CD5D8D

**CHECKING STEERING WHEEL FREE PLAY**

1. Start the engine with the steering wheel in the straight ahead position, apply a force of 5 N (1.1 lb) to the steering wheel in the peripheral direction.
2. Measure the play at the circumference of the steering wheel.

**Standard value**

Steering wheel free play : 0~30 mm (0~1.1 in)

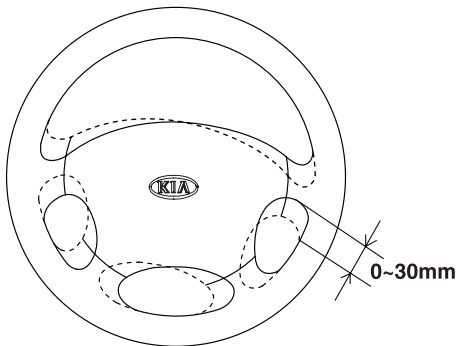

APGE001A

3. If the play exceeds the standard value, inspect the connection between the steering shaft and tie rod ends.

**CHECKING STEERING ANGLE**

1. Place the front wheel on a turning radius gauge and measure the steering angle.

**Standard value**

Wheel angle

Inner wheel :  $37^{\circ} \pm 0.5^{\circ}$

Outer wheel :  $31.8^{\circ}$

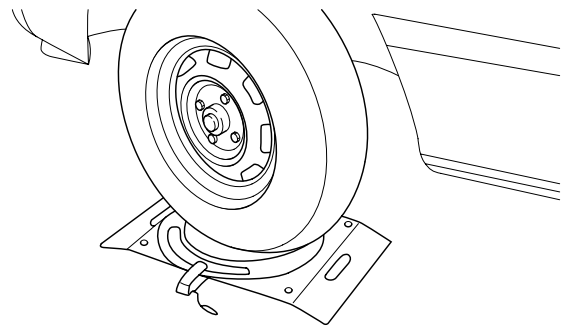

EPKE001A

2. If the measured value is not within the standard value, adjust the linkage.

**CHECKING THE TIE ROD END BALL JOINT STARTING TORQUE**

1. Disconnect the tie rod(A) and knuckle(B) by using the special tool (09568-34000).

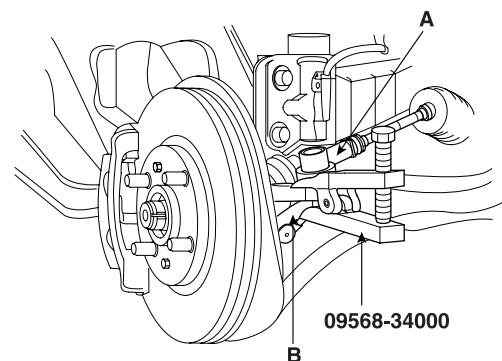

EPKE002A

2. Shake the ball joint stud several times to check for looseness.

**ST -8**

**STEERING SYSTEM**

3. Mount the nuts on the ball joint, and then measure the ball joint starting torque.

---

**Standard value**

0.5~2.5 Nm (5~25 kg·cm, 0.36~1.80 lb·ft)

---

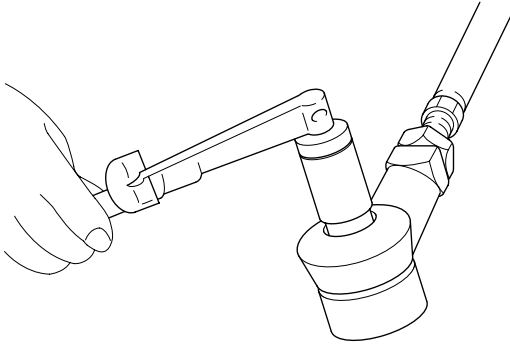

EPA9003A

4. If the starting torque exceeds the upper limit of the standard value, replace the tie rod end.
5. Even if the starting torque is below the lower limit of the standard value, check the play of the ball joint and replace if necessary.

**CHECKING STATIONARY STEERING EFFORT**

1. Place the vehicle on a level surface and place the steering wheel in the straight ahead position.
2. Increase the engine speed to  $1000 \pm 100$  rpm.

 **NOTE**

After checking, reset the engine speed to the standard value (idling speed).

3. Measure the turning force with a spring scale(A) by turning the steering wheel(B) clockwise and counter-clockwise one and a quarter turns.

---

**Standard value**

Stationary steering effort :  
29 N (3.0 kg, 6.5lbs) or less

---

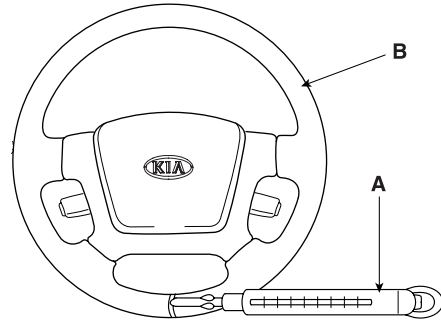

APGE001B

4. Check that there is no sudden change of force while turning the steering wheel.
5. If the stationary steering effort is excessive, check and adjust the following points.
  - 1) Damage or cracks on the dust cover of the lower arm ball joint and tie rod end.
  - 2) Pinion preload of the steering gear box and starting torque of the tie rod end ball joint.
  - 3) Starting torque of the ball joint.

**CHECKING STEERING WHEEL RETURN**

1. The force required to turn the steering wheel and the wheel return should be the same for both left and right in case of moderate or sharp turns.
2. When the steering wheel is turned 90° and held for a couple of seconds while the vehicle is being driven at 35kph, the steering wheel should return to within 20° from the neutral position when it is released.

**NOTE**

If the steering wheel is turned very quickly, steering may be momentarily difficult. This is not a malfunction because the oil pump output will be somewhat decreased.

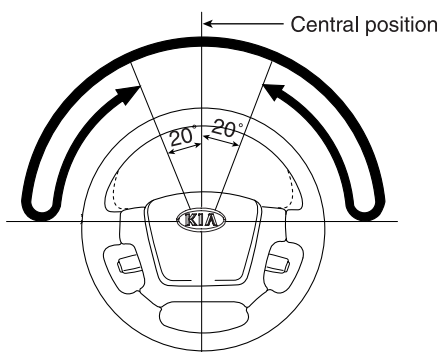

BPGE001A

**CHECKING POWER STEERING BELT TENSION**

1. Press the V belt, applying a pressure of 98N (10kg, 22lb) at the specified point and measure the deflection to confirm that it is within the standard value.

**Standard value**

V belt deflection : 6~9 mm (0.24 ~ 0.35 in)

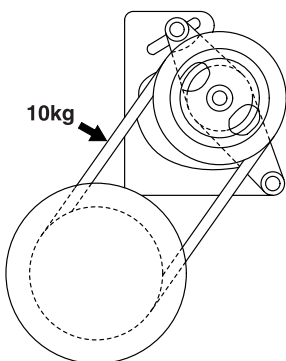

EPKE085A

2. If the belt deflection is beyond the standard value, adjust the belt tension as follows.

- 1) Loosen the bolt(A) adjusting the power steering V belt tension.

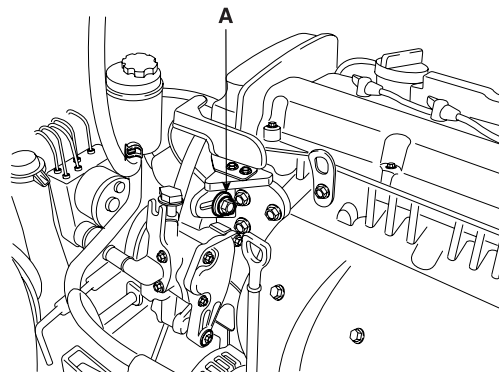

APGE011A

- 2) Put a bar(A) or equivalent, between the bracket(B) and the oil pump(C) and adjust the tension so that the belt deflection is within the standard value.

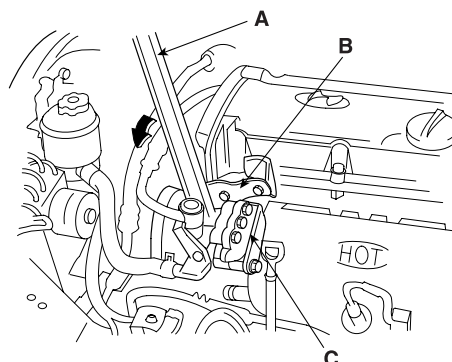

EPKE005A

- 3) Tighten the bolt adjusting the power steering V belt tension.
- 4) Check the belt deflection and adjust it again if necessary.

**CAUTION**

After turning the V belt in the normal rotation direction more than once, recheck the belt deflection.

**CHECKING POWER STEERING FLUID LEVEL**

1. Position the vehicle on a level surface.
2. Start the engine. With the vehicle kept stationary, turn the steering wheel several times continuously to raise the fluid temperature to 50 - 60°C(122 to 140°F).
3. With the engine at idle, turn the steering wheel fully clockwise and counterclockwise several times.
4. Make sure there is no foaming or cloudiness in the reservoir fluid.
5. Stop the engine to check for any difference in fluid level between a stationary and a running engine.

**NOTE**

1. If the fluid level varies 5 mm (0.2 in.) or more, bleed the system again.
2. If the fluid level suddenly rises after stopping the engine, further bleeding is required.
3. Incomplete bleeding will produce a chattering sound in the pump and noise in the flow control valve, and lead to decreased durability of the pump.

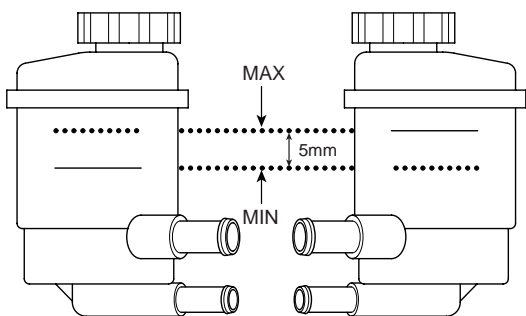

KPKA008A

**REPLACING POWER STEERING FLUID**

1. Jack up the front wheels of the car and support them with jackstands.
2. Disconnect the return hose from the oil reservoir and plug the oil reservoir.
3. Connect a hose to the disconnected return hose, and drain the oil into a container.
4. Disconnect the high tension cables and ignition coils. While operating the starter motor intermittently, turn the steering wheel all the way to the left and then to the right several times to drain the fluid.

5. Connect the return hose and fix it with a clip.
6. Fill the power steering fluid reservoir with the specified fluid.

---

PSF-III : 0.75~0.8 lit.

---

7. Start the engine. Check for fluid leaks from the hose, then stop the engine.
8. Pour the fluid into the bottom of the oil filter in the power steering fluid reservoir.
9. Bleed the air.

**AIR BLEEDING**

1. Fill the power steering fluid reservoir up to the "MAX" position with specified fluid.
2. Jack up the front wheels.
3. Disconnect the ignition coil high tension cable, and then, while operating the starter motor intermittently (for 15 to 20 seconds), turn the steering wheel all the way to the left and then to the right five or six times.

**NOTE**

1. When bleeding fluid, replenish with the fluid so that the level does not fall below the bottom of the filter.
2. If air bleeding is done while the vehicle is idling, the air will be broken up and absorbed into the fluid. Be sure to do the bleeding only while cranking.

4. Connect the high tension cable, and then start the engine (idling).
5. Turn the steering wheel to the left and then to the right, until there are no air bubbles in the oil reservoir.

**NOTE**

Do not hold the steering wheel turned all the way to either side for more than ten seconds.

6. Confirm that the fluid is not milky and that the level is between "MAX" and "MIN" mark on the reservoir.
7. Check that there is a little change in the fluid level when the steering wheel is turned left and right.

**NOTE**

1. If the fluid level varies 5mm (0.2 in.) or more, bleed the system again.
2. If the fluid level suddenly rises after stopping the engine, further bleeding is required.

3. Incomplete bleeding will produce a chattering sound in the pump and noise in the flow control valve, and lead to decreased durability of the pump.

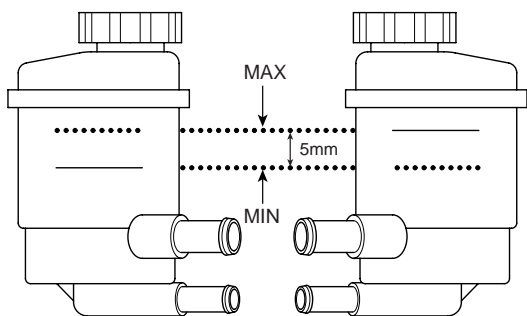

KPKA008A

4. Close the shut-off valve of the special tool and measure the fluid pressure to confirm that it is within the standard value range.

**Standard value**

Oil pump pressure

Relief pressure :

8.3~8.8 MPa (85~90 kg.cm<sup>2</sup>, 1209~1280 psi)

**CAUTION**

*Do not keep the shut-off valve on the pressure gauge closed for more than ten seconds.*

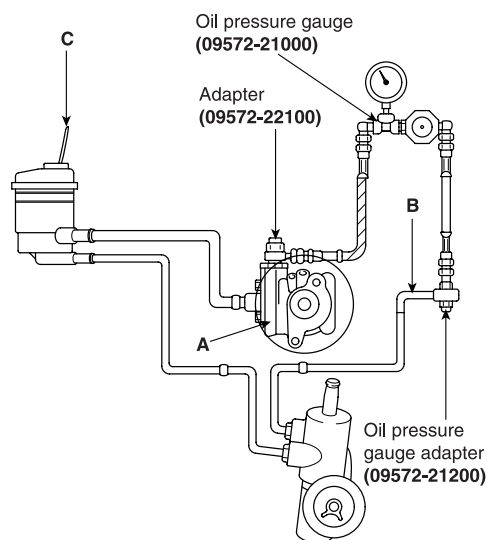

BPGE001B

**OIL PUMP PRESSURE TEST**

1. Disconnect the pressure hose(B) from the pump(A). Connect the special tool between the pump and the pressure hose as illustrated.

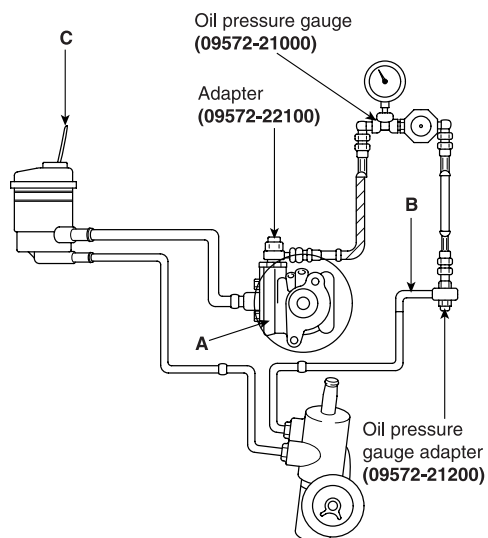

BPGE001B

5. Remove the special tools, and tighten the pressure hose(B) against the oil pump(A) using the specified torque.

**Tightening torque**

55~65 Nm (550~650 kg.cm, 40~47 lb.ft)

2. Bleed the air, and then start the engine and turn the steering wheel several times, measure the fluid temperature by Temperature gauge (C) so that the fluid temperature can rise to approximately 50°C (122°F).
3. Increase the engine speed to 1,000 rpm.

# MECHANICAL POWER STEERING SYSTEM

## STEERING COLUMN/SHAFT

### COMPONENTS E637E9C9

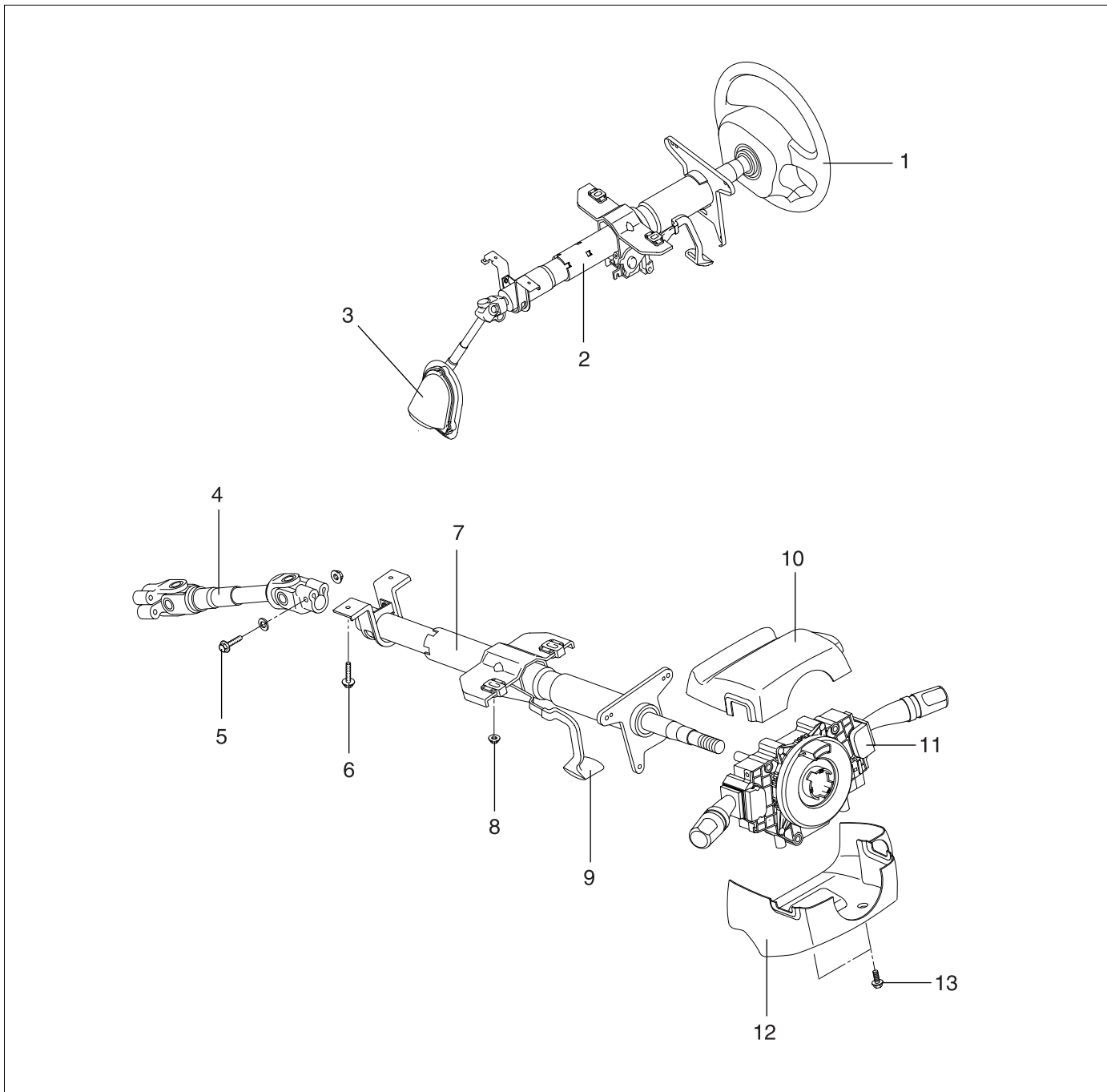

- |  |  |
|--|--|
| 1. Steering wheel                      | 8. Steering column shaft mounting nut          |
| 2. Steering column                     | 9. Tilt lever                                  |
| 3. Dust cover assembly                 | 10. Steering column upper shroud               |
| 4. Universal joint assembly            | 11. Multifunction switch                       |
| 5. Universal joint mounting bolt       | 12. Steering column lower shroud               |
| 6. Steering column shaft mounting bolt | 13. Steering column lower shroud mounting bolt |
| 7. Steering column shaft assembly      |  |

REMOVAL E6AF4F1D

1. Disconnect the negative (-) terminal(A) from the battery.

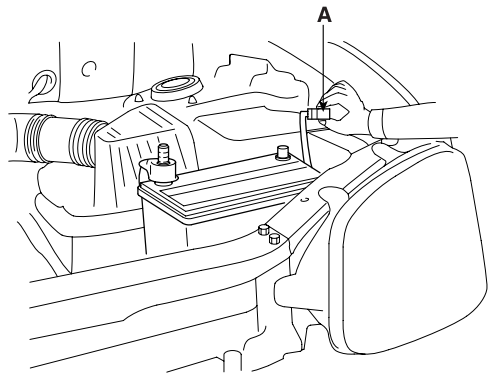

EPKE011A

2. Remove the bolts (A) in the illustration, and then remove the driver's airbag module(B).

**NOTE**

For the vehicles not equipped with SRS airbag, remove the horn cover assembly.

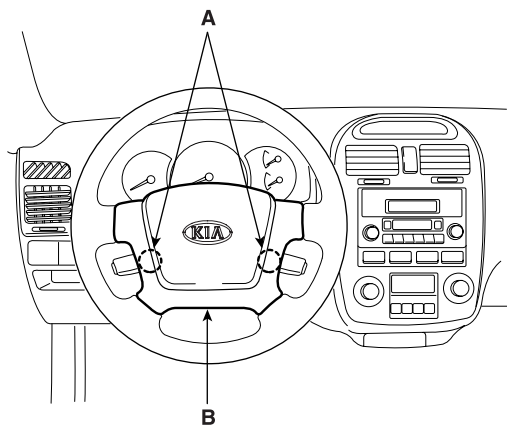

APGE003A

3. Remove the connector(A) and steering wheel lock nut(B).

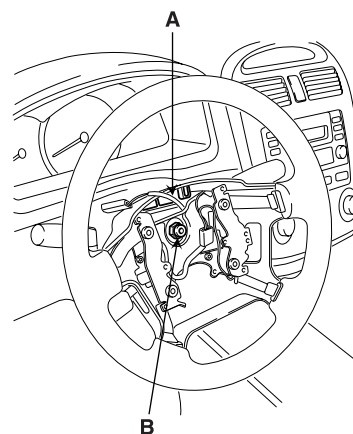

APGE003B

4. After aligning the marks on the steering shaft and wheel(A), remove the steering wheel using the special tool (09561-11002).

**NOTE**

Do not hammer on the steering wheel to remove it: it may damage the steering column.

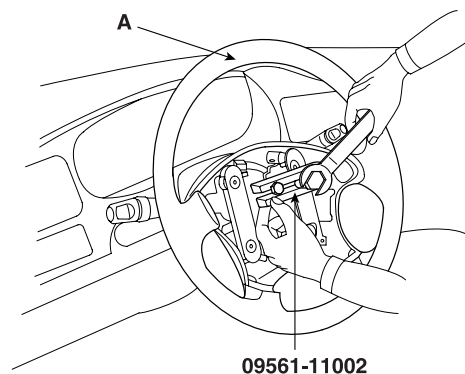

EPKE014A

5. Remove the steering column upper(A) and lower shrouds(B).

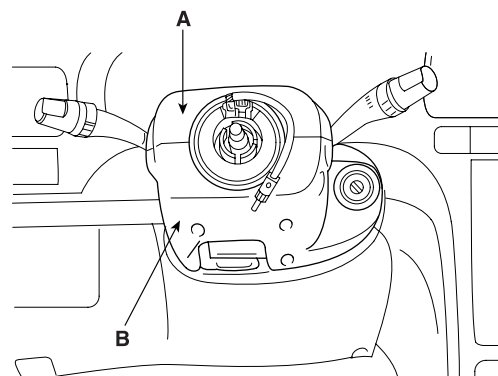

EPKE015A

6. Remove the connectors of the multifunction switch(A).

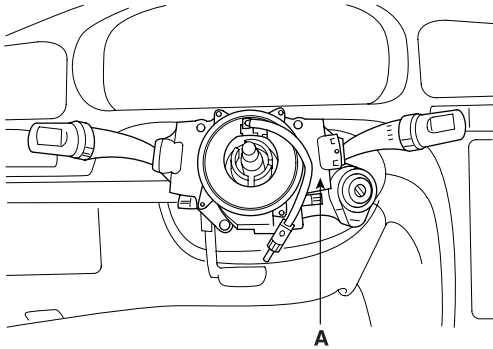

EPKE016A

7. After removing three bolts(A) in the illustration, remove the multifunction switch assembly(B).

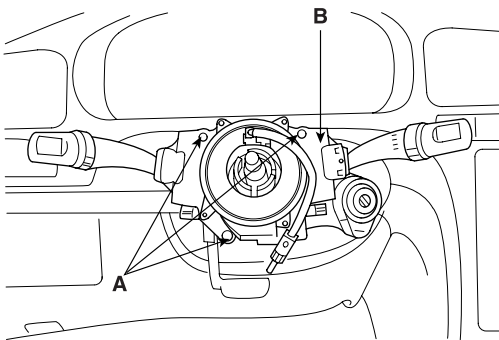

EPKE150A

8. Remove the lower crash pad(A) after loosening the four bolts(B) in the illustration.

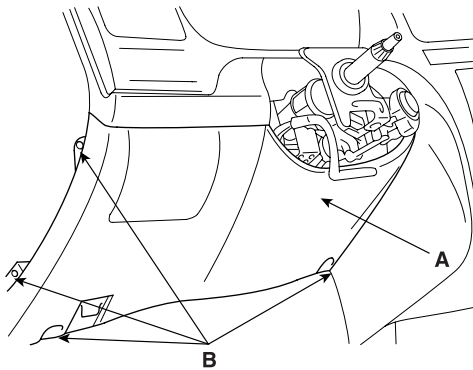

EPKE018A

9. Remove the five bolts connecting the steering column shaft(A) and the universal joint(B) as shown in the illustration.

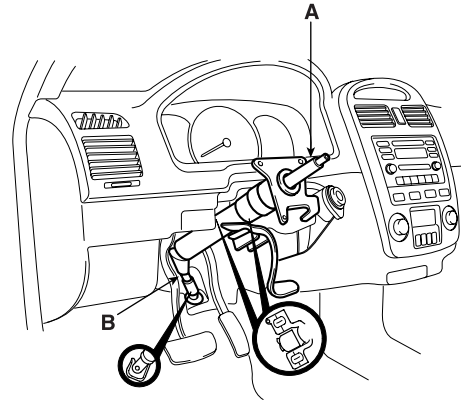

APGE003E

10. After removing the mounting bolts and nuts, remove the steering column and shaft assembly(A).

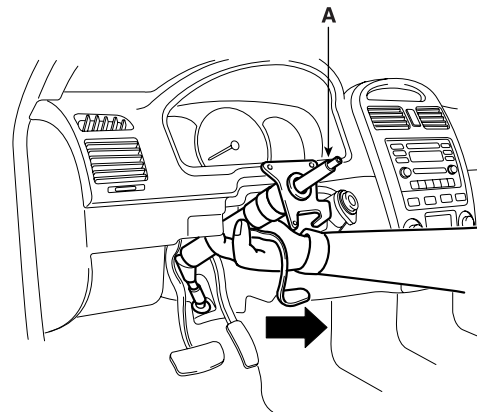

APGE003F

**INSPECTION** E7B9F63F

1. Check the steering column shaft for damage and deformation.
2. Check connections for play, damage and smooth operation.
3. Check the ball joint bearing for wear and damage.

**INSTALLATION** EBB361D9

1. Installation is the reverse of removal.

**DISASSEMBLY AND REASSEMBLY** EC1B2E38

**KEY LOCK ASSEMBLY**

1. If it is necessary to remove the key lock assembly(A), use a punch to make a groove on the head of the special bolt(B), and then use a screwdriver to remove the key lock assembly mounting bracket(C).

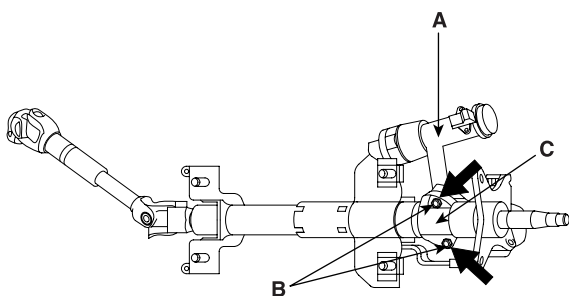

EPKE021A

2. Disassemble the key lock assembly(A) from the steering column and shaft assembly(B).

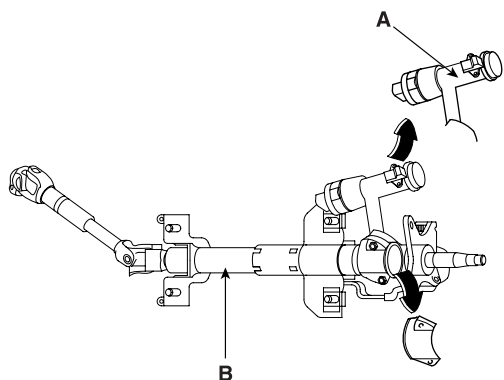

EPKE022A

3. Reassembly is the reverse of disassembly.

**UNIVERSAL JOINT ASSEMBLY**

1. Remove the bolt(A) connecting the universal joint assembly(B) and the steering column and shaft assembly(C).

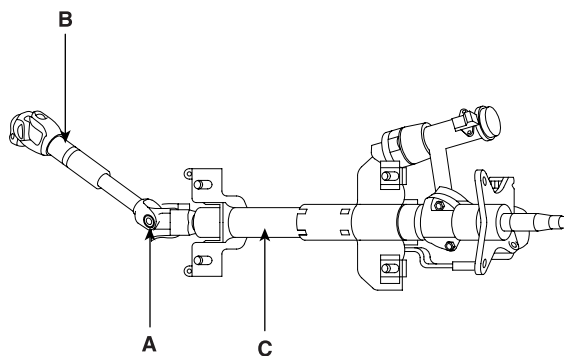

EPKE023A

2. Remove the universal joint assembly(A) from the steering column and shaft assembly(B).

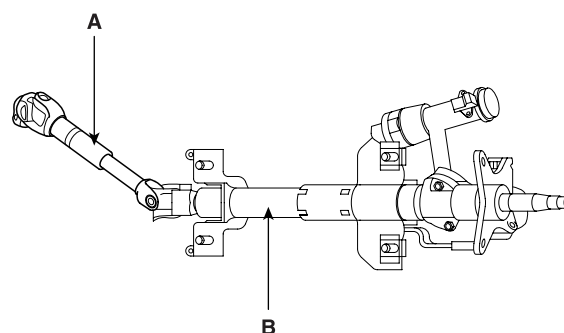

EPKE024A

3. Reassembly is the reverse of disassembly.



**REMOVAL** E18EA453

1. Drain the power steering fluid.
2. Remove the air intake hose assembly(A).

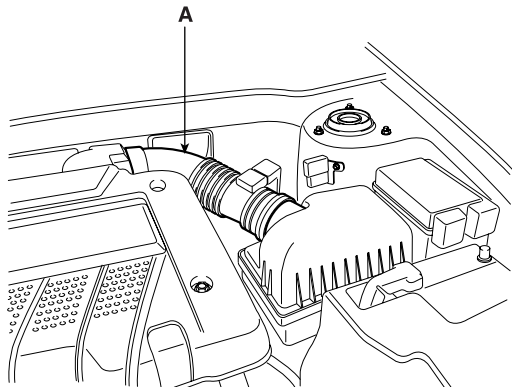

APGE005A

3. Disconnect the pressure tube and the return tube fittings from the gear box.
4. After removing the bolt(A), disconnect the universal joint assembly(B) from the gear box inside the passenger compartment.

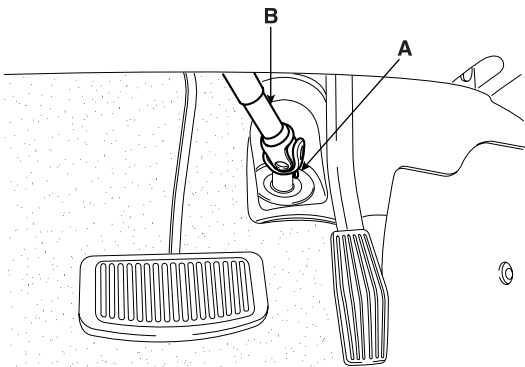

APGE005B

5. Raise up the vehicle.
6. Remove the front tires (RH/LH).
7. After removing the split pin, disconnect the tie rod(A) from the knuckle(B) by using the special tool (09568-34000).

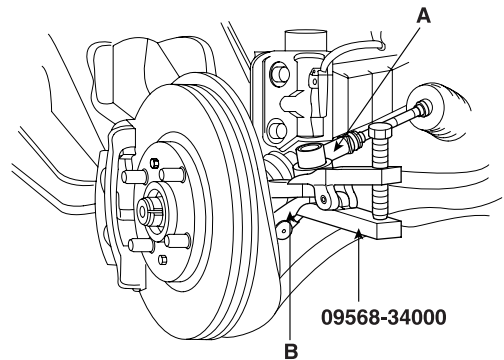

EPKE002A

8. Remove the dust cover(C) of the stabilizer bar(A) (LH side) and mounting bracket(B).

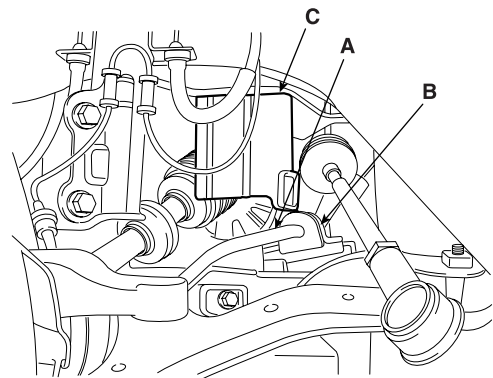

APGE005D

9. Remove the mounting bolt and mounting clamp(A) of power steering gear box, and also remove the clamp(B) holding the pressure tube and the return tube.

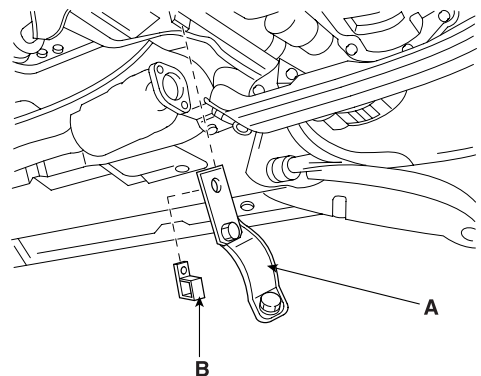

EPKE180A

10. Pull the power steering gear box assembly(A) toward the left side of the vehicle.

**NOTE**

When removing the gear box, pull it out carefully and slowly so as not to cause damage to the boots(B).

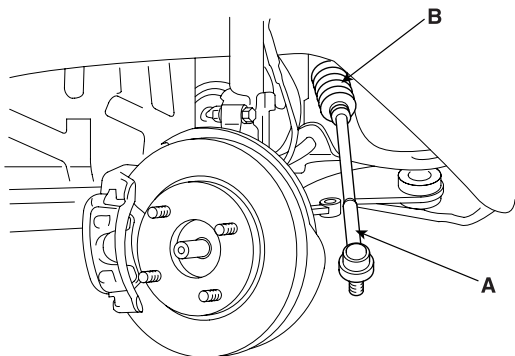

APGE005E

**INSPECTION AND ADJUSTMENT BEFORE DISASSEMBLY**

E86EBABB

Fix a brass plate or aluminum plate for protection to the jaws of a vise and mount the gear box(A) in a vise(B).

**CAUTION**

When mounting the gear box in a vise, let the installation section of it be fixed to the jaws. If other section is fixed the gear box may be damaged.

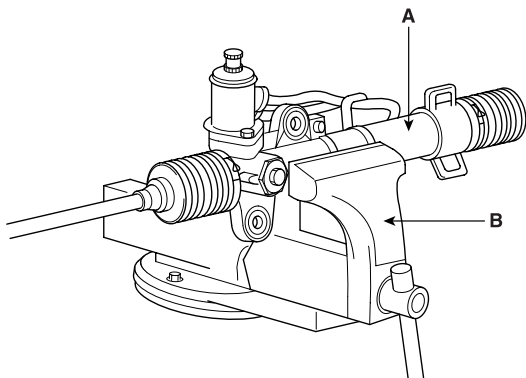

APGE006A

**TOTAL PINION PRELOAD**

1. Rotate the pinion gear for approximately 4 to 6 seconds for one rotation to measure the total pinion preload.

**Standard value**

Total pinion preload :  
0.6~1.3 Nm (6~13 kg.cm, 0.4~1.0 lb.ft)

**NOTE**

Measure the pinion preload through the entire stroke of the rack.

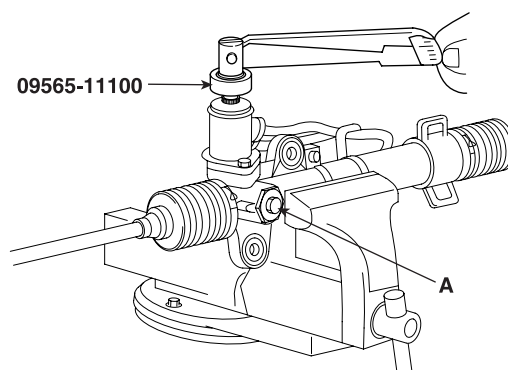

APGE006B

2. If the measured value is out of specifications, first adjust the yoke plug(A), then recheck the total pinion preload.
3. If you adjust the yoke plug but do not obtain the total pinion preload, check or replace the yoke plug components

**TIE ROD SWING RESISTANCE**

1. Rotate the tie rod severely ten times.
2. Measure the tie rod(A) swing resistance with a spring scale(B).

**Standard value**

Total rod swing resistance :  
2-5 Nm (20-50 kg.cm, 1.4-3.6 lb.ft)

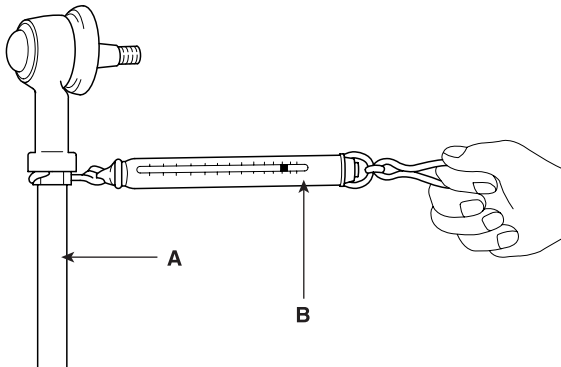

EPKE200A

3. If the measured value exceeds the standard value, replace the tie rod assembly.

**CAUTION**

*Even if the measured value is below the standard value, the tie rod that swings smoothly without excessive play may be used. If the measured value is below 0.044 Nm (0.44kg.cm, 0.03 lb-ft) replace the tie rod.*

**BELLOWS INSPECTION**

1. Inspect the bellows for damage or deterioration.
2. Make sure the bellows are secured in the correct position.
3. If the bellows are defective, replace them with new ones.

**DISASSEMBLY** E9BEF407

1. Remove the tie rod end(B) from the tie rod(A).

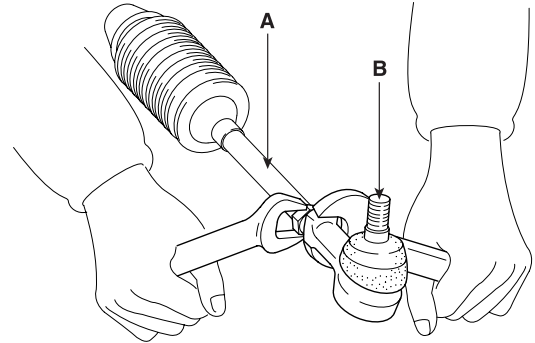

EPKE013F

2. After mounting the tie rod end(A) in a vise, remove the dust cover(B) from the ball joint.

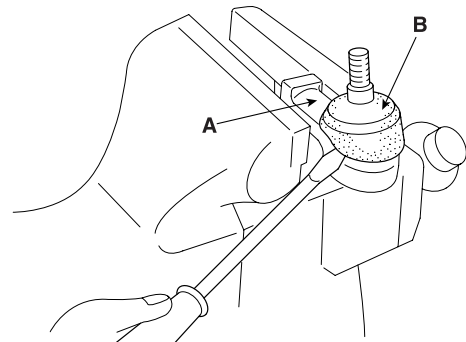

EPKE013G

3. Remove the bellows band(A).

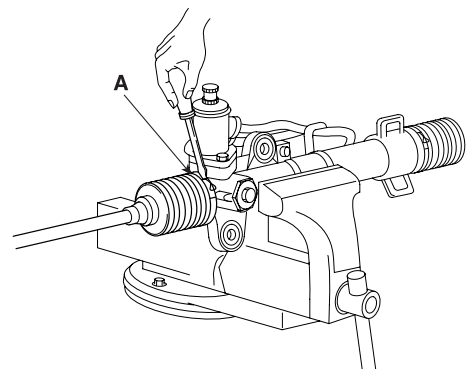

BPGE004A

4. Remove the bellows clip(A).

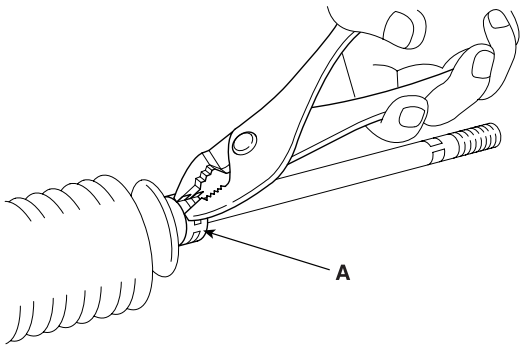

EPKE013I

5. Pull the bellows out toward the tie rod.

**NOTE**

Check for rust on the rack when the bellows are replaced.

6. Remove the feed tube from the rack housing.
7. While moving the rack slowly, drain the fluid from the rack housing.
8. Unstake the tab washer(A) which fixes the tie rod(B) and rack(C) with a chisel.

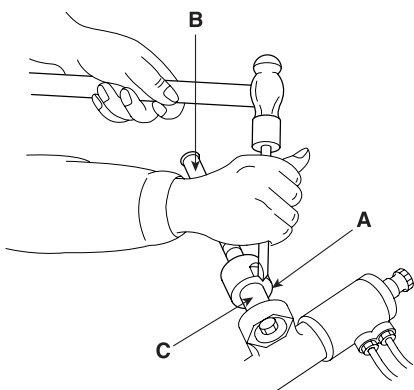

EPKE037A

9. Remove the tie rod(B) from the rack(A).



**CAUTION**

Remove the tie rod(B) from the rack(A), taking care not to twist the rack.

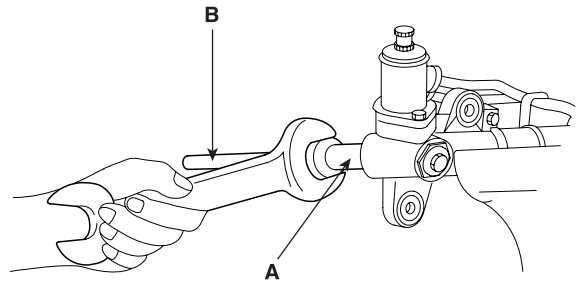

APGE007B

10. Remove the yoke plug locking nut(A).

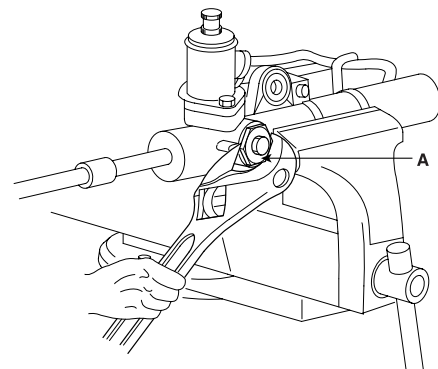

APGE007C

11. Remove the yoke plug(B) with a 14mm socket(A).

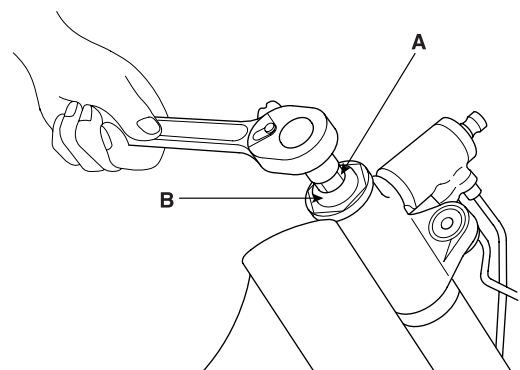

EPKE040A

**MECHANICAL POWER STEERING SYSTEM**

12. Remove the lock nut(A), yoke plug(B), rack support spring(C), rack support yoke(D) and bushing(E) from the gear box.

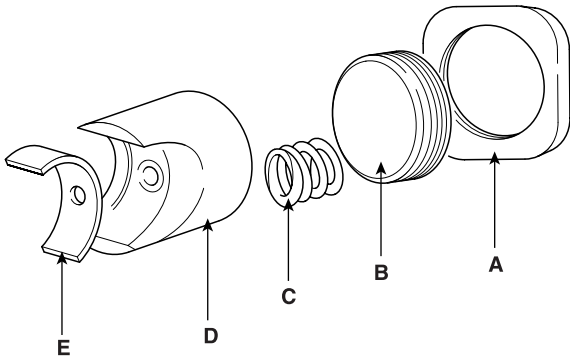

EPKE013N

15. When the end of the clip(A) comes out of the notched hole of the housing rack cylinder, turn the rack stopper(B) counterclockwise and remove the clip(A).

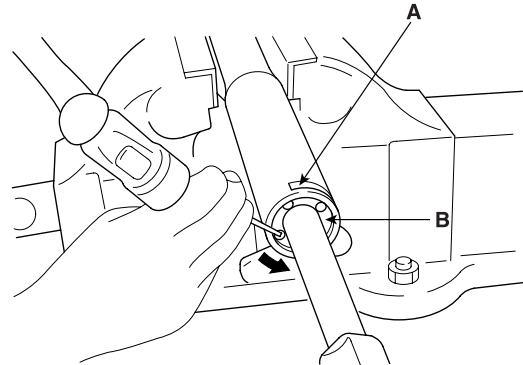

EPKE013R

13. Remove the valve body housing(A) by loosening the two bolts(B).

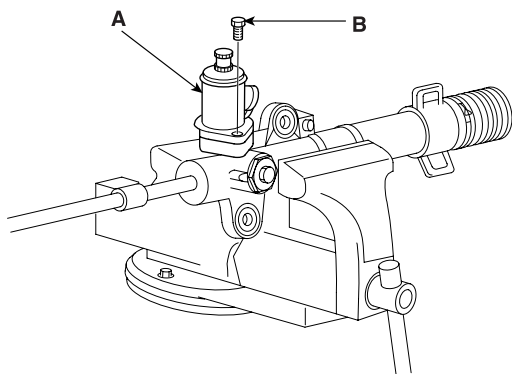

APGE007D

16. Remove the rack bushing and rack from the rack housing.

17. Remove the O-ring(A) from the rack bushing(B).

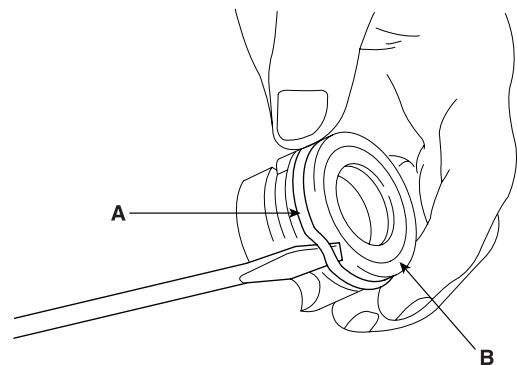

EPKE013T

14. Turn the rack stopper(A) clockwise until the end of the clip(B) comes out of the slot in the rack housing(C).

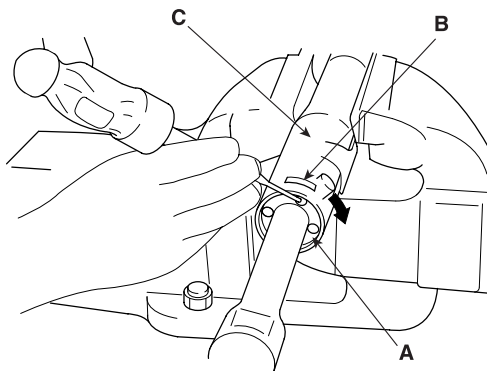

EPKE013Q

18. Remove the oil seal(A) from the rack bushing(B).

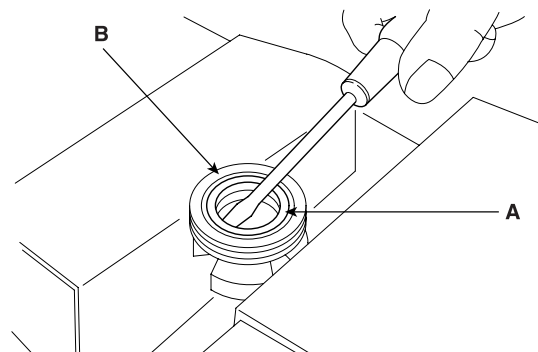

EPKE013U

19. Remove the valve body(A) from the valve body housing(B) with a soft hammer(C).

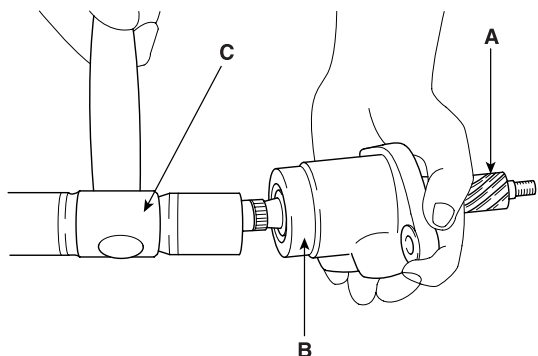

EPKE210A

20. Using the special tool, remove the oil seal and ball bearing from the valve body housing.
21. Remove the oil seal and O-ring from the rack housing.

**CAUTION**

**Be careful not to damage the pinion valve cylinder inside of the rack housing.**

22. Using the special tool(09573-21200, 09555-21000), remove the oil seal(A) from the rack housing.

**CAUTION**

**Be careful not to damage the rack cylinder inside of the rack housing.**

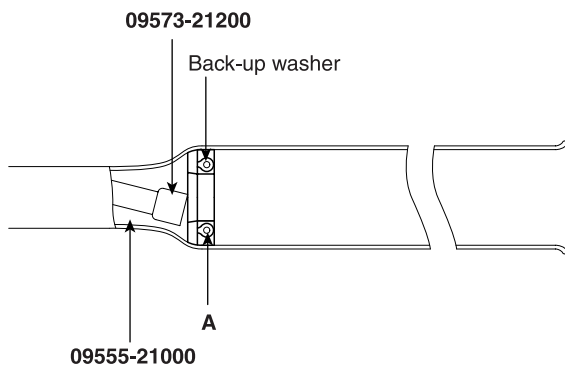

EPKE210B

**INSPECTION** ED89E8CF

**1. Rack**

- Check for rack tooth face damage or wear
- Check for oil seal contact surface damage
- Check for rack bending or twisting
- Check for oil seal ring damage or wear
- Check for oil seal damage or wear

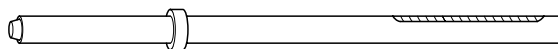

EPA9013Y

**2. Pinion valve**

- Check for pinion gear tooth face damage or wear
- Check for oil seal contact surface damage
- Check for seal ring damage or wear
- Check for oil seal damage or wear

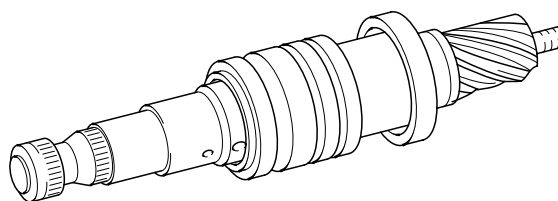

EPA9013Z

**MECHANICAL POWER STEERING SYSTEM**

**ST -23**

**3. Bearing**

- Check for seizure or abnormal noise during rotating a bearing
- Check for excessive play
- Check for missing needle bearing rollers

**4. Others**

- Check for damage of the rack housing cylinder bore
- Check for boot damage, cracking or aging

**REASSEMBLY**

EE28750B

1. Apply the specified fluid to the entire surface of the rack oil seal.

---

Recommended fluid : PSF-III

---

2. Install the backup washer and oil seal(A) to the specified position in the rack housing.

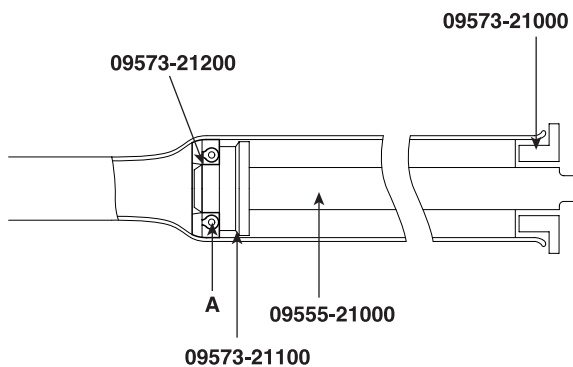

APGE007F

3. Apply the specified fluid to the entire surface of the rack bushing oil seal.

---

Recommended fluid : PSF-III

---

4. Install the oil seal(A) in the rack bushing(B).

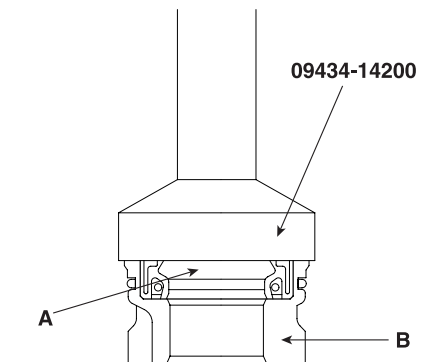

EPKE230B

5. Apply the specified fluid to the entire surface of the O-ring and install it in the rack bushing.

6. Apply the specified grease to the rack teeth.

---

**Recommended grease**

Multipurpose grease SAE J310a NLGI No.2

---

**NOTE**

Do not plug the vent hole(A) in the rack with grease.

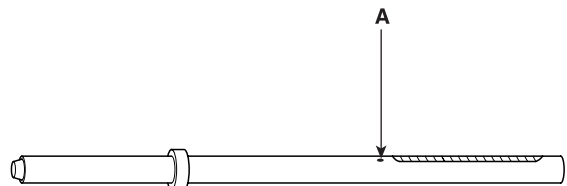

EPKE014E

7. Insert the rack(A) into the rack housing(B) and install the rack bushing(C) and rack stopper(D).

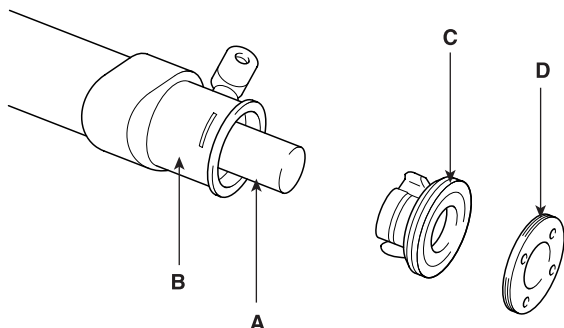

EPKE230I

9. Install the oil seal and the ball bearing in the valve body(A).

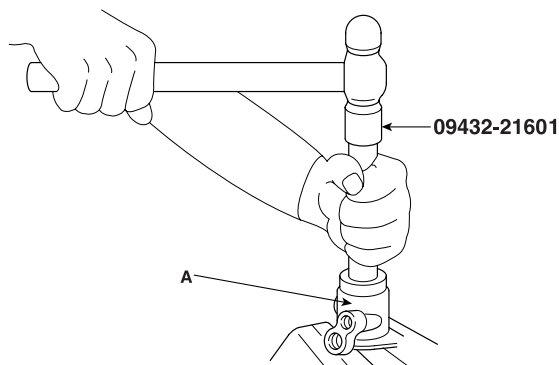

APGE008G

8. Push in the rack stopper until the clip groove of the rack stopper is aligned with the notched hole of the rack housing. Install the clip(A) while turning the rack stopper.



**CAUTION**

*The clip(A) end should not be visible through the notched hole of the rack housing.*

10. After applying the specified fluid and grease to the pinion valve assembly(A), install it in the rack housing assembly.

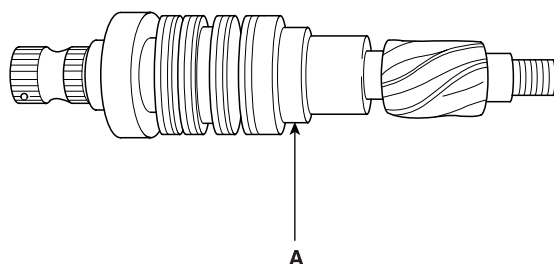

EPKE230E

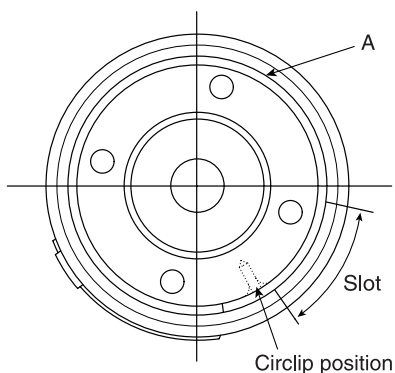

EPKE014G

11. After applying the specified fluid to the oil seal, install it in the rack housing, and fix the valve body assembly(A) and O-ring in the gear box(B).

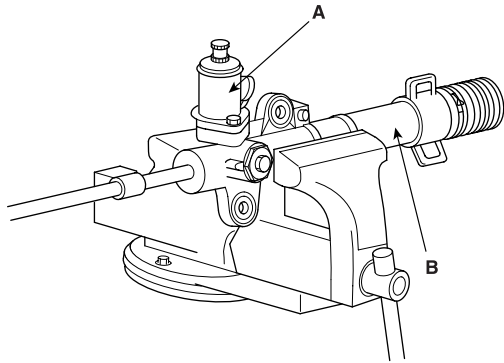

APGE008B

12. Install the tab washer and the tie rod and stake the tab washer(A) end at two points over the tie rod.

**NOTE**

1. Align the tab washer pawls with the rack grooves.
2. Always use a new tab washer.

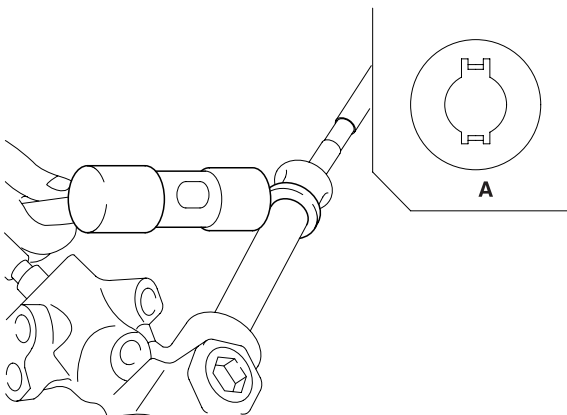

EPKE230F

13. Install the bushing(A), rack support yoke(B), rack support spring(C), lock nut(E) and yoke plug(D) in the order shown in the illustration. Apply semi-drying sealant to the threaded section of the yoke plug before installation.

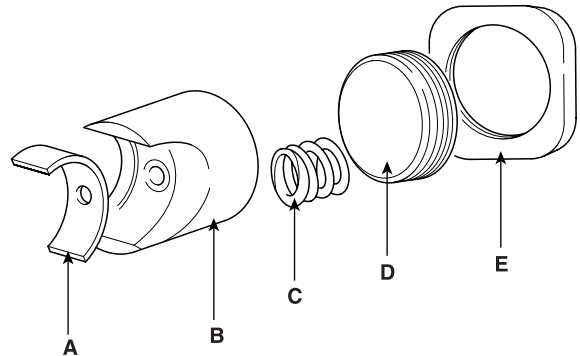

BPGE005A

14. With the rack placed in the center position, attach the yoke plug to the rack housing. Tighten the yoke plug to 15 Nm (150 kg.cm, 11 lb.ft), using a 14 mm socket. Loosen the yoke plug approximately from 30° to 60° and tighten the locking nut to the specified torque.

**Tightening torque**

50~70 Nm (500~700 kg.cm, 36~51 lb.ft)

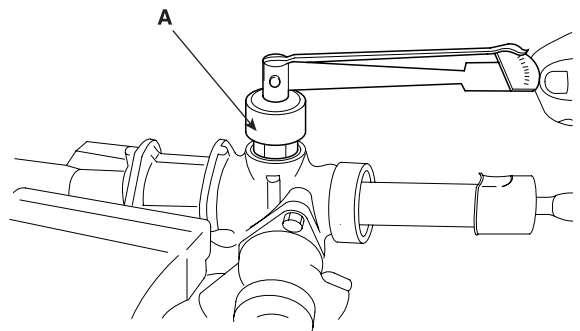

APGE008F

15. Tighten the feed tube to the specified torque and install the mounting rubber using adhesive.

16. Apply the specified grease to the bellows mounting position (fitting groove) of the tie rod.

Recommended grease: Silicone grease

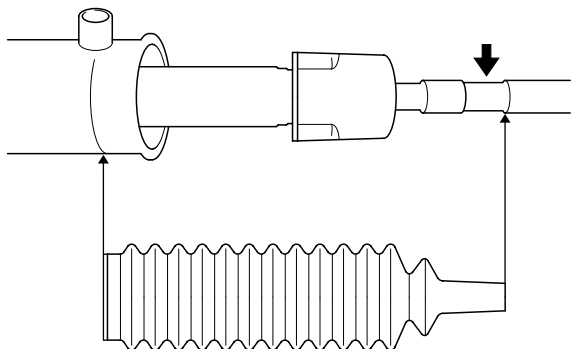

APGE008C

17. Install the new attaching band to the bellows.

**NOTE**

When the bellows are installed, a new band must be used.

18. Install the bellows in position, taking care not to twist it.
19. Fill the dust cover inner side and lip with the specified grease, and fix the dust cover in position with the clip ring attached in the groove of the tie rod end.

**Recommended grease**

A : POLY LUB GLY 801K or equivalent  
B : SHOWA SUNLIGHT MB2 or equivalent  
Dust cover inner side and lip : THREE BOND

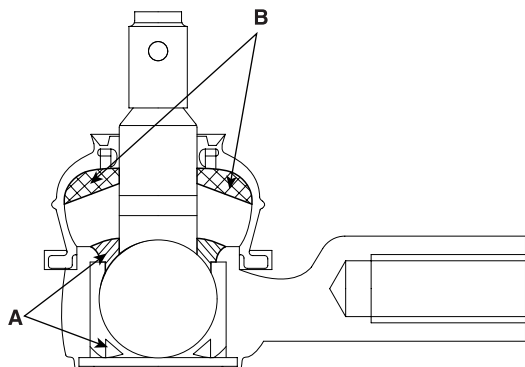

EPKE043A

20. Install the tie rods so that the length of the left and right tie rods equals the standard value.

**Standard value**

Tie rod free length(A) : 203.6 mm (8 in.)

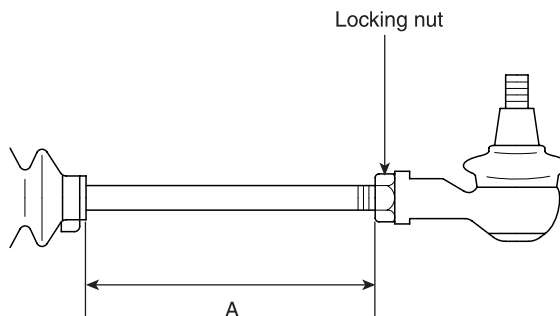

BPGE005B

21. Check for total pinion preload.

**INSTALLATION**

EC474059

1. Push in the power steering gear box assembly on the left side of the vehicle.

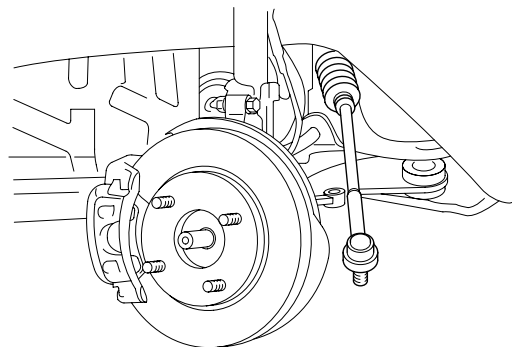

APGE008E

2. Installation is the reverse of removal.
3. After installation, air bleed the system.

POWER STEERING HOSES

COMPONENTS EB106FB6

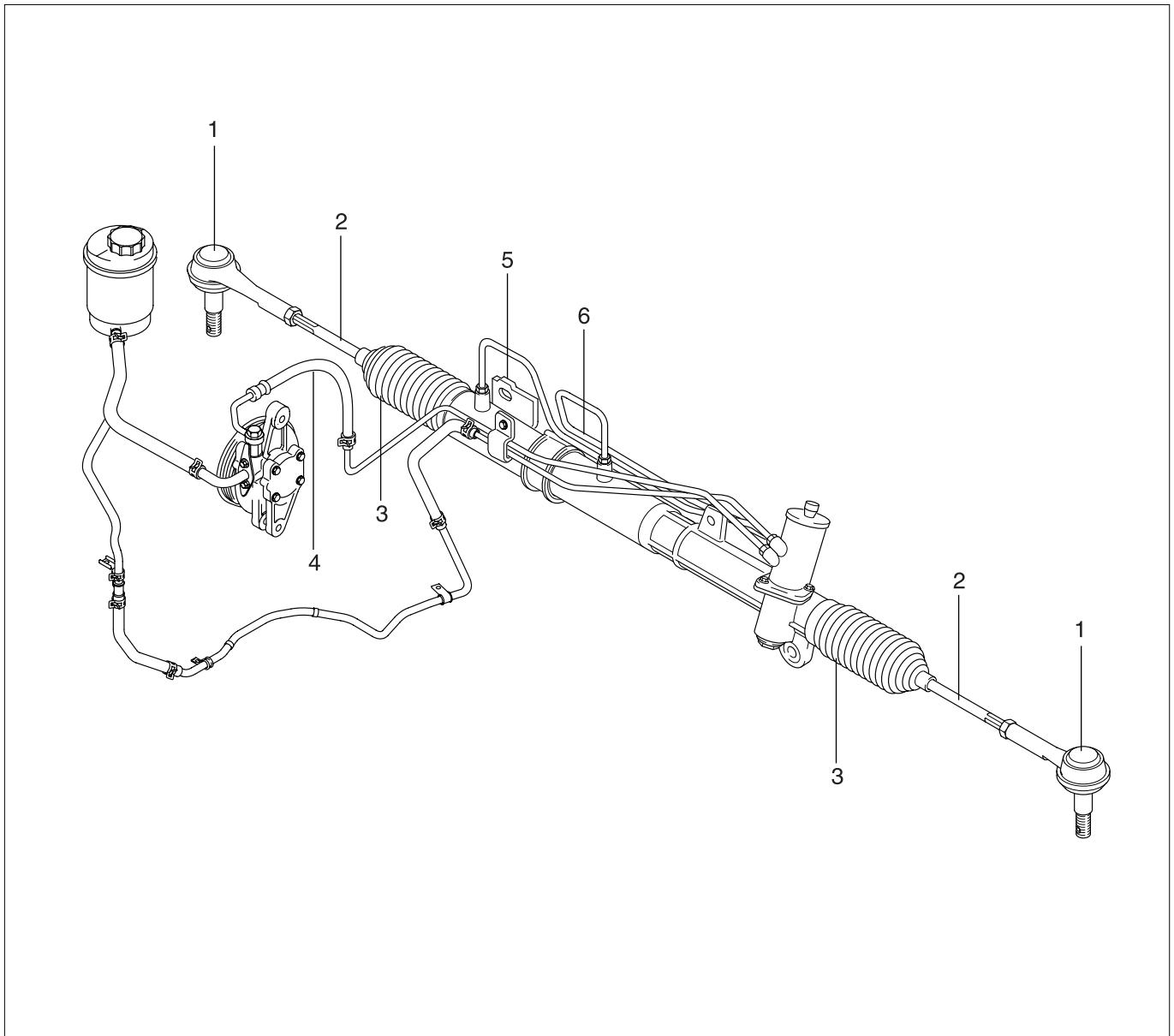

- 1. Tie rod end
- 2. Tie rod
- 3. Bellows
- 4. Pressure hose and tube assembly
- 5. Power steering gear box mounting clamp
- 6. Feed tube

BPGE006A

**REMOVAL AND INSTALLATION** EE1977DB

While installing the tube and hose assembly, be sure to align white marks(A) on each fitting.

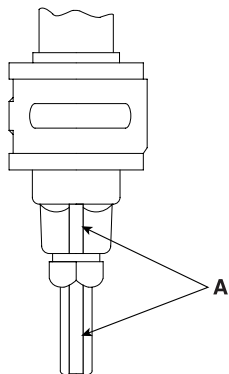

EPKE260A

**PRESSURE HOSE AND TUBE**

1. Remove the air intake hose assembly(A).

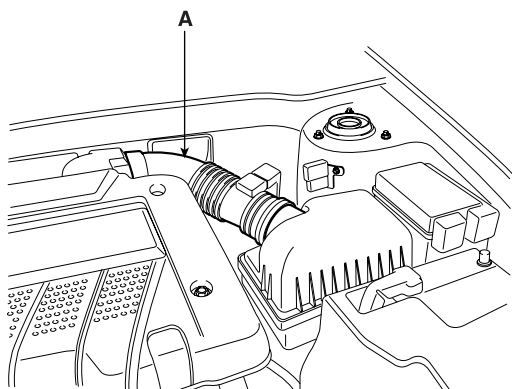

APGE005A

2. Disconnect the pressure tube fitting at the gear box side.

3. Lift up the vehicle and remove the mounting clamp(A) which is holding both the pressure tube and the return tube.

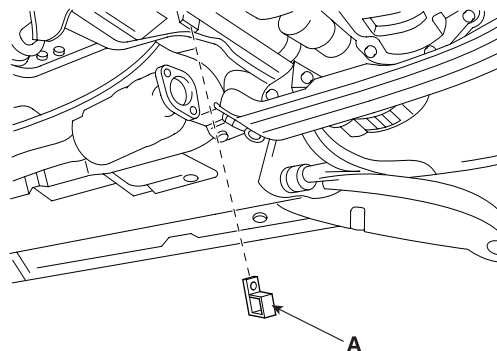

EPKE180B

4. Lower the vehicle and remove the connector(A) (24mm).

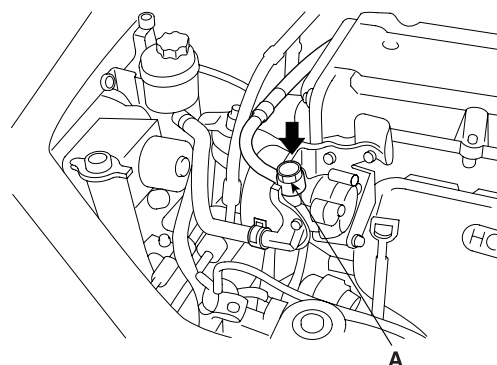

APGE009A

5. Remove the pressure hose and tube assembly.

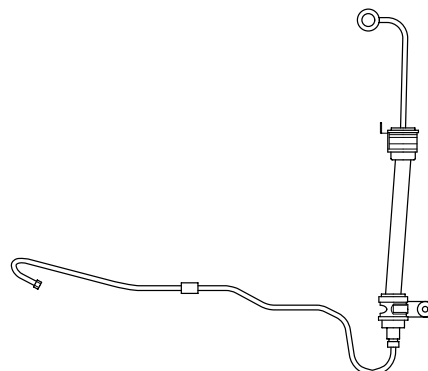

KPKA065A

6. Installation is the reverse of removal.

**NOTE**

1. Install the pressure hose and tube so that they are not twisted and they do not come in contact with any other parts.
2. After installation, air bleed the system.

**RETURN TUBE AND HOSE**

1. Remove the return tube(A) and hose mounting clamps(B).

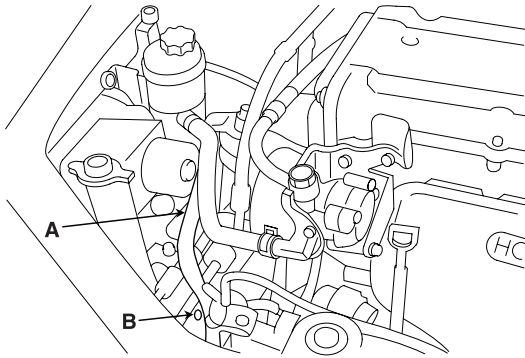

APGE009B

2. Remove the air intake hose assembly(A).

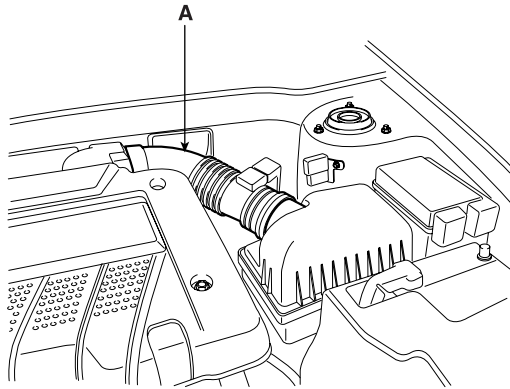

APGE005A

3. Disconnect the pressure tube and the return tube fittings at the gear box assembly.
4. Raise the vehicle and remove the mounting clamp(A) that is holding both the pressure tube and the return tube.

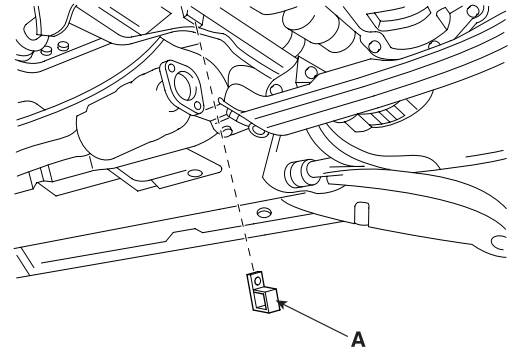

EPKE180B

5. Lower the vehicle and disconnect the clamp holding the return tube and hoses.

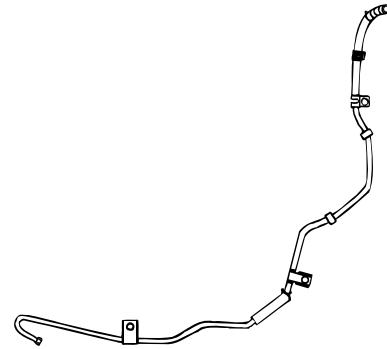

KPKA066A

6. Installation is the reverse of removal.

**NOTE**

1. Install the return tube and hoses so that they are not twisted and it does not come in contact with any other parts.
2. After installation, air bleed the system.

**INSPECTION**

EA659904

1. Twisting the hose by hand, check for cracks.
2. Check that the hose does not contact other components.

## POWER STEERING OIL PUMP

### COMPONENTS EE927E42

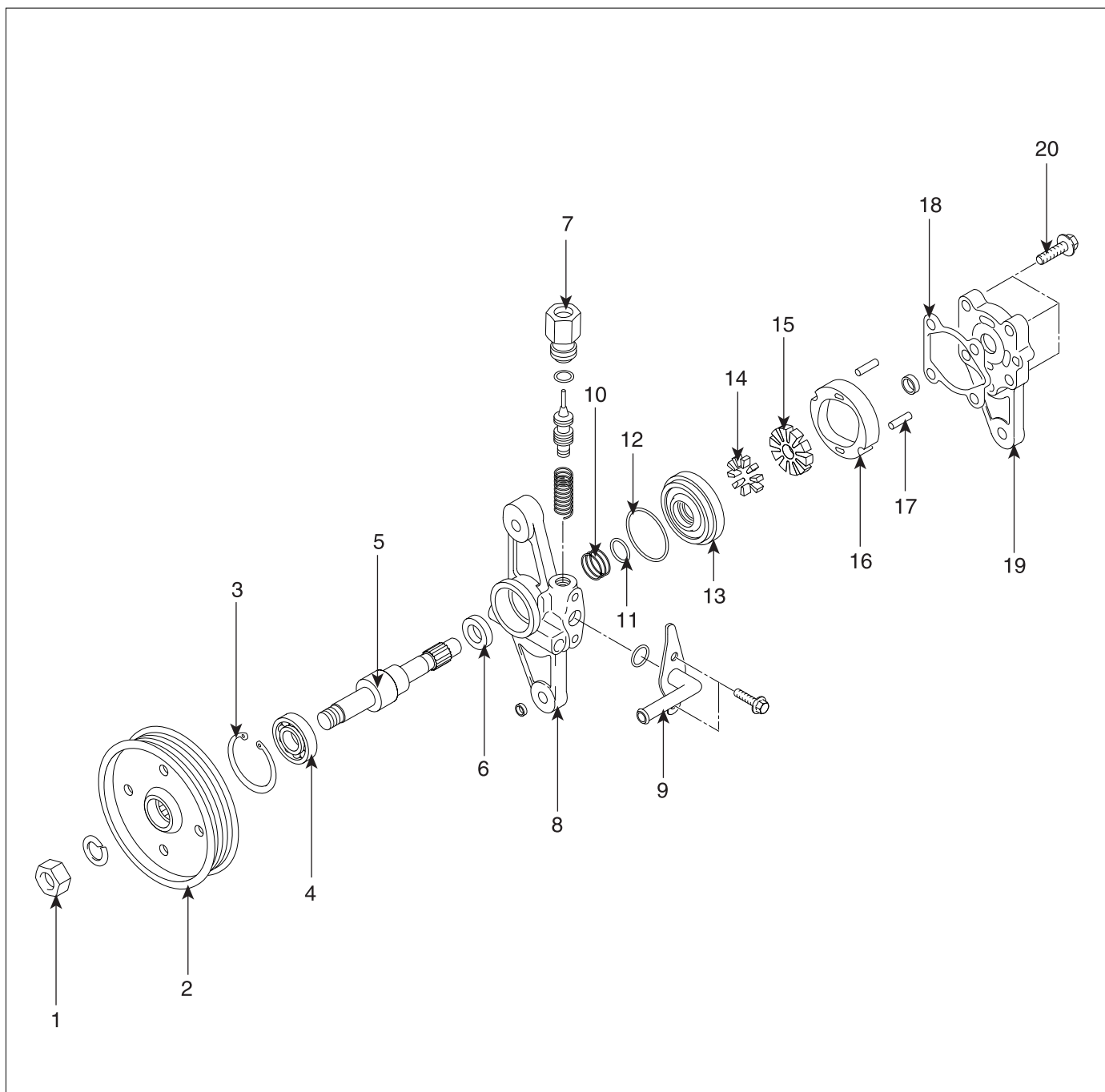

- 1. Pulley nut
- 2. Pulley
- 3. Snap ring
- 4. Bearing
- 5. Driver shaft
- 6. Oil seal
- 7. Connector

- 8. Front housing
- 9. Suction pipe
- 10. Slide plate spring
- 11. O-ring (Inner)
- 12. O-ring (Outer)
- 13. Oil pump side plate
- 14. Vane

- 15. Rotor
- 16. Cam ring
- 17. Lock pin
- 18. Gasket
- 19. Oil pump cover assembly
- 20. Mounting bolt

BPGE007A

## MECHANICAL POWER STEERING SYSTEM

ST -31

### REMOVAL E8AF3AB6

1. Remove the pressure hose(A) from the oil pump(B).
2. Disconnect the suction hose(C) from the suction connector(D) and drain the fluid into a container.

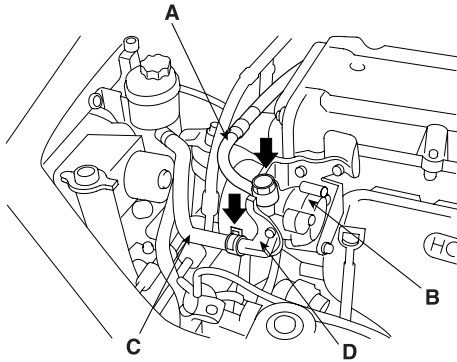

EPKE044B

3. Loosen the oil pump mounting bolts to remove the V belt.
4. Loosen the tension adjusting bolt(A).

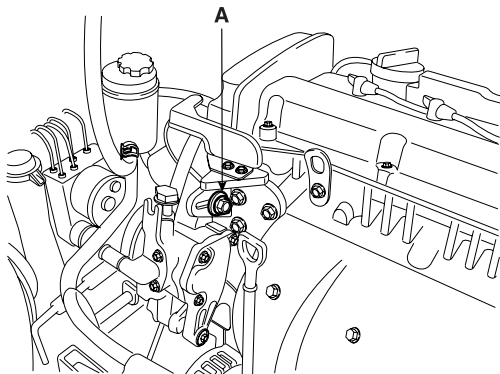

APGE011A

5. Remove the power steering drive belt(A) from the power steering oil pump pulley.

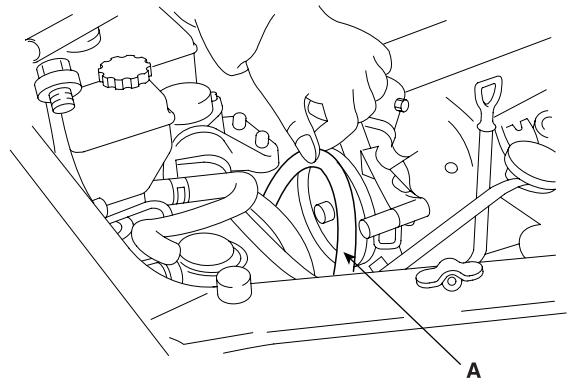

APGE011B

6. Remove the power steering oil pump mounting bolt and the tension adjusting bolt.
7. Remove the power steering oil pump assembly.

#### **NOTE**

*Be careful not to drip fluid from the power steering oil pump.*

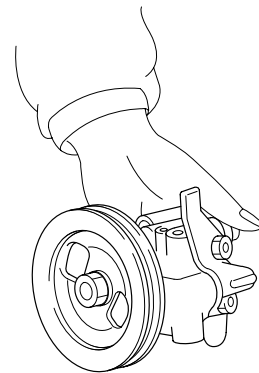

KPKA048A

**DISASSEMBLY** EDBEEBA9

1. Remove two bolts(A) from the oil pump body(B), and then remove the suction pipe(C) and O-ring.

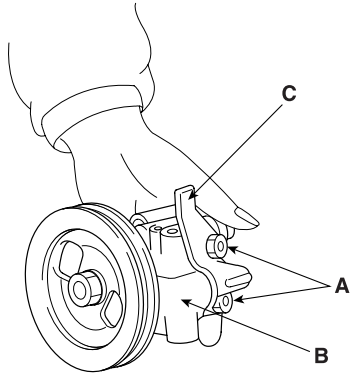

EPKE050A

7. Remove the side plate spring(C).

**NOTE**

When assembling, use a new gasket and O-ring.

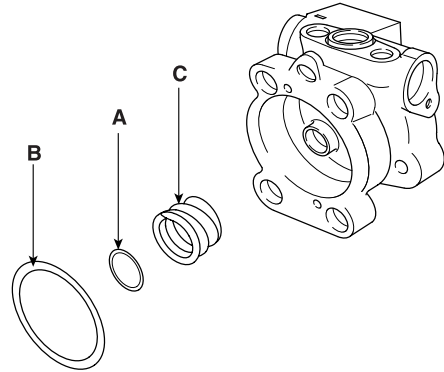

EPKE055A

2. Loosen the four bolts and remove the oil pump cover assembly.
3. Remove the cam ring.
4. Remove the rotor and vanes.
5. Remove the oil pump side plate.

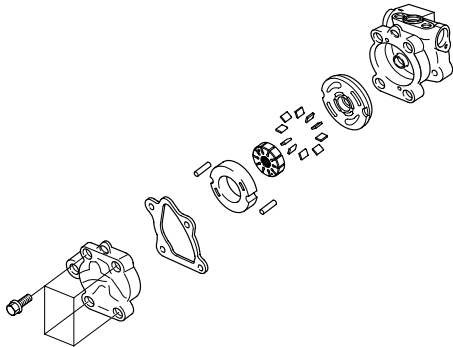

KPKA046A

6. Remove the inner(A) and outer O-ring(B).

8. Mount the pulley in a vise and remove the pulley nut and the spring washer.

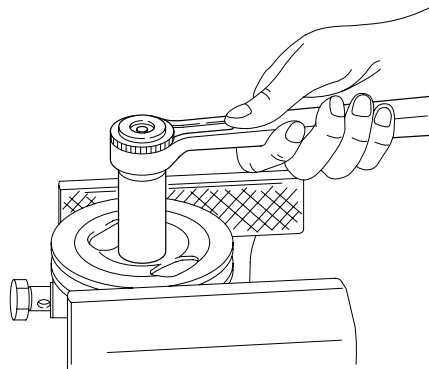

KPKA056A

9. Pull the pulley out.

10. After removing the snap ring(A) of the shaft with snap ring pliers, remove the dust spacer(B).

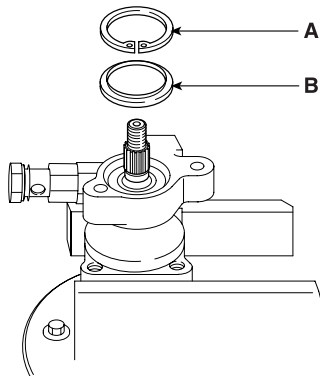

EPKE057A

11. Tap the rotor side of the shaft slightly with a plastic hammer(A) to remove the shaft(B).

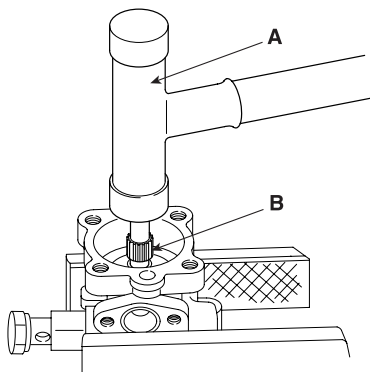

EPKE058A

12. Remove the oil seal(A) from the oil pump body(B).

**NOTE**

When assembling, use a new oil seal.

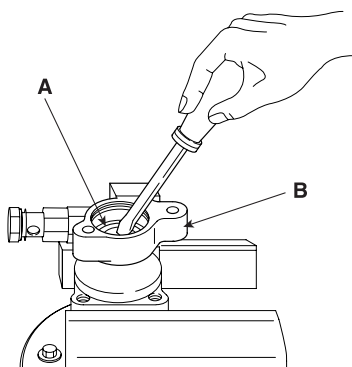

EPKE059A

13. Remove the connector from the oil pump body, and take out the flow control valve and the flow control spring.
14. Remove the O-ring from the connector.

**CAUTION**

Do not disassemble the flow control valve.

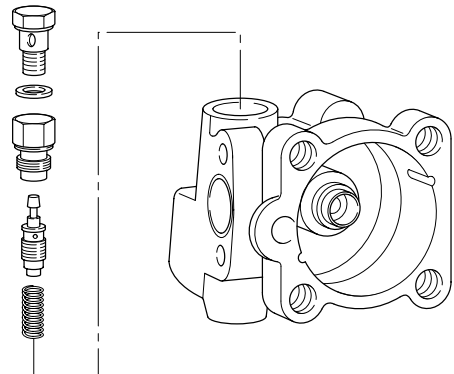

KPKA060A

**INSPECTION**

1. Check the free length of the flow control spring.

Free length of the flow control spring : 36.5mm (1.4in.)

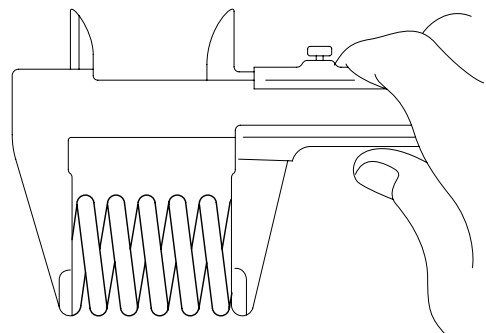

KPKA068A

2. Check that the flow control valve is not bent.
3. Check the shaft for wear and damage.
4. Check the V belt for wear and deterioration.
5. Check the grooves of the rotor and vanes for stratified abrasion.
6. Check the contact surface of the cam ring and vanes for stratified abrasion.

7. Check vanes for damage.
8. Check that there is no striped wear in the side plate or contacting part between the shaft and the pump cover surface.

**REASSEMBLY** E4694A56

1. Install the flow control spring, the flow control valve and the connector into the pump body.

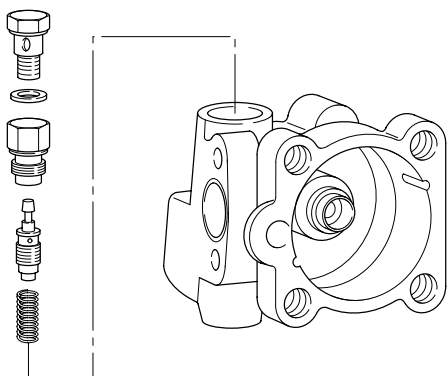

KPKA060A

2. Install the oil seal in the pump body by using the special tool(09222-32100).

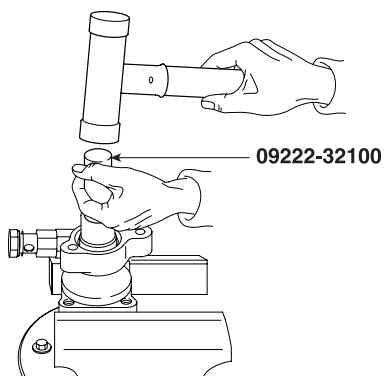

EPKE061A

3. After inserting the shaft assembly(A) into the pump body, install the dust spacer(B) and snap ring(C).

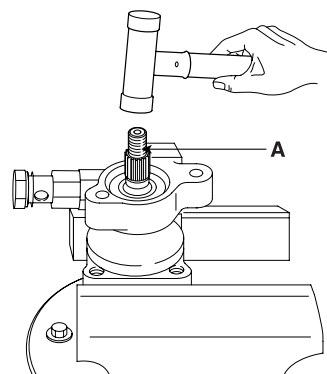

KPKA062A

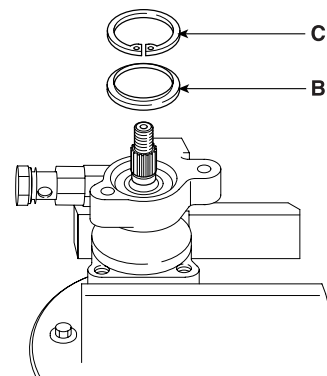

EPKE057B

4. Install the pump pulley(A).

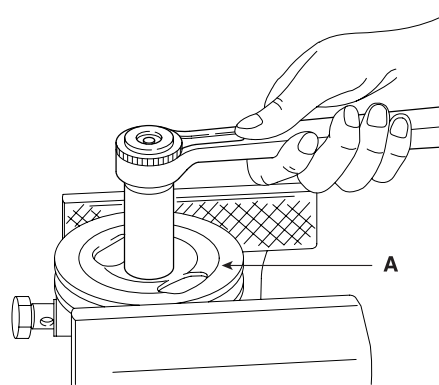

EPKE056A

5. Install the spring(A) and inner O-ring(B).

- 6. Insert the outer O-ring in the oil pump side plate and then install it in the pump body.

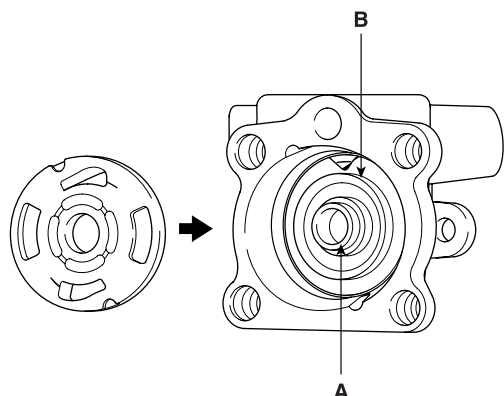

EPKE300A

- 10. Install the gasket and oil pump cover assembly.
- 11. Install the suction pipe and O-ring.

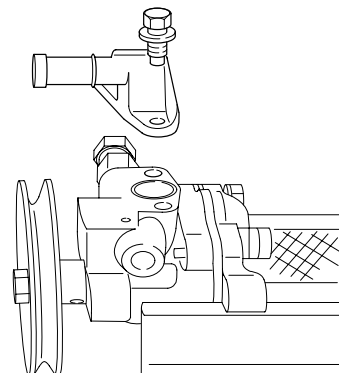

KPKA063A

- 7. After inserting the lock pin into the groove of the front housing, install the cam ring attending to the direction.

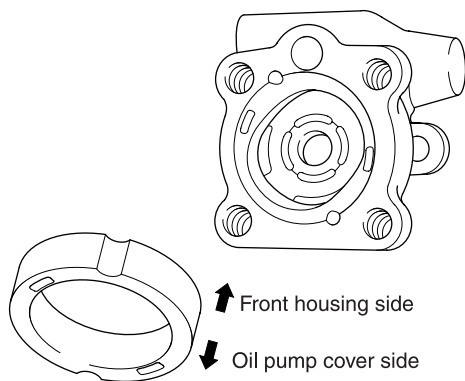

EPKB300B

**INSTALLATION**

E63D47BE

- 1. After installing the oil pump to the oil pump bracket, install the V belt and tighten the bolt(A) adjusting tension to the specified torque.

Oil pump adjusting bolt :  
35~50 Nm (350~500 kg·cm, 25~36 lb·ft)

- 8. Install the rotor.
- 9. Install vanes(A) so that the rounded edges face outward.

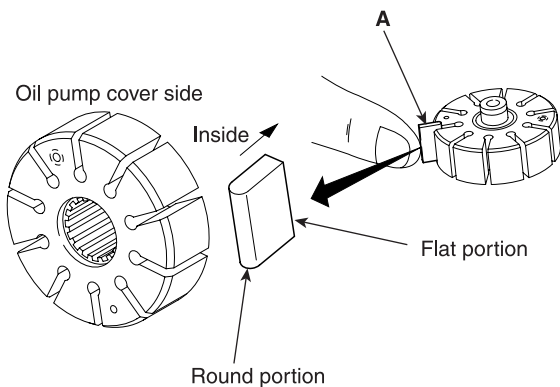

EPKE300C

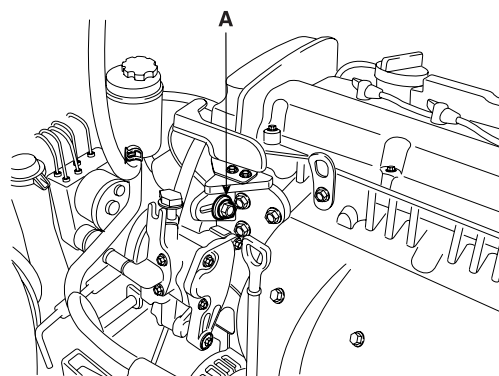

APGE011A

- 2. Install the suction hose.



**CAUTION**

**Install the pressure hose to the oil pump.**

3. Install the pressure hose(A) to the oil pump(B).

 **NOTE**

*Install the pressure hose carefully that it does not twist and come in contact with other components.*

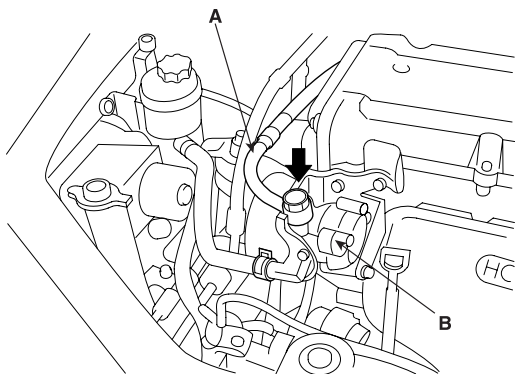

BPGE008A

4. Add power steering fluid (PSF-III).
5. Air bleed the system.
6. Check the oil pump pressure.