

2009 > G 3.3 DOHC >

**SPECIFICATIONS****FRONT SUSPENSION**

Item		Specification	
Suspension type		Double wishbone coil spring	
Shock absorber	Type	Gas pressurized	
	Stroke	112mm (4.41in.)	
	Damping force (Piston speed: 0.3m/s)	Compression	82±15kg (804±147N)
		Extension	124±18kg (1217±177N)
I.D. color		Red	
Coil spring	Free height	341.8mm	
	I.D. color	Red	

REAR SUSPENSION

Item		Specification	
Suspension type		5 link coil spring	
Shock absorber	Type	Gas pressurized	
	Stroke	186mm (7.32in.)	
	Damping force (Piston speed: 0.3m/s)	Compression	78±14kg (765±137N)
		Extension	158±23kg (1550±226N)
I.D. color		Yellow	
Shock absorber (Self levelizer)	Type	Gas pressurized	
	Stroke	180mm (7.09in.)	
	Damping force (Piston speed: 0.3m/s)	Compression	36±9kg (350±85N)
		Extension	175±23 (1710±220N)
I.D. color		Yellow	
Coil spring	Free height	353.9mm (13.93in.)	
	I.D. color	Blue	
Coil spring (Self levelizer)	Free height	360.4mm (14.19in.)	
	I.D. color	Purple	

WHELL AND TIRE

Item		Specification
Tire		225/75 R16
		245/70 R16
		245/65 R17
Wheel		7.0J × 16
		7.0J × 17
Tire pressure	Front	2.1kg/cm ² (30psi)

	Rear	2.1kg/cm ² (30psi)
--	------	-------------------------------

WHEEL ALIGNMENT

TYPE		SPECIFICATION
Front	Toe	0°±0.2° (0±0.079in.)
	Camber angle	0°±0.5°
	Caster angle	3.89°±0.5°
	King pin angle	12.13°
Rear	Camber	0.5°±0.5°
	Toe-in	0° ± 0.2° (0±0.079)

2009 > G 3.3 DOHC >

**SPECIAL SERVICE TOOL**

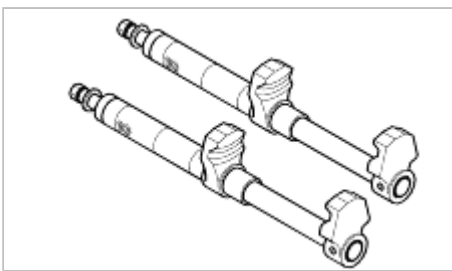
Tool (Number and name)	Illustration	Use
OK2A1 341 001A Coil spring compressure	 The illustration shows two identical coil spring compressors. Each tool consists of a long, cylindrical metal body with a threaded end on one side and a hook-like attachment on the other. The hook is designed to grip the top of a coil spring. The two tools are shown from a perspective view, one slightly behind the other.	For removal of front shock absorber spring





2009 > G 3.3 DOHC >

**TROUBLESHOOTING**

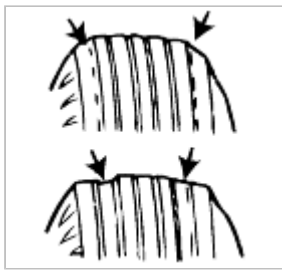
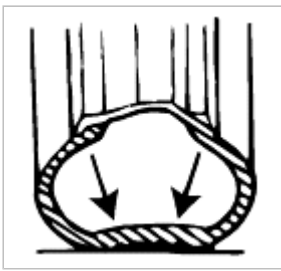
Symptoms	Possible causes	Remedy
Excessive vehicle rolling	Broken or deteriorated stabilizer	Replace
	Damaged shock absorber	Replace
Abnormal noise	Loose mounting parts	Retighten
	Broken or worn wheel bearing	Replace
	Shock absorber malfunction	Replace
	Damaged tire	Replace
Poor riding	Excessive tire inflation pressure	Adjust the tire inflation the pressure
	Shock absorber malfunction	Replace
	Loose wheel nut	Tighten to the specified torque
	Distorted or broken coil spring	Replace
	Damaged tire	Replace
	Worn bushing	Replace
Vehicle leans to one side	Deformed arm assembly	Replace
	Worn bushing	Replace
	Distorted or broken coil spring	Replace
Hard steering	Improper front wheel alignment	Repair
	Excessive turning resistance of lower arm ball joint	Replace
	Lack of tire inflation pressure	Adjust
	Power steering malfunction	Repair or Replace
Wandering	Improper front wheel alignment	Repair
	Worn or loose lower arm bushing	Retighten or Replace
Bottoming	Broken or worn coil spring	Replace

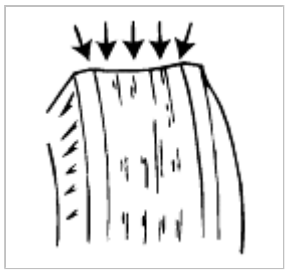
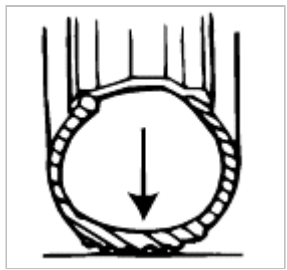
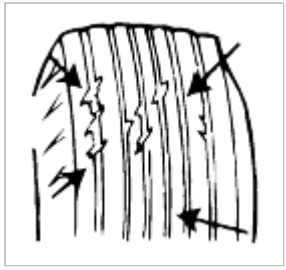
DIAGNOSIS (TIRES/WHEELS)

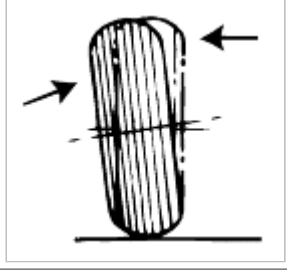
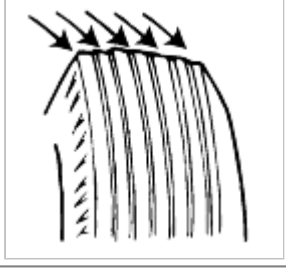
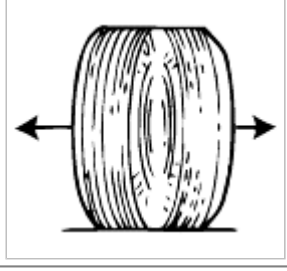
Problem	Possible Cause	Action
Rapid wear at shoulders 	Under-inflation or lack of rotation 	Adjust the tire pressure
Rapid wear at center	Over-inflation or lack of rotation	

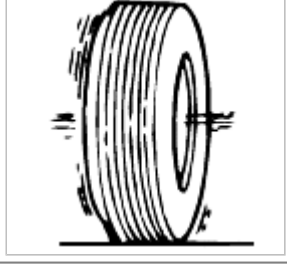
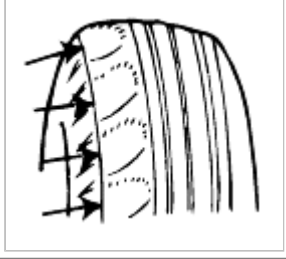
		
<p>Cracked treads</p>	<p>Under-inflation</p>	
		
<p>Wear on one side</p>	<p>Excessive camber</p>	<p>Inspect the camber</p>
		
<p>Feathered edge</p>	<p>Incorrect toe</p>	<p>Adjust the toe-in</p>
		
<p>Bald spots</p>	<p>Unbalanced wheel</p>	<p>Adjust the imbalanced wheels</p>
		
<p>Scalloped wear</p>	<p>Lack of rotation of tires or worn or out-of-alignment suspension</p>	<p>Rotate the tires inspect the front suspension alignment</p>
		

2009 > G 3.3 DOHC >

**REMOVAL**

1. Loosen battery cable and mounting bolt and then remove battery.

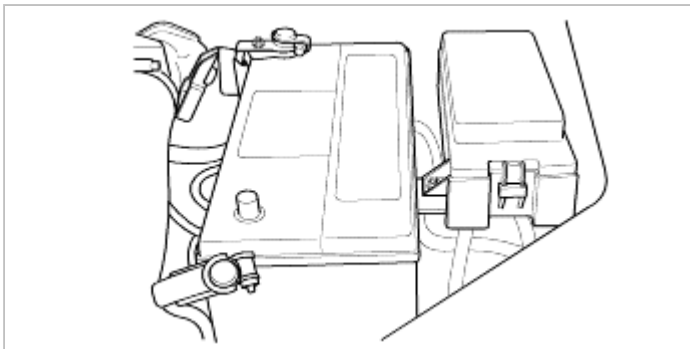

2. Remove three shock absorber mounting block nuts from the mounting block.

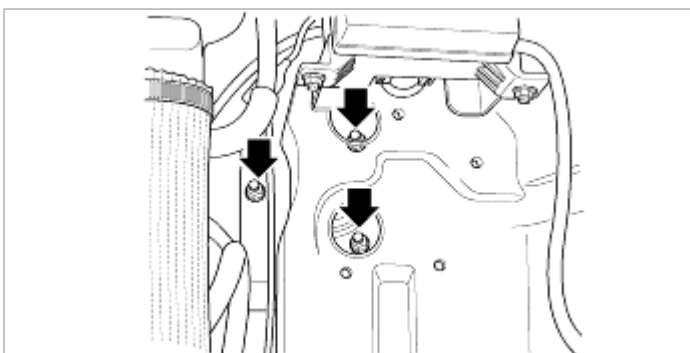

3. Raise the front of the vehicle and support it with safety stands.

4. Remove the front wheels.

5. Remove the bolt on the steering knuckle side that secures the upper arm ball joint.

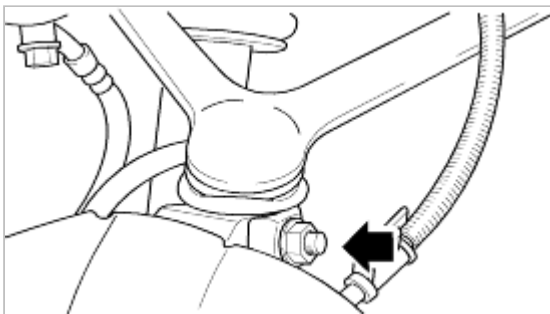

6. Remove the brake hose bracket and then the remove the upper arm bolts and nuts.

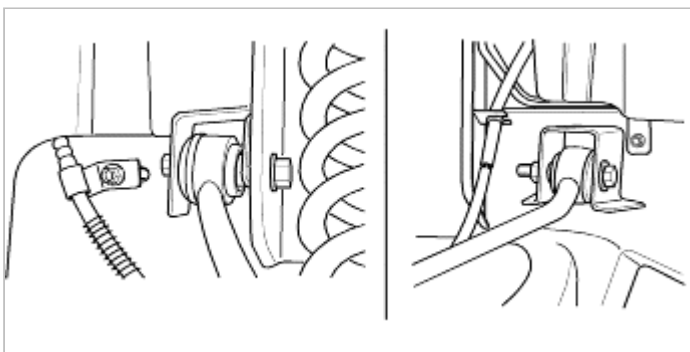

7. Remove the shock absorber lower nut.

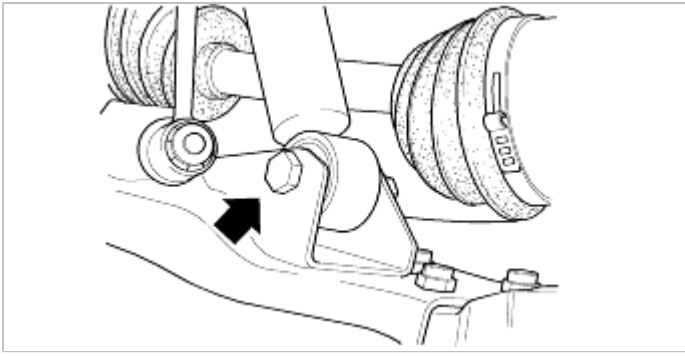

8. Remove the spring and shock absorber assembly from the vehicle as an assembly.

INSTALLATION

1. After making sure identification mark on the spring seat. Position the spring and shock absorber assembly into the upper mounting block.

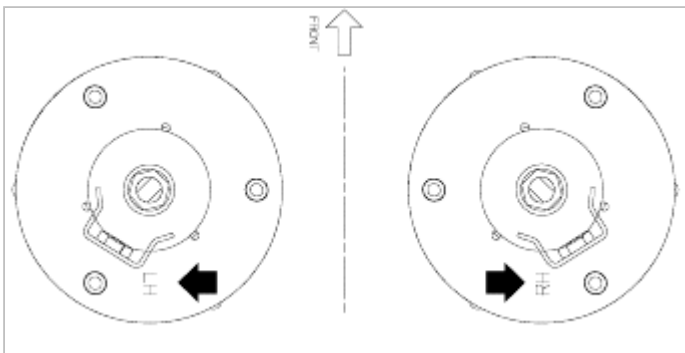

2. Install the mounting block nuts by 3-4 threads only.
3. Insure the front of the vehicle is raised and supported with safety stands.
4. Tighten the lower nut of the shock absorber.

Tightening torque :

122-140 N·m (12.2-14 kg·m, 88-101 lb·ft)

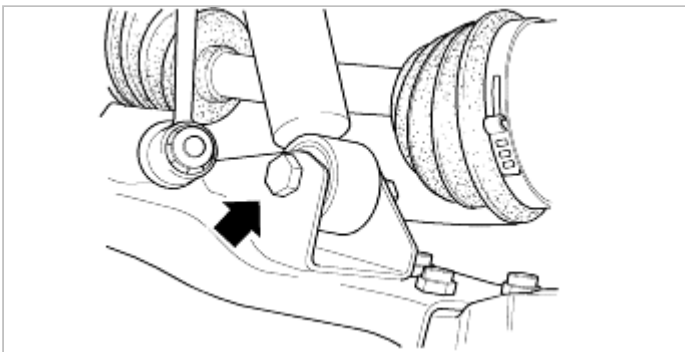

5. Position the upper arm to the frame brackets, insert the bolts and hand tighten the nuts.

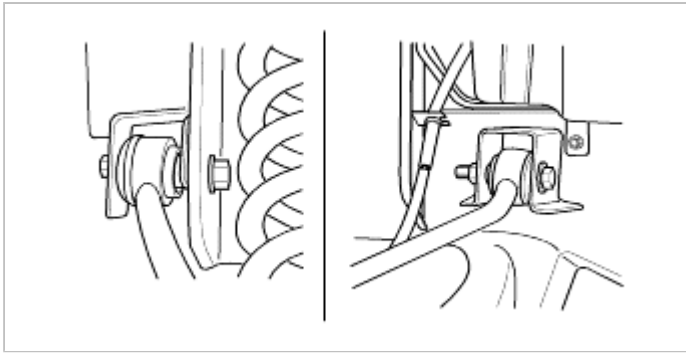

6. Install the upper arm ball joint into the top of the steering knuckle and tighten the side bolt and nut.

Tightening torque :
45-55 N·m (4.4-5.5 kg·m, 31-39 lb·ft)

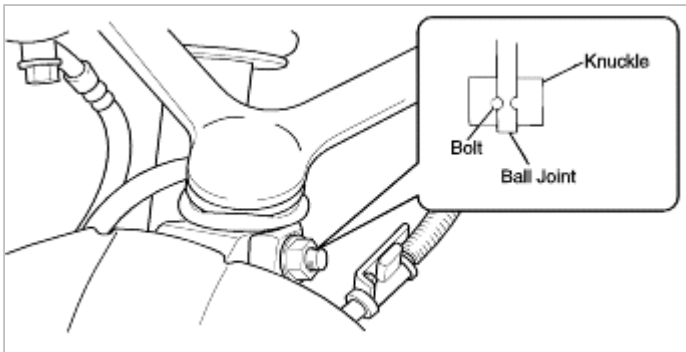

7. Tighten the upper arm bolts and nuts and then install brake hose brackets.

Tightening torque :
76-95 N·m (7.6-9.5 kg·m, 54-68 lb·ft)

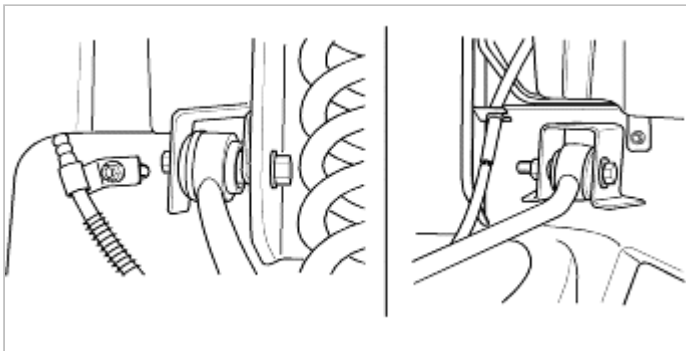

8. Install the wheels and secure with lock nuts.

Tightening torque :
90-120 N·m (9-12 kg·m, 65-86 lb·ft)

9. Lower the vehicle.

10. Tighten the mounting block nut.

Tightening torque :
44-55 N·m (4.4-5.5 kg·m, 31-39 lb·ft)

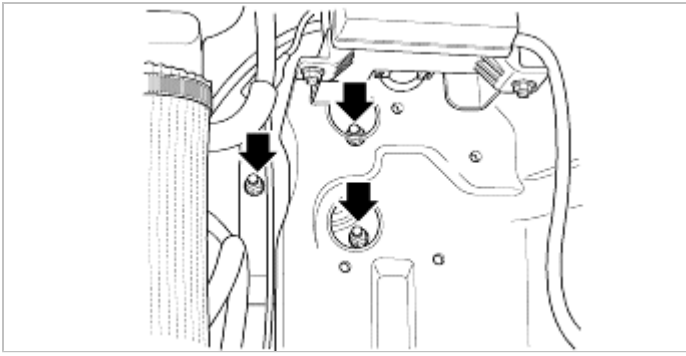

11. Install the battery mounting bracket and the battery.
12. After installing the front shock absorber and coil spring assembly, measure the wheel alignment and adjust if necessary.

DISASSEMBLY

1. Secure the shock absorber in a suitable vise.
2. Loosen the piston rod nut several turns.

NOTICE

- Use copperplate in the jaws of the vise to protect the shock absorber bottom bracket.
- Remove the piston rod nut until coil spring is compressed and secured.

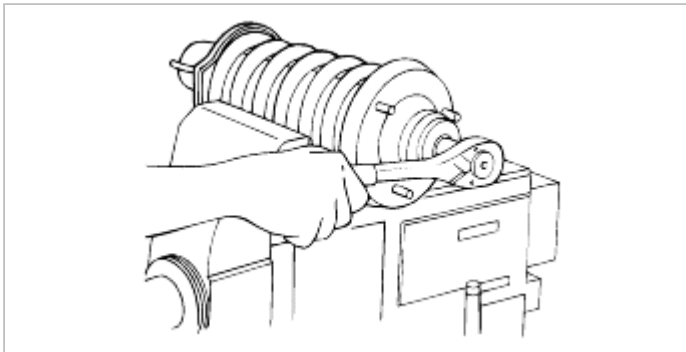

3. While still secured in a vise, compress the coil spring with SST.

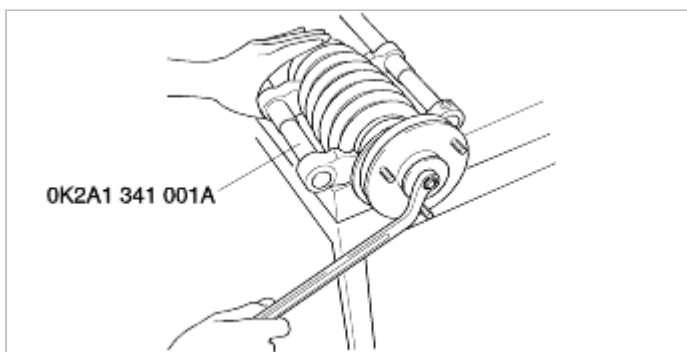

4. Remove the piston rod nut and each part as below.

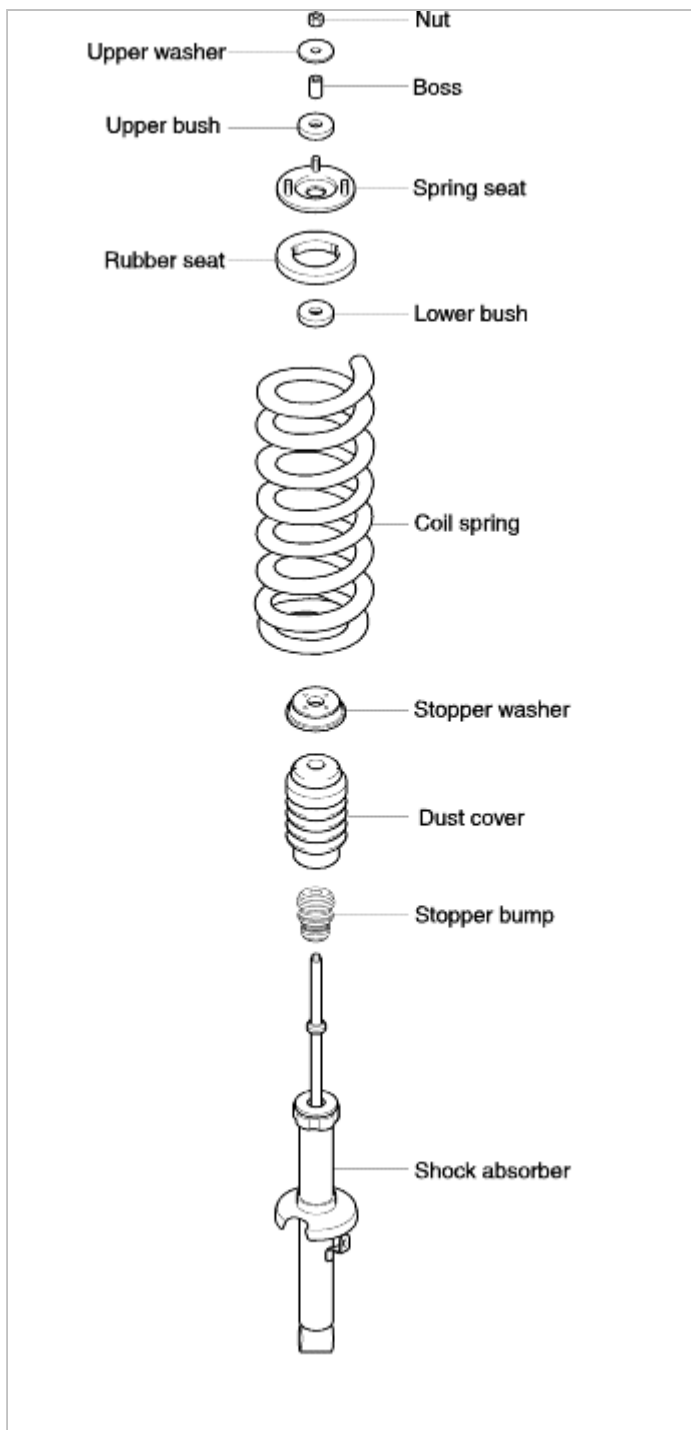

INSPECTION/REBUILD

1. Secure a handle to the shock absorber piston rod and compress and lift the rod three times with a constant speed. Inspect for uniform working force and abnormal noise.

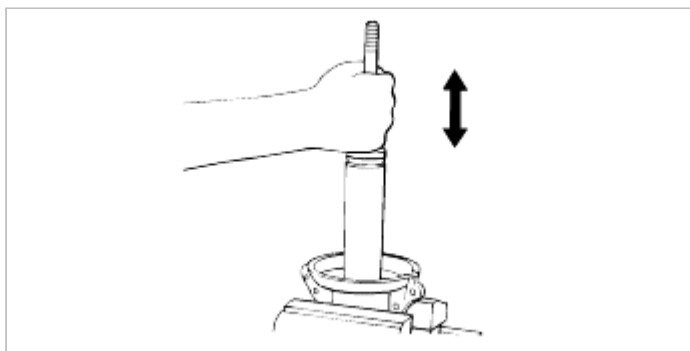

2. Inspect the entire shock absorber for signs of oil leakage; replace if required.
3. Inspect the coil spring for stress cracks and/or other damage.
4. Inspect for damage or deterioration of the upper and lower bushes.
5. Inspect for damage or tearing of the spring seat and rubber seat.

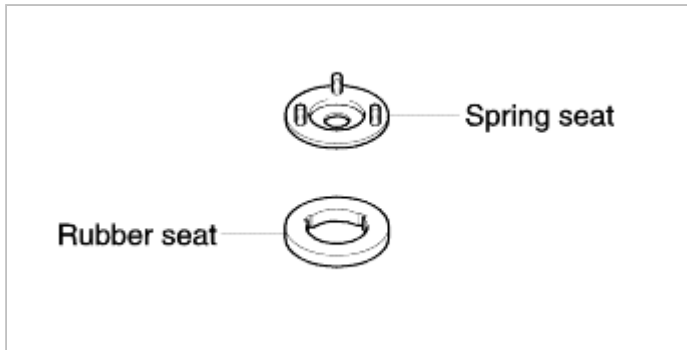

ASSEMBLY

1. Secure the bottom portion of the shock absorber in a vise and compress the coil spring with SST.

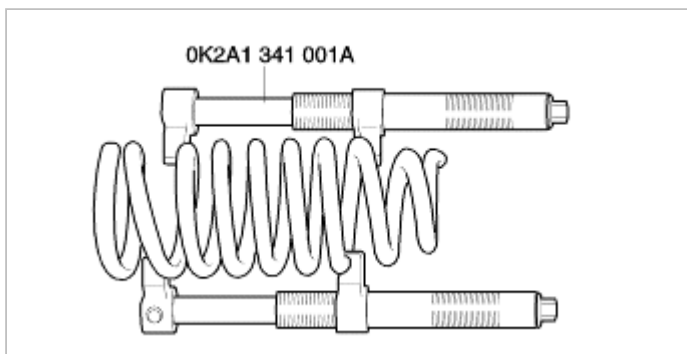

NOTICE

Use copperplate in the jaws of the vise to protect the shock absorber bottom bracket.

2. Set the end of the coil spring to the rubber seat and install the coil spring.
3. Assemble stopper bump, dust cover, stopper washer, lower bush, rubber seat, spring seat, boss, upper bush and upper washer in sequence.
4. Hand tighten the piston rod nut.

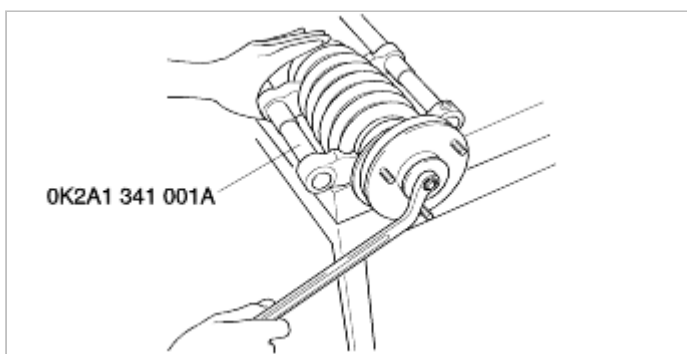

5. Carefully loosen the coil spring compressor and remove it.
6. With the bottom bracket of the shock absorber still in the vice, tighten the piston rod nut.

Tightening torque :
76-95 N·m (7.6-9.5 kg·m, 54-68 lb·ft)

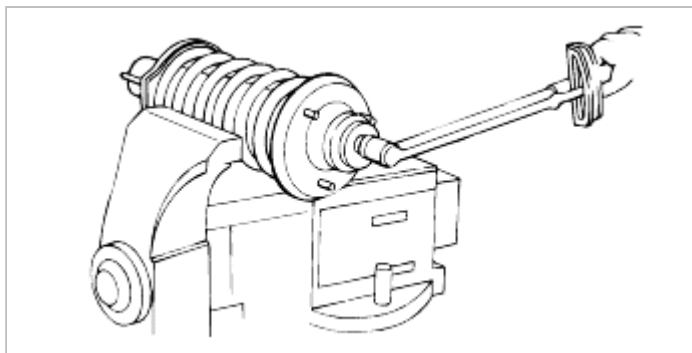

2009 > G 3.3 DOHC >

**REMOVAL**

1. Raise the front of the vehicle and support it with safety stands.
2. Remove the front wheels.
3. Remove the lower nut of control link of stabilizer bar.
4. Remove the lower nut of shock absorber.

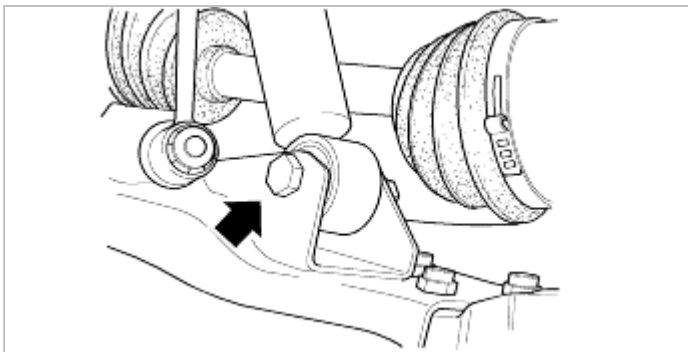

5. Remove the bolts and nuts that joins lower arm and lower arm ball joint.

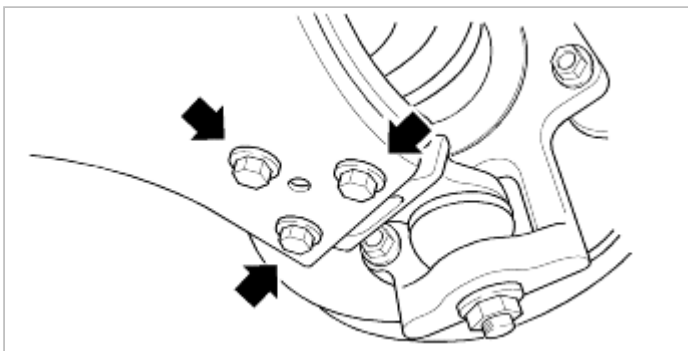

6. Remove the cotter pin and castle nut from the lower arm ball joint.

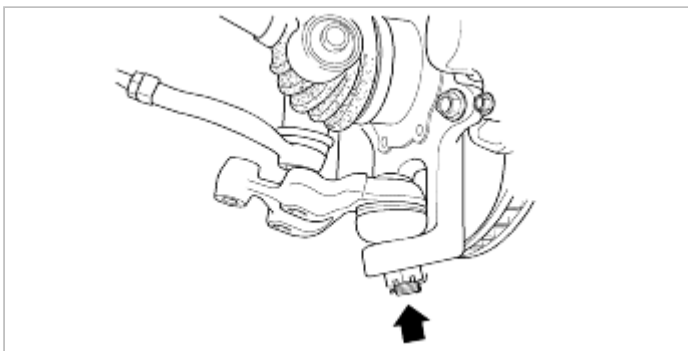

7. Remove the lower arm ball joint from the steering knuckle with SST.
8. Remove the steering gear mounting bolts and nuts.

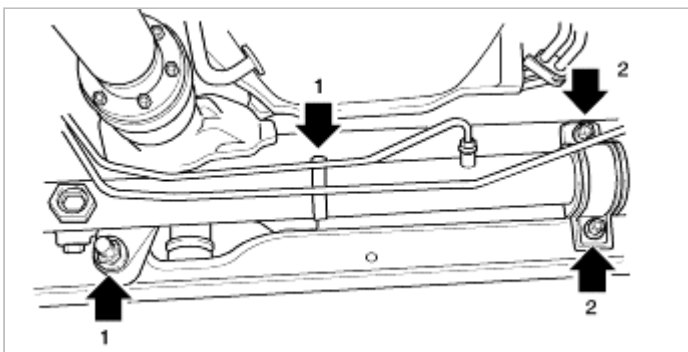

9. Remove the spindle from the front frame crossmember brackets during raising the steering gear box by using suitable bar.

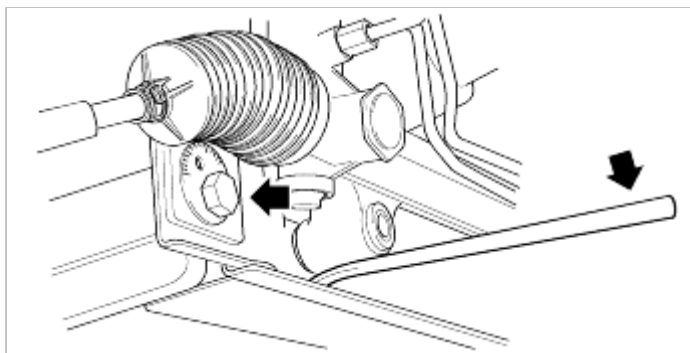
**NOTICE**

Before loosening the nuts of the spindles, make note of the numerical setting and mark the location on the frame bracket and plate so it can be re-installed to the same setting and location.

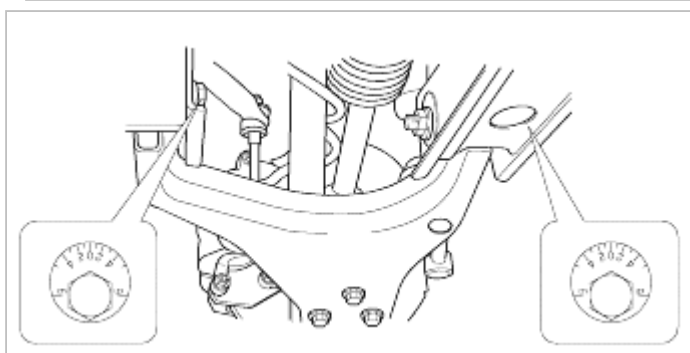

10. Remove the lower arm.

BUSHING REPLACEMENT

1. For bushing removal, utilize a standard bearing press.
2. Install the new bushing using a standard bearing press.

NOTICE

Apply lubricant to the new bushings prior to installation.

INSTALLATION

1. Install the lower arm ball joint to the steering knuckle.

Tightening torque :

160-180 N·m (16-18 kg·m, 115-130 lb·ft)

2. Install a new cotter pin through the castle nut.

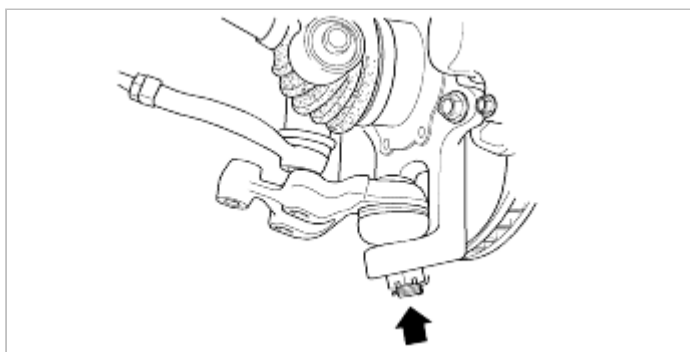

3. Position the lower arm to the front frame crossmember brackets and then position the spindle during lift up the steering gear box by using suitable bar.
4. Install the lower arm spindles.

Tightening torque :

265-305 N·m (26.5-30.5 kg·m, 191-220 lb·ft)

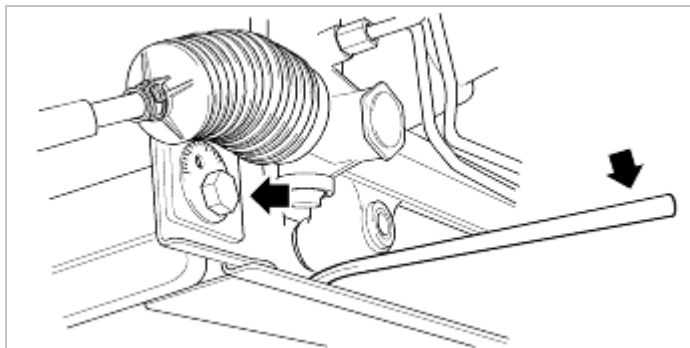

NOTICE

Align the spindle to the numerical setting and marked location on the frame bracket and plate so the same setting and location is maintained.

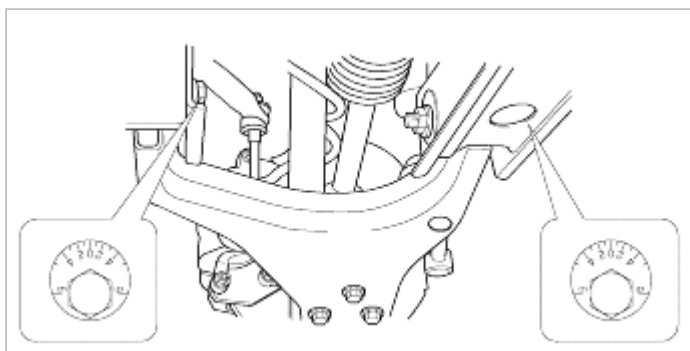

5. Install the lower nut of the shock absorber.

Tightening torque :

122-140 N·m (12.2-14 kg·m, 88-101 lb·ft)

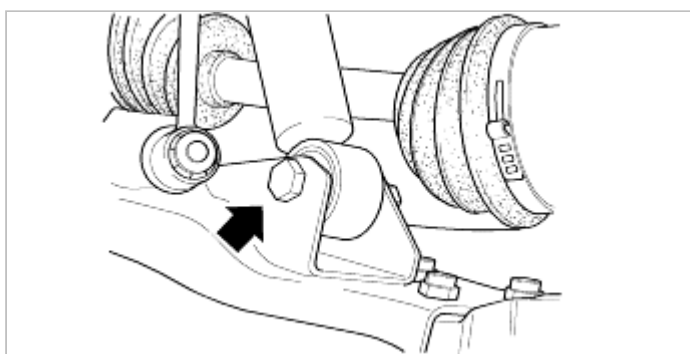

6. Install the lower nut of control link of stabilizer bar.

Tightening torque :

95-117 N·m (9.5-11.7 kg·m, 68-84 lb·ft)

7. Install the wheels and secure the lock nuts.
-

Tightening torque :
90-120 N·m (9-12 kg·m, 65-86 lb·ft)

8. Remove the safety stands and lower the vehicle.

NOTICE

After installation, measure the wheel alignment and adjust if necessary. Refer to "Wheel Alignment" in this section.

INSPECTION

1. Inspect for worn or deteriorated lower arm bushings.
2. Inspect for bent, cracked or damaged lower arm.
3. Inspect for worn or damaged ball joint.
4. Replace if damaged, deformed or cracked; replace bushing if worn or deteriorated. Refer to "Bushing Replacement" in the following procedure.

2009 > G 3.3 DOHC >



REMOVAL

1. Raise the front of the vehicle and support it with safety stands.
2. Remove the front wheels.
3. Remove the bolt on the steering knuckle side that secures the upper arm ball link.

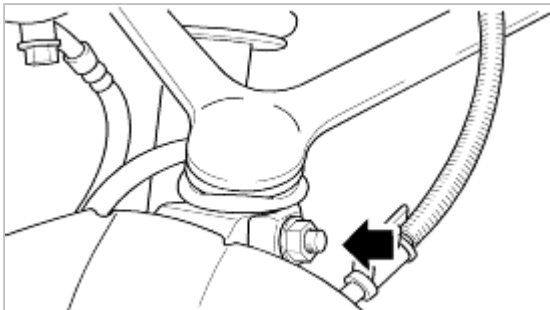

4. Remove the brake hose bracket and then remove the upper arm bolts and nuts.

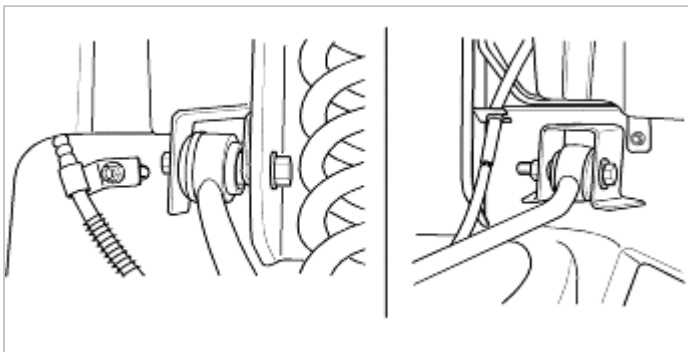

REPLACING THE BUSHING

1. Secure the upper arm in a suitable vise.
2. Using a standard bearing press, remove the old bushing.
3. Install the new bushing and then press it into the upper arm with a standard bearing press.

NOTICE

Apply lubricant to the new bushings to facilitate insertion into the upper arm.
The upper arm ball joint link and dust boot are non-replaceable items. Replace the upper arm if these items are damaged and/or deteriorated.

INSTALLATION

1. Raise the front of the vehicle and support it with safety stands.
2. Position the upper arm to the frame brackets, insert the bolts and hand tighten the nuts.

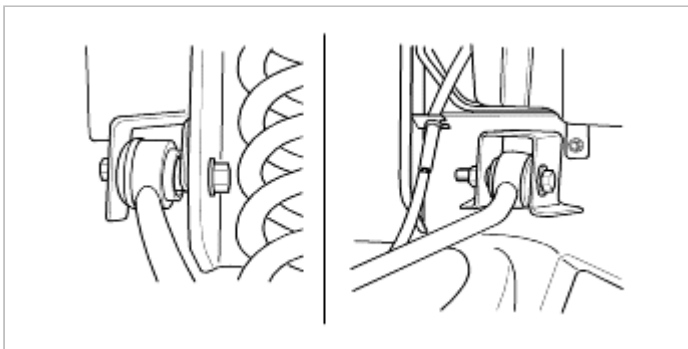

3. Install the upper arm ball joint into the top of the steering knuckle and tighten the side bolt and nut.

Tightening torque :

44-55 N·m (4.4-5.5 kg·m, 31-39 lb·ft)

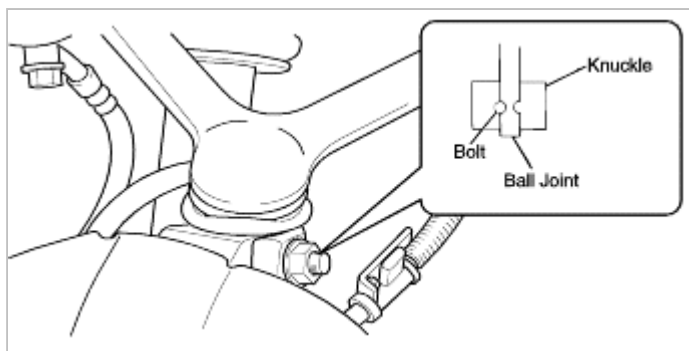

4. Tighten the upper arm bolts and nuts and then install brake hose brackets.

Tightening torque :

76-95 N·m (7.6-9.5 kg·m, 54-68 lb·ft)

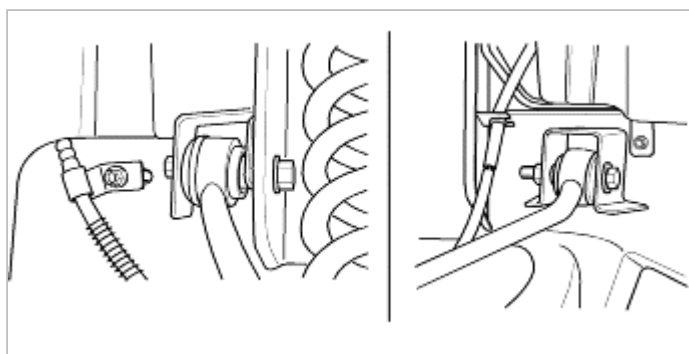

5. Install the wheels and secure with lock nuts.

Tightening torque :

90-120 N·m (9-12 kg·m, 65-86 lb·ft)

NOTICE

After installation, measure the wheel alignment and adjust if necessary. Refer to "Wheel Alignment" in this section.

INSPECTION

1. Inspect for bent, cracked or otherwise damaged upper arm.
2. Inspect for worn or deteriorated upper arm bushing.
3. Inspect for worn or damaged ball link and replace if damaged, deformed or cracked.
4. Replace bushings if worn or deteriorated. Refer to "Replacing the Bushing" in the following procedure.

<https://autolibrary.ir>

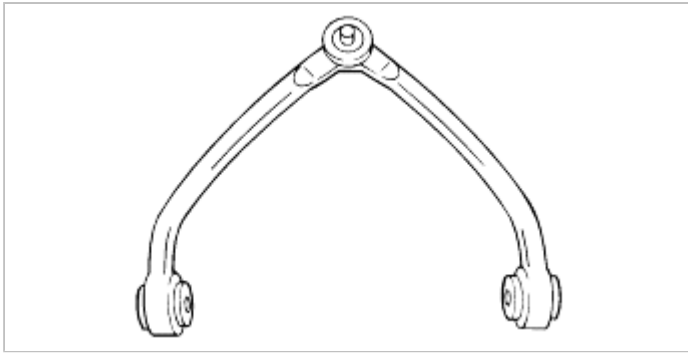

<https://autolibrary.ir>

2009 > G 3.3 DOHC >



REMOVAL

1. Raise up the front of the vehicle and support it with safety stands.
2. Remove the wheels.
3. Remove the undercover.
4. Remove the nuts and oil damper rubbers of control link.

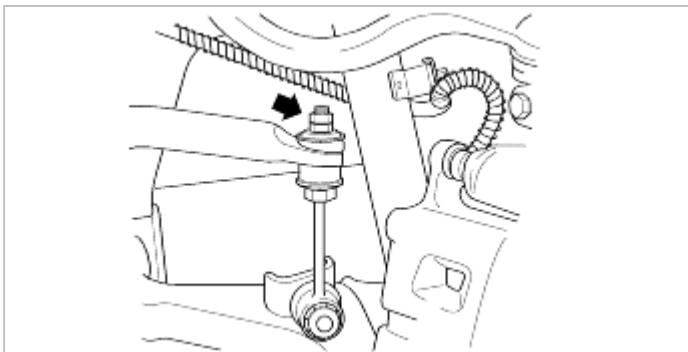

5. Remove the stabilizer bar bushing brackets and then remove the stabilizer bar.

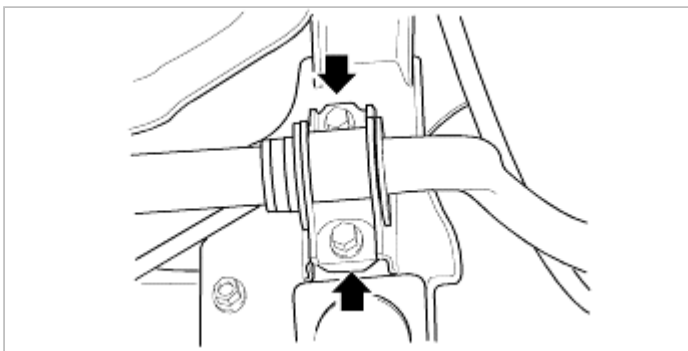

6. Remove the control link from the lower arm.

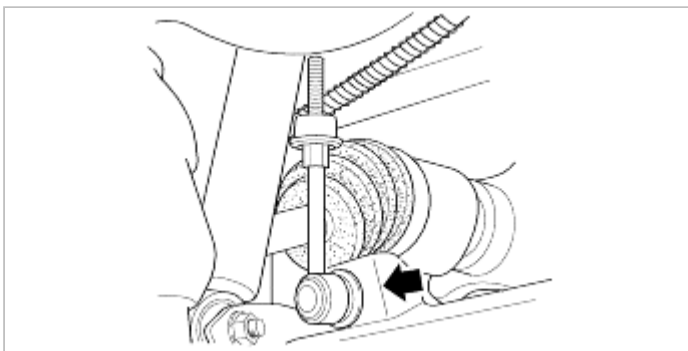

INSTALLATION

1. Position the control links to the lower arm.
2. Loosely tighten the control link nuts.
3. Install the stabilizer bar on the control link.
4. Align the clamp bushing inside of stabilizer bushing and install bracket.

Tightening torque :

44-55 N·m (4.4-5.5 kg·m, 31-39 lb·ft)

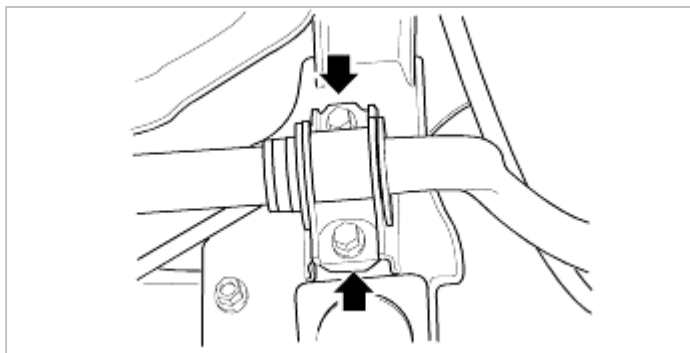

5. Install the oil damper rubber and nut, and then tighten to the specified length.

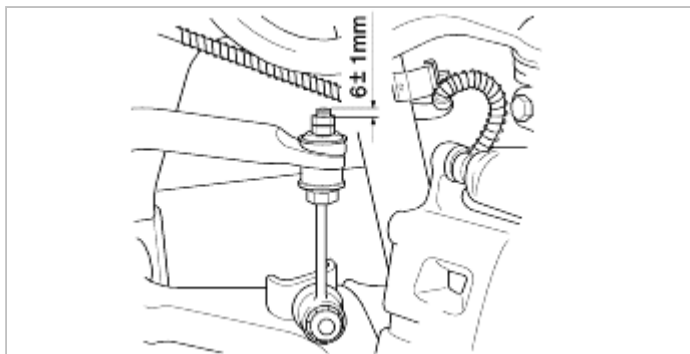

6. Tighten the lower nut of control link.

Tightening torque :

95-117 N·m (9.5-11.7 kg·m, 68-84 lb·ft)

INSPECTION

1. Inspect for bent, cracked or damaged stabilizer bar.
2. Inspect for worn or deteriorated stabilizer bar bushing.

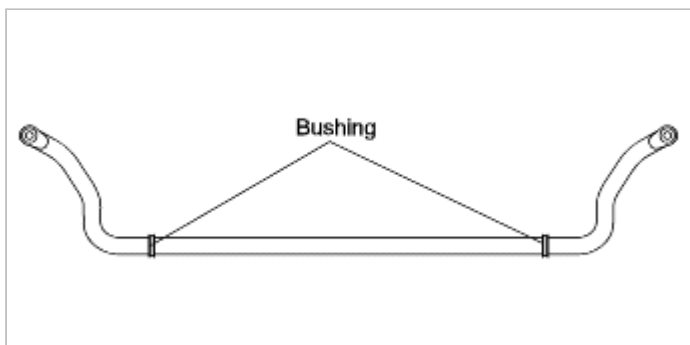

3. Inspect for worn or damaged ball joint of control link.

2009 > G 3.3 DOHC >



REMOVAL

1. Raise the rear of the vehicle and support it with safety stands.
2. Remove the rear wheels.
3. Raise the rear axle housing to facilitate removal of the shock absorbers.

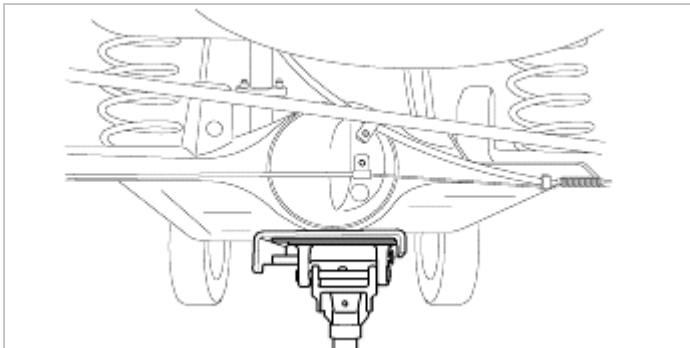

4. Remove stabilizer link upper mounting nut.

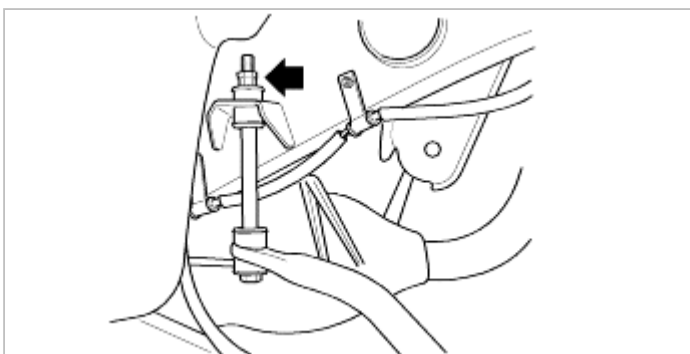

5. Remove the rear shock absorber lower nut and washer.

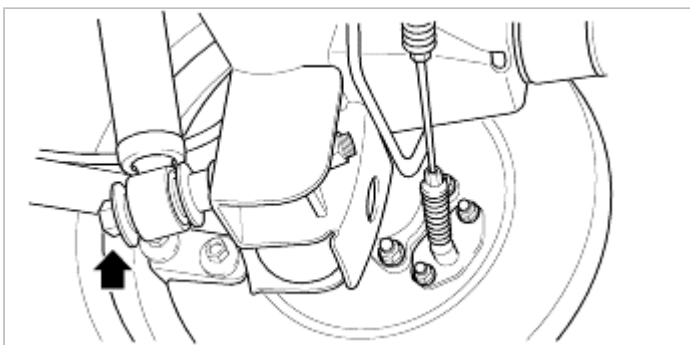

6. Remove the shock absorber upper bolt, and then remove the shock absorber.
7. Lower the rear axle housing slowly to facilitate removal of the coil spring.

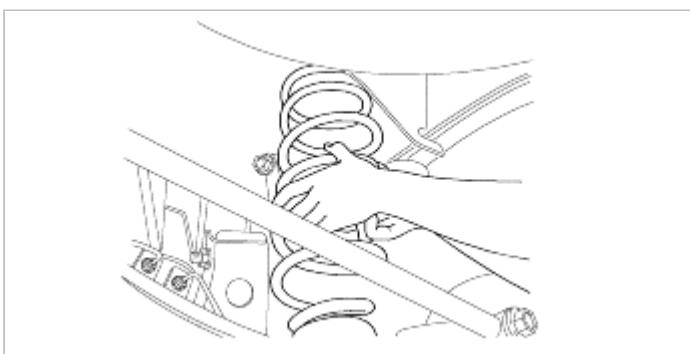

8. Remove the upper rubber seat.

INSTALLATION

1. Position the upper rubber seat to the coil spring.

CAUTION

Align the spring end with the groove of the spring pad and fix the spring and the spring pad by adhering the 3 parts with tape.

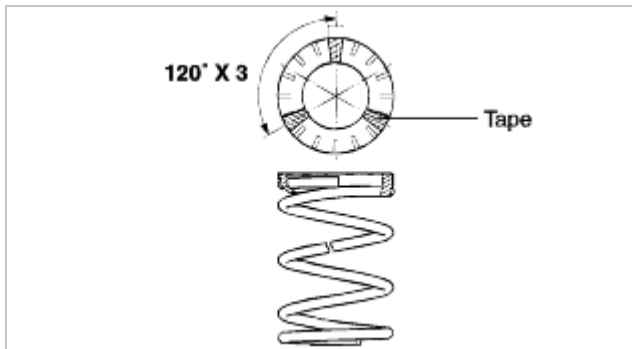

2. Slowly raise the rear axle housing while installing the coil spring.

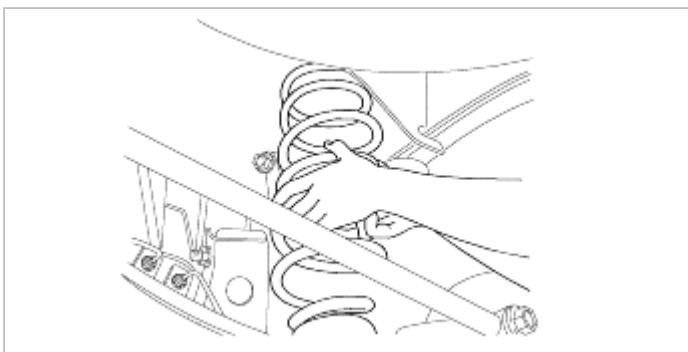

3. Install the shock absorber upper nut.

Tightening torque :
122-140 N·m (12.2-14 kg·m, 88-101 lb·ft)

4. Install the shock absorber lower bolt.

Tightening torque :
122-140 N·m (12.2-14 kg·m, 88-101 lb·ft)

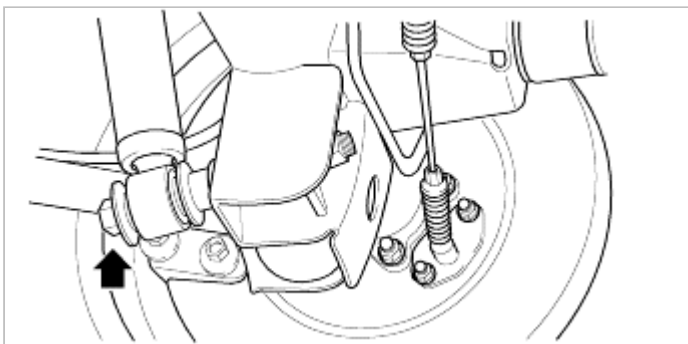

5. Install the stabilizer link upper mounting nut to the specified length.

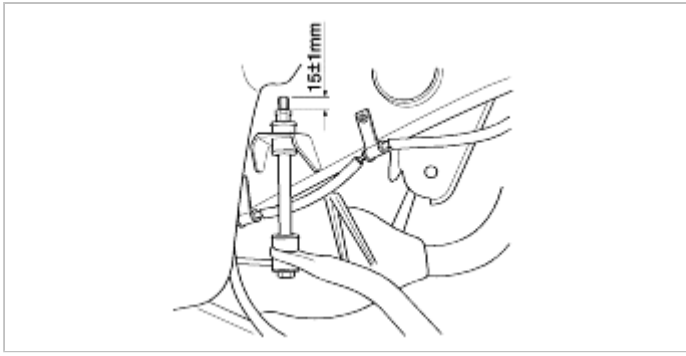

6. Install the wheels and secure with lug nuts.

Tightening torque :

90-120 N·m (9-12 kg·m, 65-86 lb·ft)

7. Remove the safety stands and lower the vehicle.

INSPECTION

1. Compress and expand the shock absorber three to four times and analyze for uniform working force and abnormal noise.
2. Inspect for gas leakage.

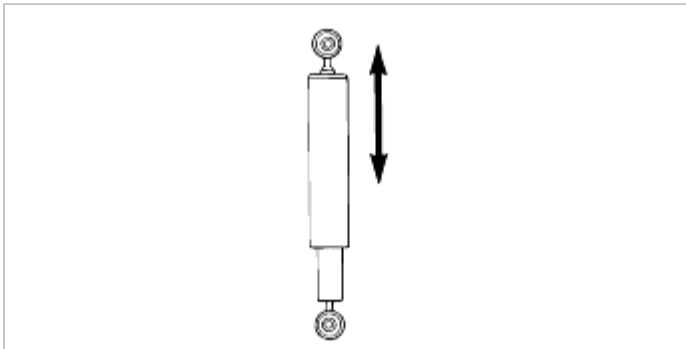

3. Inspect the shock absorber for a worn or deteriorated rubber bushing.
4. Replace the rear shock absorber assembly if a problem is found.
5. Inspect the rear coil spring for bends, cracks or other damage.

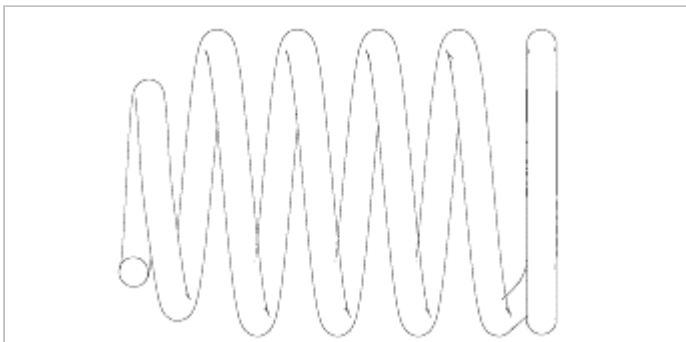

6. Inspect the upper rubber seats for tears and/or deterioration.
7. Inspect the rear jounce stop for damage and/or deterioration.
8. Replace if damaged, deformed or cracked; replace bushings if worn or deteriorated.

2009 > G 3.3 DOHC >



REAR UPPER ARM

Removal

1. Raise the rear of the vehicle and support it with safety stands.
2. Remove the rear wheels.
3. Raise the rear axle housing to facilitate removal of the upper arm.
4. Remove shock absorber lower bolt.

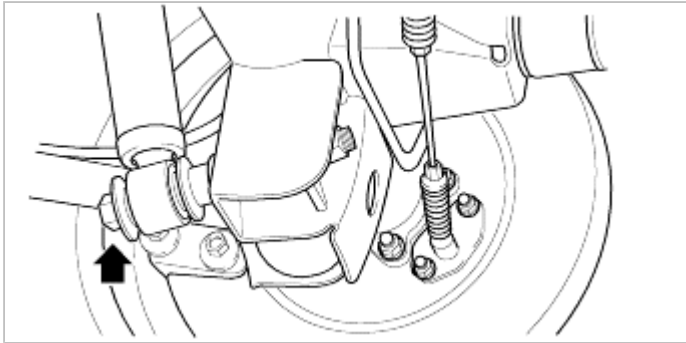

5. Loosen the upper arm bolts and remove the upper arm.

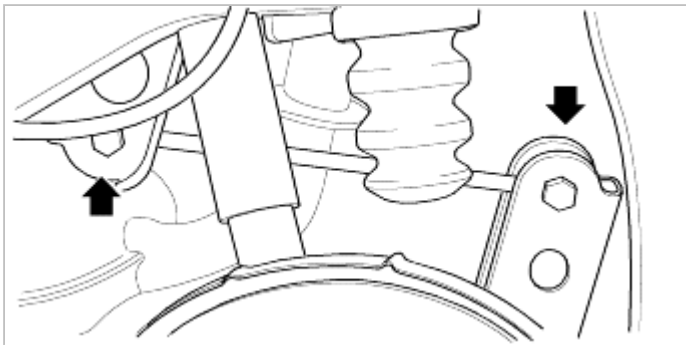

Inspection

1. Inspect the upper arm for bends, cracks and/or other damage.
2. Inspect the upper arm bushings for wear and/or deterioration.
3. Replace if damaged, deformed or cracked; replace bushings if worn or deteriorated. Refer to Bushing Replacement in the following procedure.

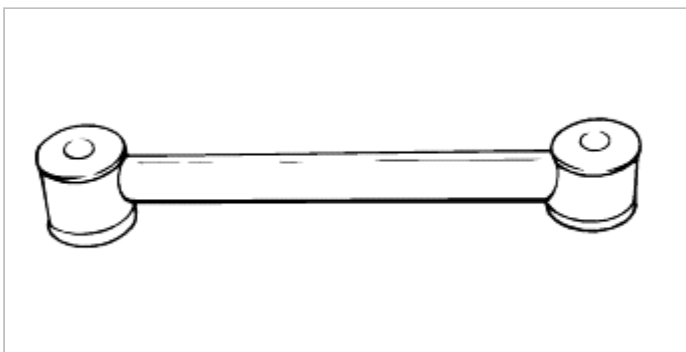

Bushing Replacement

1. Press out the bushing using a standard bearing press.
2. Apply soapy water to the bushing and press into place using a standard bearing press.

Installation

1. Install the upper arm and the bolts.

Tightening torque :
122-140 N·m (12.2-14 kg·m, 88-101 lb·ft)

2. Install shock absorber lower bolt.

Tightening torque :
122-140 N·m (12.2-14 kg·m, 88-101 lb·ft)

3. Lower the rear axle housing.
4. Install the wheels and secure with lug nuts.

Tightening torque :
90-120 N·m (9-12 kg·m, 65-86 lb·ft)

5. Remove the safety stands and lower the vehicle.

REAR LOWER ARM

Removal

1. Raise the rear of the vehicle and support it with safety stands.
2. Remove the rear wheels.
3. Raise the rear axle housing to facilitate removal of the lower arm.
4. Remove shock absorber lower bolt.

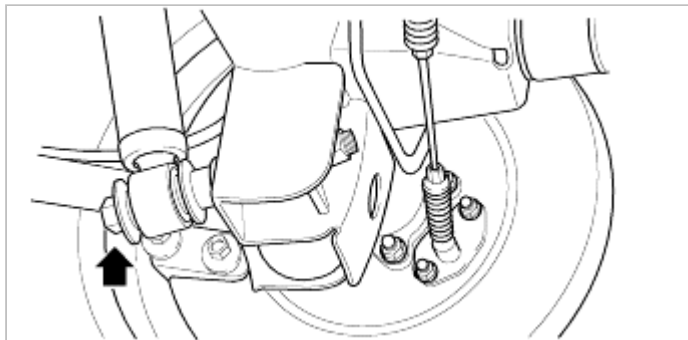

5. Remove wheel speed sensor cable from rear lower arm.
6. Loosen the lower arm bolts and remove the lower arm.

Inspection

1. Inspect the lower arm for bends, cracks and/or other damage.
2. Inspect the lower arm bushings for wear and/or deterioration.
3. Replace if damaged, deformed or cracked; replace bushings if worn or deteriorated. Refer to Bushing Replacement in the following procedure.

Bushing Replacement

1. Press out the bushing using a standard bearing press.
2. Apply lubricant to the bushing and press into place using a standard bearing press.

Installation

1. Install the lower arm and the bolts.

Tightening torque :
122-140 N·m (12.2-14 kg·m, 88-101 lb·ft)

-
2. Install wheel speed sensor cable to the rear lower arm.
 3. Install shock absorber lower bolt.

Tightening torque :
122-140 N·m (12.2-14 kg·m, 88-101 lb·ft)

4. Lower the rear axle housing.
5. Install the wheels and secure with lug nuts.

Tightening torque :
90-120 N·m (9-12 kg·m, 65-86 lb·ft)

6. Remove the safety stands and lower the vehicle.

2009 > G 3.3 DOHC >



REMOVAL

1. Support the bottom of the rear differential carrier with a jack.

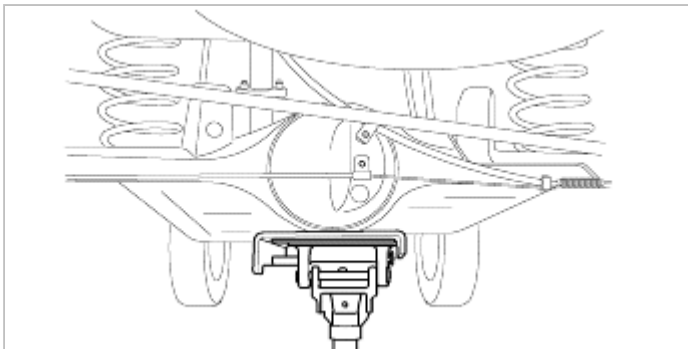

2. Remove the stabilizer link mounting nut.

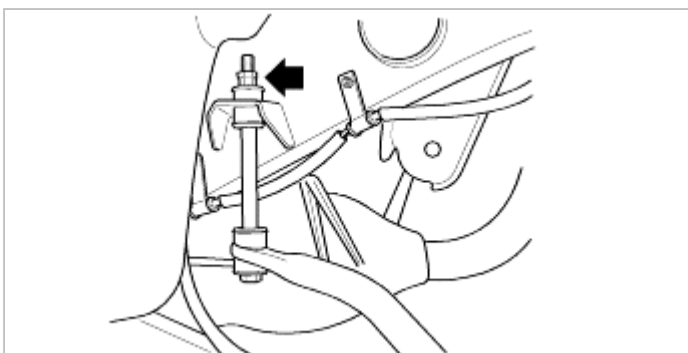

3. Remove the stabilizer bar bushing bracket.

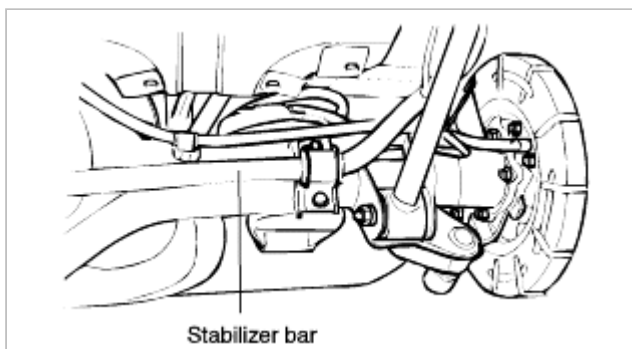

INSTALLATION

1. Align the identification mark white paint on stabilizer bar with bushing and install the stabilizer bar bushing bracket.

Tightening torque :

19-23N·m (1.9-2.3 kg·m, 13-16lb·ft)

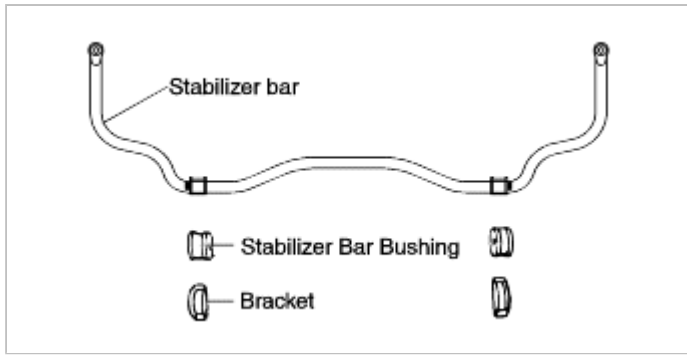

2. Install the joint cup and nut and then tighten to the specified length.

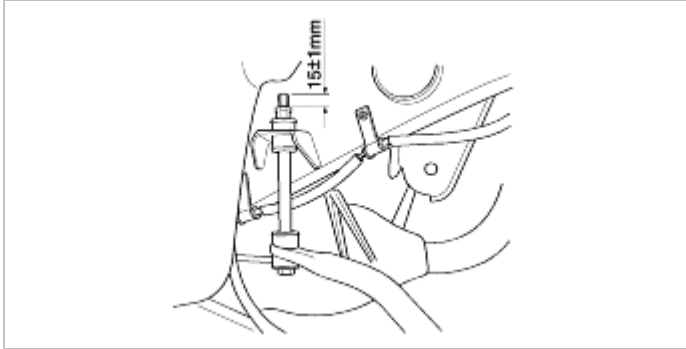

2009 > G 3.3 DOHC >



LATERAL ROD

Removal

1. Raise the rear of the vehicle and support it with safety stands.
2. Remove the rear wheels.
3. Raise the rear axle housing to facilitate removal of the lateral rod.
4. Remove shock absorber lower bolt.

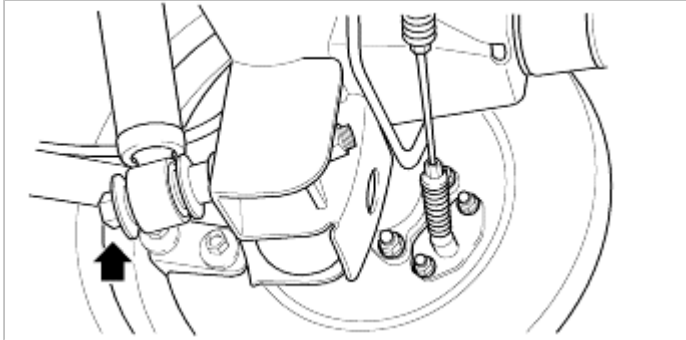

5. Loosen the lateral rod bolts and remove the lateral rod.

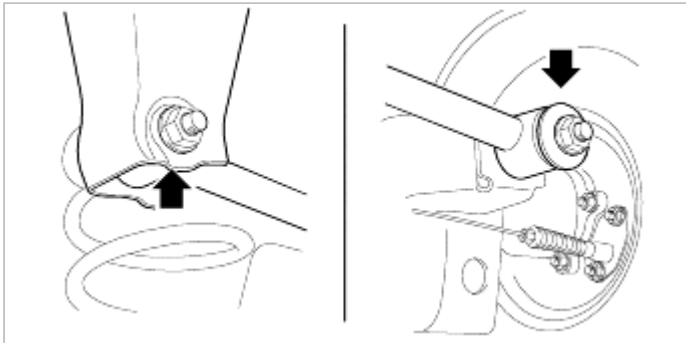

Inspection

1. Inspect the lateral rod for bends, cracks and/or other damage.



2. Inspect the lateral rod bushings for wear and/or deterioration.
3. Replace if damaged, deformed or cracked; replace bushings if worn or deteriorated. Refer to "Bushing Replacement" in the following procedure.

Bushing Replacement

1. Press out the bushing using a standard bearing press.
2. Apply lubricant to the bushing and press into place using a standard bearing press.

Installation

1. Install the lateral rod and the bolts.

Tightening torque :
187-215 N·m (18.7-21.5 kg·m, 135-155 lb·ft)

2. Install shock absorber lower bolt.

Tightening torque :
122-140 N·m (12.2-14.0 kg·m, 88-101 lb·ft)

3. Lower the rear axle housing.
4. Install the wheels and secure with lug nuts.

Tightening torque :
90-120 N·m (9-12 kg·m, 65-86 lb·ft)

5. Remove the safety stands and lower the vehicle.



FRONT WHEEL ALIGNMENT

WARNING

PROVIDE SUFFICIENT SUPPORT FOR THE VEHICLE TO REDUCE THE POSSIBILITY OF THE VEHICLE FALLING, CAUSING PERSONAL INJURY OR DEATH.

Wheel alignment refers to the angular relationship between the wheels, control arms, suspension and the ground. It deals with tire camber, caster, toe-in and wheel balancing. Proper wheel alignment and wheel balance insures a safe, quiet ride with minimal tire wear. This section assumes that all components are in good working condition. Performing this exercise may also detect any problem areas in the front suspension. It is advisable to replace defective components before attempting a wheel alignment.

Inspection

1. Inspect tires for proper balance and inflation. Balance tires and set to the recommended pressure if necessary.
2. Inspect front wheel bearing play and reduce the bearing play; replace any defective bearings.
3. Inspect for any excessive looseness of the ball joints and steering center link.
4. Place the vehicle on level ground and confirm that there are no passengers or luggage on board.
5. Push down on the front of the vehicle to determine the correct operation of the shock absorbers.

CAMBER

Inspection (Camber)

1. Position the vehicle so that the front wheel is on the turning-radius gauge.
2. Remove wheel cover.
3. Attach the standard camber gauge to the hub and measure the camber.

Camber :

0.39 ± 0.5° (No Passenger Load)

0° (2 Passenger Load)

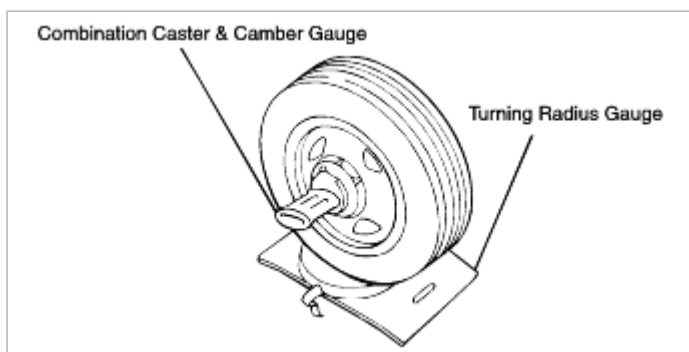

Adjustment (Camber)

1. Turn the front spindle clockwise so that the number "1" mark is aligned with the vertical line on the spindle bracket.
2. Turn the rear spindle clockwise so that the number "1" mark is aligned with the vertical line on the spindle bracket.

Each numerical point indicated on the spindle increases the camber by 0.18 degrees when turned to the vertical line on the spindle bracket.

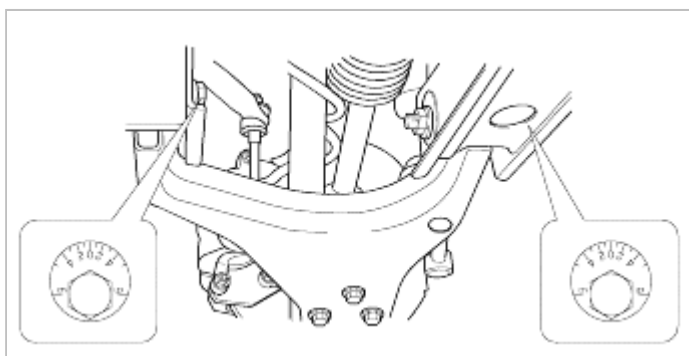

CASTER

Inspection (Caster)

1. Position the vehicle so that the front wheel is on the turning-radius gauge.
2. Remove the wheel cover.

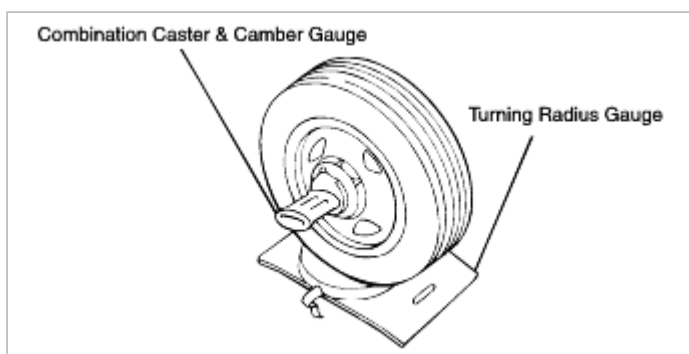

3. Attach a standard caster gauge to the hub and measure the caster.

Caster :

3.30° ± 0.5° (No Passenger Load)

3.55° (2 Passenger Load)

Adjustment (Caster)

1. Turn the front spindle clockwise until the number "1" mark is aligned with the vertical line on the spindle bracket.
2. Turn the rear spindle counter-clockwise until the number "1" mark is aligned with the vertical line on the spindle bracket.

Each numerical point indicated on the spindle increases the caster by 0.23 degrees when turned to the vertical line.

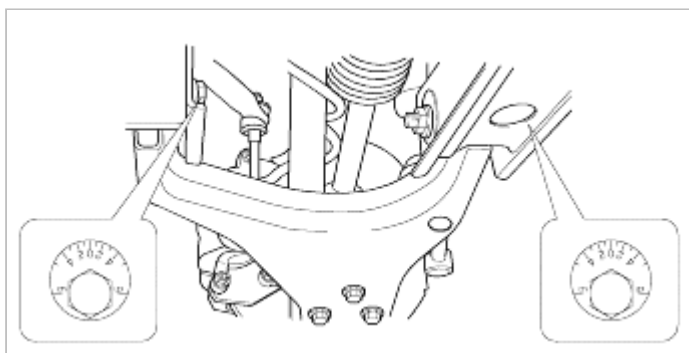

TOE-IN

INSPECTION (TOE-IN)

1. Position the vehicle on level ground and place the front wheels in a straight-ahead position within ± 5 degrees.

2. Measure the toe-in with a standard toe-in gauge.

Toe-in (B-A) :

$0^\circ \pm 0.2^\circ (0 \pm 0.079 \text{ in.})$

(No Passenger Load)

0 in. (0°)

(2 Passenger Load)

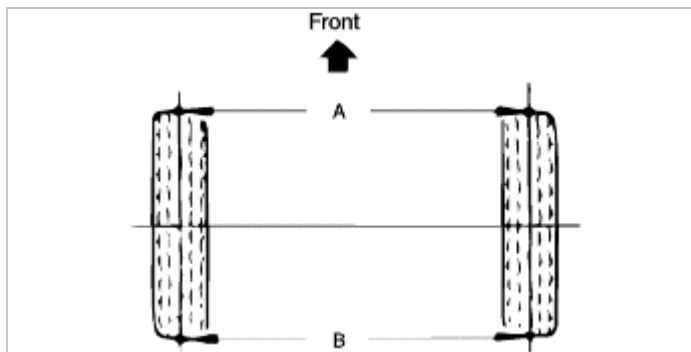

ADJUSTMENT (TOE-IN)

1. Loosen the left and right tie-rod lock nuts.
2. Toe to specifications by turning the tie-rod by the center adjuster.
3. Tighten the left and right tie-rod lock nuts.

Tightening torque :

50-55 N·m (5.0-5.5 kg·m, 36-39 lb·ft)

4. Repeat adjustment instructions for opposite side.

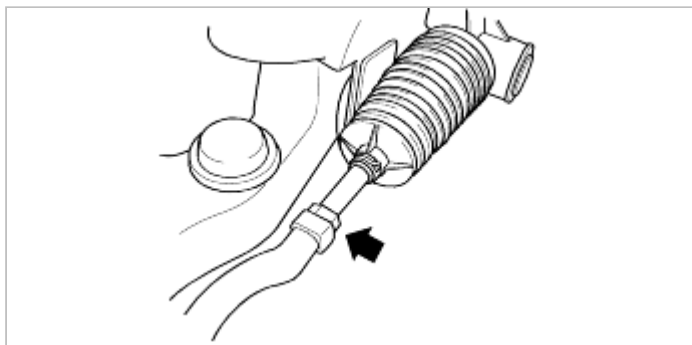

2009 > G 3.3 DOHC >



TIRE WEAR

1. Measure the tread depth of the tire.

Tread depth of tire (Limit) :
1.6 mm (0.0630 in.)

2. If the tread depth is less than the limit, replace the tire.

NOTICE

When the tread depth of the tire is reduced to 1.6 mm(0.0630 in.) or less, the wear indicators will appear.

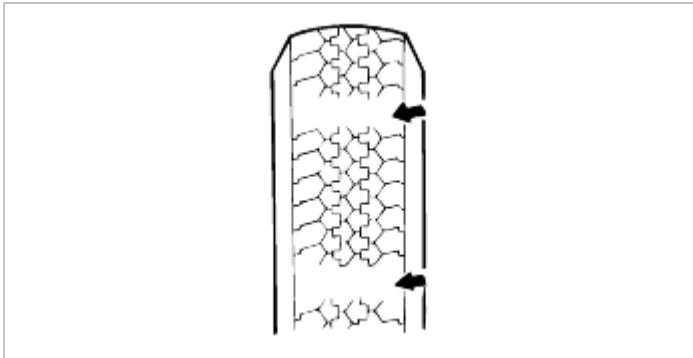

2009 > G 3.3 DOHC >



WHEEL RUNOUT

1. Jack up the vehicle and support it with jack stands.
2. Measure wheel runout with a dial indicator.
3. Replace the wheel if wheel runout exceeds the limit.

Wheel runout [Limit]

Direction	Aluminum wheel	Steel wheel
Radial	0.3 mm (0.012 in.)	1.0 mm (0.039 in.)
Axial	0.3 mm (0.012 in.)	1.2 mm (0.222 in.)

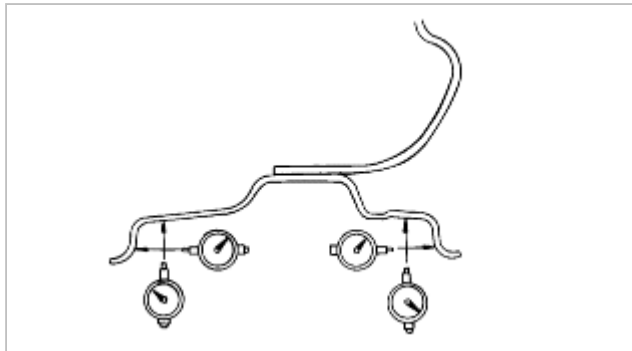

WHEEL NUT TIGHTENING

1. Tightening torque.

Tightening torque :

90-120 N·m (9-12 kg·m, 65-86 lb·ft)

CAUTION

When using an impact-wrench, adjust the tightening torque completely.

2. Tighten all the wheel nut according to the order shown in the illustration until they are all tight.

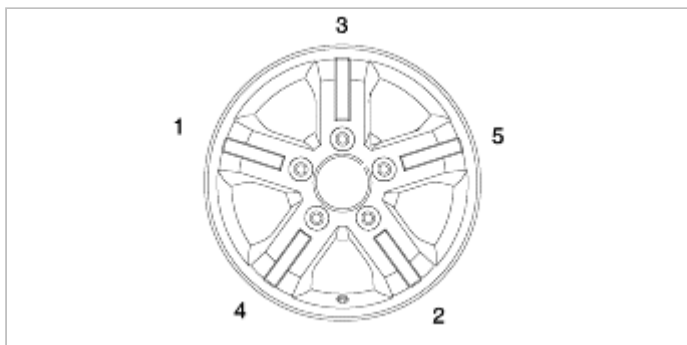

2009 > G 3.3 DOHC >

**SPECIFICATION****PROPELLER SHAFT**

Items		Specification	
Joint type	Front	UJ + UJ	
	Rear	UJ + UJ	
Length X O.D. (mm(in))	Front(4WD)	Diesel 2.5 VGT A/T	675 X 63.5 (26.57 X 2.50) (Blue)
		Diesel 2.5 VGT M/T	640.8 X 63.5 (25.23 X 2.50) (Green)
		Diesel 2.5 WGT A/T, M/T	660.4 X 63.5 (26.00 X 2.50) (Yellow)
		Gasoline 3.3/3.8 A/T	625.5 X 63.5 (24.63 X 2.50) (Silver)
	Rear(4WD)	Diesel 2.5 VGT A/T	1123 X 76.2 (44.21 X 3.00) (Blue)
		Diesel 2.5 VGT M/T	1156 X 76.2 (45.51 X 3.00) (Green)
		Diesel 2.5 WGT A/T, M/T	1137 X 76.2 (44.76 X 3.00) (Yellow)
		Gasoline 3.3/3.8 A/T	1172 X 76.2 (46.14 X 3.00) (Silver)
	Rear(2WD)	Diesel 2.5 VGT A/T	1462.8 X 76.2 (57.59 X 3.00) (Green)
		Diesel 2.5 WGT A/T	1476 X 76.2 (58.11 X 3.00) (Blue)
		Diesel 2.5 WGT M/T	1496 X 76.2 (58.90 X 3.00) (Yellow)
		Gasoline 3.3/3.8 A/T	1531.6 X 76.2 (60.30 X 3.00) (Silver)
Run-out (mm(in))		0.3 (0.01)	

UJ : Universal Joint

O.D. : Outer Diameter

FRONT AXLE AND DRIVESHAFT

Items		Specification	
Front axle hub bearing type		Double taper roller bearing	
Driveshaft joint type (4WD)	Outer	BJ	
	Inner	TSJ	
Differential (4WD)	Reduction gear type		Hypoid gear
	Reduction ratio	Diesel 2.5 WGT M/T	4.181 (White)
		Diesel 2.5 VGT M/T	3.727 (Red)
		Diesel 2.5 WGT A/T Diesel 2.5 VGT A/T	3.333 (Green)

		Gasoline 3.3/3.8 A/T	3.333 (Green)
--	--	----------------------	---------------

BJ : Birfield Joint, TSJ : Three Spherical Joint

REAR AXLE AND AXLE SHAFT







Items		Specification	
Axle housing type		Banjo type	
Axle shaft supporting type		Semi-floating type	
Differential	Reduction gear type		Hypoid gear
	Reduction ratio	Diesel 2.5 WGT M/T	4.181 (White)
		Diesel 2.5 VGT M/T	3.727 (Red)
		Diesel 2.5 WGT A/T Diesel 2.5 VGT A/T	3.333 (Green)
		Gasoline 3.3/3.8 A/T	3.333 (Green)

LUBRICANTS

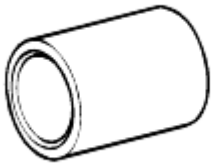

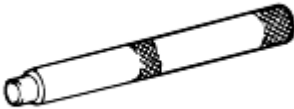

Items		Specification	Quantity
Driveshaft	BJ Boot grease	Repair kit grease	210g
	TSJ Boot grease	Repair kit grease	150g
Differential	Hypoid gear oil	SAE90, API GL-5 (MOBIL : MOBIL LUBE HD, SHELL : SHELL SPIRAX HD)	(Fill the reservoir to the plug hole) Front : 1.3L Rear : 1.6L
	LSD oil	SAE 85W-90, API GL-5 (MOBIL : INFILREX 33, SK : G-LS)	

2009 > G 3.3 DOHC >

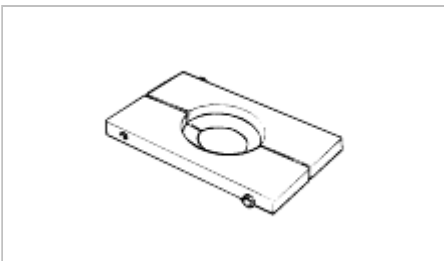
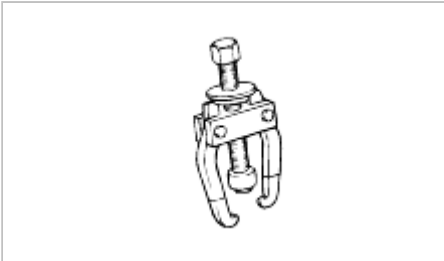
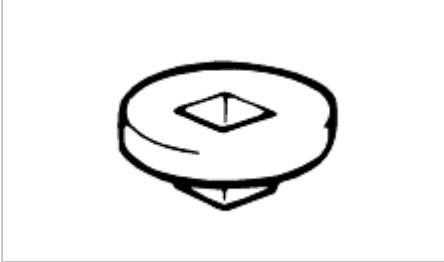
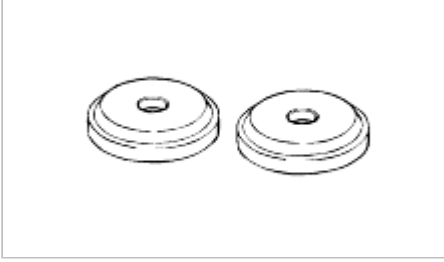
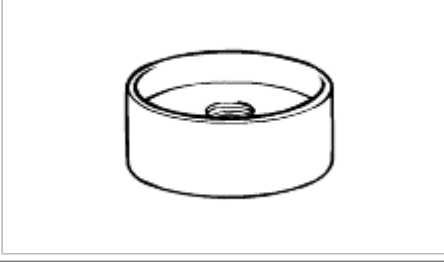
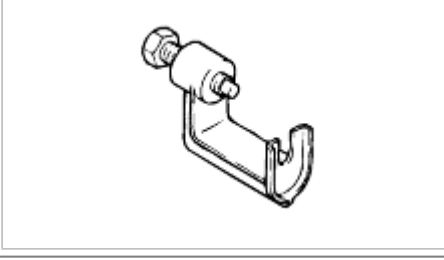
**SPECIAL TOOL**

Tool (Number and Name)	Illustration	Use
Bushing remover and installer 09216-21100		Press-fitting of the inner shaft housing dust seal
Bearing outer race installer 09432-33700		Installation of the front hub bearing (Use with 09500-21000)
Bar 09500-21000		Installation of the front hub bearing (Use with 09432-33700)
Draft 09517-21400		Removal of the outer race from the carrier
Universal joint remover 09493-43000		Removal and installation of the journal bearing
Oil seal installer 09517-21000		Press-fitting of the differential drive pinion oil seal (Use with 09500-21000)
Remove plate		Removal of the differential drive

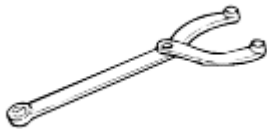
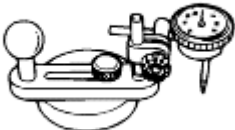
09527-4A000		pinion inner bearing
Bearing puller 09517-43001		<ul style="list-style-type: none"> • Removal of the front lower arm ball joint • Removal of the differential side bearing
Preload socket 09532-11600		Measurement of the drive pinion starting torque (Use with torque wrench)
Oil seal installer 09532-32000		Installation of the differential drive pinion front bearing outer race
Oil seal installer 09542-4A000		Press-fitting of the oil seal into knuckle (Use with 09500-11000)
Ball joint remover 0K670 321 019		Disconnection of the tie rod ball joint
Oil seal installer 09532-32100B		Installation of the differential drive pinion rear bearing outer race (Use with 09500-11000)

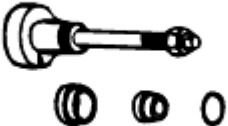
		
Working base 09517-43401		Supporting for the differential carrier
End yoke holder 09517-21700		Removal and installation of the differential self-locking nut
Drive pinion 0K993 270 A09		For adjusting height of drive pinion
Gauge block 0K993 270 A08		
Drive pinion model 0K993 270 A10		
Adjusting nut wrench 0K993 270 014		For adjusting screw disassembly

<https://autolibrary.ir>

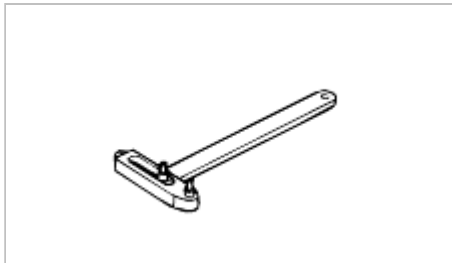
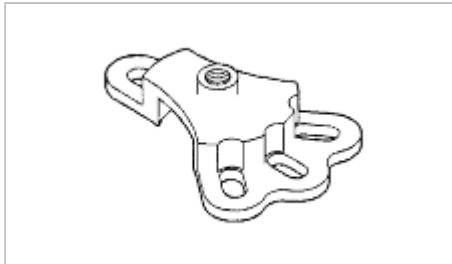
		
<p>LSD test adapter 09530-FM000</p>		<p>For testing of LSD performance.</p>

<https://autolibrary.ir>

2009 > G 3.3 DOHC >



TROUBLESHOOTING

Symptom		Probable cause	Remedy
Propeller shaft	Noise at start	Worn journal bearing	Replace
		Worn sleeve yoke spline or flange yoke	Replace
		Loose propeller shaft installation	Retighten
	Noise and vibration at high speed	Unbalanced propeller shaft	Replace
		Improper snap ring selection	Adjust the clearance
		Worn journal bearing	Replace
Drive shaft, Inner shaft	Noise during wheel rotation	Housing tube bent	Replace
		Inner shaft bent	
		Inner shaft bearing worn, pounding	Replace
		Drive shaft assembly worn damaged, bent	Check or replace
	Noise due to excessive play of wheel in turning direction	Inner shaft and side gear serration play	Replace
		Drive shaft and side gear serration play	
Axle shaft, axle housing	Noise while wheels are rotating	Bent axle shaft	Replace
		Worn or scarred axle shaft bearing	Replace
	Grease leakage	Worn or damaged oil seal	Replace
		Malfunction of bearing seal	Replace
Differential	Constant noise	Improper drive gear and drive pinion gear tooth contact	Correct or replace
		Loose, worn or damaged side bearing	
		Loose, worn or damaged drive pinion bearing	
		Worn drive gear, drive pinion	
		Worn side gear thrust washer or pinion shaft	
		Deformed drive gear of differential case	
		Damaged gear	
		Foreign material	
	Insufficient oil	Replenish	
Differential	Gear noise while driving	Poor gear engagement	Correct or replace
		Improper gear adjustment	
		Improper drive pinion preload adjustment	
		Damaged gear	Replace
		Foreign material	Eliminate the foreign material and check (Replace the parts if necessary)

	Insufficient oil	Replenish
Gear noise while coasting	Improper drive pinion preload adjustment	Correct or replace
	Damaged gear	Replace
Bearing noise while driving or coasting	Cracked or damaged drive pinion rear bearing	Replace
Noise while turning	Loose side bearing	Replace
	Damaged side gear, pinion gear or pinion shaft	
Heat	Improper gear backlash	Adjust
	Excessive preload	
	Insufficient oil	Replenish
Oil leakage	Differential carrier not tightened	Retighten, apply sealant, or replace the gasket
	Seal malfunction	
	Worn or damaged oil seal	Replace
	Excessive oil	Adjust the oil level

2009 > G 3.3 DOHC >



COMPONENTS (T.S.J.-B.J.)

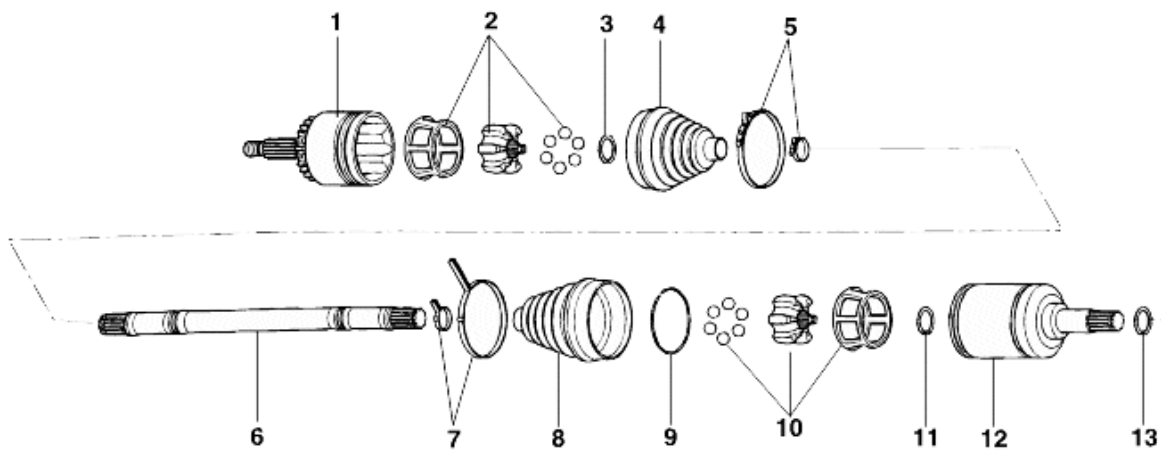

- | | |
|----------------------------|-------------------------------|
| 1. B.J assembly | 7. T.S.J boot band |
| 2. B.J inner race and ball | 8. T.S.J boot |
| 3. Snap ring | 9. Clip |
| 4. B.J boot | 10. T.S.J inner race and ball |
| 5. B.J boot band | 11. Snap ring |
| 6. Drive shaft | 12. T.S.J assembly |
| | 13. Clip |

REPAIR KIT

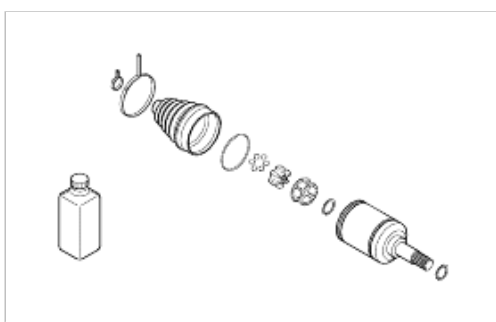
Kit name	Illustration	Components
T.S.J boot kit		<ul style="list-style-type: none"> • T.S.J boot band • T.S.J boot • Snap ring • Spider assembly • Snap ring • T.S.J assembly • Clip • Grease
B.J boot kit		<ul style="list-style-type: none"> • B.J assembly • B.J inner race and ball • Snap ring • B.J boot • B.J boot band • Grease

2009 > G 3.3 DOHC >

**INSPECTION**

1. Inspect for torn or loose CV joint boots.

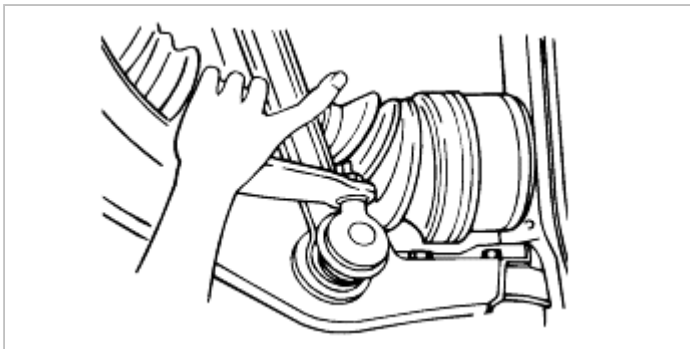

2. Test for loose drive shaft splines. By grasping the drive shaft and tugging up and down and fore and aft.
3. Also inspect for bent or broken drive shaft.

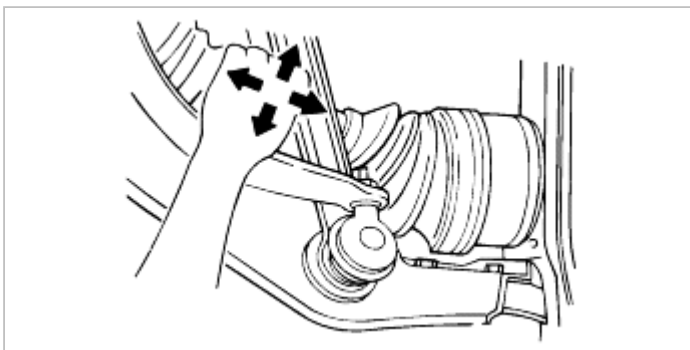
**REMOVAL (HALFSHAFTS)**

1. Remove the lock nut from front hub.

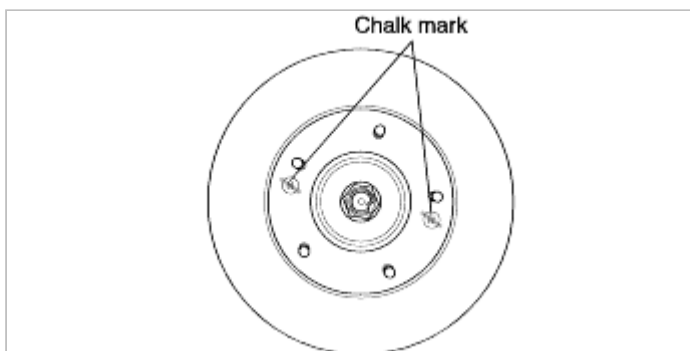

2. Remove the upper control arm link lock bolt, spring washer and nut.

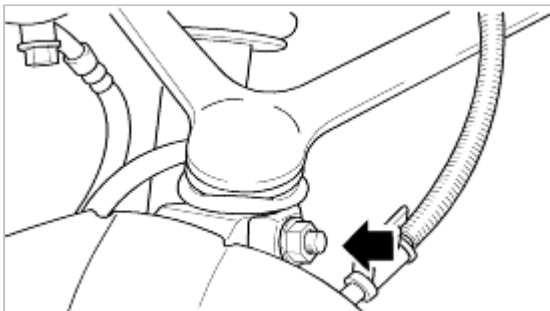

3. Remove tie rod end cotter pin and using a ball joint puller, remove tie rod end from steering knuckle.



4. Mark drive shaft for identical installation position.
5. Using tool, pry the drive shaft from the differential housing.

NOTICE

- Do not pull on the drive shaft ; doing so will damage the boots. Be sure to use the pry bar.

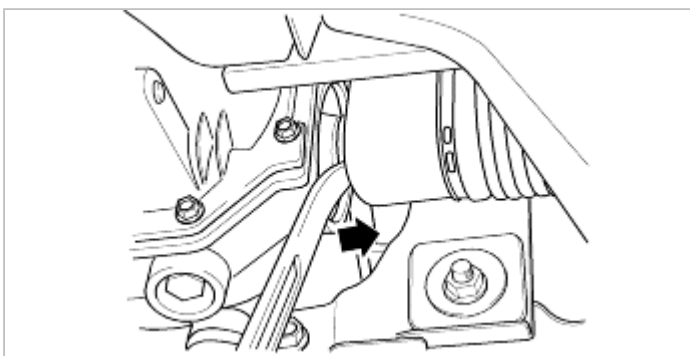

6. Remove the drive shaft from the knuckle

NOTICE

- Temporarily install the knuckle to the upper arm.

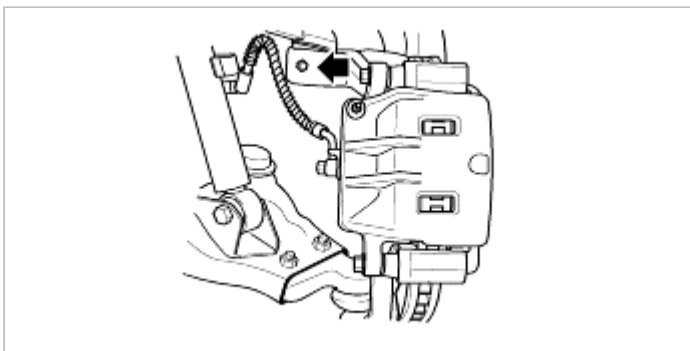
**INSTALLATION**

1. Coincide the joining mark between the drive shaft and the differential and insert the shaft.

CAUTION

- Insert the drive shaft (RH side) carefully into the oil seal to avoid any damage.

2. Install the knuckle assembly and tighten.
 - (1) Tie-rod ball joint

Tightening torque :
70-80 N·m (7.0-8.0 kg·m, 51-57 lb·ft)

(2) Upper arm link lock bolt

Tightening torque :
44-55 N·m (4.4-5.5 kg·m, 32-39 lb·ft)

3. Tighten the lock nut and then caulk the flange of lock nut on the end of drive shaft.

Tightening torque :
245-275 N·m (24.5-27.5 kg·m, 177-198 lb·ft)

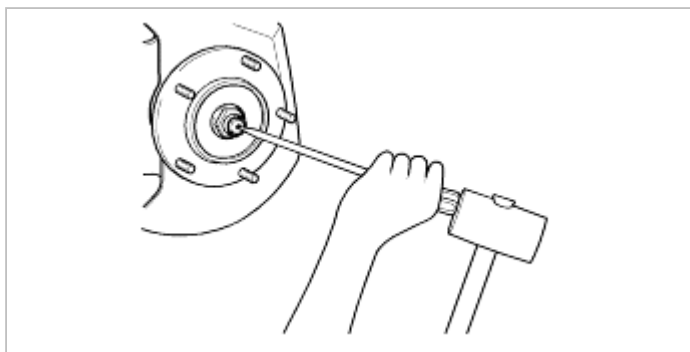

4. Install wheel and tire.

DISASSEMBLY

NOTICE

1. Do not disassemble the B.J assembly.
2. The Drive shaft joint uses special grease. Do not substitute with another type of grease.
3. The Boot band should be replaced with a new one.

1. Remove the T.S.J boot band and pull the boot from T.S.J outer race.

NOTICE

Be careful not to damage it.

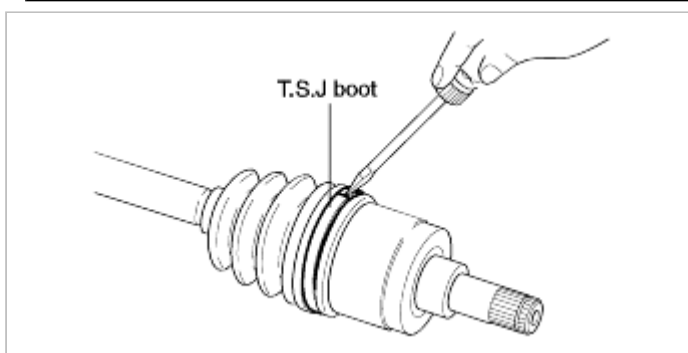

2. Remove the clip using a screwdriver.

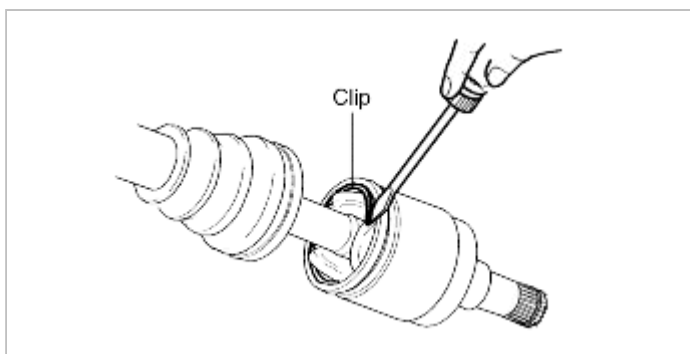

3. Remove the drive shaft from the T.S.J outer race.
4. Remove the snap ring and disassemble the inner race and ball from the shaft.
5. Remove the B.J boot band and pull out the T.S.J boot and the B.J boot.

CAUTION

If the boot is reused, wrap a tape around the drive shaft splines to protect the boot.

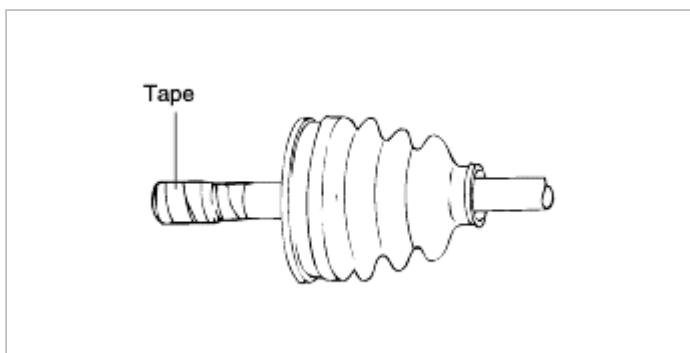
**REASSEMBLY**

1. Wrap a tape around the drive shaft spline (T.S.J side) to avoid boot damage.
2. Apply specified grease to the drive shaft and install the boots.

Items	Quantity (gr.)
B.J	170
T.S.J	140

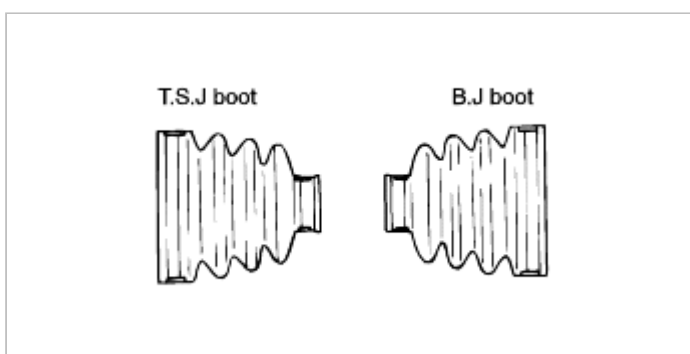

3. Add specified grease as much as was wiped away at the time of inspection.
4. Tighten the boot bands.

CAUTION

Keep the specified distance between the boot bands to control the air when they are tightened.

<https://autolibrary.ir>

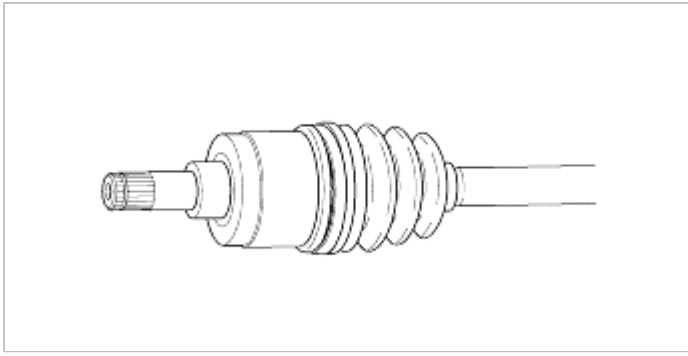

<https://autolibrary.ir>

2009 > G 3.3 DOHC >



REMOVAL (OUTPUT SHAFT)

1. Remove diff mounting bracket.

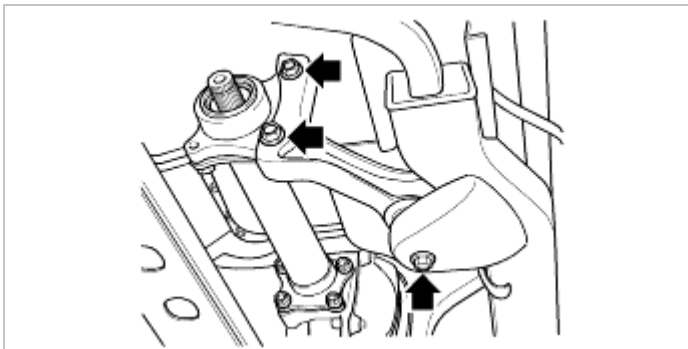

2. Remove output shaft from differential housing.

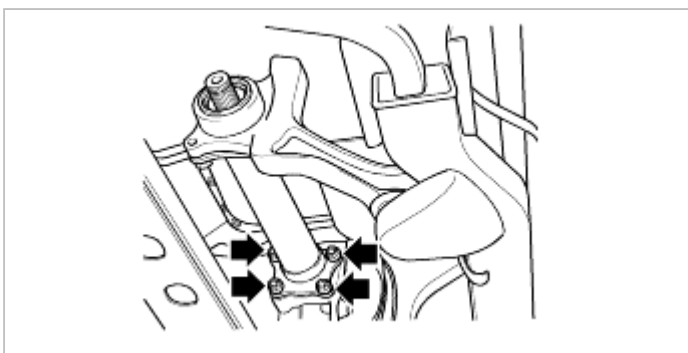

INSTALLATION

1. Install output shaft to differential case.

Tightening torque :

80-120 N·m (8-12 kg·m, 58-86 lb·ft)

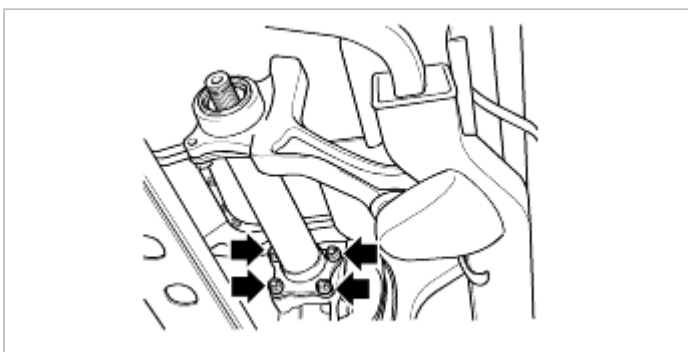
**CAUTION**

- Be carefully that oil seal does not damage by clip during install.

2. Install diff mounting bracket to the bearing housing.

Tightening torque :

110-150 N·m (11-15 kg·m, 80-108 lb·ft)

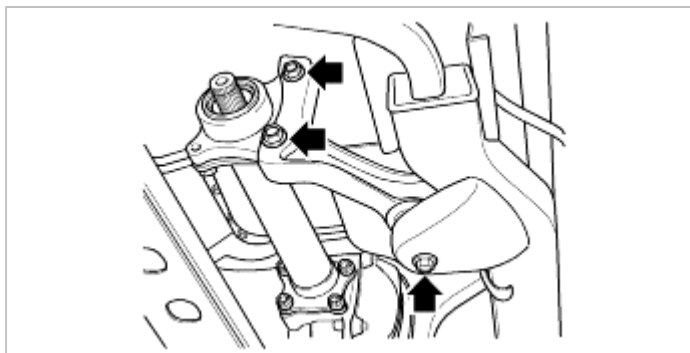

3. Tighten diff mounting bracket bolt.

DISASSEMBLY

1. Remove axle clip using plier.

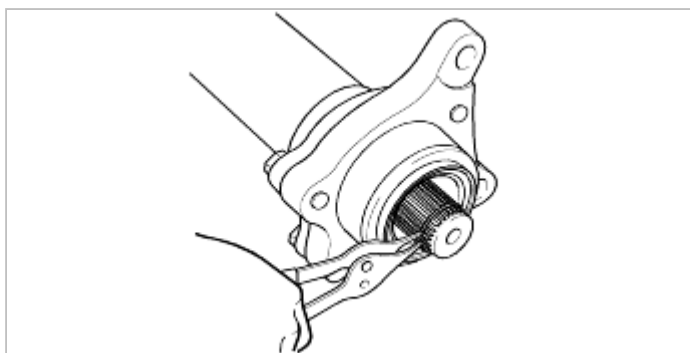

2. Remove output shaft housing.

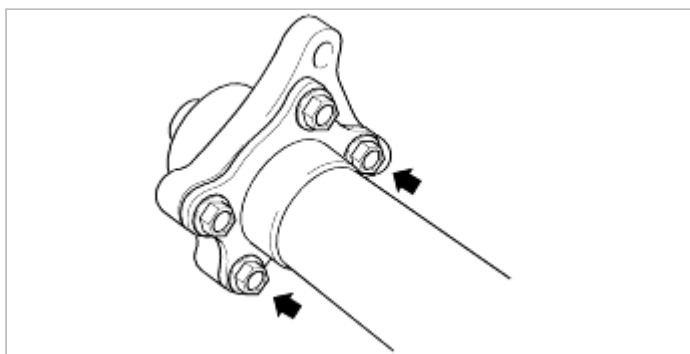

3. Using a hydraulic press, remove bearing housing from the output shaft.

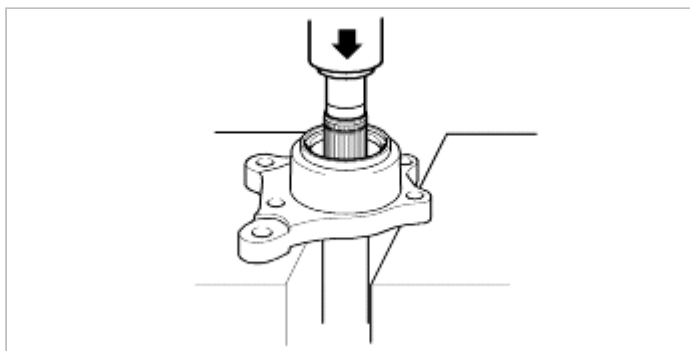

4. Remove dust seal and then using a hydraulic press, remove bearing.

INSPECTION

- Output shaft for damage.
- Bearing for roughness or noise.
- Dust seal for damage.

- Bearing housing for cracks.

REASSEMBLY (OUTPUT SHAFT)

1. Install dust seal into bearing housing.

NOTICE

- Apply the grease on the lip of dust seal.

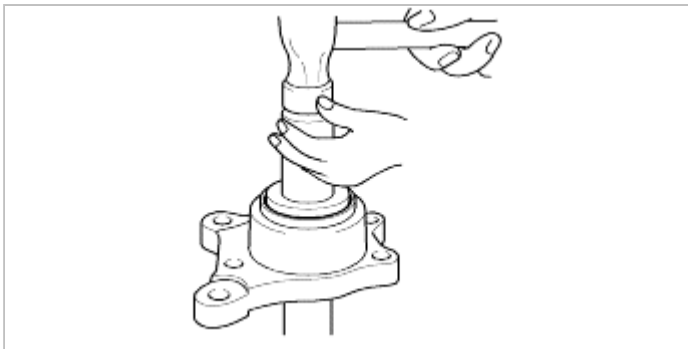

2. Using a hydraulic press, install bearing onto output shaft.
3. Using a hydraulic press, install shaft with bearing into bearing housing.

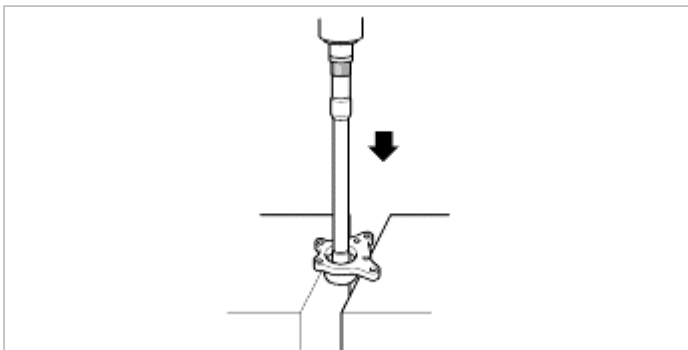

4. Install the output shaft housing to the bearing housing.

Tightening torque :

71-95 N·m (7.1-9.5 kg·m, 51-68 lb·ft)

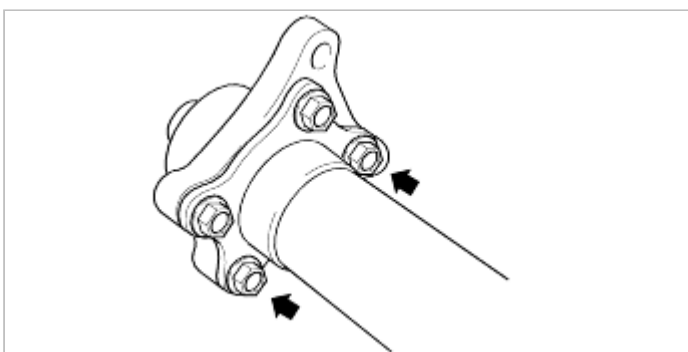

5. Using a plier, install new clip onto output shaft.

<https://autolibrary.ir>

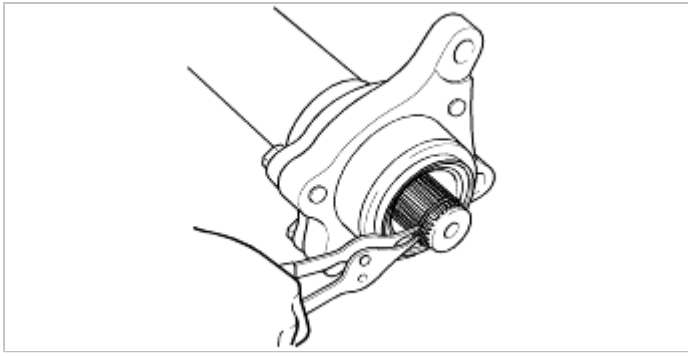

<https://autolibrary.ir>

2009 > G 3.3 DOHC >



INSPECTION

1. Remove two bolts and remove brake caliper from brake rotor. Temporarily tie caliper to vehicle frame with wire.
2. Mount dial indicator with plunger zeroed against brake rotor at 4.7 inch (12 cm) from rotor center.

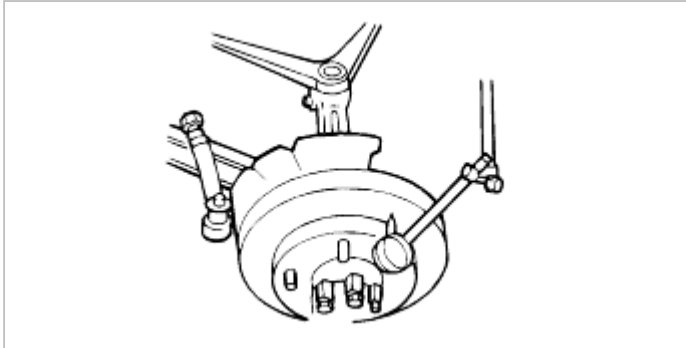

3. Turn rotor and read dial indicator for run out dimension.

Run out not to exceed 0.0012 in (0.03 mm)

2009 > G 3.3 DOHC >

**REMOVAL**

1. Remove the vehicle speed sensor.
2. Remove two bolts and remove brake caliper from brake rotor. Temporarily tie caliper to vehicle frame with wire.

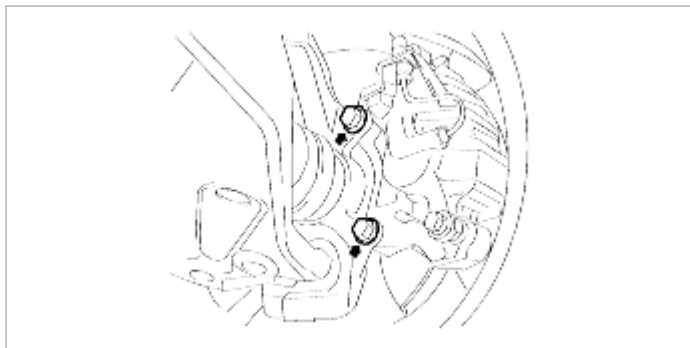

3. Remove two screws and remove brake rotor.
4. Using a lock nut wrench (or equivalent), remove lock nut and plain washer (2WD).

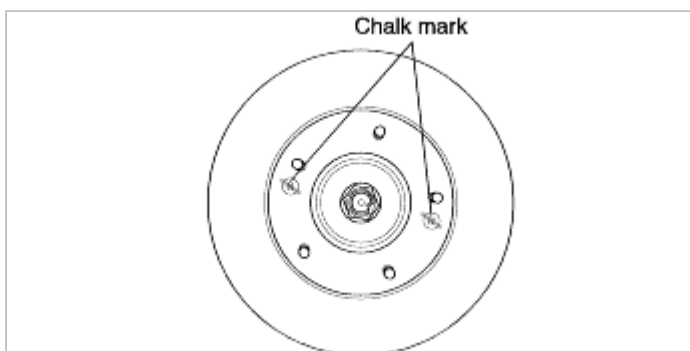

5. Remove the upper arm link lock bolt, spring washer and nut.

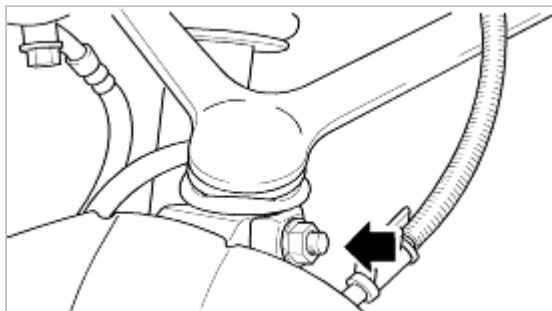

6. Remove tie rod end cotter pin and using a ball joint remover, remove tie rod end from steering knuckle.



7. Remove lower arm cotter pin using a ball joint remover, and remove lower arm from steering knuckle.

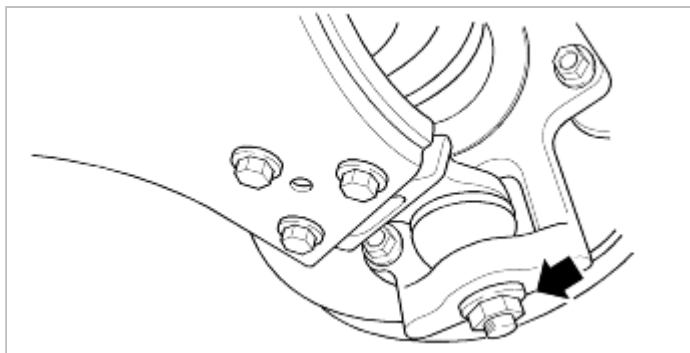

8. Remove steering knuckle from vehicle.

INSTALLATION

1. Put steering knuckle on the drive shaft end with upper and lower ball joints in mounting holes.
2. Attach lower arm, tighten lock nut, and install cotter pin.

Tightening torque :

160-180 N·m (16.0-18.0 kg·m, 116-130 lb·ft)

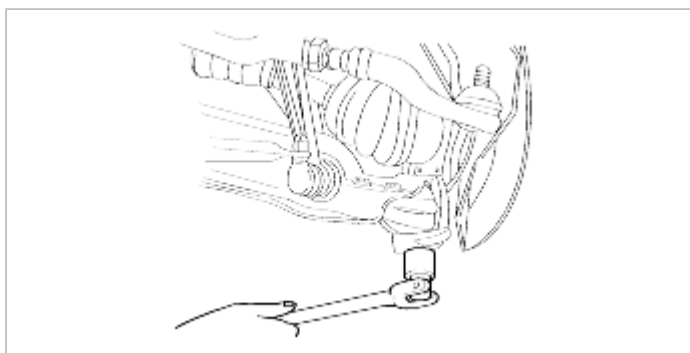

3. Attach tie rod end to knuckle, tighten nut, and install cotter pin.

Tightening torque :

70-80 N·m (7.0-8.0 kg·m, 51-57 lb·ft)

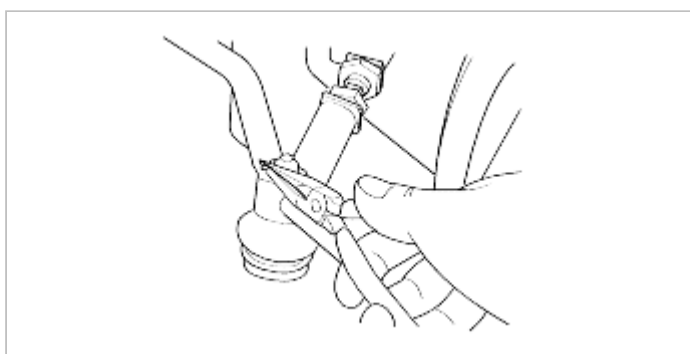

4. Insert upper arm link lock bolt with spring washer and tighten nut.

Tightening torque :

44-55 N·m (4.4-5.5 kg·m, 32-39 lb·ft)

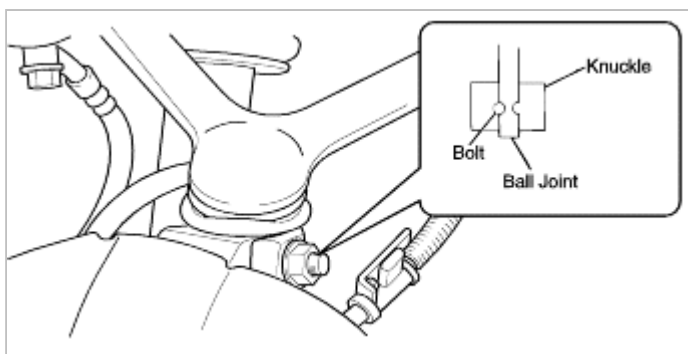

5. Install the chamfer of plain washer toward the bearing (2WD)

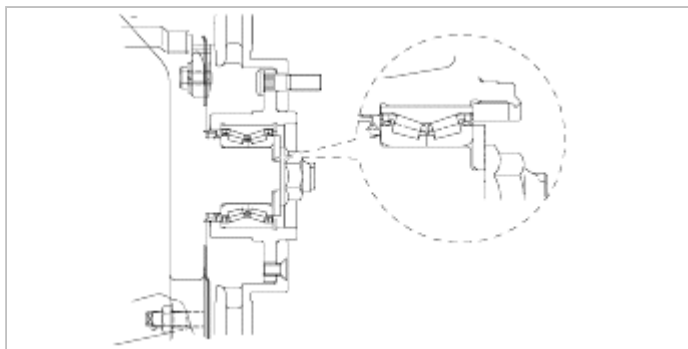

6. Screw lock nut up against wheel hub assembly and using a lock nut wrench, tighten nut to tightening torque to set bearing preload. Use spring scale to measure.

Bearing preload :

10 lb-in (Max 60 kg-cm)

Tightening torque :

245-275 N·m (24.5-27.5 kg·m, 178-198 lb-ft)

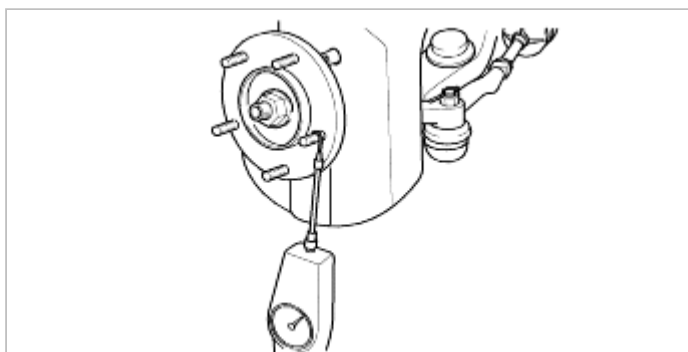

7. Caulk the flange of lock nut on the end of drive shaft.
8. Put brake rotor on wheel bearing hub bolts and install the two retaining screws.
9. Mount dial indicator with plunger zeroed against brake rotor at 4.7 in (12 cm) from rotor center.

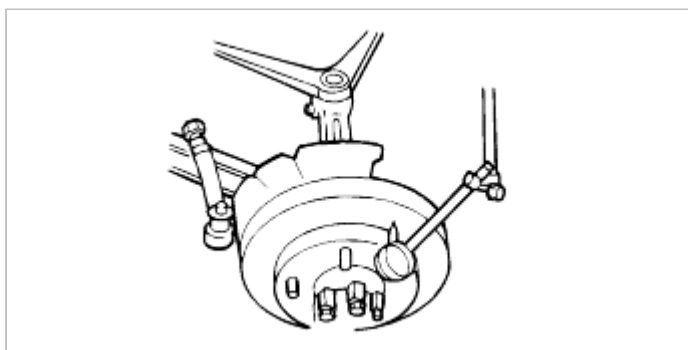

10. Turn rotor and read dial indicator for run out dimension.

Run out not to exceed 0.0012 inch (0.03 mm)

11. Install brake caliper and tighten two bolts.

Tightening torque :

80-104 N·m (8.0-10.4 kg·m, 57-75 lb·ft)



12. Install wheel and tire.

DISASSEMBLY

1. Using a screwdriver, pry out oil seal from knuckle (4WD).

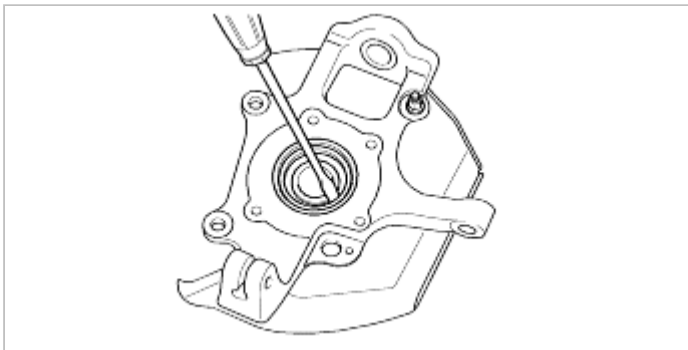

2. Press the wheel hub from the knuckle (4WD).
Press the knuckle and then remove wheel hub (2WD).

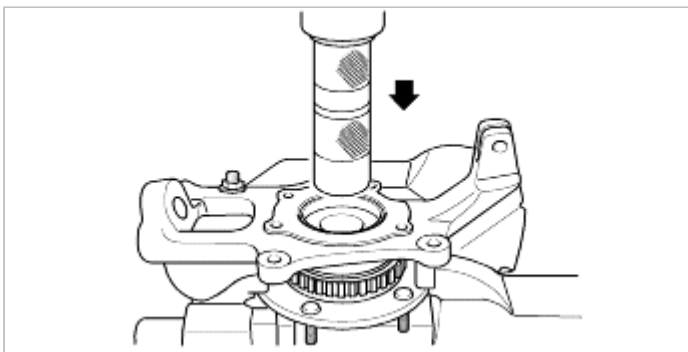

INSPECTION

1. Inspect bearing for wear or damage.
2. Inspect steering knuckle for wear or damage.

REASSEMBLY

1. Install the dust cover to the knuckle.
-

Tightening torque :

16-23 N·m (1.6-2.3 kg·m, 12-16 lb·ft)

2. Install new oil seal and then install the wheel hub to the knuckle by pressing.
3. Apply grease to the wheel bearing and seal lip.

2009 > G 3.3 DOHC >

**SERVICE INSPECTION PROCEDURE****AXLE SHAFT END PLAY CHECK**

1. Measure the axle shaft end play using a dial indicator.

Standard value : 0-0.05mm (0-0.002 in.)

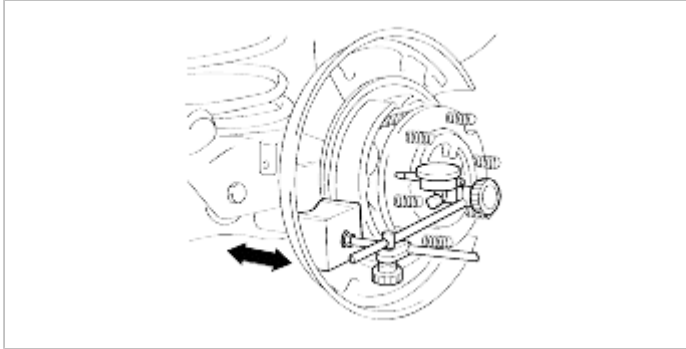

2. If the axle shaft end play exceeds the standard value, replace the bearing with a new one.

GEAR OIL LEVEL CHECK

1. Remove the filler plug and check the quantity of oil in the differential carrier.
2. It is enough if oil is applied until the filler plug.

Specified gear oil :

Hipoid gear oil

Conventional differential

SAE90, API GL-5

With Limited Slip Differential

SAE85W90, API GL-5

SPECIFIED GEAR OIL QUANTITY : 1.6 Liter

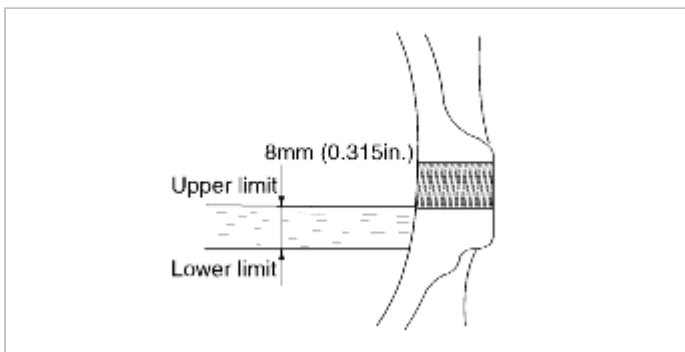

2009 > G 3.3 DOHC >



REMOVAL

1. Remove the disk brake and parking brake assembly (Refer to "BR Group").
2. Remove the parking brake cable and speed sensor cable.
3. Remove the rear axle shaft mounting bolt.

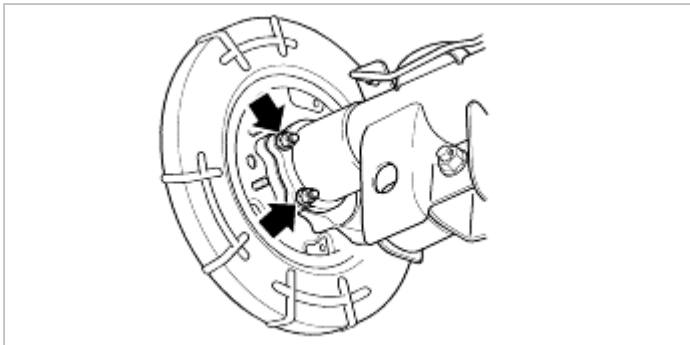

4. Remove the rear axle shaft.

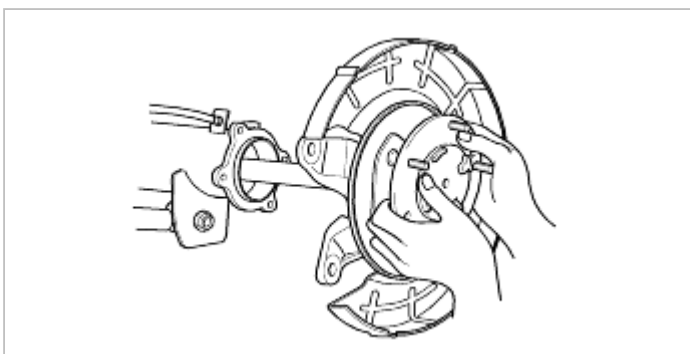

5. Using the special tool (09526-11100), remove the oil seal.

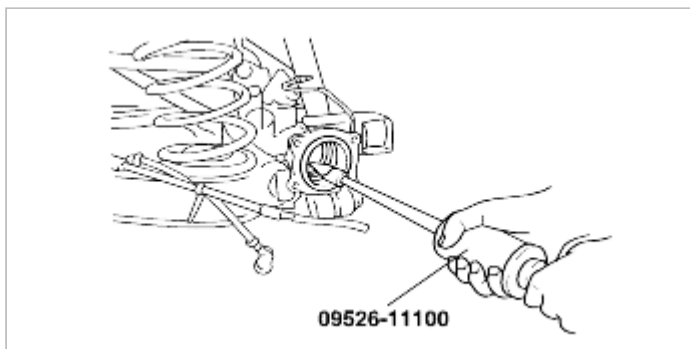

INSTALLATION

1. Installation is the reverse of removal.
2. Apply grease to the oil seal lip.
3. Using the special tools (09500-11000, 09532-11500), install the oil seal.

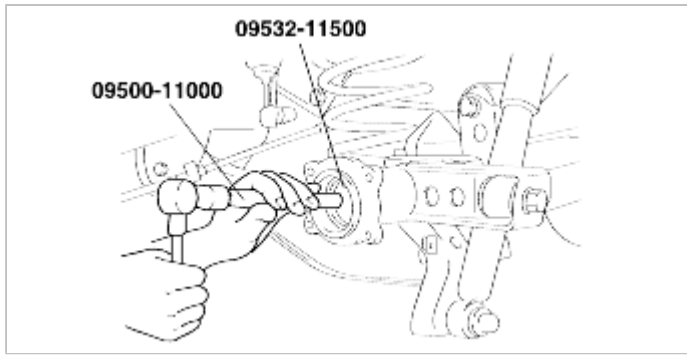

4. After installing the axle shaft, tighten the nut.

Tightening torque :

43-60 N·m (4.4-6.2 kg·m, 32-44 lb·ft)

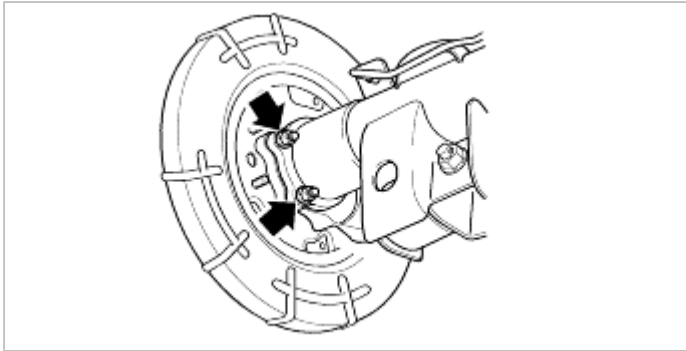

5. Adjust the parking brake lever stroke.

2009 > G 3.3 DOHC >



COMPONENTS

<2WD>

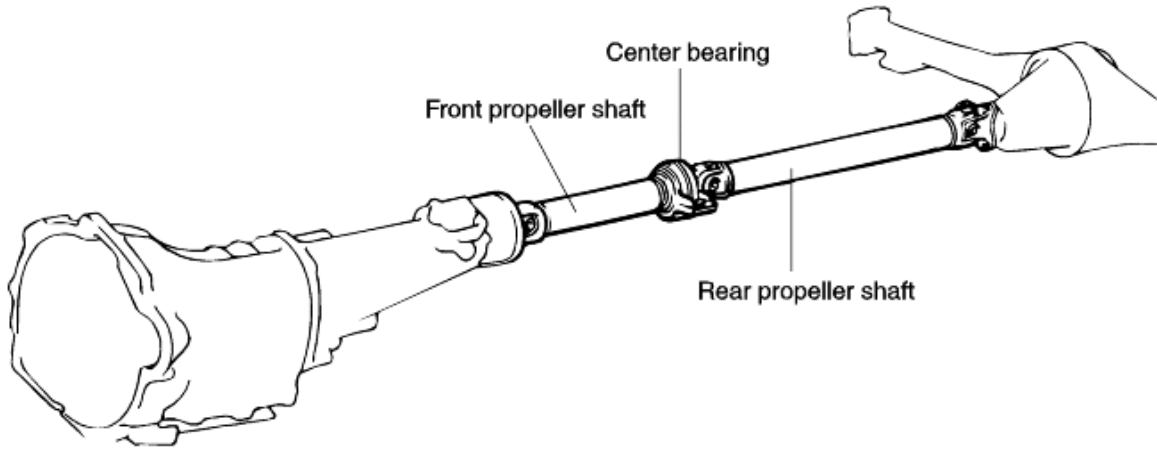

<4WD>

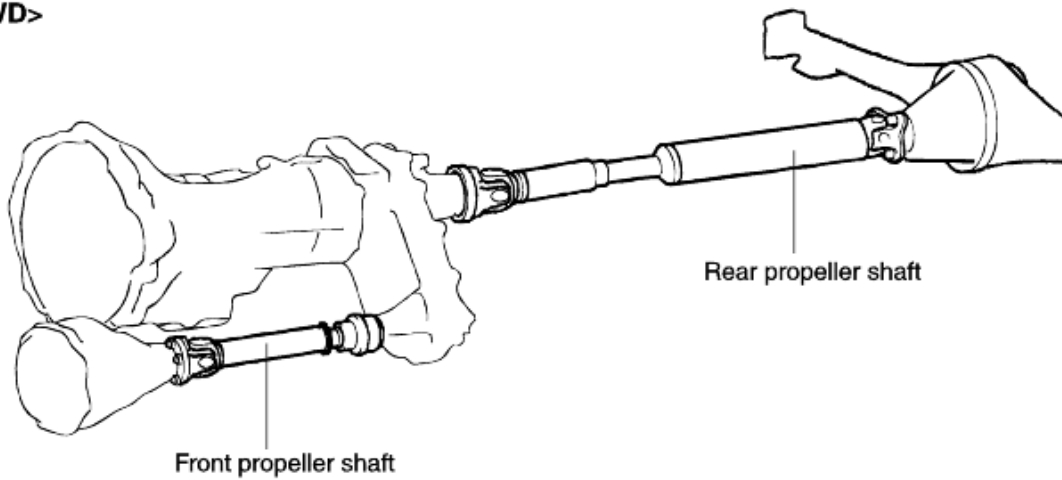

2009 > G 3.3 DOHC >

**INSPECTION**

1. Check the sleeve yoke, center yoke and flange yoke for wear, damage or cracks.
2. Check the propeller shaft yokes for wear, damage or cracks.
3. Check the propeller shaft for bends, twisting or damage.
4. Check the universal joints for smooth operation in all directions.

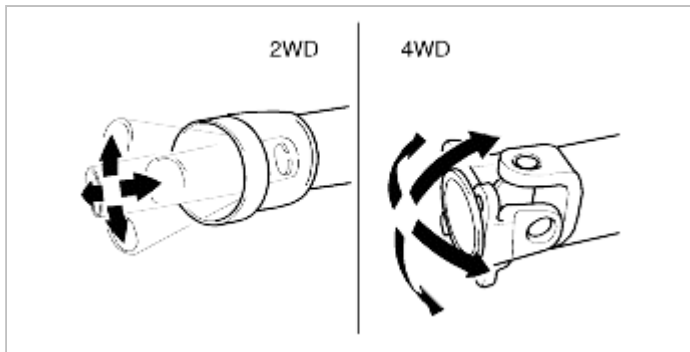

5. Check the center bearing for smooth movement (2WD).
6. Check the center bearing mounting rubber for damage or deterioration (4WD).
7. Measure the propeller shaft run out with a dial indicator.

Limit	Front	0.3 mm (0.012 in.) or less
	Rear	0.3 mm (0.012 in.) or less

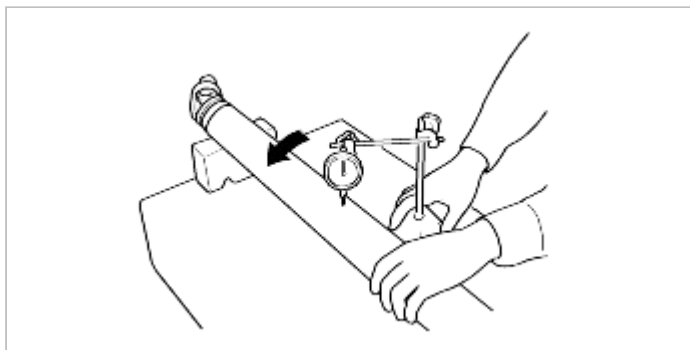
**REMOVAL**

1. Raise and support vehicle.
2. Place index marks (reference marks) on the propeller shaft and their matching transfer case and differential input shafts.

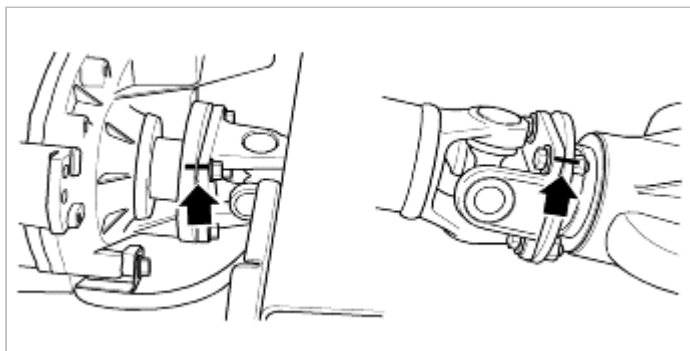

3. Remove four bolts holding universal flange to transfer case (4WD).

Remove bolts holding center bearing bracket (2WD).

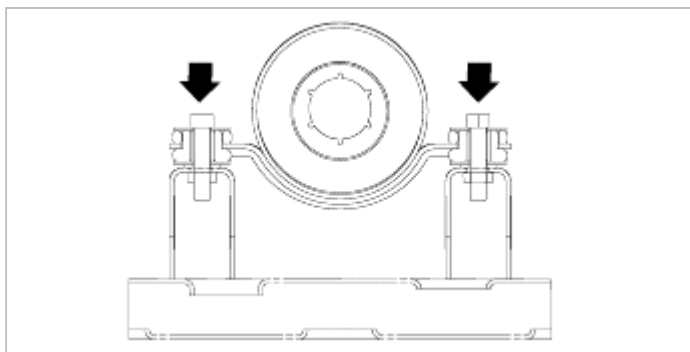

4. Remove four bolts holding universal flange to differential.
5. Remove propeller shaft.

NOTICE

- When removing the propeller shaft, be careful not to damage the dust cover or spline.

INSTALLATION

1. Connect propeller shaft flange to companion flange on front differential (4WD).
 - A. Align index marks on the flange and connect the flanges with four bolts and nuts.
 - B. Tighten the bolts and nuts.

Tightening torque :

26-30 N·m (2.6-3.0 kg·m, 19-21 lb·ft)

- Full time 4WD

50-60 N·m (5.0-6.0 kg·m, 36-43 lb·ft)

- Part time 4WD

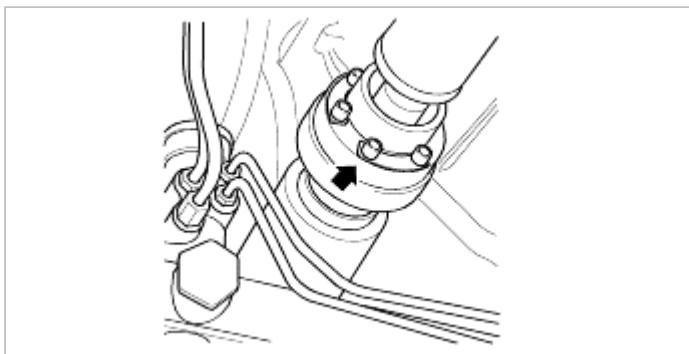

2. Connect front propeller shaft flange to companion flange on transfer (4WD).
 - A. Align index marks on the flange and connect the flanges with four bolts and nuts.
 - B. Tighten the bolts.

Tightening torque :

50-60 N·m (5.0-6.0 kg·m, 36-43 lb·ft)

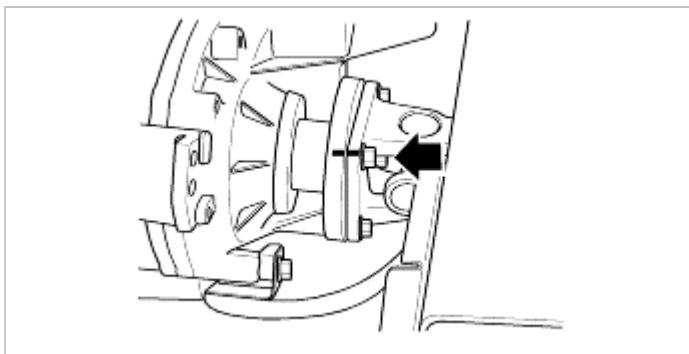

3. Connect rear propeller shaft flange to companion flange on transfer. (4WD)
 - A. Align index marks on the flange and connect the flanges with four bolts and nuts.
 - B. Tighten the bolts.

Tightening torque :
50-60 N·m (5.0-6.0 kg·m, 36-43 lb-ft)

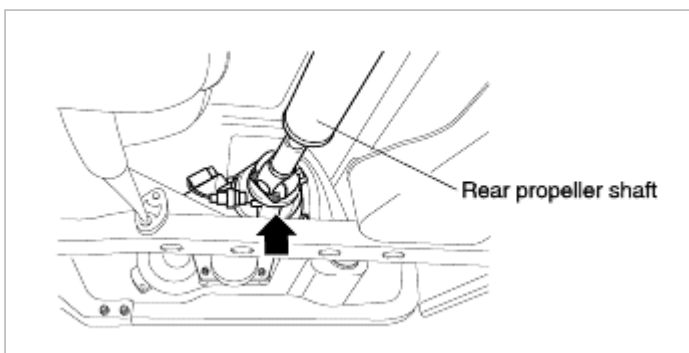

4. Connect the propeller shaft spline to transmission (2WD)
 - A. Align index mark on the spline and then install the propeller shaft.
 - B. Tighten the bolts holding the center bearing bracket.

Tightening torque :
37-54 N·m (3.7-5.4 kg·m, 27-39 lb-ft)

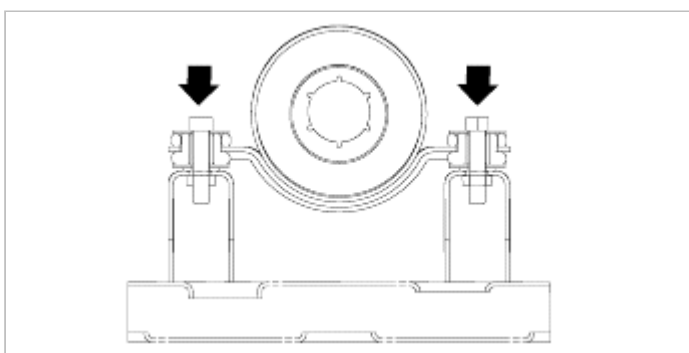

CAUTION

- Be careful not to damage the dust cover of propeller shaft when installing the propeller shaft (2WD)

5. Connect propeller shaft flange to companion flange on rear differential.
 - A. Align index marks on the flange and connect the flange with four bolts and nuts.
 - B. Tighten the bolts and nuts.

Tightening torque :

50-60 N·m (5.0-6.0 kg·m, 36-43 lb·ft)

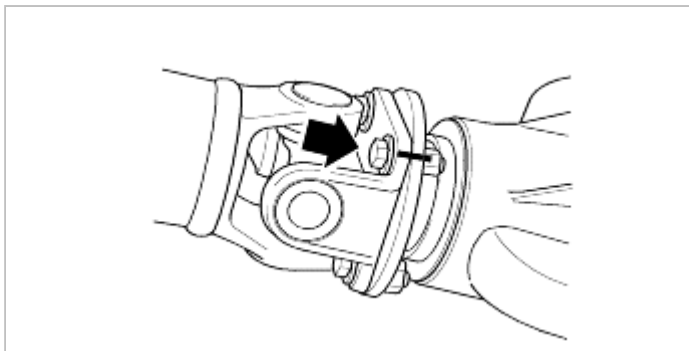

6. After installing the propeller shaft fill the grease into the nipple until it comes out from the sleeve yoke plug hole.



Components

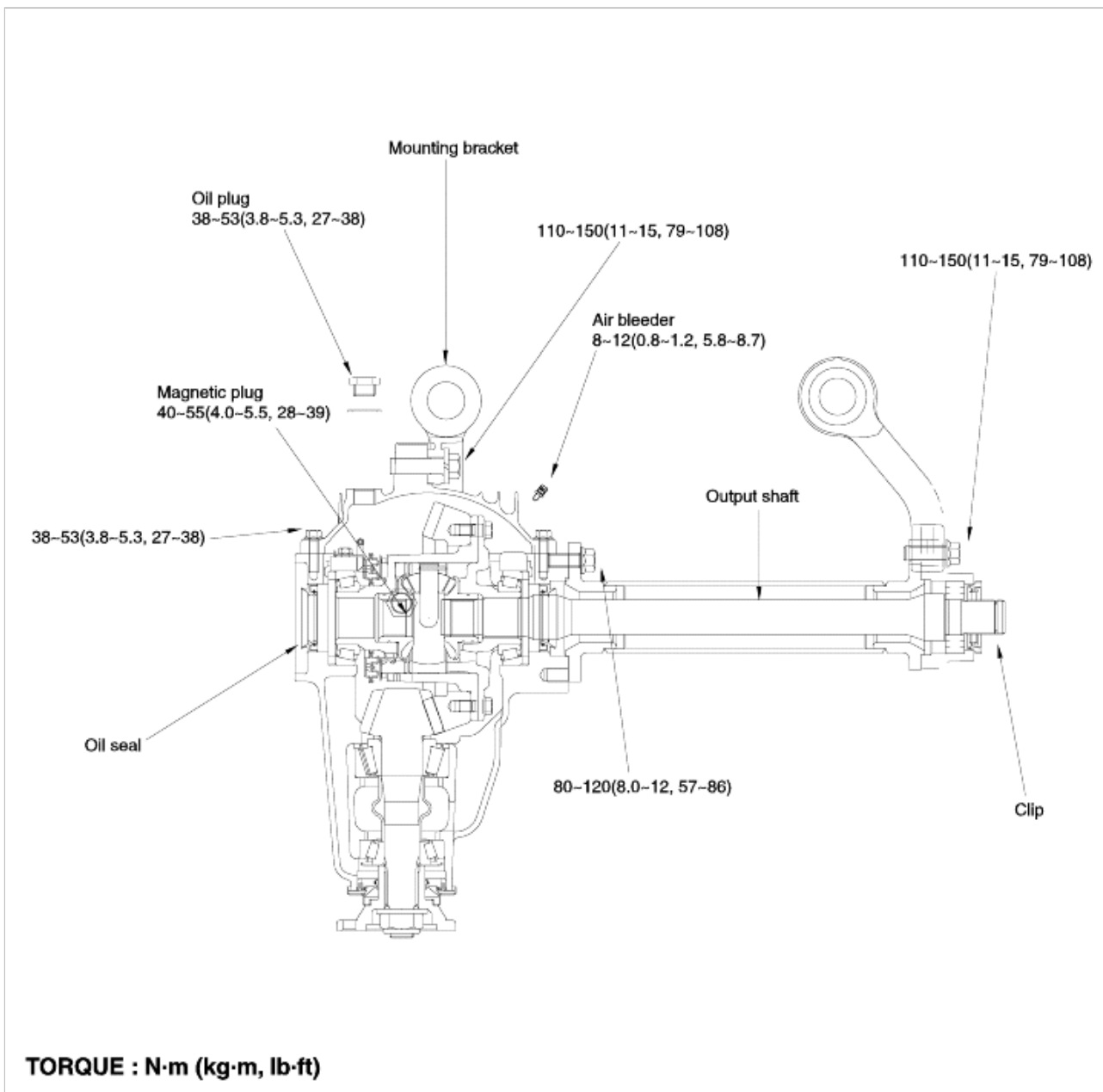

Front differential components

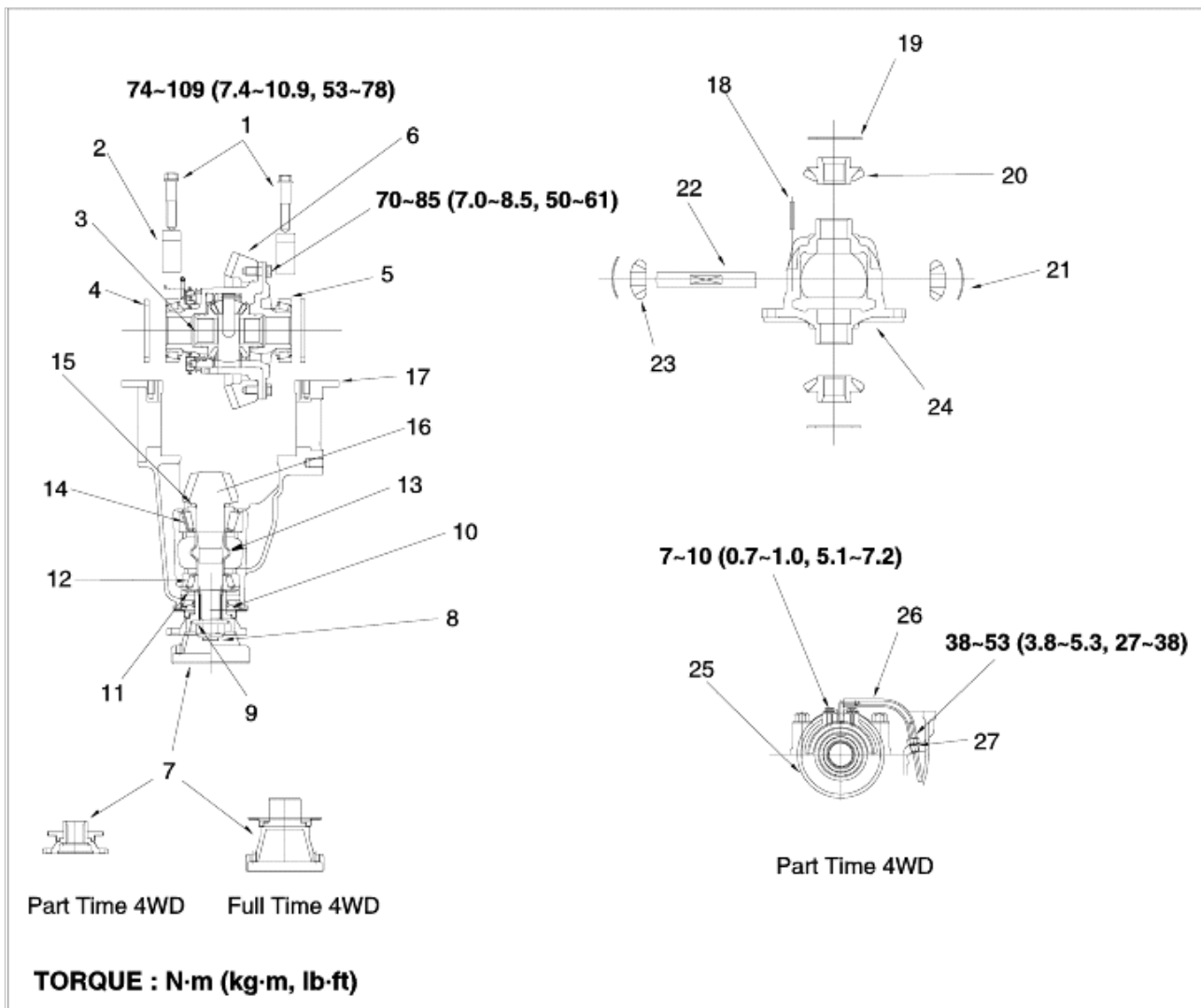

- 1. Bearing cap bolt.
- 2. Bearing cap
- 3. Differential assembly
- 4. Spacer
- 5. Side bearing
- 6. Ring gear
- 7. Companion flange
- 8. Lock nut
- 9. Lock washer

- 10. Oil seal
- 11. Oil slinger
- 12. Outer bearing
- 13. Distance piece
- 14. Inner bearing
- 15. Spacer
- 16. Drive pinion
- 17. Carrier assembly
- 18. Pin

- 19. Thrust washer
- 20. Side gear
- 21. Washer
- 22. Pinion shaft
- 23. Pinion gear
- 24. Case
- 25. Actuator
- 26. Hose
- 27. Packing

2009 > G 3.3 DOHC >



Removal

1. Drain oil.

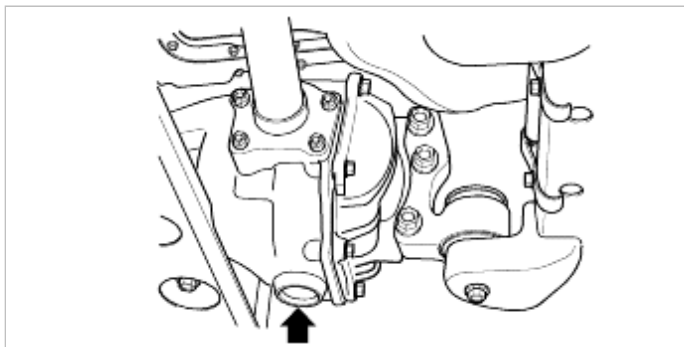

2. Remove the drive shaft and the output shaft.

CAUTION

When removing the drive shaft, be careful not to damage the differential carrier oil seal by interference of spline part.

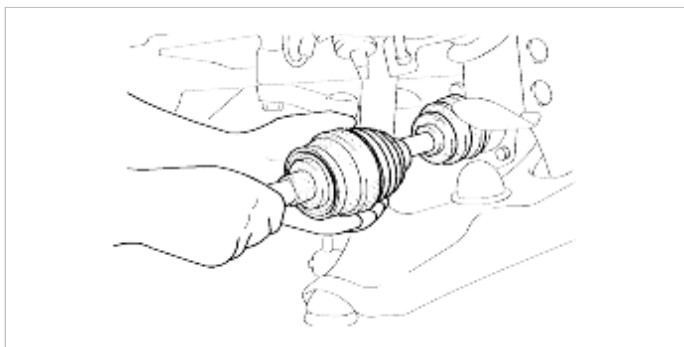

3. Remove the front propeller shaft.

NOTICE

Make match mark on the flange yoke and differential companion flange to avoid any mistake when installing them again.

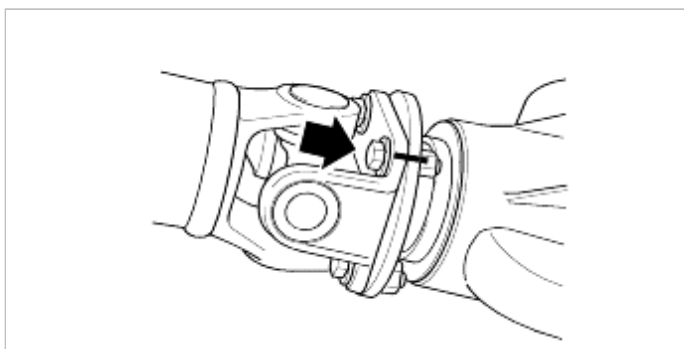

4. Remove the power steering tube mounting bracket.

Tightening torque :

18-23 N·m (1.8-2.3 kg·m, 13-16 lb·ft)

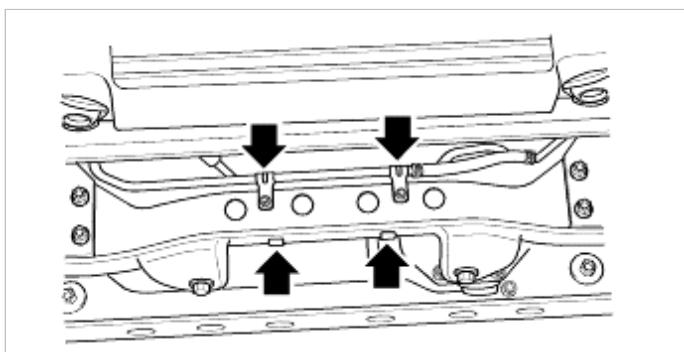

5. Remove the differential mounting bracket.

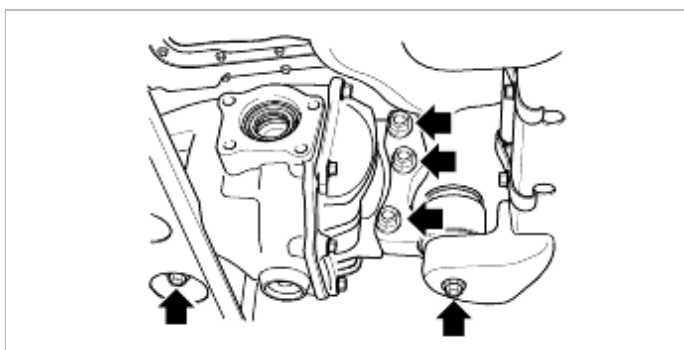

6. Remove the front member.

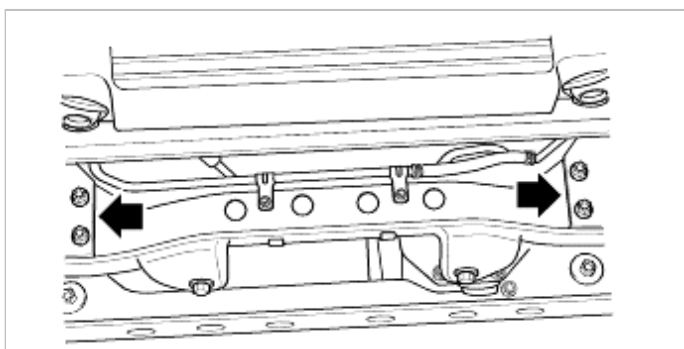

7. Remove the differential mounting bolt.

8. Remove the differential carrier.

Installation

1. Installation is the reverse of removal.

2. Align the matchmark on the flange yoke and the companion flange.
Tighten the propeller shaft and the front differential carrier.

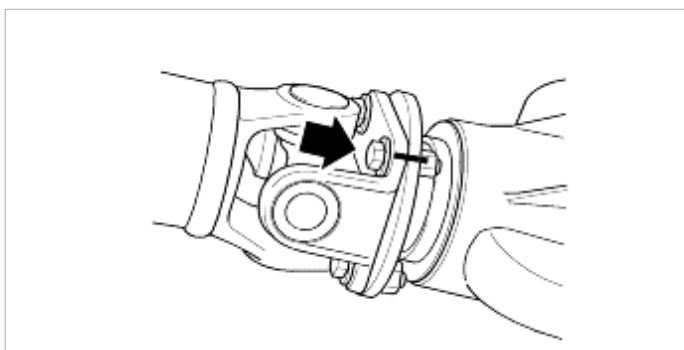

INSPECTION BEFORE DISASSEMBLY

Mount the differential carrier on the special tool(09517-43401).

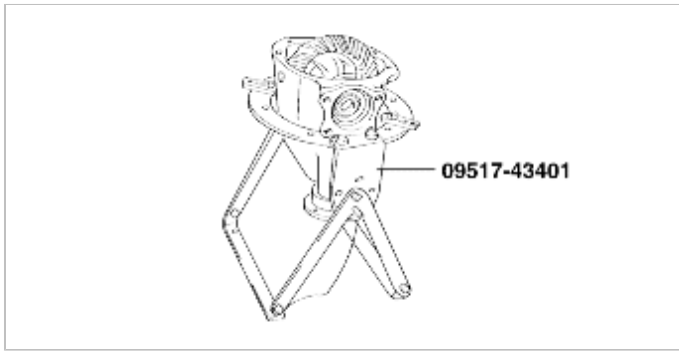

FINAL DRIVE GEAR BACKLASH

1. Fix the drive gear so it cannot move and measure the final drive gear backlash with a dial indicator.

NOTICE

Measure at four points or more on the circumference of the drive gear.

Standard value : 0.09-0.11mm (0.0035-0.0043 in.)

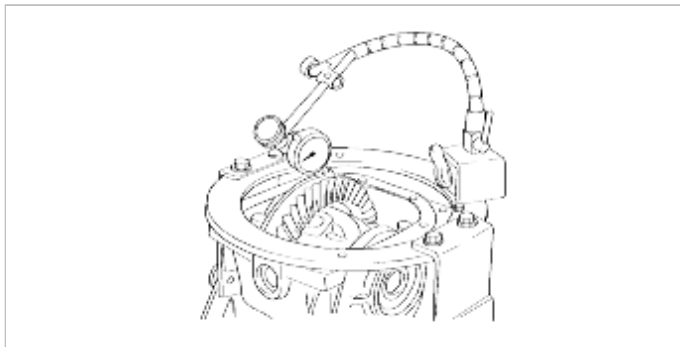

DRIVE GEAR RUNOUT

Check the back-face lash as follows:

1. Place a dial gauge on the back-face of the drive gear and measure the runout.

Limit : 0.05 mm (0.0020 in.)

2. If the runout is beyond the limit, check that there are no foreign substances between the drive gear and differential case and, that the bolts fixing the drive gear are not loose.
3. If nothing is wrong in check (2), adjust the drive gear depth and remeasure.

NOTICE

If these adjustments are impossible, replace the case or install a new drive gear/drive pinion as a set.

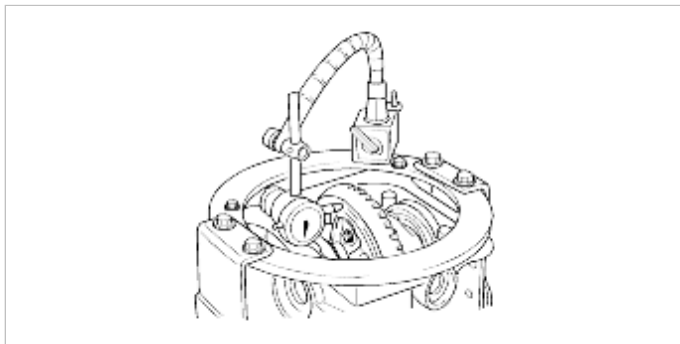

DIFFERENTIAL GEAR BACKLASH

1. Fix the side gear with a wedge so it cannot move and measure the differential gear backlash with a dial indicator on the pinion gear.

NOTICE

Take the measurements at two places (4 places for LSD) on the pinion gear.

Standard value : 0-0.1 mm (0-0.0039 in.)

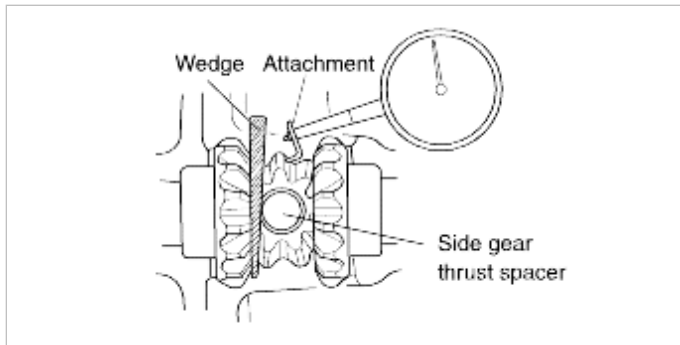

2. If the backlash exceeds the limit, adjust using side bearing spacers.

NOTICE

If adjustment is impossible, replace the side gear and pinion gears as a set.

FINAL DRIVE GEAR TOOTH CONTACT

Check the final drive gear tooth contact by following the steps below :

1. Apply the same amount of machine blue slightly to both surfaces of the drive gear teeth.

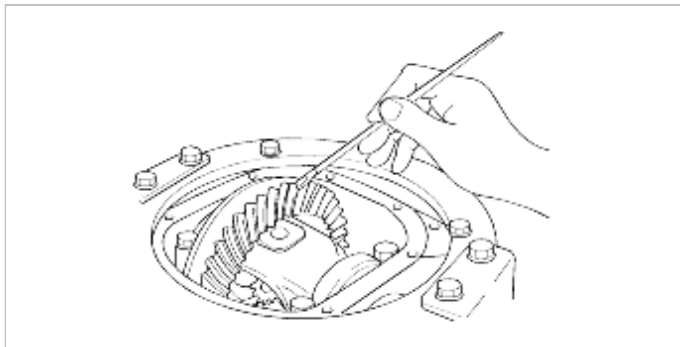

2. Insert a brass rod between the differential carrier and the differential case, and then rotate the companion flange by hand (once in the normal direction, and then once in the reverse direction) while applying a load to the drive gear so that some torque (approximately 25-30 kg-cm) is applied to the drive pinion.

CAUTION

If the drive gear is rotated too much, the tooth contact pattern will become unclear and difficult to check.

3. Check the tooth contact pattern.

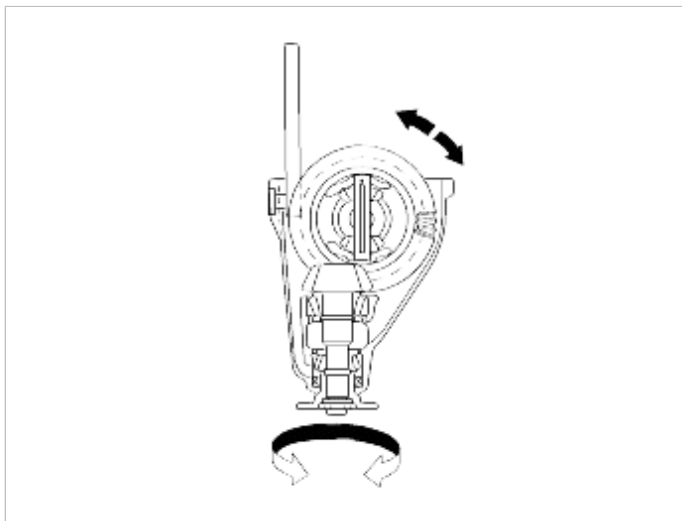

Standard tooth contact pattern

1. Narrow tooth side
2. >Drive-side tooth surface (the side receiving power during acceleration)
3. Wide tooth side
4. Coast-side tooth surface (the side receiving power during coast-down)

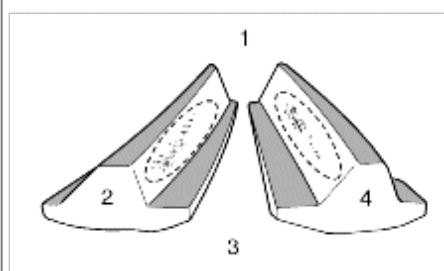

Problem

Solution

Tooth contact pattern resulting from excessive pinion height

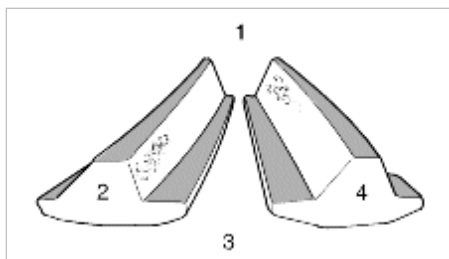

The drive pinion is positioned too far from the center of the drive gear.

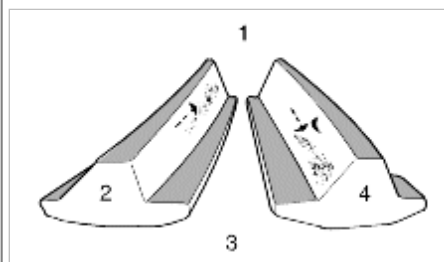

Increase the thickness of the pinion height adjusting shim, and position the drive pinion closer to the center of the drive gear.
Also, for backlash adjustment, reposition the drive gear further from the drive pinion.

Tooth contact pattern resulting from insufficient pinion height

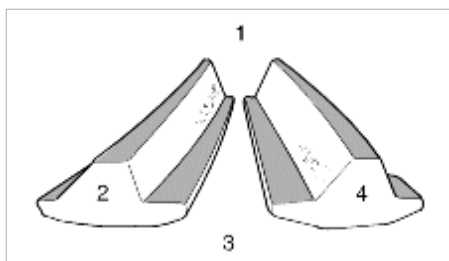

The drive pinion is positioned too close to the center of the drive gear.

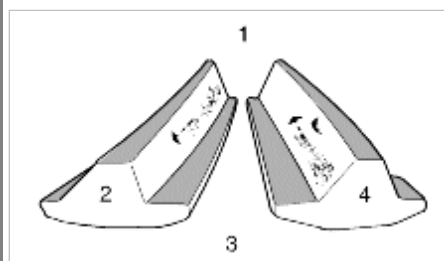

Decrease the thickness of the pinion height adjusting shim, and position the drive pinion further from the center of the drive gear.
Also, for backlash adjustment, reposition the drive gear closer to the drive pinion.

- A. Tooth contact pattern is a method for judging the result of the adjustment of drive pinion height and final drive gear backlash. The adjustment of drive pinion height and final drive gear backlash should be repeated until the tooth contact patterns are similar to the standard tooth contact pattern.
- B. When you cannot obtain a correct pattern, the drive gear and drive pinion have exceeded their limits. Both gears should be replaced as a set.

4WD CONTROL SYSTEM (PART TIME 4WD)

FUNCTION CHECK

1. Air pressure gauge is attached in between air hoses that connect differential (actuator) with air pump motor assy. Air pressure gauge adjustment screw shall be fastened until it stops ultimately. And make a blind stopper at air check side by using fuel hose etc.

CAUTION

- Air pressure gauge shall be installed by using 3-way union etc.
- Take heed not to snap or bend the piping hose.

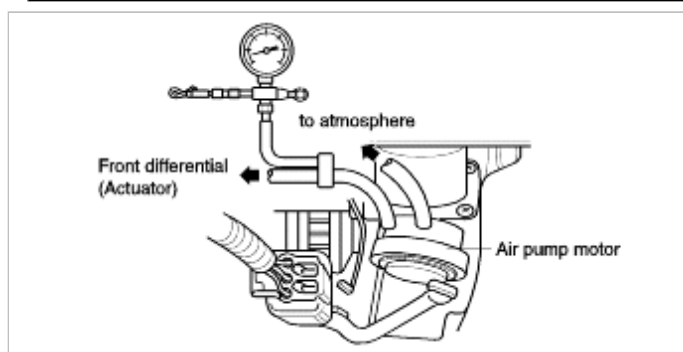

2. Turn the ignition switch on and shift the transfer lever 2H→4H.
3. Check that the motor starts to revolve in 1 second and stops when Air pressure gauge value displayed with in the specified value.

Specified pressure :

37-57 kPa (5.4-8.2 lb/in², 0.38-0.58 kgf/cm²)

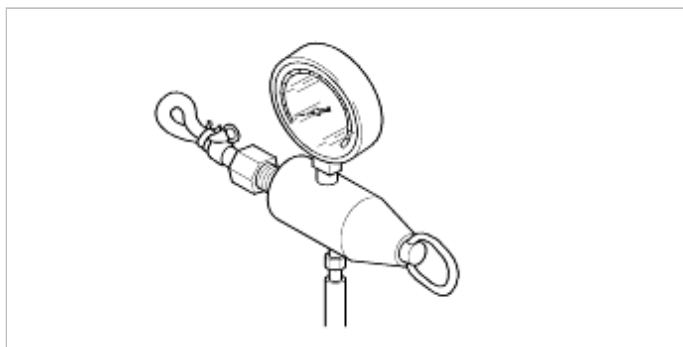

4. Check that if transfer lever is shifted to 2H then promptly Air pressure gauge value drops down.
5. Confirm that motor returns when Air pressure adjustment screw has been loosened to lower the gauge pressure value after motor had started to revolve by shifting transfer lever to 4H. And also check that the motor stops after several seconds since it started to run.

ACTUATOR CHECK

1. Detach air hose from air pump motor assy. and then attach Air pressure gauge at air hose.
2. Attach compressor air hose to Air pressure gauge and then set to specified pressure by fastening adjustment screw. Whence check that actuator is operated to affect the axle lock.

Specified pressure :
37 kPa (5.4 lb/in², 0.38 kgf/cm²).

WARNING

Take heed that there is potential for diaphragm breakage if pressure beyond 200 kPa (28 lb/in², 2.0 kgf/cm²) is applied.
Do not use the air gun.

INSPECTION

1. Check the companion flange for wear or damage.
2. Check the bearings for wear or discoloration.
3. Check the gear carrier for cracks.
4. Check the drive pinion and drive gear for wear or cracks.
5. Check the side gears, pinion gears and pinion shaft for wear or damage.
6. Check the side gear spline for wear or damage.
7. Check the length of the distance piece.

Standard length :
54.80-58.09 mm(2.16-2.21 in.)

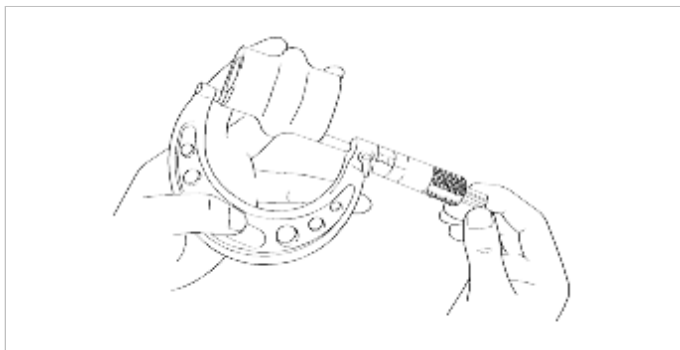

8. Check the air pump motor
 - (1) Attach air pressure gauge, voltmeter and battery to air pump motor as in figure. Air pressure gauge adjustment screw shall be fastened until it stops ultimately. And make a blind stopper at air check side by using fuel hose etc.

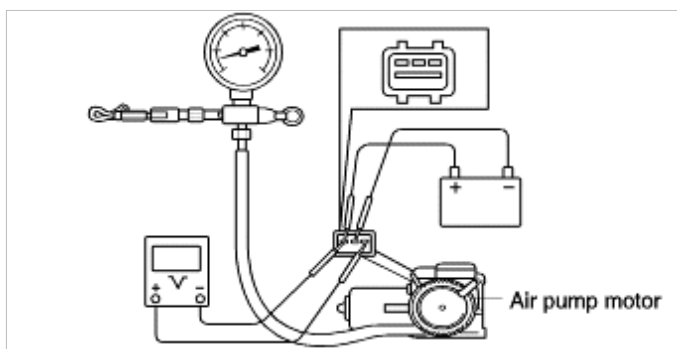

- (2) Confirm that motor runs when battery has been connected. And check that motor stops when returned to specified pressure.

Specified pressure :
37-57 kPa (5.4-8.2 lb/in², 0.38-0.58kgf/cm²)

CAUTION

Check also air leak.

- (3) Read voltmeter indication value so as to check if it is within specified range.

Voltage :
about 0 V (when motor runs)
10-14 V (when motor stopped)

9. Check the actuator.

- (1) Attach air pressure gauge to actuator as in figure.

CAUTION

Loosen adjustment screw before attaching air hose to air pressure gauge.

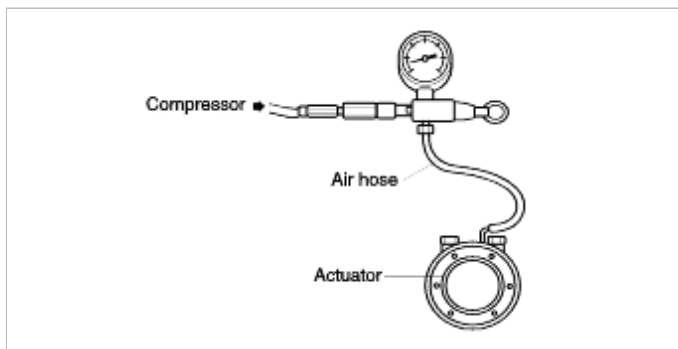

- (2) Check that actuator is operated when air pressure gauge adjustment screw has been tightened to set at specified pressure. Also check air leak from actuator.

Adjusted pressure :
37 kPa (5.4 lb/in², 0.38 kgf/cm²)

CAUTION

Take heed that there is potential for diaphragm breakage if pressure beyond 200 kPa (28 lb/in², 2.0 kgf/cm²) is applied.
Do not use the air gun.

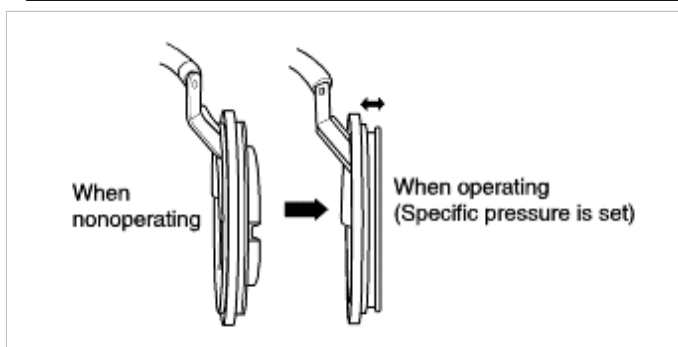
**DISASSEMBLY**

1. REMOVAL OF THE DIFFERENTIAL CASE ASSEMBLY

CAUTION

Remove the differential case assembly slowly and carefully. Be careful so that the side bearing outer race

is not dropped.

NOTICE

Keep the right and left side bearings separate so that they are not mixed during reassembly.

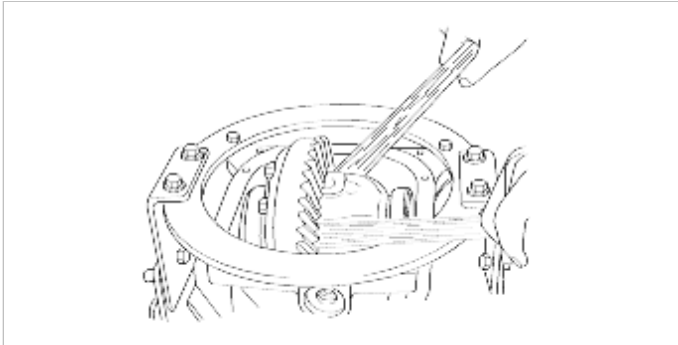

2. REMOVAL OF THE SIDE BEARING INNER RACES

Fit the nut on top of the differential case, and then use the special tool(09517-43001) to remove the side bearing inner race.

NOTICE

Attach the prongs of the special tool to the inner race of the side bearing through the notched section in the differential case.

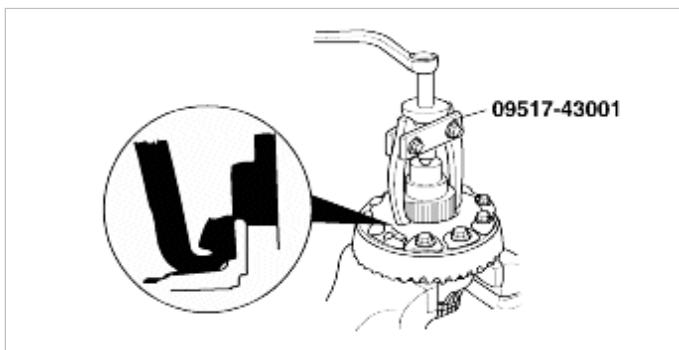

3. REMOVAL OF DRIVE GEAR

- A. Make the matchmarks to the differential case and the drive gear.
- B. Loosen the drive gear attaching bolts in diagonal sequence to remove the drive gear.

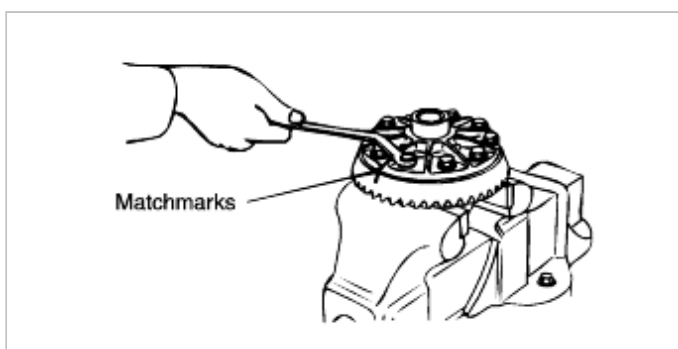

4. REMOVAL OF LOCK PIN (FOR CONVENTIONAL DIFFERENTIAL)

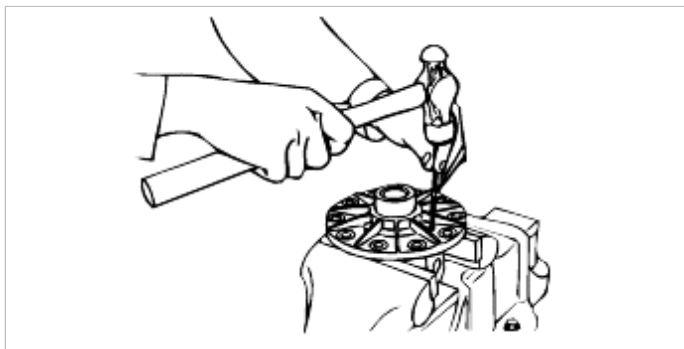

5. REMOVAL OF SELF-LOCKING NUT

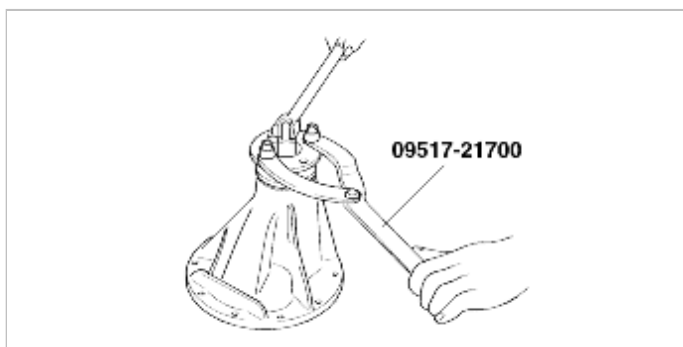

6. REMOVAL OF DRIVE PINION

- A. Make the matchmarks to the drive pinion and companion flange.

CAUTION

Matchmarks should not be made to the contact surfaces of the companion flange and the propeller shaft.

- B. Drive out the drive pinion together with the drive pinion spacer and drive pinion front shims.

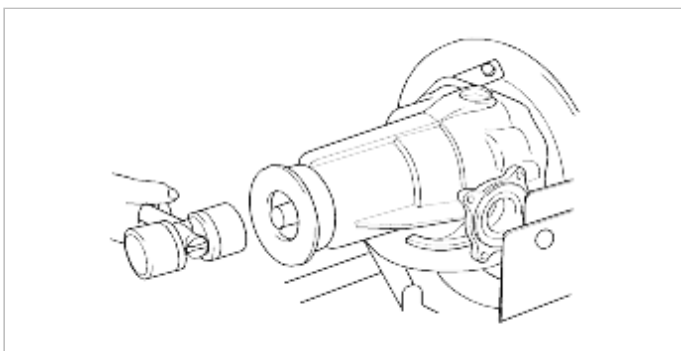

7. REMOVAL OF DRIVE PINION INNER BEARING INNER RACE

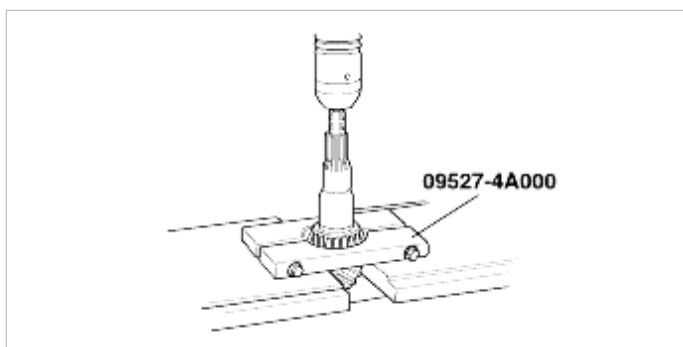

8. REMOVAL OF OIL SEAL / DRIVE PINION OUTER BEARING INNER RACE / DRIVE PINION OUTER BEARING OUTER RACE

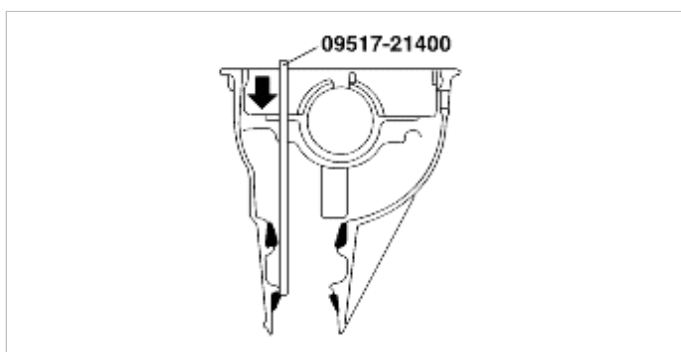

9. REMOVAL OF DRIVE PINION INNER BEARING OUTER RACE

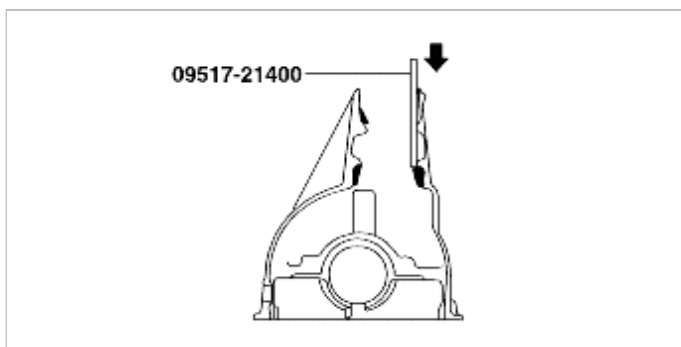

REASSEMBLY

1. PRESS-FITTING OIL SEAL

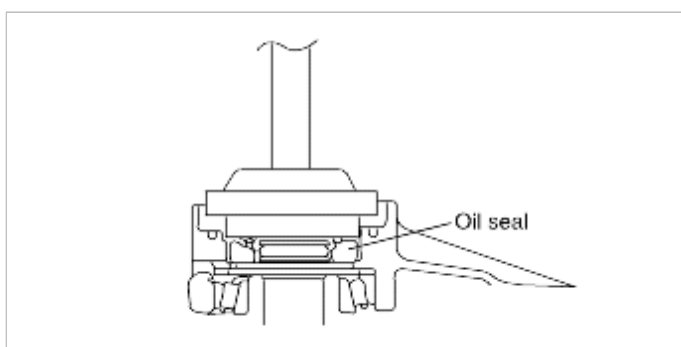

2. DRIVE PINION OUTER BEARING OUTER RACE INSTALLATION

CAUTION

When press-fitting the outer race, do not incline it.

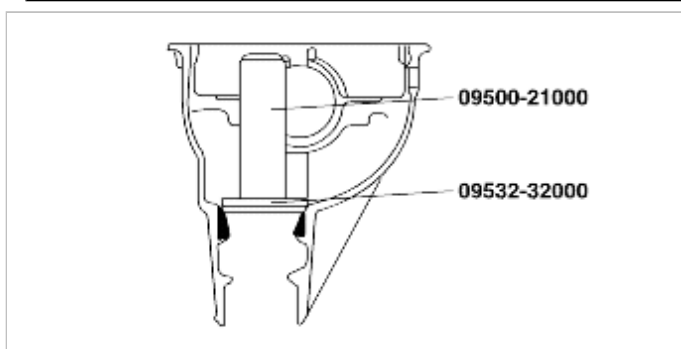

3. DRIVE PINION INNER BEARING OUTER RACE INSTALLATION

CAUTION

When press-fitting the outer race, do not incline it.

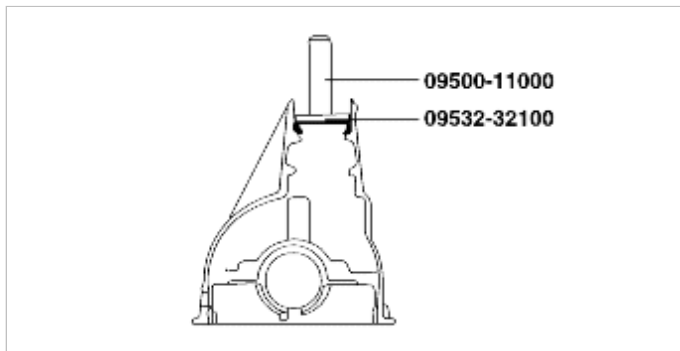

4. ADJUSTMENT OF PINION HEIGHT

Adjustment the drive pinion height by the following procedure.

- (1) For assembly of pinion, use drive pinion model(0K993 270 A01), pinion height adjustment gauge body (0K993 270 A09) and gauge block(ht. 28 mm(1.102 in)).

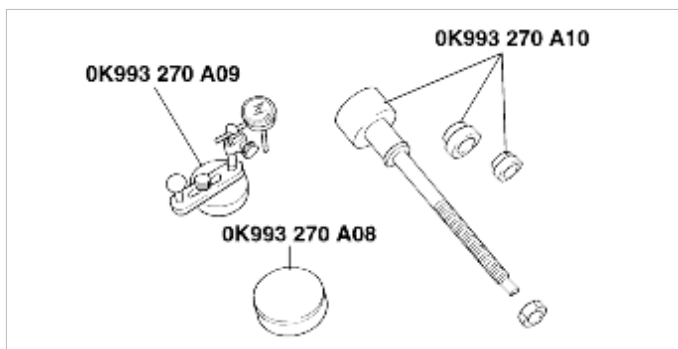

- (2) Assemble spacer and inner bearing inner race to pinion model and fix it with O-ring.

NOTICE

Use spacer disassembled.

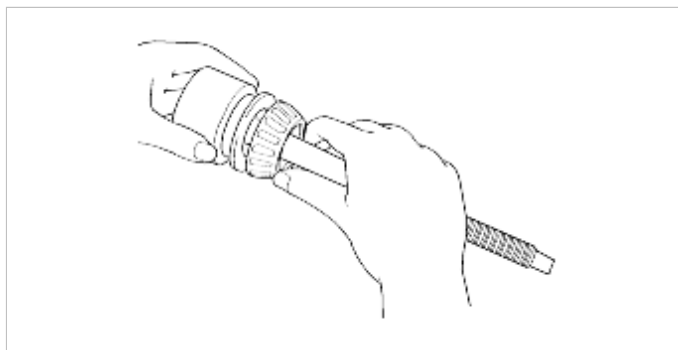

- (3) Install pinion model assembly to carrier.
 (4) Assemble outer bearing, companion flange washer, and lock nut.

NOTICE

Use washer and lock nut disassembled.

- (5) Tighten lock nut.

NOTICE

- Tighten to the extent the companion flange can be screwed by hand.

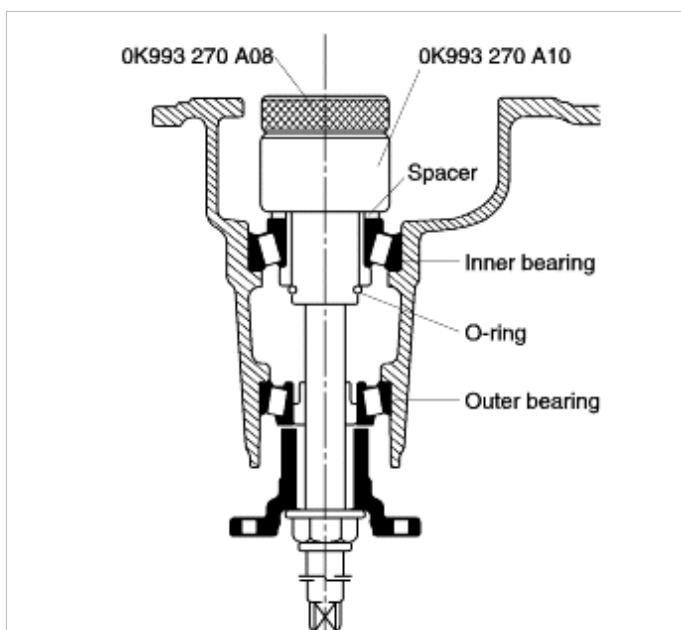

(6) Put pinion height adjusting gauge body at right angle and adjust it to 0.

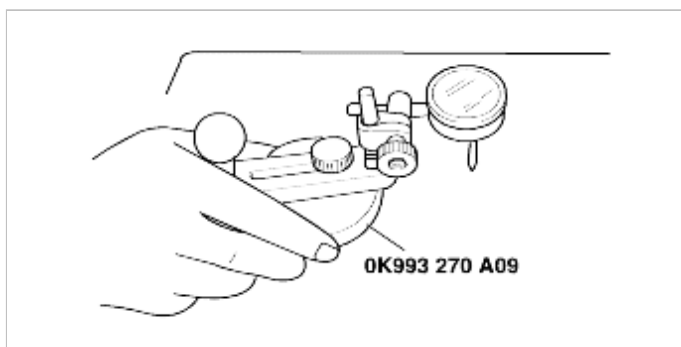

(7) Put pinion height adjusting gauge body and gauge block to the upper side of pinion model.

(8) Dial gauge needle should be placed at the lowest part of side bearing.

(9) Measure minimum positions of both sides (LH, RH).

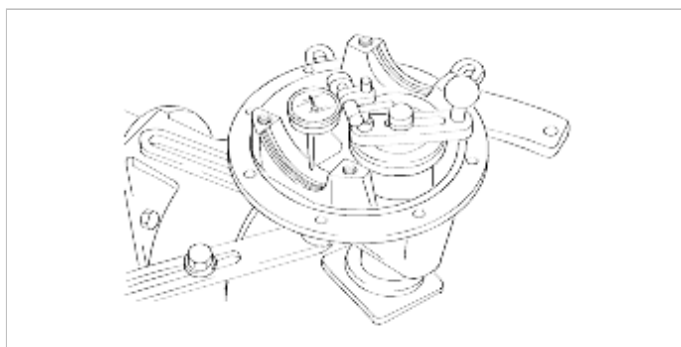

(10) Add both values and divide it by 2.

(11) If the value of the above step 10 is not within specification, use new spacer adding the values to current spacer.

Standard clearance :
-0.025~0.025 mm (-0.001~0.001 in)

MARK	THICKNESS	MARK	THICKNESS
08	3.08(0.1212)	29	3.29(0.1259)
11	3.11(0.1224)	32	3.32(0.1307)

14	3.14(0.1236)	35	3.35(0.1318)
17	3.17(0.1248)	38	3.38(0.1330)
20	3.20(0.1259)	41	3.41(0.1342)
23	3.23(0.1271)	44	3.44(0.1354)
26	3.26(0.1283)	47	3.47(0.1366)

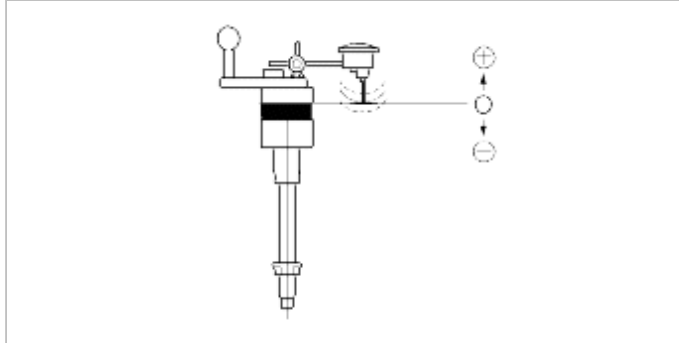

5. Adjustment of drive pinion preload.

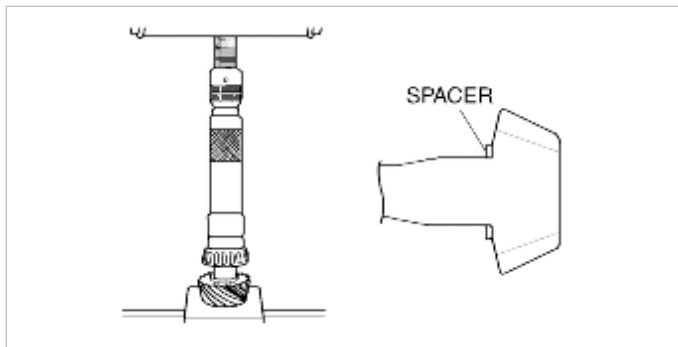

- (1) Install spacer.
- (2) Push inner bearing in using SST.

NOTICE

- Keep pressuring until the sudden increase of necessary power.
- Place the spacer for adjusting pinion height, ensuring exact direction of installation.

- (3) Install distance piece.
- (4) Push outer bearing in using SST.
- (5) Install drive pinion assembly.
- (6) Install companion flange and tighten lock nut.

Tightening torque :
127-284 N·m (13-29 kg·m, 94-210 lb·ft)

NOTICE

Do not install oil seal.

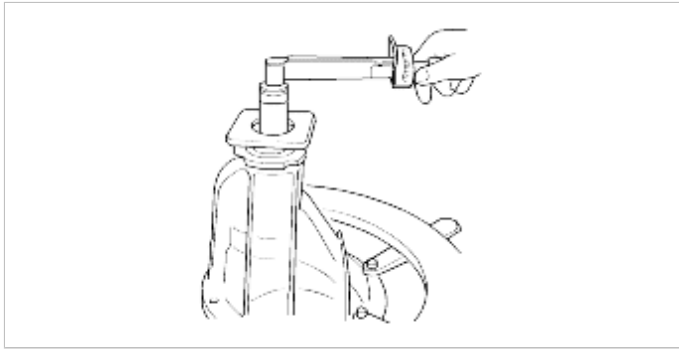

- (7) Turn companion flange by hand so that bearing be put at the right place.
- (8) Measure preload of drive pinion. If the result is not within specification, use new distance piece and measure again.

Preload :
127-176 N·m (13-18 kg·m, 94-130 lb·ft)

- (9) Remove the lock nut and then install the oil seal.
- (10) >Install the companion flange and tighten lock nut.

Tightening torque :
127-284 N·m (13-29 kg·m, 94-210 lb·ft)

6. ADJUSTMENT OF DIFFERENTIAL GEAR BACKLASH

Adjust the differential gear backlash according to the following procedures :

- (1) Assemble the side gears, side gear spacers, pinion gears, and pinion washers into the differential case.
- (2) Temporarily install the pinion shaft.

NOTICE

Do not install the lock pin yet.

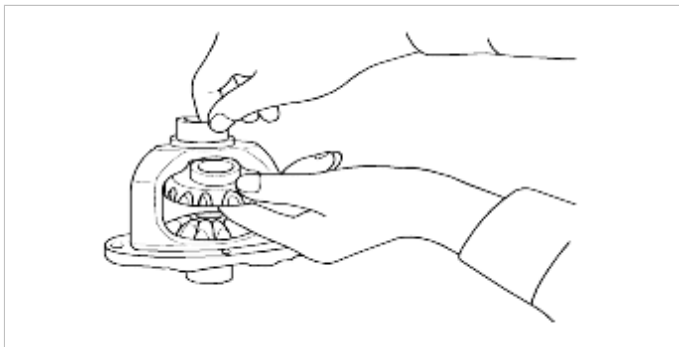

- (3) Insert a wedge in the side gear and measure the differential gear backlash with a dial indicator on the pinion gear.

NOTICE

Measure both pinion gears separately.

Standard value : 0-0.1 mm (0-0.0039 in.)
Limit : 0.2 mm (0.008 in.)

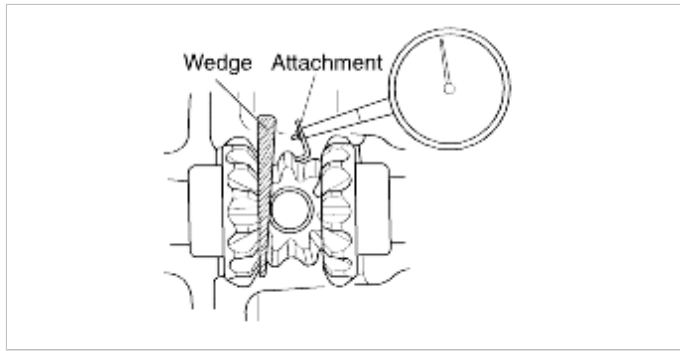

- (4) If the differential gear backlash exceeds the limit, adjust the backlash by selecting thicker side gear thrust spacers.
- (5) Measure the differential gear backlash once again, and confirm that it is within the limit.

NOTICE

- After adjustment, check that the backlash is within the limit and the differential gear rotates smoothly.
- When adjustment is impossible, replace the side gear and the pinion gear as a set.

7. INSTALLATION OF THE LOCK PIN

- (1) Align the pinion shaft lock pin hole with the differential case lock pin hole, and drive in the lock pin.
- (2) Fix the lock pin in place by staking two points around the lock pin hole with a punch.

**8. INSTALLATION OF THE DRIVE GEAR**

- (1) Clean the drive gear attaching bolts.
- (2) Remove the adhesive on the threaded holes of the drive gear use a tap (M10 x 1.25), and then clean the threaded holes with compressed air.

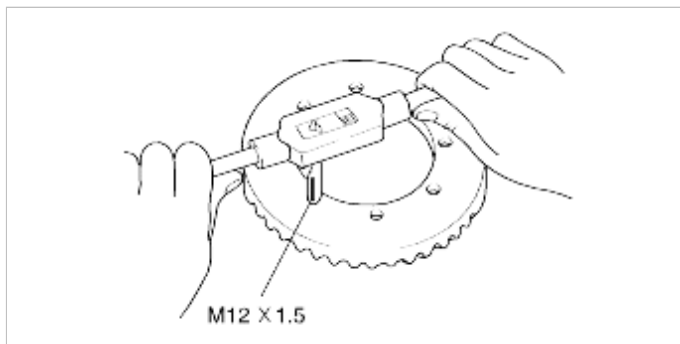

- (3) Apply the specified adhesive to the threaded holes of the drive gear.

Specified adhesive : LOCTITE #262 or equivalent

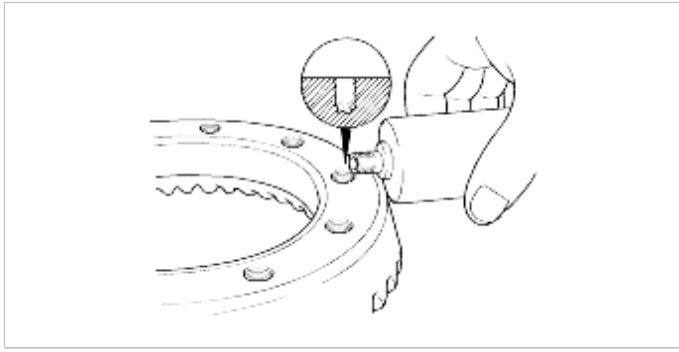

(4) Install the drive gear in the differential case with the matchmarks properly aligned. Tighten the bolts to the specified torque in a diagonal sequence.

9. PRESS THE SIDE BEARING INNER RACE

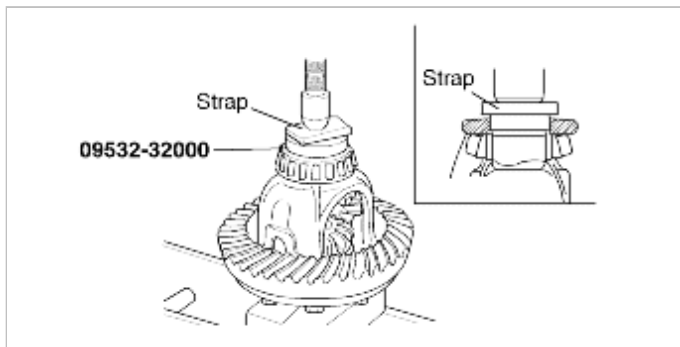

10. Attach actuator at differential case RH side as figure

CAUTION

Take heed of actuator direction.

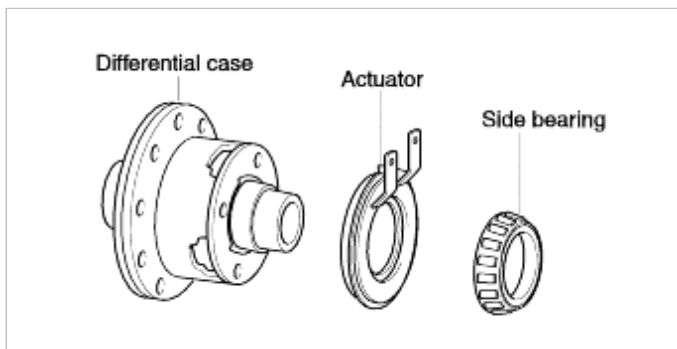

11. ADJUSTMENT OF FINAL DRIVE GEAR BACKLASH

Adjust the final drive gear backlash according to the following procedures :

- (1) Install side bearing spacers which are thinner than those removed, to the side bearing outer races, and then mount the differential case assembly into the gear carrier.

NOTICE

Select side bearing spacers with the same thickness for both the drive pinion side and the drive gear side.

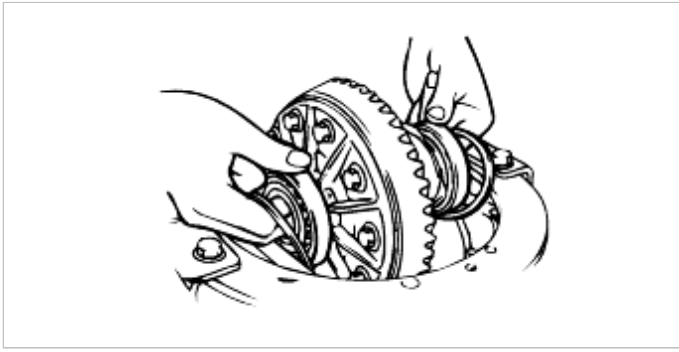

- (2) Push the differential case to one side, and measure the clearance between the gear carrier and the side bearing with a feeler gauge.

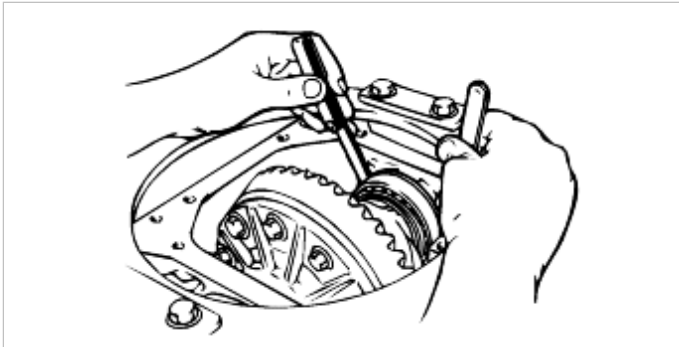

- (3) Select two pairs of spacers, which correspond to the value calculated according to the expression in the illustration. Install one pair each to the drive pinion side and the drive gear side.

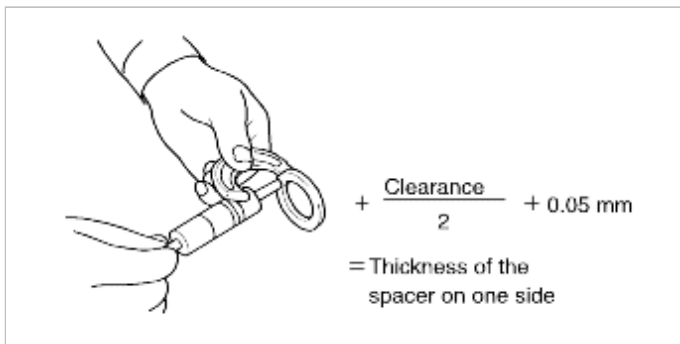

- (4) Install the side bearing spacers and differential case assembly, as shown in the illustration, to the gear carrier.

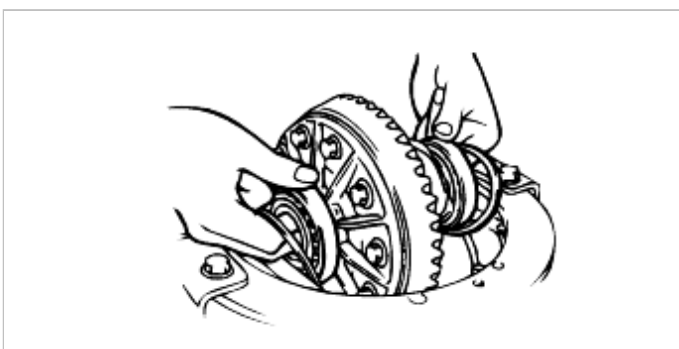

- (5) Tap the side bearing spacers with a brass bar to fit them to the side bearing outer race.

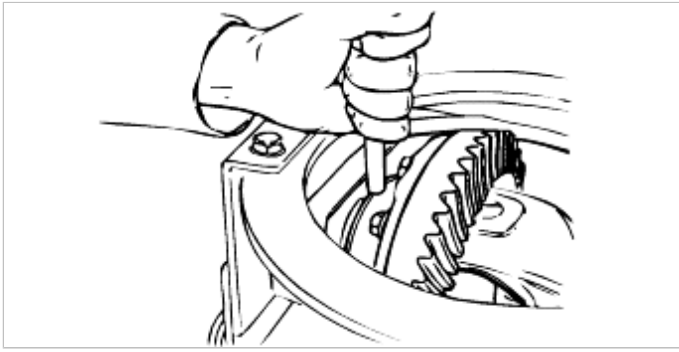

- (6) Align the matchmarks on the gear carrier and the bearing cap and tighten the bearing cap.

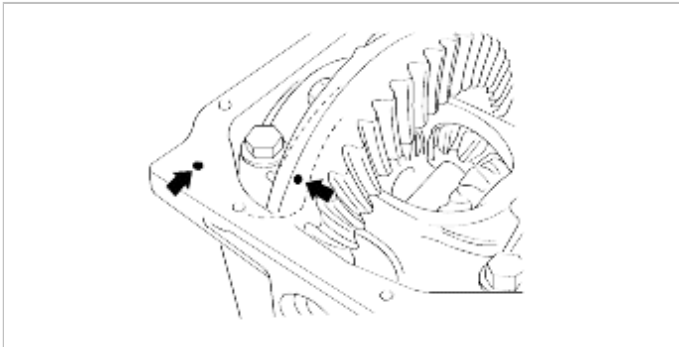

- (7) With the drive pinion locked in place, measure the final drive gear backlash with a dial indicator on the drive gear.

NOTICE

Measure at four points or more on the circumference of the drive gear.

Standard value : 0.09-0.11 mm (0.0035-0.0043 in.)

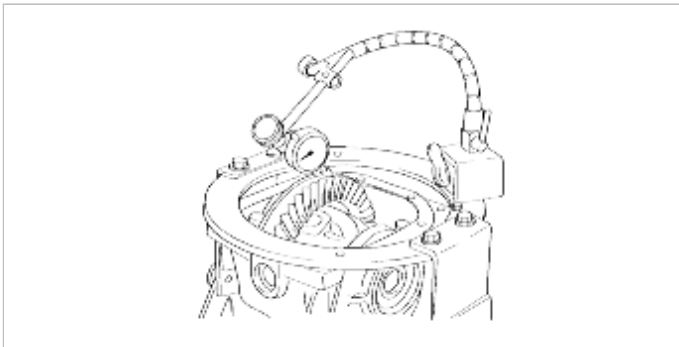

- (8) Change the side bearing spacers as illustrated and then adjust the final drive gear backlash between the drive gear and the drive pinion.

NOTICE

When increasing the number of side bearing spacers, use the same number for each and as few as possible.

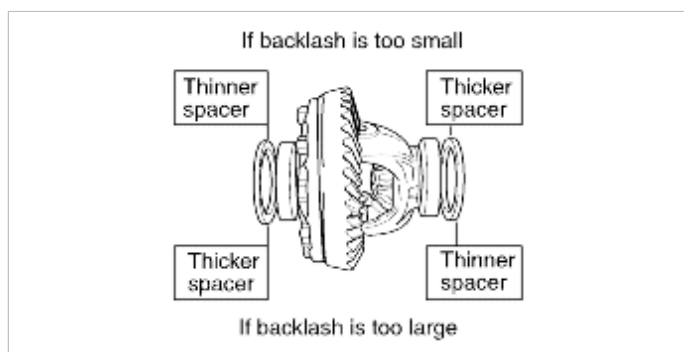

(9) Check the drive gear and drive pinion for tooth contact. If poor contact is evident, adjust again.

(10) Measure the drive gear runout at the shoulder on the reverse side of the drive gear.

Limit : 0.05 mm (0.002 in.)

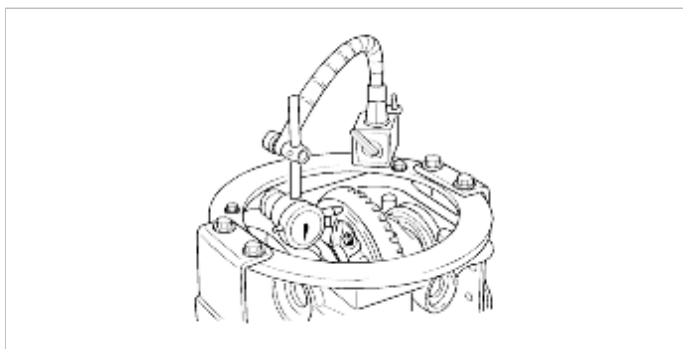

(11) If the drive gear runout exceeds the limit, reinstall by changing the position of the drive gear and differential case, and remeasure.



COMPONENTS

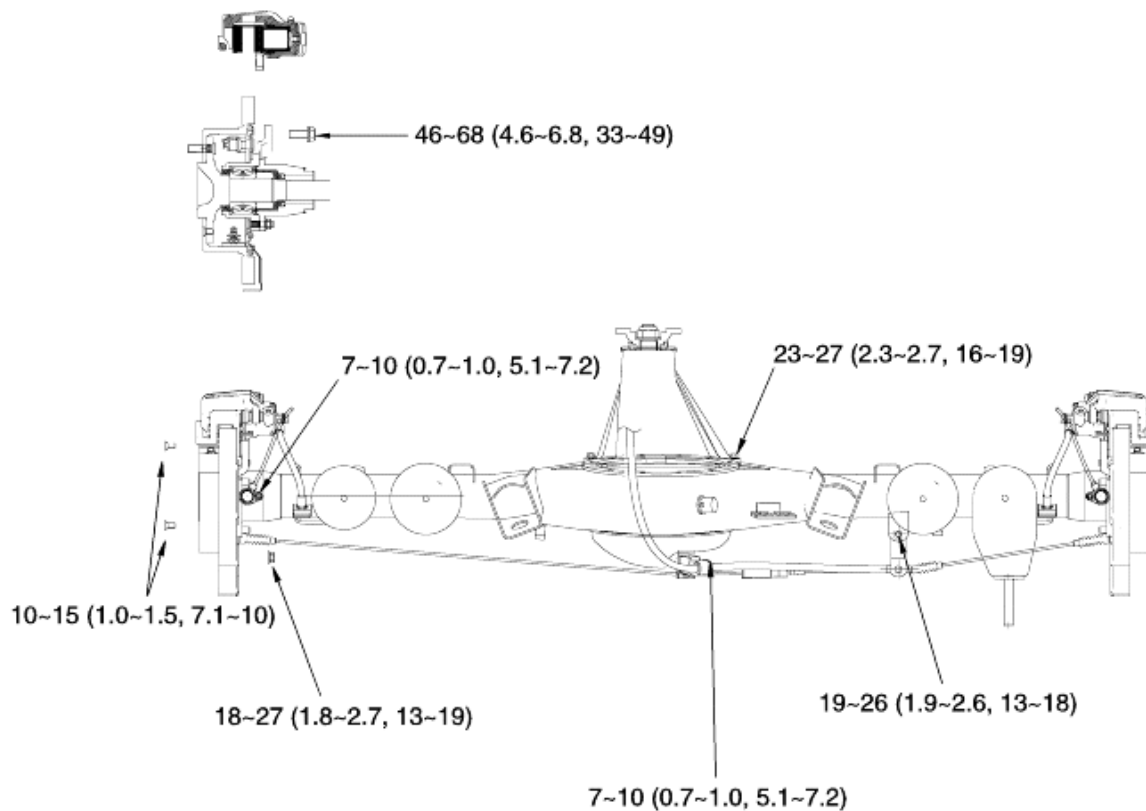

Torque : N·m(kg-m, lb-ft)

REAR DIFFERENTIAL COMPONENTS

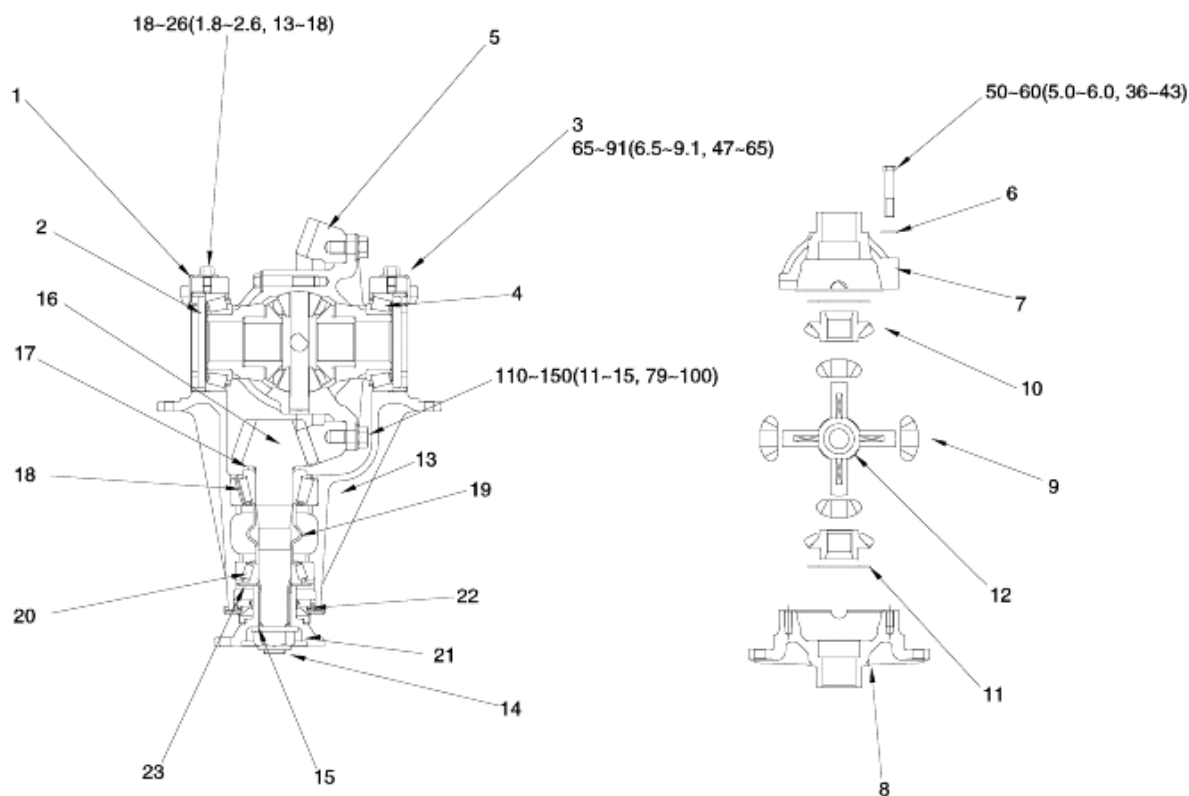
**TORQUE : N-m (kg-m, lb-ft)**

- | | | |
|----------------------------|-------------------------------|----------------------|
| 1. Lock plate | 9. Pinion gear | 17. Spacer |
| 2. Side bearing nut | 10. Side gear | 18. Inner bearing |
| 3. Bearing cap | 11. Side gear thrust washer | 19. Distance piece |
| 4. Side bearing | 12. Spider | 20. Outer bearing |
| 5. Ring gear | 13. Differential carrier case | 21. Companion flange |
| 6. Washer | 14. Lock nut | 22. Oil seal |
| 7. Differential upper case | 15. Lock washer | 23. Oil slinger |
| 8. Differential lower case | 16. Drive pinion | |

2009 > G 3.3 DOHC >

**REMOVAL**

1. Drain the differential gear oil.
2. Remove the rear disk brake.
3. Remove the parking brake and cable.
4. Remove the stabilizer bar.
5. Pull out the rear axle shaft.

CAUTION

Be careful not to damage the oil seal when pulling axle shaft.

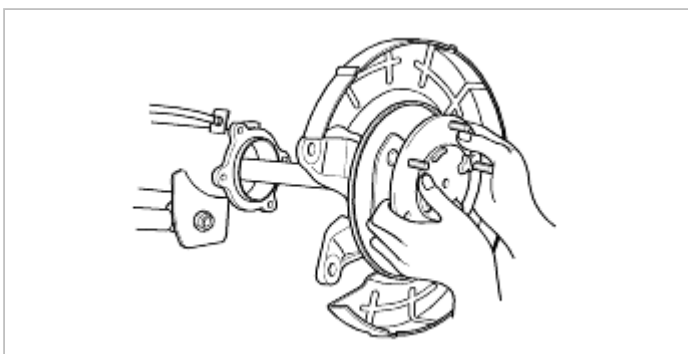

6. After marking the match mark on the flange yoke of the rear propeller shaft and the companion flange of the differential case, remove the rear propeller shaft assembly.

CAUTION

Suspend the propeller shaft from the body with wire, etc.

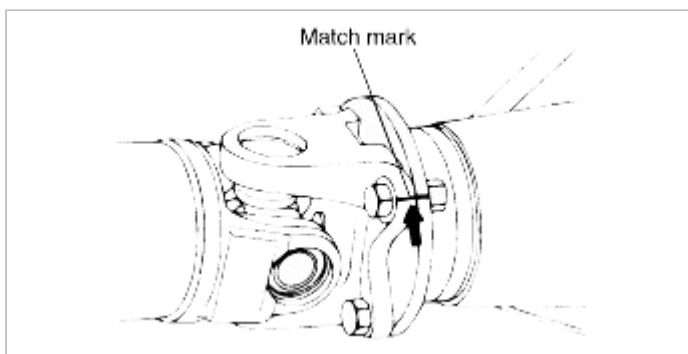

7. Remove the attaching nuts and strike the lower part of differential carrier assembly with a piece of times several times to loosen, then remove the differential carrier assembly.

NOTICE

Use care not to strike the companion flange.

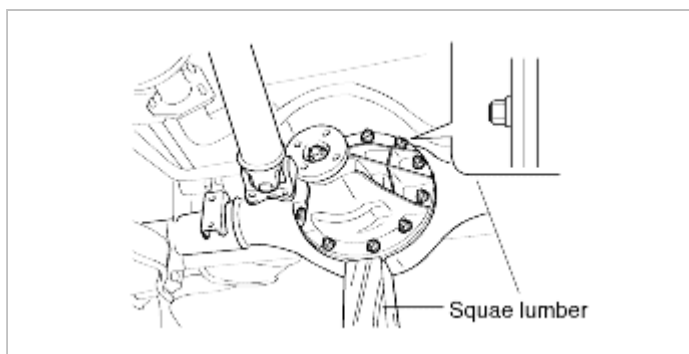

INSTALLATION

1. DIFFERENTIAL CARRIER ASSEMBLY

Apply specified sealant to axle housing flange surface, and install the differential carrier assembly.

Specified sealant : Three bond 1215 or equivalent

Tightening torque :

23-27 Nm (2.3-2.7 kg·m, 16-19 lb·ft)

Specified sealant : Three bond 1215 or equivalent

2. PROPELLER SHART

Align the match marks on the flange yoke and companion flange, and install the propeller shaft.

Tightening torque :

50-60 Nm (500-600 kg·cm, 37-44 lb·ft)

3. AXLE SHAFT ASSEMBLY

(1) Apply specified sealant to the axle housing and bearing case end faces.

Specified sealant : Three bond 1104

DISASSEMBLY

1. SIDE BEARING NUT

NOTICE

Keep the right and left side bearing nuts separate so that they are not mixed during reassembly.

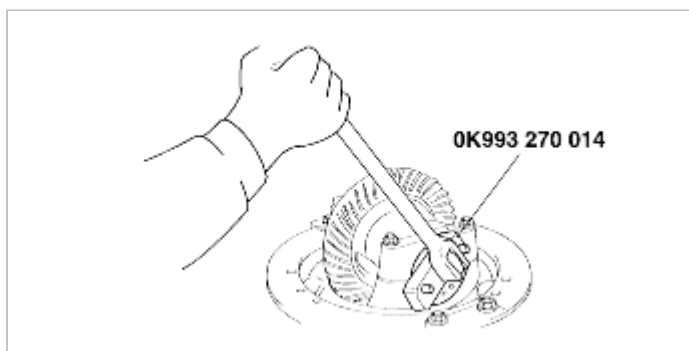

2. REMOVAL OF THE DIFFERENTIAL CASE ASSEMBLY

CAUTION

- Remove the differential case assembly slowly and carefully.
- Be careful so that the side bearing outer race is not dropped.
- Keep the right and left side bearing outer races separate so that they are not mixed during reassembly.

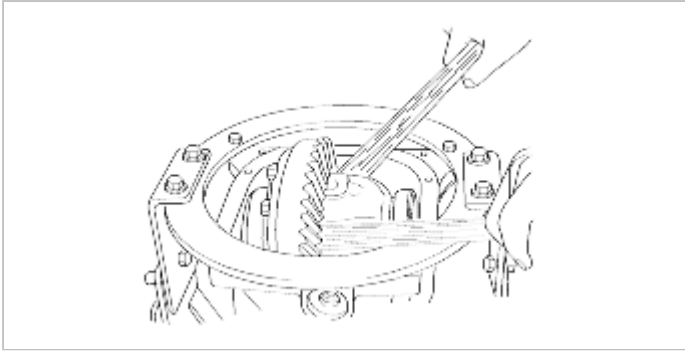

3. REMOVAL OF THE SIDE BEARING INNER RACES

Fit the nut on top of the differential case, and then uses the special tool to remove the side bearing inner race.

NOTICE

Attach the prongs of the special tool (09517-43001) to the inner race of the side bearing through the notched section in the differential case.

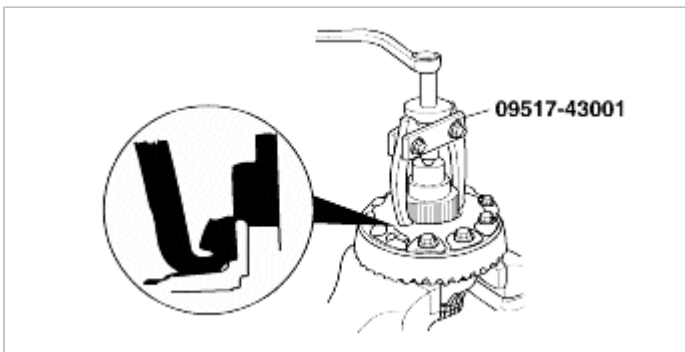

4. REMOVAL OF DRIVE GEAR

- Make the match marks to the differential case and the drive gear.
- Loosen the drive gear attaching bolts in diagonal sequence to remove the drive gear.

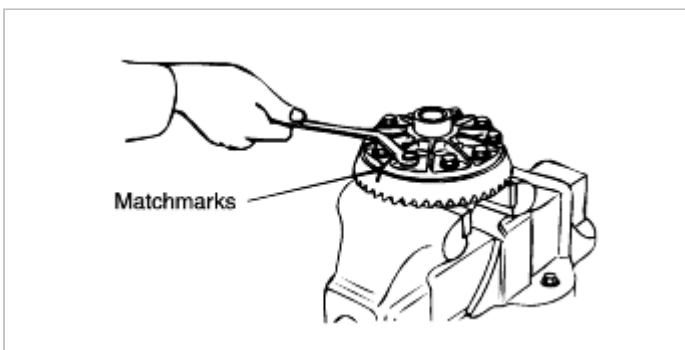

5. REMOVAL THE LOCK NUT

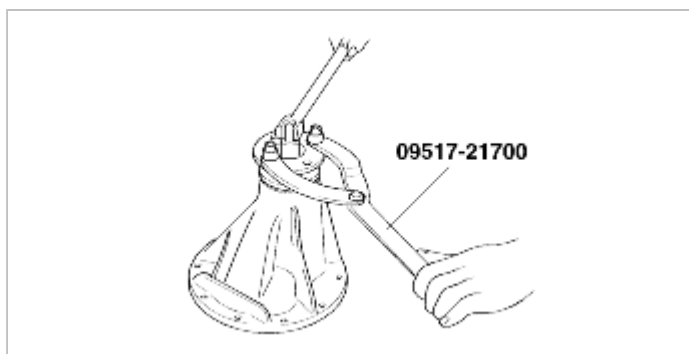

6. REMOVAL OF DRIVE PINION

A. Make the match marks on the drive pinion and companion flange.

CAUTION

Match marks should not be made on the contact surfaces of the companion flange and the propeller shaft.

B. Drive out the drive pinion together with the drive pinion spacer and drive pinion front shims.

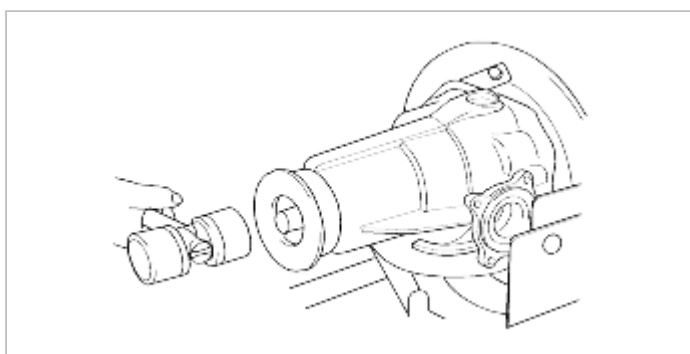

7. REMOVAL OF DRIVE PINION REAR BEARING INNER RACE

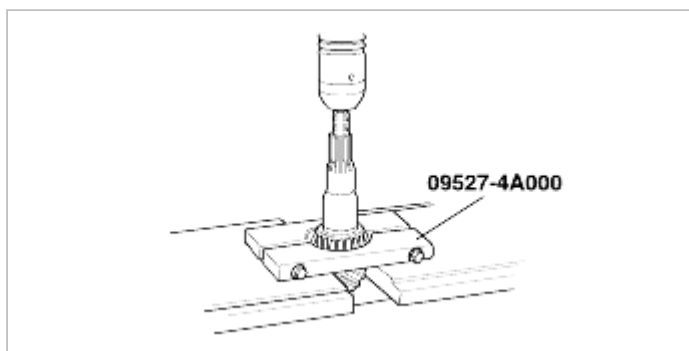

8. REMOVAL OF OIL SEAR / DRIVE PINION FRONT BEARING INNER RACE / DRIVE PINION FRONT BEARING OUTER RACE

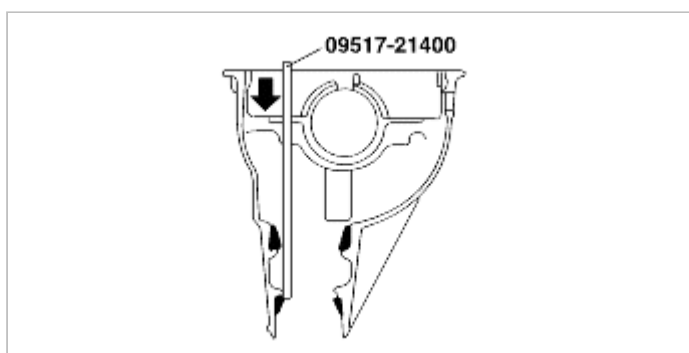

9. REMOVAL OF DRIVE PINION REAR BEARING OUTER RACE

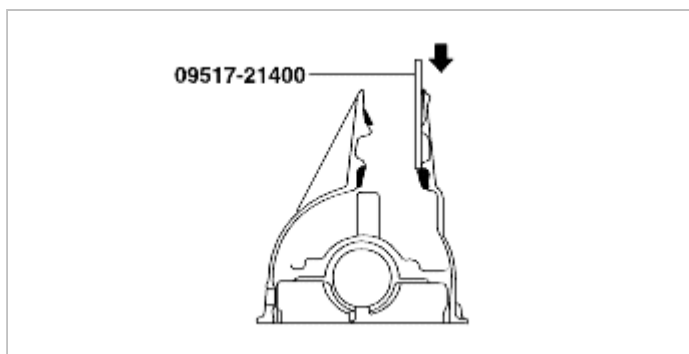

INSPECTION BEFORE DISASSEMBLY

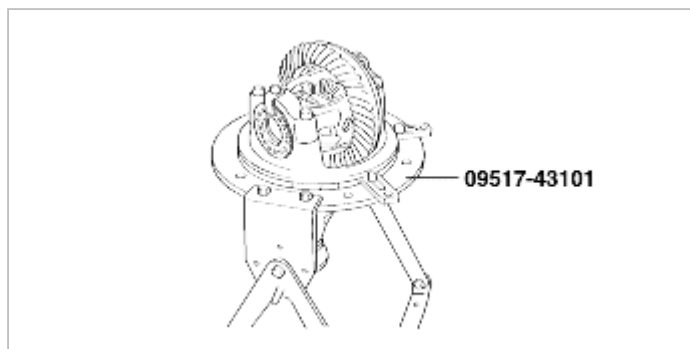

1. FINAL DRIVE GEAR BACKLASH

Check the final drive gear backlash by the following procedure.

- (1) Place the drive pinion and move the drive gear to check backlash is within the standard range.

NOTICE

Measure at 4 points on the gear periphery.

Standard value

0.13-0.18 mm (0.0051-0.0071 in.)

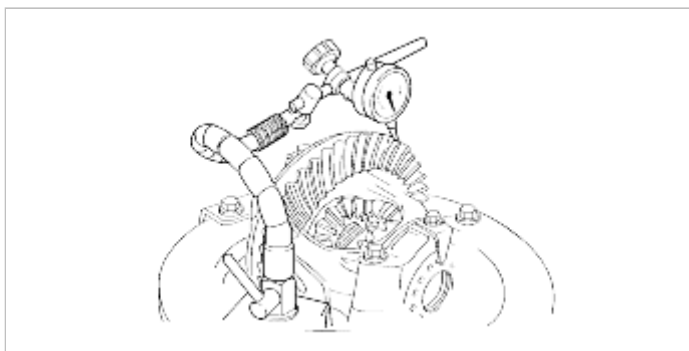

- (2) Adjust with the side bearing nuts if backlash values are not within standard range.

NOTICE

After adjusting, check the state of the final drive gear's tooth contact.

2. DRIVE GEAR RUNOUT

Check the back-face lash as follows:

- (1) Place a dial gauge on the back-face of the drive gear and measure the runout.

Limit : 0.05mm (0.0020in.)

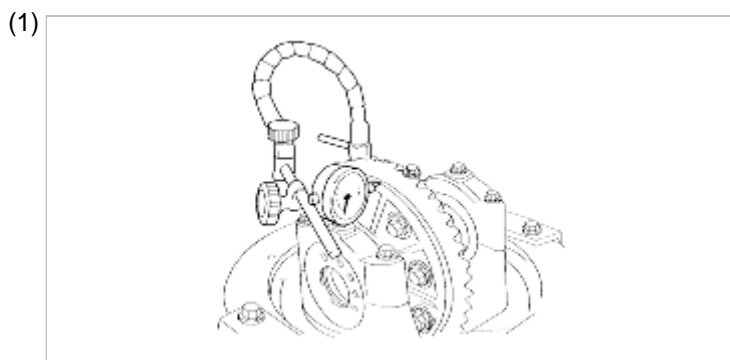

- (2) If the run out is beyond the limit, check that there are no foreign substances between the drive gear and differential case and, that the bolts fixing the drive gear are not loose.

3. DIFFERENTIAL GEAR BACKLASH

- (1) Fix the side gear with a wedge so it cannot move and measure the differential gear backlash with a dial indicator on the pinion gear.

NOTICE

Take the measurements at two places on the pinion gear.

Standard value : 0-0.1 mm (0-0.0039 in.)

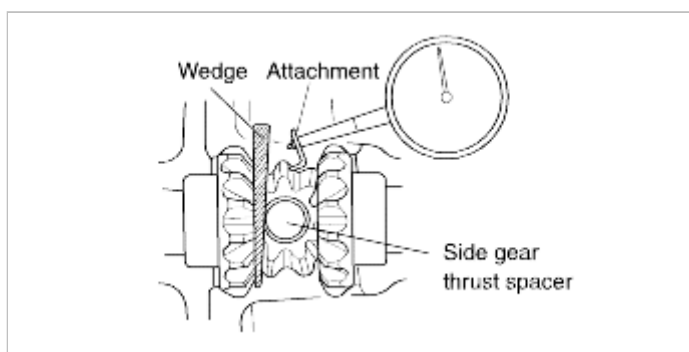

- (2) If the backlash exceeds the limit, adjust using side bearing spacers.

NOTICE

If adjustment is impossible, replace the side gear and pinion gears as a set.

4. FINAL DRIVE GEAR TOOTH CONTACT

Check the final drive gear tooth contact by following the steps below :

- (1) Apply the same amount of machine blue slightly to both surfaces of the drive gear teeth.

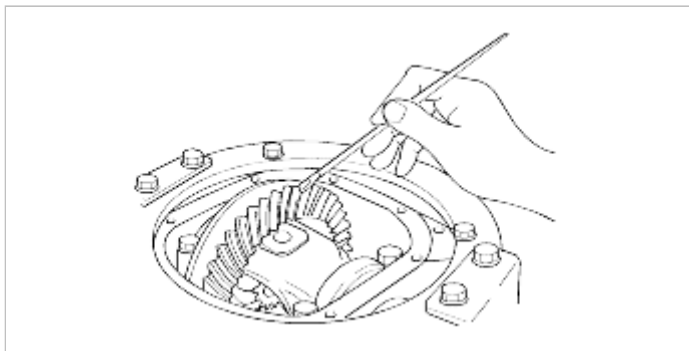

- (2) Insert a brass rod between the differential carrier and the differential case, and then rotate the companion flange by hand (once in the normal direction, and then once in the reverse direction) while applying a load

to the drive gear so that some torque (approximately 25-30kg-cm) is applied to the drive pinion.

CAUTION

If the drive gear is rotated too much, the tooth contact pattern will become unclear and difficult to check.

(3) Check the tooth contact pattern.

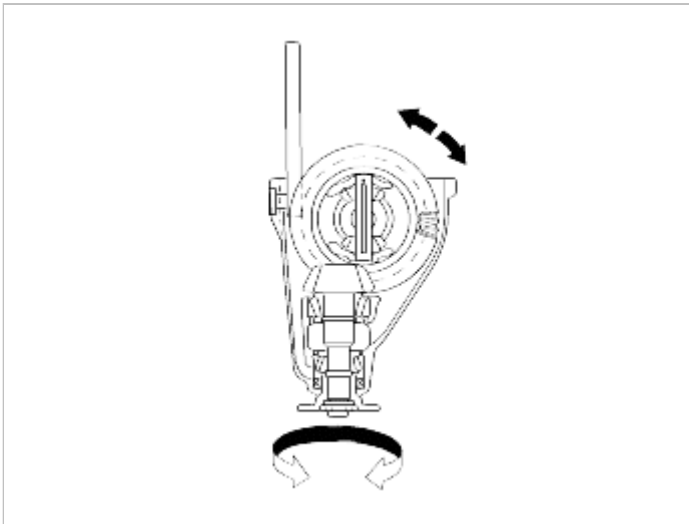

<ol style="list-style-type: none"> 1. Narrow tooth side 2. Drive-side tooth surface (the side receiving power during acceleration) 3. Wide tooth side 4. Coast-side tooth surface (the side receiving power during coast-down) 	
Problem	Solution
Tooth contact pattern resulting from excessive pinion height	
The drive pinion is positioned too far from the center of the drive gear.	Also, for backlash adjustment, reposition the drive gear further from the drive pinion.
Tooth contact pattern resulting from insufficient pinion height	

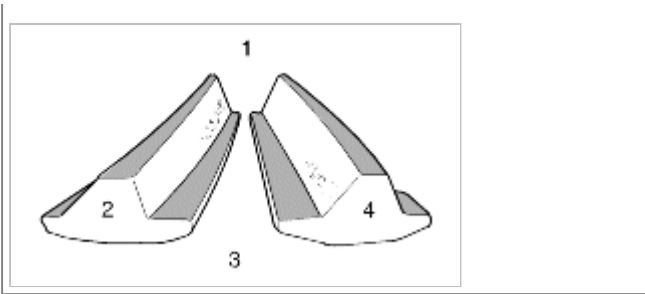
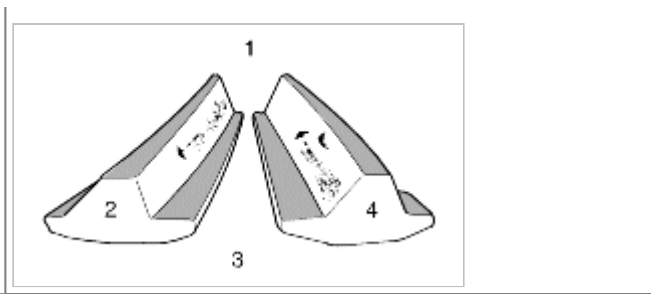
	
<p>The drive pinion is positioned too close to the center of the drive gear.</p>	<p>Decrease the thickness of the pinion height adjusting shim, and position the drive pinion further from the center of the drive gear. Also, for backlash adjustment, reposition the drive gear closer to the drive pinion.</p>

NOTICE

- Tooth contact pattern is a method for judging the result of the adjustment of drive pinion height and final drive gear backlash. The adjustment of drive pinion height and final drive gear backlash should be repeated until the tooth contact patterns are similar to the standard tooth contact pattern.
- When you cannot obtain a correct pattern, the drive gear and drive pinion have exceeded their limits. Both gears should be replaced as a set.

INSPECTION

1. Check the companion flange for wear or damage.
2. Check the bearings for wear or discoloration.
3. Check the gear carrier for cracks.
4. Check the drive pinion and drive gear for wear or cracks.
5. Check the side gears, pinion gears and pinion shaft for wear or damage.
6. Check the side gear spline for wear or damage.
7. Check the length of the distance piece.

Standard length :
54.80-58.09 mm (2.16-2.21 in.)

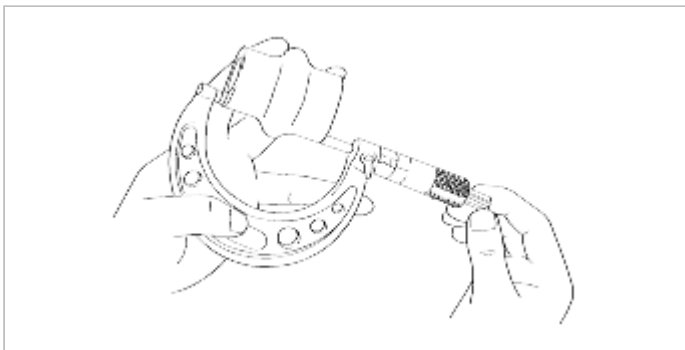
**REASSEMBLY**

1. Install the drive pinion rear bearing outer race and drive pinion front bearing outer race using the special tools (09500-11000, 09500-21000, 09532-31200B and 09532-32000).

CAUTION

Be careful not to press in the outer race when it is inclined.

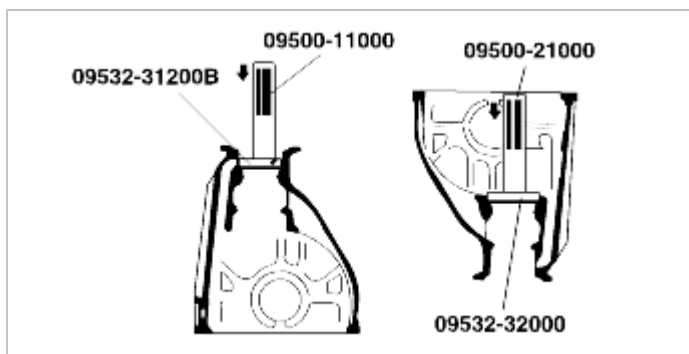

2. ADJUSTMENT OF PINION HEIGHT

Adjustment the drive pinion height by the following procedure.

- (1) For assembly of pinion, use drive pinion model (OK993 270 A01), pinion height adjustment gauge body (OK993 270 A09) and gauge block (ht. 28 mm (1.102 in)).

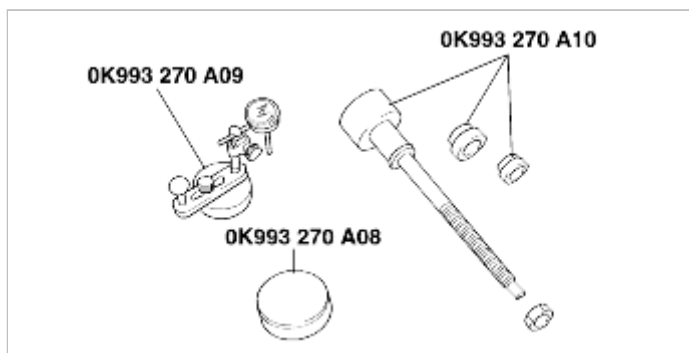

- (2) Assemble spacer and inner bearing inner race to pinion model and fix it with O-ring.

NOTICE

- Use spacer disassembled.

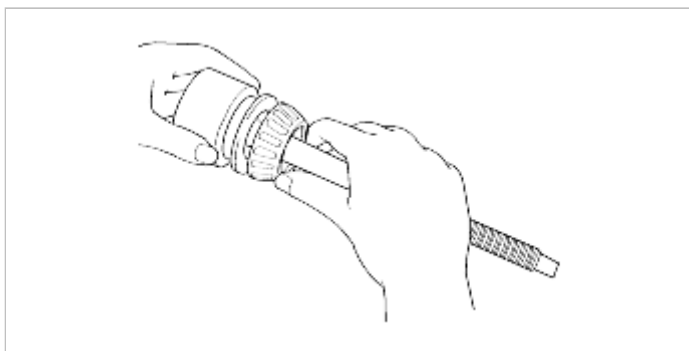

- (3) Install pinion model assembly to carrier.

- (4) Assemble outer bearing, companion flange washer, and lock nut.

NOTICE

- Use washer and lock nut disassembled.

- (5) Tighten lock nut.

NOTICE

- Tighten to the extent the companion flange can be screwed by hand.

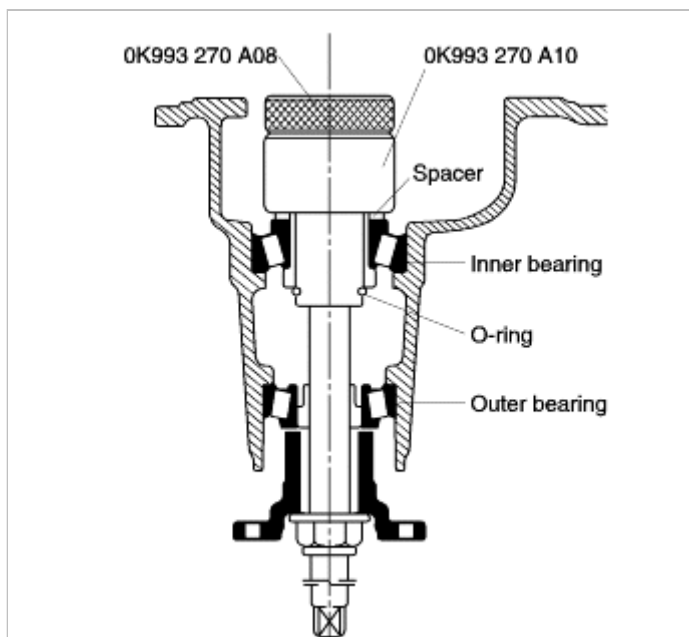

(6) Put pinion height adjusting gauge body at right angle and adjust it to 0.

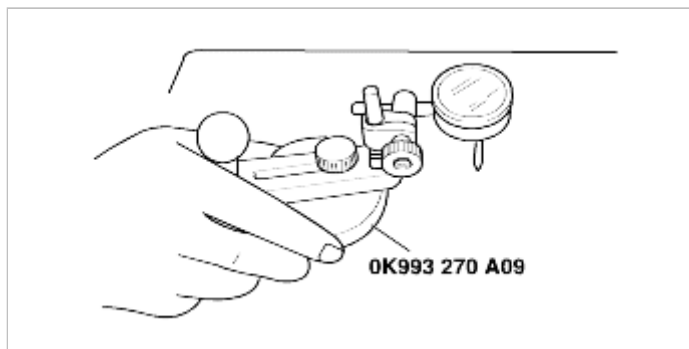

(7) Put pinion height adjusting gauge body and gauge block to the upper side of pinion model.

(8) Dial gauge needle should be placed at the lowest part of side bearing.

(9) Measure minimum positions of both sides (LH, RH).

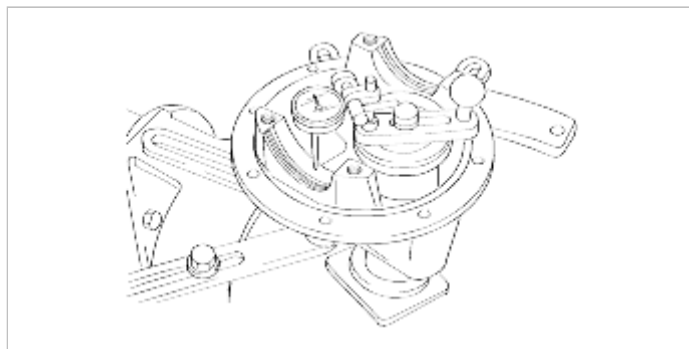

(10) Add both values and divide it by 2.

(11) If the value of the above step 10 is not within specification, use new spacer adding the values to current spacer.

Standard clearance :
-0.025~0.025 mm (-0.001~0.001 in)

MARK	THICKNESS	MARK	THICKNESS
08	3.08(0.1212)	29	3.29(0.1259)

11	3.11(0.1224)	32	3.32(0.1307)
14	3.14(0.1236)	35	3.35(0.1318)
17	3.17(0.1248)	38	3.38(0.1330)
20	3.20(0.1259)	41	3.41(0.1342)
23	3.23(0.1271)	44	3.44(0.1354)
26	3.26(0.1283)	47	3.47(0.1366)

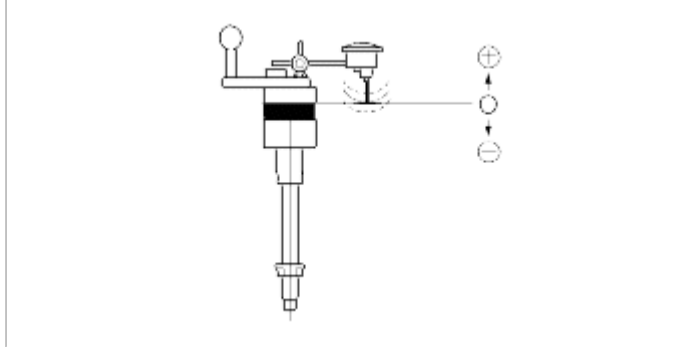

3. Adjustment of drive pinion preload.

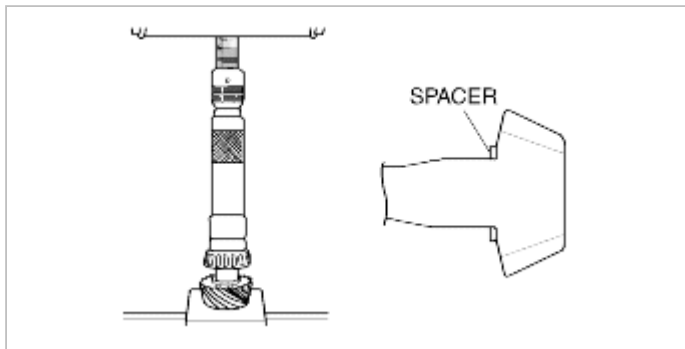

- (1) Install spacer.
- (2) Push inner bearing in using SST.

NOTICE

- Keep pressuring until the sudden increase of necessary power.
- Place the spacer for adjusting pinion height, ensuring exact direction of installation.

- (3) Install distance piece.
- (4) Push outer bearing in using SST.
- (5) Install drive pinion assembly.
- (6) Install companion flange and tighten lock nut.

Tightening torque :
127-284 N·m (13-29 kg·m, 94-210 lb·ft)

NOTICE

- Do not install oil seal.

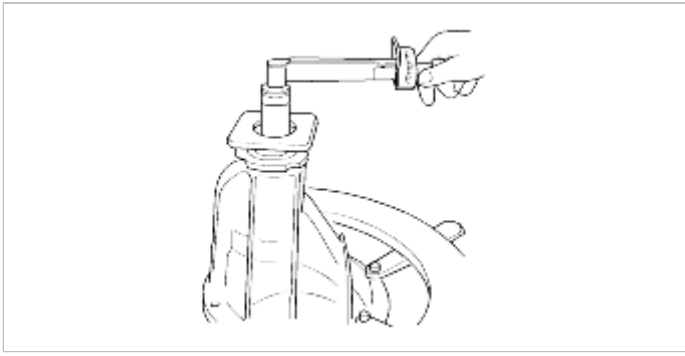

- (7) Turn companion flange by hand so that bearing be put at the right place.
- (8) Measure preload of drive pinion. If the result is not within specification, use new distance piece and measure again.

Preload :
127-176 N·m (13-18 kg·cm, 94-130 lb·ft)

- (9) Remove the lock nut and then install the oil seal.
- (10) Install the companion flange and tighten lock nut.

Tightening torque :
127-284 N·m (13-29 kg·m, 94-210 lb·ft)

ADJUSTMENT OF DIFFERENTIAL GEAR BACKLASH

1. Assemble the side gears, side gear spacers, pinion gears, and pinion washers into the differential case.
2. Temporarily, install the pinion shaft.

NOTICE

Do not install the lock pin yet.

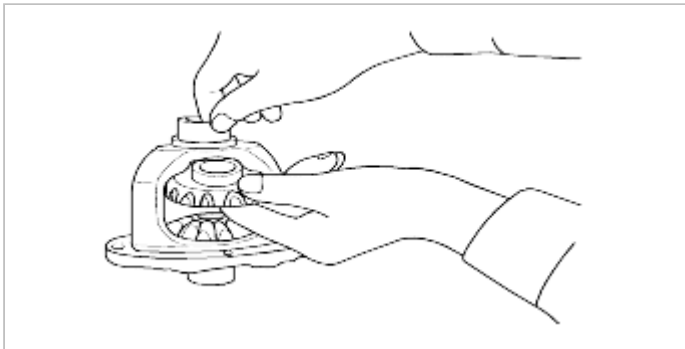

3. Insert a wedge in the side gear and measure the differential gear backlash with a dial indicator on the pinion gear.

NOTICE

Measure both pinion gears separately.

Standard value : 0-0.1 mm (0-0.0039 in.)
Limit : 0.2 mm (0.008 in.)

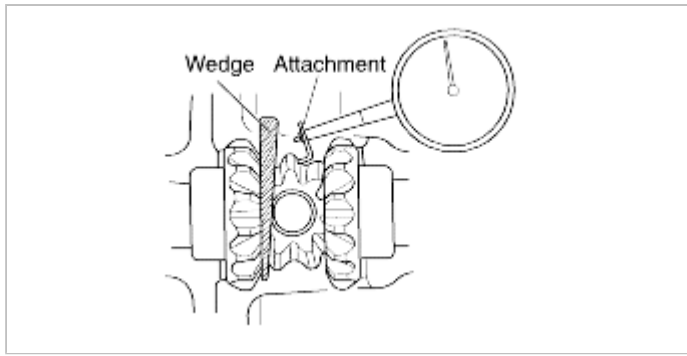

4. If the differential gear backlash exceeds the limit, adjust the backlash by installing thicker side gear thrust spacers.
5. Measure the differential gear backlash once again, and confirm that it is within the limit.

NOTICE

- After adjustment, check that the backlash is within the limit and the differential gear rotates smoothly.
- When adjustment is impossible, replace the side gear and the pinion gear as a set.

6. Installation of the drive gear
 - A. Clean the drive gear attaching bolts.
 - B. Remove the adhesive on the threaded holes of the drive gear with a tap (M12 x 1.5), and then clean the threaded holes with compressed air.

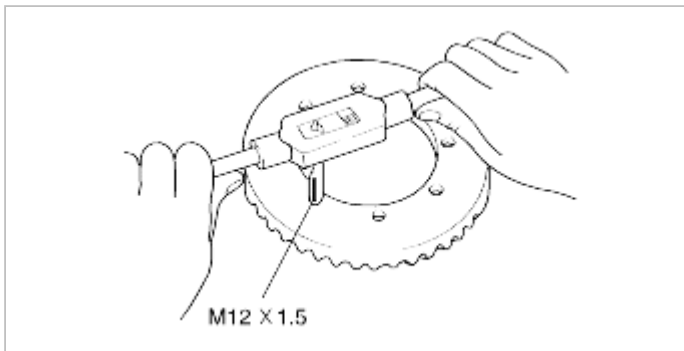

- C. Apply the specified adhesive to the threaded holes of the drive gear.

Specified adhesive :
LOCTITE #262 or equivalent

- D. Install the drive gear in the differential case with the matchmarks properly aligned. Tighten the bolts to the specified torque (11-15 kg·m) in a diagonal sequence.

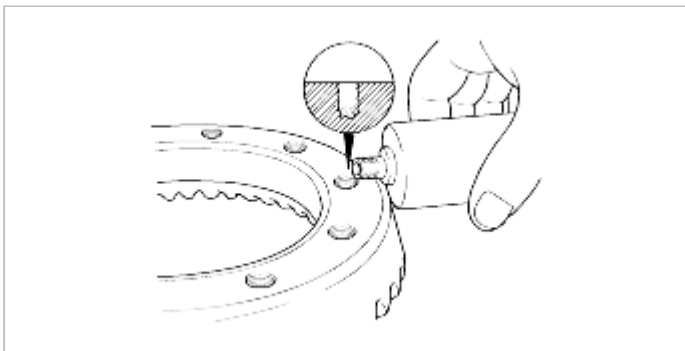

7. Press-fit the side bearing inner race

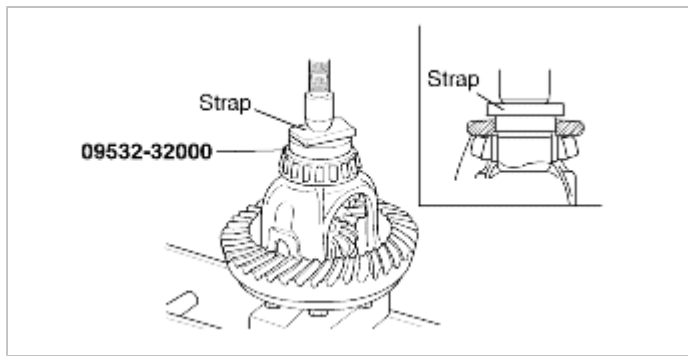

8. Align the match mark on the gear carrier and the bearing cap, and then tighten the bearing cap.

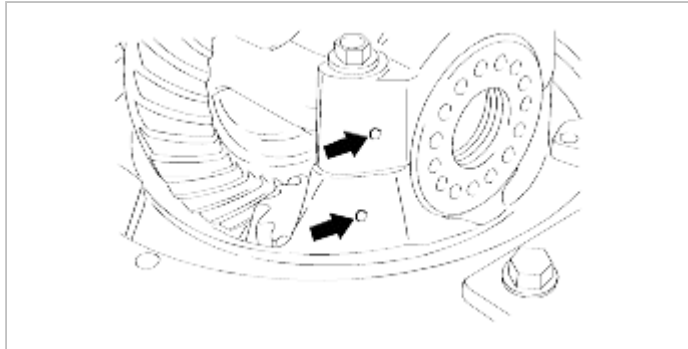

9. ADJUSTMENT OF FINAL DRIVE GEAR BACKLASH

Adjust final drive gear backlash as follows :

- (1) Using the special tool (09521-43001), temporarily tighten the side bearing nut until it is in the state just before preloading of the side bearing.

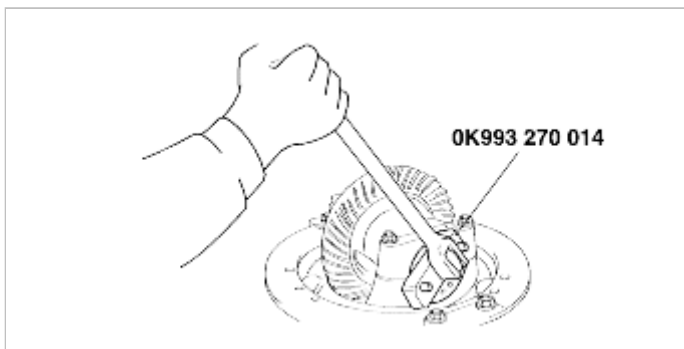

- (2) Measure the final drive gear backlash.

Standard value :
0.13-0.18mm (0.0051-0.0071 in.)

NOTICE

Measure at least 4 points on the drive gear periphery.

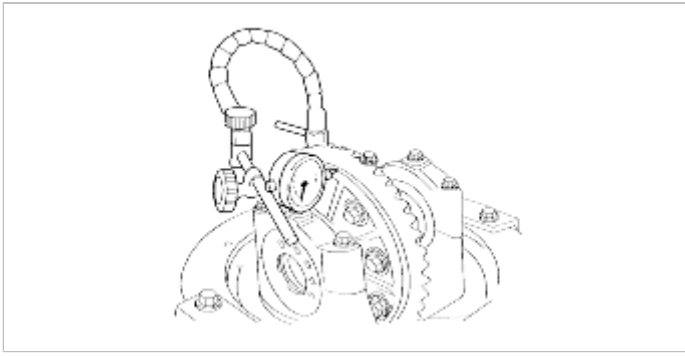

- (3) Using the special tool (09521-43000), adjust the backlash to standard value by moving the side bearing nut as shown.

NOTICE

First turn the side bearing nut for loosening, and then turn (by the same amount) the side bearing nut for tightening.

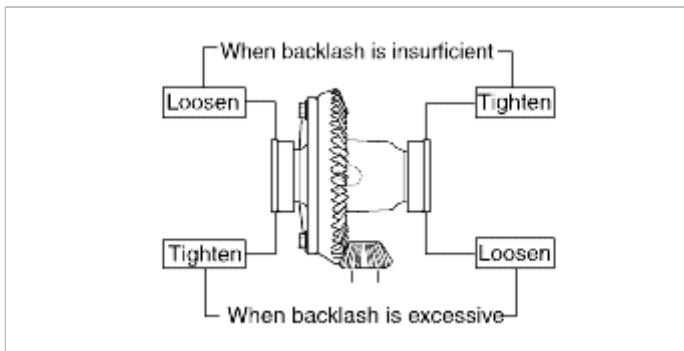

- (4) Using the special tool (09521-43001) to apply the preload, turn down both right and left side bearing nut on half the distance between centers of two neighboring holes.

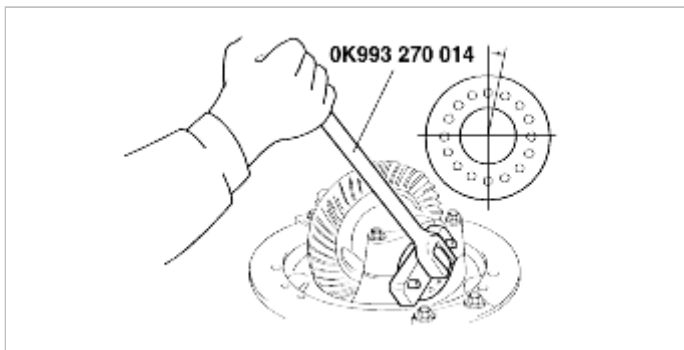

- (5) Choose and install the lock plates two kinds.

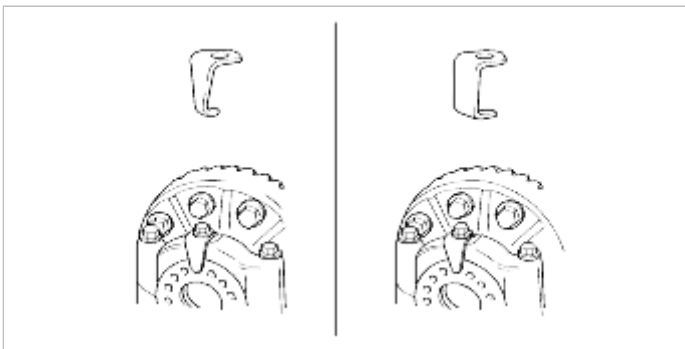

- (6) Check the final drive gear tooth contact. If poor contact is evident, make adjustment.
 (7) Measure the drive gear run out.

Limit : 0.05mm (0.0020in.)

- (8) When drive gear run out exceeds the limit, remove the differential case and then the drive gears, moving them to different positions and reinstalling them.

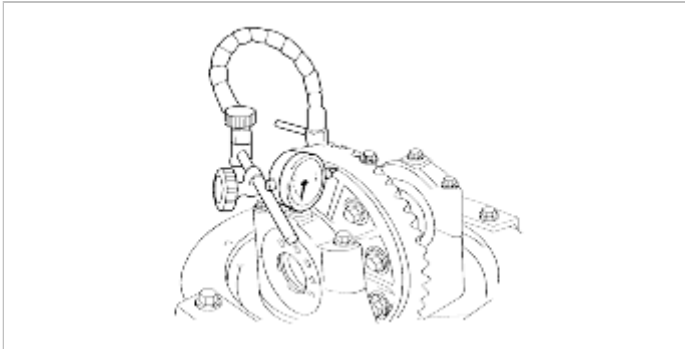

2009 > G 3.3 DOHC >



COMPONENTS

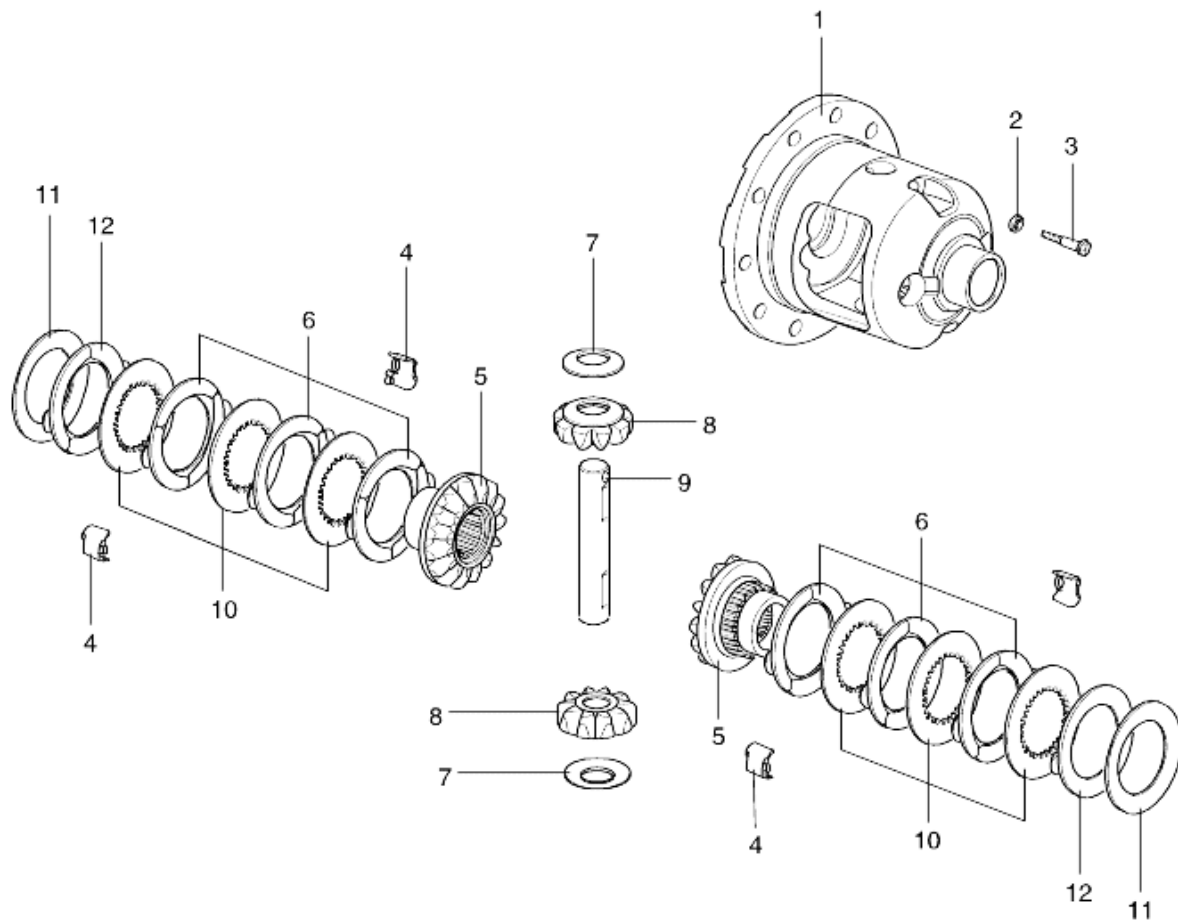

- | | |
|--|---|
| 1. Case | 7. Thrust washer-pinion |
| 2. Washer-lock | 8. Pinion gear |
| 3. Screw-lock | 9. Cross shaft-pinion |
| 4. Guide-ear | 10. Disc-splined friction |
| 5. Gear-side | 11. Shim-side gear |
| 6. Eared disc S/A (carbon on both sides) | 12. Eared disc S/A (carbon on one side) |



DISASSEMBLY

1. Remove the threaded lock screw and the cross shaft.
2. Without preload on the side gears they can be turned by hand. Rotate the side gears until the pinions are in the window area. Remove the pinions and pinion thrust washers.
3. Remove the gear sub-assemblies (side gear, disc pack, ear guides and disc pack shims). Do not mix parts. Identify the parts so they can be reassembled to the original location.

INSPECTION

1. Check the side gears, pinions, pinion thrust washers, and cross shaft for wear or damage. If there is excessive wear, cracks, nicks, grooves or galling replace the parts.
2. Inspect the carbon surfaces. After cleaning with a solvent, the carbon surface should appear like a coarse weave fabric with flat spots on the peaks of the weave. If the surface is smooth, either from wear or from the weave filled with debris replaces the entire disc pack.
3. Measure the thickness of the carbon friction discs. If any of the double sided discs are less than 2.56 mm (0.101in.) or the single sided disc is less than 2.15mm (0.085 in.), replace the entire disc pack.
4. Inspect the splined friction discs. If they have grooves or a mirror like finishing, replacing the entire disc pack. Small scratches on a buff like finish are okay.

REASSEMBLY AND SHIM SELECTION

1. Apply axle lubricant to all sliding surfaces. Be especially careful to coat the mating surfaces of the friction discs.
2. Starting with a double sided eared disc next to the side gear, stack four eared discs and three splined discs on to the spline of side gear. A splined disc goes in between each eared disc with the last eared disc being single sided and the carbon surface facing the side gear. Use a heavy bearing grease in the ear guides to hold them in place during assembly.

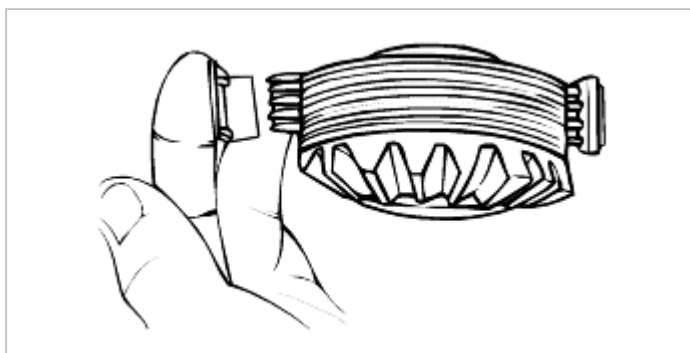

3. Select a shim 0.76mm (0.030in.) thick and place on the hub side of the disc pack subassembly.
4. Lubricate and assemble the other side gears as above.
5. Install the flange end side gear subassembly and shim in the flange end of the differential case.
6. Position pinion gears and thrust washers on the side gears and install the cross shaft through the case and pinions.
7. Install a dial indicator on the case so that the indicator tip rests against a pinion tooth face.
8. Compress the clutch pack with a large screwdriver or pry bar as shown. Rotate the pinion gear back and forth to obtain backlash. Tooth backlash should be 0 to 0.10mm (0 to 0.004in.). If required, change the 0.76mm (0.30in.) Shim to obtain the proper backlash.

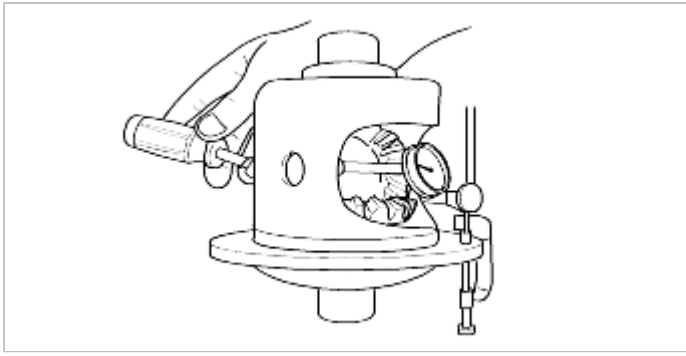

9. Remove the side gear subassembly and repeat the tooth backlash procedure for the other gear pack on the opposite side of the case.
10. Remove the cross shaft, pinions and thrust washers and reinstall the first side gear subassembly and shim in the flange end of the case.
11. Install a pinion and thrust washer through each window so that the gear teeth mesh and so that the pinions are in line with each other. Rotate one side gear so the pinions and thrust washers rotate at a position where they line up with the cross shaft holes in the case.
12. Install the pinion shaft, lock screw and lock washer. Tighten the lock screw to 30-40Nm (3.1~4.1 kg·m, 22-29lb·ft) torque.