



جزوه آموزشی موتور خودرو آریزو ۵



Code: ELC-87-04

Item	Specification	
Engine Type	Vertical, in-line 4-cylinder, 16 valves, water-cooled, 4-stroke, DOHC, electronic controlled sequential multiport fuel injection, Variable Valve Timing (VVT), Variable Intake System (VIS)	
Engine Model	SQRE4G15B	
Valve Number Per Cylinder	4	
Cylinder Center Distance	83	
Cylinder Diameter (mm)	77	
Piston Stroke (mm)	80.5	
Displacement (L)	1.499	
Compression Ratio	11:1	
Combustion Chamber Type	Hemispherical	
Fuel Supply Type	Electronic controlled sequential multiport fuel injection	
Ignition Type	Ignite	
Ignition Sequence	1-3-4-2	
Rated Power (kW)	85	
Rated Power Speed (r/min)	6150	
Max. Torque (N·m)	141	
Max. Torque Speed (r/min)	3800	
Min. Fuel Consumption Rate (g/kW·h)	250	
Fuel Octane Number (Not Less Than)	Unleaded gasoline, octane number 93	
Oil Octane Number	In summer	SAE 10W - 40 (SM grade or higher)
	In winter	SAE 5W - 40 (SM grade or higher)
Oil Capacity (L)	New engine	5.3 ± 0.2
	After oil filter is replaced	4.7 ± 0.2
Crankshaft Rotation Direction	Counterclockwise (viewed from end surface of engine flywheel)	
Starting Type	Electrical starting	
Cooling Type	Forced circulation type antifreeze cooling	
Lubrication Type	Compound type (pressure, splash lubrication)	
Fuel Pressure (bar)	4	
Cylinder Compression Pressure (bar) (180 - 250) r/min	9 - 11.5	

Item	Specification	
Oil Pressure (kPa)	Low idling speed (700 ± 50 r/min)	Not less than 70
	Speed (2000 r/min when oil temperature is 90°)	Not less than 250
Thermostat Operation Temperature (°C)	Open temperature	82 ± 2
	Full open temperature	95
Starting Performance	With coolant temperature at -30°C, engine can start smoothly within 8 seconds without taking special measures. Starting test shows that starting can be performed 3 times consecutively. If it fails to start once, perform starting again after 3 minutes.	

جدول مشخصات فنی موتور

Item		Specification	
Camshaft	Cam Height (mm)	Intake Cam	37.07 - 37.31
		Exhaust Cam	36.94 - 37.18
	Camshaft Journal Diameter (mm)	Intake Cam	$\phi 24_{-0.053}^{-0.040}$
		Exhaust Cam	$\phi 24_{-0.053}^{-0.040}$
	Camshaft Axial Clearance (mm)	Intake Cam	0.15 - 0.20
		Exhaust Cam	0.15 - 0.20
Cylinder Head	Lower Surface Flatness (mm)		0.04
	Overall Height (mm)		139.4 ± 0.335
	Total Grinding Amount of Cylinder Block and Cylinder Head (mm)		0.20
Valve	Valve Head Margin Thickness (mm)	Intake Valve	0.75 - 1.05
		Exhaust Valve	0.55 - 0.85
	Valve Stem Diameter (mm)	Intake Valve	$\phi 5.98 \pm 0.008$
		Exhaust Valve	$\phi 5.96 \pm 0.008$
	Grommet Width (mm)	Intake Valve	1.154
		Exhaust Valve	1.307
	Clearance Between Valve Stem and Guide (mm)	Intake Valve	0.012 - 0.043
		Exhaust Valve	0.032 - 0.063
	Inclination Angle (°)	Intake Valve	45 - 45.25
		Exhaust Valve	45 - 45.25
Height (mm)	Intake Valve	107.75 - 108.25	
	Exhaust Valve	106.07 - 106.57	
Valve Spring	Free Height (mm)		47.8
	Operating Preload/Operating Height (mm)		229 - 251 N/41

Item		Specification	
Valve Guide	Valve Guide Length (mm)	42 ± 0.25	
	Inner Diameter (mm)	φ6.0 ± 0.015	
	Outer Diameter (mm)	φ11 ^{+0.040} / _{+0.051}	
	Depression Depth (mm)	18.5 ± 0.3	
	Valve Stem Protrusion Amount (mm)	Intake Valve 28.997 Exhaust Valve 29.015	
Piston	Piston Skirt Diameter (mm)	φ76.950 ± 0.009	
Piston Ring	Side Clearance (mm)	First Ring	0.040 - 0.085
		Second Ring	0.040 - 0.075
	End Gap (mm)	First Ring	0.2 - 0.4
		Second Ring	0.4 - 0.6
	Height (mm)	First Ring	1 ^{-0.01} / _{-0.03}
		Second Ring	1.2 ^{-0.050} / _{-0.030}
Oil Ring		1.5 ^{-0.02} / _{-0.13}	
Piston Ring Groove	Height (mm)	First Ring	1.2 ^{+0.055} / _{+0.03}
		Second Ring	1.2 ^{+0.045} / _{+0.025}
		Oil Ring	1.5 ^{+0.03} / _{+0.01}
Piston Pin	Diameter (mm)	17.992 - 17.997	
	Length (mm)	45 ⁰ / _{-0.3}	
	Piston Pin Hole Diameter (mm)	φ18 ^{+0.010} / _{+0.004}	
Crankshaft	Axial Clearance (mm)	0.070 - 0.265	
	Radial Clearance (mm)	0.023 - 0.075	
	Crankshaft Main Journal	Diameter (mm)	49.979 - 50.000
		Coaxially (mm)	0.05
		Cylindricity (mm)	0.007
		Roundness (mm)	0 - 0.008
	Connecting Rod Journal	Diameter (mm)	φ46 ⁰ / _{-0.016}
Parallelism to Main Journal (mm)		0.008	
Cylinder Block	Overall Height (mm)	274.9 ^{+0.1} / ₀	
	Bore Roundness (mm)	0.008	
	Cylindricity (mm)	0.01	
	Upper Surface Flatness (mm)	0.04	
Connecting Rod	Big End Hole Radial Clearance (mm)	0.026 - 0.075	
	Big End Axial Clearance (mm)	0.15 - 0.40	

فشار سوخت

SQR371F	Pressure (kPa)
Fuel Pressure on Fuel Rail - Key II (ON)	350
Fuel Pressure on Fuel Rail - Engine Idling	400
Fuel Pressure on Fuel Rail - Key B (LOCK)	350

ظرفیت مایع خنک کننده

Item	Capacity (L)
Cooling System	7.4

Cooling System Test Pressure

Item	Test Pressure (bar)
Cooling System (Test Pressure)	1.3 ± 0.2

مشخصات سیستم روغن کاری

Condition	Pressure (bar)
Low Idling (700 ± 50 r/min)	0.7
High Idling (2000 r/min)	1.8
High Speed (4000 r/min)	3.0

Engine Type	SQRE4G15B
Oil Capacity (L)	4 ± 0.5
Oil Specifications	Summer: SAE 10W - 40 (SM grade or higher) Winter: SAE 5W - 40 (SM grade or higher)

مشخصات شمع

Spark Plug Specifications

Engine Type	SQRE4G15B
Spark Plug Type	3707AAG
Spark Plug Gap (mm)	0.8 - 0.9

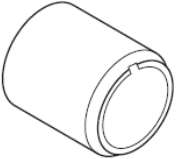
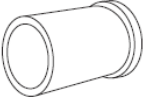
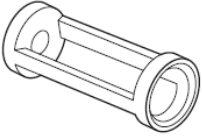
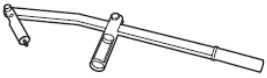
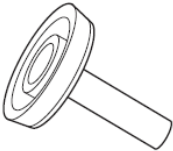
<p>Crankshaft Front Oil Seal Guide Tool</p>	 <p>RCH0000049</p>
<p>Crankshaft Front Oil Seal Installer</p>	 <p>RCH0000067</p>
<p>Valve Spring Compression Adapter</p>	 <p>RCH0000050</p>
<p>Valve Spring Compressor</p>	 <p>RCH0000028</p>
<p>Crankshaft Rear Oil Seal Guide Tool</p>	 <p>RCH0000031</p>

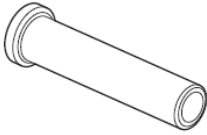
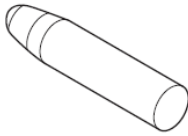
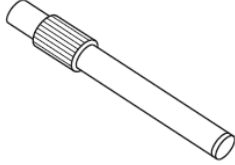
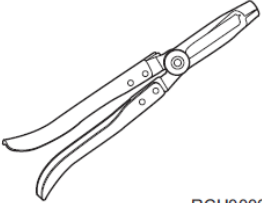
<p>Crankshaft Rear Oil Seal Installer</p>	 <p>RCH0000070</p>
<p>Valve Oil Seal Installer</p>	 <p>RCH0000034</p>
<p>Valve Oil Seal Guide Sleeve</p>	 <p>RCH0000035</p>
<p>Clutch Pressure Plate Installer</p>	 <p>RCH0000018</p>
<p>Valve Oil Seal Remover</p>	 <p>RCH0000037</p>

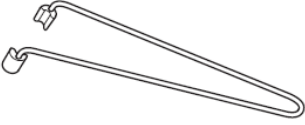
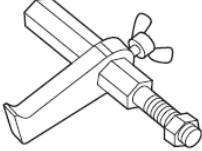
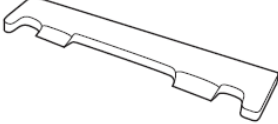
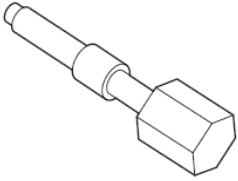
Valve Cotter Installer	 <p>RCH000029</p>
Flywheel Holding Tool	 <p>RCH000040</p>
Camshaft Timing Tool	 <p>RCH000033</p>
Crankshaft Timing Tool	 <p>RCH000027</p>

جهت بررسی ابزار مخصوص ها به لیست SPECIAL TOOLS مراجعه کنید.

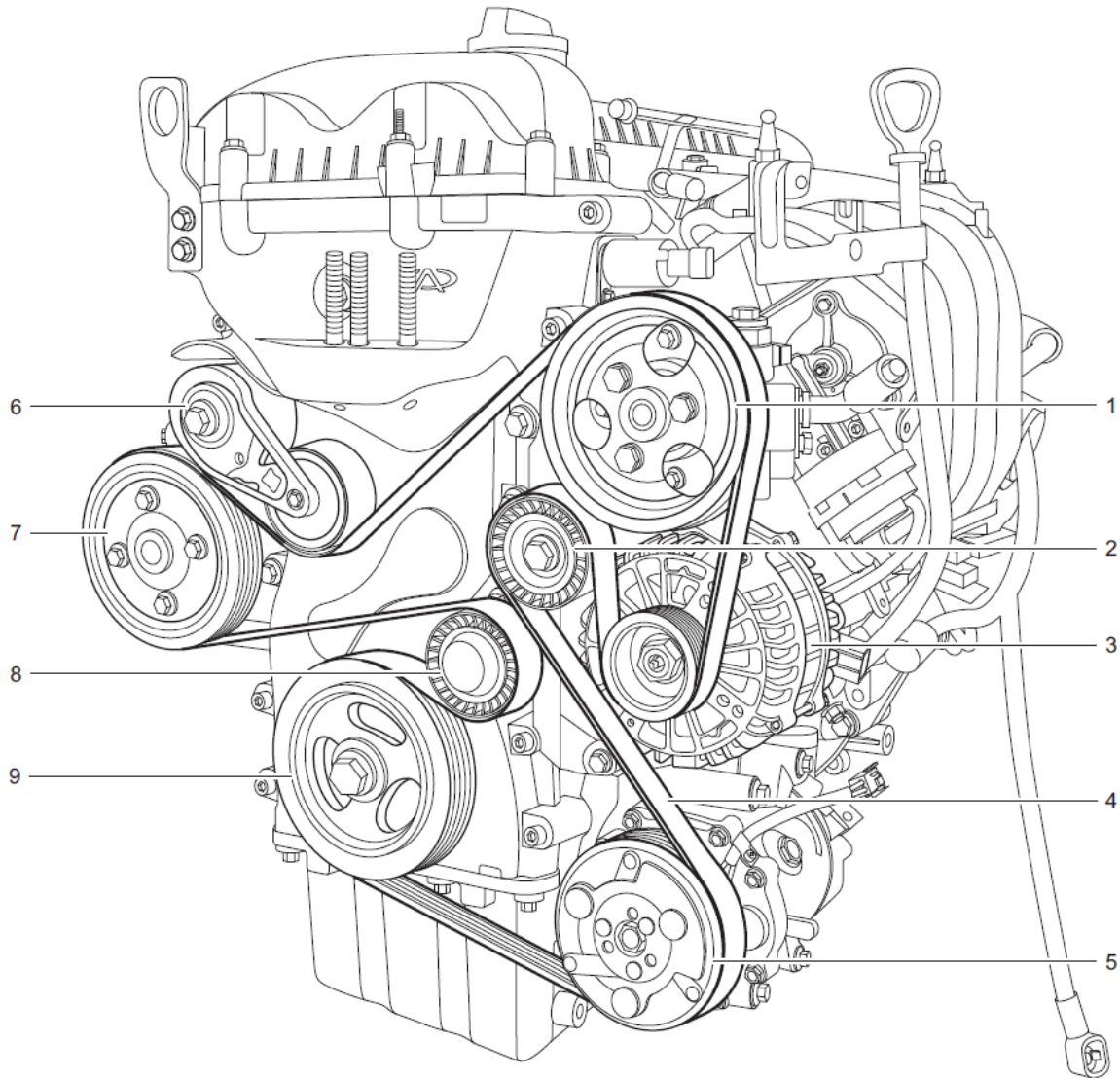

1 - Power Steering Pump Pulley	2 - Upper Idler Pulley
3 - Alternator	4 - Accessory Drive Belt
5 - A/C Compressor Pulley	6 - Belt Tensioner Assembly
7 - Water Pump Pulley	8 - Lower Idler Pulley
9 - Crankshaft Pulley	

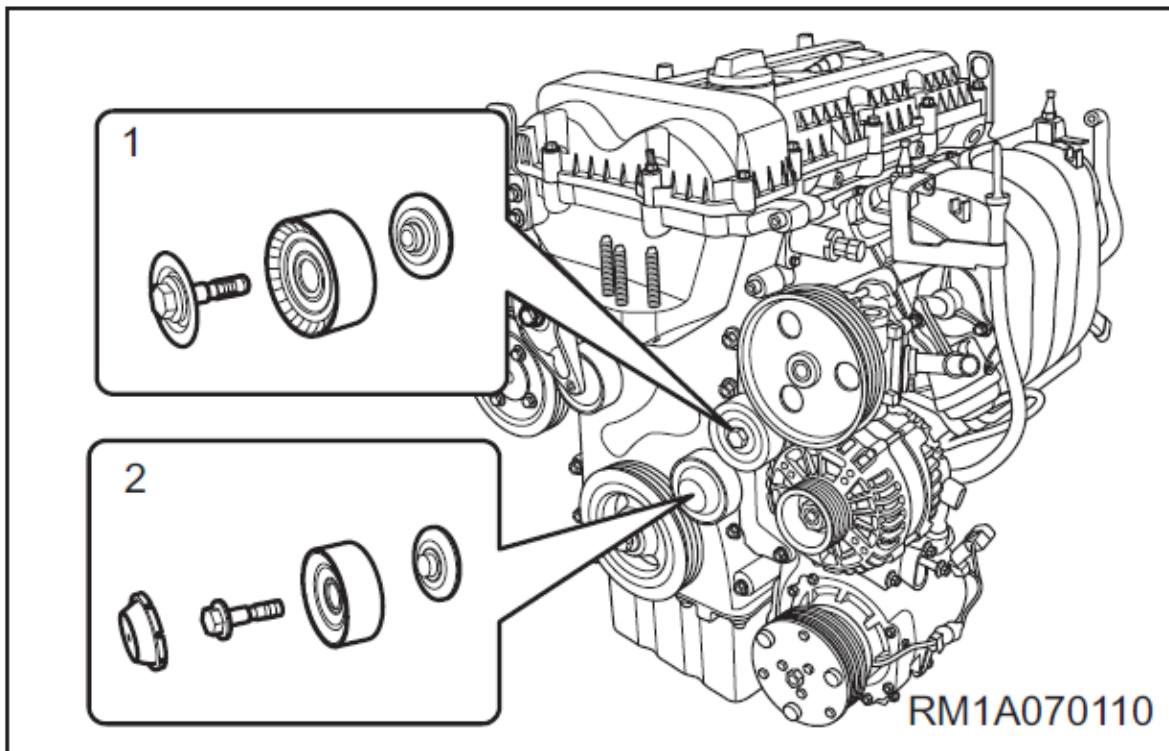
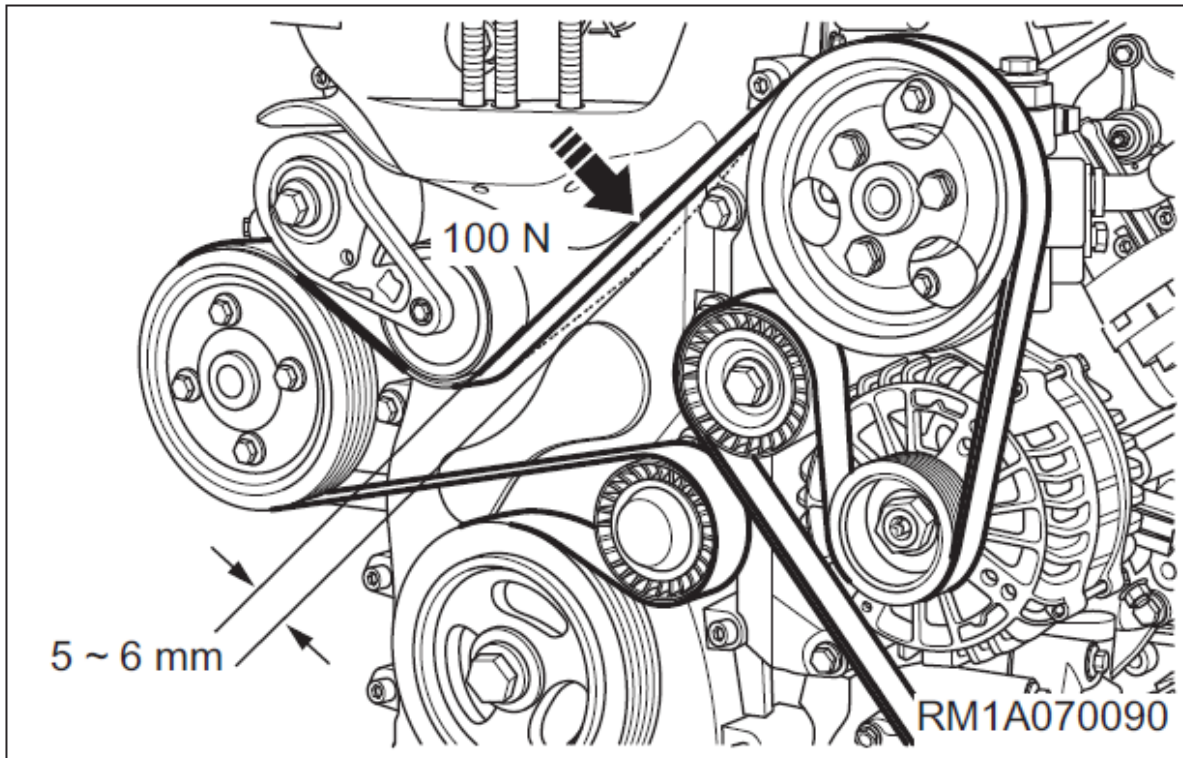

گشتاور پیچ سر میل لنگ

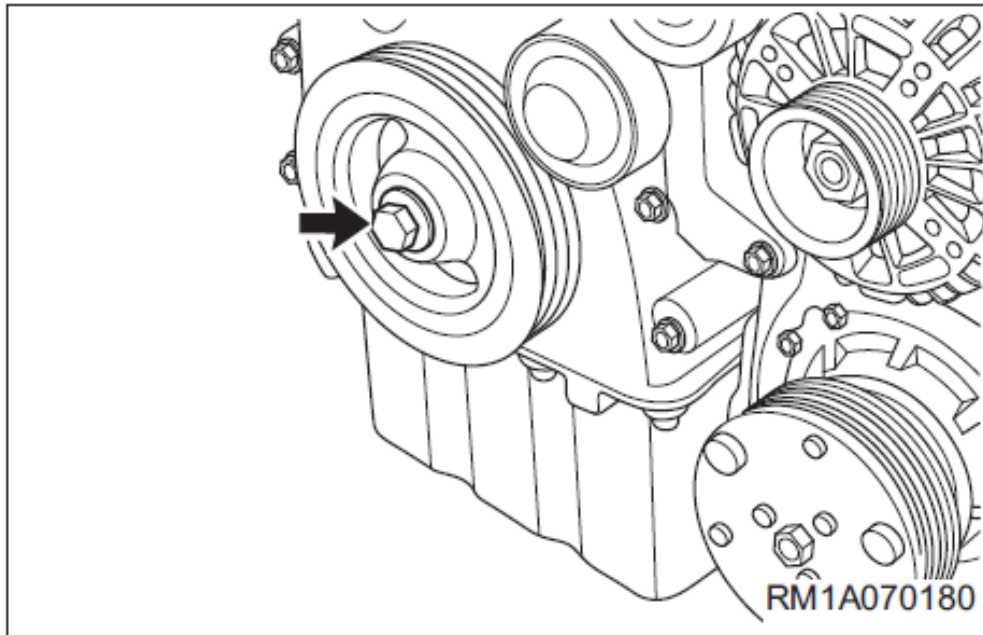

(Tightening torque: 1st step: tighten to 100 ± 10 N·m;
2nd step: retighten by $120^\circ \pm 10^\circ$)

نحوه جازدن کاسه نمد ابتدای میل لنگ

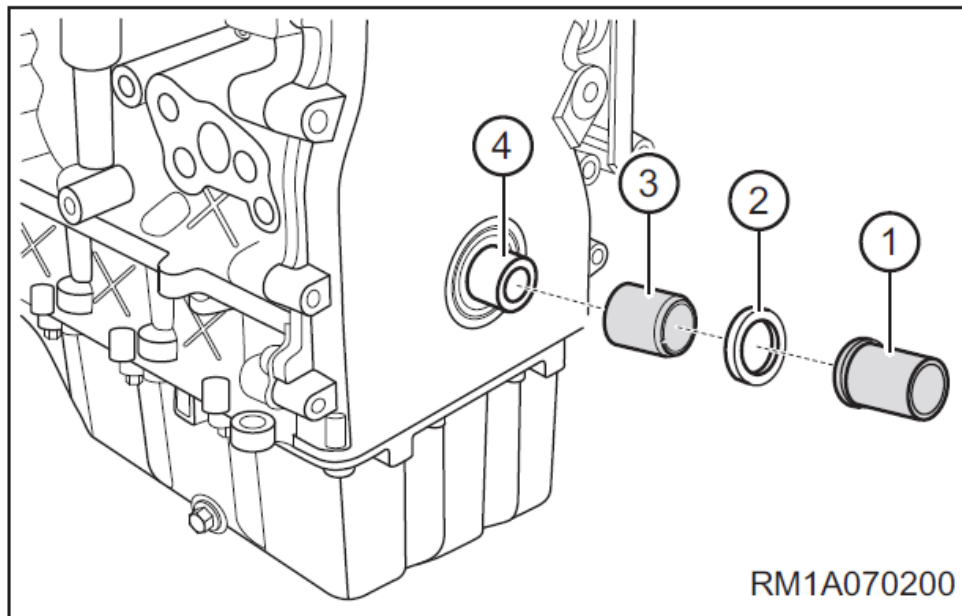

کاربرد ابزار مخصوص قفل کن فلاپویل

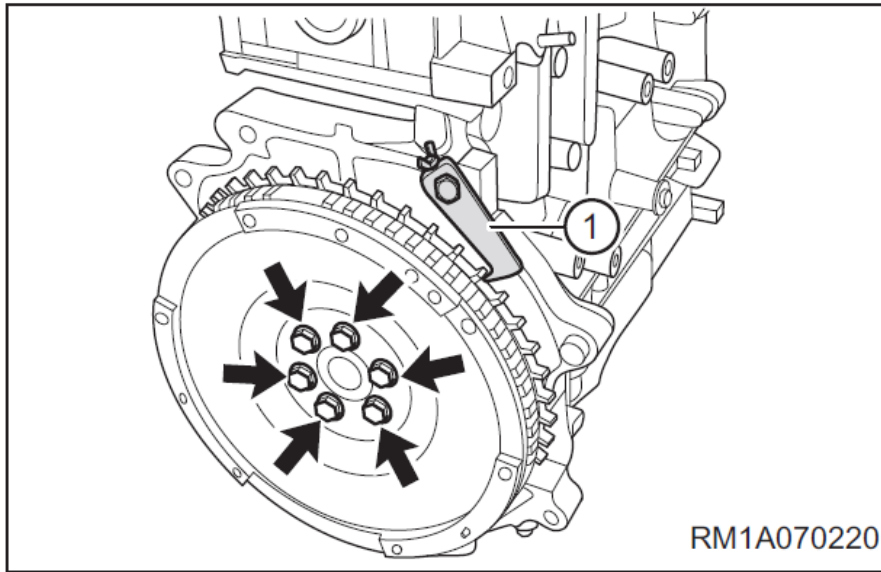

نحوه جازدن کاسه نمد ابتدای میل لنگ

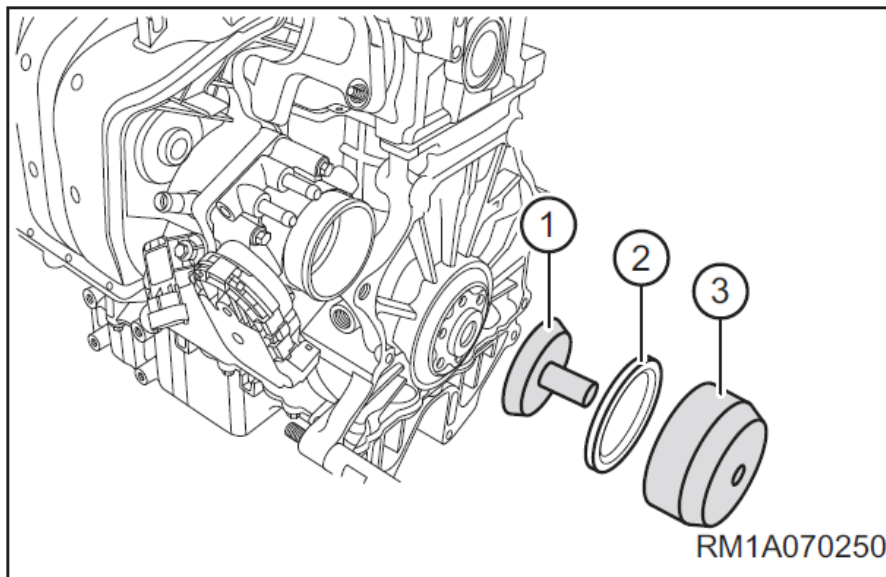

زنجیر تایم و اجزای آن

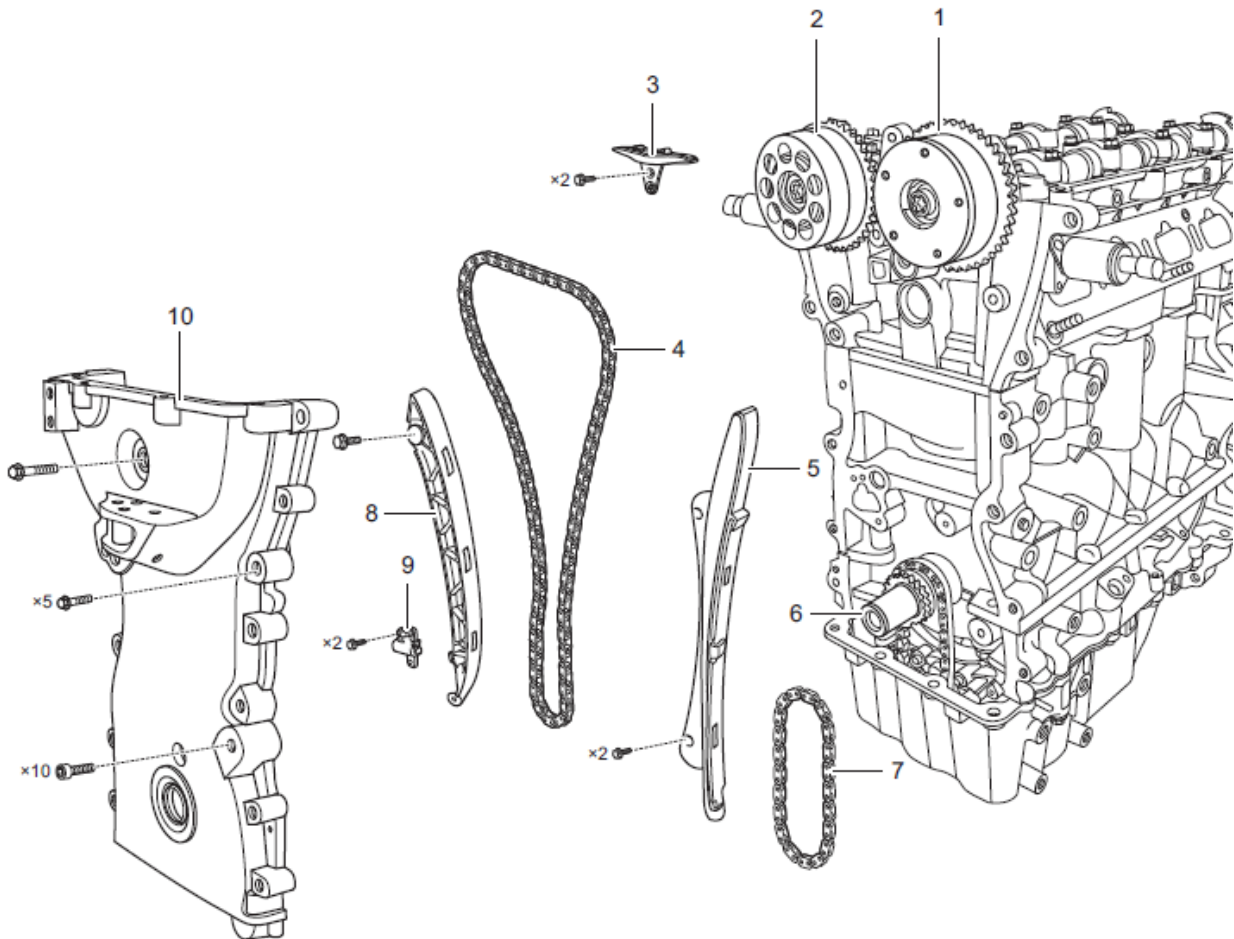

1 - Intake Camshaft Phaser Assembly	2 - Exhaust Camshaft Phaser Assembly
3 - Upper Guide Rail Assembly	4 - Engine Timing Chain
5 - Fixing Guide Rail Assembly	6 - Crankshaft Assembly
7 - Oil Pump Chain	8 - Movable Guide Rail Assembly
9 - Tensioner Assembly	10 - Timing Chain Cover

Position Diagram of Engine Timing Chain

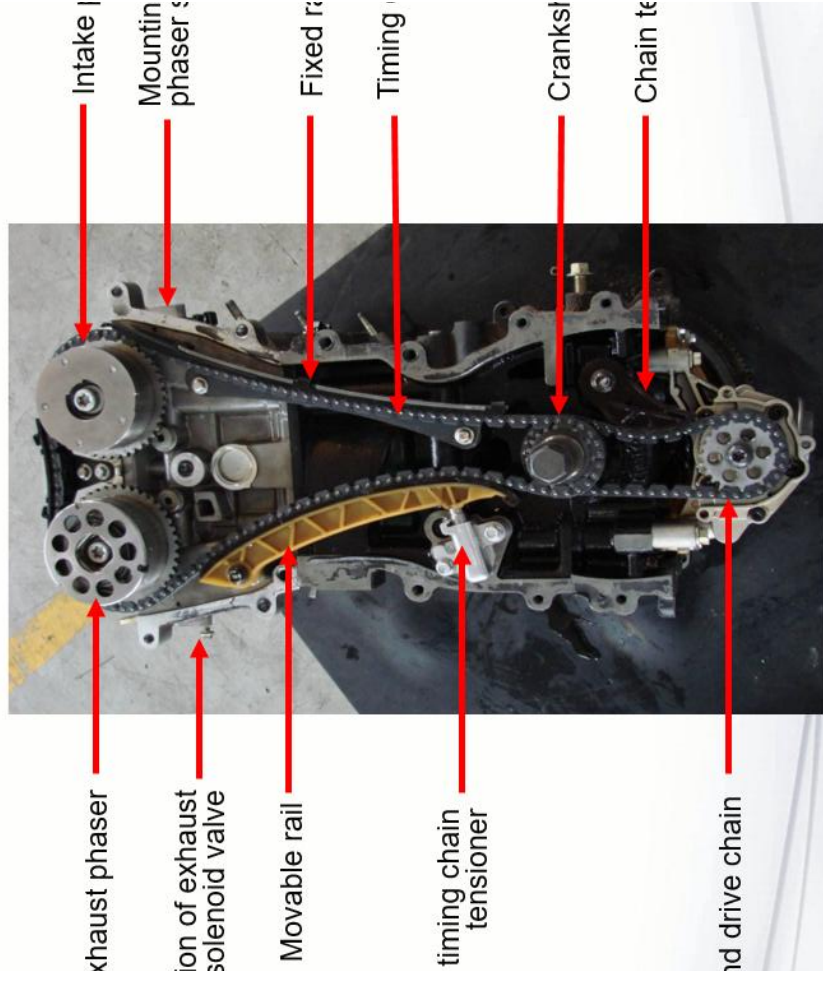

مراحل بازوبست زنجیر تایم و اجزای آن

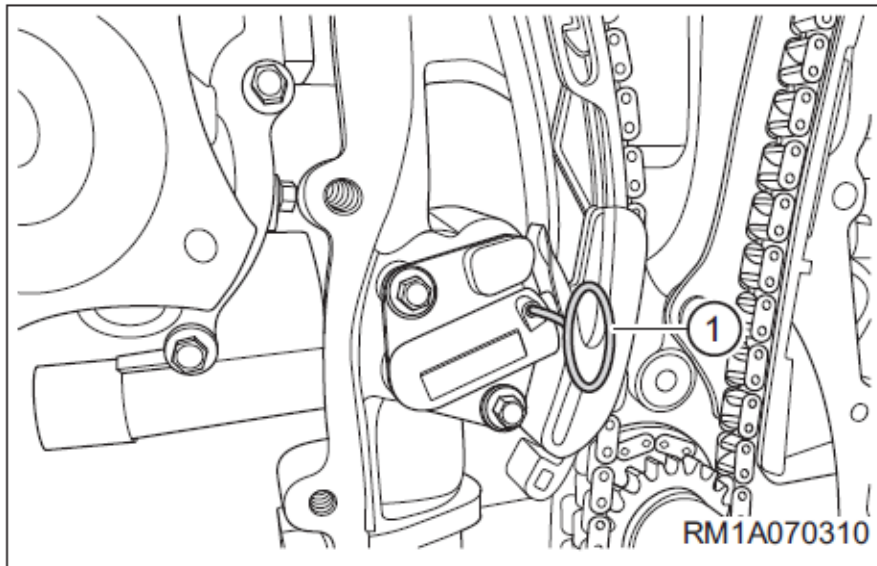

ابتدا زنجیر سفت کن را به عقب فشار دهید و یک پین را درون آن قفل کنید.

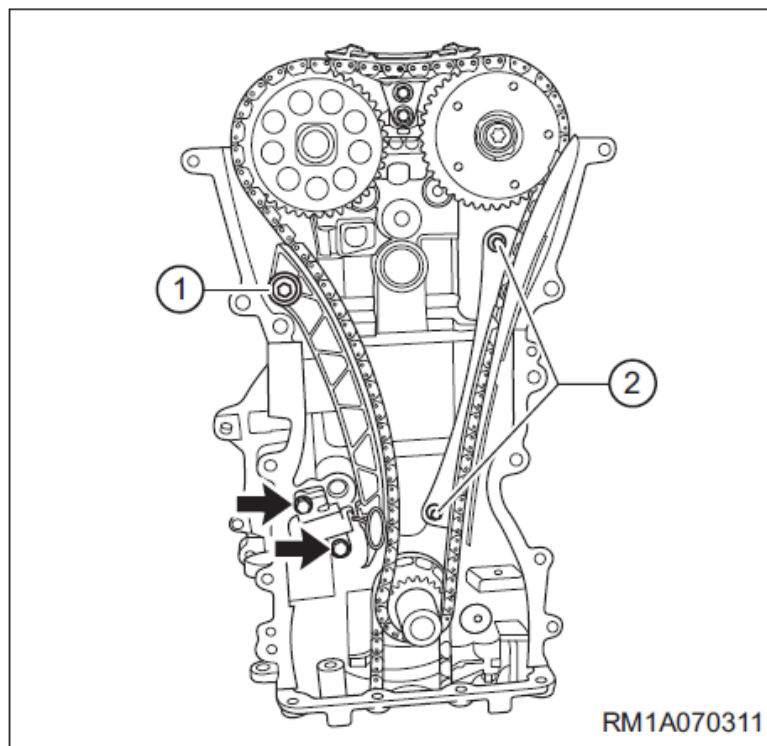

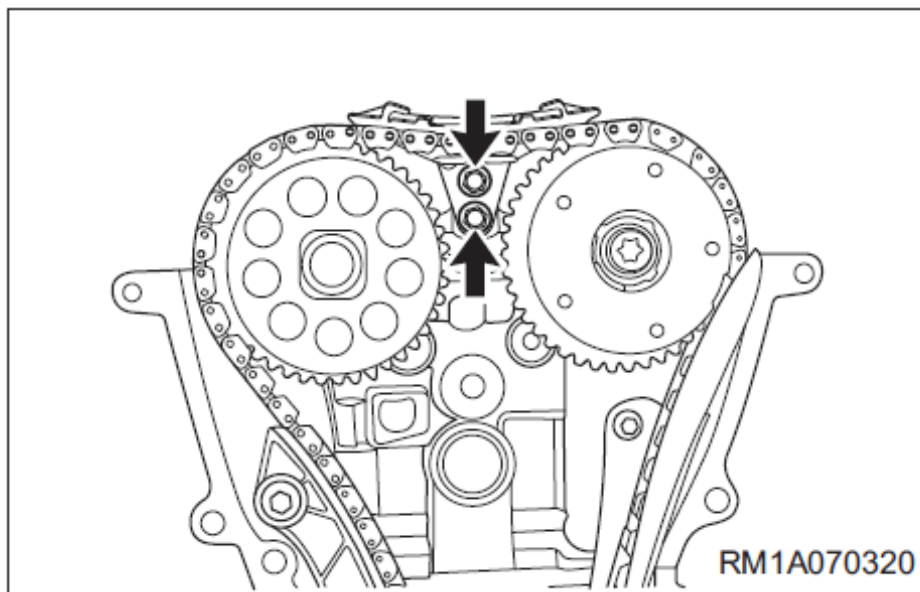

پیچ قاب راهنمای ثابت و متحرک و قاب بالا را باز کنید و زنجیر را آزاد کنید. جلو و پشت زنجیر را علامت بزنید.

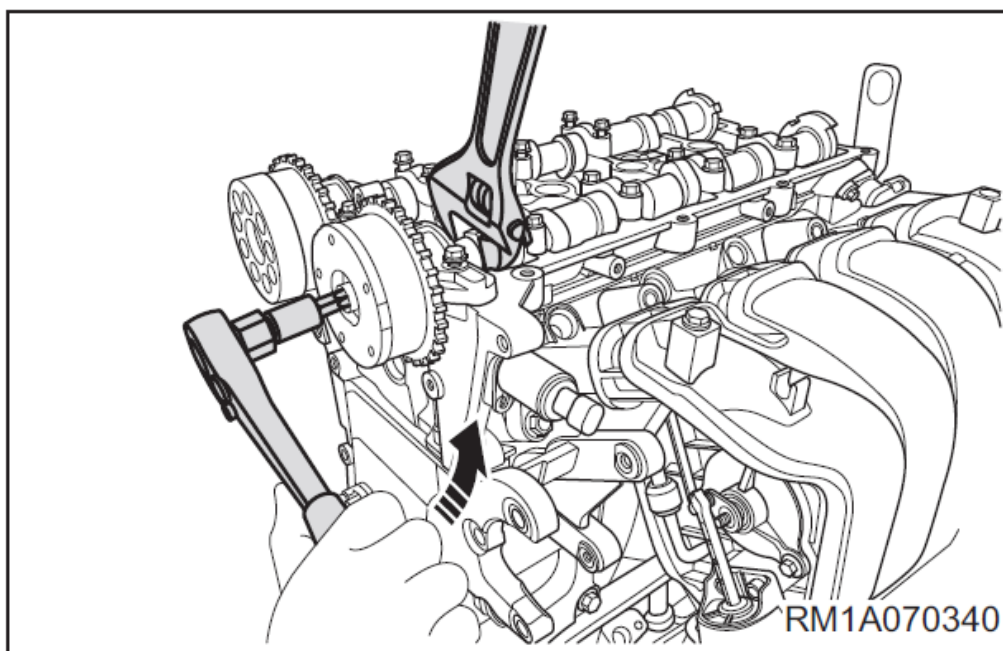

چرخنده میل سوپاپ هوا و دود را باز کنید.

گشتاور باز و بست پیچ چرخنده میل سوپاپ 105 N.m است.

- زنجیر تایم در صورت نداشتن سایش مشخص و یا ترک قابل استفاده مجدد است.
- قاب راهنمای ثابت و متحرک را کنترل نمایید. در صورت داشتن سایش، آنها را تعویض نمایید.

نحوه تایم کردن موتور

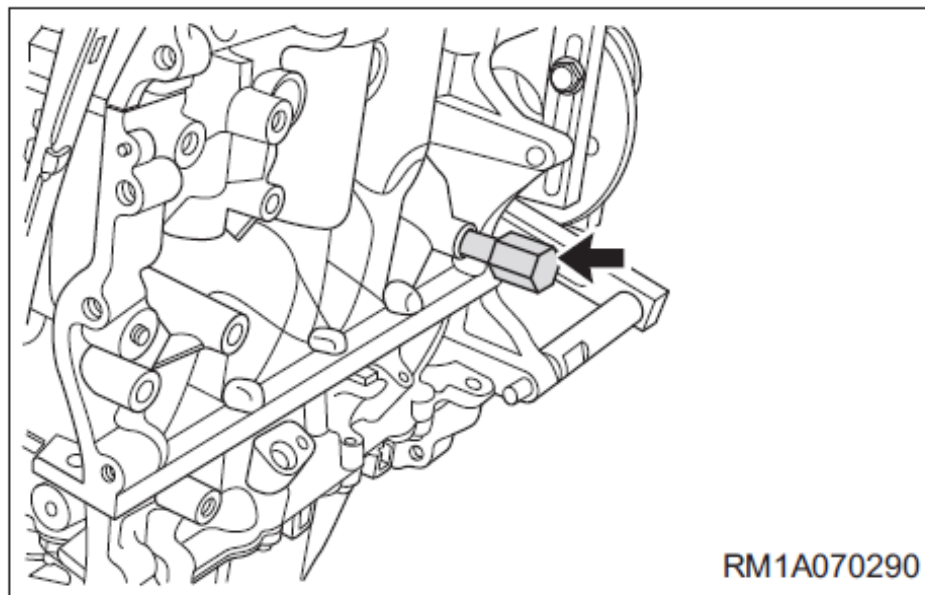
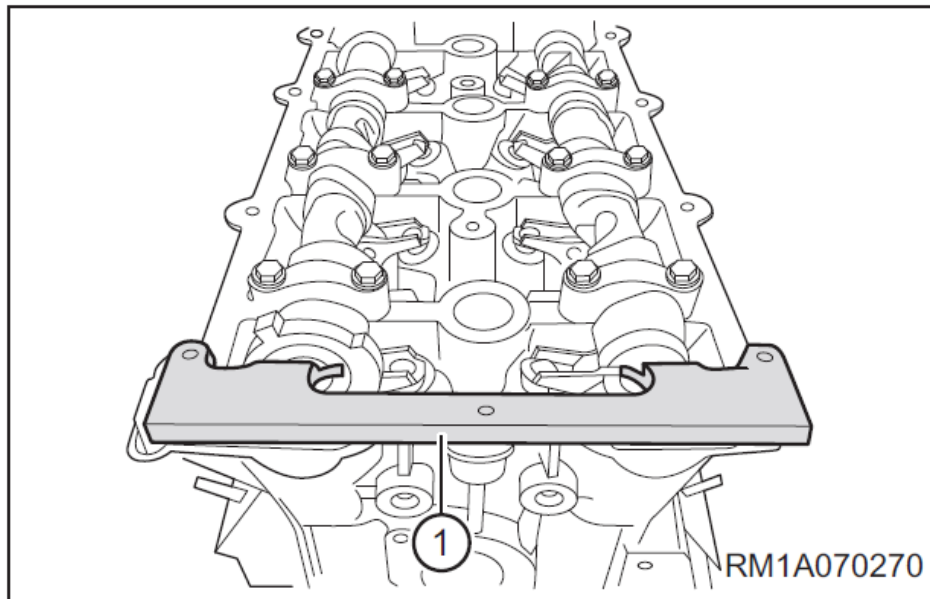

روش تایم کردن موتور را مطابق توضیحات داده شده به صورت کامل بنویسید.

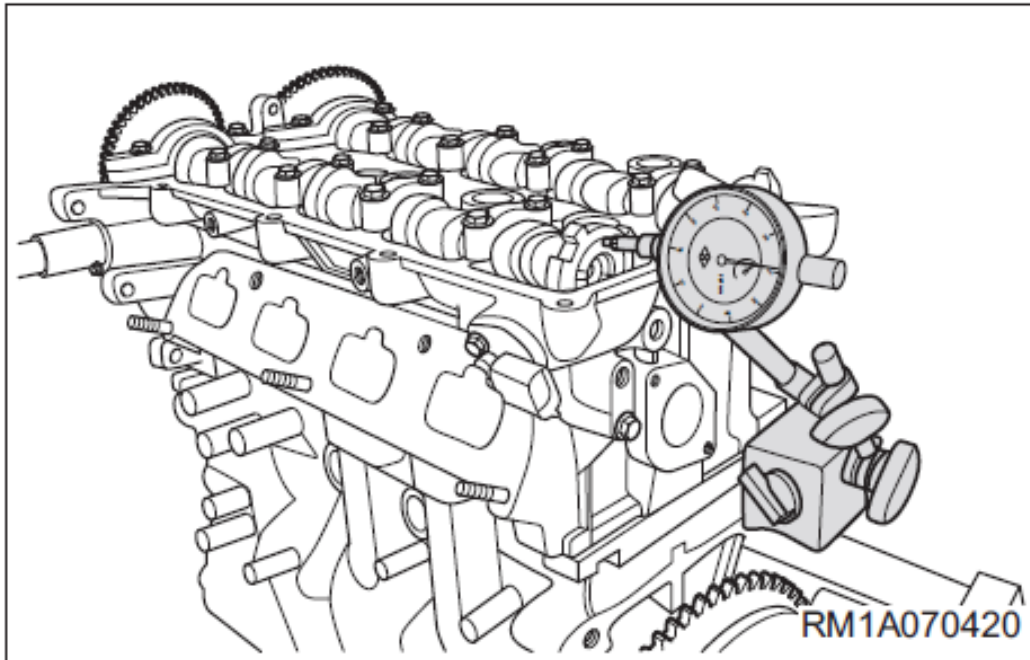

Measurement Item	Specification (mm)
Intake Camshaft Axial Clearance	0.15 - 0.20
Exhaust Camshaft Axial Clearance	0.15 - 0.20

• بستن پيچ هاى كپه ميل سوپاپ (گشتاور 10 N.m)

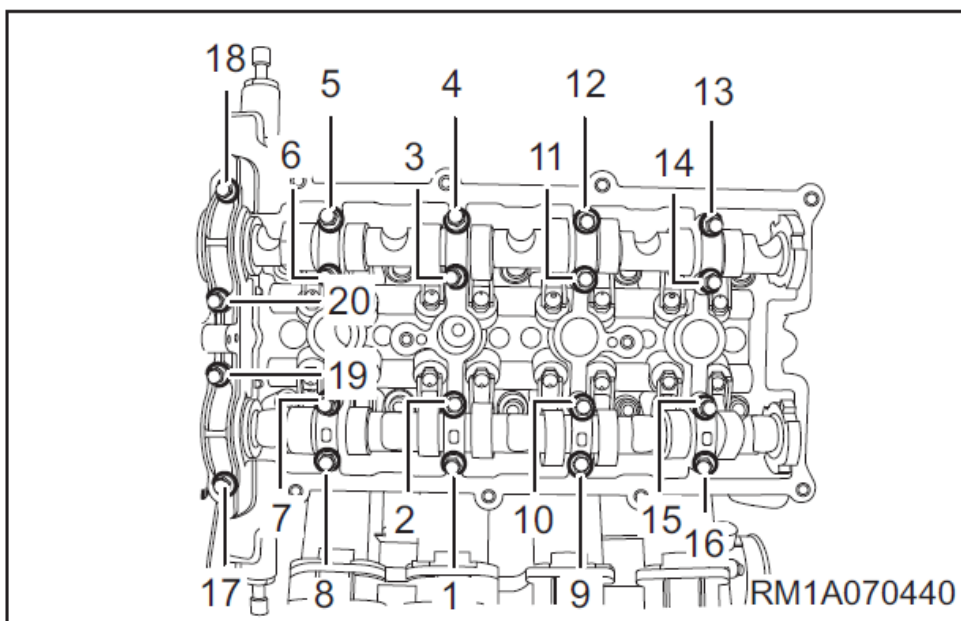

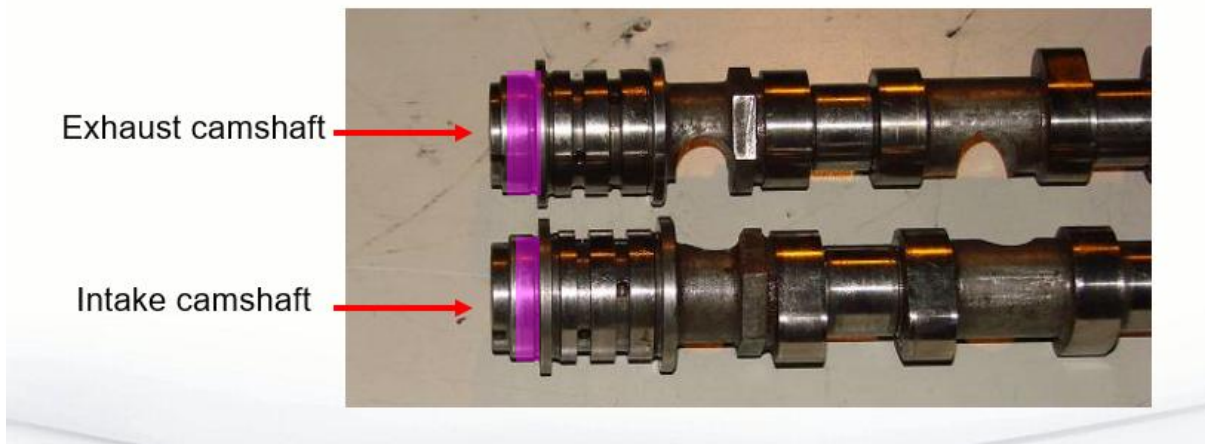
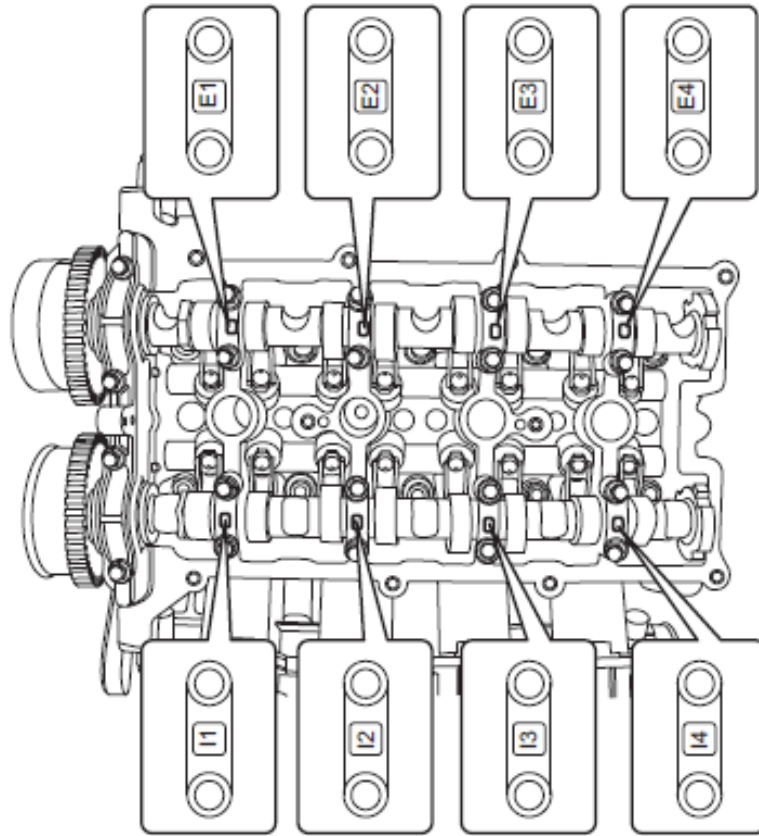

نحوه روغن کاری جداره داخلی سیلندر

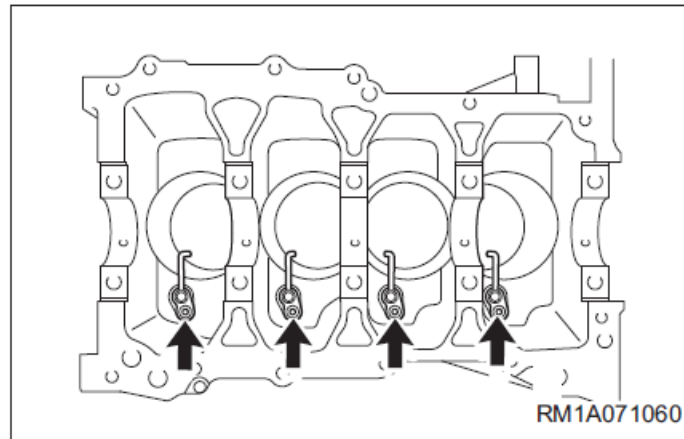

تست سایش میل لنگ

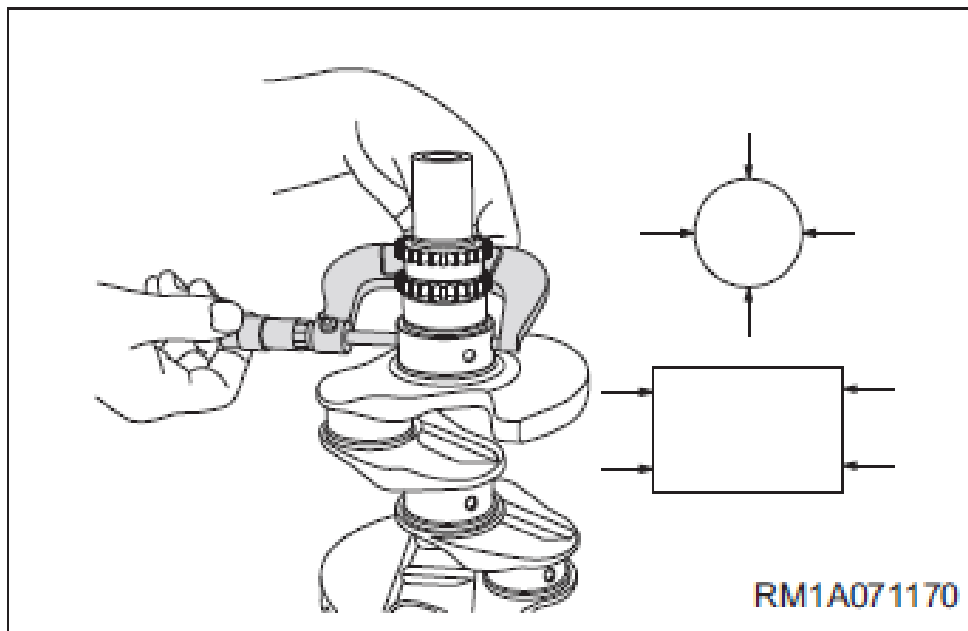

Measurement Item	Specification (mm)
Crankshaft Main Journal Diameter	49.979 - 50.000

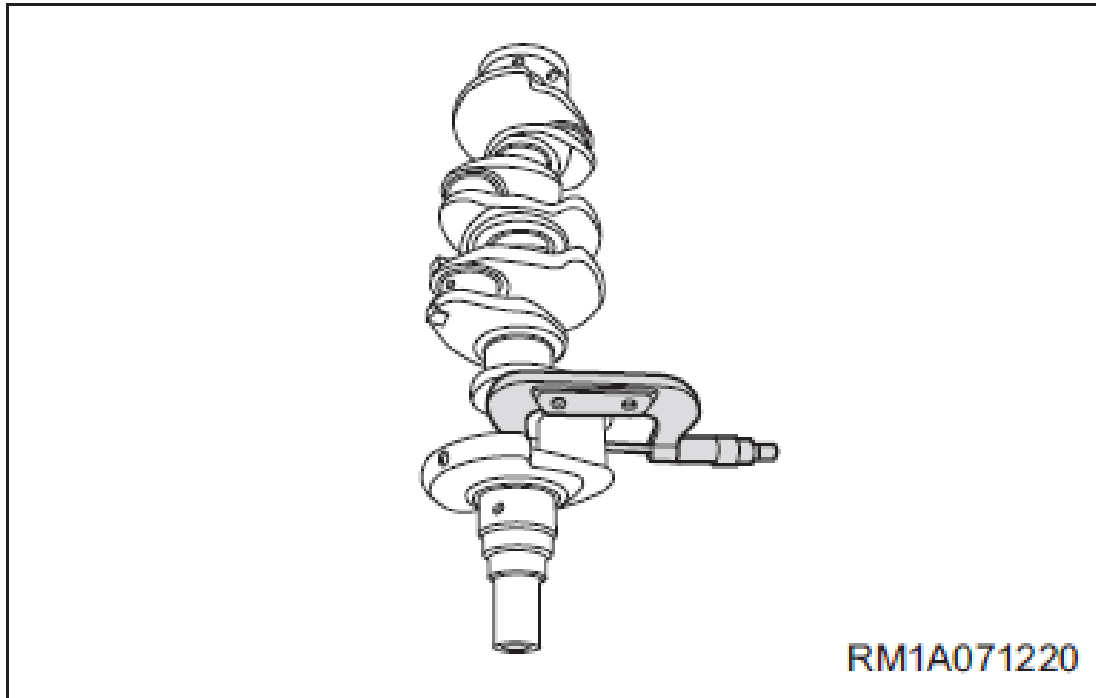

Measurement Item	Specification (mm)
Crankshaft Connecting Rod Journal Diameter	$\phi 47.9^{0}_{-0.016}$

تست لقی شعاعی شاتون

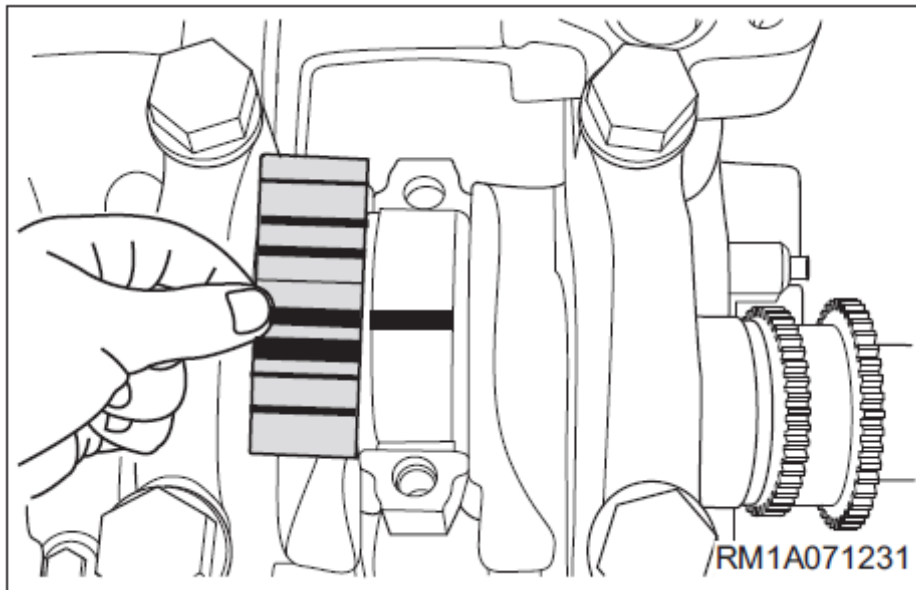
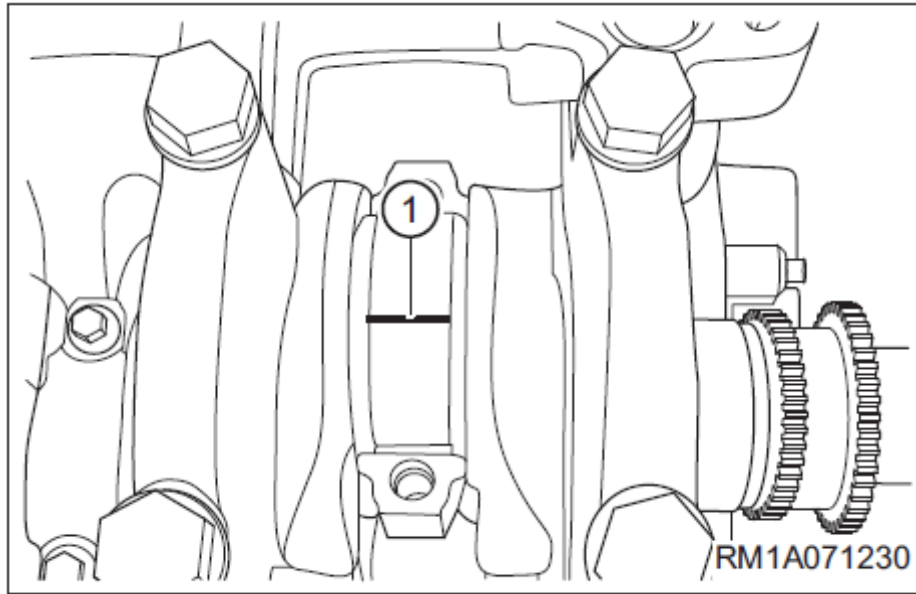

مقادیر مجاز

Measurement Item	Specification (mm)
Connecting Rod Bearing Shell Radial Clearance	0.026 - 0.075

تست لقی طولی شاتون

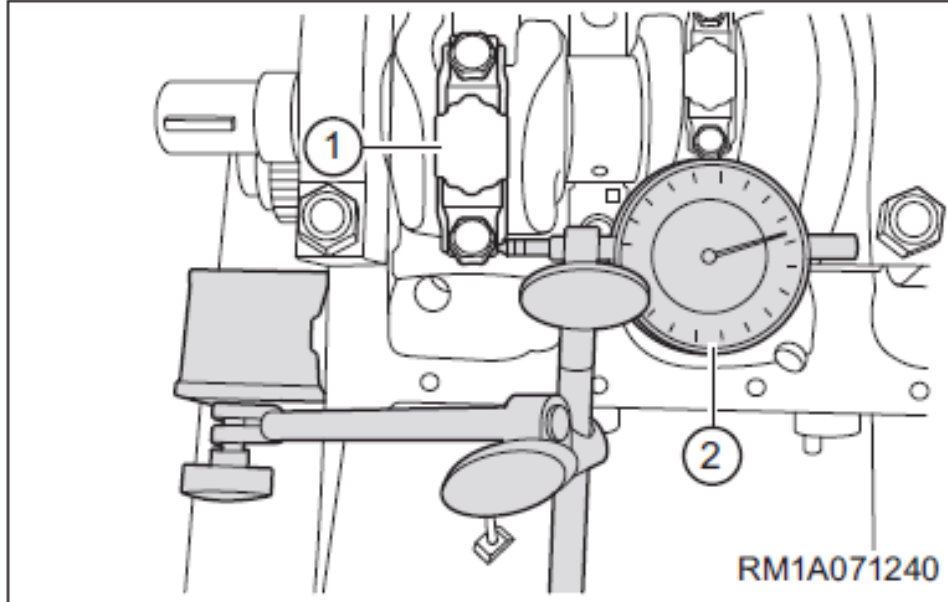

Measurement Item	Specification (mm)
Connecting Rod Big End Axial Clearance	0.15 - 0.40

تست لقی طولی میل لنگ

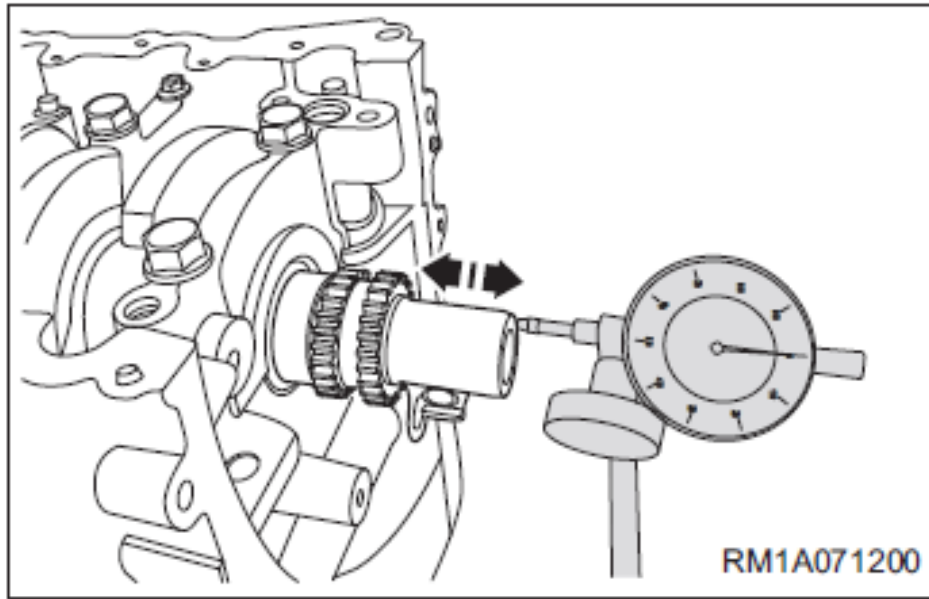

Measurement Item	Specification (mm)
Crankshaft Axial Clearance	0.070 - 0.265

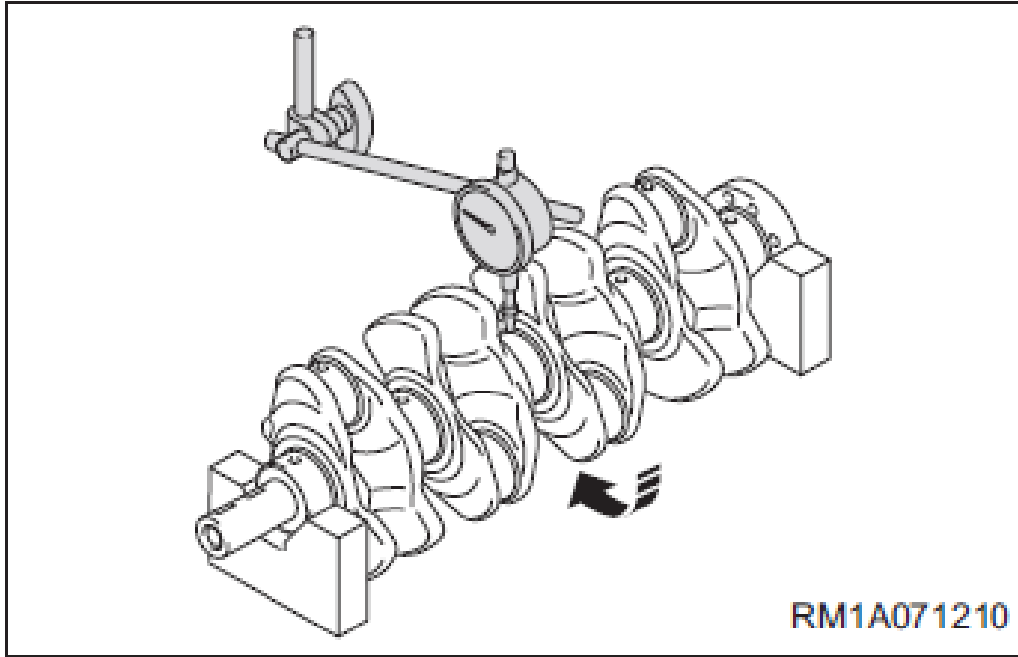

Measurement Item	Specification (mm)
Coaxiality of Crankshaft	0.04

تست لقی شعاعی ثابت

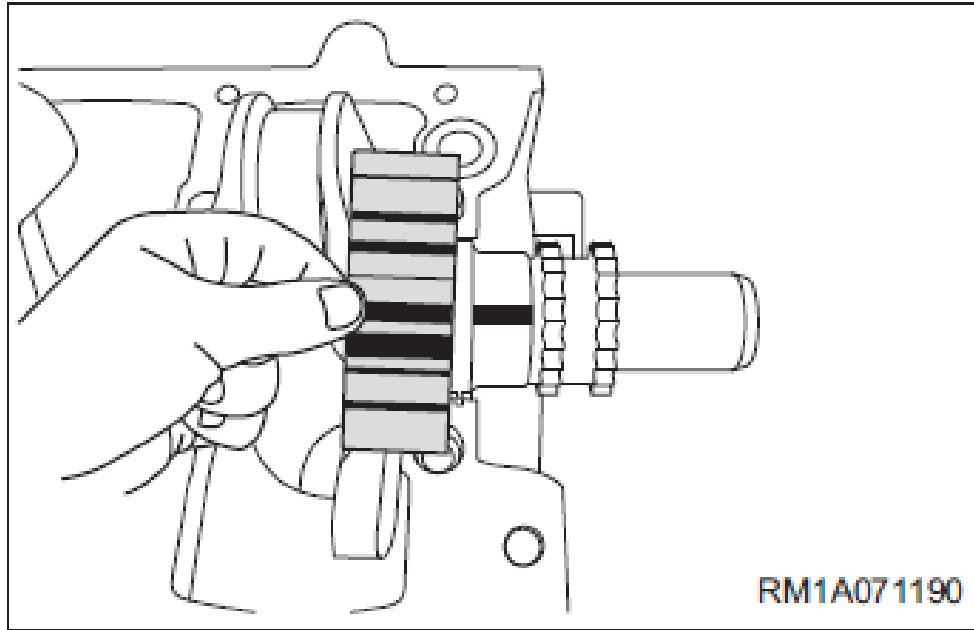

Measurement Item	Specification (mm)
Crankshaft Radial Clearance	0.023 - 0.075

ابزار مخصوص رینگ درآر

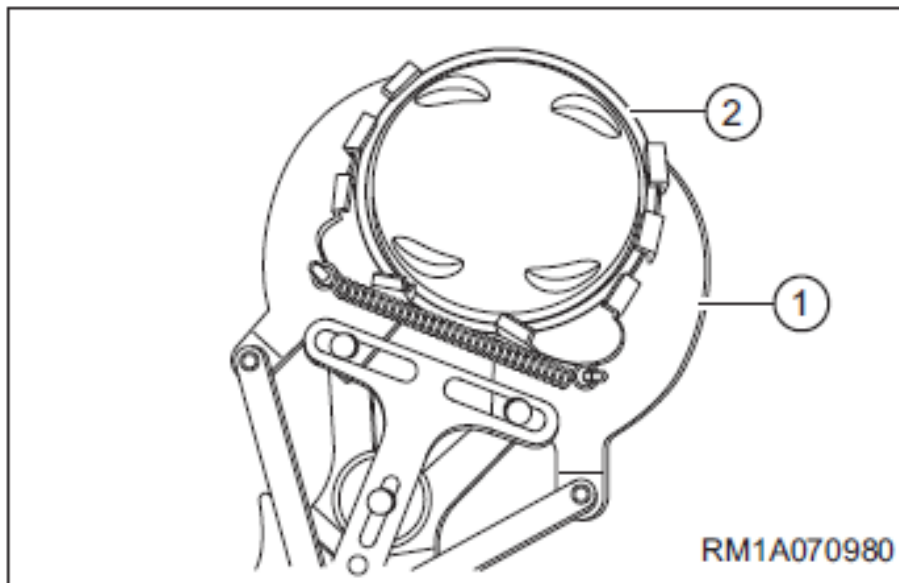

موقعیت دهانه رینگ ها در پیستون:

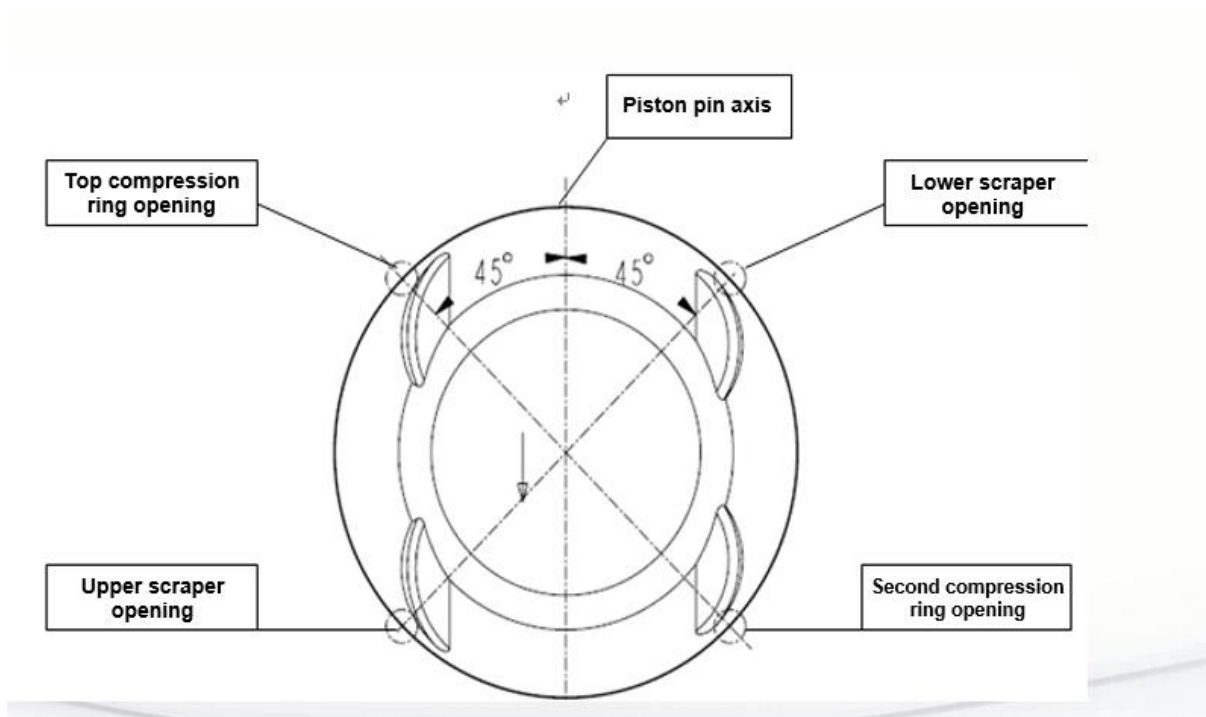

شرایط تنظیم دهانه رینگ ها را بنویسید

اندازه گیری قطر پیستون:

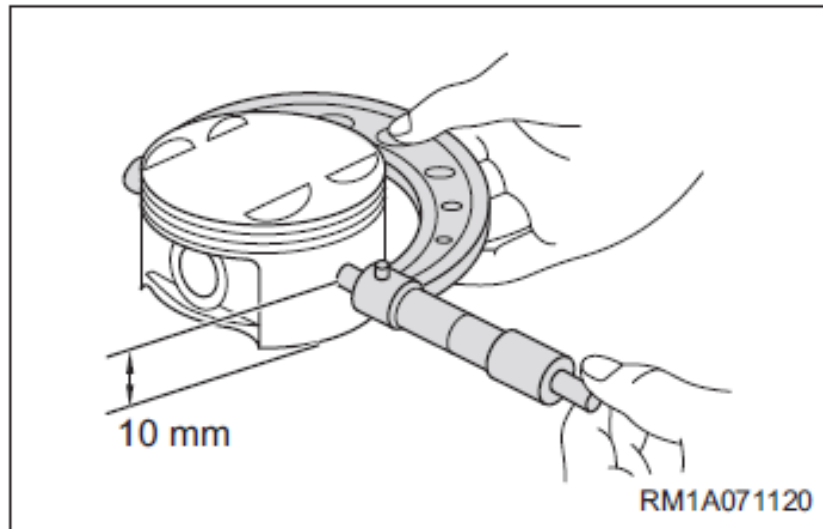

مقدار استاندارد را از جداول یافته و در این قسمت یادداشت نموده و با مقدار واقعی که اندازه گیری نموده اید مطابقت دهید.



SQRE4G15B

اندازه گیری لقی رینگ در پیستون

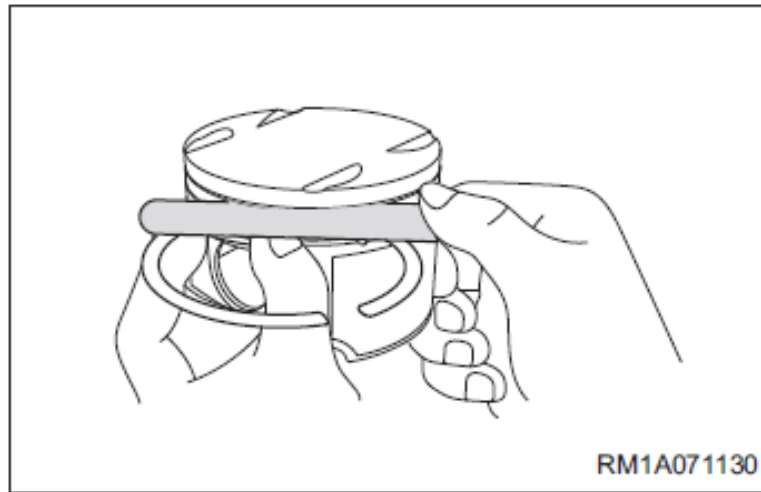

مقادیر مجاز:

Measurement Item		Specification (mm)
Piston Ring Side Clearance	First ring	0.040 - 0.085
	Second ring	0.040 - 0.075

اندازه گیری دهانه رینگ درون سیلندر

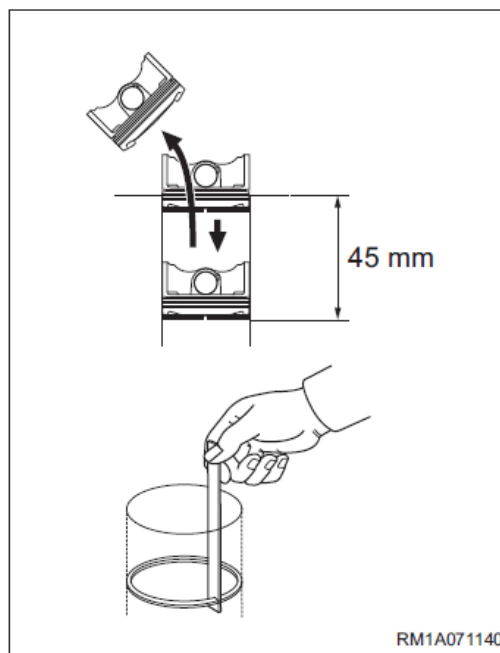

مقادیر مجاز:

Measurement Item		Specification (mm)
Piston Ring End Gap	First ring	0.2 - 0.4
	Second Ring	0.4 - 0.6

شرایط اندازه گیری و نحوه انجام آن:

ابزار اندازه گیری تاب سیلندر:

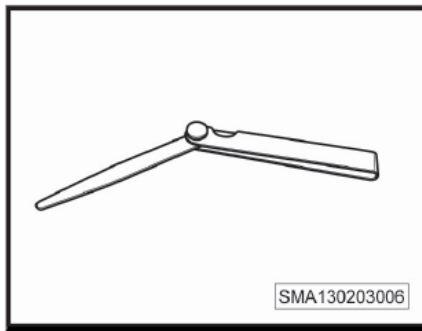

Clearance gauge

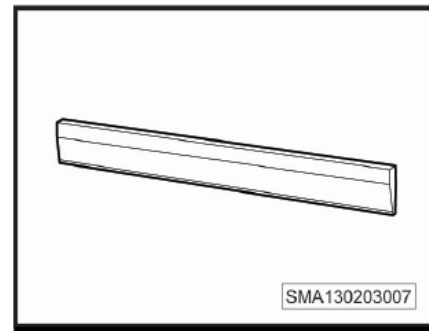

Precision ruler

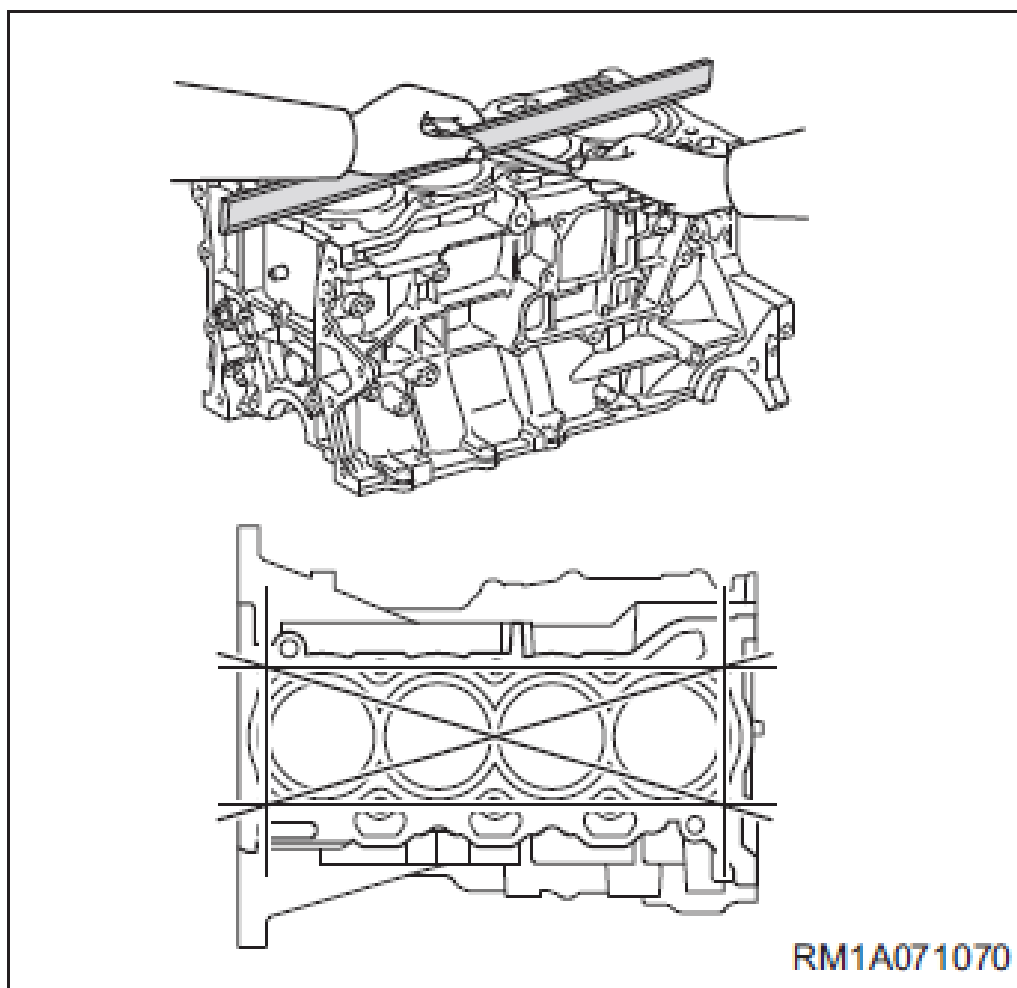

نحوه اندازه گیری و مقادیر مجاز را بنویسید.

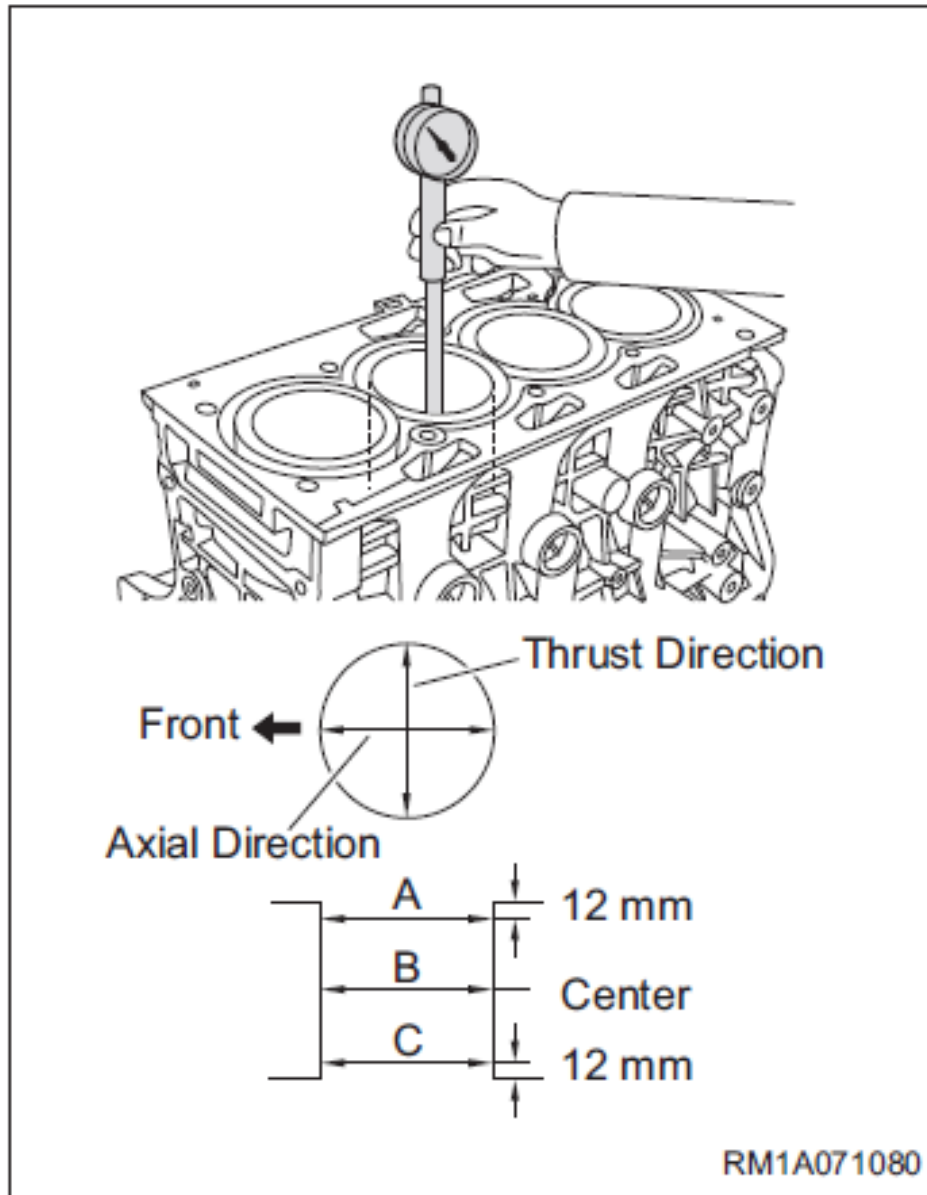

اندازه گیری قطر ساق سوپاپ

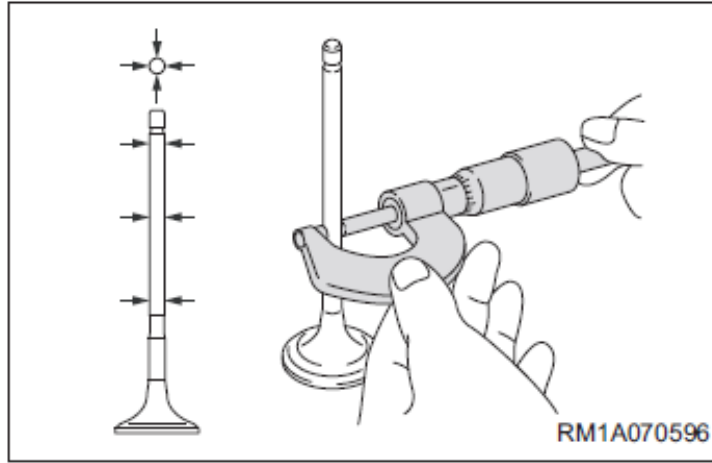

اندازه گیری طول فنر:

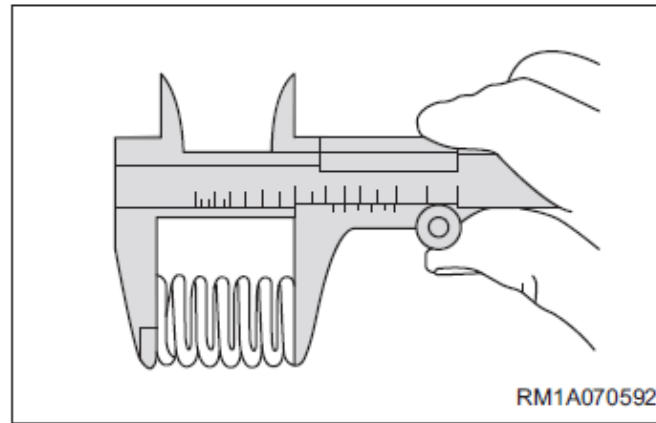

Measurement Item	Specification (mm)
Valve Spring Free Length	47.80
Valve Spring Length Under Operation Pre-pressure	41

مشخصات فنی سرسیلندر

کنترل تاب سرسیلندر:

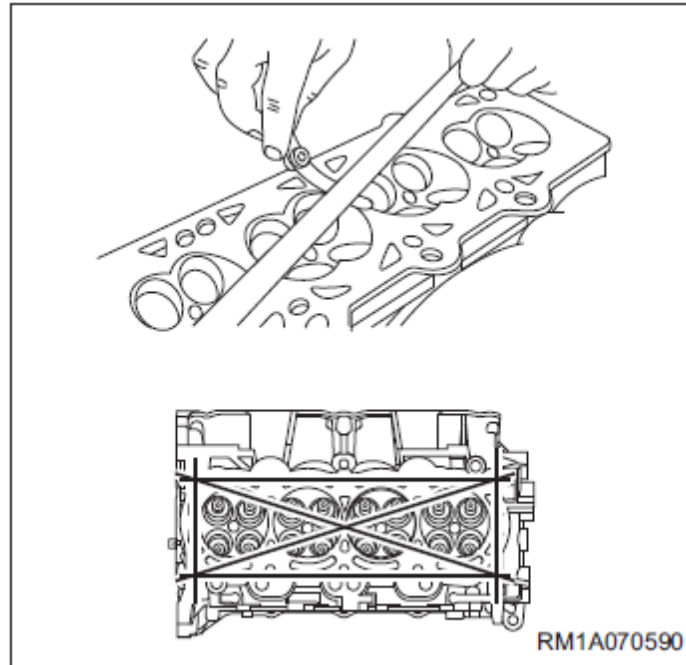

تاب مجاز سرسیلندر: 0.04 mm

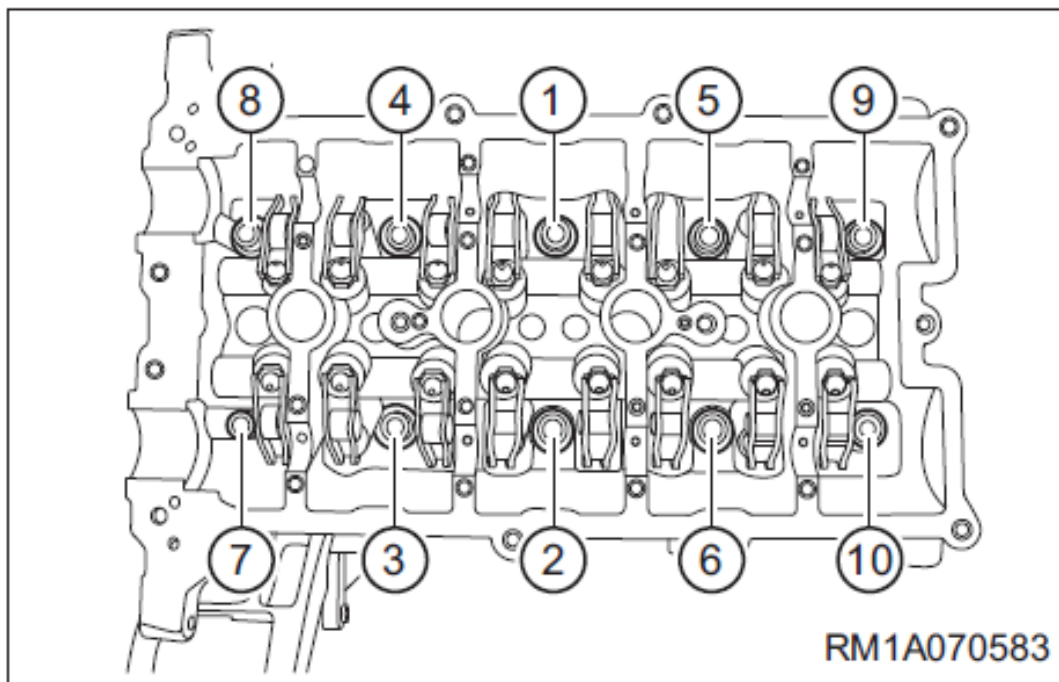

گشتاور بستن پیچ های سرسیلندر:

- 1st step: Tighten bolts to 40 ± 5 N·m in sequence from (1) to (10) shown in illustration.
- 2nd step: Rotate bolts clockwise by $90^\circ \pm 5^\circ$ in tightening sequence.
- 3rd step: Rotate bolts clockwise by $90^\circ \pm 5^\circ$ in tightening sequence.

رنگ بندی یاتاقان

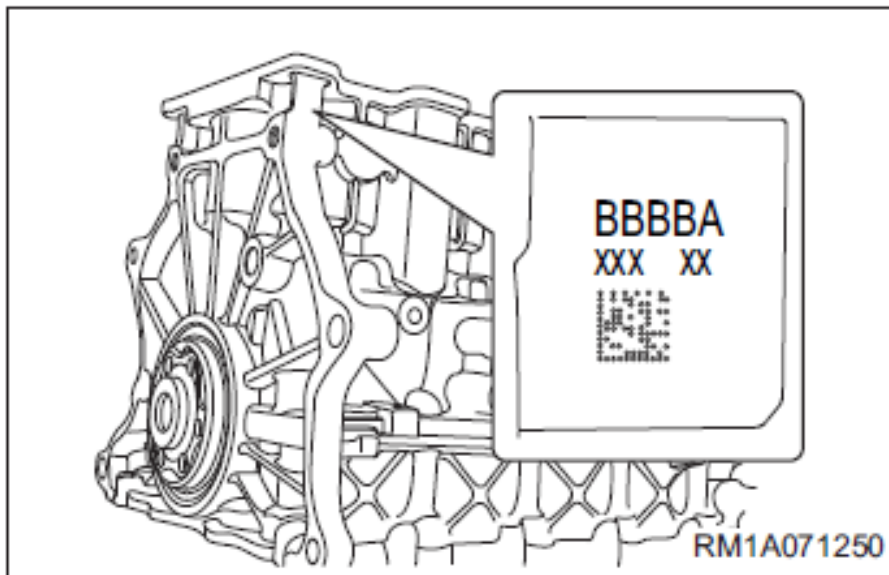

Name	Color	Cylinder Block Mark
Main Bearing Upper Shell	Red	A
	Blue	B

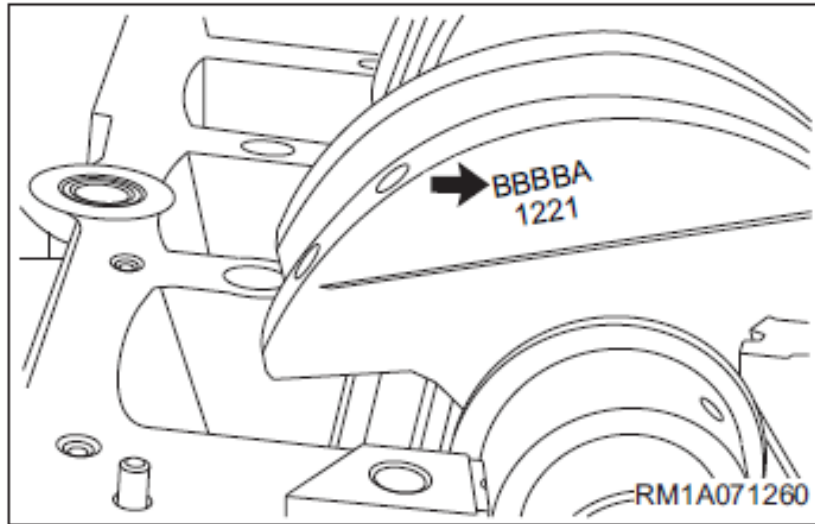

Name	Color	Cylinder Block Mark
Main Bearing Lower Shell	Red	A
	Blue	B

ياتاقان متحرك

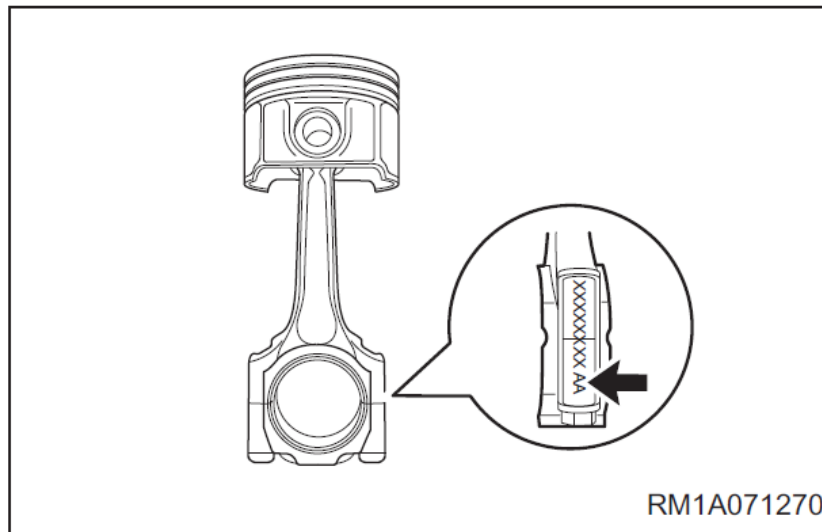

Name	Color	Connecting Rod Mark
Connecting Rod Bearing Upper Shell	Red	A
	Blue	B

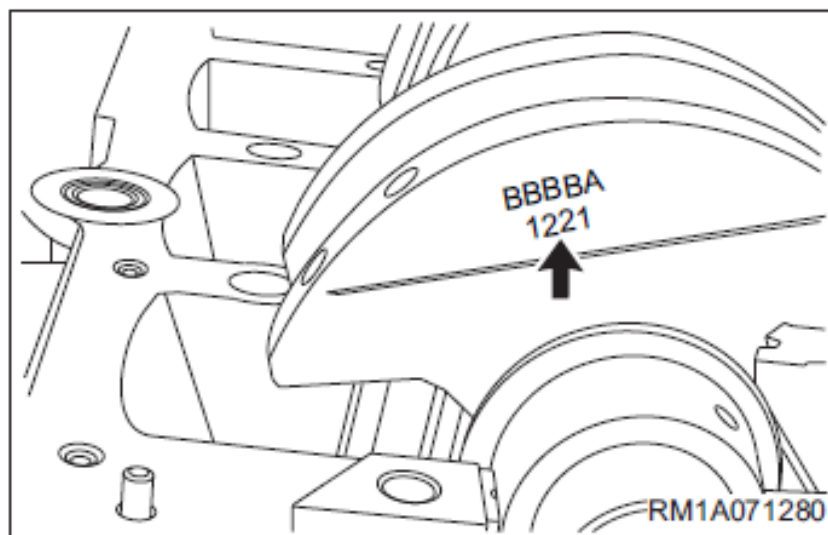

Name	Color	Connecting Rod Mark
Connecting Rod Bearing Lower Shell	Red	1
	Blue	2

بستن پیچ های کپه ثابت میل لنگ

Crankshaft Main Bearing Cap Fixing Bolt	1st step: 45 ± 5 2nd step: $180^\circ \pm 10^\circ$
---	--

گشتاور بستن پیچ های شاتون:

Connecting Rod Bearing Cap Fixing Bolt	1st step: $15 + 3$ 2nd step: $60^\circ \pm 2^\circ$
--	--

شماتیک مدار خنک کاری

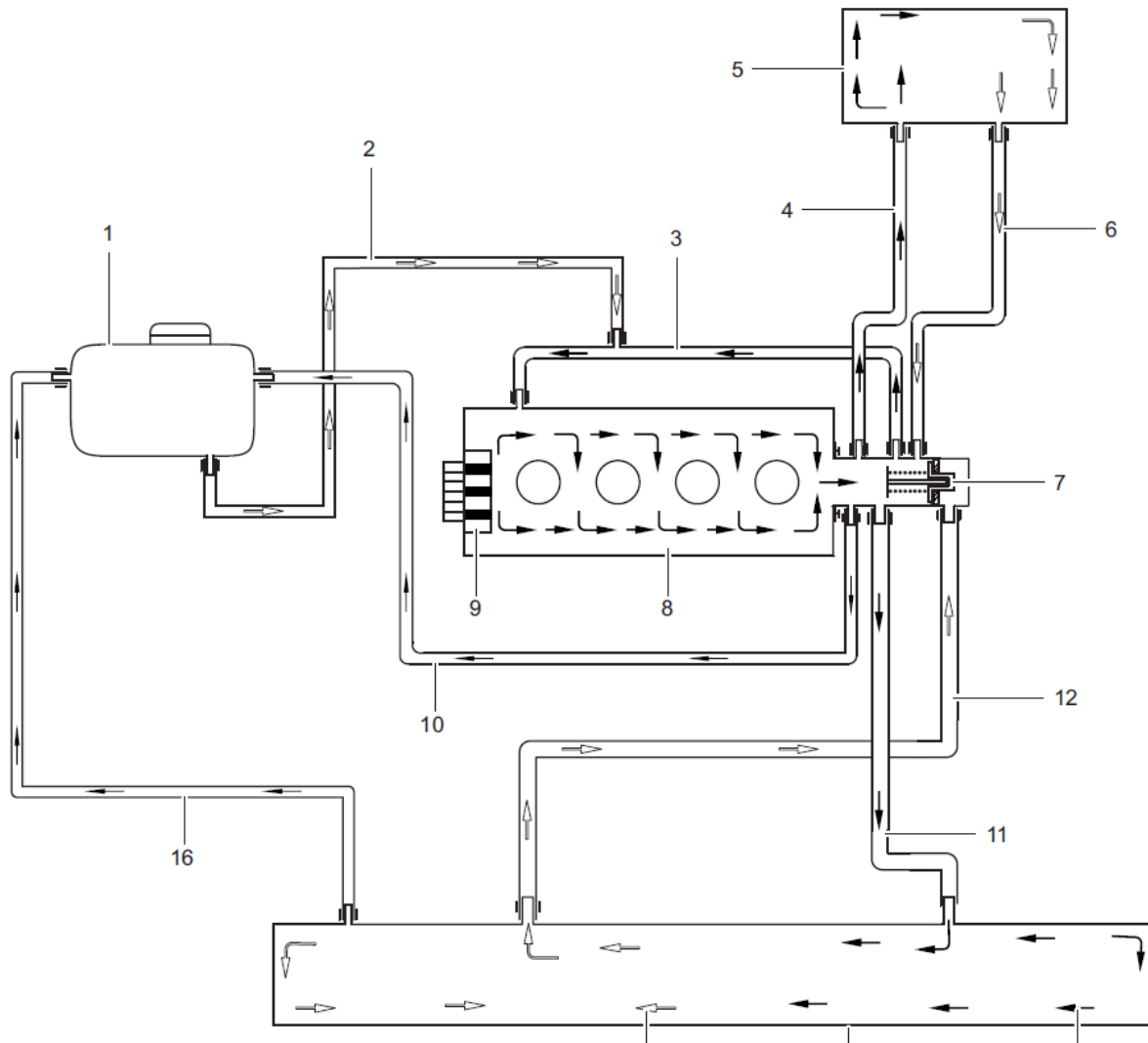

1 - Expansion Tank	2 - Expansion Tank Outlet Pipe
3 - Small Circulation Water Pipe	4 - Heater Inlet Pipe
5 - Heater Core	6 - Heater Outlet Pipe
7 - Thermostat Assembly	8 - Cylinder Block
9 - Water Pump	10 - Engine Discharge Pipe
11 - Engine Outlet Pipe	12 - Engine Inlet Pipe
13 - Black Solid Arrow (Indicates High Temperature Coolant)	14 - Radiator
15 - Hollow Arrow (Indicates Low Temperature Coolant)	16 - Radiator Discharge Hose

- When coolant temperature is higher than 96°C, cooling fan starts to operate at low speed.
- When coolant temperature is higher than 102°C, cooling fan starts to operate at high speed.
- When coolant temperature is below 99°C, cooling fan stops operating at high speed.
- When coolant temperature is below 93°C, cooling fan stops operating at low speed.

شماتیک مدار روغن کاری

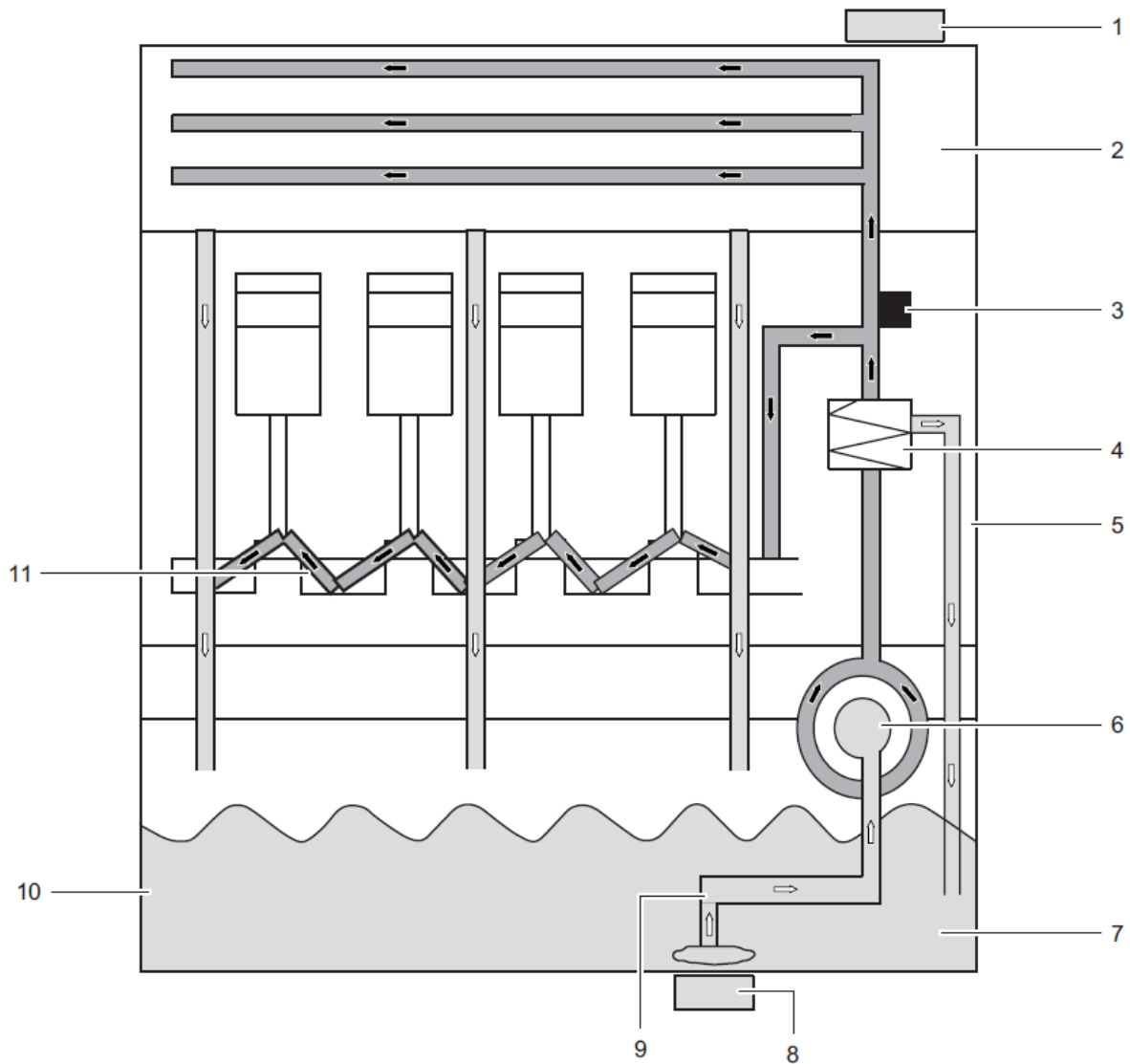

1 - Oil Filler Cap	2 - Cylinder Head
3 - Oil Pressure Switch	4 - Oil Filter
5 - Cylinder Block	6 - Oil Pump
7 - Engine Oil	8 - Drain Plug
9 - Oil Strainer	10 - Oil Pan
11 - Crankshaft	

تست فشار روغن

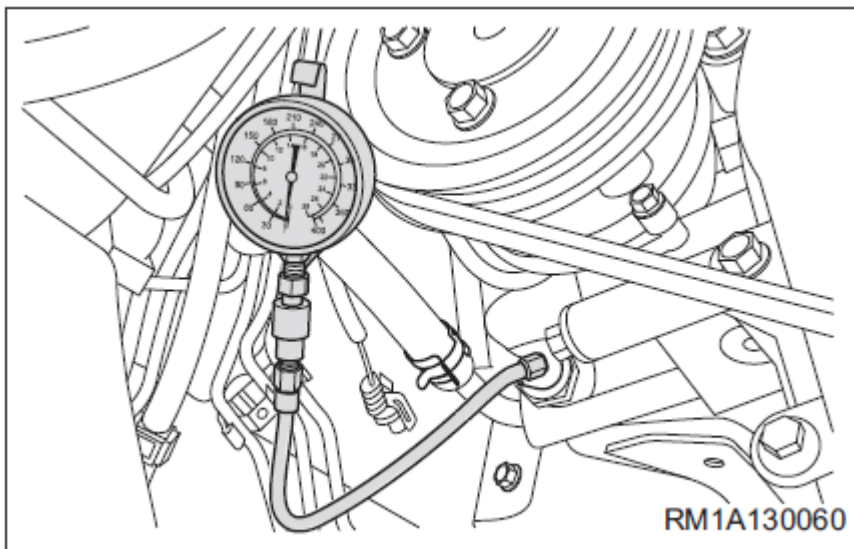
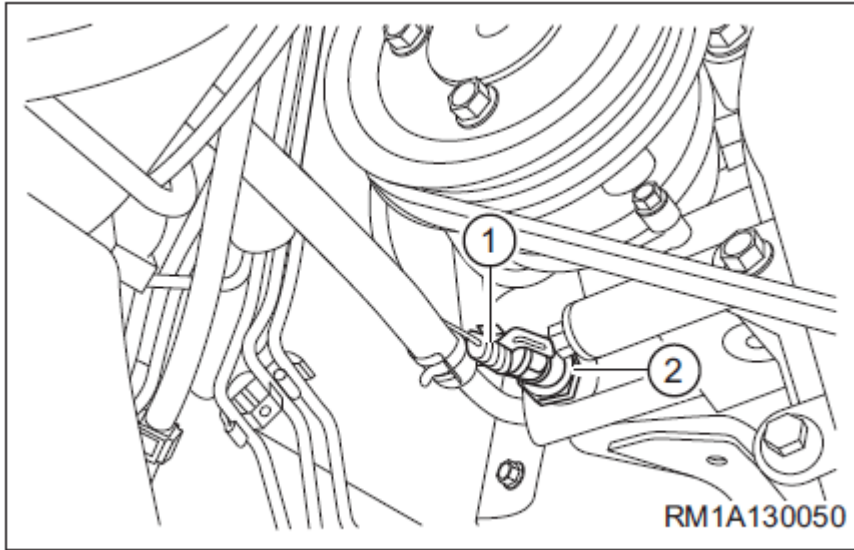



• **Bypass Valve of Oil Filter**

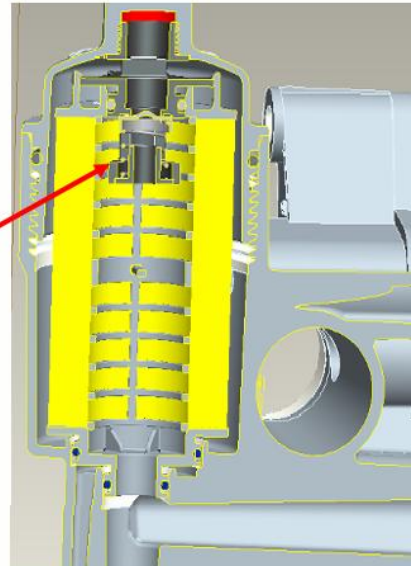

Question: What is the function of the bypass valve in the figure?

When the oil filter is blocked, this valve will open so that unfiltered oil can continue to be supplied to the engine for lubrication to prevent wear due to lack of oil.

- Oil Cooler

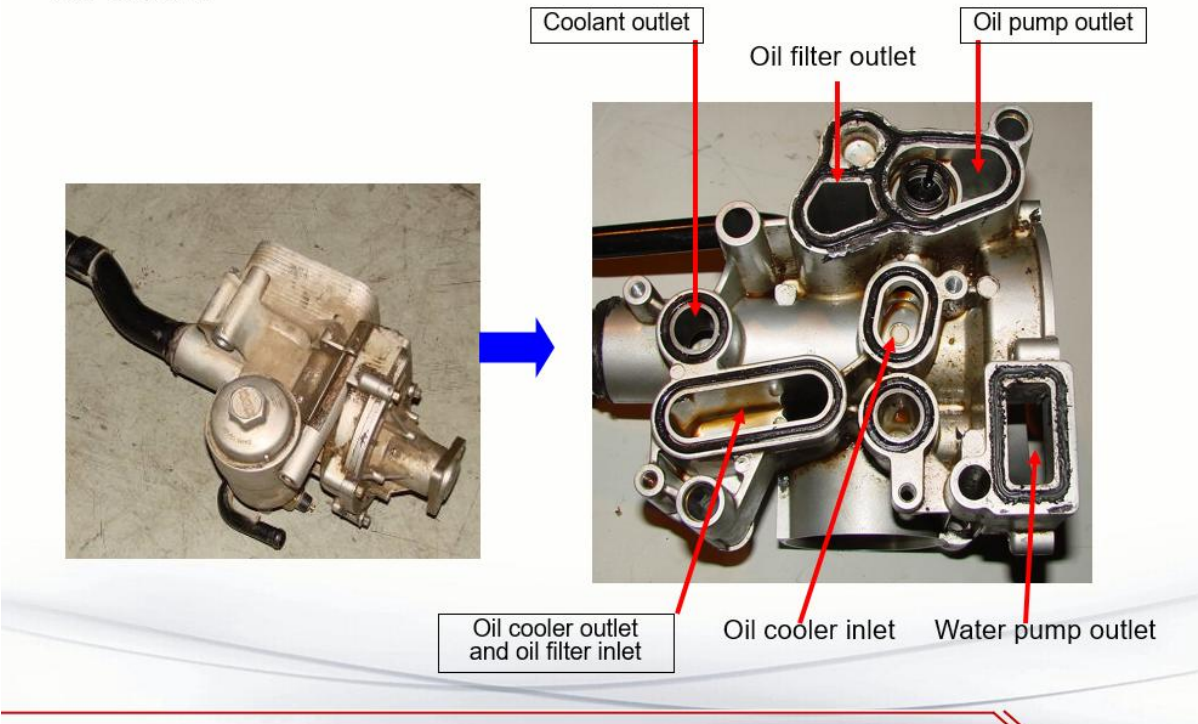

- Oil Cooler

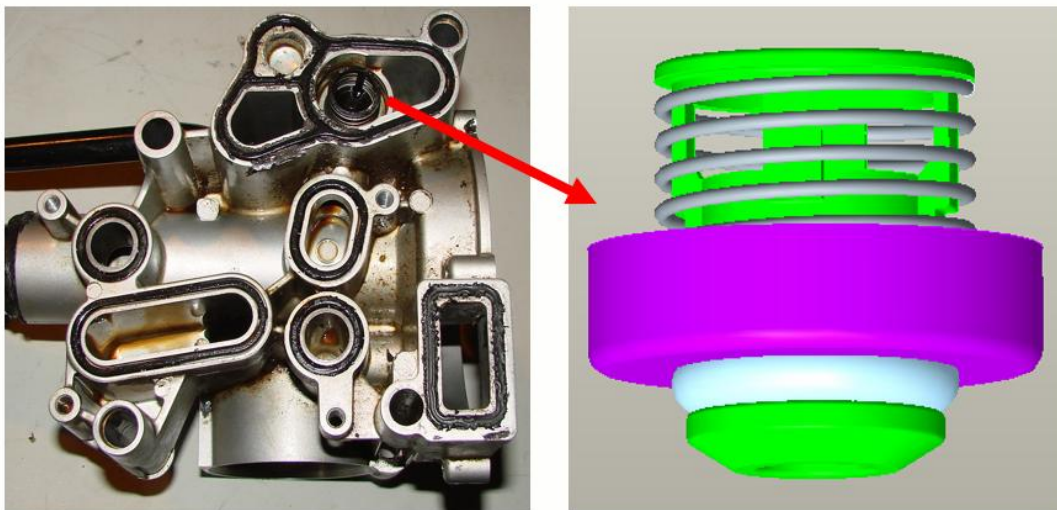

Question: What is the function of the valve in the figure?

It is called check valve and used to prevent oil in the main oil passage from returning to the oil pan rapidly after engine flameout.

- DVVT Control Strategy**

Traveling State	Intake Valve	Exhaust Valve	Target	Result
Idle	Unchanged	Unchanged	Minimum valve overlap angle	Stabilizing the idling speed
Low engine load	Advanced	Retarded	Small valve overlap angle	Stabilizing the engine output
Intermediate engine load	Advanced	Retarded	Intermediate valve overlap angle for pumping loss elimination	Achieving more optimum fuel economy in case of low emission
High load and low RPM	Advanced	Retarded	Large valve overlap angle	Improving the torque under low-intermediate load
High load and high RPM	Advanced	Retarded	Maximum valve overlap angle	Improving the engine output



Intake phaser

Exhaust phaser

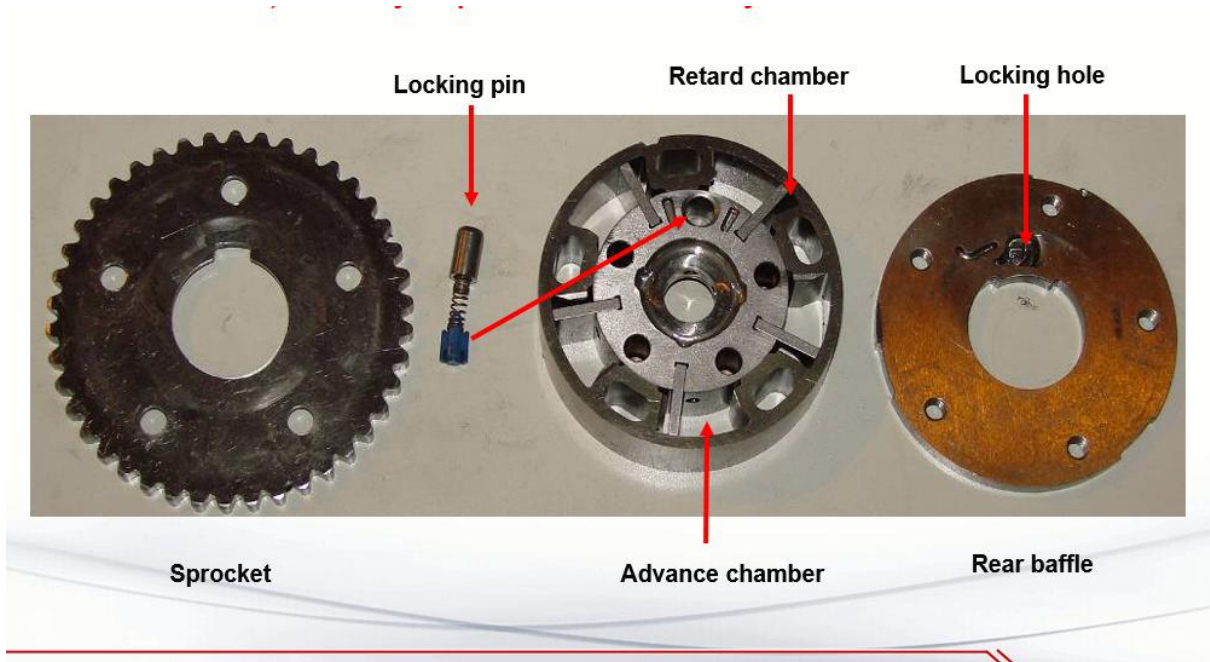
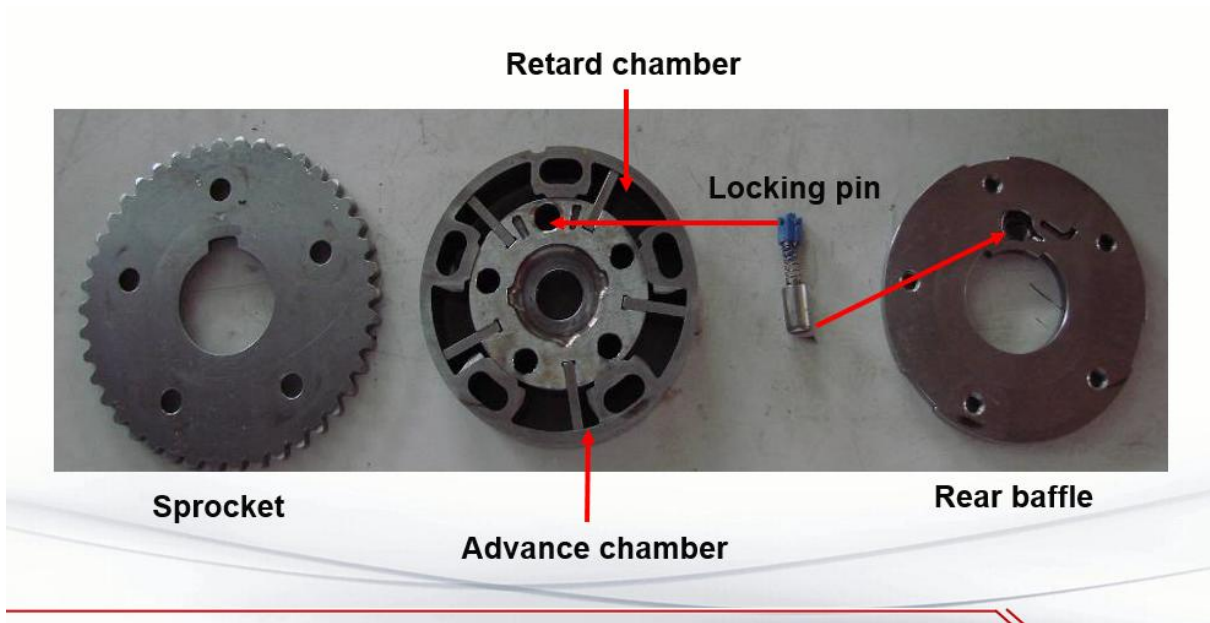

Exhaust Phaser



Question: Why is only the exhaust phaser set with a return spring?

- a. A spring is required for smooth phaser return;
- b. The advance and retard properties of the phaser can be adjusted through the change of the return spring.

Initial Position of Intake/Exhaust Phaser

- The initial position of the intake phaser is the **maximum retard** position;
- The initial position of the exhaust phaser is the **maximum advance** position.

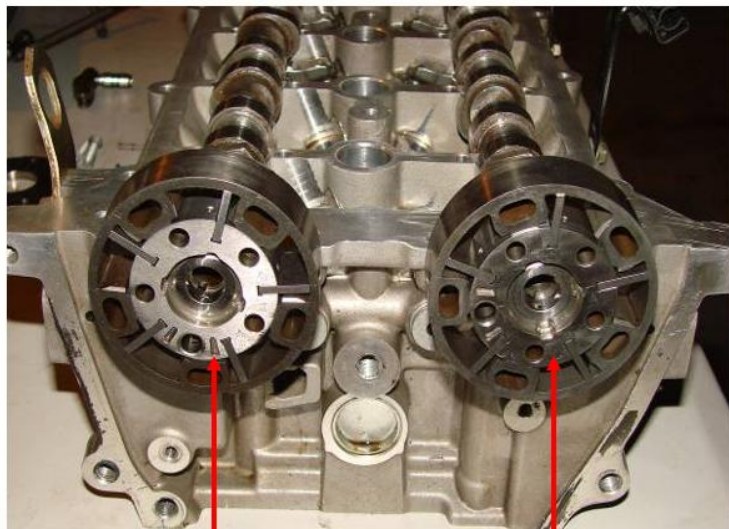

Exhaust phaser

Intake phaser

Solenoid Valve

- The ECM is controlled by the PWM technique;

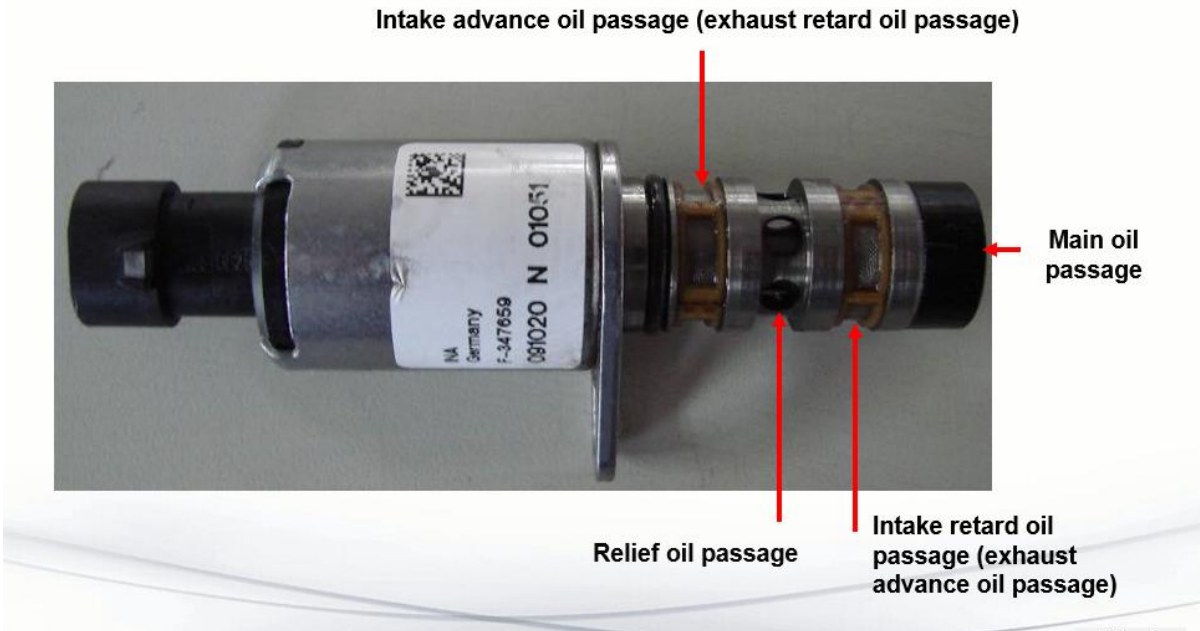

Internal Structure of Solenoid Valve

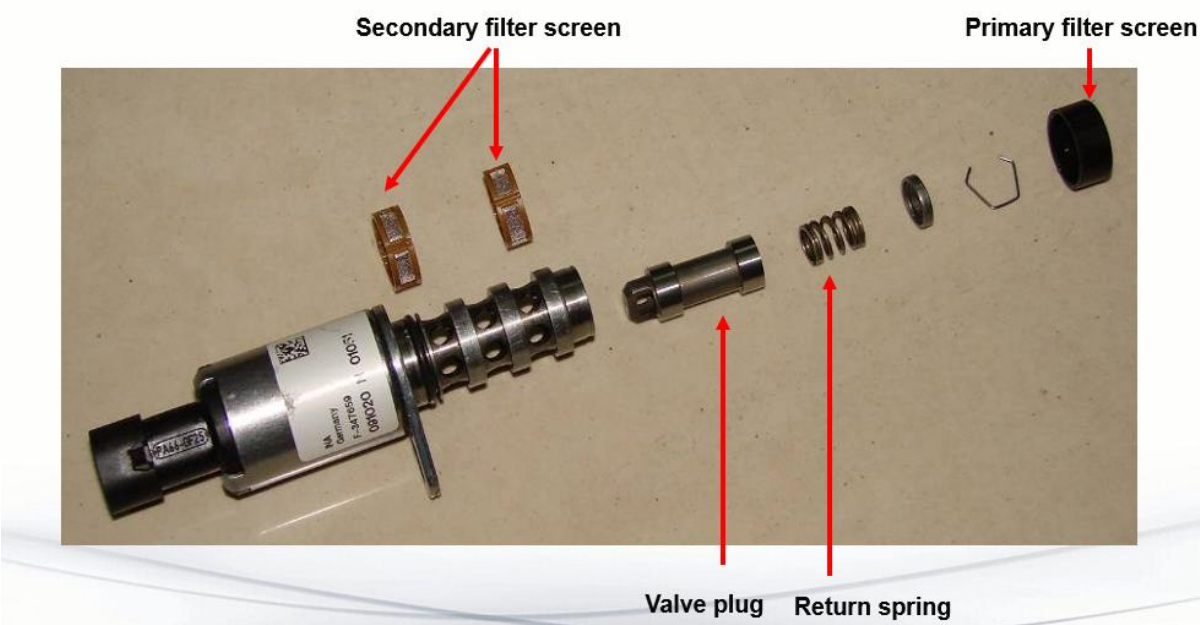

Variable Intake System

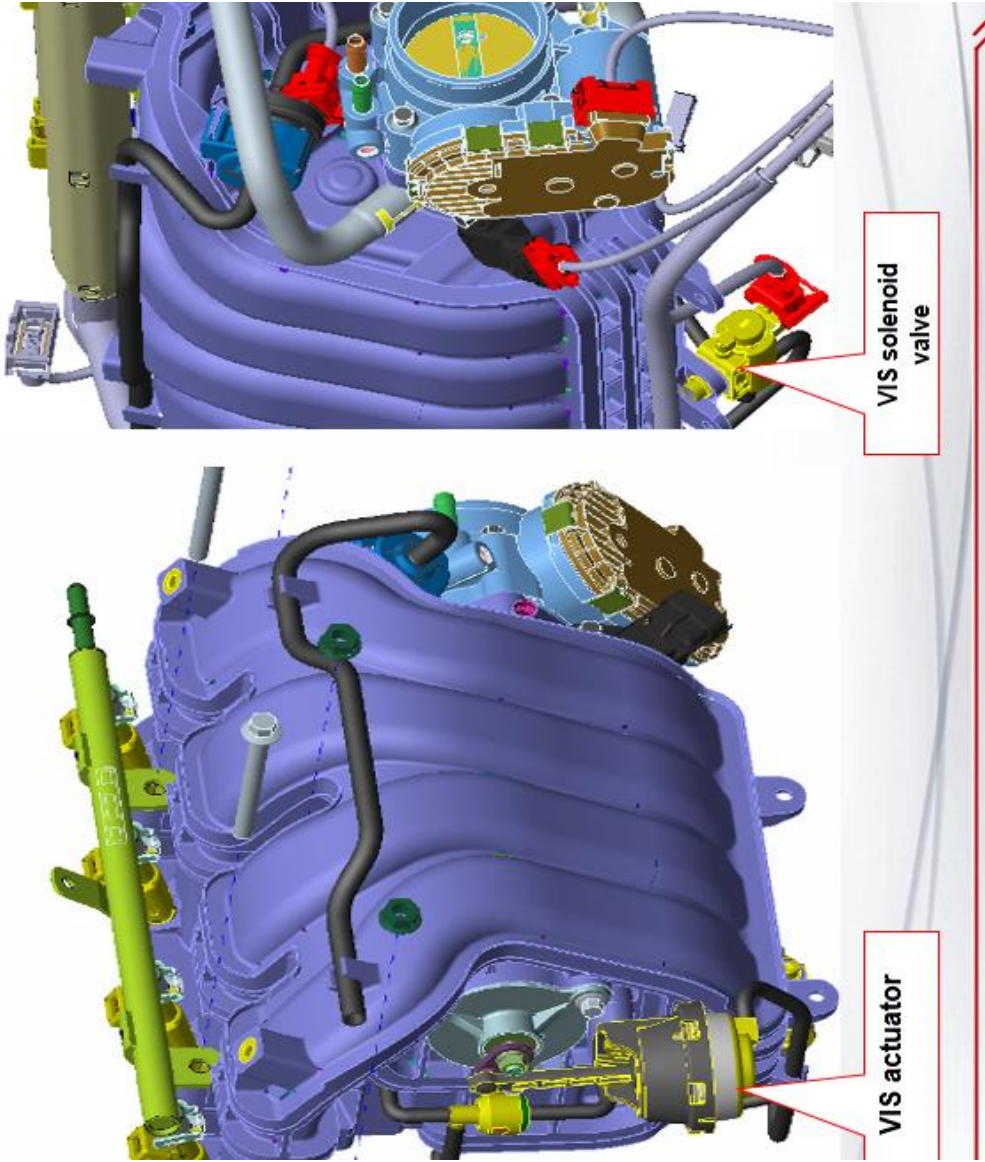

Internal Structure

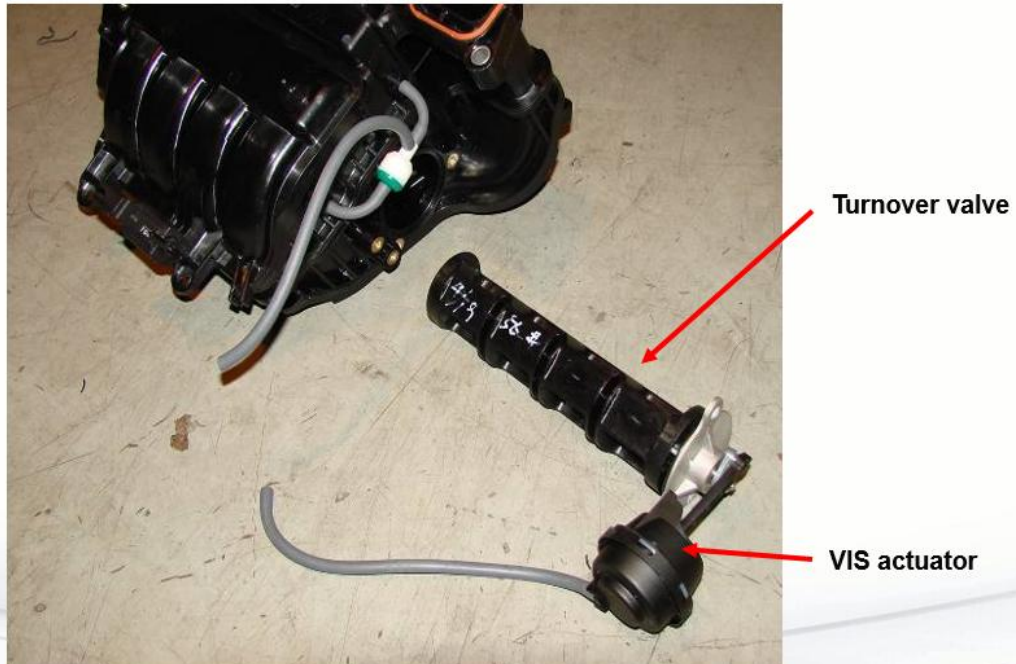

• **Vacuum Pipe**

Question: What is the function of the check valve?

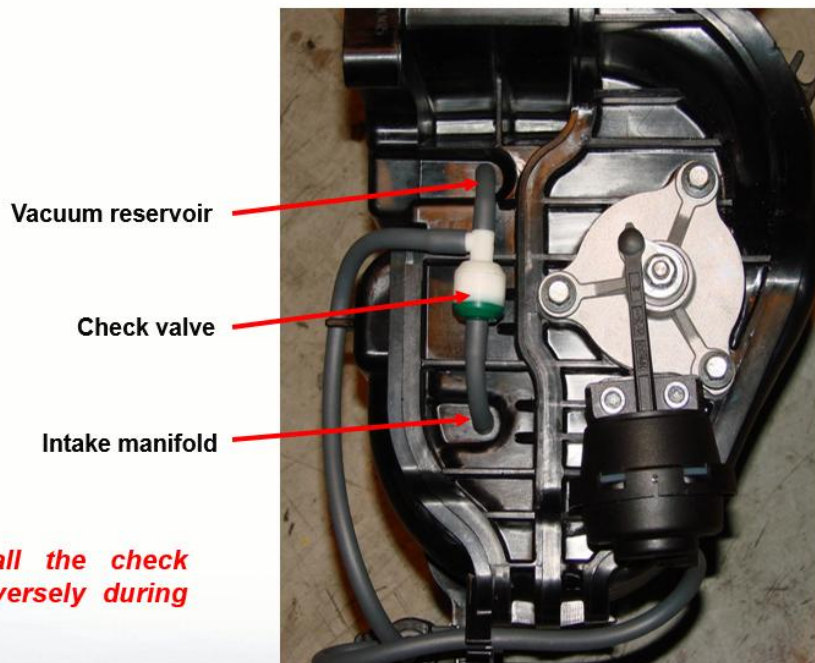

Attention: Never install the check valve in the figure reversely during maintenance!

VIS Control Principle - at Low Speed

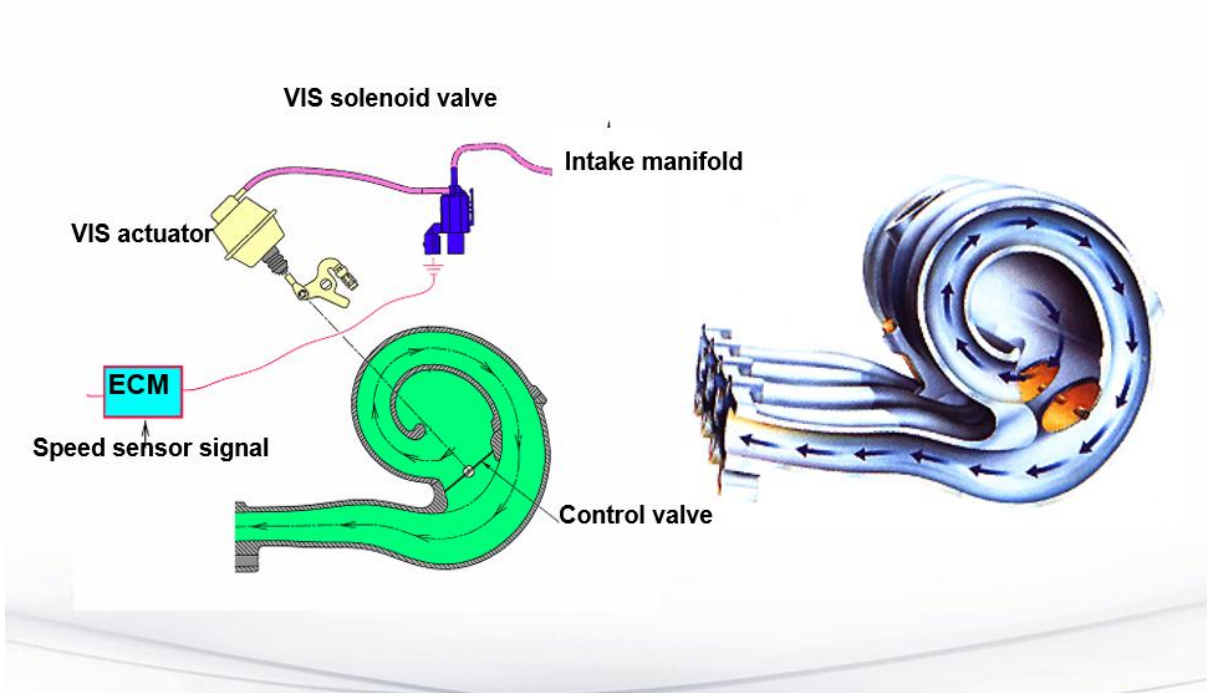

VIS Control Principle - at High Speed

