

Engine (G6BA - Gasoline 2.7)

GENERAL

TIMING SYSTEM

CYLINDER HEAD ASSEMBLY

ENGINE AND TRANSAXLE ASSEMBLY

ENGINE BLOCK

COOLING SYSTEM

LUBRICATION SYSTEM

INTAKE AND EXHAUST SYSTEM

GENERAL

SPECIFICATIONS E19297D6

Description	Specifications	Limit
General Type Number of cylinder Bore Stroke Total displacement Compression ratio Firing order Valve timing Intake valve Opens (BTDC) Closes (ABDC) Exhaust valve Opens (BBDC) Closes (ATDC)	V-type, DOHC 6 86.7mm (3.4133in.) 75mm (2.9528in.) 2,656cc 10 : 1 1-2-3-4-5-6 6° 46° 38° 14°	
Camshaft Drive mechanism Cam height Intake Exhaust Journal diameter Bearing oil clearance End play	Cogged type belt 43.95 ~ 44.15mm (1.7303 ~ 1.7382in.) 43.95 ~ 44.15mm (1.7303 ~ 1.7382in.) 25.964 ~ 25.980mm (1.0222 ~ 1.0228in.) 0.02 ~ 0.061mm (0.0007 ~ 0.0024in.) 0.1 ~ 0.15mm (0.0039 ~ 0.0059in.)	43.45mm (1.7106in.) 43.45mm (1.7106in.) 25.914mm (1.0202in.) 0.1mm (0.0039in.)
Cylinder head Flatness of cylinder head surface Flatness of manifold mounting surface Intake Exhaust Valve guides hole diameter 0.05 (0.002) O.S. 0.25 (0.010) O.S. 0.50 (0.020) O.S. Intake valve seat ring hole diameter 0.3 (0.012) O.S. Exhaust valve seat ring hole diameter 0.3 (0.012) O.S.	Max. 0.03mm (0.0012in.) Max. 0.15mm (0.0059in.) Max. 0.15mm (0.0059in.) 11.05 ~ 11.068mm (0.435 ~ 0.436in.) 11.25 ~ 11.268mm (0.443 ~ 0.444in.) 11.50 ~ 11.518mm (0.453 ~ 0.453in.) 33.300 ~ 33.325mm (1.311 ~ 1.312in.) 28.600 ~ 28.621mm (1.126 ~ 1.127in.)	0.05mm (0.0020in.) 0.15mm (0.0059in.) 0.15mm (0.0059in.)
Valve Overall length Intake Exhaust Stem diameter Intake Exhaust Face angle Margin Intake Exhaust Clearance (Stem-to-guide) Intake Exhaust	96.1mm (3.783in.) 97.15mm (3.825in.) 5.965 ~ 5.98mm (0.235 ~ 0.2354in.) 5.95 ~ 5.965mm (0.234 ~ 0.235in.) 45° ~ 45.5° 1.0mm (0.0394in.) 1.3mm (0.0512in.) 0.02 ~ 0.05mm (0.008 ~ 0.0020in.) 0.030 ~ 0.065mm (0.0012 ~ 0.0026in.)	0.5mm (0.0197in.) 0.8mm (0.0315in.) 0.10mm (0.0039in.) 0.13mm (0.0051in.)

GENERAL

EMB -3

Description	Specifications	Limit
Valve spring Free length Load Out of squareness	42.5mm (1.6732in.) 21kg/35mm (48.4lb/1.3780in.) Max. 1.5°	41.5mm (1.6339in.) 21.9kg/34mm (48.4lb/1.3386in.) Max. 3°
Piston Diameter (Standard) Clearance (Piston-to-cylinder) Ring groove width No.1 No.2 Oil Piston for service	86.68 ~ 86.71mm (3.413 ~ 3.414in.) 0.01 ~ 0.03mm (0.0004 ~ 0.0012in.) 1.230 ~ 1.250mm (0.0484 ~ 0.0492in.) 1.220 ~ 1.250mm (0.0480 ~ 0.0488in.) 2.515 ~ 2.535mm (0.0990 ~ 0.0998in.) 0.25mm (0.010in.), 0.50mm (0.020in.)	
Piston ring Number of rings per piston Compression ring Oil ring Compression ring type No.1 No.2 Oil ring type Ring end gap No.1 No.2 Oil ring side rail Ring side clearance No.1 No.2 Rings for service	3 2 1 Inner bevel type Under cut type 3-piece type 0.20 ~ 0.35mm (0.0079 ~ 0.0138in.) 0.37 ~ 0.52mm (0.0146 ~ 0.0205in.) 0.2 ~ 0.7mm (0.0079 ~ 0.0276in.) 0.04 ~ 0.08mm (0.0016 ~ 0.0031in.) 0.03 ~ 0.07mm (0.0012 ~ 0.0028in.) 0.25mm (0.010in.), 0.50mm (0.020in.)	0.8mm (0.031in.) 0.8mm (0.031in.) 1.0mm (0.039in.) 0.1mm (0.004in.) 0.1mm (0.004in.)
Connecting rod Piston pin installation force Side clearance (big end) Bend Bearing oil clearance	2,450 ~ 12,225N (250 ~ 1,250kg, 551 ~ 2,755lb) 0.10 ~ 0.25mm (0.0039 ~ 0.0098in.) 0.05mm or less/100mm (0.0020in. or less/3.937in.) 0.018 ~ 0.036mm (0.0007 ~ 0.0014in.)	0.4mm (0.016in.) 0.1mm (0.004in.)
Crankshaft Journal O.D. Pin O.D. Out-of-round, taper of journal and pin Taper of journal and pin End play Main bearing of clearance	61.982 ~ 62.000mm (2.4402 ~ 2.4409in.) 47.982 ~ 48.000mm (1.8891 ~ 1.8898in.) Max. 0.003mm (0.0012in.) Max. 0.005mm (0.00020in.) 0.070 ~ 0.250mm (0.0028 ~ 0.0098in.) 0.004 ~ 0.022mm (0.0002 ~ 0.0009in.)	0.4mm (0.016in.) 0.1mm (0.004in.)
Cylinder block Cylinder bore Flatness of gasket surface Out-of-round of cylinder bore	86.7mm (3.4134in.) Max. 0.03mm (0.0012in.) Max. 0.02mm (0.0008in.)	0.05mm (0.002in.)
Oil pump Body clearance Side clearance	0.100 ~ 0.181mm (0.0039 ~ 0.0071in.) 0.040 ~ 0.095mm (0.0016 ~ 0.0037in.)	
Relief spring Free height Load	43.8mm (1.724in.) 4.6kg/39.3mm (10lb/1.548in.)	

EMB -4

ENGINE (G6BA - GASOLINE 2.7)

Description	Specifications	Limit
Oil filter Type Engine oil pressure Cooling method Cooling system quantity	Cartridge, full flow 50kPa (7.3psi) or more [Conditions : Oil temperature is 75 to 90°C (167 to 194°F)] Engine coolant cooling, forced circulation with electric fan 7.0lit (7.4U.S.qts., 6.1Imp.qts)	
Thermostat Type Normal opening temperature Opening temperature range Wide open temperature	Wax pellet type with jiggle valve 82 ± 2.0°C (179.6 ± 3.6°F) 80 ~ 84°C (176 ~ 183.2°F) 95°C (203°F)	
Radiator cap Main valve opening pressure Main valve closing pressure Vacuum valve opening pressure	107.9 ± 14.7kPa (1.1 ± 0.15kg/cm ² , 15.65 ± 2.13psi) 83.4kPa (0.85kg/cm ² , 12.1psi) -6.86kPa (-0.07kg/cm ² , -1.00psi)	
Air cleaner Type Element	Dry Paper type	
Exhaust pipe Muffler Suspend system	Expansion resonance type Rubber hangers	

SERVICE STANDARDS

Standard value	
Coolant concentration	
Tropical areas	40%
Other areas	50%

COOLANT

Engine coolant	Ethlylen glycol base for aluminum radiator
----------------	--

SEALANT

Engine coolant temperature sensor	LOCTITE 262 or equivalent, Three bond No.1324 or equivalent.
Oil pressure switch	3M ATD No.8660 or Three bond No.1141E
PCV valve	LOCTITE 242 or equivalent

GENERAL**EMB -5****TIGHTENING TORQUE**

Item	N.m	kgf.cm	lbf.ft
Camshaft sprocket bolt	90 ~ 110	900 ~ 1,100	65 ~ 85
Cylinder head cover bolt	8 ~ 10	80 ~ 100	5.8 ~ 7.2
Main bearing cap bolt M10 M8	27~33 + (90°~94°) 13~19 + (90°~94°)	270~300 + (90°~94°) 130~190 + (90°~94°)	19.5~24 + (90°~94°) 10~14 + (90°~94°)
Connecting rod bolt	16~20 + (90°~94°)	160~200 + (90°~94°)	12~15 + (90°~94°)
Cylinder head bolt(Cold engine)	25 + (58°~62°) + (43°~47°)	250 + (58°~62°) + (43°~47°)	18 + (58°~62°) + (43°~47°)
Oil pan drain plug	35 ~ 45	350 ~ 450	25 ~ 33
Lower oil pan bolt	10 ~ 12	100 ~ 120	7 ~ 9
Upper oil pan bolt [10 × 38mm (0.937 × 1.4961in.)] [8 × 22mm (0.3150 × 0.8661in.)] [161.5mm (6.3582in.)] [152.5mm (6.0039in.)]	30 ~ 42 19 ~ 28 5 ~ 7 5 ~ 7	300 ~ 420 190 ~ 280 50 ~ 70 50 ~ 70	22 ~ 30 14 ~ 20 4 ~ 5 4 ~ 5
Oil screen bolt	15 ~ 22	150 ~ 220	11 ~ 16
Oil pump case bolt	12 ~ 15	120 ~ 150	9 ~ 11
Oil relief valve plug	40 ~ 50	400 ~ 500	29 ~ 36
Oil pressure switch	15 ~ 22	150 ~ 220	11 ~ 16
Oil pressure cover screw	8 ~ 12	80 ~ 120	6 ~ 9
Oil filter	12 ~ 16	120 ~ 160	9 ~ 12
Drive plate and adapte	73 ~ 77	730 ~ 770	53 ~ 56
Air cleaner body installation bolt	8 ~ 12	80 ~ 120	6 ~ 9
Surge tank stay	15 ~ 20	150 ~ 200	11 ~ 14
Air intake surge tank to intake manifold(bolt)	15 ~ 20	150 ~ 200	11 ~ 14
Air intake surge tank to intake manifold(nut)	15 ~ 20	150 ~ 200	11 ~ 14
Intake manifold to cylinder head	19 ~ 21	190 ~ 210	14 ~ 15
Heat protector exhaust manifold	12 ~ 15	120 ~ 150	9 ~ 11
Exhaust manifold to cylinder head (Self-locking nut)	30 ~ 35	300 ~ 350	22 ~ 26
Oil level gauge guide to engine	12 ~ 15	120 ~ 150	9 ~ 11
Water outlet fitting bolt	17 ~ 20	170 ~ 200	12 ~ 14
Power steering oil pump bracket to cylinder head	17 ~ 26	170 ~ 260	12 ~ 19
Crank position sensor wheel screw	5 ~ 6	50 ~ 60	3.6 ~ 4.3
Engine mounting insulator bolt	50 ~ 65	500 ~ 650	36 ~ 47
Engine mounting bracket nut	60 ~ 80	600 ~ 800	43 ~ 58
Engine mounting bracket bolt	60 ~ 80	600 ~ 800	43 ~ 58
Engine support bracket bolt	60 ~ 70	600 ~ 700	43 ~ 51
Front roll stopper bracket sub frame bolt	50 ~ 65	500 ~ 650	36 ~ 47

EMB -6

ENGINE (G6BA - GASOLINE 2.7)

Item	N.m	kgf.cm	lbf.ft
Front roll stopper insulator bolt and nut	50 ~ 65	500 ~ 650	36 ~ 47
Rear roll stopper bracket to sub frame	50 ~ 65	500 ~ 650	36 ~ 47
Rear roll stopper insulator bolt and nut	50 ~ 65	500 ~ 650	36 ~ 47
Transaxle mounting bracket bolt	50 ~ 65	500 ~ 650	36 ~ 47
Transaxle mounting insulator bolt	90 ~ 110	900 ~ 1,100	65 ~ 80
Fuel hose clamp to rear cylinder head assembly	12 ~ 15	120 ~ 150	9 ~ 11
Transaxle mounting plate	10 ~ 12	100 ~ 120	7 ~ 9
Rear plate	10 ~ 12	100 ~ 120	7 ~ 9
Oil seal case	10 ~ 12	100 ~ 120	7 ~ 9
Crankshaft pulley bolt	180 ~ 190	1,800 ~ 1,900	130 ~ 138
Timing belt cover bolt	10 ~ 12	100 ~ 120	7 ~ 9
Engine hanger bracket to engine	20 ~ 27	200 ~ 270	14 ~ 20
Alternator mounting bracket to engine	20 ~ 30	200 ~ 300	14 ~ 22
Alternator mounting nut (Engine front case side)	20 ~ 30	200 ~ 300	14 ~ 22
Alternator mounting bolt (Alternator mounting bracket side)	20 ~ 30	200 ~ 300	14 ~ 22
Starter to transmission(nut)	20 ~ 30	200 ~ 300	14 ~ 22
Starter to transmission(bolt)	27 ~ 34	270 ~ 340	20 ~ 25
Drive belt pulley bolt	35 ~ 55	350 ~ 550	25 ~ 40
Drive belt tensioner bolt	20 ~ 27	200 ~ 270	14 ~ 20
Engine coolant pump to cylinder block bolt (Head mark "7" mark)	15 ~ 22	150 ~ 200	11 ~ 16
Engine coolant temperature sensor	20 ~ 40	200 ~ 400	14 ~ 29
Engine coolant inlet fitting attaching bolt	17 ~ 20	170 ~ 200	12 ~ 14
Throttle body to surge tank bolt	15 ~ 20	150 ~ 200	11 ~ 14
Oxygen sensor to exhaust manifold	40 ~ 50	400 ~ 500	29 ~ 36
Front exhaust pipe to exhaust manifold nut	30 ~ 40	300 ~ 400	22 ~ 29
Front exhaust pipe to catalytic converter bolt	40 ~ 60	400 ~ 600	29 ~ 43
Catalytic converter to center exhaust pipe nut	40 ~ 60	400 ~ 600	29 ~ 43
Center exhaust pipe to main muffler nut	40 ~ 60	400 ~ 600	29 ~ 43
Main muffler hanger support bracket bolt	10 ~ 15	100 ~ 150	7 ~ 11
Delivery pipe installation bolt	10 ~ 15	100 ~ 150	7 ~ 11
Timing belt tensioner pulley bolt	43 ~ 55	430 ~ 550	31 ~ 40
Timing belt idler pulley bolt	50 ~ 60	500 ~ 600	36 ~ 43
Timing belt tensioner arm fixed bolt	35 ~ 55	350 ~ 550	25 ~ 40
Auto tensioner fixed bolt	20 ~ 27	200 ~ 270	14 ~ 20
Accelerator cable bracket	4 ~ 6	40 ~ 60	3 ~ 4
Spark plug	20 ~ 30	200 ~ 300	14 ~ 22

COMPRESSION

 **NOTE**

If there is lack of power, excessive oil consumption or poor fuel economy, measure the compression pressure.

1. Warm up and stop engine
Allow the engine to warm up to normal operating temperature.
2. Remove ignition coils. (See EE group - ignition)
3. Remove spark plugs.
Using a 16mm plug wrench, remove the 6 spark plugs.
4. Check cylinder compression pressure
 - a. Insert a compression gauge into the spark plug hole.

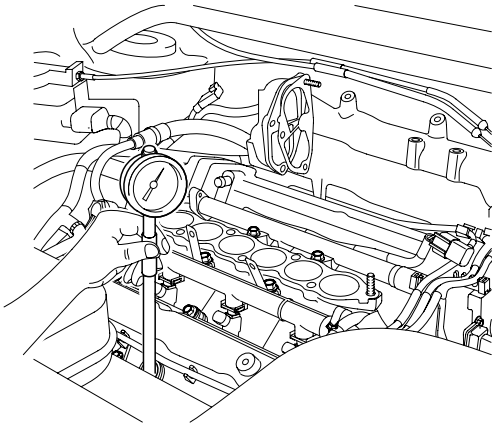

LUIF001A

- b. While cranking the engine, measure the compression pressure.

 **NOTE**

Always use a fully charged battery to obtain engine speed of 250 rpm or more.

- c. Repeat steps (a) through (b) for each cylinder.

 **NOTE**

This measurement must be done in as short a time as possible.

- d. If the cylinder compression in 1 or more cylinders is low, pour a small amount of engine oil into the cylinder through the spark plug hole and repeat steps (a) through (b) for cylinders with low compression.
 - If adding oil helps the compression, it is likely that the piston rings and/or cylinder bore are worn or damaged.
 - If pressure stays low, a valve may be sticking or seating is improper, or there may be leakage past the gasket.
 5. Reinstall spark plugs. (See EE group - ignition)
 6. Install ignition coils. (See EE group - ignition)

Compression pressure :
1,420kPa (14.5kgf/cm², 206psi)
Minimum pressure :
1,270kPa (13kgf/cm², 184psi)
Difference between each cylinder :
100kPa (1.0kgf/cm², 15psi) or less

TROUBLESHOOTING

E92D22FA

Symptom	Suspect area	Remedy (See page)
Engine misfire with abnormal internal lower engine noises.	Loose or improperly installed engine flywheel.	Repair or replace the flywheel as required.
	Worn piston rings (Oil consumption may or may not cause the engine to misfire.)	Inspect the cylinder for a loss of compression. Repair or replace as required.
	Worn crankshaft thrust bearings	Replace the crankshaft and bearings as required
Engine misfire with abnormal valve train noise.	Stuck valves. (Carbon buildup on the valve stem)	Repair or replace as required
	Excessive worn or mis-aligned timing chain	Replace the timing chain and sprocket as required.
	Worn camshaft lobes.	Replace the camshaft and valve lifters.
Engine misfire with coolant consumption	<ul style="list-style-type: none"> Faulty cylinder head gasket and/or cranking or other damage to the cylinder head and engine block cooling system. Coolant consumption may or may not cause the engine to overheat. 	<ul style="list-style-type: none"> Inspect the cylinder head and engine block for damage to the coolant passages and/or a faulty head gasket. Repair or replace as required.
Engine misfire with excessive oil consumption	Worn valves, guides and/or valve stem oil seals.	Repair or replace as required.
	Worn piston rings. (Oil consumption may or may not cause the engine to misfire)	<ul style="list-style-type: none"> Inspect the cylinder for a loss of compression. Repair or replace as required.
Engine noise on start-up, but only lasting a few seconds.	Incorrect oil viscosity	<ul style="list-style-type: none"> Drain the oil. Install the correct viscosity oil.
	Worn crankshaft thrust bearing.	<ul style="list-style-type: none"> Inspect the thrust bearing and crankshaft. Repair or replace as required.
Upper engine noise, regardless of engine speed.	Low oil pressure	Repair or replace as required.
	Broken valve spring.	Replace the valve spring.
	Worn or dirty valve lifters.	Replace the valve lifters.
	Stretched or broken timing chain and/or damaged sprocket teeth.	Replace the timing chain and sprockets.
	Worn timing chain tensioner, if applicable.	Replace the timing chain tensioner as required.
	Worn camshaft lobes.	<ul style="list-style-type: none"> Inspect the camshaft lobes. Replace the timing camshaft and valve lifters as required.
	Worn valve guides or valve stems.	Inspect the valves and valve guides, then repair as required.
	Stuck valves. (Carbon on the valve stem or valve seat may cause the valve to stay open.	Inspect the valves and valve guides, then repair as required.

Symptom	Suspect area	Remedy (See page)
Lower engine noise, regardless of engine speed	Low oil pressure.	Repair or required.
	Loose or damaged flywheel.	Repair or replace the flywheel.
	Damaged oil pan, contacting the oil pump screen.	<ul style="list-style-type: none">• Inspect the oil pan.• Inspect the oil pump screen.• Repair or replace as required.
	Oil pump screen loose, damaged or restricted.	<ul style="list-style-type: none">• Inspect the oil pump screen.• Repair or replace as required.
	Excessive piston-to-cylinder bore clearance.	<ul style="list-style-type: none">• Inspect the piston, piston pin and cylinder bore.• Repair as required.
	Excessive piston pin-to-clearance	<ul style="list-style-type: none">• Inspect the piston, piston pin and the connecting rod.• Repair or replace as required.
	Excessive connecting rod bearing rod clearance	Inspect the following components and repair as required. <ul style="list-style-type: none">• The connecting rod bearings.• The connecting rods.• The crankshaft.• The crankshaft journal.
	Excessive crankshaft bearing clearance	Inspect the following components, and repair as required. <ul style="list-style-type: none">• The crankshaft bearing.• The crankshaft journals.
	Incorrect piston, piston pin and connecting rod installation	<ul style="list-style-type: none">• Verify the piston pins and connecting rods are installed correctly.• Repair as required.
Engine noise under load	Low oil pressure	Repair or replace as required.
	Excessive connecting rod bearing clearance	Inspect the following components and repair as required : <ul style="list-style-type: none">• The connecting rod bearings.• The connecting rods.• The crankshaft
	Excessive crankshaft bearing clearance	Inspect the following components, and repair as required. <ul style="list-style-type: none">• The crankshaft bearings.• The crankshaft journals.• The cylinder block crankshaft

Symption	Suspect area	Remedy (See page)
Engine will not crank-crankshaft will not rotate	Hydraulically cylinder <ul style="list-style-type: none">Coolant/antifreeze in cylinder.Oil in cylinder.Fuel in cylinder	<ol style="list-style-type: none">1. Remove spark plugs and check for fluid.2. Inspect for broken head gasket.3. Inspect for cracked engine block or cylinder head.4. Inspect for a sticking fuel injector and/or leaking fuel regulator.
	Broken timing chain and/or timing chain gears.	<ol style="list-style-type: none">1. Inspect timing chain and gears.2. Repair as required.
	Material cylinder <ul style="list-style-type: none">Broken valvePiston materialForeign material	<ol style="list-style-type: none">1. Inspect cylinder for damaged components and/or foreign materials.2. Repair or replace as required.
	Seized crankshaft or connecting rod bearings.	<ol style="list-style-type: none">1. Inspect crankshaft and connecting rod bearing.2. Repair as required.
	Bend or broken connecting rod.	<ol style="list-style-type: none">1. Inspect connecting rods.2. Repair as required.
	Broken crankshaft	<ol style="list-style-type: none">1. Inspect crankshaft.2. Repair as required.

SPECIAL TOOLS E78A921C

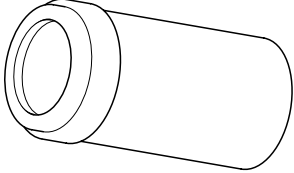
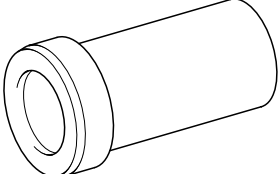
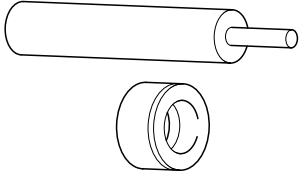
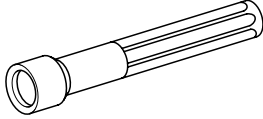
Tool (Number and name)	Illustration	Use
Crankshaft front oil seal installer (09214-33000)	 LUIF002A	Installation of the front oil seal
Camshaft oil seal installer (09214-21000)	 LUIF003A	Installation of the camshaft oil seal
Valve guide installer (09221-3F100 A/B)	 LUIF004A	Remove and installation of the valve guide
Valve stem oil seal installer (09222-22001)	 LUIF005A	Installation of the valve stem oil seal

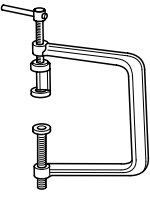
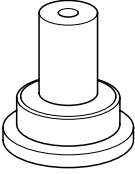
Tool (Number and name)	Illustration	Use
Valve spring compressor & adaptor (09222-28000, 09222-28100)	 LUIF006A	Removal and installation of the intake or exhaust valve
Crankshaft rear oil seal installer (09231-33000)	 LUIF007A	<ol style="list-style-type: none">1. Installation of the engine rear oil seal2. Installation of the crankshaft rear oil seal

TIMING SYSTEM

COMPONENT E5886FA8

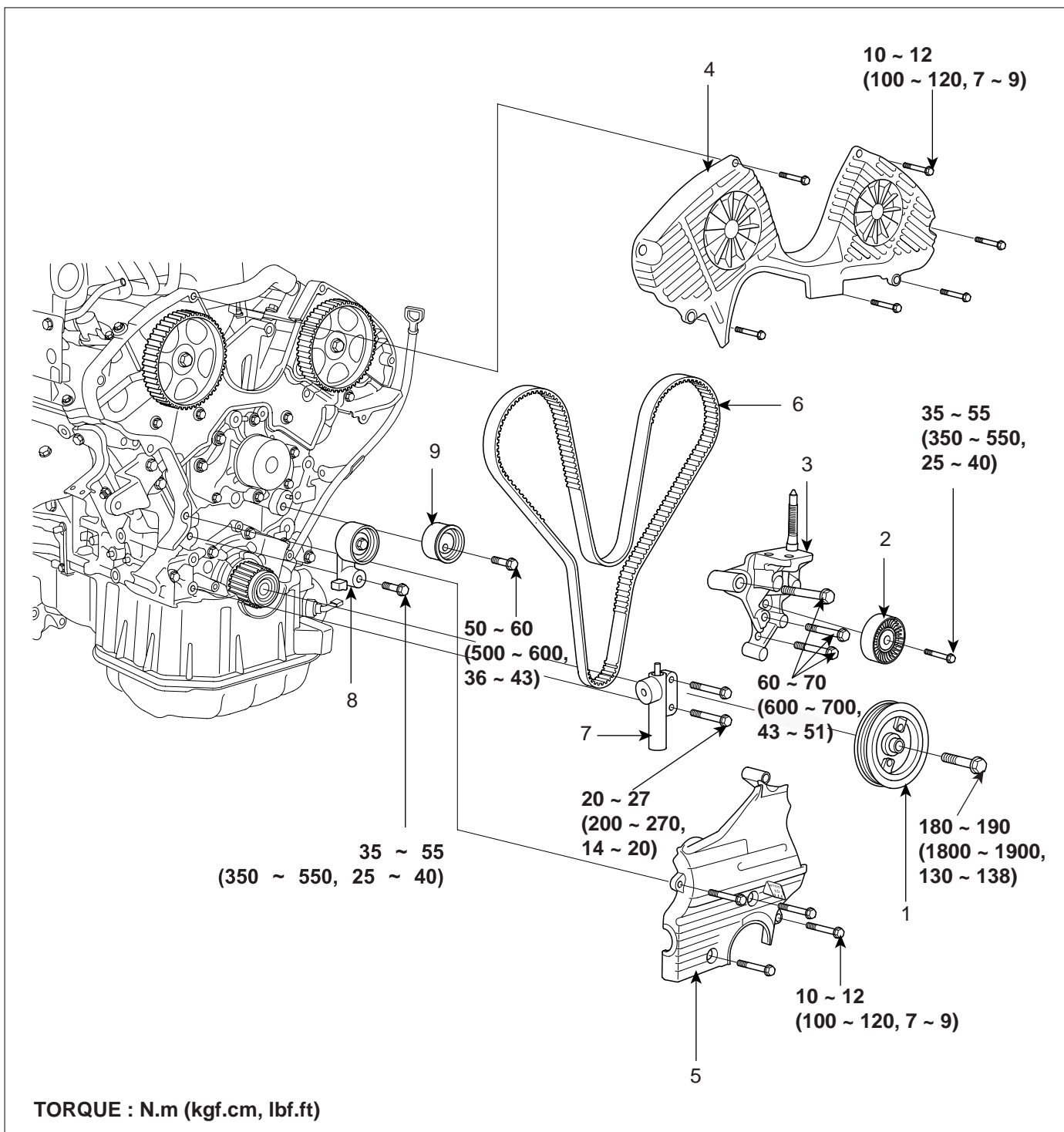

- 1. Crankshaft pulley
- 2. Drive belt idler pulley
- 3. Engine support bracket
- 4. Timing belt upper cover
- 5. Timing belt lower cover

- 6. Timing belt
- 7. Auto tensioner
- 8. Tensioner pulley
- 9. Idler pulley

LUIF008A

EMB -14

ENGINE (G6BA - GASOLINE 2.7)

REMOVAL E5BBCE78

Engine removal is not required for this procedure.

1. Remove the engine cover.
2. Remove RH front wheel.
3. Remove 2bolts(B) and RH side cover(A).

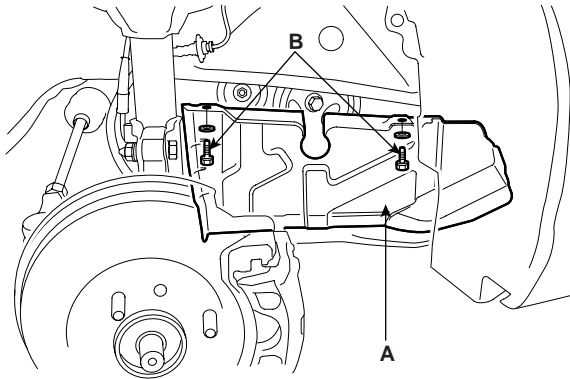

LUIF009A

4. Turn the crankshaft pulley, and align its groove with timing mark " T " of the timing belt cover.

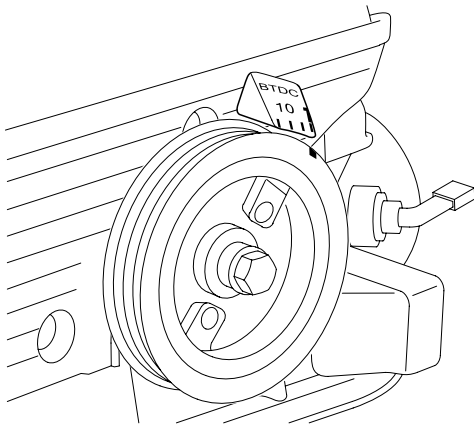

LUIF010A

NOTE

Always turn the crankshaft clockwise.

5. Remove drive belt(A) and belt tensioner(B).

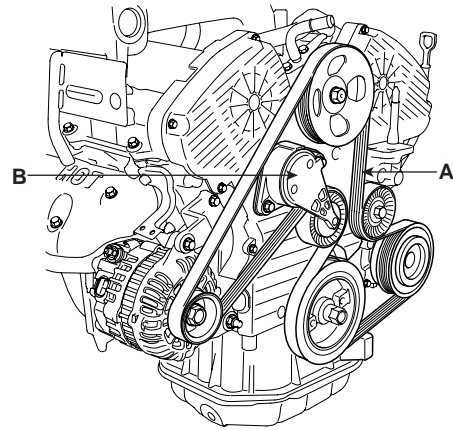

LUIF011A

6. Remove the engine mount bracket.
 - 1) Set the jack to the engine oil pan.

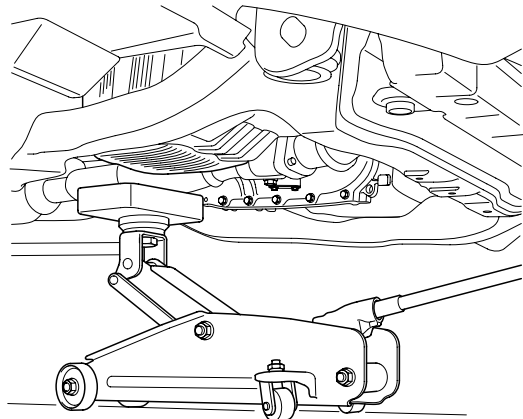

LUIF012A

NOTE

Place wooden block between the jack and engine oil pan.

- 2) Remove the 2bolts, 2nuts and engine mount bracket(A).

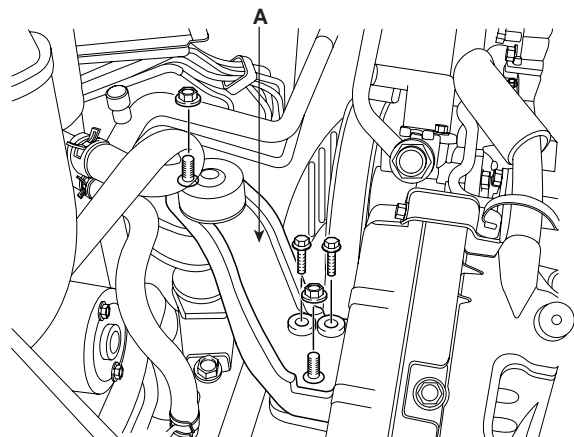

LUIF013A

TIMING SYSTEM

- 7. Remove the power steering pump. (See ST group - power steering pump)
- 8. Remove the 7bolts(B) and timing belt upper cover(A).

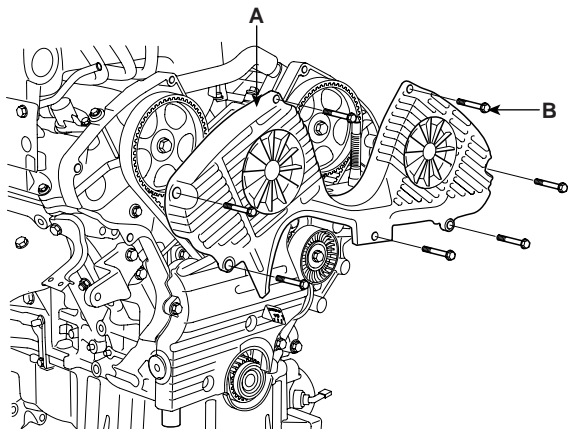

LUIF014A

- 9. Remove the crankshaft pulley bolt and crankshaft pulley(A).

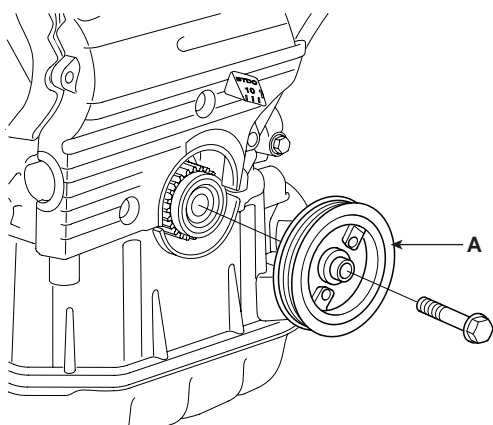

LUIF015A

- 10. Remove the drive belt idler pulley(A).

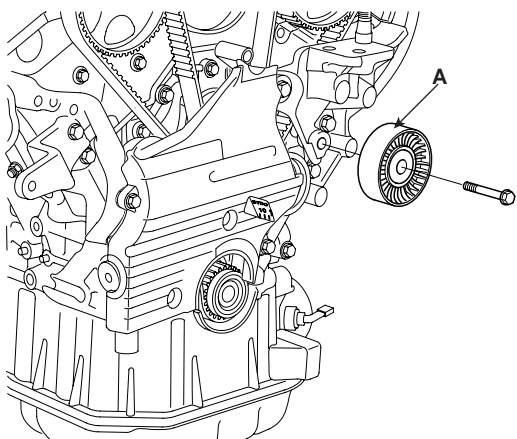

LUIF016A

- 11. Remove the 4bolts(B) and timing belt lower cover(A).

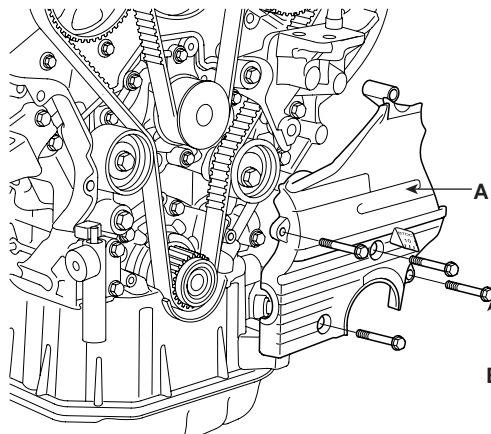

LUIF017A

- 12. Remove the engine support bracket(A).

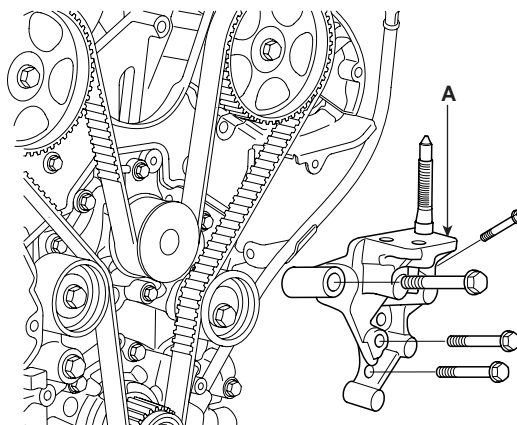

LUIF018A

- 13. Check that timing marks of the camshaft timing pulleys and cylinder head covers are aligned. If not, turn the crankshaft 1revolution(360°).

- 14. Remove timing belt tensioner. Alternately loosen the 2bolts, and remove the tensioner(A).

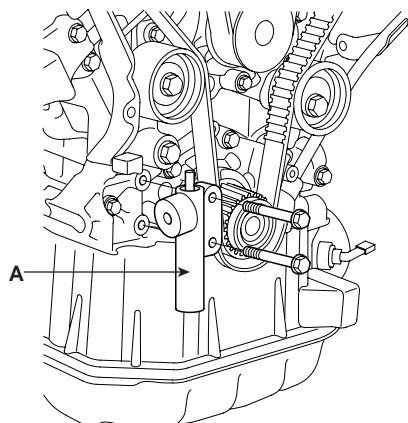

LUIF019A

15. Remove the timing belt(A).

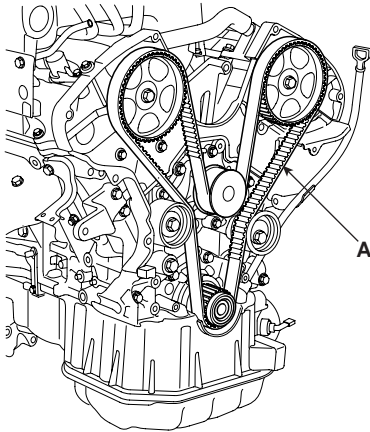

LUIF020A

NOTE

If the timing belt is reused, make an arrow indicating the turning direction to make sure that the belt is reinstalled in the same direction as before.

16. Remove the tensioner pulley(A) and timing belt idler pulley(B).

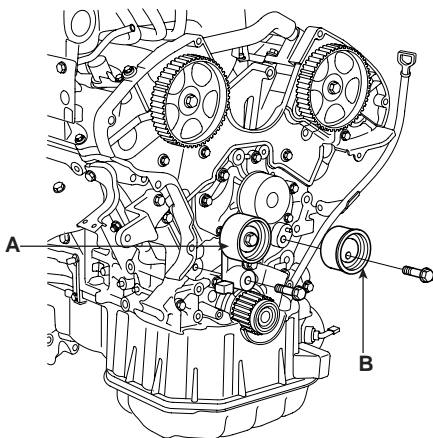

LUIF021A

17. Remove the crankshaft sprocket.
18. Remove camshaft sprockets.
Hold the hexagonal head wrench portion of the camshaft with a wrench and remove the bolt and camshaft sprocket.

CAUTION

Be careful not to damage the cylinder head and valve lifter with the wrench.

INSPECTION EADFDCB3

SPOCKETS, TENSIONER, IDLER

1. Check the camshaft sprocket, crankshaft sprocket, tensioner pulley, and idler pulley for abnormal wear, cracks, or damage. Replace as necessary.
2. Inspect the tensioner pulley and the idler pulley for easy and smooth rotation and check for play or noise. Replace as necessary.

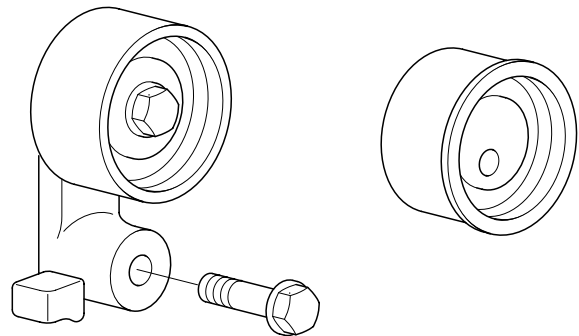

LUIF022A

3. Replace the pulley if there is a grease leak from its bearing.

TIMING BELT

1. Check the belt for oil or dust deposits. Replace, if necessary. Small deposits should be wiped away with a dry cloth or paper. Do not clean with solvent.
2. When the engine is overhauled or belt tension adjusted, check the belt carefully. If any of the following flaws are evident, replace the belt.

NOTE

- Do not bend, twist or turn the timing belt inside out.
- Do not allow the timing belt to come into contact with oil, water and steam.

INSTALLATION EFBFAB09

1. Install the crankshaft sprocket.
Align the pulley set key with the key groove the crankshaft sprocket and slide on the crankshaft sprocket.
2. Install the camshaft sprockets and tighten the bolts to the specified torque.
 - 1) Temporarily install the camshaft sprocket bolts.
 - 2) Hold the hexagonal head wrench portion of the camshaft with a wrench, and tighten the camshaft sprocket bolts.

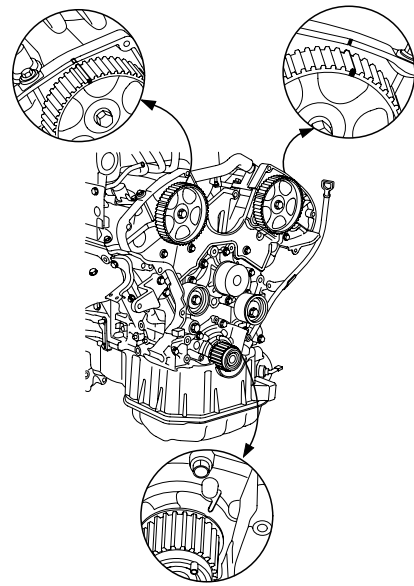

LUIF024A

Tightening torque
Camshaft sprocket bolt
90 ~ 110N.m (900 ~ 1100kgf.cm, 65 ~ 80lbf.ft)

3. Install the idler pulley(B) and the tensioner pulley(A).

Tightening torque
Idler pulley bolt
50 ~ 60N.m (500 ~ 600kgf.cm, 36 ~ 43lbf.ft)
Tensioner arm fixed bolt
35 ~ 55N.m (350 ~ 550kgf.cm, 25 ~ 40lbf.ft)

 **NOTE**

Insert and install the idler pulley to the roll pin that is pressed in the water pump boss.

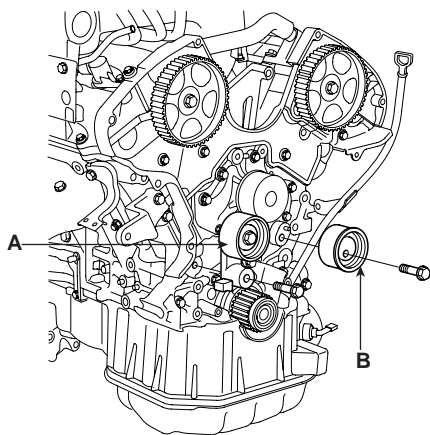

LUIF023A

4. Align the timing marks of the camshaft sprocket and crankshaft sprocket with the No.1 piston placed at top dead center and its compression stroke.

5. Set timing belt tensioner.
 - 1) Using a press, slowly press in the push rod.
 - 2) Align the holes of the push rod and housing pass a set pin through the holes to keep the setting position of the push rod.
 - 3) Release the press.
6. Install the timing belt tensioner.
 - 1) Temporarily install the tensioner with the 2bolts.
 - 2) Alternately tighten the 2bolts.

Tightening torque
20 ~ 27N.m (200 ~ 270kgf.cm, 14 ~ 20lbf.ft)

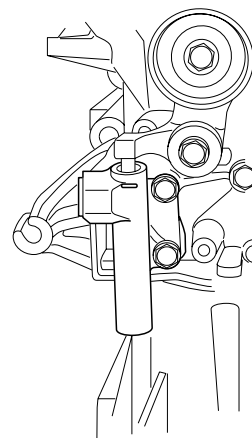

LUIF025A

7. Install the timing belt.

- 1) Remove any oil or water on the sprockets, and keep them clean.
- 2) Install the timing belt in this order.
Crankshaft sprocket(A) Idler pulley(B)
Camshaft sprocket LH side(C) Water pump pulley(D)
Camshaft sprocket RH side(E)
Tensioner pulley(F).

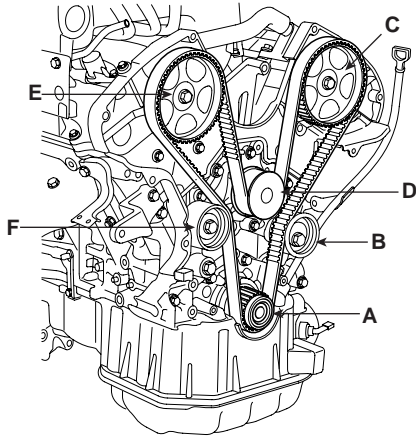

LUIF026A

8. Remove the set pin(A) from the tensioner.

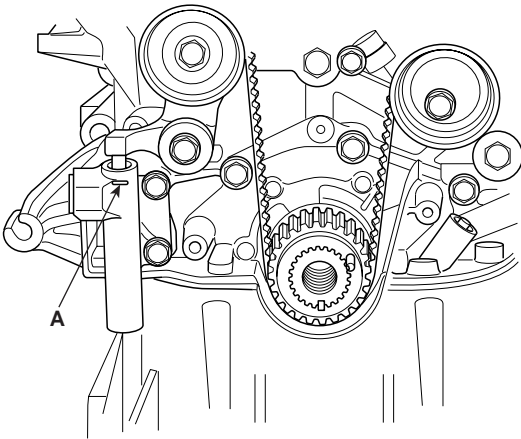

LUIF027A

9. Timing belt tensioner checking.

- 1) Rotate the crankshaft 2 turns clockwise and measure the projected length of the auto tensioner at TDC(#1 compression stroke) after 5 minutes.
- 2) The projected length should be 7 ~ 9mm (0.27 ~ 0.31in.)

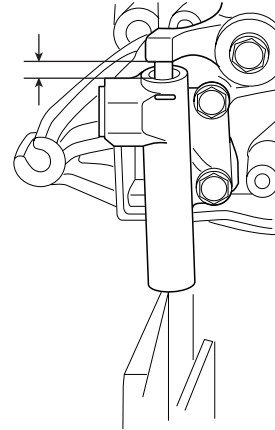

LUIF028A

10. Install the engine support bracket(A).

Tightening torque

B : 60 ~ 70N.m (600 ~ 700kgf.cm, 43 ~ 51lb.ft)

C : 15 ~ 22N.m (150 ~ 220kgf.cm, 11 ~ 16lb.ft)

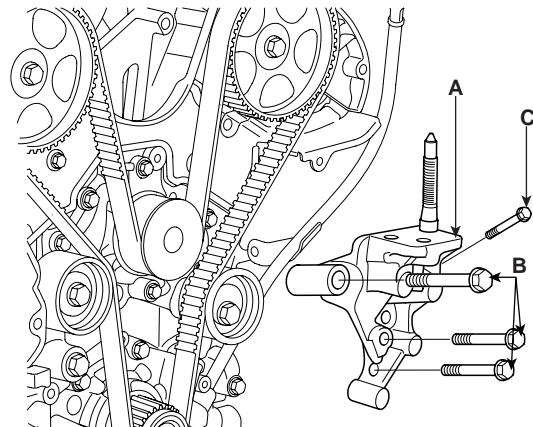

LUIF029A

11. Install the timing belt lower cover(A) with 4bolts(B).

Tightening torque

Timing belt cover bolt

10 ~ 12N.m (100 ~120kgf.cm, 7 ~ 9lbf.ft)

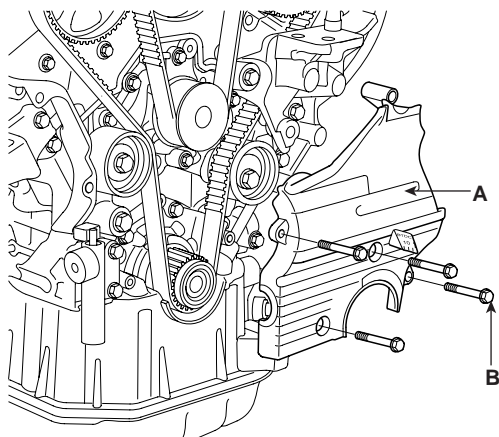

LUIF030A

12. Install the drive belt idler pulley(A).

Tightening torque

Idler pulley bolt

35 ~ 55N.m (350 ~ 550kgf.cm, 25 ~ 40lbf.ft)

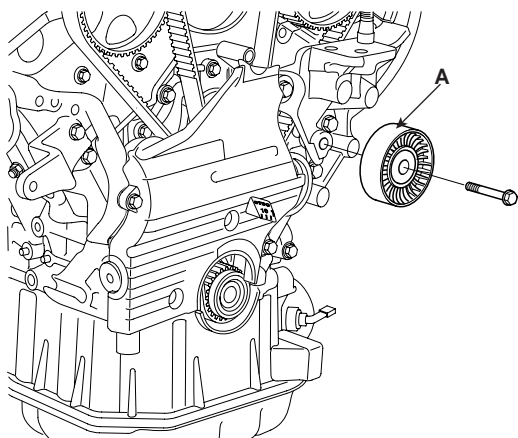

LUIF031A

13. Install the crankshaft pulley(A).

Make sure that crankshaft sprocket pin fits the small hole in the pulley.

Tightening torque

Crankshaft pulley bolt

180 ~ 190N.m (1800 ~ 1900kgf.cm, 130 ~ 138lbf.ft)

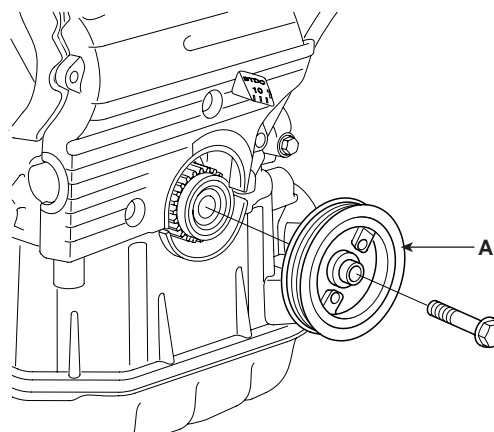

LUIF032A

14. Install the timing belt upper cover(A) with 7bolts(B).

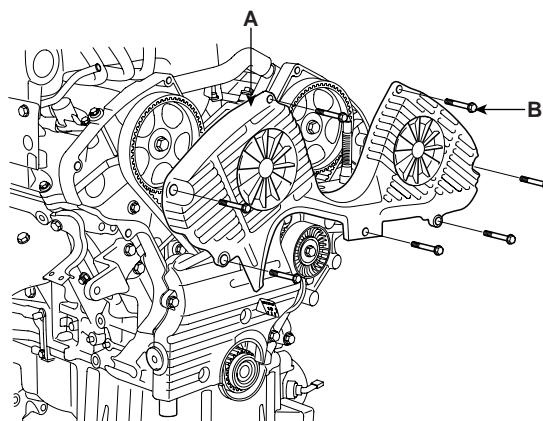

LUIF033A

15. Install the power steering pump. (See ST group - power steering pump)

16. Install the drive belt tensioner(B) and drive belt(A).

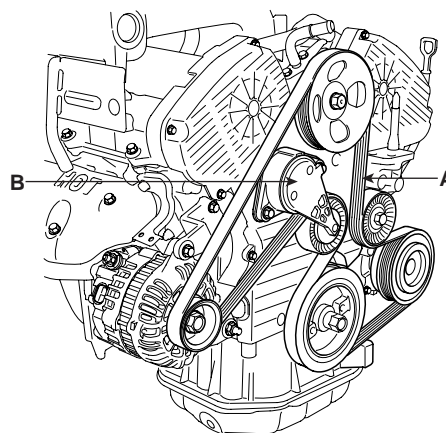

LUIF034A

17. Install the engine mount bracket.
Install engine mount bracket with 2nuts and 2bolt.

Tightening torque

60 ~ 80N.m (600 ~ 800kgf.cm, 44 ~ 59lbf.ft)

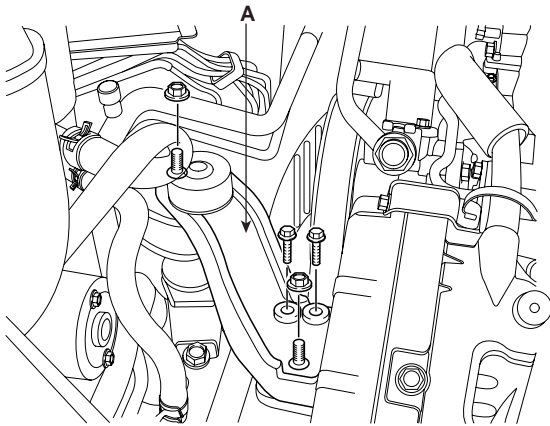

LUIF035A

18. Install RH side cover(A) with 2bolts(B).

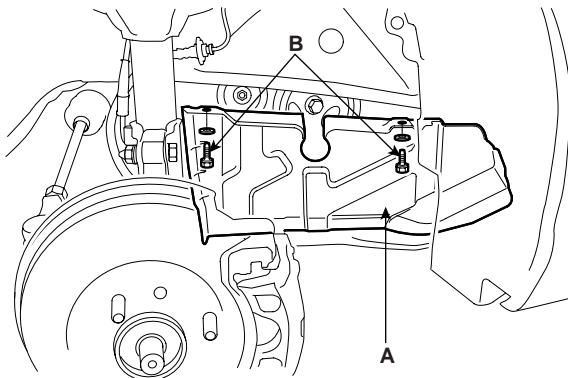

LUIF036A

19. Install RH front wheel.
20. Install engine cover.

CYLINDER HEAD ASSEMBLY

COMPONENTS EBB20DC0

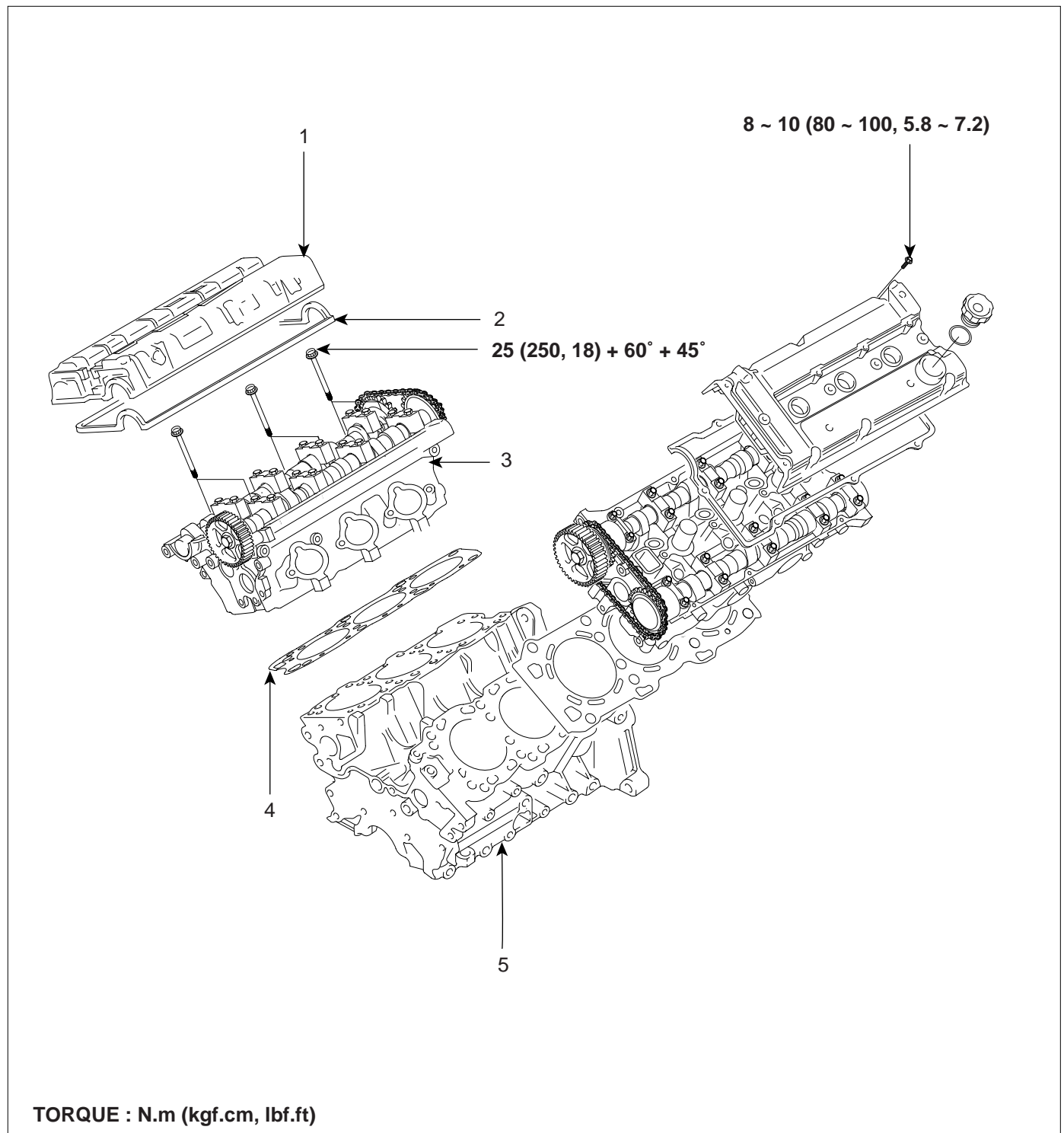

- 1. Cylinder head cover
- 2. Gasket
- 3. Cylinder head

- 4. Cylinder head gasket
- 5. Cylinder block

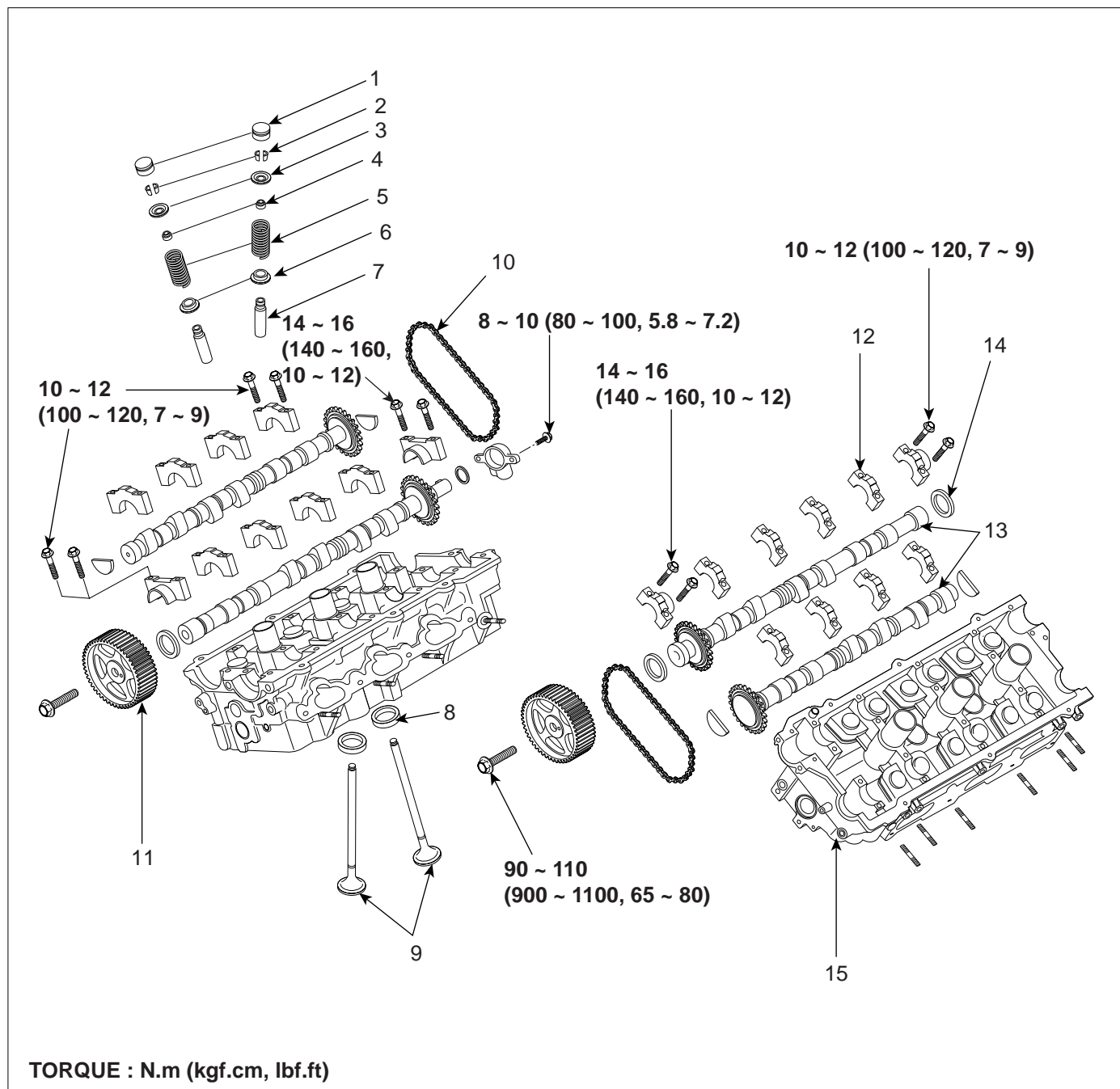

- | | |
|-------------------------------|--------------------------|
| 1. HLA | 9. Valve |
| 2. Valve spring retainer lock | 10. Timing chain |
| 3. Valve spring retainer | 11. Camshaft sprocket |
| 4. Valve stem seal | 12. Camshaft bearing cap |
| 5. Valve spring | 13. Camshaft |
| 6. Valve spring seat | 14. Oil seal |
| 7. Valve guide | 15. Cylinder head |
| 8. Valve seat | |

REMOVAL EBF01FC1

Engine removal is not required for this procedure.

 CAUTION

- Use fender covers to avoid damaging painted surfaces.
- To avoid damaging the cylinder head, wait until the engine coolant temperature drops below normal temperature before removing it.
- When handling a metal gasket, take care not to fold the gasket or damage the contact surface of the gasket.
- To avoid damage, unplug the wiring connectors carefully while holding the connector portion.

 NOTE

- Mark all wiring and hoses to avoid misconnection.
- Inspect the timing belt before removing the cylinder head.
- Turn the crankshaft pulley so that the No. 1 piston is at top dead center. (See page EMB - 14).

1. Remove the air duct(A).

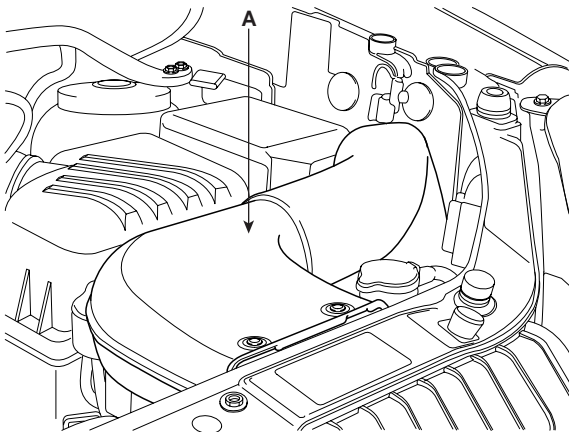

LUIF039A

2. Remove the cowl grill and wiper motor.(Refer to BE Gr.)
3. Remove the strut bar.

4. Disconnect the negative terminal from the battery.

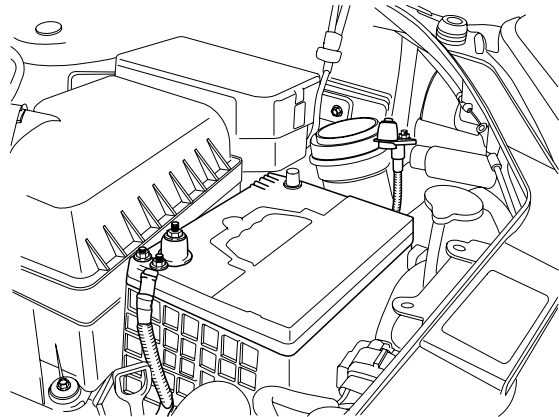

LUIF040A

5. Drain the engine coolant. (See page EMB - 70) Remove the radiator cap to speed draining.
6. Remove the engine cover.
7. Remove the intake air hose and air cleaner assembly.
 - 1) Disconnect the AFS connector(A).
 - 2) Disconnect the breather hose(B) from air cleaner hose.
 - 3) Remove the intake air hose and air cleaner assembly(C).

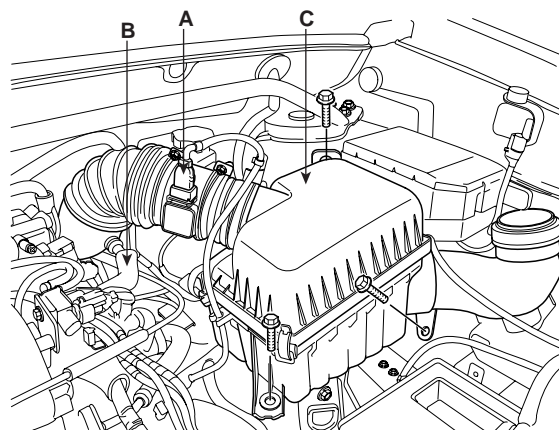

LUIF041A

8. Remove the coolant reservoir tank(A).

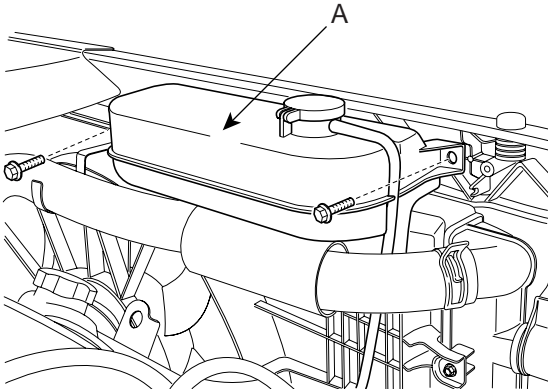

LUIF231A

9. Remove the upper radiator hose(A) and lower radiator hose(B).

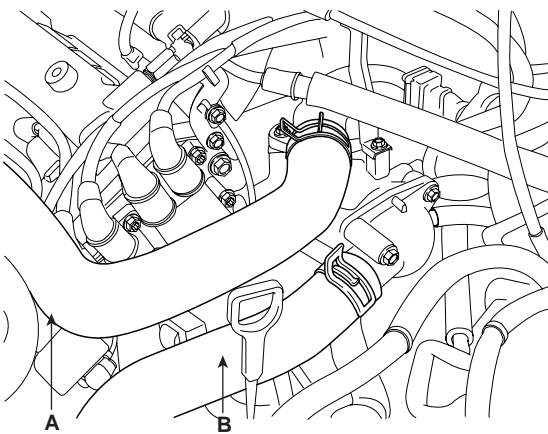

LUIF042A

10. Remove the heater hoses(A) and throttle body heater hose(B).

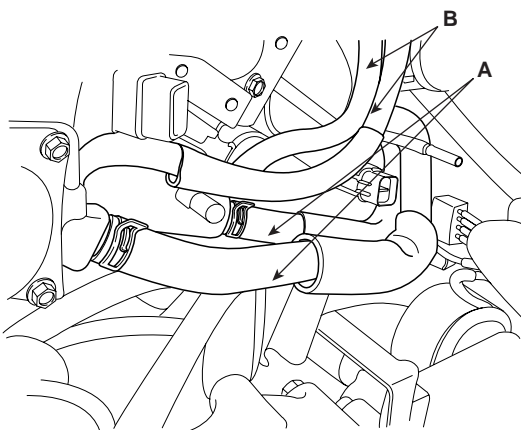

LUIF043A

11. Remove the engine wire harness connectors and wire harness clamps from the cylinder head and the intake manifold.

- 1) TPS(Throttle Position Sensor) connector(A).
- 2) ISA(Idle Speed Actuator) connector(B).
- 3) PCSV(Purge Control Solenoid Valve) connector(C).
- 4) VIS actuator connector(D).
- 5) Injector connector(E).
- 6) Knock sensor connectors(F).
- 7) CMP(Camshaft Position Sensor) connector(G).
- 8) Oxygen sensor(rear 1st) connector(H).
- 9) PCSV(Purge Control Solenoid Valve) hose(I).

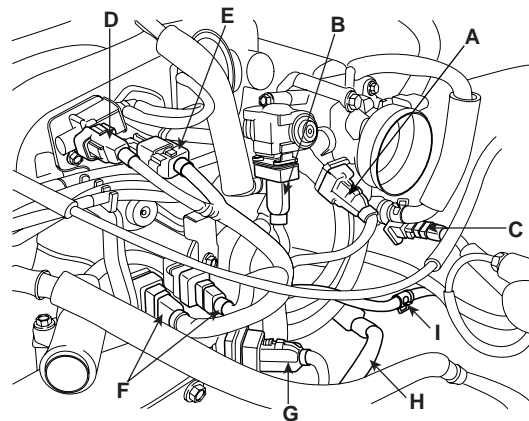

LUIF044A

- 10) ECT(Engine Coolant Temperature) sensor connector(A).
- 11) Ignition coil connector(B).
- 12) Crankshaft position sensor connector(C).
- 13) Oxygen sensor(front 2nd) connector(D).

CYLINDER HEAD ASSEMBLY

14) Ground cable(E).

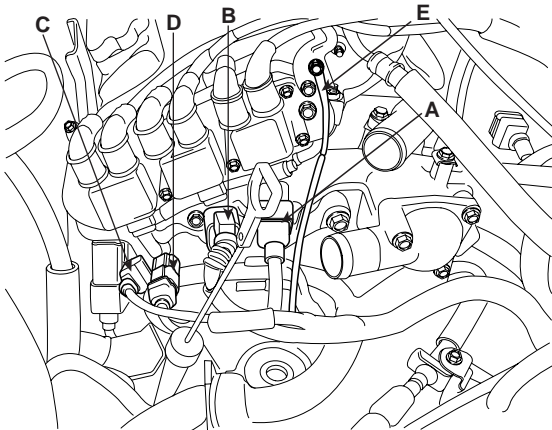

LUIF045A

20) Power steering pump switch(D).

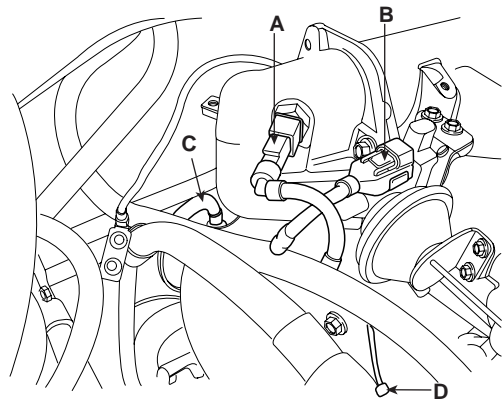

LUIF048A

15) Three fuel injector connectors(A).

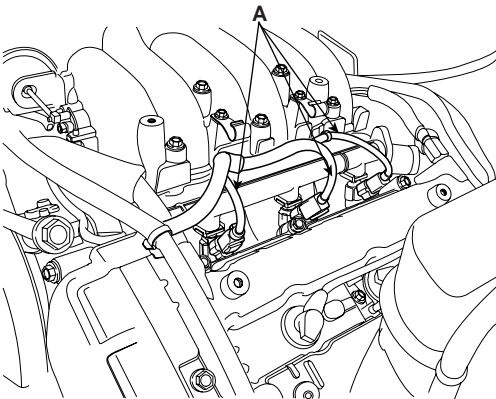

LUIF046A

21) Oxygen sensor(front 1st) connetor(A).

22) Air conditioner compressure switch connetor(B).

23) Oill pressure sensor connector(C).

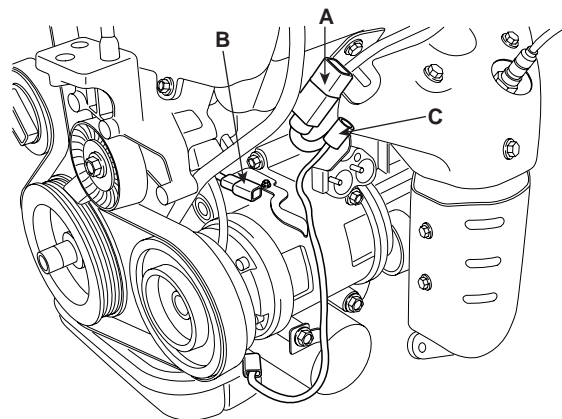

LUIF050A

16) Disconnect ground cable(A) from the cowl panel.

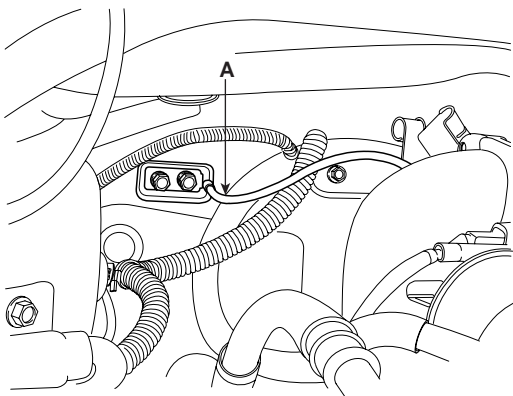

LUIF047A

12. Remove the fuel inlet hose(A) from delivery pipe.

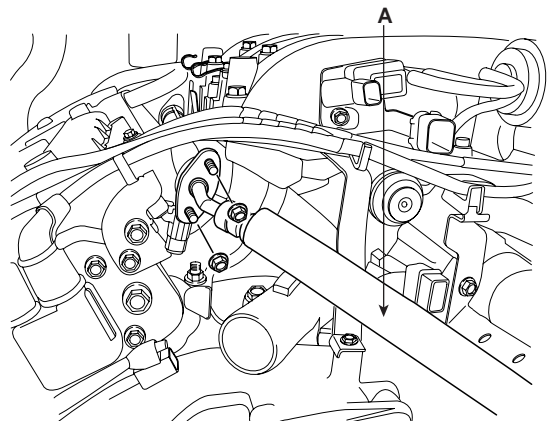

LUIF049A

17) IAT(Intake Air Temperature) sensor connector(A).

18) VIS actuator connector(B).

19) Oxygen sensor(rear 2nd) connector(C).

EMB -26

ENGINE (G6BA - GASOLINE 2.7)

13. Remove the brake booster vacuum hose(A).

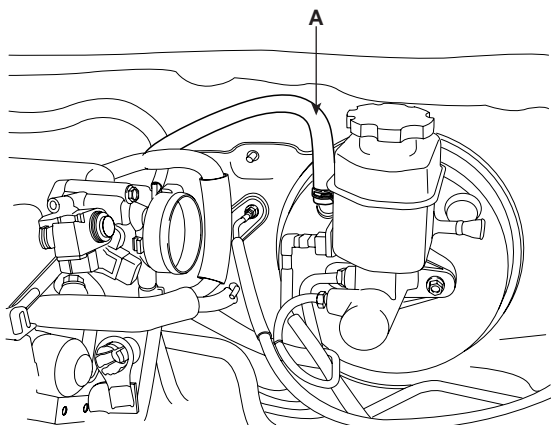

LUIF051A

14. Remove the accelerator cable by loosening the lock-nut, then slip the cable end out of the throttle linkage.

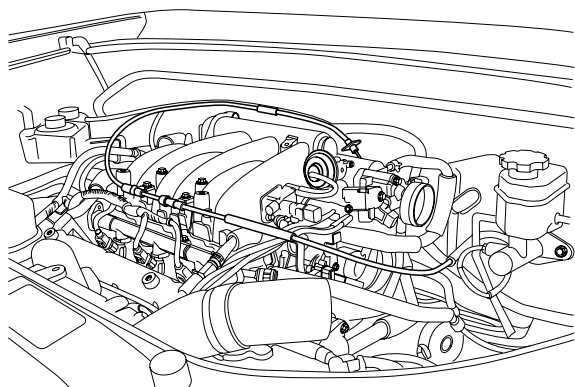

LUIF052A

15. Remove the PCV hose(A).

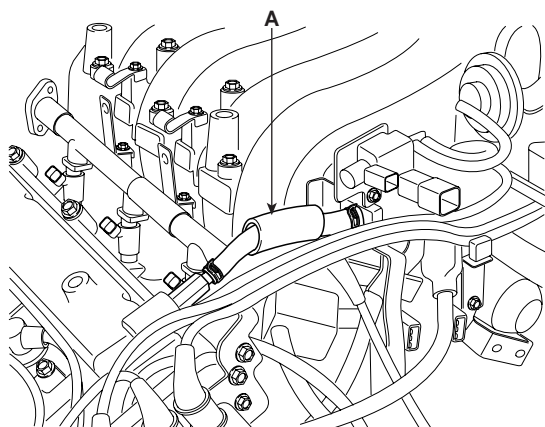

LUIF053A

16. Remove the intake manifold. (See page EMB - 88)

17. Remove the power steering pump. (See ST group - power steering pump).

18. Remove the exhaust manifold. (See page EMB - 90)

19. Remove the timing belt. (See page EMB - 14)

20. Remove the spark plug cable. (See EE group - ignition)

21. Remove the cylinder head covers(A).

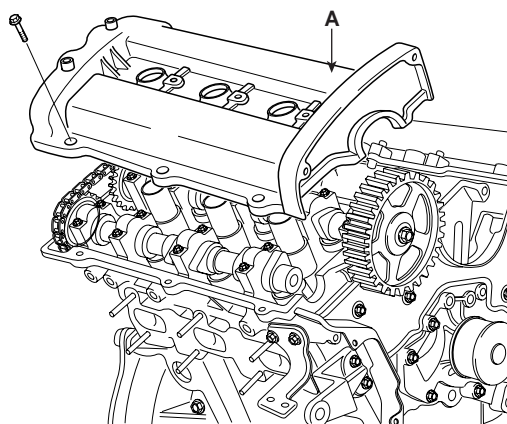

LUIF054A

22. Remove the camshaft sprocket.

23. Remove the camshaft bearing caps(A).

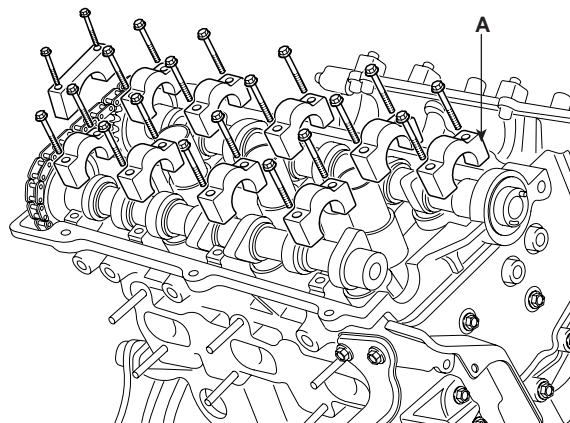

LUIF055A

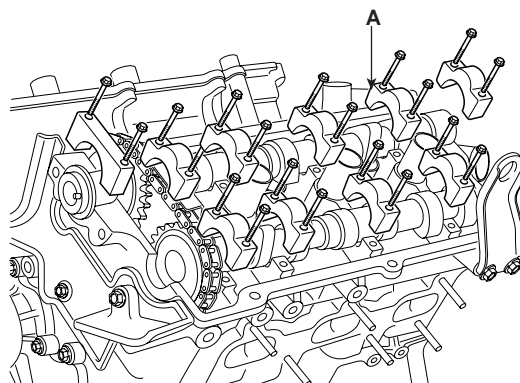

LUIF056A

CYLINDER HEAD ASSEMBLY

EMB -27

24. Remove the camshafts(A).

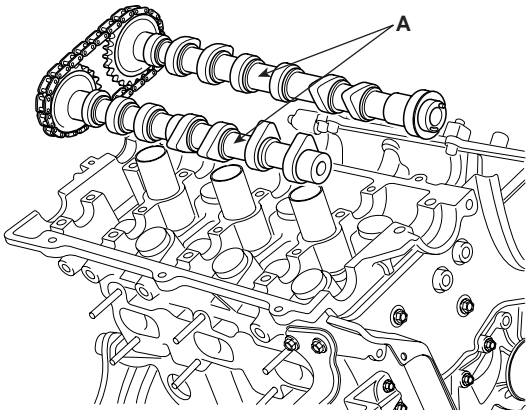

LUIF057A

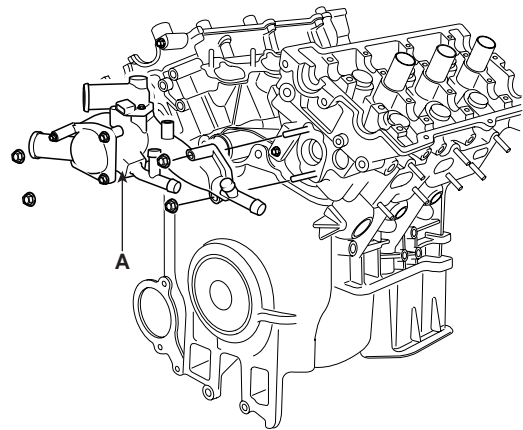

LUIF060A

27. Remove the cylinder head bolts, then remove the cylinder heads.

- 1) Uniformly loosen and remove the 8 cylinder head bolts on each cylinder head in several passes and in the sequence shown, then repeat for the other side, as shown. Remove the 16 cylinder head bolts and plate washer.

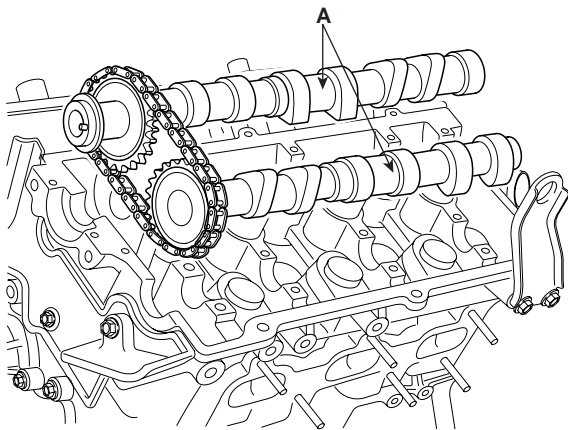

LUIF058A

25. Remove the timing belt rear cover(A).

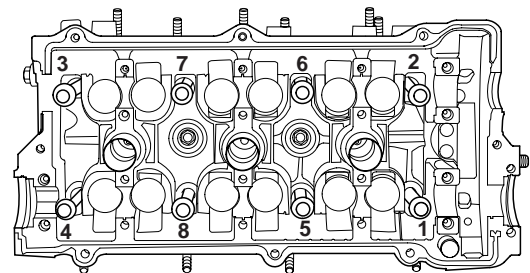

LUIF059A

26. Remove the water temperature control assembly(A) and water pipe.

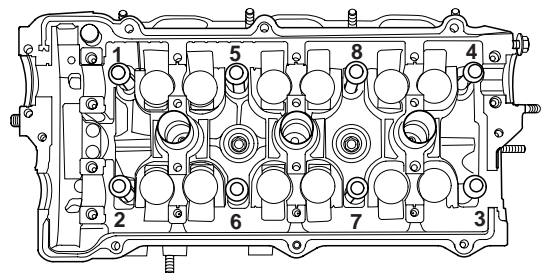

LUIF061A

CAUTION

Head warpage or cracking could result from removing bolts in an incorrect order.

- 2) Lift the cylinder head from the dowels on the cylinder block and place the cylinder head on wooden blocks on a bench.

CAUTION

Be careful not to damage the contact surfaces of the cylinder head and cylinder block.

DISASSEMBLY E0A2B7FC

NOTE

Identify HLA(Hydraulic Lash Adjuster), valves, valve springs as they are removed so that each item can be reinstalled in its original position.

1. Remove HLAs(A).

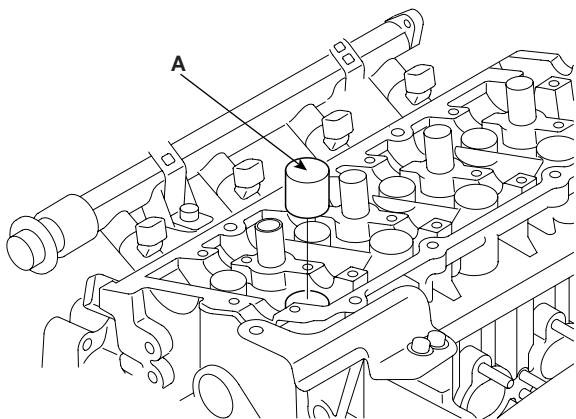

LUIF062A

2. Remove valves.

- 1) Using SST(09222-28000, 09222-28100), compress the valve spring and remove retainer lock.

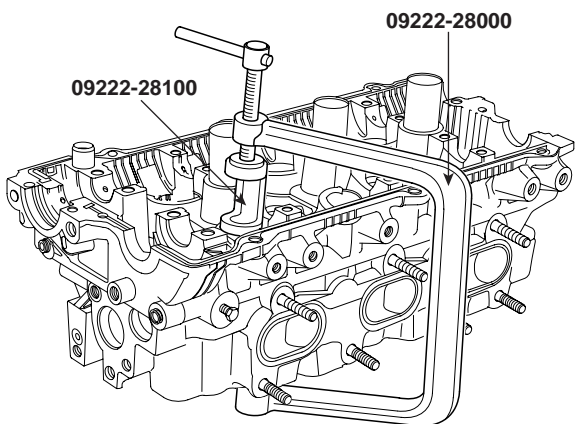

LUIF063A

- 2) Remove the spring retainer.
- 3) Remove the valve spring.
- 4) Remove the valve.
- 5) Using needle-nose pliers, remove the oil seal.
- 6) Using a magnetic finger, remove the spring seat.

INSPECTION EA7C4FD7

CLENGING

1. Clean top surfaces of pistons and cylinder block.
 - 1) Turn the crankshaft, and bring each piston to top dead center(TDC). Using a gasket scraper, remove all the carbon from the piston top surface.
 - 2) Using a gasket scraper, remove all the gasket material from the cylinder block surface.
 - 3) Using compressed air, blow carbon and oil from the bolt holes.
2. Remove gasket material. Using a gasket scraper, remove all the gasket material from the cylinder block contact surface.

CAUTION

Be careful not to scratch the cylinder block contact surface.

3. Clean combustion chambers. Using a wire brush, remove all the carbon from the combustion chambers.

CAUTION

Be careful not to scratch the cylinder block contact surface.

4. Clean cylinder heads. Using a soft brush and solvent. thoroughly clean the cylinder head.
5. Clean valves.
 - 1) Using a gasket scraper, chip off any carbon from the valve head.
 - 2) Using a wire brush thoroughly clean the valve.

CYLINDER HEAD

1. Inspect for flatness.
Using a precision straight edge and feeler gauge, measure the surface the contacting the cylinder block for warpage.

Flatness of cylinder head gasket surface

Standard : Less than 0.03mm(0.0012 in.)

Limit : 0.05mm (0.0020 in.)

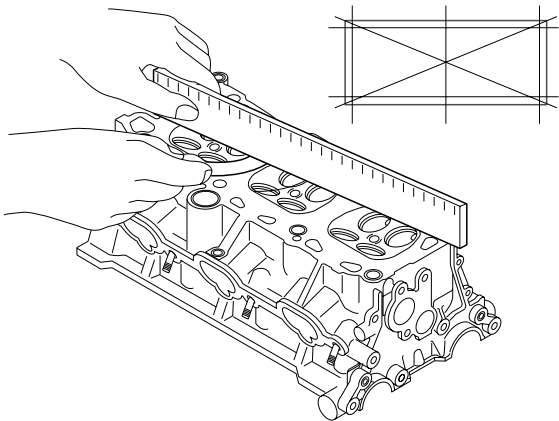

LUIF064A

2. Inspect for cracks.
Check the combustion chamber, intake ports, exhaust ports and cylinder block surface for cracks. If cracked, replace the cylinder head.

VALVE AND VALVE SPRING

1. Inspect valve stems and valve guides.
 - 1) Using a caliper gauge, measure the inside diameter of the valve guide.
Valve guide inside.

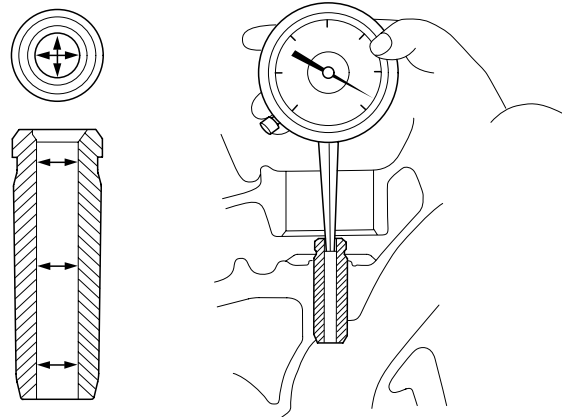

LUIF065A

- 2) Using a micrometer, measure the diameter of the valve stem.

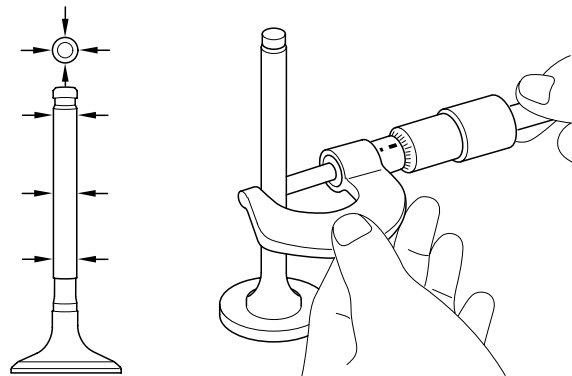

LUIF066A

- 3) Subtract the valve stem diameter measurement from the valve guide inside diameter measurement.
Valve stem-to-guide clearance

[Standard]

Intake : 0.02 ~ 0.05mm (0.0008 ~ 0.0020in.)

Exhaust : 0.030 ~ 0.065mm (0.0012 ~ 0.0026in.)

[Limit]

Intake : 0.1mm (0.0040in.)

Exhaust : 0.13mm (0.0051in.)

If the clearance is greater than maximum, replace the valve and valve guide.

2. Inspect valves.

- 1) Check the valve is ground to the correct valve face angle.
- 2) Check that the surface of the valve for wear. If the valve face is worn, replace the valve.
- 3) Check the valve head margin thickness. If the margin thickness is less than minimum, replace the valve.

Margin

[Standard]

Intake : 1.0mm (0.0394in.)

Exhaust : 1.3mm (0.0512in.)

[Limit]

Intake : 0.5mm (0.0197in.)

Exhaust : 0.8mm (0.0315in.)

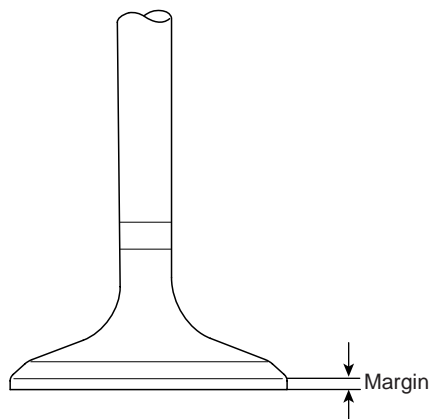

LUIF067A

3. Inspect valve seats

Check the valve seat for evidence of overheating and improper contact with the valve face.

Replace the seat if necessary.

Before reconditioning the seat, check the valve guide for wear. If the valve guide is worn, replace it, then recondition the seat. Recondition the valve seat with a valve seat grinder or cutter. The valve seat contact width should be within specifications and centered on the valve face.

4. Inspect valve springs.

- 1) Using a steel square, measure the out-of-square of the valve spring.
- 2) Using a vernier calipers, measure the free length of the valve spring.

Valve spring

[Standard]

Free height : 42.5mm (1.6732in.)

Load : 21kg/35mm (48.4kg/1.378mm)

[Limit]

Free height : -1.0mm (-0.0394 in.)

Out-of-square : 3°

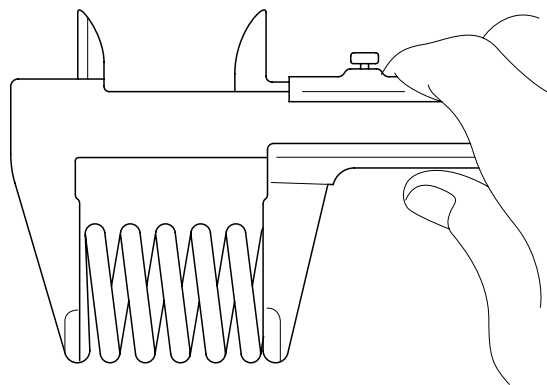

LUIF068A

If the free length is not as specified, replace the valve spring.

CAMSHAFT

1. Inspect cam lobes.
Using a micrometer, measure the cam lobe height.

Cam height

[Standard value]

Intake : 43.95 ~ 44.15mm (1.7303 ~ 1.7382in.)

Exhaust : 43.95 ~ 44.15mm (1.7303 ~ 1.7382in.)

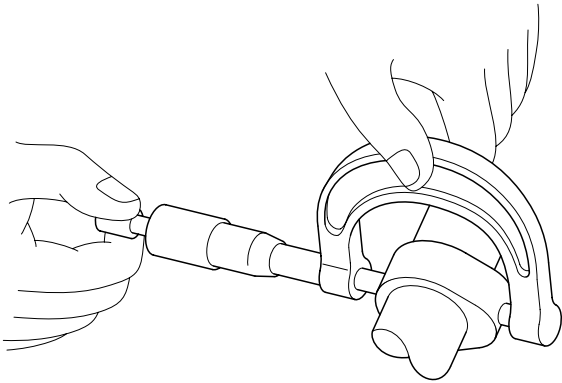

LUIF069A

If the cam lobe height is less than minimum, replace the camshaft.

2. Inspect cam journals.
Using a micrometer, measure the journal diameter.

Journal diameter

Standard value

25.964 ~ 25.980mm (1.0222 ~ 1.0228in.)

If the journal diameter is not as specified, check the oil clearance.

3. Inspect camshaft bearings.
Check that bearing for flaking and scoring. If the bearings are damaged, replace the bearing caps and cylinder head as a set.
4. Inspect camshaft journal oil clearance.
 - 1) Clean the bearing caps and camshaft journals.
 - 2) Place the camshafts on the cylinder head.
 - 3) Lay a strip of plastigage across each of the camshaft journal.

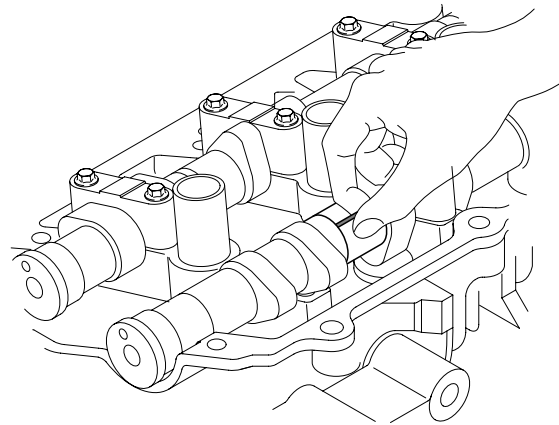

LUIF070A

- 4) Install the bearing caps. (See page EMB - 36)

CAUTION

Do not turn the camshaft.

- 5) Remove the bearing caps.
- 6) Measure the plastigage at its widest point.

Bearing oil clearance

Standard value : 0.02 ~ 0.061mm (0.0008 ~ 0.0024in.)

Limit : 0.1mm (0.0039in.)

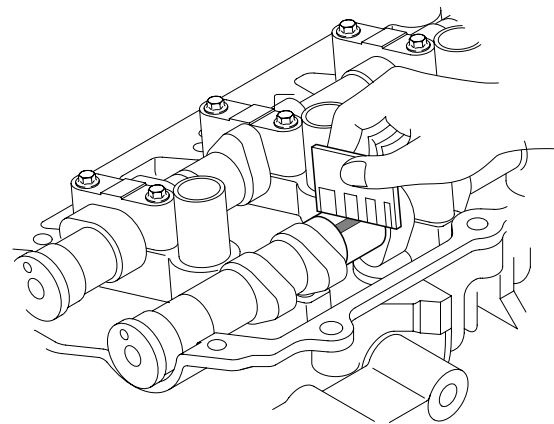

LUIF071A

If the oil clearance is greater than maximum, replace the camshaft. If necessary, replace the bearing caps and cylinder head as a set.

- 7) Completely remove the plastigage.
- 8) Remove the camshafts.

5. Inspect camshaft end play.
 - 1) Install the camshafts. (See page EMB - 36).
 - 2) Using a dial indicator, measure the end play while moving the camshaft back and forth.

Camshaft end play

Standard value : 0.1 ~ 0.15mm (0.004 ~ 0.0059in.)

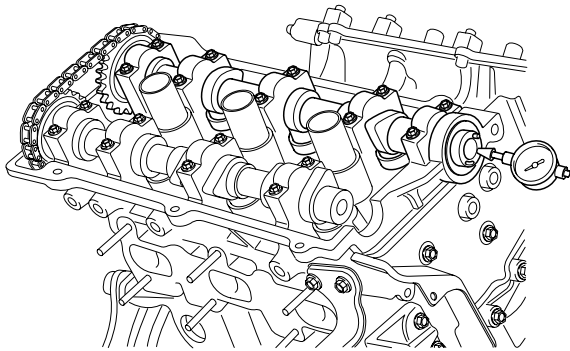

LUIF072A

If the end play is greater than maximum, replace the camshaft. If necessary, replace the bearing caps and cylinder head as a set.

- 3) Remove the camshafts.

REPLACEMENT E2DBA5AA

VALVE GUIDE

1. Using the SST(09221-3F100A), withdraw the old valve guide toward the bottom of cylinder head.

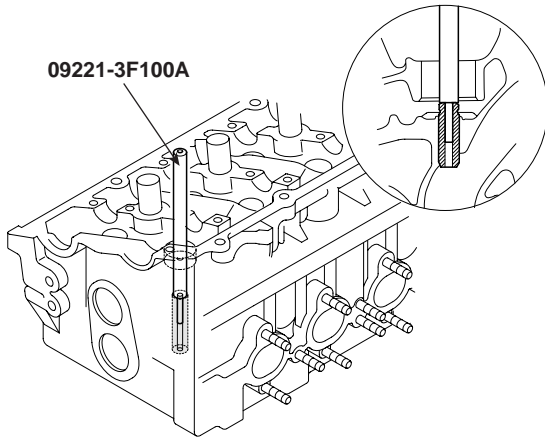

LUIF073A

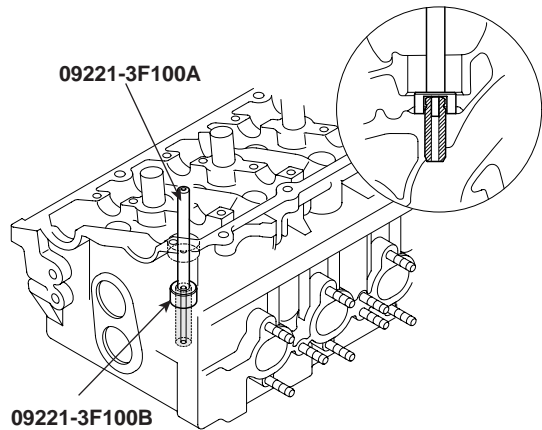

LUIF074A

2. Recondition the valve guide hole so that it can match the newly press-fitted oversize valve guide.
3. Using the SST(09221-3F100A/B), press-fit the valve guide. The valve guide must be press-fitted from the upper side of the cylinder head. Keep in mind that the intake and exhaust valve guides are different in length.

4. After the valve guide is press-fitted, insert a new valve and check for proper stem -to-guide clearance.
5. After the valve guide is replaced, check that the valve is seated properly. Recondition the valve seats as necessary.

Over size mm(in.)	Size mark	Oversize valve guide hole size mm(in.)
0.05 (0.002)	5	11.05 ~ 11.068 (0.4350 ~ 0.4357)
0.25 (0.010)	25	11.25 ~ 11.268 (0.4429 ~ 0.4436)
0.50 (0.020)	50	11.50 ~ 11.518 (0.4528 ~ 0.4535)

Valve guide length

Intake : 39mm (1.535in.)

Exhaust : 43mm (1.693in.)

REASSEMBLY

ED0E3ADE

 **NOTE**

Thoroughly clean all parts to be assembled.
Before installing the parts, apply fresh engine oil to all sliding and rotating surfaces.
Replace oil seals with new ones.

1. Install valves.

- 1) Install the spring seats.
- 2) Using SST(09222-22001), push in a new oil seal.

 **NOTE**

Do not reuse old valve stem seals.
Incorrect installation of the seal could result in oil leakage past the valve guides.

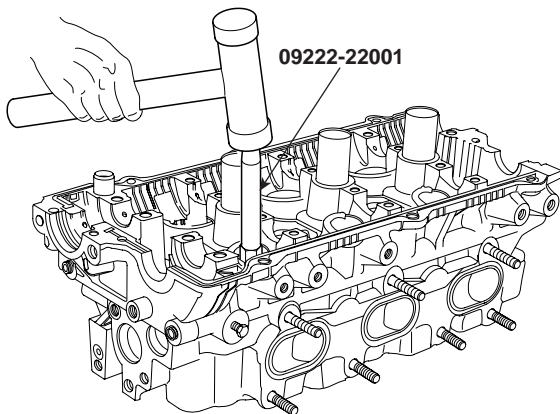

LUIF075A

3) Install the valve, valve spring and spring retainer.

 **NOTE**

Place valve springs so that the side coated with enamel faces toward the valve spring retainer and then installs the retainer.

- 4) Using the SST(09222-28000, 09222-28100), compress the spring and install the retainer locks. After installing the valves, ensure that the retainer locks are correctly in place before releasing the valve spring compressor.

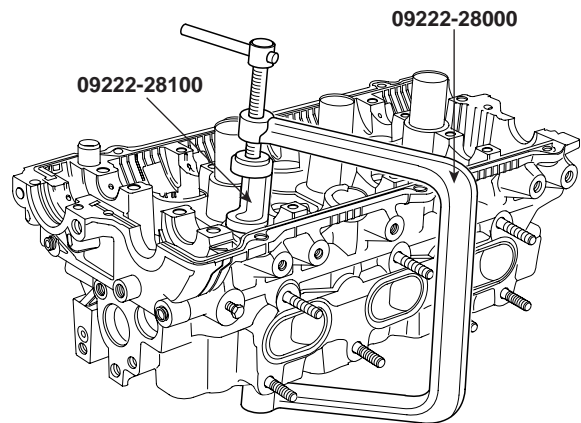

LUIF076A

- 5) Lightly tap the end of each valve stem two or three times with the wooden handle of a hammer to ensure proper seating of the valve and retainer lock.

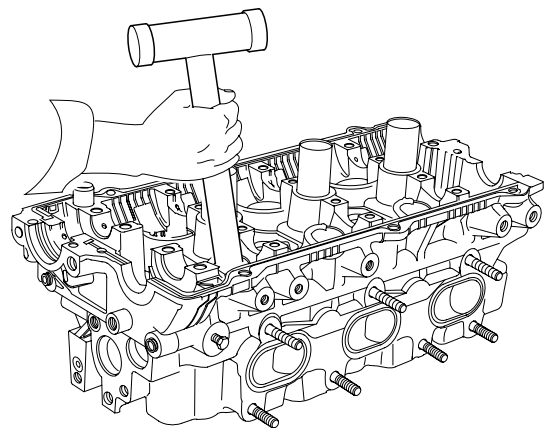

LUIF077A

2. Install HLAs.

Check that the HLA rotates smoothly by hand.

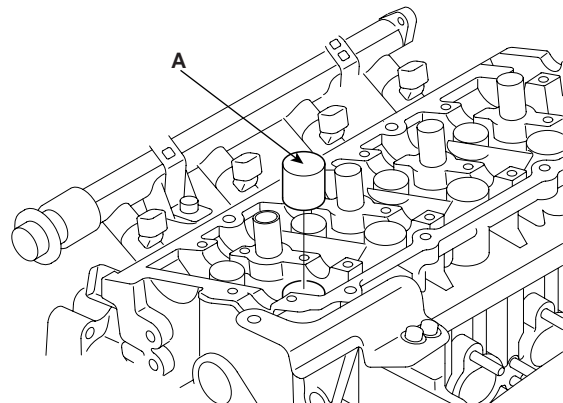

LUIF078A

INSTALLATION E73CA5E8

 **NOTE**

- Thoroughly clean all parts to be assembled.
- Always use a new head and manifold gasket.
- The cylinder head gasket is a metal gasket. Take care not to bend it.
- Rotate the crankshaft, set the No.1 piston at TDC. (See page EMB - 14).

1. Install the cylinder head gaskets on the cylinder block.

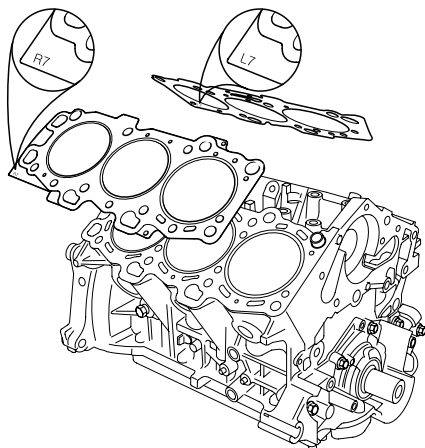

LUIF079A

 **NOTE**

Be careful of the installation direction.

2. Place the cylinder head quietly in order not to damage the gasket with the bottom part of the end.
3. Install cylinder head bolts.

Tightening torque

25N.m (250kgf.cm, 18lbf.ft) + 60° + 45°

- 1) Apply a light coat of engine oil on the threads and under the heads of the cylinder head bolts.
- 2) Install the plate washer to the cylinder head bolt.
- 3) Install the uniformly tighten the cylinder head bolts on each cylinder head in several passes and in the sequence shown, then repeat for the other side, as shown.

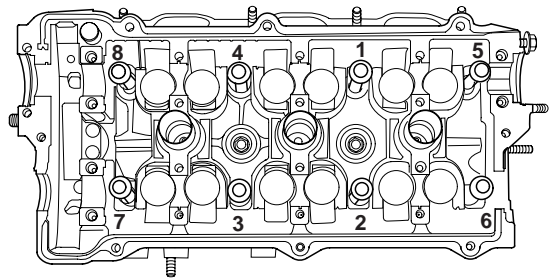
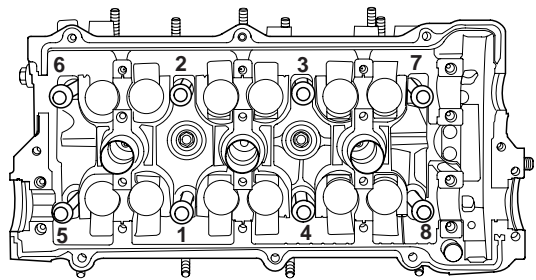

LUIF080A

If only of the cylinder head bolts dose not meet the torque specification, repeat the cylinder head bolt.

Torque : 25N.m (250kgf.cm, 18lbf.ft)

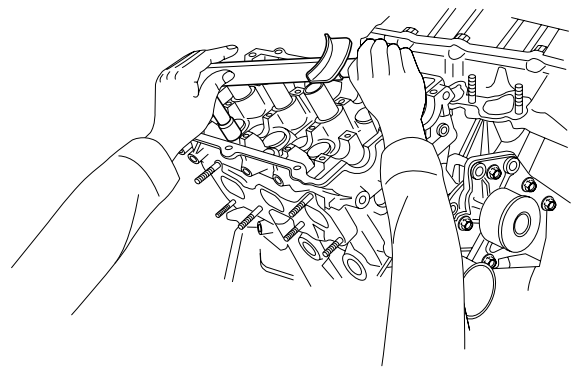

LUIF081A

- 4) Retighten the cylinder head bolts by 60° in the numerical order shown.
- 5) Retighten the cylinder head bolts by 45° in the numerical order shown.

EMB -36

ENGINE (G6BA - GASOLINE 2.7)

4. Install the water pipe and water temperature control assembly(A).

Tightening torque

Water temperature control

15 ~ 20N.m (150 ~ 200kgf.cm, 11 ~ 14lbf.ft)

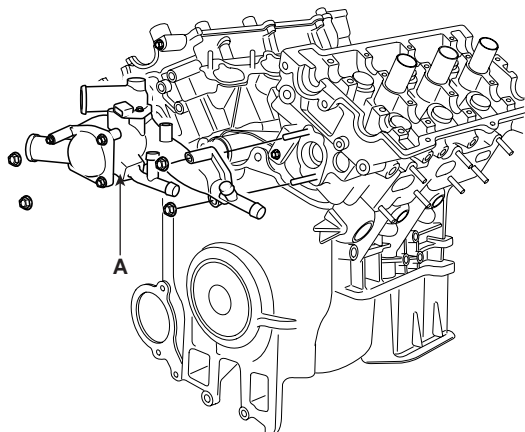

LUIF082A

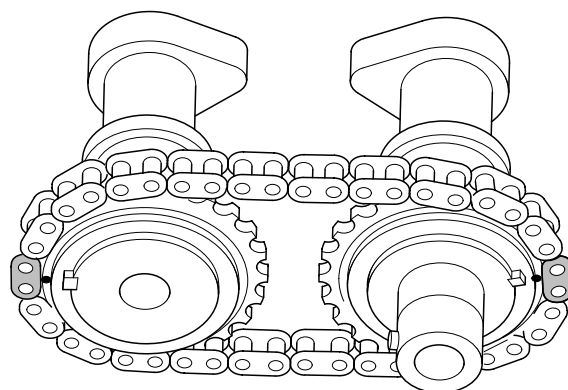

LUIF084A

- 2) Install the camshaft(A).

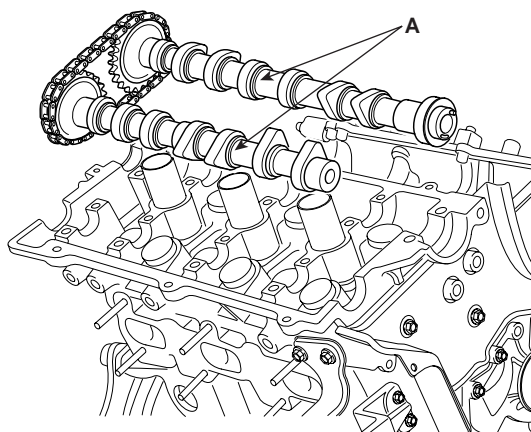

LUIF085A

5. Install the timing belt rear cover(A).

Tightening torque

Timing belt rear cover

10 ~ 12N.m (100 ~ 120kgf.cm, 7 ~ 9lbf.ft)

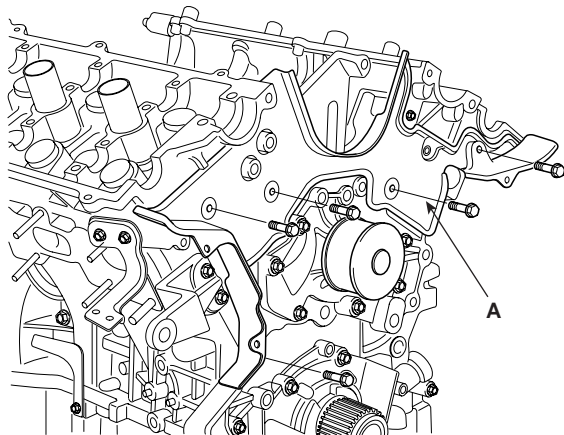

LUIF083A

- 3) Install the camshaft bearing caps(A).

Tightening torque

M6(38mm) : 10 ~ 12N.m

(100 ~ 120kgf.cm, 7 ~ 9lbf.ft)(Mark7)

M6(50mm) : 14 ~ 16N.m

(140 ~ 160kgf.cm, 10 ~ 12lbf.ft)(Mark10)

6. Install the camshafts.

- 1) Align the camshaft timing chain with the intake timing chain sprocket and exhaust timing chain sprocket as shown.

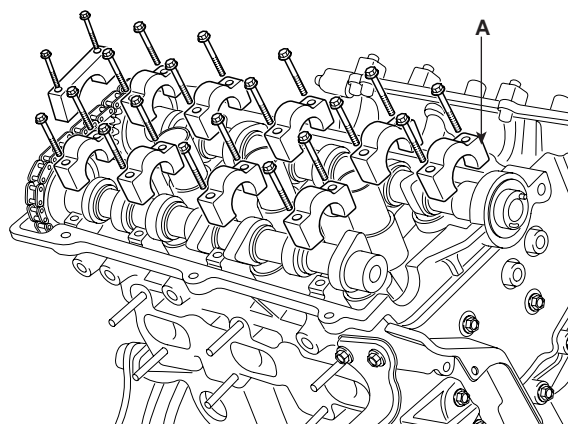

LUIF055A

NOTE

- Apply new engine oil to the thrust portion and journal of the camshafts.
- Apply a light coat of engine oil on the threads and under the heads of the bearing cap bolts.

7. Using the SST (09214-21000), install the camshaft bearing oil seal.

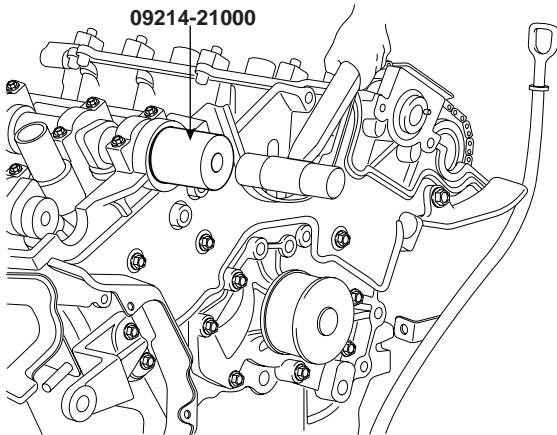

LUIF087A

8. Install the camshaft sprocket.
- 1) Temporarily install the camshaft sprocket bolts.
 - 2) Hold the hexagonal head wrench portion of the camshaft with a wrench, and tighten the camshaft sprocket bolts.

Tightening torque

Camshaft sprocket bolt
90 ~ 110N.m (900 ~ 1100kgf.cm, 65 ~ 80lb.ft)

9. Install semi-circular packing.
10. Install the cylinder head cover.
- 1) Install the cylinder head cover gasket(A) in the groove of the cylinder head cover(B).

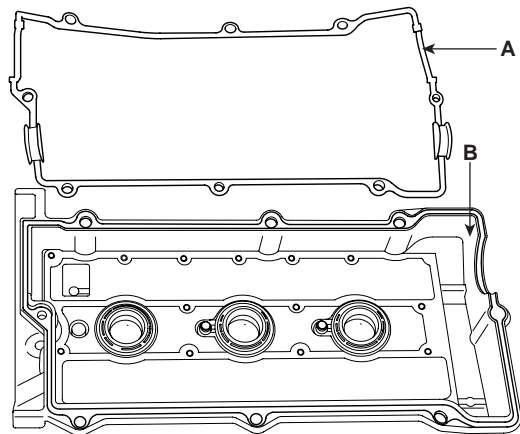

LUIF088A

NOTE

- Before installing the head cover gasket, thoroughly clean the head cover gasket and the groove.
- When installing, make sure the head cover gasket is seated securely in the corners of the recesses with no gap.

- 2) Apply liquid gasket to the head cover gasket at the corners of the recess.

NOTE

- Use liquid gasket, loctite No.5699.
- Check that the mating surfaces are clean and dry before applying liquid gasket.
- After assembly, wait at least 30 minutes before filling the engine with oil.

- 3) Install the cylinder head covers(A) with the 16bolts. Uniformly tighten the bolts in several passes.

Tightening torque

8 ~ 10N.m (80 ~ 100kgf.cm, 6 ~ 7.4lb.ft)

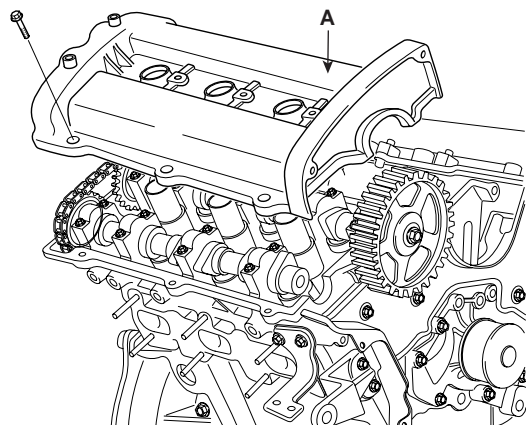

LUIF089A

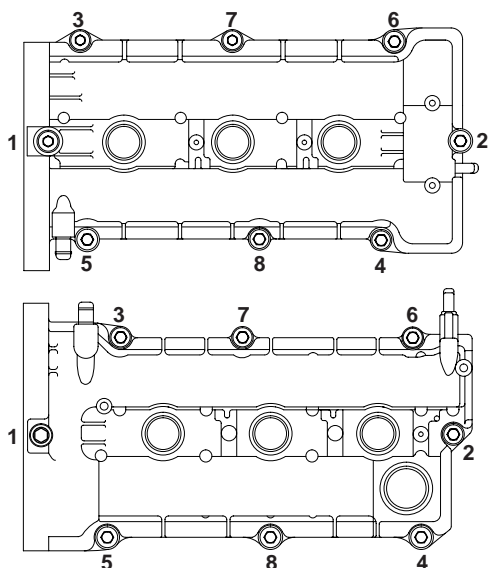

LUIF090A

11. Install the spark plug cable. (See EE group - ignition)
12. Install the timing belt. (See page EMB - 17).
13. Install the exhaust manifold. (See page EMB - 92)
14. Install the power steering pump. (See ST group - power steering pump)
15. Install the intake manifold. (See page EMB- 91)
16. Install the PCV hose(A).

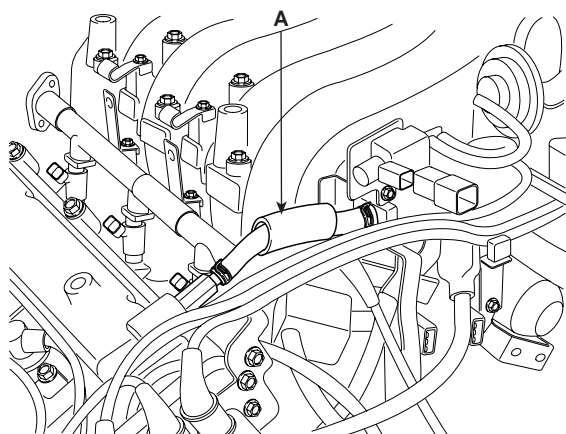

LUIF091A

17. Install the accelerator cable.

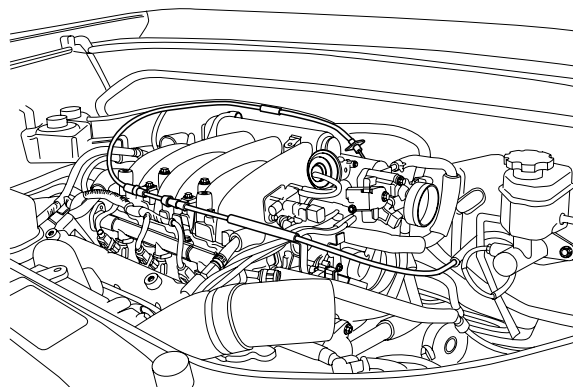

LUIF092A

18. Install the brake booster vacuum hose(A).

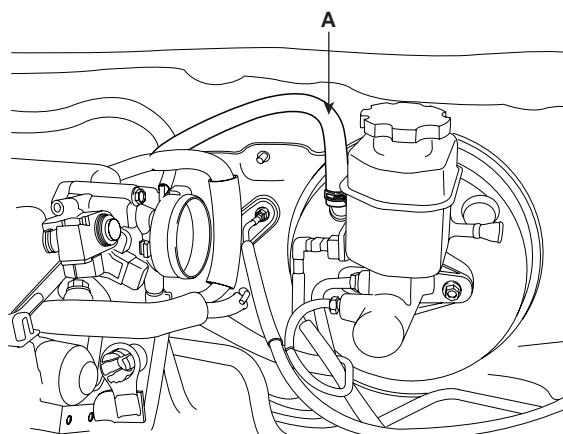

LUIF093A

19. Install the fuel inlet hose(A).

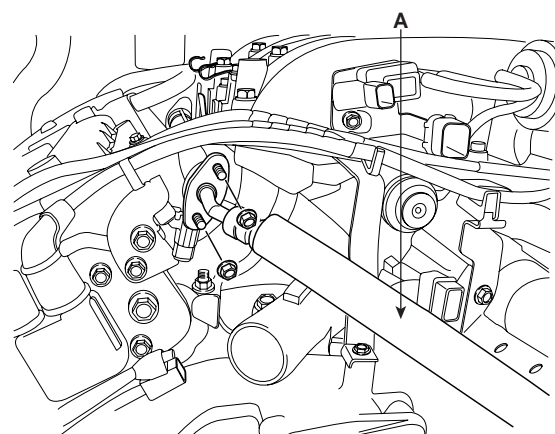

LUIF094A

20. Install the engine wire harness connectors and wire harness clamps to the cylinder head and the intake manifold.
 - 1) Oil pressure sensor connector(C).

CYLINDER HEAD ASSEMBLY

- 2) Air conditioner compressure switch connector(B).
- 3) Oxygen sensor (front 1st) connector(A).

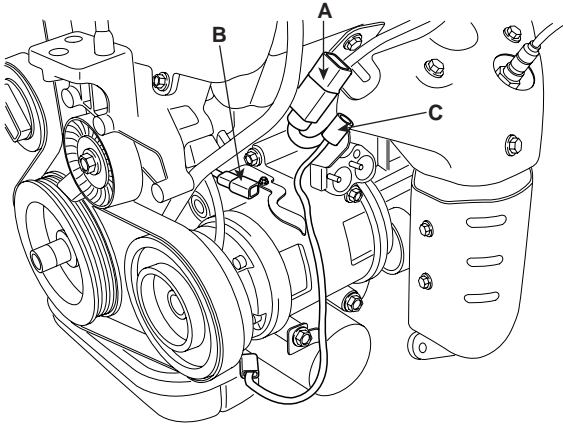

LUIF098A

- 4) Power steering pump switch(D).
- 5) Oxygen sensor (rear 2nd) connector(C).
- 6) VIS actuator connector(B).
- 7) IAT(Intake Air Temperature) sensor connector(A).

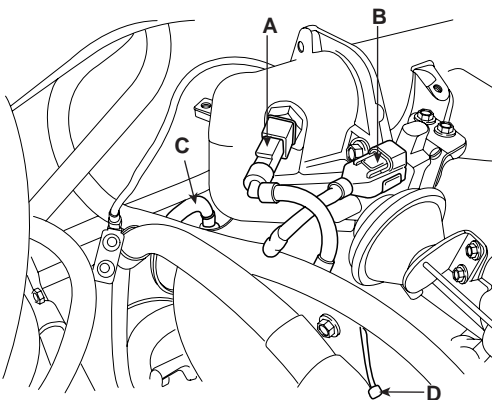

LUIF048A

- 8) Connect the ground cable(A) to the cowl panel.

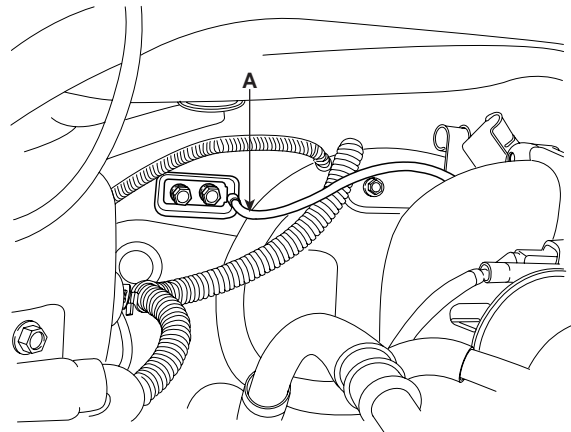

LUIF095A

- 9) Three fuel injector connectors(A).

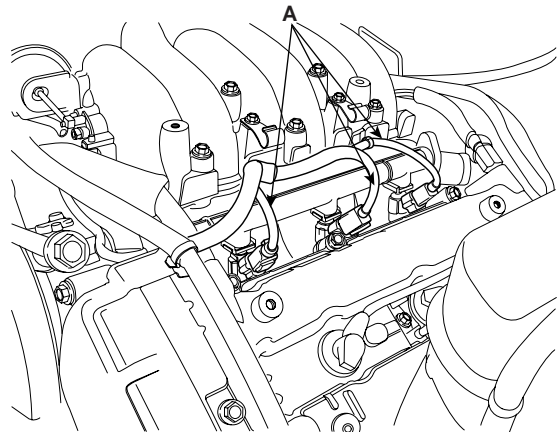

LUIF096A

- 10) Ground cable(E).
- 11) Oxygen sensor connector(D).
- 12) Crankshaft position sensor connector(C).
- 13) Ignition coil connector(B).
- 14) ECT sensor connector(A).

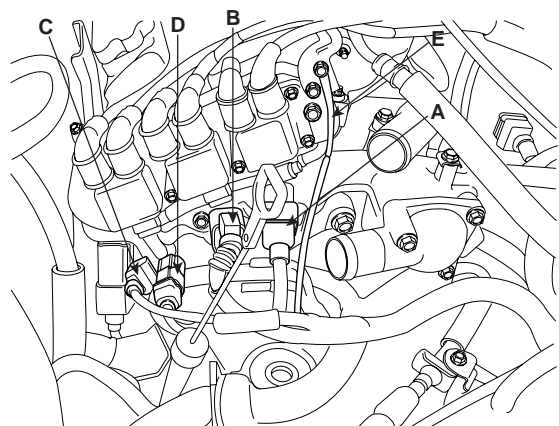

LUIF097A

EMB -40

ENGINE (G6BA - GASOLINE 2.7)

- 15) PCSV(Purge Control Solenoid Valve) hose(I).
- 16) Oxygen sensor (rear 1st) connector(H).
- 17) CMP(Camshaft position sensor) connector(G).
- 18) Knock sensor connector(F).
- 19) Injector connector(E).
- 20) VIS actuator connector(D).
- 21) PCSV(Purge Control Solenoid Valve) connector(C).
- 22) ISA connector(B).
- 23) TPS connector(A).

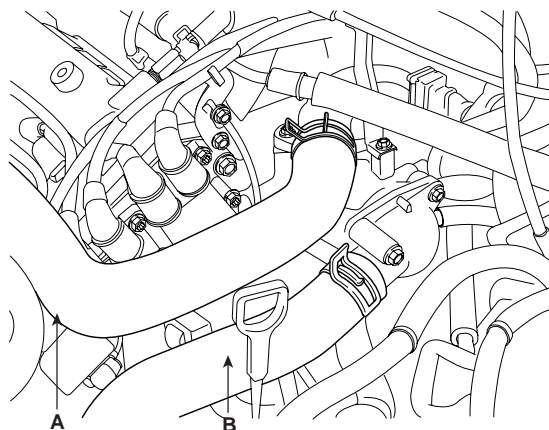

LUIF101A

- 23. Install the coolant reservoir tank(A).

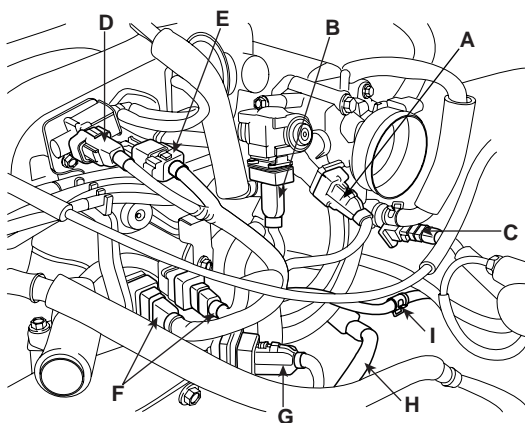

LUIF044A

- 21. Install the heater hoses(A) and throttle body heater hose(B).

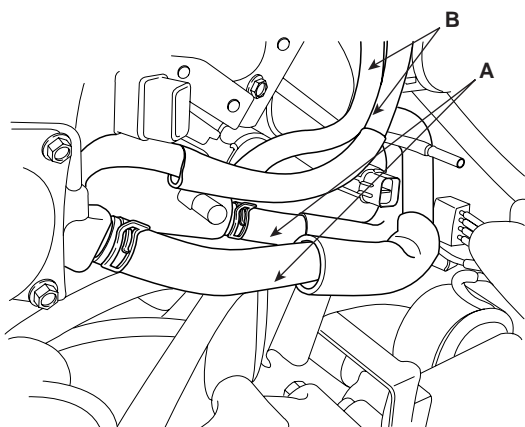

LUIF043A

- 22. Install the upper radiator hose(A) and lower radiator hose(B).

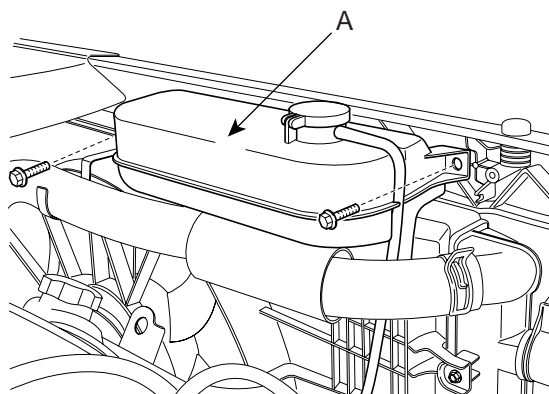

LUIF231A

- 24. Install the intake air hose and air cleaner assembly.

- 1) Install the intake air hose and air cleaner assembly(C).
- 2) Connect the breather hose(B) from air cleaner hose.
- 3) Connect the AFS connector(A).

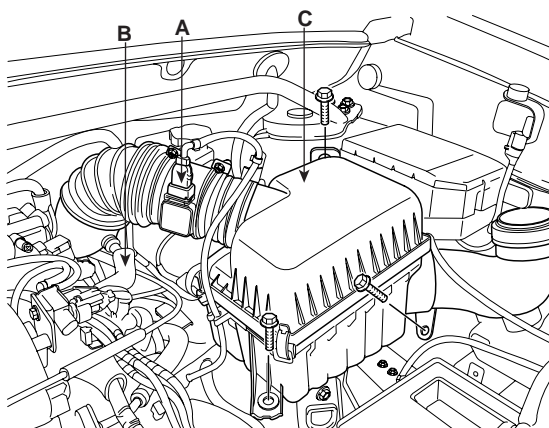

LUIF103A

CYLINDER HEAD ASSEMBLY

EMB -41

25. Install the engine cover.
26. Connect the negative terminal to the battery.

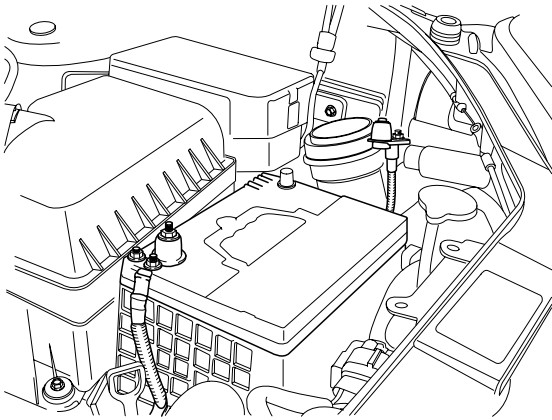

LUIF040A

27. Install the strut bar.
28. Install the cowl grill and wiper motor.(Refer to BE Gr.)
29. Install the air duct(A).

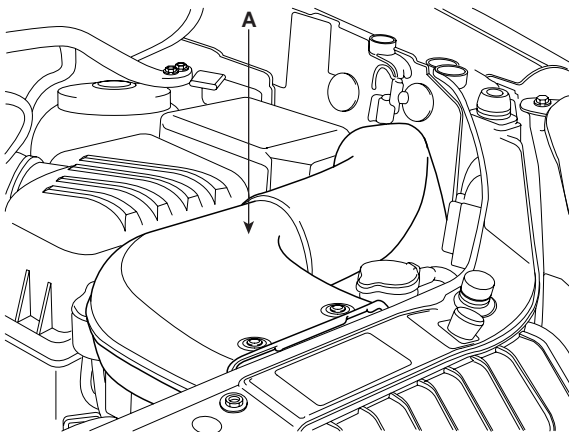

LUIF039A

30. Fill with engine coolant.
31. Start the engine and check for leaks.
32. Recheck engine coolant level and oil level.

ENGINE AND TRANSAXLE ASSEMBLY

REMOVAL ED82833F

CAUTION

- Use fender covers to avoid damaging painted surfaces.
- To avoid damage, unplug the wiring connectors carefully while holding the connector portion.

NOTE

- Mark all wiring and hoses to avoid misconnection.
- Inspect the timing belt before removing the cylinder head.
- Turn the crankshaft pulley so that the No. 1 piston is at top dead center. (See page EMB - 14)

1. Remove the air duct(A).

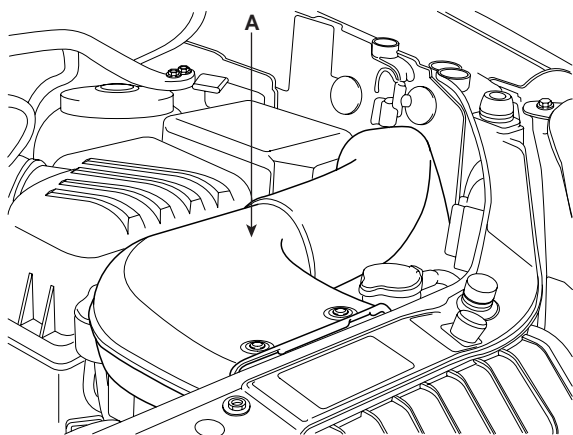

LUIF039A

2. Disconnect the negative terminal from the battery.

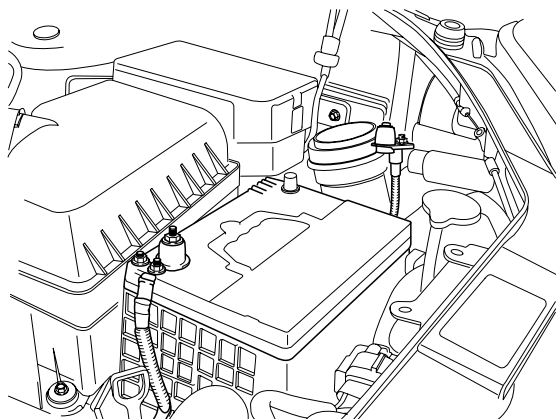

LUIF040A

3. Drain the engine coolant.
Remove the radiator cap to speed draining.

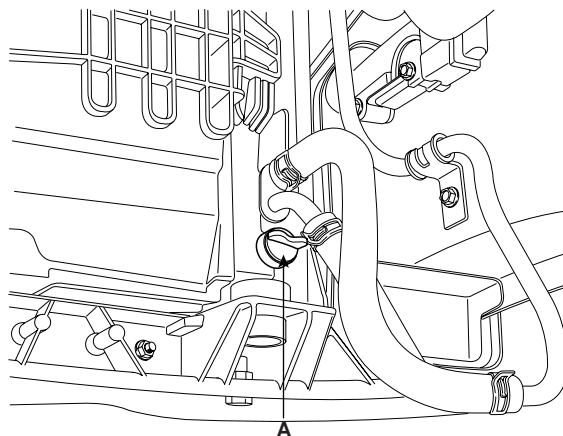

LUIF108A

4. Remove the engine cover.
5. Remove the intake air hose and air cleaner assembly.
 - 1) Disconnect the AFS connector(A).
 - 2) Disconnect the breather hose(B) from air cleaner hose.
 - 3) Remove the intake air hose and air cleaner assembly(C).

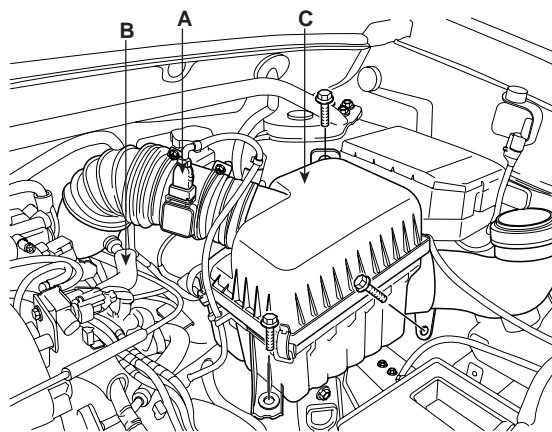

LUIF041A

6. Remove the upper radiator hose(A) and lower radiator hose(B).

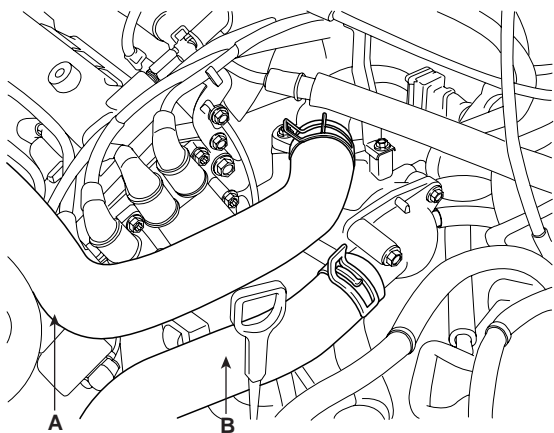

LUIF042A

- 8) Oxygen sensor (rear 1st) connector(H).
- 9) PCSV(Purge Control Solenoid Valve) hose(I).

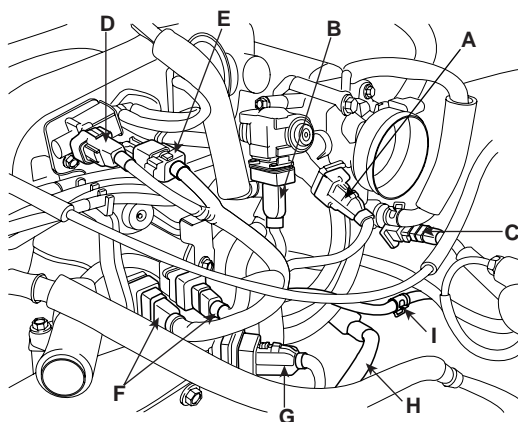

LUIF044A

7. Remove the heater hoses(A).

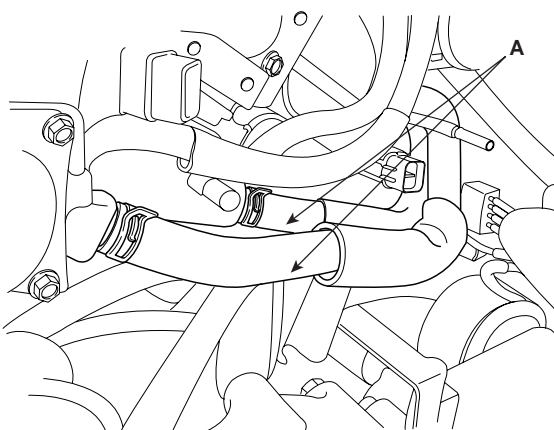

LUIF110A

- 10) ECT(Engine Coolant Temperature) sensor(A) connector.
- 11) Ignition coil connector(B).
- 12) Crankshaft position sensor connector(C).
- 13) Rear oxygen sensor(front 2nd) connector(D).
- 14) Ground cable(E).

8. Remove the engine wire harness connectors and wire harness clamps from the cylinder head and the intake manifold.

- 1) TPS(Throttle Position Sensor) connector(A).
- 2) ISA(Idle Speed Actuator) connector(B).
- 3) PCSV(Purge Control Solenoid Valve) connector(C).
- 4) VIS actuator connector(D).
- 5) Injector connector(E).
- 6) Knock sensor connector(F).
- 7) CMP(Camshaft Position Sensor) connector(G).

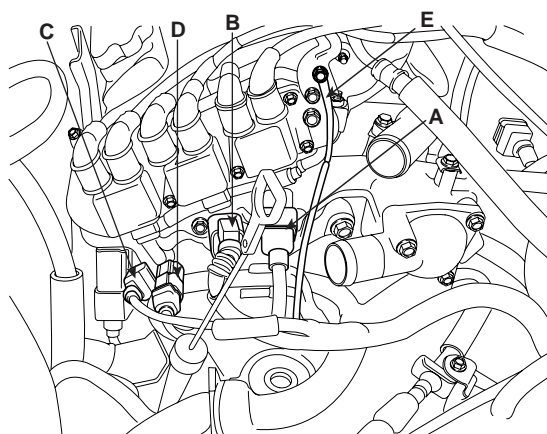

LUIF045A

- 15) Three fuel injector connectors(A).

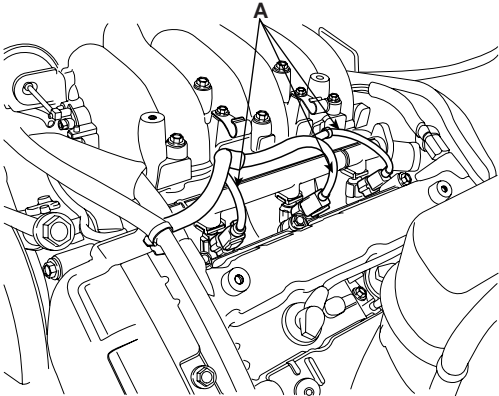

LUIF046A

- 16) Disconnect ground cable(A) from the cowl panel.

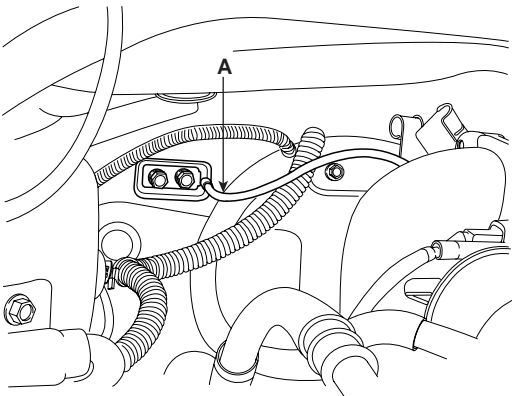

LUIF047A

- 17) Intake air temperature sensor connector(A).
18) VIS actuator connector(B).
19) Oxygen sensor(rear 2nd) connector(C).
20) Power steering pump switch(D).

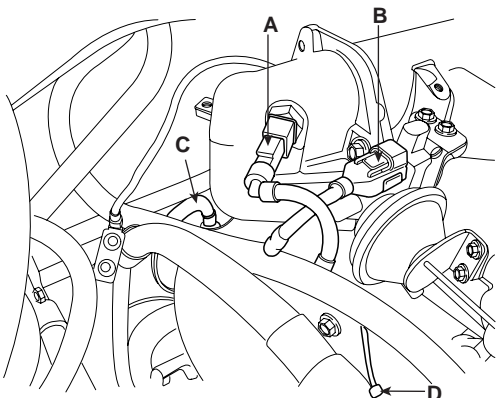

LUIF048A

9. Disconnect front heated oxygen sensor(LH) connector(A), air compressor switch connector(B) and oil pressure sensor connector(C).

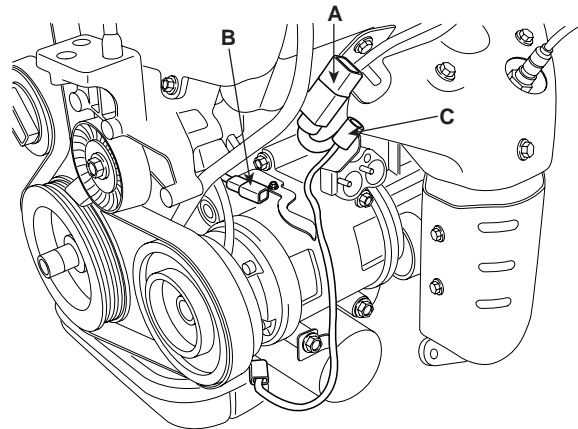

LUIF116A

10. Remove the fuel inlet from delivery pipe(A).

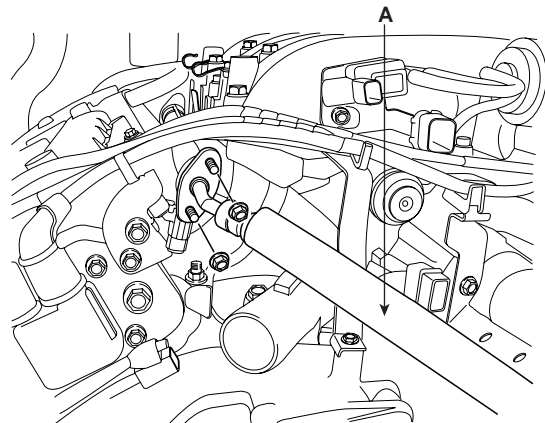

LUIF049A

11. Remove the brake booster vacuum hose(A).

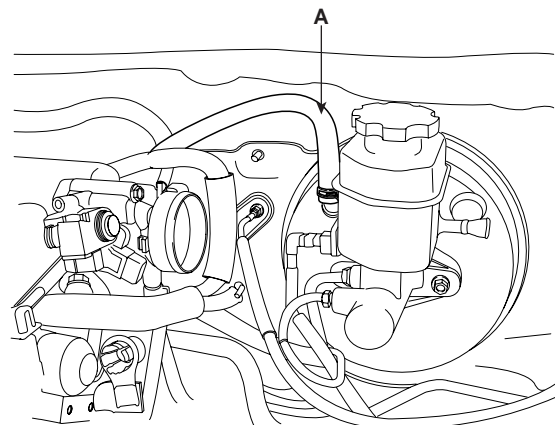

LUIF051A

12. Remove the accelerator cable by loosening the lock-nut, then slip the cable end out of the throttle linkage.

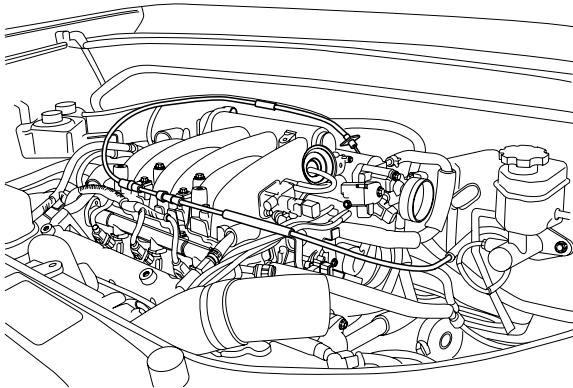

LUIF092A

13. Remove the power steering pump hose(A).

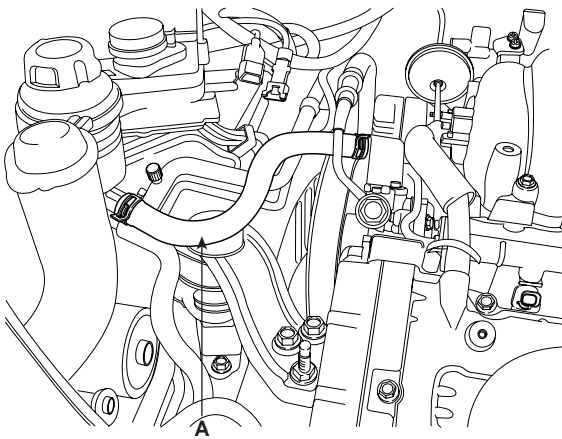

LUIF120A

14. Remove the battery body bracket.

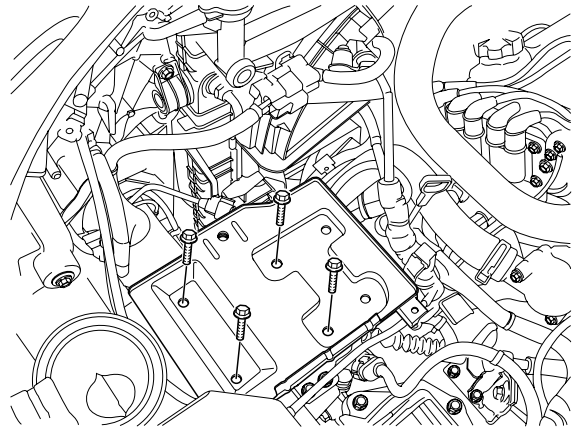

LUIF122A

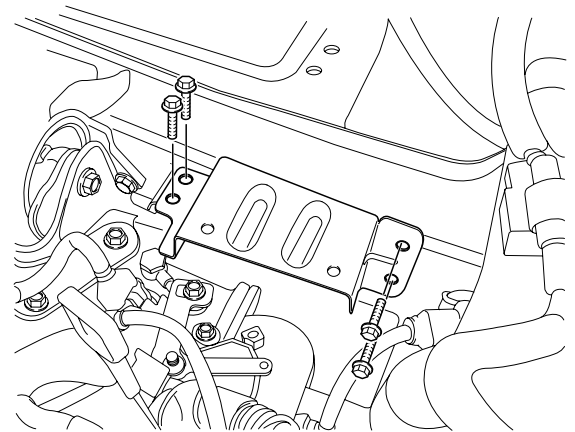

LUIF123A

15. Disconnect the transaxle wire harness connector.
a. Disconnect the inhibitor switch connector(A).
b. Disconnect the transaxle range connector(B).
c. Disconnect the input shaft speed connector(C).

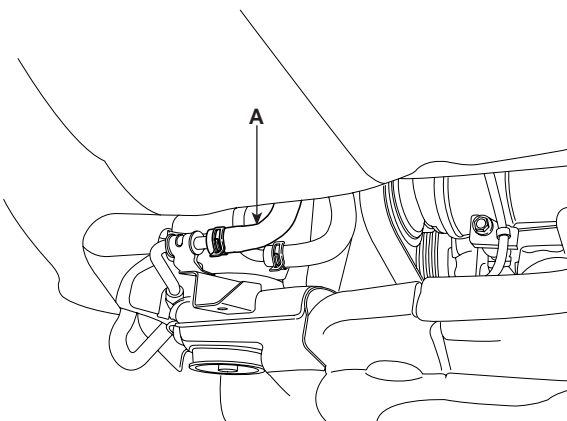

LUIF121A

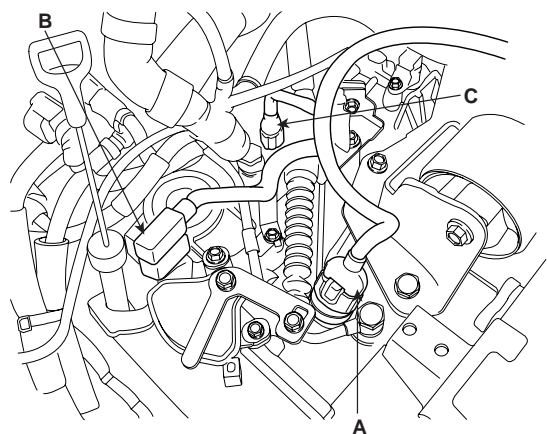

LUIF124A

EMB -46

ENGINE (G6BA - GASOLINE 2.7)

- d. Disconnect the output shaft speed connector(A).
- e. Disconnect the vehicle speed sensor connector(B).

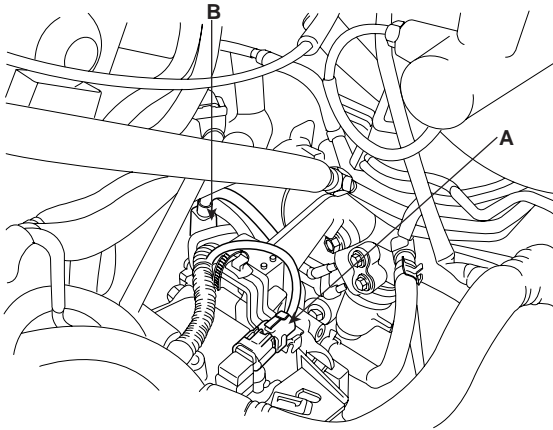

LUIF125A

- 18. Remove the under cover(A).

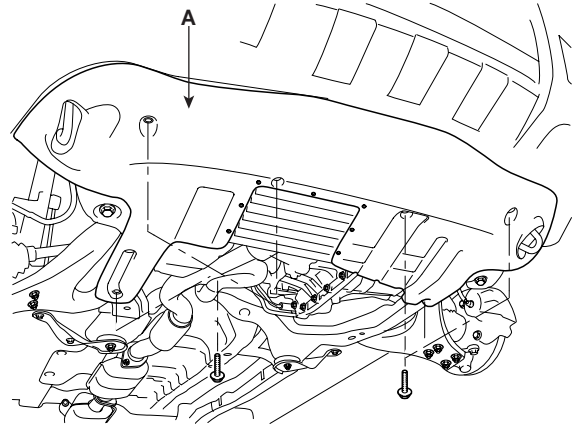

LUIF128A

- 16. Remove the control cable(A) transaxle range switch.

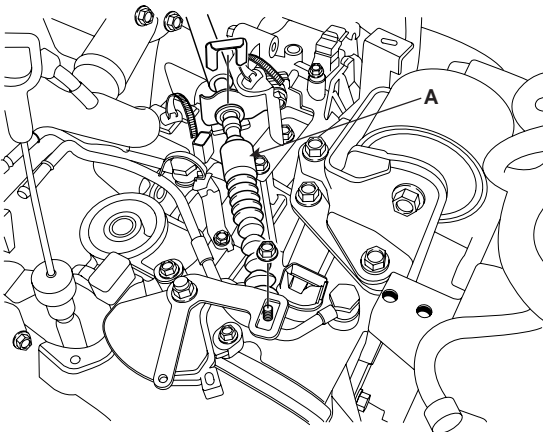

LUIF126A

- 19. Remove the front exhaust pipe(A).

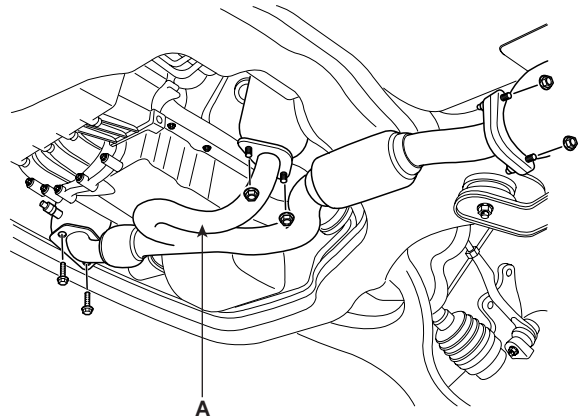

LUIF129A

- 17. Remove the transaxle oil cooler hoses(A/T)(A).

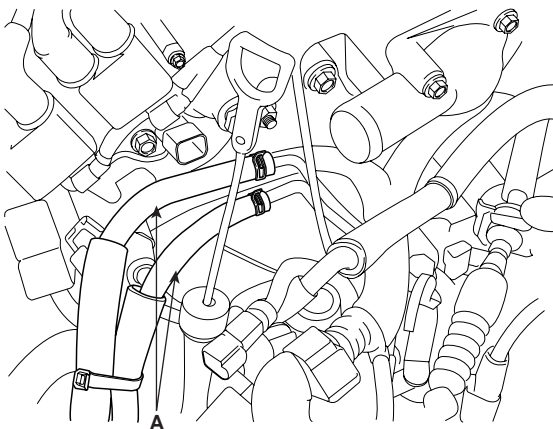

LUIF127A

- 20. Disconnect the ABS wheel speed sensor(A) from both front knuckles. (See DS group - front axle).

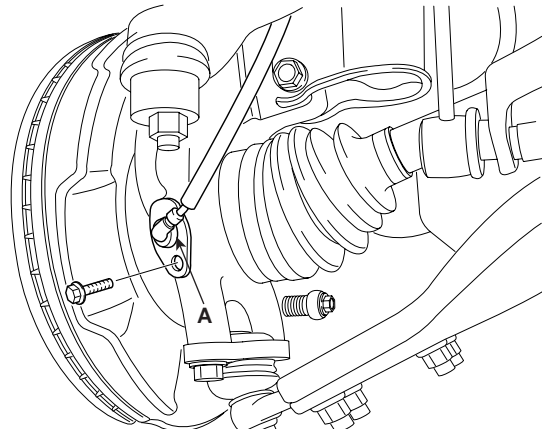

LUIF130A

21. Remove the front strut lower mounting bolts and nuts.
(See SS group - front strut).

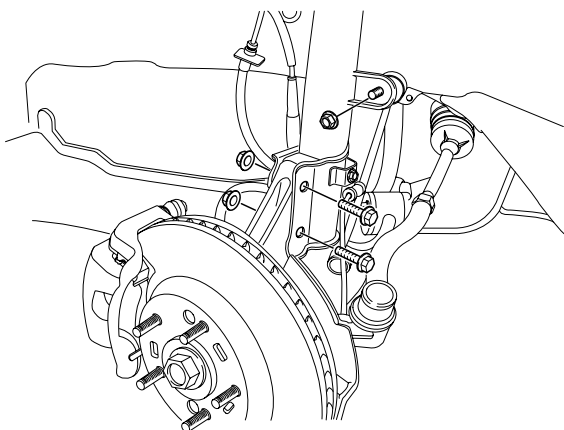

LUIF131A

22. Remove the caliper and hang the caliper assembly(A).

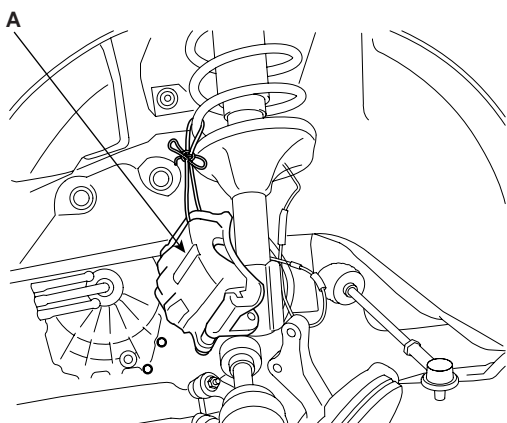

LUIF132A

23. Remove the steering u-joint mounting bolt(A). (See ST group - steering)

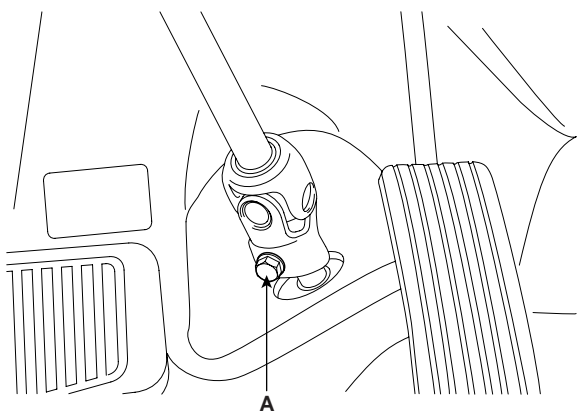

LUIF133A

24. Install the jack for supporting engine and transaxle assembly.

25. Remove the engine mounting bracket(A).

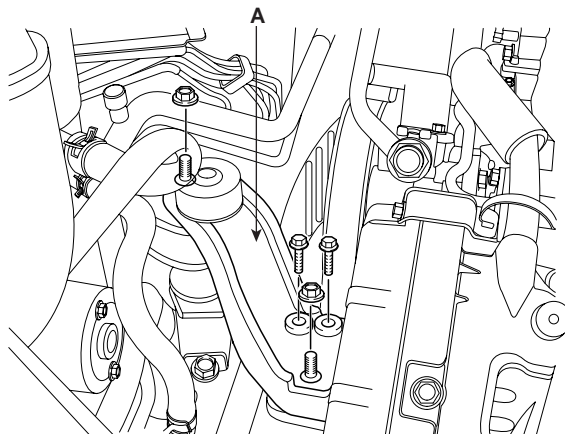

LUIF013A

26. Remove the transaxle mounting bracket(A).

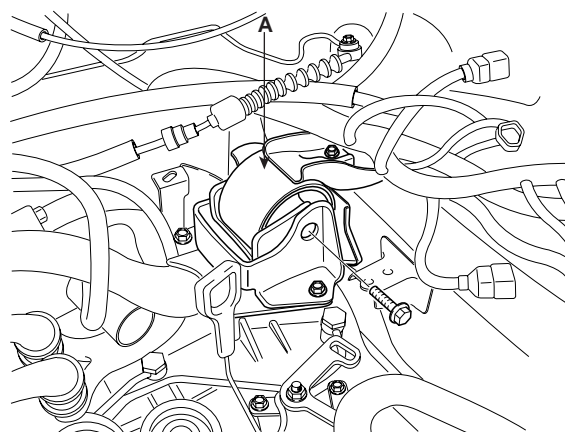

LUIF135A

27. Remove the sub frame mounting bolts and nuts.

Tightening torque

A : 160 ~ 180N.m (1600 ~ 1800kgf.cm, 118 ~ 133lbf.ft)

B : 70 ~ 90N.m (700 ~ 900kgf.cm, 52 ~ 66lbf.ft)

■ Rear

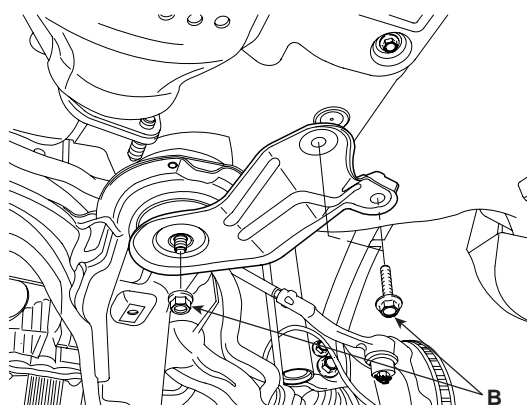

LUIF136A

■ Rear

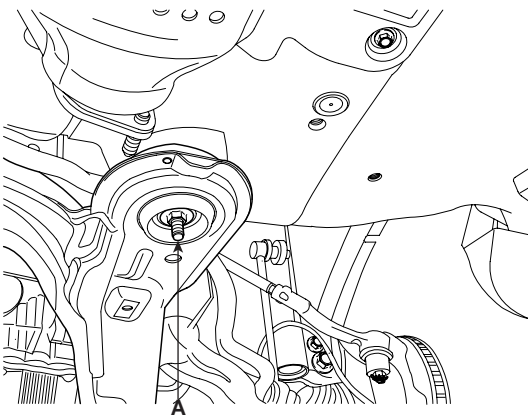

LUIF137A

■ Front

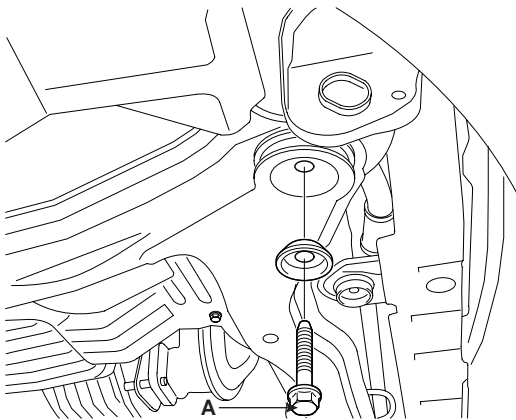

LUIF138A

INSTALLATION

E2EFEAAF

Installation is in the reverse order of removal.

Perform the following :

- Adjust the shift cable.
- Adjust the throttle cable.
- Refill the engine with engine oil.
- Refill the transaxle with fluid.
- Refill the radiator with engine coolant.
- Bleed air from the cooling system with the heater valve open.
- Clean the battery posts and cable terminals with sandpaper assemble them, then apply grease to prevent corrosion.
- Inspect for fuel leakage.

After assembling the fuel line, turn on the ignition switch (do not operate the starter) so that the fuel pump runs for approximately two seconds and fuel line pressureizes.

Repeat this operation two or three times, then check for fuel leakage at any point in the fuel line.

28. Jack up the vehicle.

ENGINE BLOCK

COMPONENT E2EF96B8

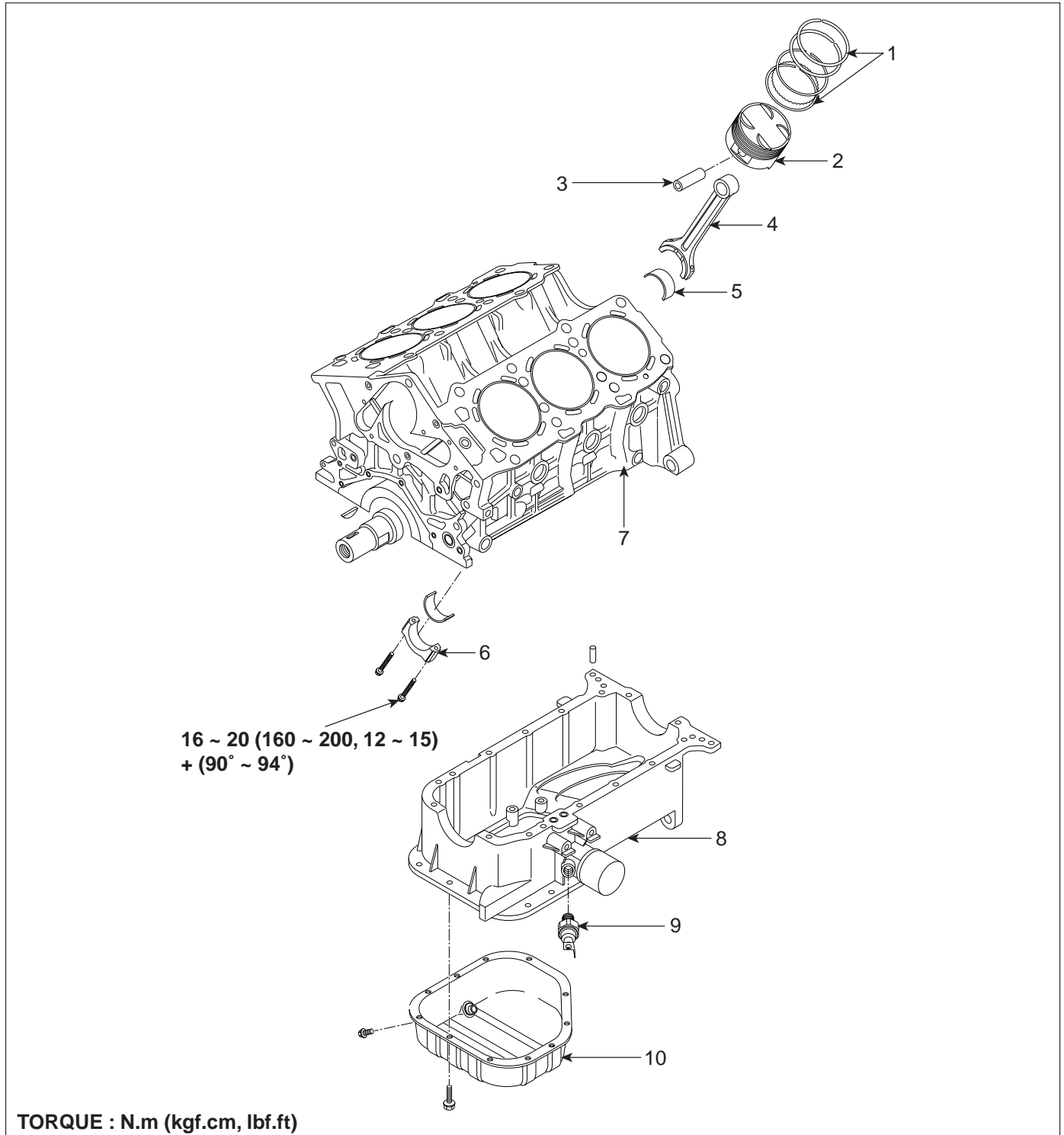

- | | |
|---------------------------|------------------------|
| 1. Piston ring | 6. Bearing cap |
| 2. Piston | 7. Cylinder block |
| 3. Piston pin | 8. Upper oil pan |
| 4. Connecting rod | 9. Oil pressure switch |
| 5. Connecting rod bearing | 10. Lower oil pan |

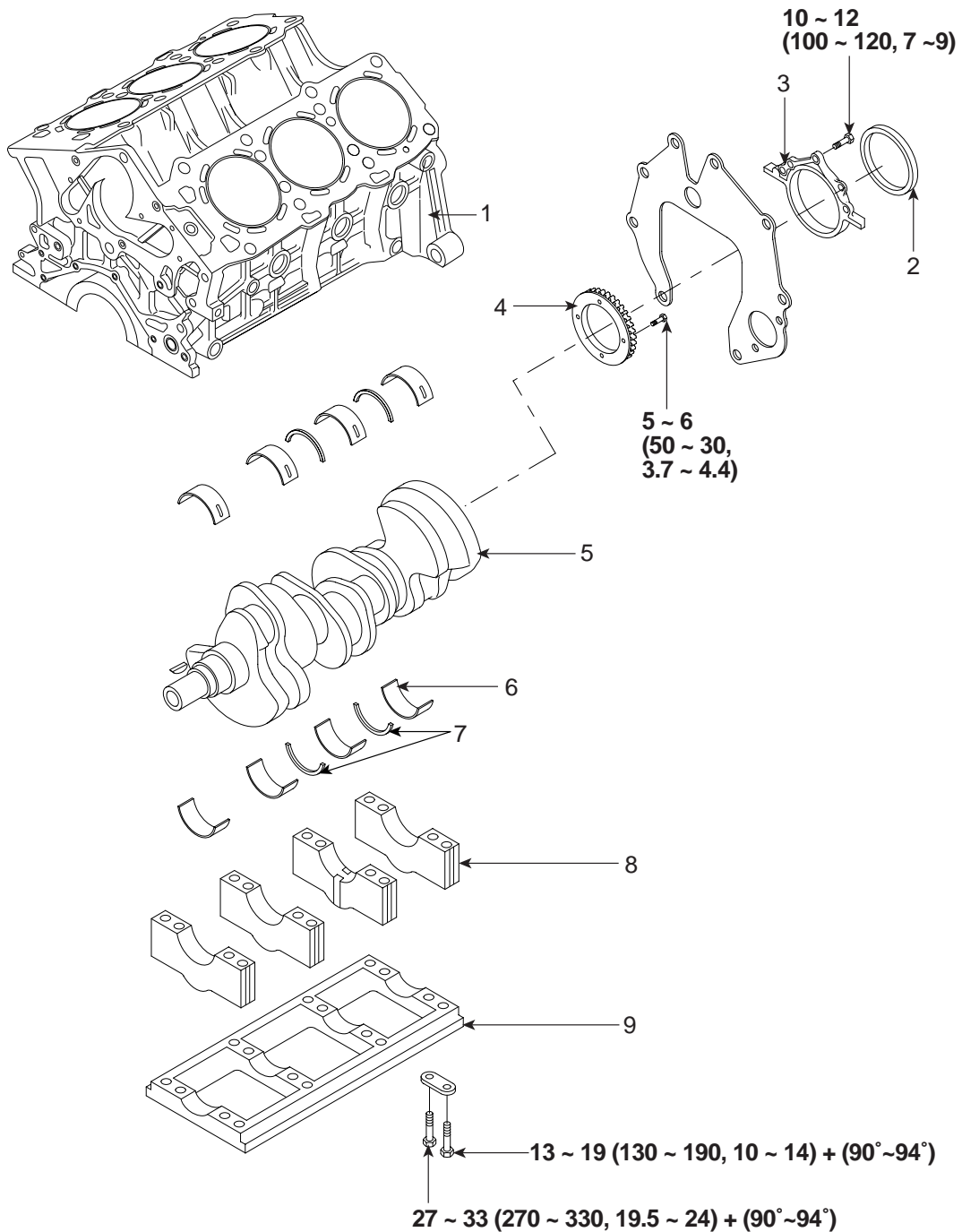

TORQUE : N.m (kgf.cm, lbf.ft)

- | | |
|-------------------------------------|-----------------------|
| 1. Cylinder block | 6. Main bearing |
| 2. Oil seal | 7. Thrust bearing |
| 3. Oil seal case | 8. Main bearing cap |
| 4. Crankshaft position sensor wheel | 9. Bearing cap bridge |
| 5. Crankshaft | |

DISASSEMBLY E34EFBEE

1. A/T : remove drive plate.
2. Install engine to engine stand for disassembly(A).
3. Remove timing belt. (See page EMB - 14).
4. Remove cylinder head. (See page EMB - 23)
5. Remove oil level gauge assembly.
6. Remove the alternator. (See EE group - alternator).
7. Remove the air compressor. (See HA group - air compressor)
8. Remove the power steering pump bracket(A).

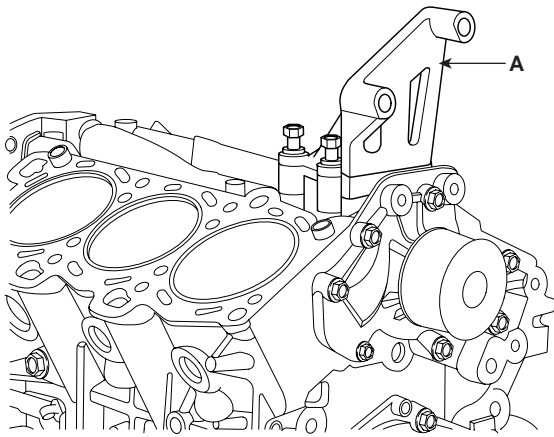

LUIF141A

9. Remove water pump. (See page EMB - 72)
10. Remove knock sensors(A).

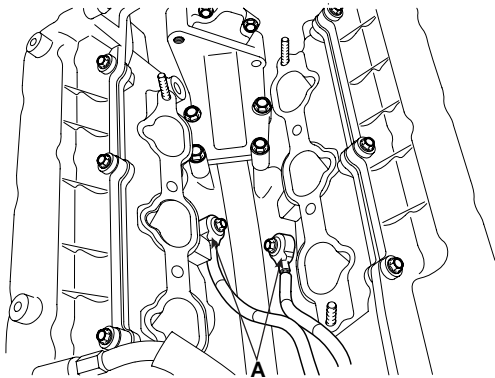

LUIF142A

11. Remove the lower oil pan(A).

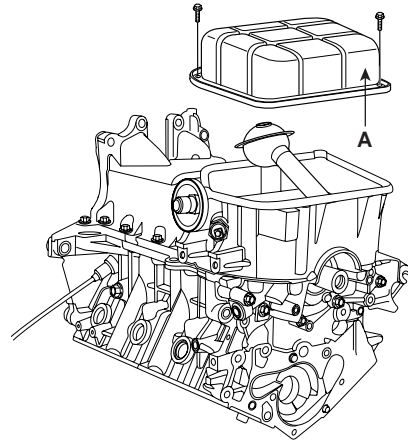

LUIF143A

12. Remove oil screen.
Remove the 2bolts(B), oil screen(A) and gasket.

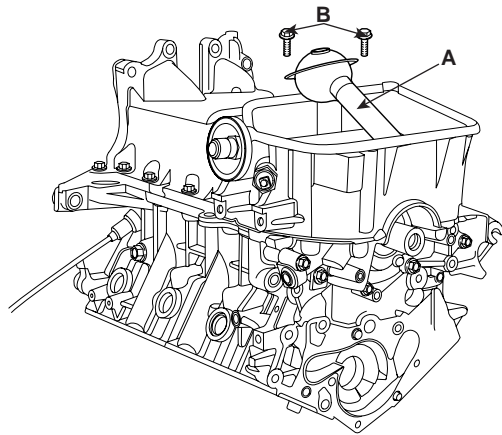

LUIF144A

13. Remove the upper oil pan(A).

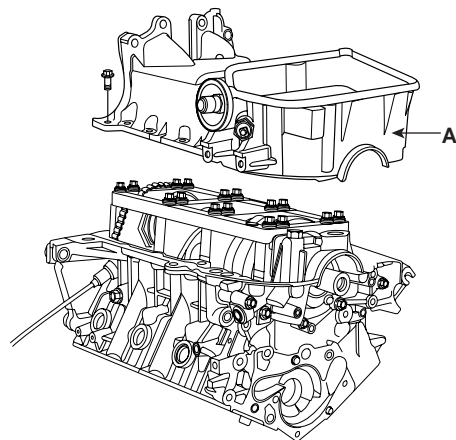

LUIF145A

14. Check the connecting rod end play. (See page EMB - 53)

EMB -52

ENGINE (G6BA - GASOLINE 2.7)

15. Remove the connecting rod caps and check oil clearance. (See page EMB - 53)
16. Remove piston and connecting rod assemblies.
 - 1) Using a ridge reamer, remove all the carbon from the top of the cylinder.
 - 2) Push the piston, connecting rod assembly and upper bearing through the top of the cylinder block.

NOTE

- Keep the bearings, connecting rod and cap together.
- Arrange the piston and connecting rod assemblies in the correct order.

17. Remove front case. (See page EMB - 80)
18. Remove oil seal case.
Remove the 3bolts(B) and oil seal case(A).

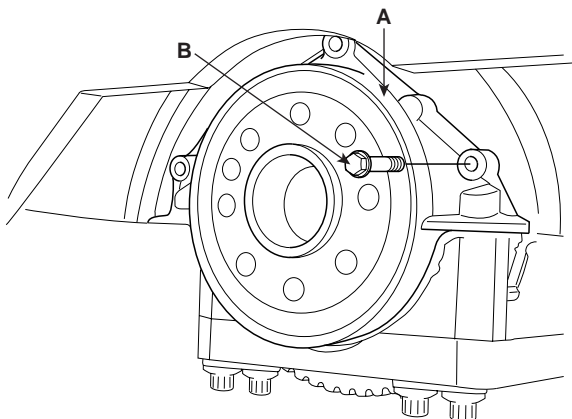

LUIF146A

19. Check the crankshaft end play. (See page EMB - 57)
20. Remove crankshaft bearing cap and check oil clearance. (See page EMB - 55)

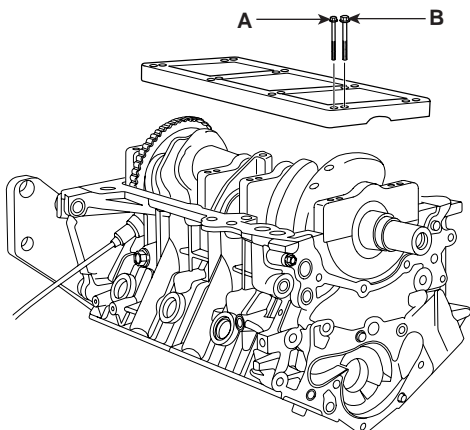

LUIF147A

21. Lift the crankshaft(A) out of the engine, being careful not to damage journals.

NOTE

Arrange the main bearings and trust washers in the correct order.

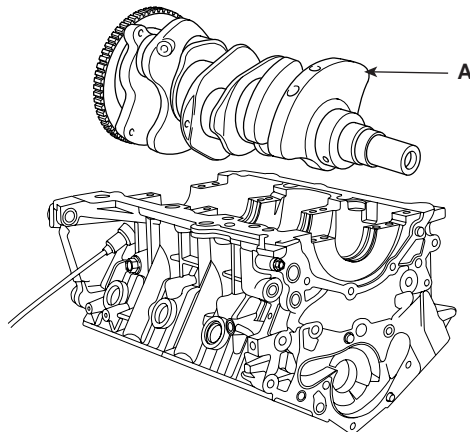

LUIF148A

22. Check fit between piston and piston pin.
Try to move the piston back and forth on the piston pin. If any movement is felt, replace the piston and pin as a set.
23. Remove piston rings.
 - 1) Using a piston ring expander, remove the 2 compression rings.
 - 2) Remove the 2side rails and oil ring by hand.

NOTE

Arrange the piston rings in the correct order only.

24. Disconnect connecting rod from piston.

INSPECTION ECCFB39

CONNECTING ROD AND CRANKSHAFT

1. Check the connecting rod end play.
Using a dial indicator, measure the end play while moving the connecting rod back and forth.

Standard end play : 0.1~ 0.25mm(0.004 ~ 0.010in.)
Maximum end play : 0.4mm(0.016in.)

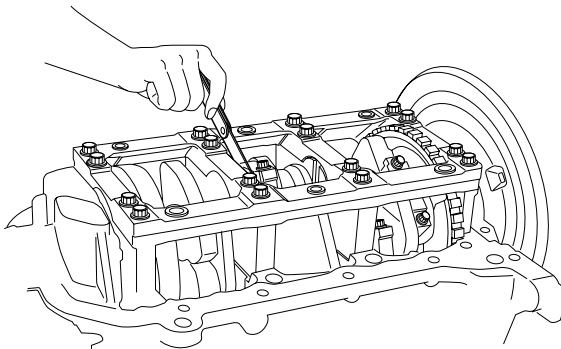

LUIF149A

- If out-of-tolerance, replace the connecting rod assembly.
- If still out-of-tolerance, replace the crankshaft.

2. Check the connecting rod bearing oil clearance.
 - 1) Check the matchmarks on the connecting rod and cap are aligned to ensure correct reassembly.
 - 2) Remove the 2 connecting rod cap bolts.
 - 3) Remove the connecting rod cap and bearing half.
 - 4) Clean the crank pin and bearing.
 - 5) Place plastigage across the crank pin.
 - 6) Reinstall the bearing half and cap, and torque the bolts.

Tightening torque

16 ~ 20N.m (160 ~ 200kgf.cm, 12 ~ 15lbf.ft) + 90°

 **NOTE**

Do not turn the crankshaft.

- 7) Remove the 2bolts, connecting rod cap and bearing half.

- 8) Measure the plastigage at its widest point.

Standard oil clearance

0.018 ~ 0.036mm(0.0007 ~ 0.0014in.)

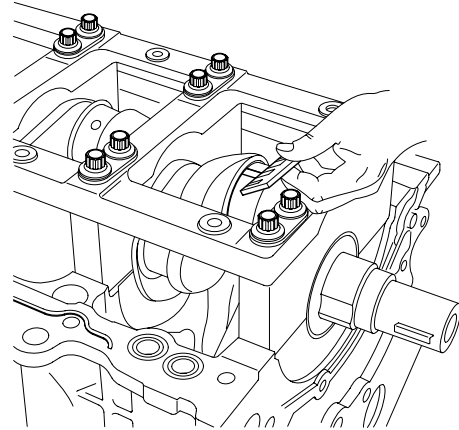

LUIF150A

- 9) If the plastigage measures too wide or too narrow, remove the upper half of the bearing, install a new, complete bearing with the same color mark (select the color as shown in the next column), and recheck the clearance.

 **CAUTION**

Do not file, shim, or scrape the bearings or the caps to adjust clearance.

- 10) If the plastigage shows the clearance is still incorrect, try the next larger or smaller bearing (the color listed above or below that one), and check clearance again.

 **NOTE**

If the proper clearance cannot be obtained by using the appropriate larger or smaller bearings, replace the crankshaft and start over.

 **CAUTION**

If the marks are indecipherable because of an accumulation of dirt and dust, do not scrub them with a wire brush or scraper. Clean them only with solvent or detergent.

Connecting rod mark location

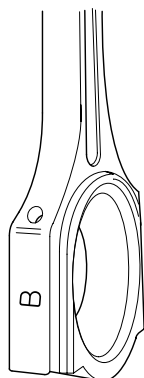

LUIF151A

Place of identification mark (Connecting rod bearing)

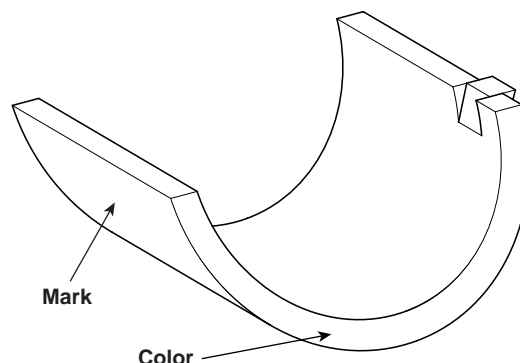

LUIF153A

Discrimination of connecting rod

CLASS	MARK	INSIDE DIAMETER
0	A	51.000 ~ 51.006mm (2.0079 ~ 2.0081in.)
1	B	51.006 ~ 51.012mm (2.0081 ~ 2.0083in.)
2	C	51.012 ~ 51.018mm (2.0083 ~ 2.0086in.)

Discrimination of connecting rod bearing

CLASS	MARK	THICKNESS OF BEARING
A	BLUE	1.500 ~ 1.503mm (0.0590 ~ 0.0591in.)
B	BLACK	1.497 ~ 1.500mm (0.0589 ~ 0.0590in.)
C	NONE	1.494 ~ 1.497mm (0.0588 ~ 0.0589in.)
D	GREEN	1.491 ~ 1.494mm (0.0587 ~ 0.0588in.)
E	YELLOW	1.488 ~ 1.491mm (0.0586 ~ 0.0587in.)

Crankshaft pin mark location

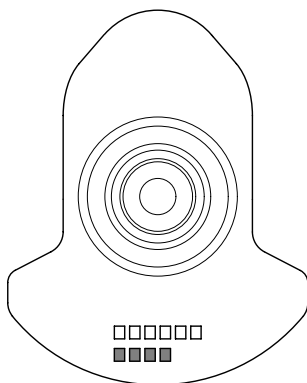

LUIF152A

Discrimination of crankshaft

CLSASS	MARK	OUTSIDE DIAMETER OF PIN
I	A	47.994 ~ 48.000mm (1.8895 ~ 1.8898in.)
II	B	47.988 ~ 47.994mm (1.8893 ~ 1.8895in.)
III	C	47.982 ~ 47.988mm (1.8890 ~ 1.8893in.)

11) Selection

CRANK-SHAFT IDENTIFICATION MARK	CONNECTING ROD IDENTIFICATION MARK	ASSEMBLING CLASSIFICATION OF BEARING
I (A)	0 (A)	E (YELLOW)
	1 (B)	D (GREEN)
	2 (C)	C (NONE)
II (B)	0 (A)	D (GREEN)
	1 (B)	C (NONE)
	2 (C)	B (BLACK)
III (C)	0 (A)	C (NONE)
	1 (B)	B (BLACK)
	2 (C)	A (BLUE)

3. Check the crankshaft bearing oil clearance.
 - 1) To check main bearing-to-journal oil clearance, remove the main caps and bearing halves.
 - 2) Clean each main journal and bearing half with a clean shop towel.
 - 3) Place one strip of plastigage across each main journal.
 - 4) Reinstall the bearings and caps, then torque the bolts.

- 7) If the plastigage shows the clearance is still incorrect, try the next larger or smaller bearing (the color listed above or below that one), and check clearance again.

 **NOTE**

If the proper clearance cannot be obtained by using the appropriate larger or smaller bearings, replace the crankshaft and start over.

 **CAUTION**

If the marks are indecipherable because of an accumulation of dirt and dust, do not scrub them with a wire brush or scraper. Clean them only with solvent or detergent.

Tightening torque

M8

13 ~ 19N.m (130 ~ 190kgf.cm, 10 ~ 14lbf.ft) + 90°

M10

27 ~ 33N.m (270 ~ 330kgf.cm, 19.5 ~ 24lbf.ft) + 90°

 **NOTE**

Do not turn the crankshaft.

- 5) Remove the cap and bearing again, and measure the widest part of the plastigage.

Standard oil clearance

0.004 ~ 0.022mm (0.00016 ~ 0.00087in.)

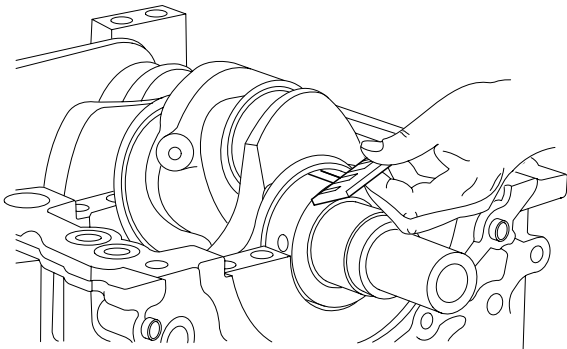

LUIF154A

- 6) If the plastigage measures too wide or too narrow, remove the upper half of the bearing, install a new, complete bearing with the same color mark (select the color as shown in the next column), and recheck the clearance.

 **CAUTION**

Do not file, shim, or scrape the bearings or the caps to adjust clearance.

CONNECTING RODS

1. When reinstalling, make sure that cylinder numbers put on the connecting rod and cap at disassembly match. When a new connecting rod is installed, make sure that the notches for holding the bearing in place are on the same side.
2. Replace the connecting rod if it is damaged on the thrust faces at either end. Also if step wear or a severely rough surface of the inside diameter of the small end is apparent, the rod must be replaced as well.
3. Using a connecting rod aligning tool, check the rod for bend and twist. If the measured value is close to the repair limit, correct the rod by a press. Any connecting rod that has been severely bent or distorted should be replaced.

Allowable bend of connecting rod
0.05mm / 100mm (0.0020 in./3.94 in.) or less
Allowable twist of connecting rod
0.1mm / 100mm (0.0039 in./3.94 in.) or less

Crankshaft bore mark location

Letters have been stamped on the end of the block as a mark for the size of each of the 4 main journal bores.

Use them, and the numbers or bar stamped on the crank (marks for main journal size), to choose the correct bearings.

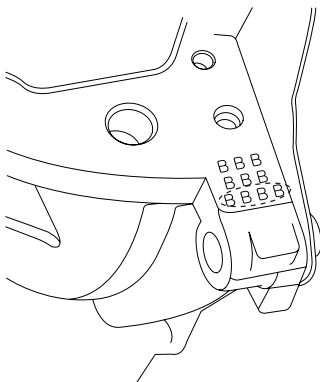

LUIF155A

Discrimination of cylinder block

CALSS	MARK	INSIDE DIAMETER
a	A	66.000 ~ 66.006mm (2.5984 ~ 2.5986in.)
b	B	66.006 ~ 66.012mm (2.5986 ~ 2.5989in.)
c	C	66.012 ~ 66.018mm (2.5989 ~ 2.5991in.)

Crankshaft journal mark location

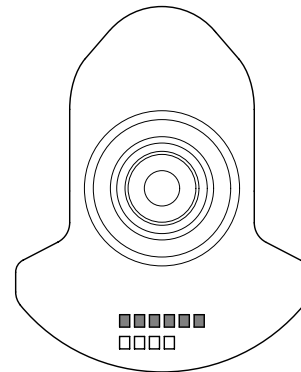

LUIF156A

Discrimination of crankshaft

CLASS	MARK	OUTSIDE DIAMETER OF JOURNAL
I	A	61.994 ~ 62.000mm (2.4407 ~ 2.4409in.)
II	B	61.988 ~ 61.994mm (2.4405 ~ 2.4407in.)
III	C	61.982 ~ 61.988mm (2.4402 ~ 2.4405in.)

Place of identification mark (Crankshaft bearing)

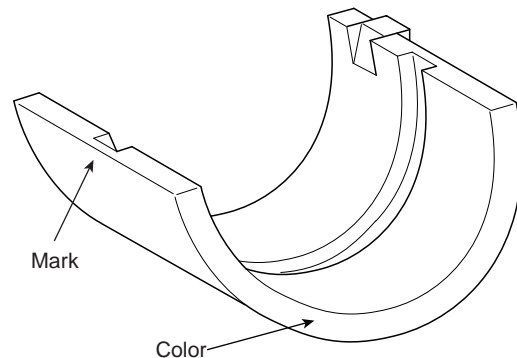

LUIF157A

Discrimination of crankshaft bearing

CLASS	MARK	THICKNESS OF BEARING
A	BLUE	2.007 ~ 2.010mm (0.0790 ~ 0.0791in.)
B	BLACK	2.004 ~ 2.007mm (0.0789 ~ 0.0790in.)
C	NONE	2.001 ~ 2.004mm (0.0788 ~ 0.0789in.)
D	GREEN	1.998 ~ 2.001mm (0.0787 ~ 0.788in.)
E	YELLOW	1.995 ~ 1.998mm (0.0785 ~ 0.0787in.)

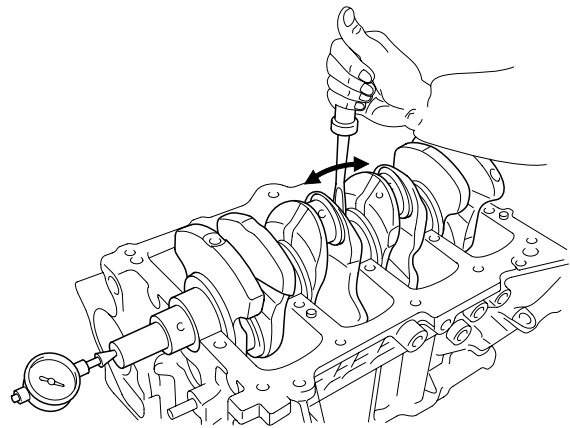

LUIF158A

If the end play is greater than maximum, replace the thrust bearings as a set.

Selection

CRANK-SHAFT IDENTIFICATION MARK	CRANKSHAFT BORE IDENTIFICATION MARK	ASSEMBLING CLASSIFICATION OF BEARING
I (A)	a (A)	E (YELLOW)
	b (B)	D (GREEN)
	c (C)	C (NONE)
II (B)	a (A)	D (GREEN)
	b (B)	C (NONE)
	c (C)	B (BLACK)
III (C)	a (A)	C (NONE)
	b (B)	B (BLACK)
	c (C)	A (BLUE)

Thrust bearing thickness
2.05 ~ 2.09mm (0.081 ~ 0.082in.)

- Inspect main journals and crank pins
Using a micrometer, measure the diameter of each main journal and crank pin.

Main journal diameter
61.982 ~ 62.000mm (2.4402 ~ 2.4409in.)
Crank pin diameter
47.982 ~ 48.000mm (1.8890 ~ 1.8898in.)

- Check crankshaft end play.
Using a dial indicator, measure the thrust clearance while prying the crankshaft back and forth with a screwdriver.

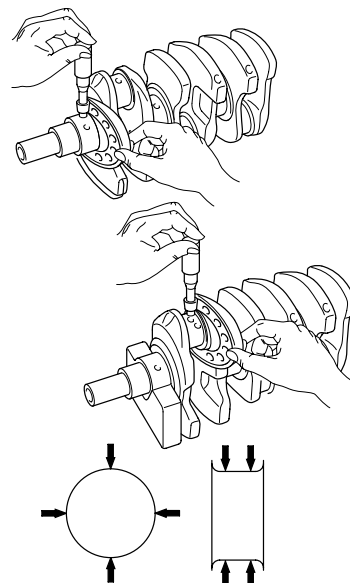

Standard end play
0.07 ~ 0.25mm (0.0027 ~ 0.0098in.)
Limit : 0.30mm (0.0118in.)

LUIF159A

CYLINDER BLOCK

1. Remove gasket material.
Using a gasket scraper, remove all the gasket material from the top surface of the cylinder block.
2. Clean cylinder block
Using a soft brush and solvent, thoroughly clean the cylinder block.
3. Inspect top surface of cylinder block for flatness.
Using a precision straight edge and feeler gauge, measure the surface contacting the cylinder head gasket for warpage.

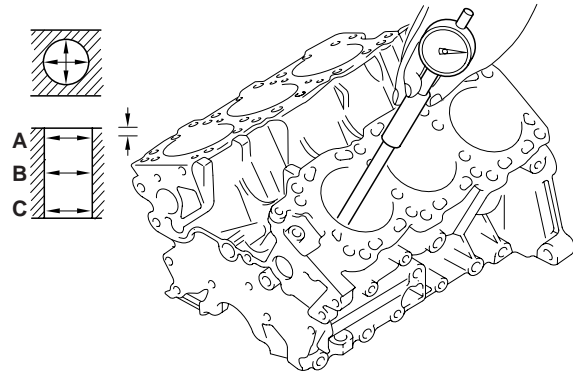

Flatness of cylinder block gasket surface

Standard : Less than 0.03mm(0.0012 in.)
Limit : 0.05 mm (0.0020 in.)

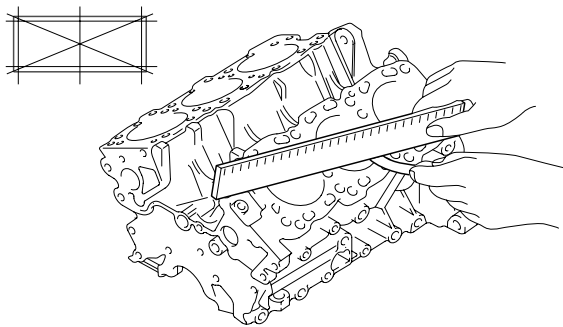

LUIF160A

4. Inspect cylinder bore diameter
Visually check the cylinder for vertical scratches.
If deep scratches are present, replace the cylinder liner.
5. Inspect cylinder bore diameter
Using a cylinder bore gauge, measure the cylinder bore diameter at position A, B and C in the thrust and axial directions.

Standard diameter

86.70 ~ 86.73mm (3.4134 ~ 3.4145in.)

6. Check the cylinder bore size code(A) on the cylinder block bottom face.

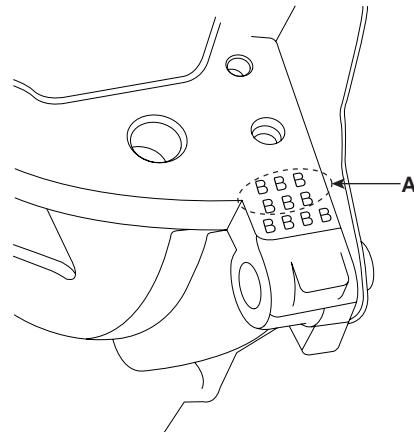

LUIF161A

LUIF162A

Class	Cylinder bore inner diameter	Size code
A	86.70 ~ 86.71mm (3.4133 ~ 3.4137in.)	A
B	86.71 ~ 86.72mm (3.4137 ~ 3.4141in.)	B
C	86.72 ~ 86.73mm (3.4141 ~ 3.4145in.)	C

7. Check the piston size code(A) on the piston top face.

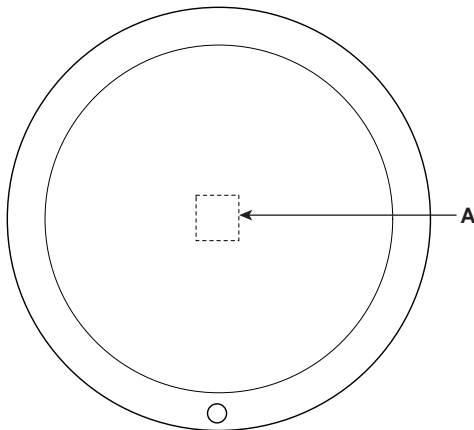

LUIF163A

NOTE

Stamp the grade mark of basic diameter with rubber stamp.

Class	Piston diameter	Size code
A	86.68 ~ 86.69mm (3.4126 ~ 3.4130in.)	A
B	86.69 ~ 86.70mm (3.4130 ~ 3.4133in.)	None
C	86.70 ~ 86.71mm (3.4133 ~ 3.4137in.)	C

8. Select the piston related to cylinder bore class.

Clearance : 0.01 ~ 0.03mm (0.0004 ~ 0.0012in.)

BORING CYLINDER

1. Oversize pistons should be selected according to the largest bore cylinder.

Identification Mark	Size
0.25	0.25mm (0.010in.)
0.50	0.50mm (0.0250in.)

NOTE

The size of piston is stamped on top of the piston.

2. Measure the outside diameter of the piston to be used.
3. According to the measured O.D., calculate the new bore size.

New bore size = Piston O.D + 0.01 to 0.03mm (0.0004 to 0.0012 in.) (clearance between piston and cylinder) - 0.01 mm (0.0004 in.) (honing margin.)

4. Bore each of the cylinders to the calculated size.

CAUTION

To prevent distortion that may result from temperature rise during honing, bore the cylinder holes in the firing order.

- 5.hone the cylinders, finishing them to the proper dimension (piston outside diameter + gap with cylinder).
6. Check the clearance between the piston and cylinder.

Standard : 0.01 ~ 0.03mm (0.0004 ~ 0.0012 in.)

NOTE

When boring the cylinders, finish all of the cylinders to the same oversize. Do not bore only one cylinder to the oversize.

PISTON AND RINGS

1. Clean piston

- 1) Using a gasket scraper, remove the carbon from the piston top.
- 2) Using a groove cleaning tool or broken ring, clean the piston ring grooves.
- 3) Using solvent and a brush, thoroughly clean the piston.

NOTE

Do not use a wire brush.

2. The standard measurement of the piston outside diameter is taken 38.5mm (1.516in.) from the top land of the piston.

Standard diameter

86.68 ~ 86.71mm (3.4126 ~ 3.4138in.)

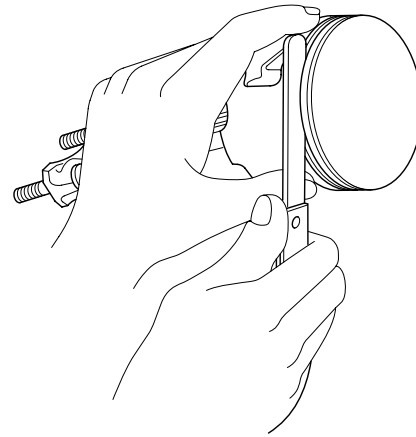

LUIF165A

If the clearance is greater than maximum, replace the piston.

5. Inspect piston ring end gap.

To measure the piston ring end gap, insert a piston ring into the cylinder bore. Position the ring at right angles to the cylinder wall by gently pressing it down with a piston. Measure the gap with a feeler gauge. If the gap exceeds the service limit, replace the piston ring. If the gap is too large, recheck the cylinder bore diameter against the wear limits on page EMB - 58, If the bore is over the service limit, the cylinder block must be rebored. (See page EMB - 58).

Piston ring end gap

Standard

No.1 : 0.20 ~ 0.35mm (0.0079 ~ 0.0138in.)

No.2 : 0.37 ~ 0.52mm (0.0146 ~ 0.0205in.)

Limit

Oil ring : 0.2 ~ 0.7mm (0.0079 ~ 0.0276in.)

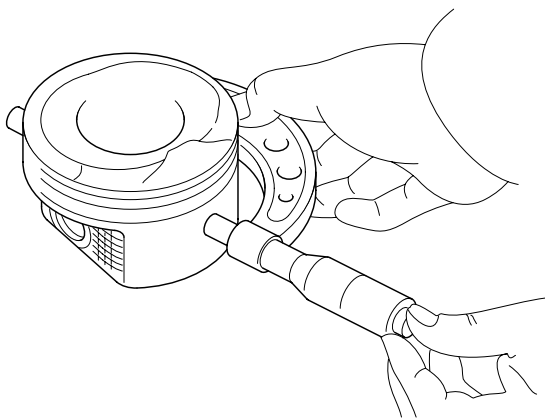

LUIF164A

3. Calculate the difference between the cylinder bore diameter and the piston diameter.

Piston-to-cylinder clearance

0.01 ~ 0.03mm(0.0004 ~ 0.0012in.)

4. Inspect the piston ring side clearance.

Using a feeler gauge, measure the clearance between new piston ring and the wall of the ring groove.

Piston ring side clearance

No. 1 : 0.04 ~ 0.08 mm (0.0016 ~ 0.0031 in.)

No. 2 : 0.03 ~ 0.07 mm (0.0012 ~ 0.0028 in.)

Limit

No. 1 : 0.1mm (0.004in.)

No. 2 : 0.1mm (0.004in.)

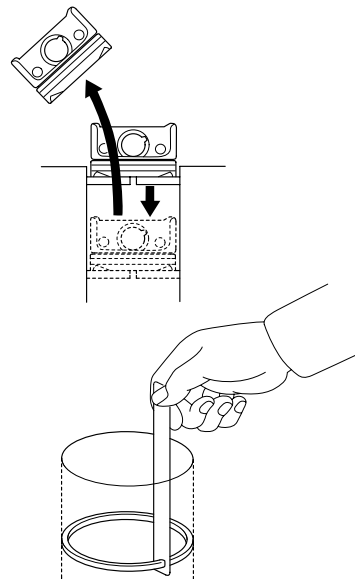

LUIF166A

PISTON PINS

1. Measure the diameter of the piston pin.

Piston pin diameter

21.001 ~ 21.007mm (0.8268 ~ 0.8270in.)

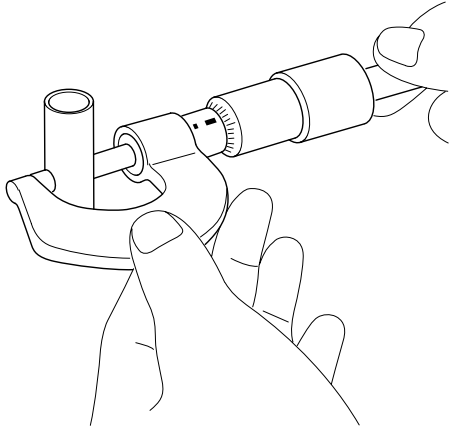

LUIF167A

2. Measure the piston pin-to-piston clearance.

Piston pin-to-piston clearance

0.007 ~ 0.022mm (0.00027 ~ 0.00086in.)

3. Check the difference between the piston pin diameter and the connecting rod small end diameter.

Piston pin-to-connecting rod interference

0.016 ~ 0.033mm (0.00063 ~ 0.00130in.)

OIL PRESSURE SWITCH

1. Check the continuity between the terminal and the body with an ohmmeter. If there is no continuity, replace the oil pressure switch.

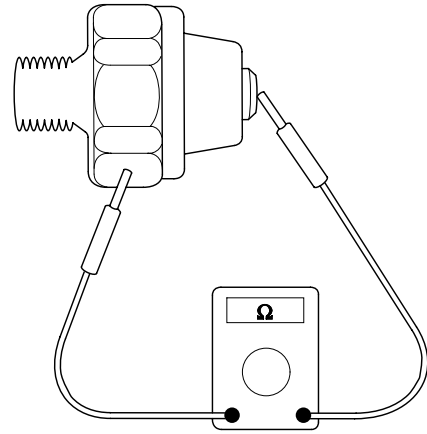

LUIF168A

2. Check the continuity between the terminal and the body when the fine wire is pushed. If there is continuity even when the fine wire is pushed, replace the switch.
3. If there is no continuity when a 50kpa (7psi) vacuum is applied through the oil hole, the switch is operating properly. Check for air leakage. If air leaks, the diaphragm is broken. Replace it.

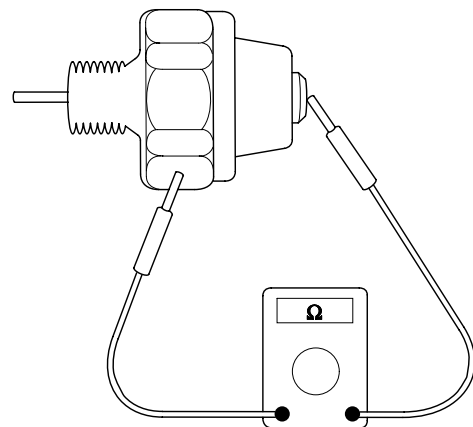

LUIF169A

REASSEMBLY

E944E4E7

 **NOTE**

- Thoroughly clean all parts to assembled.
- Before installing the parts, apply fresh engine oil to all sliding and rotating surfaces.
- Replace all gaskets, O-rings and oil seals with new parts.

1. Assemble piston and connecting rod.

- 1) Use a hydraulic press for installation.
- 2) The piston front mark(A) and the connecting rod front mark(B) must face the timing belt side of the engine.

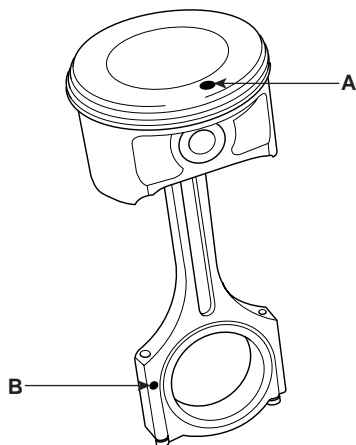

LUIF170A

2. Install piston rings.

- 1) Install the oil ring expander and 2 side rails by hand.
- 2) Using a piston ring expander, install the 2 compression rings with the code mark facing upward.
- 3) Position the piston rings so that the ring ends are as shown.

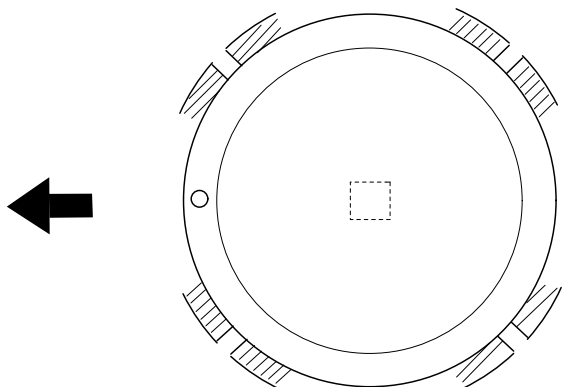

LUIF171A

3. Install connecting rod bearings.

- 1) Align the bearing claw with the groove of the connecting rod or connecting rod cap.
- 2) Install the bearings in the connecting rod and connecting rod cap.

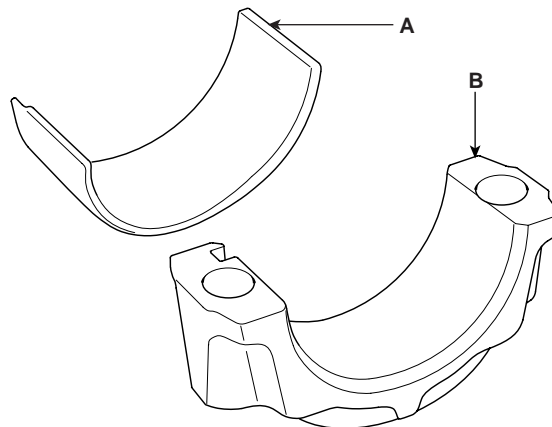

LUIF172A

4. Install main bearings.

 **NOTE**

Upper 1, 2, 3, 4 bearings have an oil groove of oil holes; Lower bearings do not.

- 1) Align the bearing claw with the claw groove of the cylinder block, push in the 4 upper bearings(A).

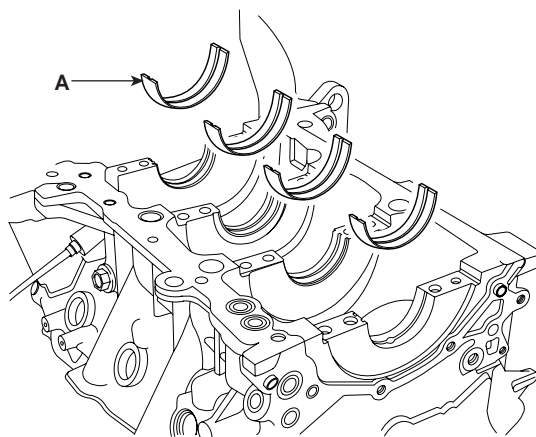

LUIF173A

- 2) Align the bearing claw with the claw groove of the main bearing cap(A), and push in the 4 lower bearings(B).

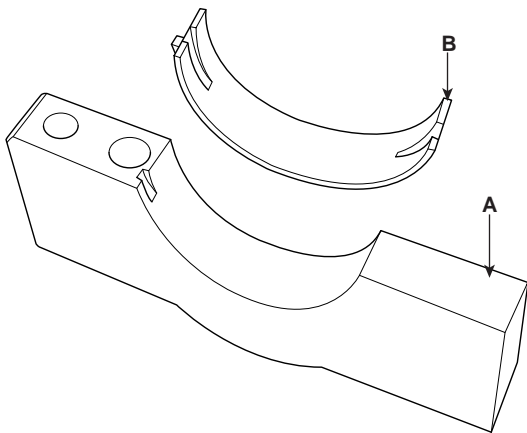

LUIF174A

7. Place main bearing caps on cylinder block.
8. Install main bearing cap bolts.

NOTE

- The main bearing cap bolts are tightened in 2 progressive steps.
- If any of the bearing cap bolts is broken or deformed, replace it.

Tightening torque

Main bearing cap bolt

M8 : 13 ~ 19N.m

(130 ~ 190kgf.cm, 10 ~ 14lbf.ft) + 90° ~ 94°

M10 : 27 ~ 33N.m

(270 ~ 330kgf.cm, 19.5 ~ 24lbf.ft) + 90° ~ 94°

5. Install thrust bearings.
Install the 2 thrust bearings (A) under the No.3 journal position of the cylinder block with the oil grooves facing outward.

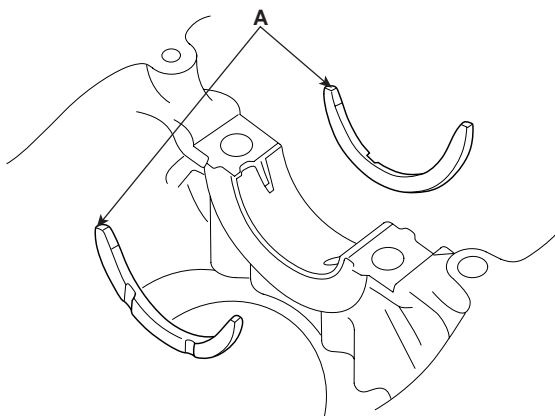

LUIF175A

- 1) Apply a light coat of engine oil on the threads and under the bearing cap bolts.
2) Install and uniformly tighten the 16 bearing cap bolts, in several passes, in the sequence shown.

Tightening torque

M8(A) : 13 ~ 19N.m (130 ~ 190kgf.cm, 10 ~ 14lbf.ft)

M10(B) : 27 ~ 33N.m (270 ~ 330kgf.cm, 19.5 ~ 24lbf.ft)

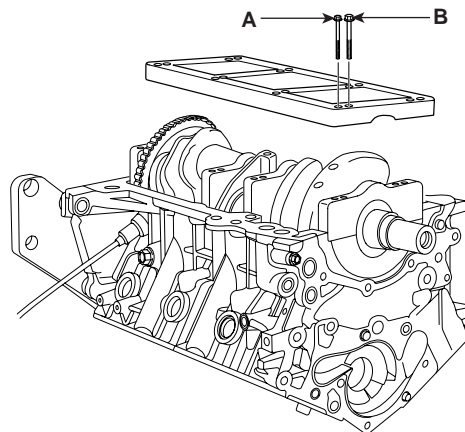

LUIF147A

6. Place crankshaft(A) on the cylinder block.

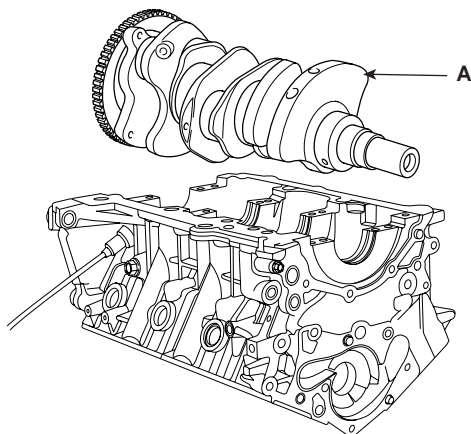

LUIF148A

- 3) Retighten the bearing cap bolts by $90^{\circ} \sim 94^{\circ}$ in the numerical order shown.

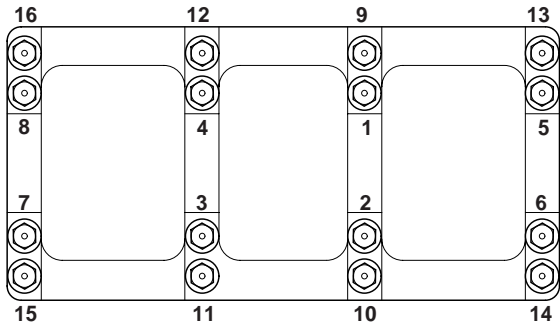

LUIF178A

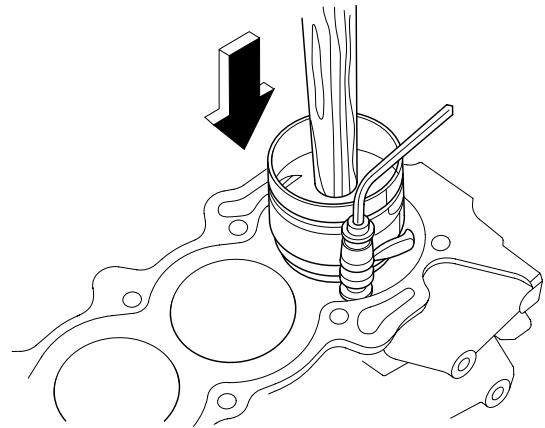

LUIF179A

11. Apply liquid gasket to the oil seal case and install the oil seal case(A).

Tightening torque

10 ~ 12N.m (100 ~ 120kgf.cm, 7.3 ~ 8.8lb.ft)

- 4) Check that the crankshaft turns smoothly.
9. Check crankshaft end play. (See page EMB - 57)
10. Install piston and connecting rod assemblies.

NOTE

Before installing the pistons, apply a coat of engine oil to the ring grooves and cylinder bores.

- 1) Remove the connecting rod caps, and slip short sections of rubber hose over the threaded ends of the connecting rod bolts.
- 2) Install the ring compressor, check that the bearing is securely in place, then position the piston in the cylinder, and tap it in using the wooden handle of a hammer.
- 3) Stop after the ring compressor pops free, and check the connecting rod-to-check journal alignment before pushing the piston into place.
- 4) Apply engine oil to the bolt threads. Install the rod caps with bearings, and torque the bolts.

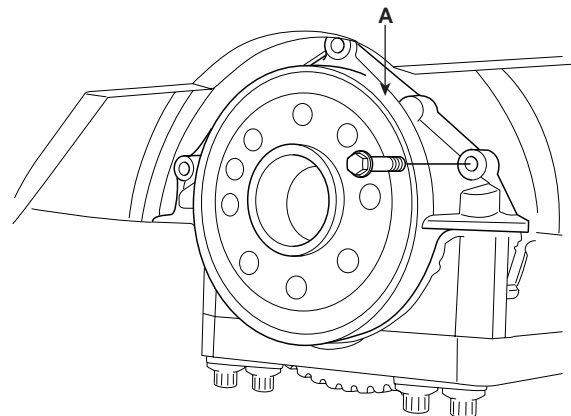

LUIF180A

NOTE

- Use liquid gasket MS721-40A or equivalent
- Check that the mating surfaces are clean and dry.

Tightening torque

16 ~ 20N.m (160 ~ 200kgf.cm, 12 ~ 15lb.ft) + $90^{\circ} \sim 94^{\circ}$

NOTE

Maintain downward force on the ring compressor to prevent the rings from expanding before entering the cylinder bore.

12. Install rear oil seal.

- 1) Apply engine oil to a new oil seal lip.
- 2) Using SST(09231-33000) and a hammer, tap in the oil seal until its surface is flush with the rear oil seal retainer edge.

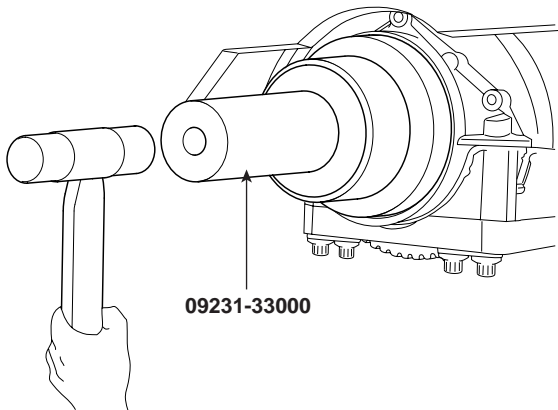

LUIF181A

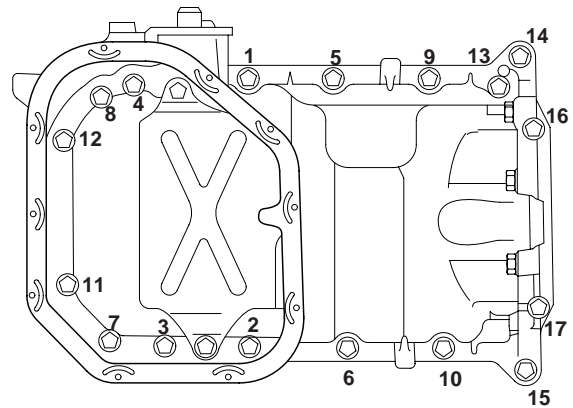

LUIF183A

NOTE

- To prevent leakage of oil, apply liquid gasket to the inner threads of the bolt holes.
- Do not install the parts if five minutes or more have elapsed since applying the liquid gasket. Instead, reapply liquid gasket after removing the residue.
- After assembly, wait at least 30 minutes before filling the engine with oil.

13. Install front case. (See page EMB - 83)

14. Install the upper oil pan.

- 1) Using a razor blade and gasket scraper, remove all the old packing material from the gasket surfaces.

NOTE

Check that the mating surfaces are clean and dry before applying liquid gasket.

- 2) Install the oil pan(A) with the 17bolts. Uniformly tighten the bolts in several passes.

15. Install oil screen.

Install a new gasket and oil screen(A) with 2bolts(B).

Tightening torque

15 ~ 22N.m (150 ~ 220kgf.cm, 11 ~ 16lbf.ft)

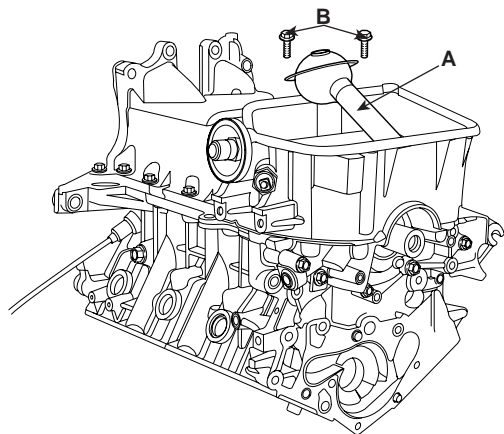

LUIF144A

Tightening torque

19 ~ 28N.m (190 ~ 280kgf.cm, 14 ~ 20lbf.ft) : (1 ~ 15)

5 ~ 7N.m (50 ~ 70kgf.cm, 4 ~ 5lbf.ft) : (16,17)

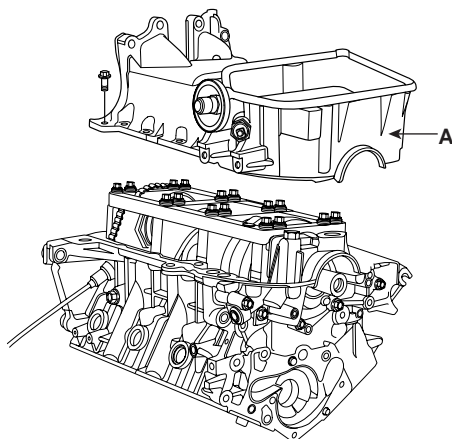

LUIF145A

16. Install the lower oil pan.

- 1) Apply liquid gasket as an even bead, centered between the edges of the mating surface.
Use liquid gasket MS 721-40A or equivalent.

NOTE

- To prevent leakage of oil, apply liquid gasket to the inner threads of the bolt holes.
- Do not install the parts if five minutes or more have elapsed since applying the liquid gasket. Instead, reapply liquid gasket after removing the residue.
- After assembly, wait at least 30 minutes before filling the engine with oil.

- 2) Install the lower oil pan 10bolts.
Uniformly tighten the bolts several passes

Tightening torque

10 ~12N.m (100 ~ 120kgf.cm, 7.3 ~ 8.8lb.ft)

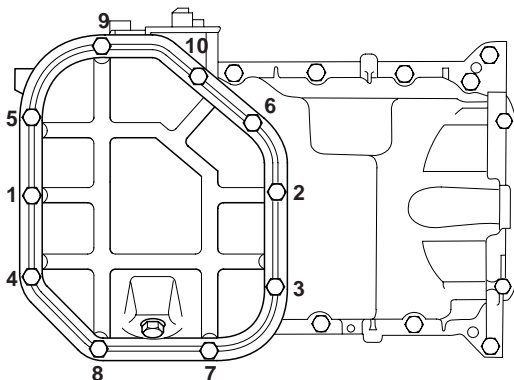

LUIF185A

17. Install oil pressure sensor.

- 1) Apply adhesive to 2 or 3 threads.
Adhesive : THREE BOND TB2403 or equivalent.

2) Install the oil pressure sensor(A).

Tightening torque

15 ~ 22N.m (150 ~ 220kgf.cm, 11 ~ 16lb.ft)

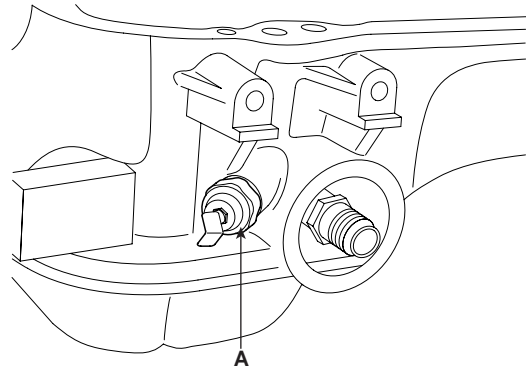

LUIF186A

18. Install knock sensor(A).

Tightening torque

17 ~ 26N.m (170 ~ 260kgf.cm, 12.5 ~ 19lb.ft)

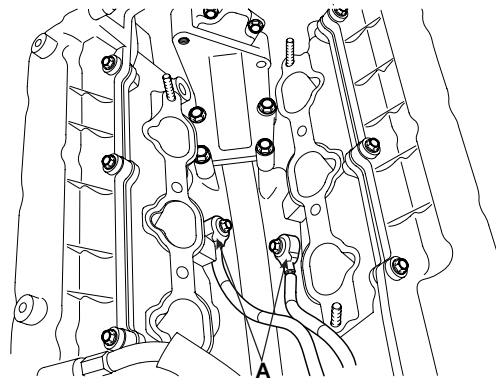

LUIF142A

19. Install water pump. (See page EMB - 75)

20. Install the power steering pump bracket(A).

Tightening torque

35 ~ 55N.m (350 ~ 550kgf.cm, 25.8 ~ 40.6lbf.ft)

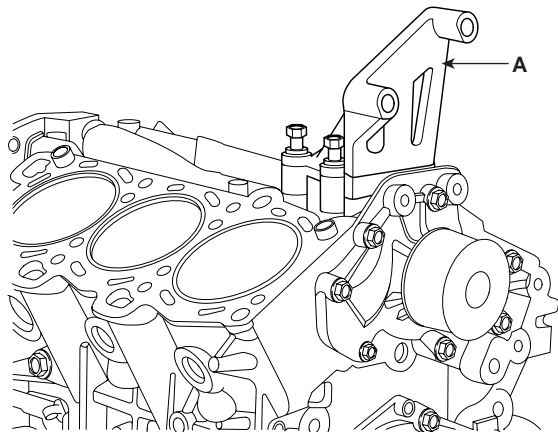

LUIF141A

21. Install the air compressor. (See HA group - air compressor)

22. Install the alternator. (See EE group - alternator)

23. Install oil level gauge assembly.

- 1) Install a new O-ring on the oil level gauge.
- 2) Apply engine oil on the O-ring.
- 3) Install the oil level gauge assembly (A) with the bolt.

Tightening torque

12 ~ 15N.m (120 ~ 150kgf.cm, 9 ~ 11lbf.ft)

24. Install cylinder head. (See page EMB - 35)

25. Install timing belt. (See page EMB - 17)

26. Remove engine stand.

27. Install drive plate.

Tightening torque

73 ~ 77N.m (730 ~ 770kgf.cm, 53 ~ 56lbf.ft)

COOLING SYSTEM

COMPONENT EBF7E365

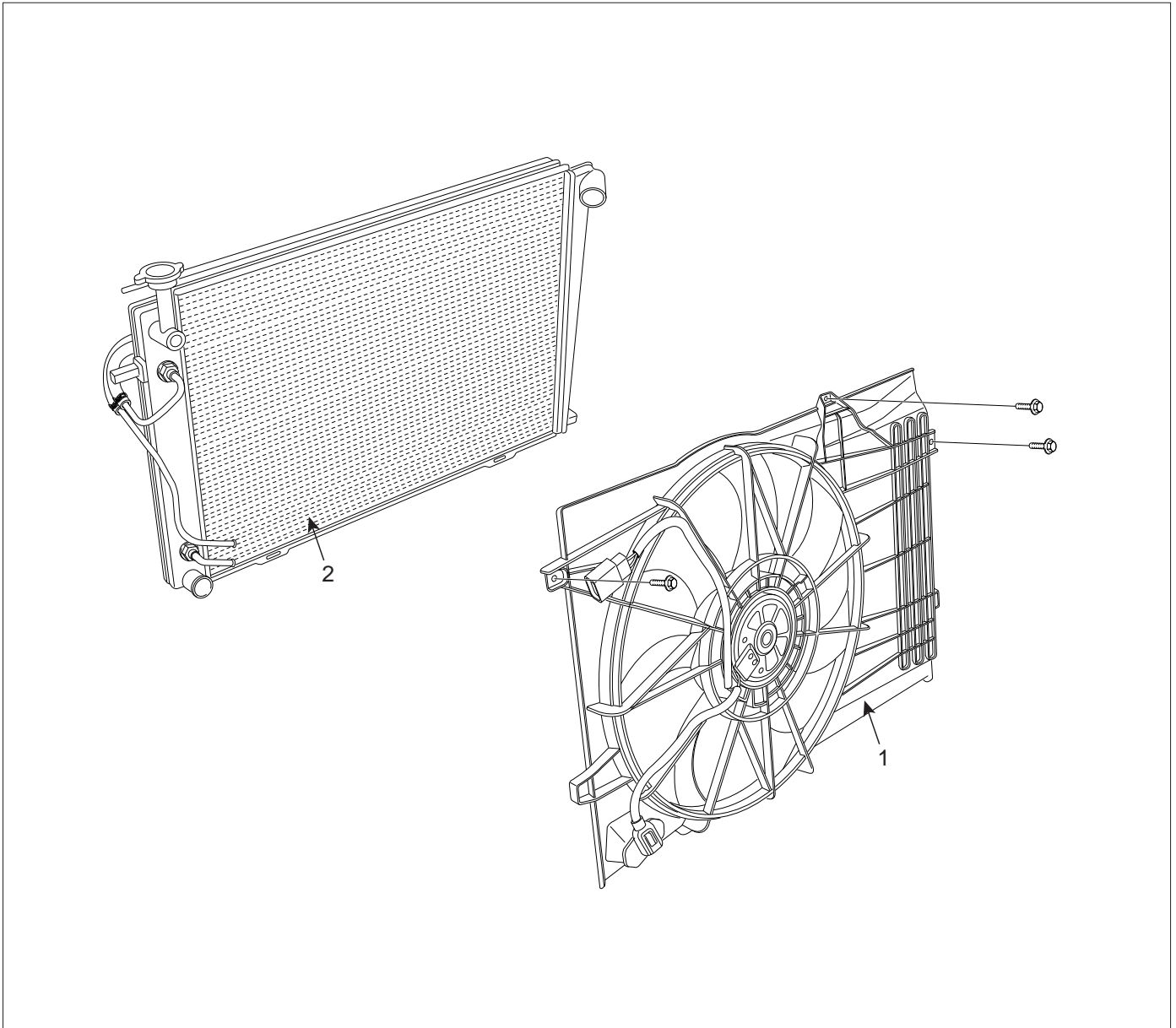

1. Cooling fan & Condenser fan assembly

2. Radiator

LUIF189A

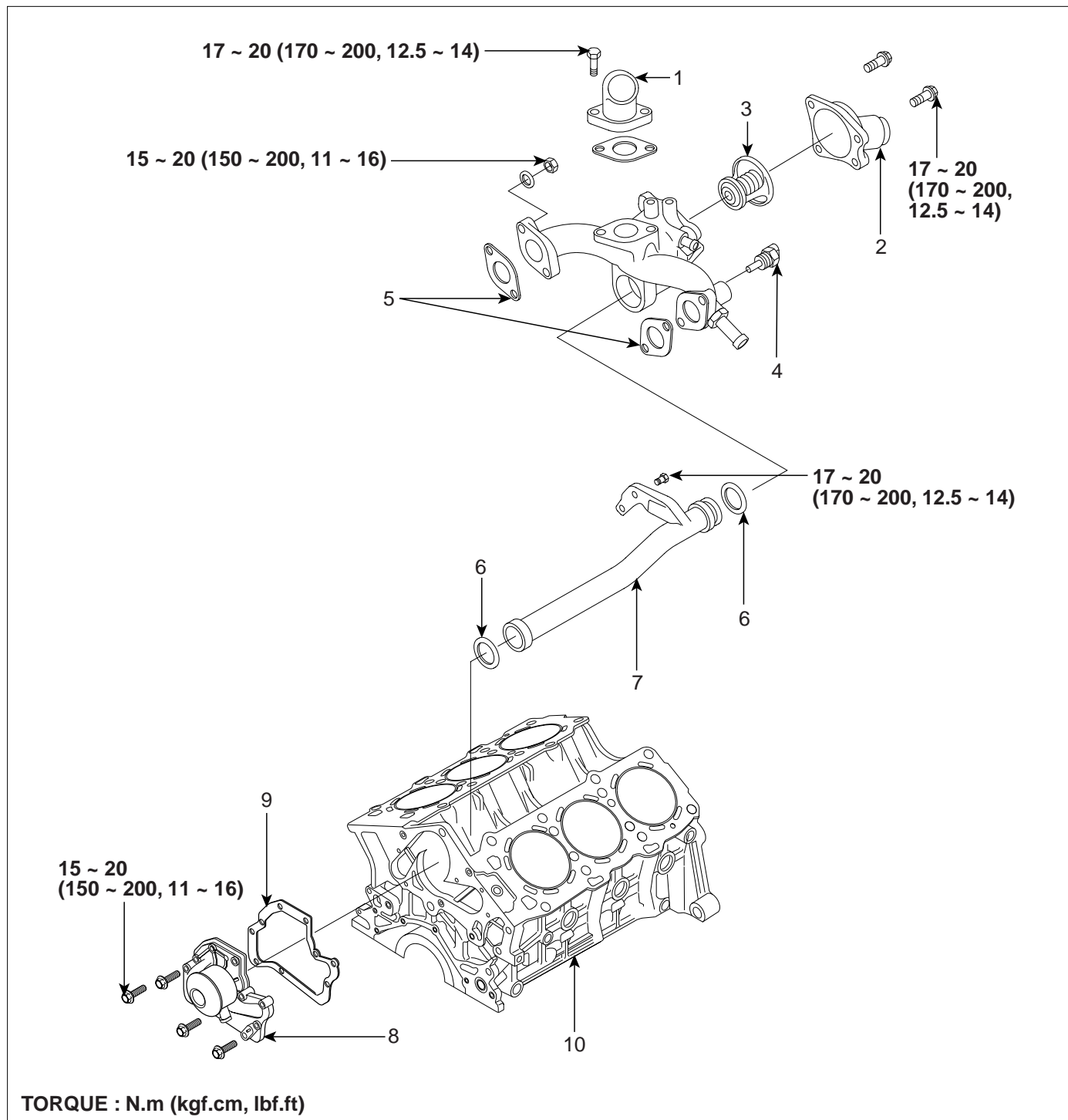

- 1. Water outlet pipe
- 2. Water inlet pipe
- 3. Thermostat
- 4. Engine coolant sensor
- 5. Gasket

- 6. O-ring
- 7. Water pipe
- 8. Water pump
- 9. Water pump gasket
- 10. Cylinder block

ENGINE COOLANT REFILLING AND BLEEDING

EE224F0A

WARNING

Never remove the radiator cap when the engine is hot. Serious scalding could be caused by hot fluid under high pressure escaping from the radiator.

CAUTION

When pouring engine coolant, be sure to shut the relay box lid and not to let coolant spill on the electrical parts or the paint. If any coolant spills, rinse it off immediately.

1. Slide the heater temperature control lever to maximum heat. Make sure the engine and radiator are cool to the touch.
2. Remove radiator cap.
3. Loosen the drain plug, and drain the coolant.

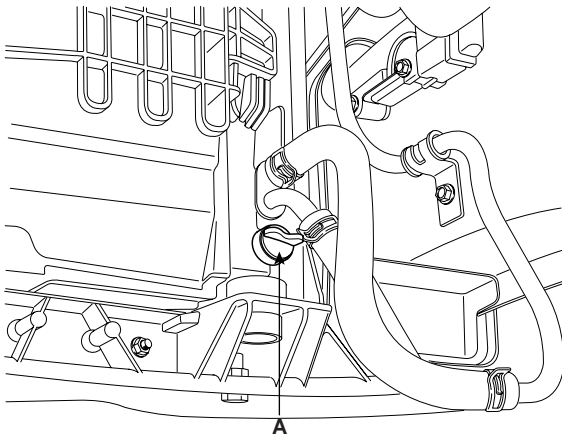

LUIF108A

4. Tighten the radiator drain plug(A) securely.
5. Remove, drain and reinstall the reservoir. Fill the tank halfway to the MAX mark with water, then up to the MAX mark with antifreeze.
6. Fill fluid mixture with coolant and water(4 : 6) slowly through the radiator cap. Push the upper/lower hoses of the radiator so as bleed air easily.

NOTE

- Use only genuine antifreeze/coolant.
- For best corrosion protection, the coolant concentration must be maintained year-round at 50% minimum. Coolant concentrations less than 50% may not provide sufficient protection against corrosion or freezing.

- Coolant concentrations greater than 60% will impair cooling efficiency and are not recommended.

CAUTION

- Do not mix different brands of antifreeze/coolants.
- Do not use additional rust inhibitors or anti-rust products; they may not be compatible with the coolant.

7. Start the engine and run coolant circulates. When the cooling fan operates and coolant circulates, refill coolant through the radiator cap.
8. Repeat 7 until the cooling fan 3 ~ 5times and bleed air sufficiently out of the cooling system.
9. Install the radiator cap and fill the reservoir tank to the "MAX" line with coolant.
10. Run the vehicle under idle until the cooling fan operates 2 ~ 3 times.
11. Stop the engine and wait coolant gets cool.
12. Repeat 6 to 11 until the coolant level doesn't fall any more, bleed air out of the cooling system.

NOTE

As it is to bleed air out to the cooling system and refill coolant when coolant gets cool completely, recheck the coolant level in the reservoir tank for 2 ~ 3 days after replacing coolant.

CAP TESTING

1. Remove the radiator cap, wet its seal with engine coolant, then install it no pressure tester.

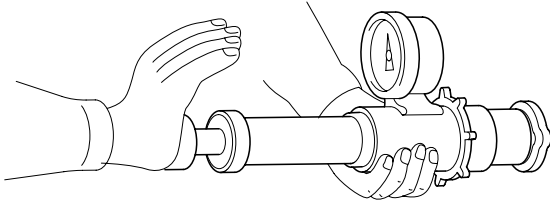

LUIF192A

2. Apply a pressure of 93 ~ 123kPa (0.95 ~ 1.25kgf/cm², 14 ~ 19psi)
3. Check for a drop in pressure.
4. If the pressure drops, replace the cap.

TESTING

1. Wait until engine is cool, then carefully remove the radiator cap and fill the radiator with engine coolant, then install it on the pressure tester.
2. Apply a pressure tester to the radiator and apply a pressure of 93 ~ 123kPa (0.95 ~ 1.25kgf/cm² 14 ~ 19psi).

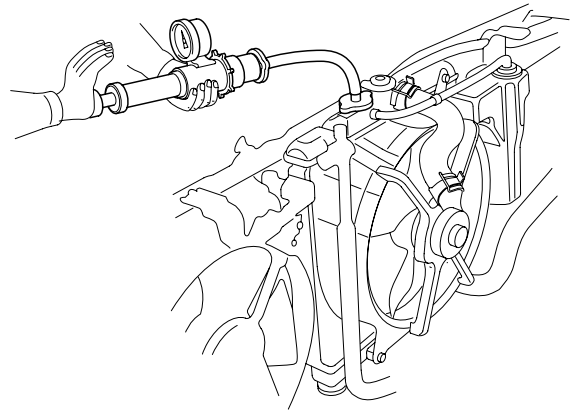

LUIF193A

3. Inspect for engine coolant leaks and a drop in pressure.
4. Remove the tester and reinstall the radiator cap.

 **NOTE**

Check for engine oil in the coolant and/or coolant in the engine oil.

REMOVAL E237D66A

WATER PUMP

1. Drain the engine coolant.

⊗ WARNING

System is under high pressure when the engine is hot. To avoid danger of releasing scalding engine coolant, remove the cap only when the engine is cool.

2. Remove drive belts. (See page EMB - 14)
3. Remove the timing belt. (See page EMB - 14)
4. Remove the timing belt idler. (See page EMB - 16)
5. Remove the water pump.
Remove the water pump(A) and gasket(B).

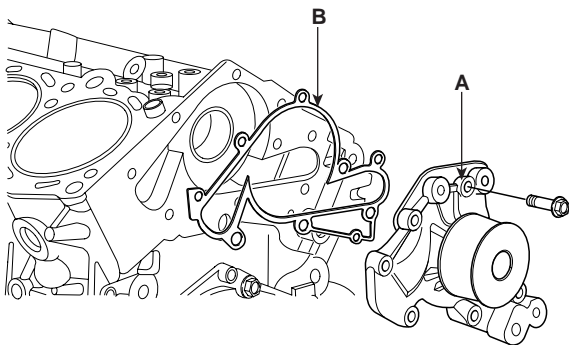

LUIF194A

THERMOSTAT

NOTE

Removal of the thermostat would have an adverse effect, causing a lowering of cooling efficiency. Do not remove the thermostat, even if the engine tends to overheat.

1. Remove the engine cover.
2. Drain engine coolant so its level is below thermostat.
3. Remove the lower hose.
4. Remove water inlet(A) and thermostat(B).

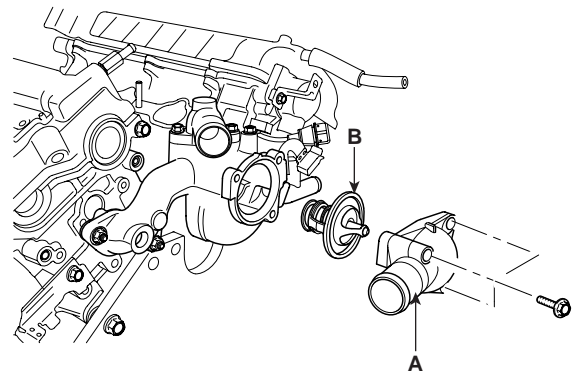

LUIF195A

COOLING SYSTEM

EMB -73

RADIATOR

1. Remove the under cover(A).

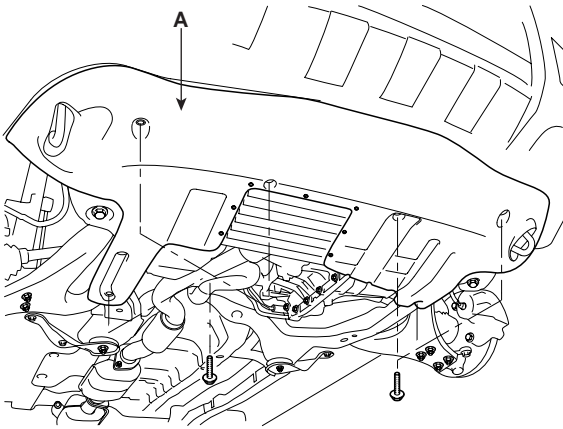

LDIF013A

2. Drain the engine coolant. Remove the radiator cap to speed draining.

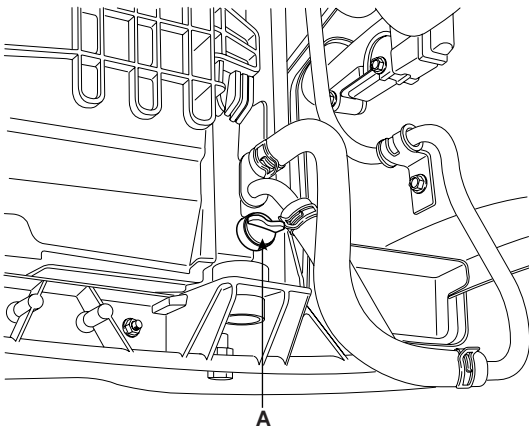

LDIF023A

3. Remove the air duct(A).

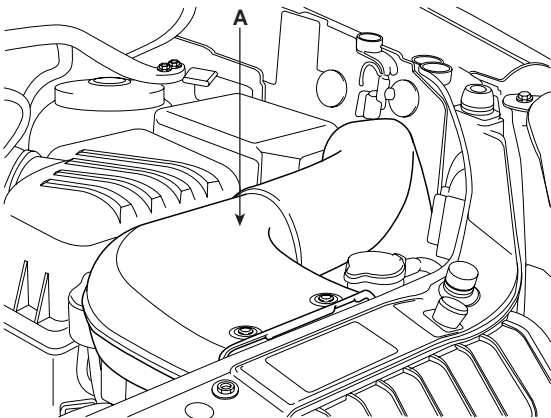

LDIF003A

4. Remove the battery and tray.

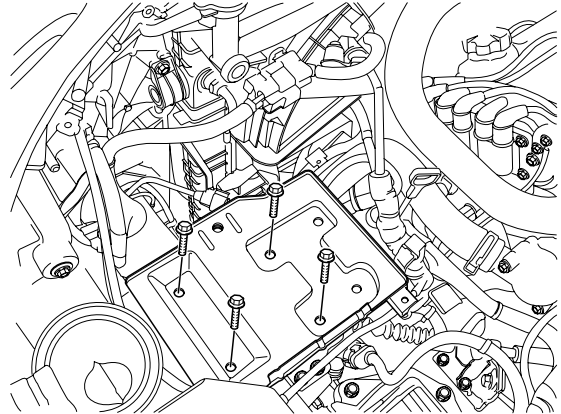

LDIF010A

5. Remove the coolant reservoir tank(A).

6. Remove the radiator upper hose(B).

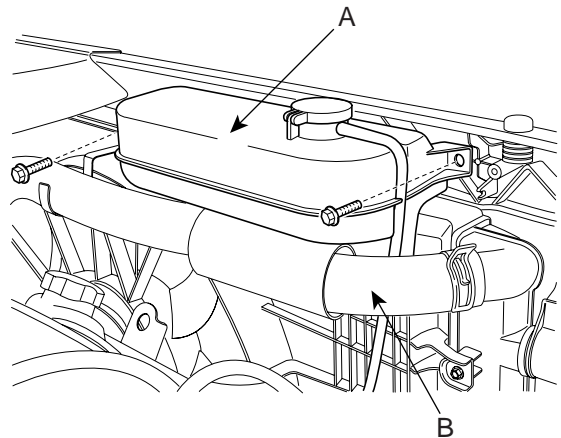

ADIE014A

7. Remove the radiator lower hose(A).

8. Remove the ATF oil cooler hose(B).

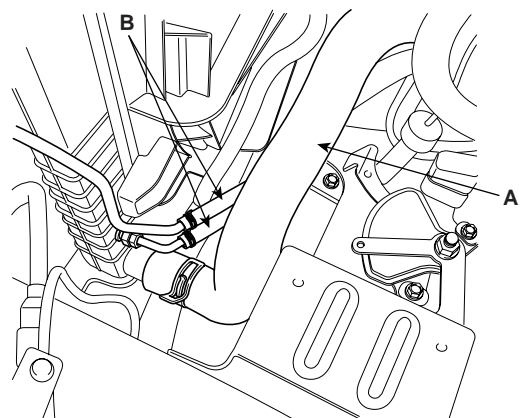

ACIE180A

EMB -74

ENGINE (G6BA - GASOLINE 2.7)

- 9. Remove the cooling fan motor connector(A).
- 10. Remove the cooling fan motor assembly mounting bolt(B).
- 11. Remove the ATF oil cooler pipe(C).

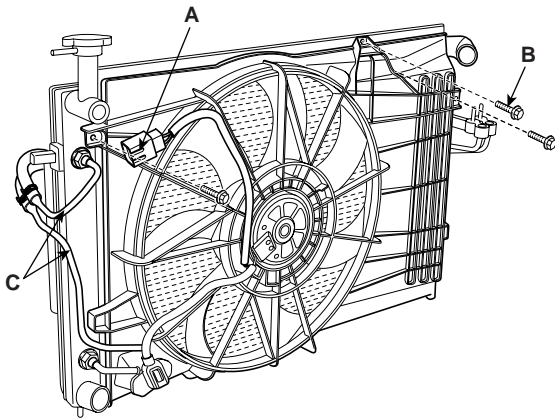

ACIE181A

- 14. Remove the condenser mounting bolt(A).
- 15. Remove the condenser bracket(B) with pulling the condenser from the radiator.

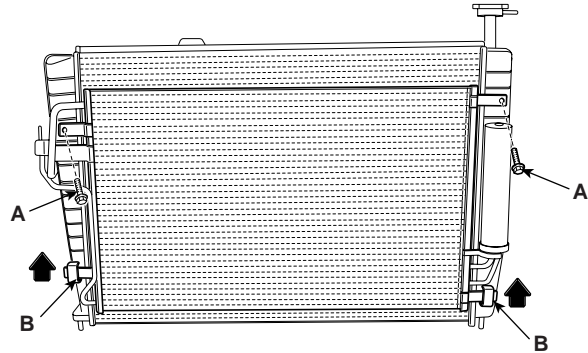

ACIE184A

- 12. Remove the cooling fan motor assembly with pulling it from the radiator.
- 13. Remove the radiator bracket(A,B).

- 16. Remove the radiator from engine room.

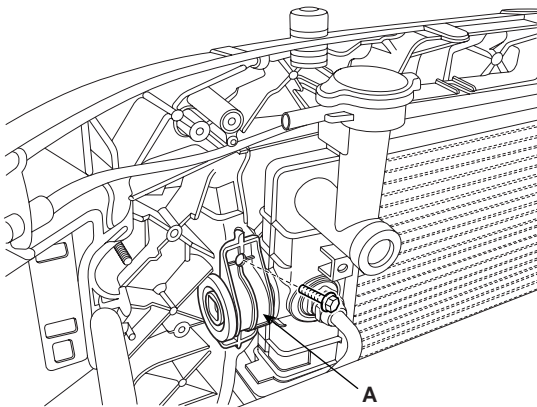

ACIE182A

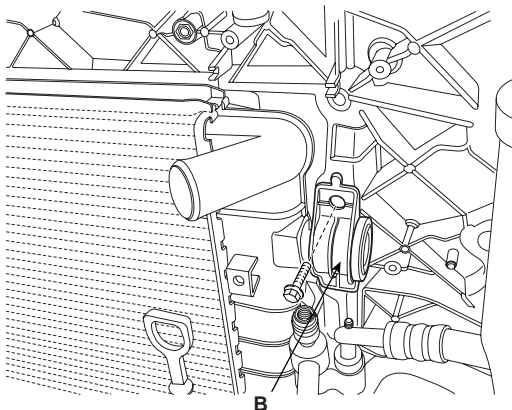

ACIE183A

COOLING SYSTEM

EMB -75

INSPECTION ED2DAC08

WATER PUMP

1. Check each part for cracks, damage or wear, and replace the coolant pump assembly if necessary.
2. Check the bearing for damage, abnormal noise and sluggish rotation, and replace the coolant pump assembly if necessary.
3. Check for coolant leakage. If coolant leaks from hole, the seal is defective. Replace the coolant pump assembly

NOTE

A small amount of “ weeping” from the bleed hole is normal.

THERMOSTAT

1. Immerse the thermostat in water and gradually heat the water.

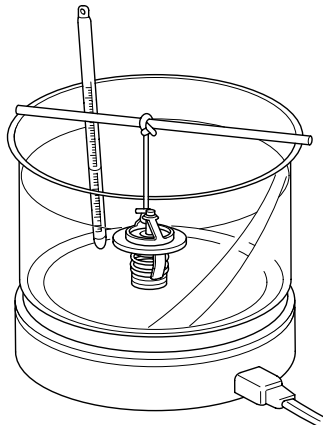

LUIF196A

2. Check the valve opening temperature.

Valve opening temperature : 82 (177)
 Full opening temperature : 95 (205)

If the valve opening temperature is not as specified, replace the thermostat.

3. Check the valve lift.

Valve lift : 8mm(0.3in.) or more at 95 (205)

If the valve lift is not as specified, replace the thermostat.

INSTALLATION EC5FFAA2

WATER PUMP

1. Install the water pump(A) and a new gasket(B) with the 8bolts.

Tightening torque

15 ~ 22N.m (150 ~ 220kgf.cm, 11 ~ 16lb.ft)

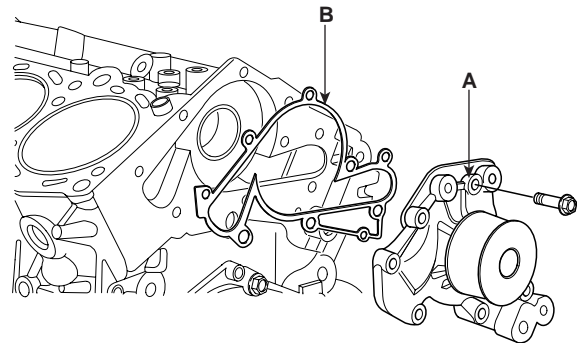

LUIF194A

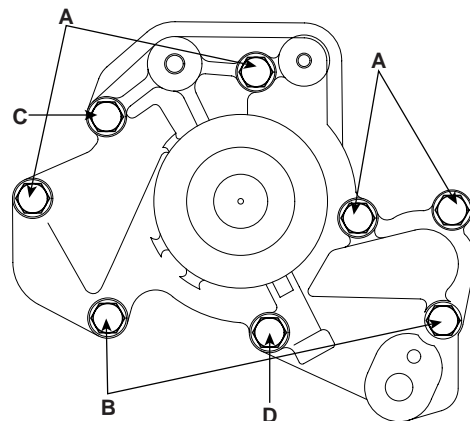

LUIF198A

Bolt	Size	Number
A	8 × 25	4
B	8 × 30	2
C	8 × 32	1
D	8 × 40	1

EMB -76

ENGINE (G6BA - GASOLINE 2.7)

2. Install the timing belt idler. (See page EMB - 17)
3. Install the timing belt. (See page EMB - 17)
4. Install drive belt.
5. Fill with engine coolant. (See page EMB - 70)
6. Start engine and check for leaks.
7. Recheck engine coolant level.

THERMOSTAT

1. Place thermostat in thermostat housing.
 - 1) Install the thermostat with the jiggle valve upward.
 - 2) Install a new to the thermostat(B).

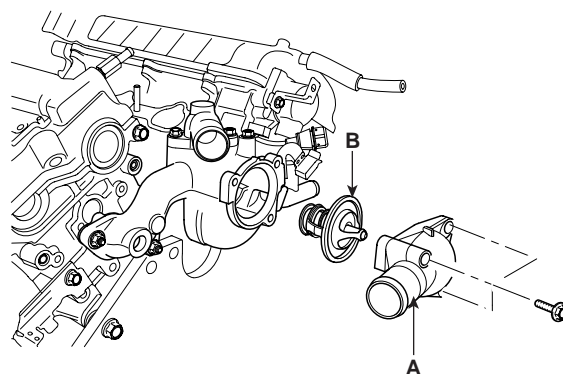

LUIF195A

2. Install water inlet(A).

Tightening torque

17 ~ 20N.m (170 ~ 200kgf.cm, 12.5 ~ 14lbf.ft)

3. Install the lower hose.
4. Fill with engine coolant.
5. Start engine and check for leaks.

LUBRICATION SYSTEM

COMPONENT EEF31427

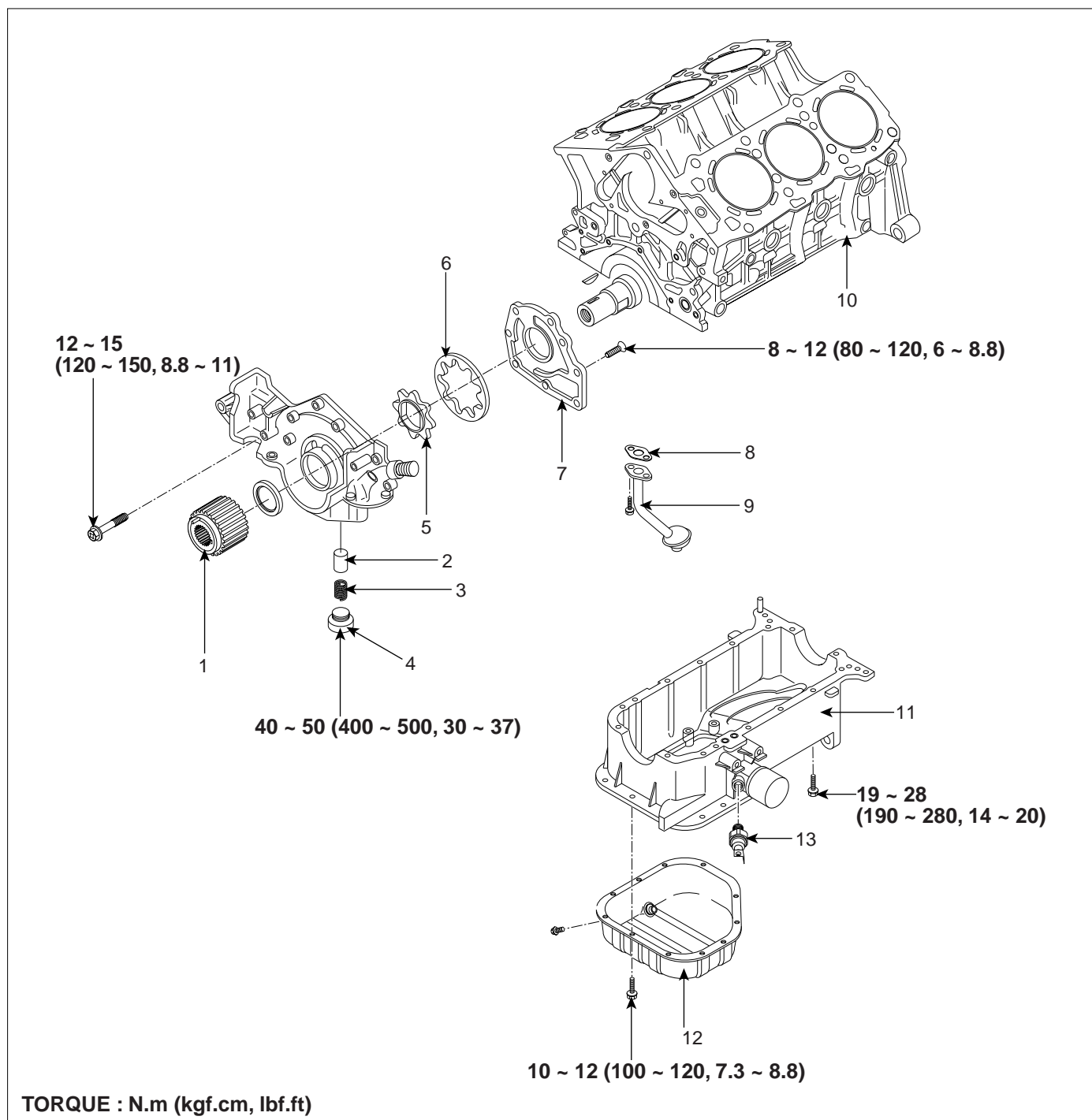

- 1. Crankshaft sprocket
- 2. Relief plunger
- 3. Relief spring
- 4. Plug
- 5. Inner rotor
- 6. Outer rotor
- 7. Oil pump cover

- 8. Gasket
- 9. Oil screen
- 10. Cylinder block
- 11. Upper oil pan
- 12. Lower oil pan
- 13. Oil pressure switch

OIL AND FILTER E551FDDA

 CAUTION

- **Prolonged and repeated contact with mineral oil will result in the removal of natural fats from the skin, leading to dryness, irritation and dermatitis. In addition, used engine oil contains potentially harmful contaminants which may cause skin cancer.**
- **Exercise caution in order to minimize the length and frequency of contact of your skin to used oil. Wear protective clothing and gloves. Wash your skin thoroughly with soap and water, or use water-less hand cleaner, to remove any used engine oil. Do not use gasoline, thinners, or solvents.**
- **In order to preserve the environment, used oil and used oil filter must be disposed of only at designated disposal sites.**

1. Drain engine oil.
 - a. Remove the oil filter cap.
 - b. Remove the oil drain plug(A), and drain the oil into a container.

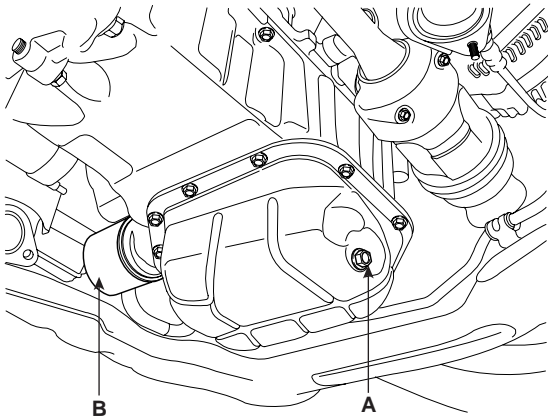

LUIF201A

2. Replace oil filter.
 - a. Remove the oil filter(B).
 - b. Check and clean the oil filter installation surface.
 - c. Check the part number of the new oil filter is as same as old one.
 - d. Apply clean engine oil to the gasket of a new oil filter.
 - e. Lightly screw the oil filter into place, and tighten it until the gasket contacts the seat.
 - f. Tighten it an additional 3/4 turn.

3. Refill with engine oil filter.
 - Clean and install the oil drain plug with a new gasket.

Tightening torque

35 ~ 45N.m (350 ~ 450kgf.cm, 26 ~ 33lb.ft)

- Fill with fresh engine oil

Capacity

Drain and refill

W/Oil filter change : 4.5l (4.74U.S.qts, 3.95Imp qts)

W/O Oil filter change : 4.2l (4.30U.S.qts, 3.65Imp qts)

- Install the oil filter cap.

4. Start engine and check for oil leaks.
5. Recheck engine oil level.

INSPECTION

1. Check engine oil quality
Check the oil for deterioration, entry of water, discoloring or thinning.
If the quality is visibly poor, replace the oil.
2. Check engine oil level.
After warming up the engine and then 5 minutes after the engine stop, oil level should be between the " L " and " F " marks on the dipstick.
If low, check for leakage and add oil up to the " F " mark.

 NOTE

Do not fill with engine oil above the " F " mark.

SELECTION OF ENGINE OIL

Recommended ILSAC classification : GF-3 OR ABOVE

Recommended API classification : SL(SJ) OR ABOVE

RECOMMENDED SAE VISCOSITY GRADES :

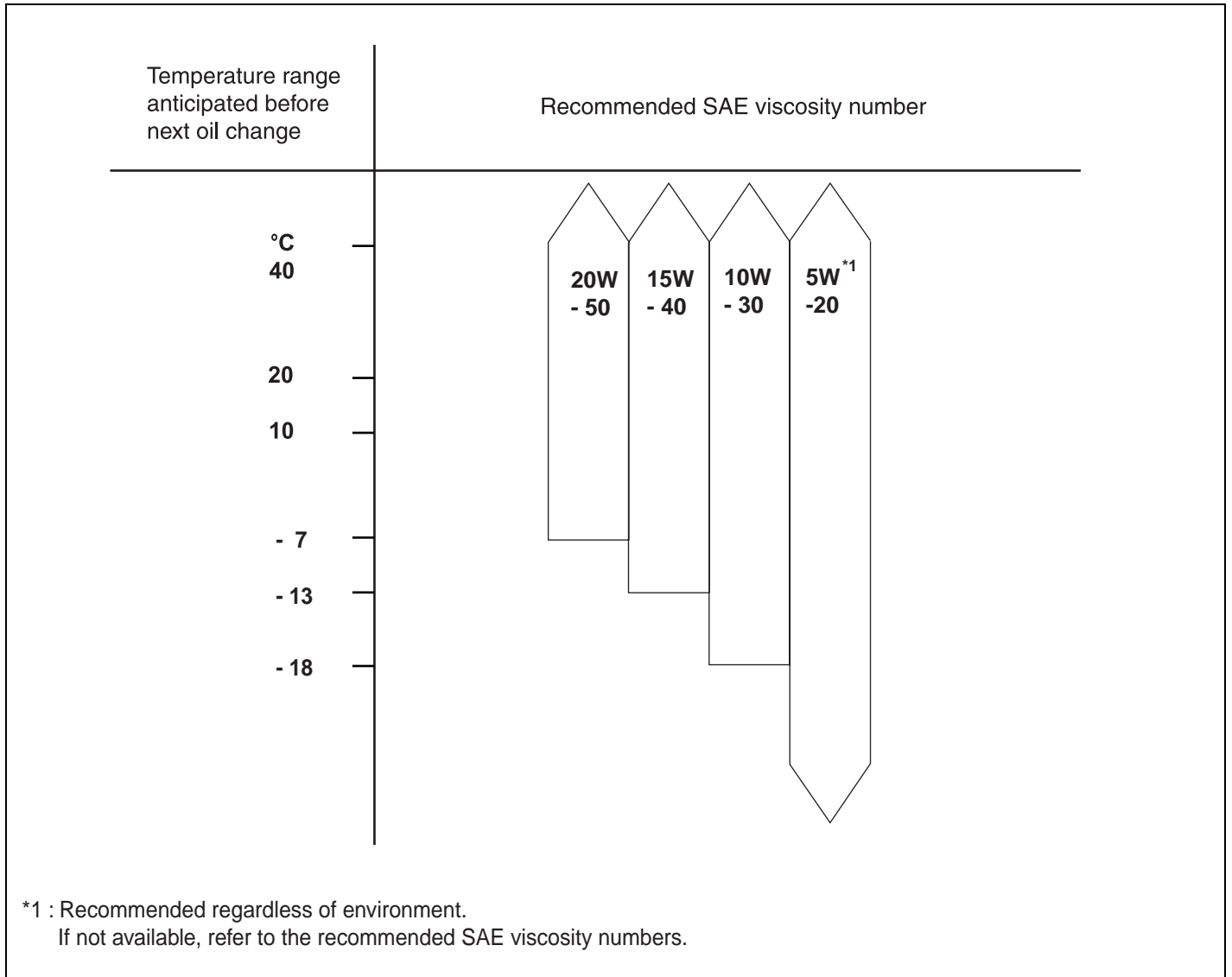

LC8F002A

NOTE

For best performance and maximum protection of all types of operation, select only those lubricants which :

1. Satisfy the requirement of the API classification.
2. Have proper SAE grade number for expected ambient temperature range.
3. Lubricants that do not have both an SAE grade number and API service classification on the container should not be used.

EMB -80

ENGINE (G6BA - GASOLINE 2.7)

REMOVAL E02DFCA0

1. Drain engine oil.
2. Remove RH front wheel.
3. Remove RH side cover.
4. Remove the front exhaust pipe. (See page EMB - 46)
5. Remove the alternator from engine. (See EE group - alternator)
6. Remove the drive belt. (See page EMB - 14)
7. Turn the crankshaft and align the white groove on the crankshaft pulley with the pointer on the lower cover. (See page EMB - 14)
8. Remove the timing belt. (See page EMB - 14)
9. Remove the oil pan and oil screen.(see page EMB - 51)
10. Remove the oil pump case(A).

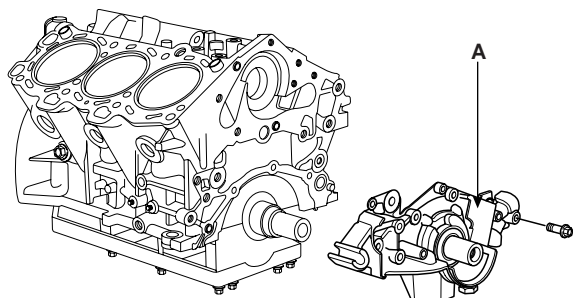

LUIF203A

- 1) Remove the screws(B) from the pump housing, then separate the housing and cover(A).

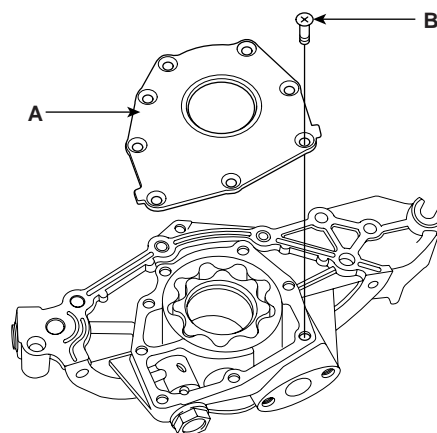

LUIF204A

- 2) Remove the inner and outer rotors.

DISASSEMBLY EAAB73E2

1. Remove the relief plunger.
Remove the plug(A), spring(B) and relief plunger(C).

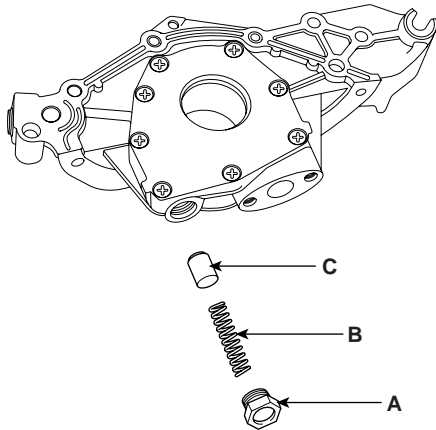

LUIF205A

INSPECTION EA0ADEC5

1. Inspect relief plunger.
Coat the valve with engine oil and check that it falls smoothly into the plunger hole by its own weight. If it does not, replace the relief plunger. If necessary, replace the front case.
2. Inspect relief valve spring.
Inspect for distorted or broken relief valve spring.

Standard value

Free height : 43.8mm (91.724in.)

Load : 4.6kg/39.1mm (10lb/1.547in.)

3. Inspect rotor side clearance.
Using a feeler gauge and precision straight edge, measure the clearance between the rotors and precision straight edge.

Side clearance

0.04 ~ 0.095mm (0.0016 ~ 0.0037in.)

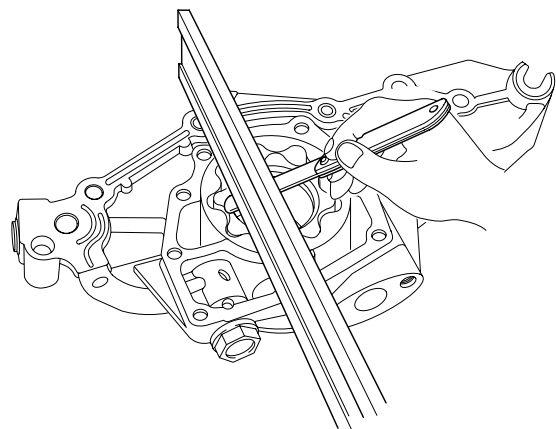

LUIF206A

If the side clearance is greater than maximum, replace the rotors as a set. If necessary, replace the front case.

4. If the tip clearance is greater than maximum, replace the rotor as a set.

EMB -82

ENGINE (G6BA - GASOLINE 2.7)

5. Inspect rotor body clearance.
Using a feeler gauge, measure the clearance between the outer rotor and body.

Body clearance

0.100 ~ 0.181mm (0.0039 ~ 0.0017in.)

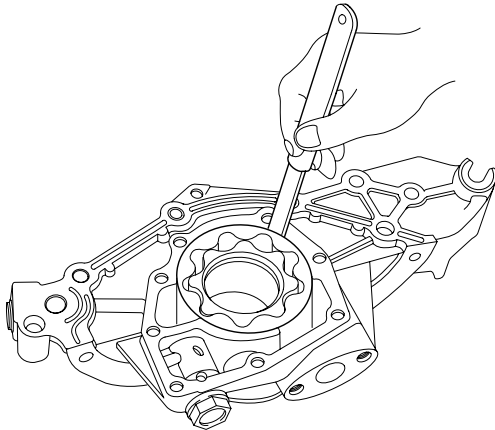

LUIF207A

If the body clearance is greater than maximum, replace the rotors as a set. If necessary, replace the front case.

REASSEMBLY E05D58E6

1. Install relief plunger.
Install relief plunger(C) and spring(B) into the front case hole, and install the plug(A).

Tightening torque

40 ~ 50N.m (400 ~ 500kgf.cm, 30 ~ 37lb.ft)

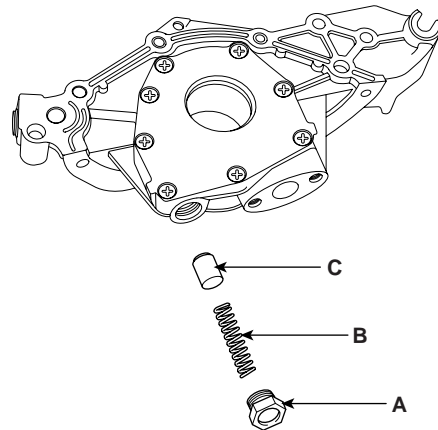

LUIF205A

INSTALLATION E782E76E

1. Install oil pump.
 - 1) Place the inner and outer rotors into front case with the marks facing the oil pump cover side.
 - 2) Install the oil pump cover(A) to front case with the 8screws(B).

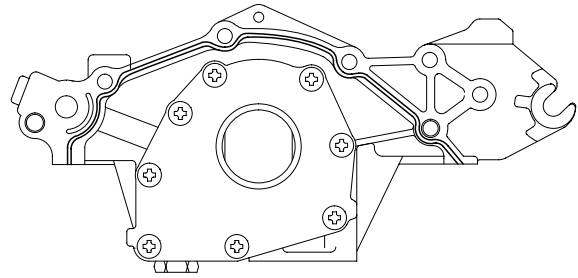

LUIF210A

Tightening torque

8 ~ 12N.m (80 ~ 120kgf.cm, 6 ~ 8.8lbf.ft)

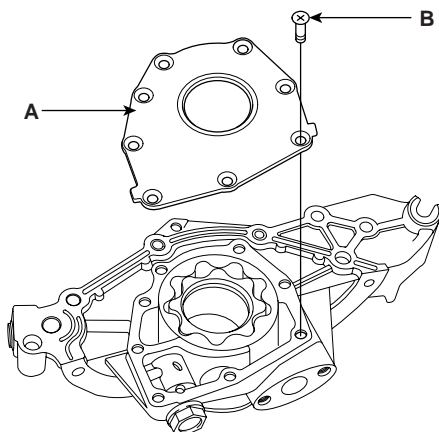

LUIF204A

NOTE

- To prevent leakage of oil, apply liquid gasket to the inner threads of the bolt holes.
- Do not install the parts if five minutes or more have elapsed since applying the liquid gasket. Instead, reapply liquid gasket after removing the residue.
- After assembly, wait at least 30 minutes before filling the engine with oil.

2. Check that the oil pump turns freely.
3. Install the oil pump on the cylinder block.
 - 1) Remove any old liquid gasket and be careful not to drop any oil on the contact surfaces of the oil pump and cylinder block.
 - Using a razor blade and gasket scraper, remove all the old liquid gasket from the gasket surfaces and sealing grooves.
 - Using a non-residue solvent, clean both sealing surfaces.
 - 2) Apply liquid gasket to the oil pump as shown in the illustration. Use liquid gasket MS 721-40A.

- 3) Place a new O-ring on the cylinder block.
- 4) Engage the spline teeth of the oil pump drive gear with large teeth of the crankshaft, and slide the oil pump on the crankshaft.
- 5) Install the oil pump with 5bolts. Uniformly tighten the bolts in several passes.

Tightening torque

12 ~ 15N.m (120 ~ 150kgf.cm, 8.8 ~ 11lbf.ft)

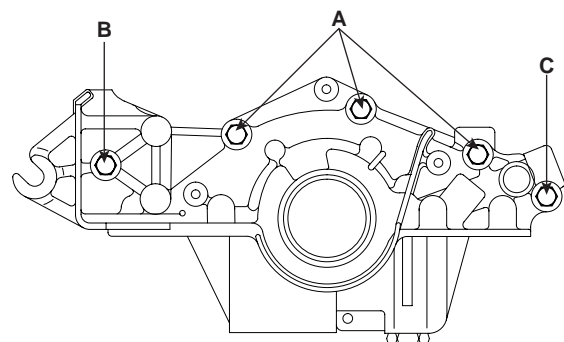

LUIF211A

Bolt	Size	Number
A	8 × 25	3
B	8 × 35	1
C	8 × 45	1

4. Apply a light coat of oil to the seal lip.
5. Using the special tool(09214-33000), install the oil seal.

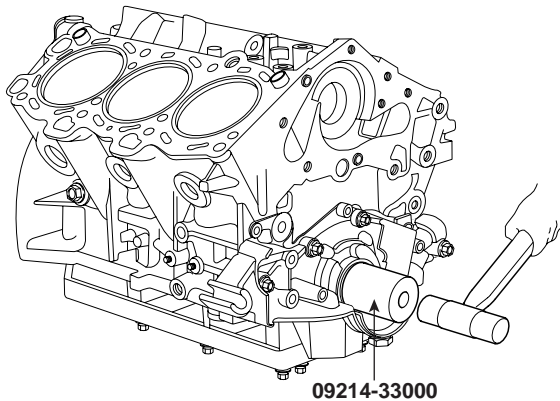

LUIF212A

6. Install the oil pan and oil screen. (See page EMB - 65)
7. Install the timing belt. (See page EMB - 17)
8. Install the drive belt
9. Install the alternator. (See EE group - alternator)
10. Install the front exhaust pipe. (See page EMB - 92)
11. Install the RH front wheel.
12. Fill engine with oil.
13. Start engine and check for leaks.
14. Recheck engine oil level.

INTAKE AND EXHAUST SYSTEM

COMPONENT E5AEBD74

INTAKE MANIFOLD

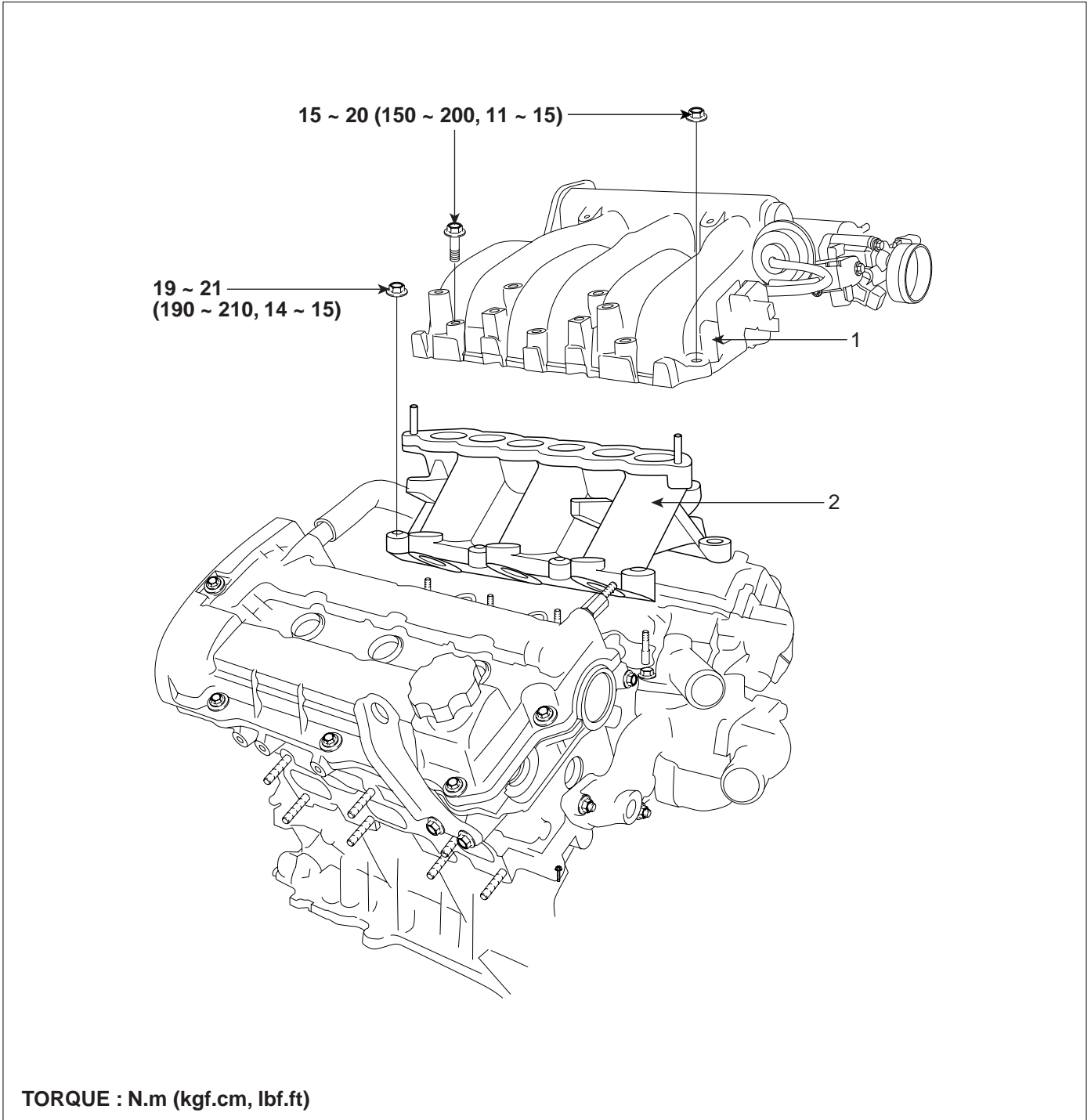

1. Surge tank assembly

2. Intake manifold

LUIF213A

EXHAUST MANIFOLD

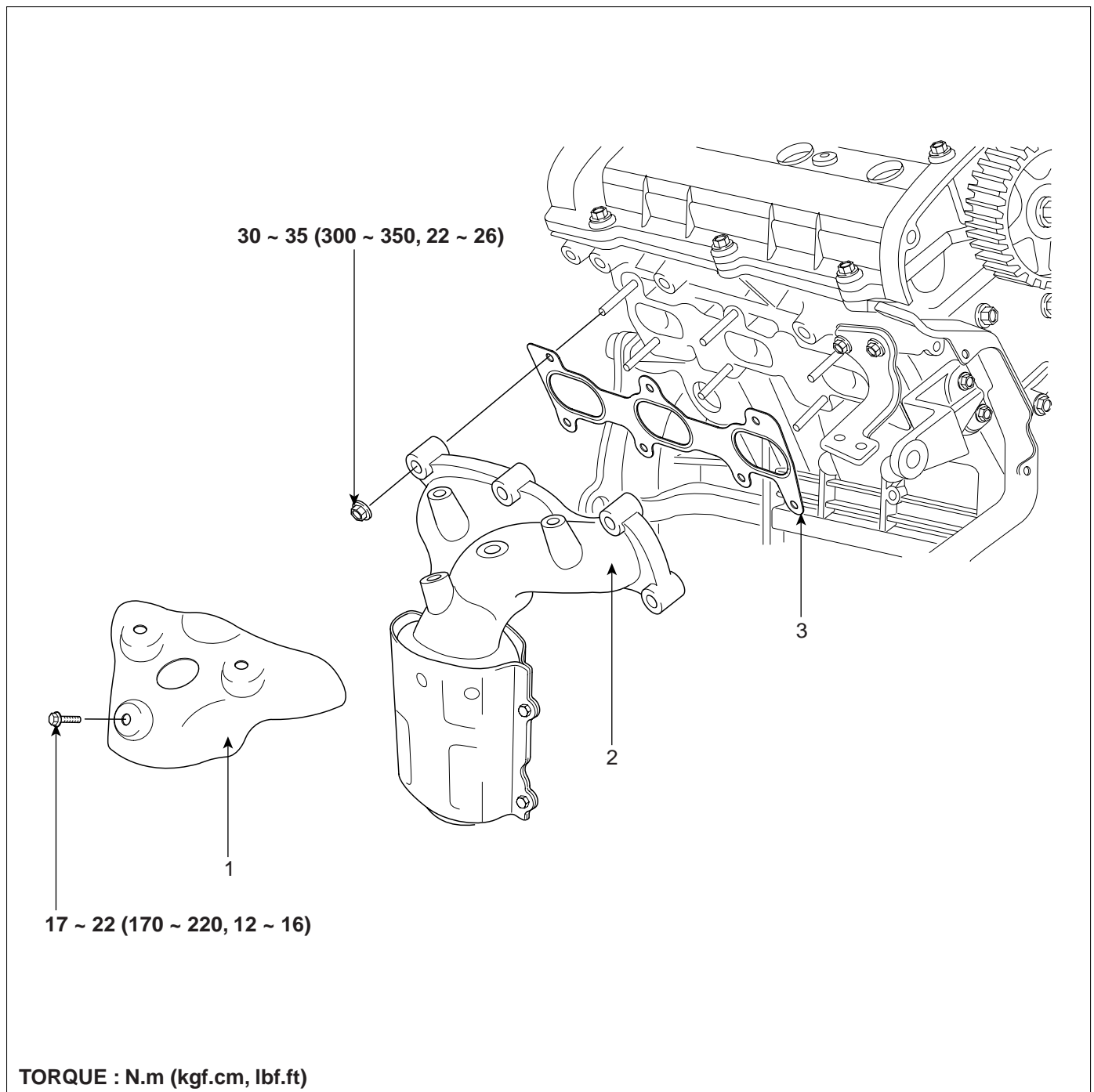

- 1. Heat protector
- 2. Exhaust manifold

- 3. Gasket

LUIF214A

MUFFLER

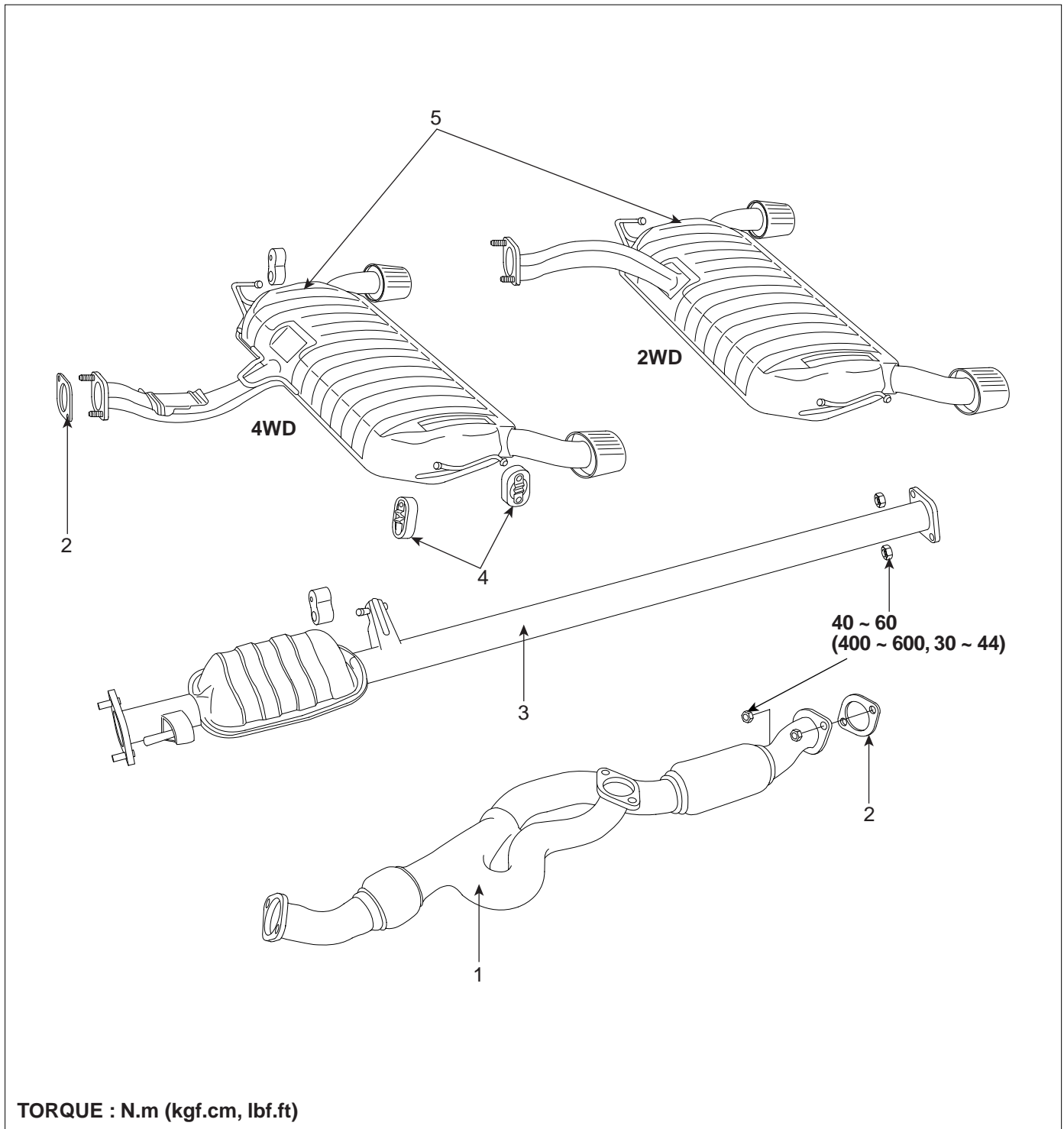

- 1. Front muffler
- 2. Gasket
- 3. Center muffler

- 4. Rubber hanger
- 5. Main muffler

REMOVAL EE9095EF

INTAKE MANIFOLD

1. Remove the engine cover.
2. Remove air cleaner hose.
3. Remove surge tank assembly.
 - 1) Disconnect the accelerator cable.

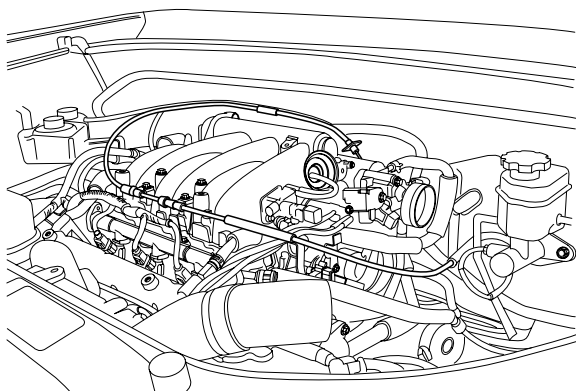

LUIF092A

- 2) Disconnect the TPS connector(A).
- 3) Disconnect the ISA connector(B).
- 4) Disconnect the VIS actuator connector(C).
- 5) Disconnect the injector connector(D).
- 6) Disconnect the PCSV connector(E).

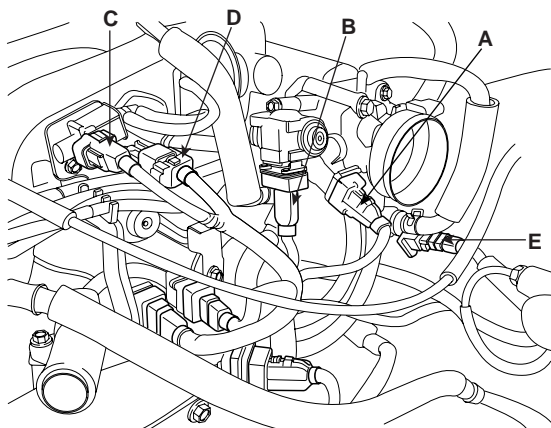

LUIF217A

- 7) Disconnect the PCSV hose.
- 8) Disconnect the brake booster vacuum hose(A).

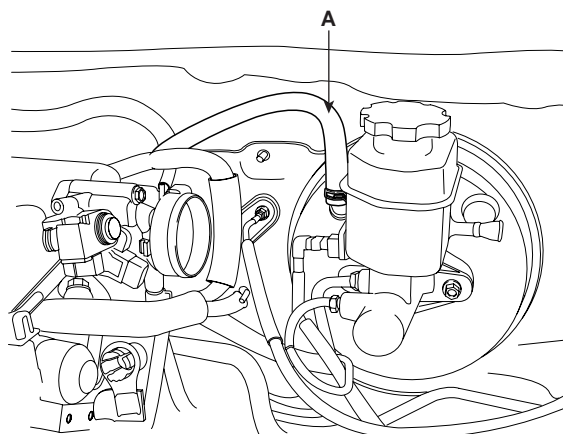

LUIF093A

- 9) Disconnect the PCV hose.
- 10) Disconnect the IAT sensor connector(A).
- 11) Disconnect the VIS actuator connector(B).

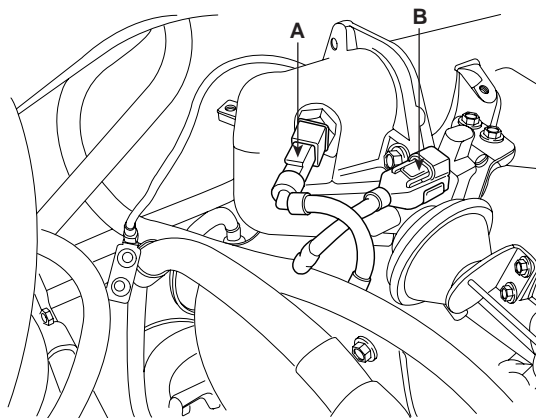

LUIF219A

- 12) Disconnect the ground cable(A) from the surge tank assembly.

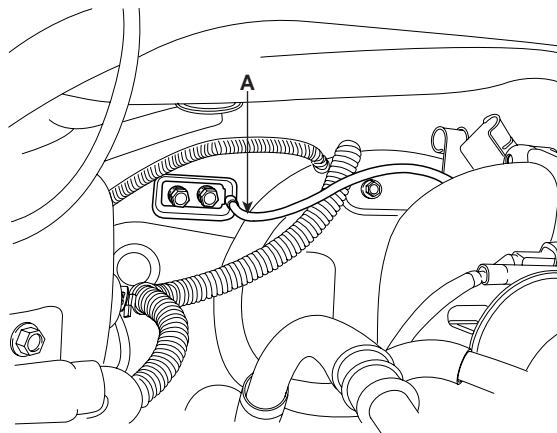

LUIF095A

INTAKE AND EXHAUST SYSTEM

13) Remove the surge tank stay.

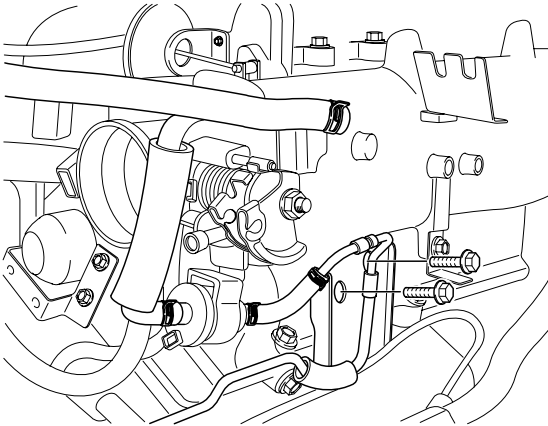

LUIF221A

4. Remove the injector assembly(A).

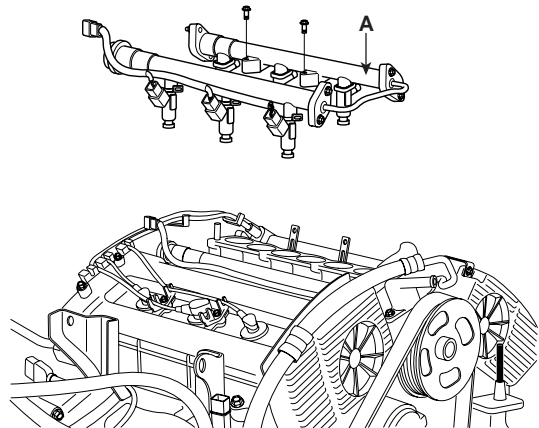

LUIF224A

5. Remove the intake manifold(A) and gasket.

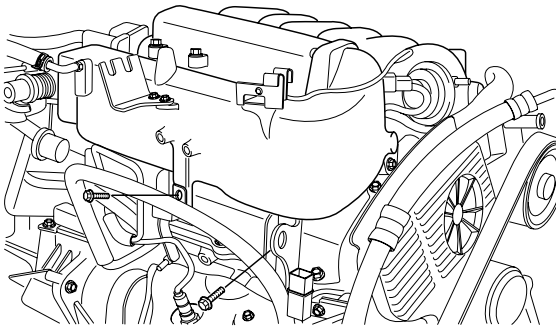

LUIF222A

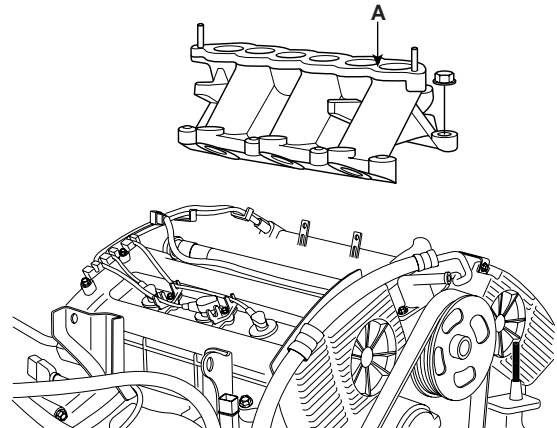

LUIF225A

14) Remove the surge tank assembly(A).

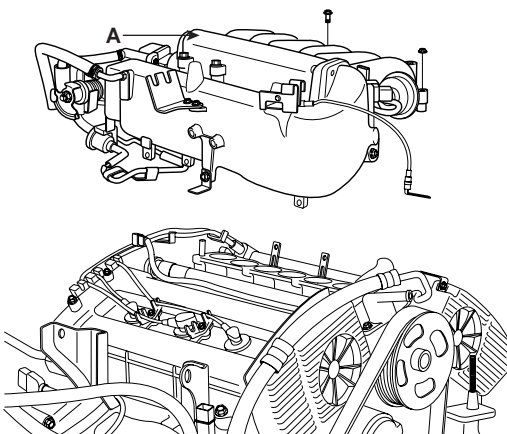

LUIF223A

EMB -90

ENGINE (G6BA - GASOLINE 2.7)

EXHAUST MANIFOLD

1. Remove the under cover(A).

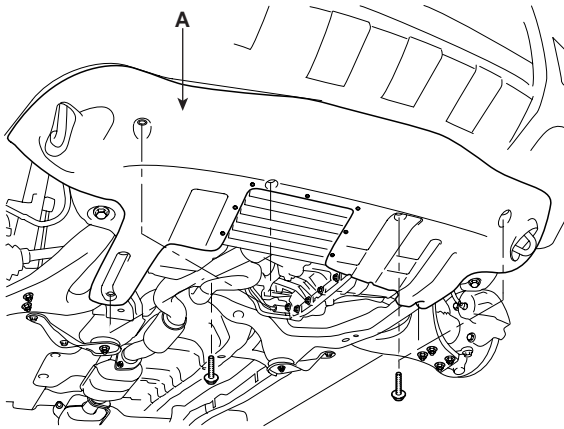

LUIF128A

2. Remove the front exhaust pipe(A).

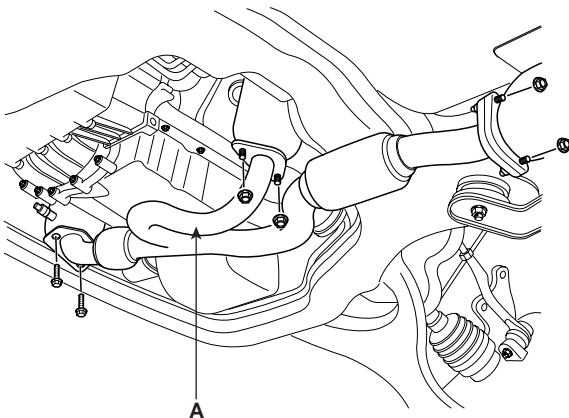

LUIF129A

3. Disconnect the oxygen sensor connector.
4. Remove the cooling fan motor assembly. (Refer to EMB - 73)
5. Remove the Air conditioner compressor. (Refer to HA Gr.)
6. Remove the LH heat protector(A).

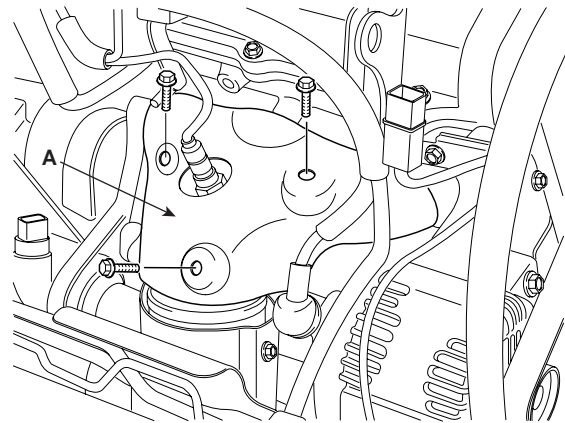

LUIF228A

7. Remove the LH exhaust manifold(A) and gasket(B).

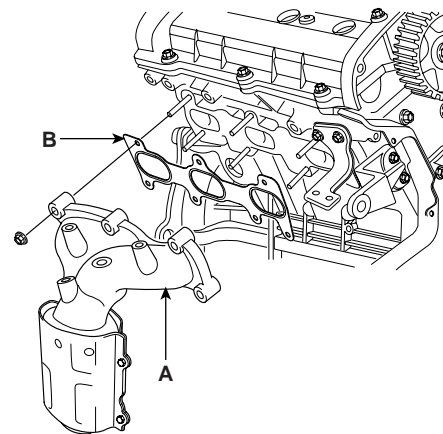

LUIF229A

8. Remove the alternator. (Refer to EE Gr.)
9. Remove the RH drive shaft. (Refer to DS Gr.)
10. Remove the RH heat protector.
11. Remove the RH exhaust manifold and gasket.

INTAKE AND EXHAUST SYSTEM

EMB -91

INSTALLATION E14FE64D

INTAKE MANIFOLD

1. Install the intake manifold and gasket.

Tightening torque

19 ~ 21N.m (190 ~ 210kgf.cm, 14 ~ 15lbf.ft)

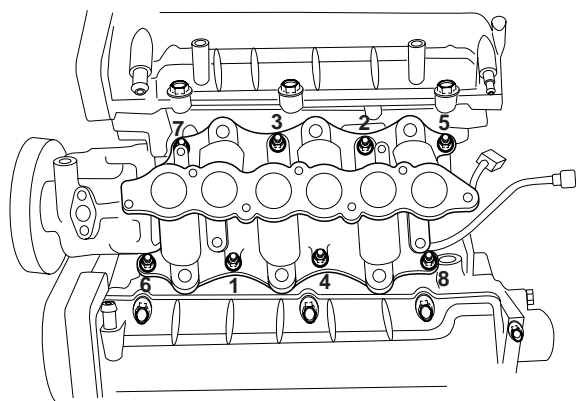

LUIF230A

2. Install the injector assembly. (See FL group - injector)
3. Install the surge tank assembly(A).
 - 1) Install the surge tank assembly.

Tightening torque

15 ~ 20N.m (150 ~ 200kgf.cm, 11 ~ 15lbf.ft)

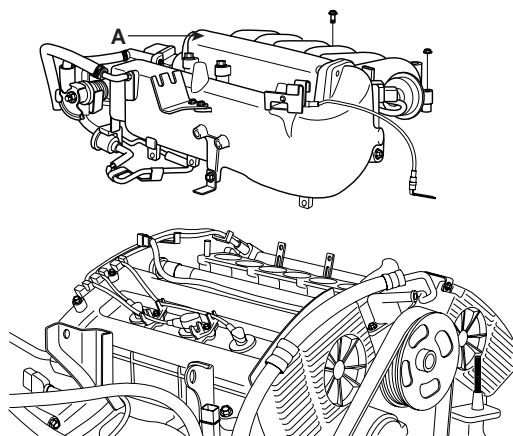

LUIF223A

- 2) Install the surge tank stay.

Tightening torque

15 ~ 20N.m (150 ~ 200kgf.cm, 11 ~ 15lbf.ft)

- 3) Install the ground cable.
- 4) Connect the VIS actuator connector.
- 5) Connect the IAT sensor connector.
- 6) Connect the PCV hose.
- 7) Connect the brake booster vacuum hose.
- 8) Connect the PCSV hose.
- 9) Connect the PCSV connector.
- 10) Connect the injector connector.
- 11) Connector the VIS actuator connector.
- 12) Connector the ISA connector.
- 13) Connector the TPS connector.
- 14) Connector the actuator cable.
4. Install the air cleaner hose.
5. Install the engine cover.

EMB -92

ENGINE (G6BA - GASOLINE 2.7)

EXHAUST MANIFOLD

1. Install the RH exhaust manifold and gasket.

Tightening torque

30 ~ 35 N.m (300 ~ 350kgf.cm, 22 ~ 26lb.ft)

2. Install the RH heat protector.

Tightening torque

17 ~ 22 N.m (170 ~ 220kgf.cm, 12 ~ 16lb.ft)

3. Install the RH drive shaft. (Refer to DS Gr.)
4. Install the alternator. (Refer to EE Gr.)
5. Install the exhaust manifold(A) and gasket(B).

Tightening torque

30 ~ 35N.m (300 ~ 350kgf.cm, 22 ~ 26lb.ft)

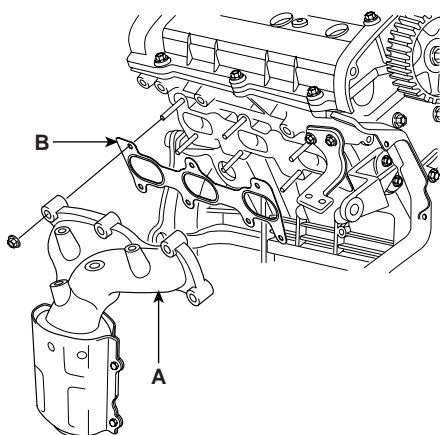

LUIF229A

6. Install the LH heat protector(A).

Tightening torque

12 ~ 15N.m (120 ~ 150kgf.cm, 9 ~ 11lb.ft)

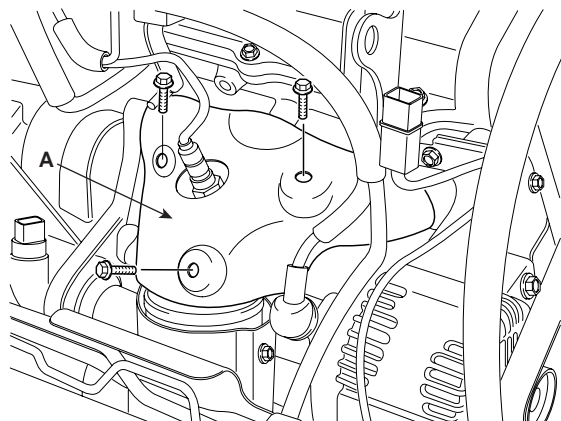

LUIF228A

7. Install the Air conditioner compressor. (Refer to HA Gr.)
8. Install the cooling fan motor assembly. (Refer to EMB - 73)
9. Connect the oxygen sensor connector.
10. Install the front exhaust pipe(A).

Tightening torque

30 ~ 40N.m (300 ~ 400kgf.cm, 22 ~ 30lb.ft)

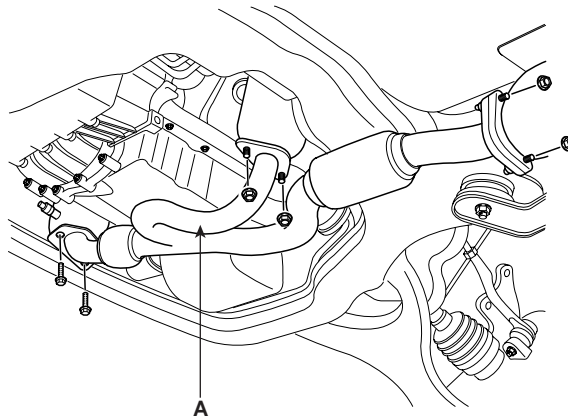

LUIF129A

11. Install the under cover(A).

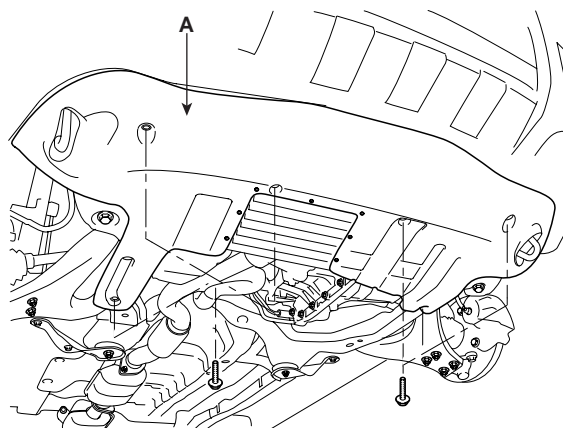

LUIF128A