

## EM-2

## Engine Mechanical System

### General Information

#### Specifications

Description		Specifications	Limit
<b>General</b>			
Type		V-type, DOHC	
Number of cylinders		6	
Bore		96mm(3.7795in.)	
Stroke		87.0mm(3.4252in.)	
Total displacement		3,778cc(230.55cu.in.)	
Compression ratio		10.4	
Firing order		1-2-3-4-5-6	
<b>Valve timing</b>			
Intake	Opens(ATDC)	10°(3.8L)	
	Closes(ABDC)	66°	
Exhaust	Opens(BBDC)	52°	
	Closes(ATDC)	0°	
<b>Cylinder head</b>			
Flatness of gasket surface		Less than 0.05mm (0.0019in.) [Less than 0.02mm (0.0008in.) / 150x150]	
Flatness of manifold mounting	Intake	Less than 0.1mm(0.0039in.) [Less than 0.03mm(0.001in.) / 110x110]	
	Exhaust	Less than 0.1mm(0.0039in.) [Less than 0.03mm(0.001in.) / 110x110]	
<b>Camshaft</b>			
Cam height	LH Camshaft	Intake	46.3mm(1.8228in.) / 46.8mm(1.8425in.)
		Exhaust	45.8mm (1.8031in.)
	RH Camshaft	Intake	46.3mm(1.8228in.) / 46.8mm(1.8425in.)
		Exhaust	45.8mm (1.8031in.)
Journal outer diameter	LH, RHcamshaft	Intake	No.1: 27.964 ~ 27.978mm (1.1009 ~ 1.1015in.) No.2,3,4: 23.954 ~ 23.970mm(0.9430 ~ 0.9437in.)
		Exhaust	No.1: 27.964 ~ 27.978mm(1.1009 ~ 1.1015in.) No.2,3,4: 23.954 ~ 23.970mm(0.9430 ~ 0.9437in.)
Bearing oil clearance	LH, RHcamshaft	Intake	No.1: 0.027 ~ 0.057mm (0.0011 ~ 0.0022in.) No.2,3,4: 0.030 ~ 0.067mm (0.0012 ~ 0.0026in.)
		Exhaust	No.1: 0.027 ~ 0.057mm (0.0011 ~ 0.0022in.) No.2,3,4: 0.030 ~ 0.067mm (0.0012 ~ 0.0026in.)
End play		0.02 ~ 0.18mm (0.0008 ~ 0.0071in.)	
<b>Valve</b>			

## General Information

EM-3

Description		Specifications	Limit
Valve length	Intake	105.27mm(4.1445in.)	
	Exhaust	105.50mm (4.1535in.)	
Stem outer diameter	Intake	5.465 ~ 5.480mm (0.2151 ~ 0.2157in.)	
	Exhaust	5.458 ~ 5.470mm (0.2149 ~ 0.2153in.)	
Face angle		45.25° ~ 45.75°	
Thickness of valvehead(margin)	Intake	1.56 ~ 1.86mm (0.06142 ~ 0.07323in.)	
	Exhaust	1.73 ~ 2.03mm (0.06811 ~ 0.07992in.)	
Valve stem to valve guide clearance	Intake	0.020 ~ 0.047mm (0.00078 ~ 0.00185in.)	0.07mm (0.00275in.)
	Exhaust	0.030 ~ 0.054mm (0.00118 ~ 0.00212in.)	0.09mm (0.00354in.)
<b>Valve guide</b>			
Inner diameter	Intake	5.500 ~ 5.512mm (0.2165 ~ 0.2170in.)	
	Exhaust	5.500 ~ 5.512mm (0.2165 ~ 0.2170in.)	
Length	Intake	41.8 ~ 42.2mm (1.6457 ~ 1.6614in.)	
	Exhaust	41.8 ~ 42.2mm (1.6457 ~ 1.6614in.)	
<b>Valve seat</b>			
Width of seat contact	Intake	1.15 ~ 1.45mm(0.05118 ~ 0.05709in.)	
	Exhaust	1.35 ~ 1.65mm(0.05315 ~ 0.06496in.)	
Seat angle	Intake	44.75° ~ 45.20°	
	Exhaust	44.75° ~ 45.20°	
<b>Valve spring</b>			
Free length		43.86mm (1.7267in.)	
Load	19.3±0.8kg/34.0mm (42.7±1.8 lb/1.3386in.)		
	41.5±1.3kg/24.2mm (91.5±2.9 lb/0.9527in.)		
Out of squareness		Less than 1.5°	
<b>MLA</b>			
MLA outer diameter	Intake	34.964 ~ 34.980mm (1.3765 ~ 1.3772in.)	
	Exhaust	34.964 ~ 34.980mm (1.3765 ~ 1.3772in.)	
Cylinder head tappet bore inner diameter	Intake	35.000 ~ 35.025mm (1.3779 ~ 1.3789in.)	
	Exhaust	35.000 ~ 35.025mm (1.3779 ~ 1.3789in.)	
MLA to tappet bore clearance	Intake	0.020 ~ 0.061mm (0.0008 ~ 0.0024in.)	0.07mm (0.0027in.)
	Exhaust	0.020 ~ 0.061mm (0.0008 ~ 0.0024in.)	0.07mm (0.0027in.)
<b>Valve clearance (At 20°C [68°F])</b>			
Intake		0.17 ~ 0.23mm (0.0067 ~ 0.0090in.)	0.10 ~ 0.30mm (0.0039 ~ 0.0118in.)

## EM-4

## Engine Mechanical System

Description		Specifications	Limit
Exhaust		0.27 ~ 0.33mm (0.0106 ~ 0.0129in.)	0.20 ~ 0.40mm (0.0078 ~ 0.0157in.)
<b>Cylinder block</b>			
Cylinder bore		92.00 ~ 92.03mm (3.6220 ~ 3.6232in.) / 96.00 ~ 96.03mm (3.7795 ~ 3.7807in.)	
Flatness of gasket surface		Less than 0.05mm (0.0019in.) [Less than 0.02mm (0.0008in.) / 150x150]	
<b>Piston</b>			
Piston outer diameter		91.96 ~ 91.99mm(3.6204 ~ 3.6216in.) / 95.96 ~ 95.99mm(3.7779 ~ 3.7791in.)	
Piston to cylinder clearance		0.03 ~ 0.05mm(0.0012 ~ 0.0020in.)	
Ring groove width	No. 1 ring groove	1.22 ~ 1.24mm (0.0480 ~ 0.0488in.)	1.26mm (0.0496in.)
	No. 2 ring groove	1.22 ~ 1.24mm (0.0480 ~ 0.0488in.)	1.26mm (0.0496in.)
	Oil ring groove	2.01 ~ 2.03mm (0.0791 ~ 0.0799in.)	2.05mm (0.0807in.)
<b>Piston ring</b>			
Side clearance	No. 1 ring	0.03 ~ 0.07mm (0.0012 ~ 0.0027in.)	0.1mm (0.004in.)
	No. 2 ring	0.03 ~ 0.07mm (0.0012 ~ 0.0027in.)	0.1mm (0.004in.)
	Oil ring	0.06 ~ 0.15mm (0.0024 ~ 0.0059in.)	0.2mm (0.008in.)
End gap	No. 1 ring	0.17 ~ 0.32mm (0.0067 ~ 0.0126in.)	0.6mm (0.0236in.)
	No. 2 ring	0.32 ~ 0.47mm (0.0126 ~ 0.0185in.)	0.7mm (0.0275in.)
	Oil ring	0.20 ~ 0.70mm (0.0078 ~ 0.0275in.)	0.8mm (0.0315in.)
<b>Piston pin</b>			
Piston pin outer diameter		23.001 ~ 23.006mm (0.9055 ~ 0.9057in.)	
Piston pin hole inner diameter		23.016 ~ 23.021mm (0.9061 ~ 0.9063in.)	
Piston pin hole clearance		0.01 ~ 0.02mm (0.0004 ~ 0.0008in.)	
Connecting rod small end inner diameter		22.974 ~ 22.985mm (0.9045 ~ 0.9049in.)	
Connecting rod small end hole clearance		-0.032 ~ -0.016mm (-0.0012 ~ 0.0006in.)	
<b>Connecting rod</b>			
Connecting rod big end inner diameter		58.000 ~ 58.018mm(2.2834 ~2.2842in.)	
Connecting rod bearing oil clearance		0.038 ~ 0.056mm (0.0015 ~ 0.0022in.)	
Side clearance		0.1 ~ 0.25mm (0.0039 ~ 0.0098in.)	
<b>Crankshaft</b>			
Main journal outer diameter		68.942 ~ 68.960mm (2.7142 ~ 2.7149in.)	
Pin journal outer diameter		54.954 ~ 54.972mm (2.1635 ~ 2.1642in.)	
Main bearing oil clearance		0.022 ~ 0.040mm (0.0008 ~ 0.0016in.)	
End play		0.10 ~ 0.28mm (0.0039 ~ 0.0110in.)	

## General Information

EM-5

Description		Specifications	Limit
<b>Oil pump</b>			
Relief valve opening pressure		450 ~ 550kPa (4.59 ~ 5.61kgf/cm <sup>2</sup> , 65.28 ~ 79.79psi)	
<b>Engine oil</b>			
Oil quantity (Total)		6.0L(6.34U.S.qts, 5.28Imp.qts)	When replacing a short engine or a block assembly
Oil quantity (Oil pan)		5.5L(5.81U.S.qts, 4.84Imp.qts)	When replacing an oil pan only.
Oil quantity (Drain and refill include oil filter)		5.2L(5.49U.S.qts, 4.58Imp.qts)	
Oil quality		Above SJ or SL, SAE 5w-20	
Oil pressure		130kPa(1.32kgf/cm <sup>2</sup> , 18.77psi) [at 1000rpm, 110°C(230°F)]	
<b>Cooling system</b>			
Cooling method		Forced circulation with water pump	
Coolant quantity		11.4 L (12.0 us.qts, 10.0 Imp.qts)	
Thermostat	Type	Wax pellet type	
	Opening temperature	82±2°C (179.6±35.6°F)	
	Fully opened temperature	95°C (203°F)	
	Full lift	10mm (0.3937in.) MIN	
Radiator cap	Main valve opening pressure	93.16 ~ 122.58kpa (0.95 ~ 1.25kg/cm <sup>2</sup> , 13.51 ~ 17.78psi)	
	Vacuum valve opening pressure	0 ~ 6.86 kpa (0 ~ 0.07kg/cm <sup>2</sup> , 0 ~ 0.99psi)	
<b>Water temperature sensor</b>			
Type		Thermister type	
Resistance	20°C (68°F)	2.31 ~ 2.59KΩ	
	80°C(176°F)	0.3222 KΩ	

## EM-6

## Engine Mechanical System

### Tightening Torques

Item	Quantity	Nm	kgf.m	lb-ft
Crankshaft pulley bolt	1	284.4 ~ 304.0	29.0 ~ 31.0	209.8 ~ 224.2
Timing chain cover bolt B	17	18.6 ~ 21.6	1.9 ~ 2.2	13.7 ~ 15.9
Timing chain cover bolt C	4	9.8 ~ 11.8	1.0 ~ 1.2	7.2 ~ 8.7
Timing chain cover bolt D	2	58.8 ~ 68.6	6.0 ~ 7.0	43.4 ~ 50.6
Timing chain cover bolt F	2	24.5 ~ 26.5	2.5 ~ 2.7	18.1 ~ 19.5
Timing chain cover bolt G	4	21.6 ~ 23.5	2.2 ~ 2.4	15.9 ~ 17.4
Timing chain cover bolt H	1	9.8 ~ 11.8	1.0 ~ 1.2	7.2 ~ 8.7
Timing chain cover bolt I	1	9.8 ~ 11.8	1.0 ~ 1.2	7.2 ~ 8.7
Timing chain cover bolt J	1	9.8 ~ 11.8	1.0 ~ 1.2	7.2 ~ 8.7
Timing chain cover bolt K	4	9.8 ~ 11.8	1.0 ~ 1.2	7.2 ~ 8.7
Timing chain cover bolt L	1	21.6 ~ 26.5	2.2 ~ 2.7	15.9 ~ 19.5
Timing chain auto tensioner bolt	2	9.8 ~ 11.8	1.0 ~ 1.2	7.2 ~ 8.7
Timing chain auto tensioner nut	2	9.8 ~ 11.8	1.0 ~ 1.2	7.2 ~ 8.7
Timing chain auto tensioner arm bolt	2	18.6 ~ 21.6	1.9 ~ 2.2	13.7 ~ 15.9
Timing chain guide bolt	4	19.6 ~ 24.5	2.0 ~ 2.5	14.5 ~ 18.1
Oil pump chain cover bolt	2	9.8 ~ 11.8	1.0 ~ 1.2	7.2 ~ 8.7
Oil pump chain tensioner bolt	1	9.8 ~ 11.8	1.0 ~ 1.2	7.2 ~ 8.7
Oil pump chain guide bolt	2	9.8 ~ 11.8	1.0 ~ 1.2	7.2 ~ 8.7
Oil pump chain sprocket bolt	1	18.6 ~ 21.6	1.9 ~ 2.2	13.7 ~ 15.9
Lower oil pan bolt	13	9.8 ~ 11.8	1.0 ~ 1.2	7.2 ~ 8.7
Drive belt auto tensioner bolt(M12)	1	81.4 ~ 85.3	8.3 ~ 8.7	60.0 ~ 62.9
Drive belt auto tensioner bolt(M8)	1	17.7 ~ 21.6	1.8 ~ 2.2	13.0 ~ 15.9
Drive belt idler bolt	1	53.9 ~ 57.9	5.5 ~ 5.9	39.8 ~ 42.7
OCV(oil control valve) bolt	2	9.8 ~ 11.8	1.0 ~ 1.2	7.2 ~ 8.7
Cylinder head bolt	16	39.2 + 120° + 90°	4.0 + 120° + 90°	28.9 + 120° + 90°
Cylinder head bolt	1	18.6 ~ 23.5	1.9 ~ 2.4	13.7 ~ 17.4
CVVT & cam sprocket bolt	4	64.7 ~ 76.5	6.6 ~ 7.8	47.7 ~ 56.4
Camshaft bearing cap bolt	32	9.8 ~ 11.8	1.0 ~ 1.2	7.2 ~ 8.7
Cylinder head cover bolt	38	9.8 ~ 11.8	1.0 ~ 1.2	7.2 ~ 8.7
Connecting rod bearing bolt	12	19.6 + 90°	2.0 + 90°	14.5 + 90°
Main bearing cap inner bolt(M11)	8	49.0 + 90°	5.0 + 90°	36.2 + 90°
Main bearing cap outer bolt(M8)	8	19.6 + 120°	2.0 + 120°	14.5 + 120°
Main bearing cap side bolt(M8)	8	29.4 ~ 31.4	3.0 ~ 3.2	21.7 ~ 23.1
Oil drain cover bolt	6	9.8 ~ 11.8	1.0 ~ 1.2	7.2 ~ 8.7

## General Information

EM-7

Item	Quantity	Nm	kgf.m	lb-ft
Rear oil seal case bolt	6	9.8 ~ 11.8	1.0 ~ 1.2	7.2 ~ 8.7
Baffle plate bolt	12	9.8 ~ 11.8	1.0 ~ 1.2	7.2 ~ 8.7
Upper oil pan bolt	16	9.8 ~ 11.8	1.0 ~ 1.2	7.2 ~ 8.7
Knock sensor bolt	2	15.7 ~ 23.5	1.6 ~ 2.4	11.6 ~ 17.4
Drive plate bolt cap	8	71.54 ~ 75.46	7.3 ~ 7.7	52.80 ~ 55.69
Oil filter cap		24.5	2.5	18.1
Oil drain bolt cap	1	34.3 ~ 44.1	3.5 ~ 4.5	25.3 ~ 32.5
Oil pump bolt	3	20.6 ~ 22.6	2.1 ~ 2.3	15.2 ~ 16.6
Oil filter body bolt	10	9.8 ~ 11.8	1.0 ~ 1.2	7.2 ~ 8.7
Water pump bolt(Timing chain cover bolt L)	1	21.6 ~ 26.5	2.2 ~ 2.7	15.9 ~ 19.5
Water pump bolt(Timing chain cover bolt K)	4	9.8 ~ 11.8	1.0 ~ 1.2	7.2 ~ 8.7
Water pump bolt(Timing chain cover bolt G)	4	21.6 ~ 23.5	2.2 ~ 2.4	15.9 ~ 17.4
Water pump pulley bolt	4	7.8 ~ 9.8	0.8 ~ 1.0	5.8 ~ 7.2
Water temp. control nut	4	19.6 ~ 23.5	2.0 ~ 2.4	14.5 ~ 17.4
Water temp. control bolt	2	19.6 ~ 23.5	2.0 ~ 2.4	14.5 ~ 17.4
Water inlet pipe bolt	3	16.7 ~ 19.6	1.7 ~ 2.0	12.3 ~ 14.5
Air vent pipe bolt	2	9.8 ~ 11.8	1.0 ~ 1.2	7.2 ~ 8.7
Intake manifold bolt	6	26.5 ~ 31.4	2.7 ~ 3.2	19.5 ~ 23.1
Intake manifold nut	2	18.6 ~ 23.5	1.9 ~ 2.4	13.7 ~ 17.4
Surge tank bolt (M6 × 36)	4	9.8 ~ 11.8	1.0 ~ 1.2	7.2 ~ 8.7
Surge tank bolt (M6 × 128)	2	9.8 ~ 11.8	1.0 ~ 1.2	7.2 ~ 8.7
Surge tank nut	2	9.8 ~ 11.8	1.0 ~ 1.2	7.2 ~ 8.7
Breather pipe bolt	2	9.8 ~ 11.8	1.0 ~ 1.2	7.2 ~ 8.7
Surge tank stay bolt (M10 × 20 )	2	27.5 ~ 31.4	2.8 ~ 3.2	20.3 ~ 23.1
ETC bracket bolt	2	15.7 ~ 25.5	1.6 ~ 2.6	11.6 ~ 18.8
Exhaust manifold nut	16	39.2 ~ 44.1	4.0 ~ 4.5	28.9 ~ 32.6
Heat protector bolt	6	9.8 ~ 11.8	1.0 ~ 1.2	7.2 ~ 8.7
Front muffler nut	8	39.2 ~ 58.8	4.0 ~ 6.0	28.9 ~ 43.4
Center muffler nut	4	39.2 ~ 58.8	4.0 ~ 6.0	28.9 ~ 43.4
Main muffler nut	4	39.2 ~ 58.8	4.0 ~ 6.0	28.9 ~ 43.4
Air cleaner assembly bolt	2	7.8 ~ 9.8	0.8 ~ 1.0	5.8 ~ 7.2
Intake air hose clamp bolt	1	1.9 ~ 2.9	0.2 ~ 0.3	1.4 ~ 2.2

## EM-8

# Engine Mechanical System

### Inspection

#### Compression Pressure

##### NOTICE

If there is lack of power, excessive oil consumption or poor fuel economy, measure the compression pressure.

1. Warm up engine to the normal operating temperature(80~95°C(176~203°F)).
2. Remove the surge tank. (Refer to Intake and exhaust system in this group)
3. Remove the ignition coil connectors (A) and ignition coils (B).

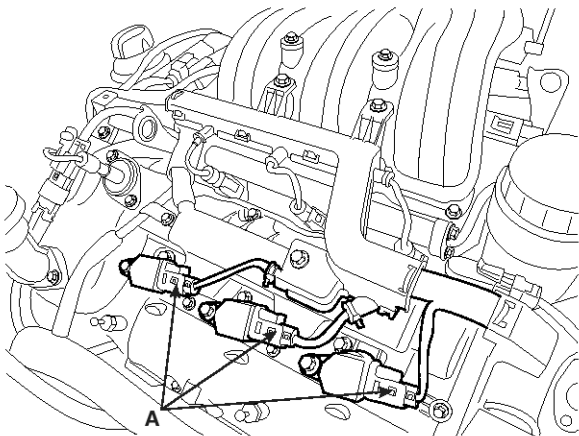

SBHEM8099D

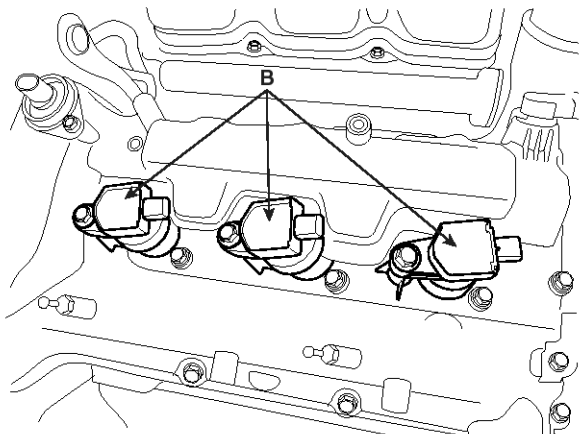

SBHEM8150D

4. Remove the spark plugs.  
Using a 16mm plug wrench, remove the 6 spark plugs.
5. Check cylinder compression pressure.
  - 1) Insert a compression gauge into the spark plug hole.
  - 2) Fully open the throttle.
  - 3) Crank the engine over 7 times to measure compression pressure.

##### NOTICE

Always use a fully charged battery to obtain engine speed of 250 rpm or more.

- 4) Repeat step 1) through 3) for each cylinder.

##### NOTICE

This measurement must be done in as short a time as possible.

#### Compression pressure :

1,029kPa (10.5kgf/cm<sup>2</sup>, 149psi) (250~400 rpm)

#### Minimum pressure :

882kPa (9.0kgf/cm<sup>2</sup>, 128psi)

- 5) If the cylinder compression in 1 or more cylinders is low, pour a small amount of engine oil into the cylinder through the spark plug hole and repeat step 1) through 3) for cylinders with low compression.
  - a. If adding oil helps the compression, it is likely that the piston rings and/or cylinder bore are worn or damaged.
  - b. If pressure stays low, a valve may be sticking or seating is improper, or there may be leakage past the gasket.
6. Reinstall the spark plugs.
7. Install the ignition coils and ignition connectors.
8. Install the surge tank. (Refer to Intake and exhaust system in this group)

## Valve Clearance Inspection And Adjustment

### NOTICE

Inspect and adjust the valve clearance when the engine is cold (Engine coolant temperature : 20°C(68°F)) and cylinder head is installed on the cylinder block.

1. Remove the engine cover.
2. Remove the engine side cover.
3. Remove air cleaner assembly.
4. Remove the surge tank. (Refer to Intake and exhaust system in this group)
5. Remove the cylinder head cover. (Refer to Timing system in this group)
6. Set No.1 cylinder to TDC/compression.
  - 1) Turn the crankshaft pulley clockwise and align its groove with the timing mark "T" of the lower timing chain cover.

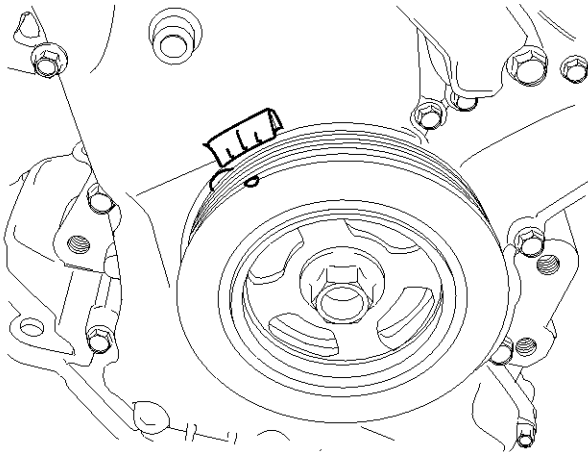

KDRF108A

- 2) Check that the mark (A) of the camshaft timing sprockets are lined up on the cylinder head surface as shown in the illustration.

If not, turn the crankshaft clockwise one revolution (360°).

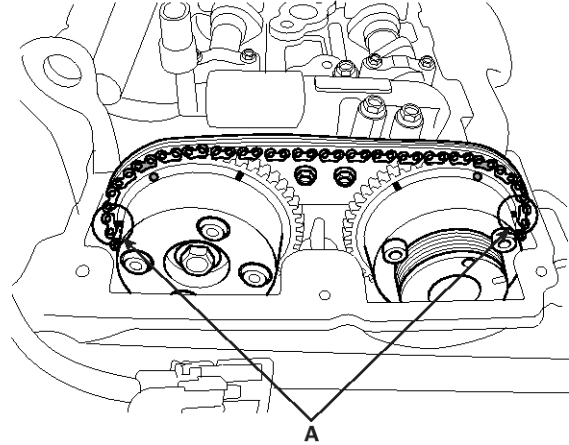

SBHEM8060D

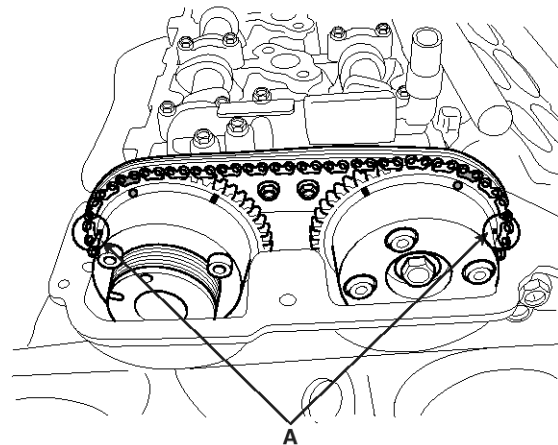

SBHEM8061D

### NOTICE

Do not rotate engine counterclockwise.

## EM-10

## Engine Mechanical System

7. Inspect the valve clearance.

- 1) With No.1 cylinder at TDC inspect clearances only on the valves shown in diagram below.

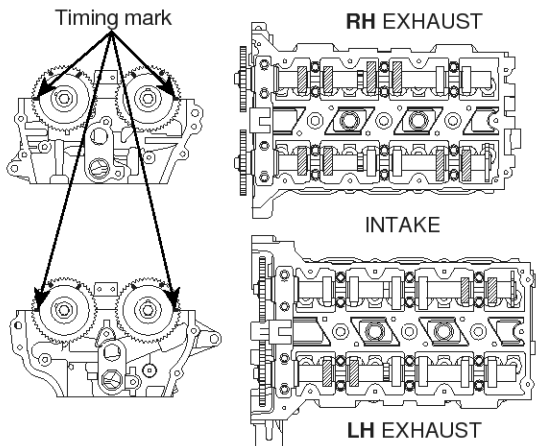

EDRF021A

Measurement method.

- a. Using a thickness gauge, measure the clearance between the tappet and the base circle of camshaft.
- b. Record the out-of-specification valve clearance measurements. They will be used later to determine the required replacement adjusting tappet.

### Valve clearance

Specification

Engine coolant temperature : 20°C [68°F]

Limit

Intake : 0.10 ~ 0.30mm (0.0039 ~ 0.0118in.)

Exhaust : 0.20 ~ 0.40mm (0.0078 ~ 0.0157in.)

- 2) Turn the crankshaft pulley clockwise one revolution (360°) and align the groove with timing mark "T" of the lower timing chain cover.
- 3) With No.4 cylinder at TDC inspect clearances only the valves shown in diagram below. (Refer to procedure step 1.)

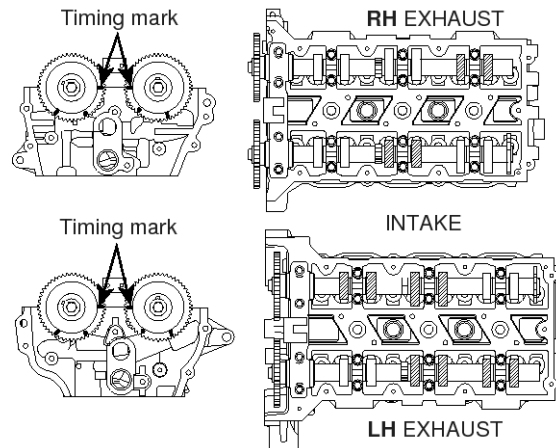

EDRF022A

## General Information

8. Adjust the intake and exhaust valve clearance.
  - 1) Set the No.1 cylinder to the TDC/compression.
  - 2) Remove the timing chain.

### NOTICE

Before removing the timing chain, mark the RH/LH timing chain with an identification based on the location of the sprocket because the identification mark on the chain for TDC (Top Dead Center) can be erased.

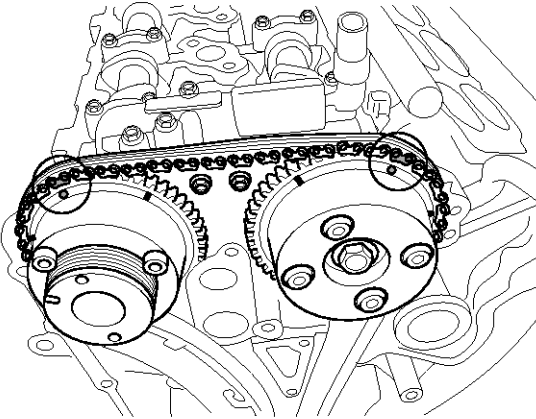

SBHEM8063D

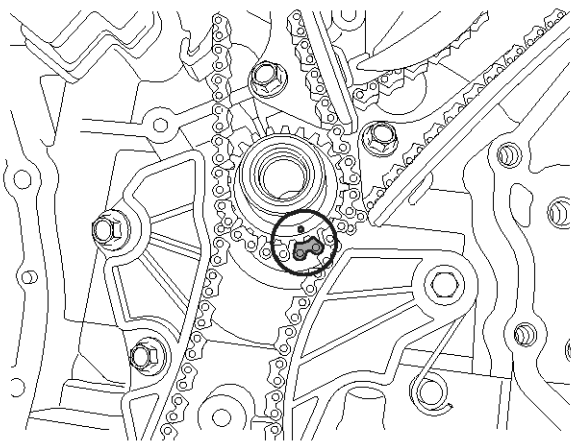

KDRF129A

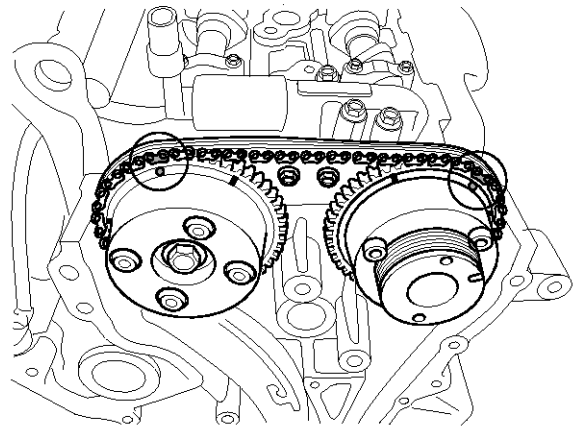

SBHEM8062D

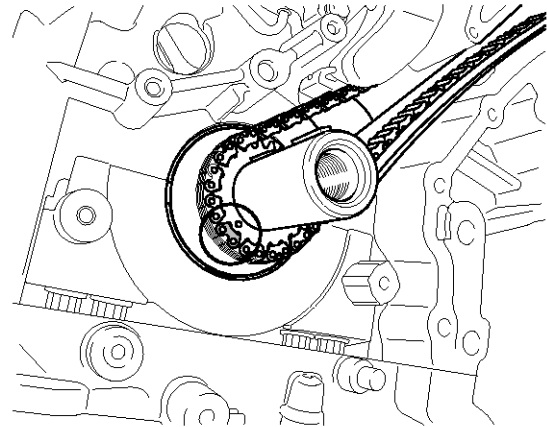

SBHEM8074D

## EM-12

## Engine Mechanical System

- 3) Remove the LH/RH camshaft bearing cap (A) and thrust bearing cap (B).

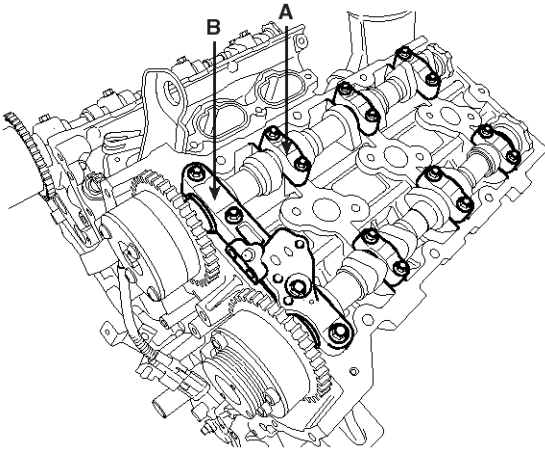

SBHEM8070D

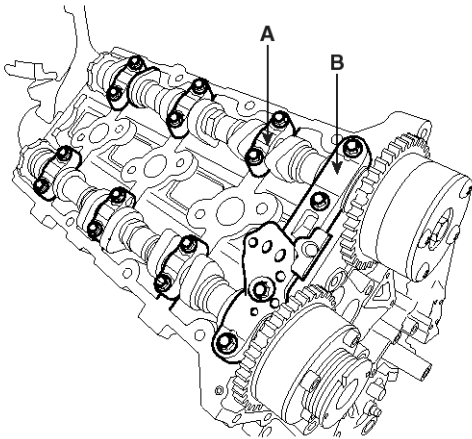

SBHEM8071D

- 4) Remove the LH/RH camshaft assembly (A).

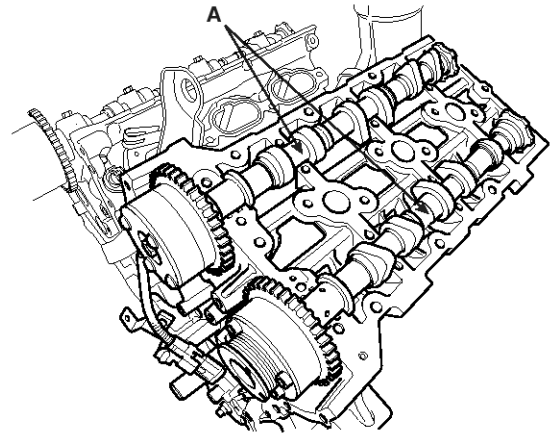

SBHEM8072D

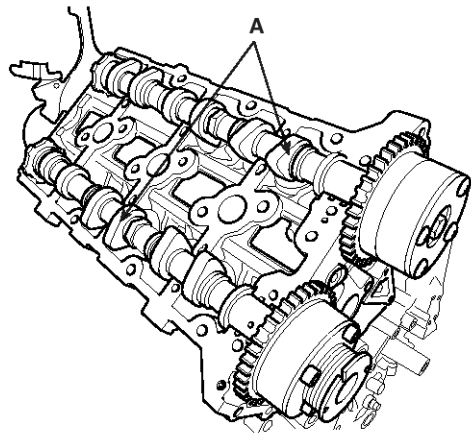

SBHEM8073D

## General Information

## EM-13

- 5) Remove the MLA.
- 6) Measure the thickness of the removed tappet using a micrometer.

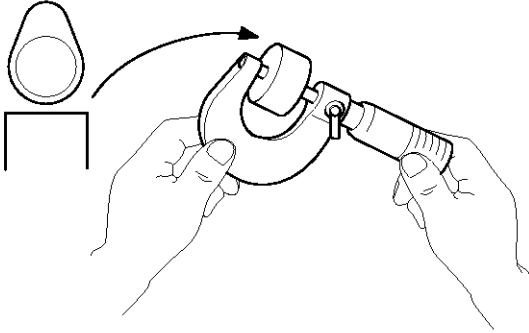

EDKE889D

- 7) Calculate the thickness of a new tappet so that the valve clearance comes within the specified value.

**T** : Thickness of removed tappet

**A** : Measured valve clearance

**N** : Thickness of new tappet

**Intake** :  $N = T + [A - 0.20\text{mm}(0.0079\text{in.})]$

**Exhaust** :  $N = T + [A - 0.30\text{mm}(0.0118\text{in.})]$

- 8) Select a new tappet with a thickness as close as possible to the calculated value.

### NOTICE

Shims are available in 41 size increments of 0.015mm (0.0006in.) from 3.00mm (0.118in.) to 3.600mm (0.1417in.)

- 9) Place a new tappet on the cylinder head.

### NOTICE

Apply engine oil at the selected tappet on the periphery and top surface.

- 10) Install the intake and exhaust camshaft.
- 11) Install the bearing caps. (Refer to Cylinder head assembly in this Group)
- 12) Install the timing chain. (Refer to Timing system in this Group)

- 13) Turn the crankshaft two turns in the operating direction (clockwise) and realign crankshaft sprocket and camshaft sprocket timing marks (A).

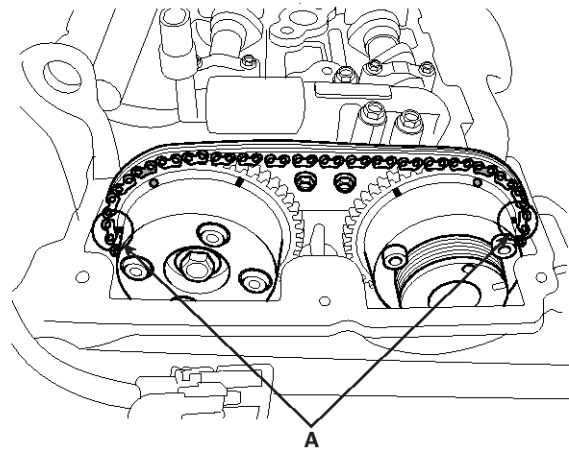

SBHEM8060D

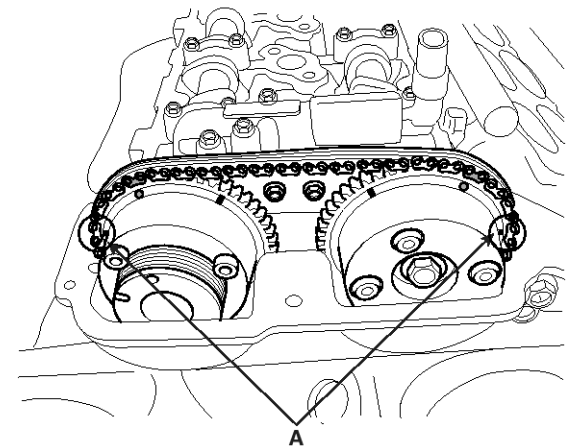

SBHEM8061D

- 14) Recheck the valve clearance.

**Valve clearance (Engine coolant temperature : 20°C [68°F])**

### **[Specification]**

Intake : 0.17 ~ 0.23mm (0.0067 ~ 0.0090in.)

Exhaust : 0.27 ~ 0.33mm (0.0106 ~ 0.0129in.)

## EM-14

# Engine Mechanical System

### Troubleshooting

Symptom	Suspect area	Remedy
Engine misfire with abnormal internal lower engine noises.	Worn crankshaft bearings. Loose or damaged engine drive plate.	Replace the crankshaft and bearings as required. Repair or replace the drive plate as required.
	Worn piston rings. (Oil consumption may or may not cause the engine to misfire.)	Inspect the cylinder for a loss of compression. Repair or replace as required.
	Worn crankshaft thrust bearings	Replace the crankshaft and bearings as required.
Engine misfire with abnormal valve train noise.	Stuck valves. (Carbon buildup on the valve stem)	Repair or replace as required.
	Excessive worn or mis-aligned timing chain.	Replace the timing chain and sprocket as required.
	Worn camshaft lobes.	Replace the camshaft and valve lifters.
Engine misfire with coolant consumption.	<ul style="list-style-type: none"><li>Faulty cylinder head gasket and/or cranking or other damage to the cylinder head and engine block cooling system</li><li>Coolant consumption may or may not cause the engine to overheat.</li></ul>	<ul style="list-style-type: none"><li>Inspect the cylinder head and engine block for damage to the coolant passages and/or a faulty head gasket.</li><li>Repair or replace as required.</li></ul>
Engine misfire with excessive oil consumption.	Worn valves, guides and/or valve stem oil seals.	Repair or replace as required.
	Worn piston rings. (Oil consumption may or may not cause the engine to misfire)	<ul style="list-style-type: none"><li>Inspect the cylinder for a loss of compression.</li><li>Repair or replace as required.</li></ul>
Engine noise on start-up, but only lasting a few seconds.	Incorrect oil viscosity.	<ul style="list-style-type: none"><li>Drain the oil. • Install the correct viscosity oil.</li></ul>
	Worn crankshaft thrust bearing.	<ul style="list-style-type: none"><li>Inspect the thrust bearing and crankshaft.</li><li>Repair or replace as required.</li></ul>

## General Information

## EM-15

Symptom	Suspect area	Remedy
Upper engine noise, regardless of engine speed.	Low oil pressure.	Repair or replace as required.
	Broken valve spring.	Replace the valve spring.
	Worn or dirty valve lifters.	Replace the valve lifters.
	Stretched or broken timing chain and/or damaged sprocket teeth.	Replace the timing chain and sprockets.
	Worn timing chain tensioner, if applicable.	Replace the timing chain tensioner as required.
	Worn camshaft lobes.	<ul style="list-style-type: none"><li>Inspect the camshaft lobes.</li><li>Replace the timing camshaft and valve lifters as required.</li></ul>
	Worn valve guides or valve stems.	Inspect the valves and valve guides, then repair as required.
	Stuck valves. Carbon on the valve stem or valve seat may cause the valve to stay open.	Inspect the valves and valve guides, then repair as required.
	Worn drive belt, idler, tensioner and bearing.	Replace as required.
Lower engine noise, regardless of engine speed.	Low oil pressure.	Repair as required.
	Loose or damaged drive plate.	Repair or replace the drive plate.
	Damaged oil pan, contacting the oil pump screen.	<ul style="list-style-type: none"><li>Inspect the oil pan.</li><li>Inspect the oil pump screen.</li><li>Repair or replace as required.</li></ul>
	Oil pump screen loose, damaged or restricted.	<ul style="list-style-type: none"><li>Inspect the oil pump screen.</li><li>Repair or replace as required.</li></ul>
	Excessive piston-to-cylinder bore clearance.	<ul style="list-style-type: none"><li>Inspect the piston, piston pin and cylinder bore.</li><li>Repair as required.</li></ul>
	Excessive piston pin-to-piston clearance.	<ul style="list-style-type: none"><li>Inspect the piston, piston pin and the connecting rod.</li><li>Repair or replace as required.</li></ul>
	Excessive connecting rod bearing clearance	Inspect the following components and repair as required. <ul style="list-style-type: none"><li>The connecting rod bearings.</li><li>The connecting rods.</li><li>The crankshaft pin journals.</li></ul>
	Excessive crankshaft bearing clearance.	Inspect the following components, and repair as required. <ul style="list-style-type: none"><li>The crankshaft bearings.</li><li>The crankshaft main journals.</li><li>The cylinder block.</li></ul>
	Incorrect piston, piston pin and connecting rod installation	<ul style="list-style-type: none"><li>Verify the piston pins and connecting rods are installed correctly.</li><li>Repair as required.</li></ul>

## EM-16



## Engine Mechanical System

Symptom	Suspect area	Remedy
Engine noise under load.	Low oil pressure	Repair or replace as required.
	Excessive connecting rod bearing clearance .	Inspect the following components and repair as required : <ul style="list-style-type: none"><li>• The connecting rod bearings.</li><li>• The connecting rods.</li><li>• The crankshaft.</li></ul>
	Excessive crankshaft bearing clearance.	Inspect the following components, and repair as required. <ul style="list-style-type: none"><li>• The crankshaft bearings.</li><li>• The crankshaft main journals.</li><li>• The cylinder block.</li></ul>
Engine will not crank-crankshaft will not rotate.	Hydraulically locked cylinder. <ul style="list-style-type: none"><li>• Coolant/antifreeze in cylinder.</li><li>• Oil in cylinder.</li><li>• Fuel in cylinder.</li></ul>	<ol style="list-style-type: none"><li>1. Remove spark plugs and check for fluid.</li><li>2. Inspect for broken head gasket.</li><li>3. Inspect for cracked engine block or cylinder head.</li><li>4. Inspect for a sticking fuel injector and/or leaking fuel regulator.</li></ol>
	Broken timing chain and/or timing chain and/or timing chain gears.	<ol style="list-style-type: none"><li>1. Inspect timing chain and gears.</li><li>2. Repair as required.</li></ol>
	Material in cylinder. <ul style="list-style-type: none"><li>• Broken valve</li><li>• Piston material</li><li>• Foreign material</li></ul>	<ol style="list-style-type: none"><li>1. Inspect cylinder for damaged components and/or foreign materials.</li><li>2. Repair or replace as required.</li></ol>
	Seized crankshaft or connecting rod bearings.	<ol style="list-style-type: none"><li>1. Inspect crankshaft and connecting rod bearing.</li><li>2. Repair as required.</li></ol>
	Bent or broken connecting rod.	<ol style="list-style-type: none"><li>1. Inspect connecting rods.</li><li>2. Repair as required.</li></ol>
	Broken crankshaft.	<ol style="list-style-type: none"><li>1. Inspect crankshaft.</li><li>2. Repair as required.</li></ol>

# General Information

EM-17

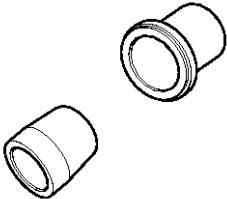
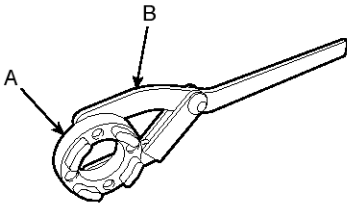
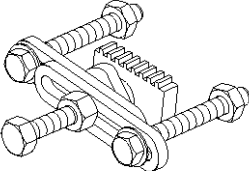
## Special Service Tools

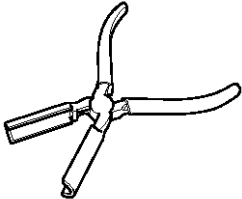
Tool (Number and name)	Illustration	Use
Crankshaft front oil seal installer (09231-3C100)	 KDRF233A	Installation of the front oil seal
Crankshaft pulley adapter (09231-2J200) Crankshaft pulley adapter holder (09231-2J210)	 SHMM19167N	Removal and installation of the crankshaft pulley. (In vehicle use) A : 09231-2J200 B : 09231-2J210 (holder)
Flywheel stopper (09231-3C300)	 SHDEM6201D	Removal and installation of the flywheel and crankshaft pulley (Engine disassembly)
Torque angle adapter (09221-4A000)	 LCAC030A	Installation of bolts & nuts needing an angular method
Valve stem seal remover (09222-29000)	 KDRF232A	Removal of the valve stem seal

# EM-18

# Engine Mechanical System

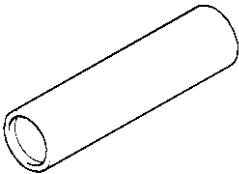
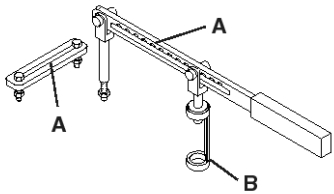
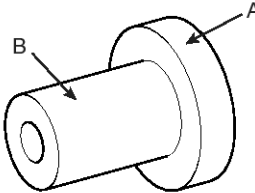
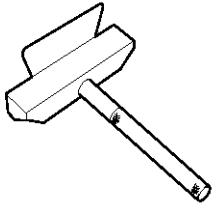
Tool (Number and name)	Illustration	Use
Valve stem seal installer (09222-3C100)	 <p data-bbox="788 517 884 539">LCAC030D</p>	Installation of the valve stem seal
Valve spring compressor & holder (09222-3K000) (09222-3C300)	 <p data-bbox="788 808 884 831">ECRF003A</p>	Removal and installation of the intake or exhaust valves A : 09222-3K000 B : 09222-3C300 (holder)
Crankshaft rear oil seal installer (09231-3C200) (09231-H1100)	 <p data-bbox="788 1099 884 1122">ACRF003A</p>	Installation of the crankshaft rear oil seal A : 09231-3C200 B : 09231-H1100
Oil pan remover (09215-3C000)	 <p data-bbox="788 1391 884 1413">KDRF219A</p>	Removal of oil pan

## Engine And Transmission Assembly

### Engine Mounting

#### Components

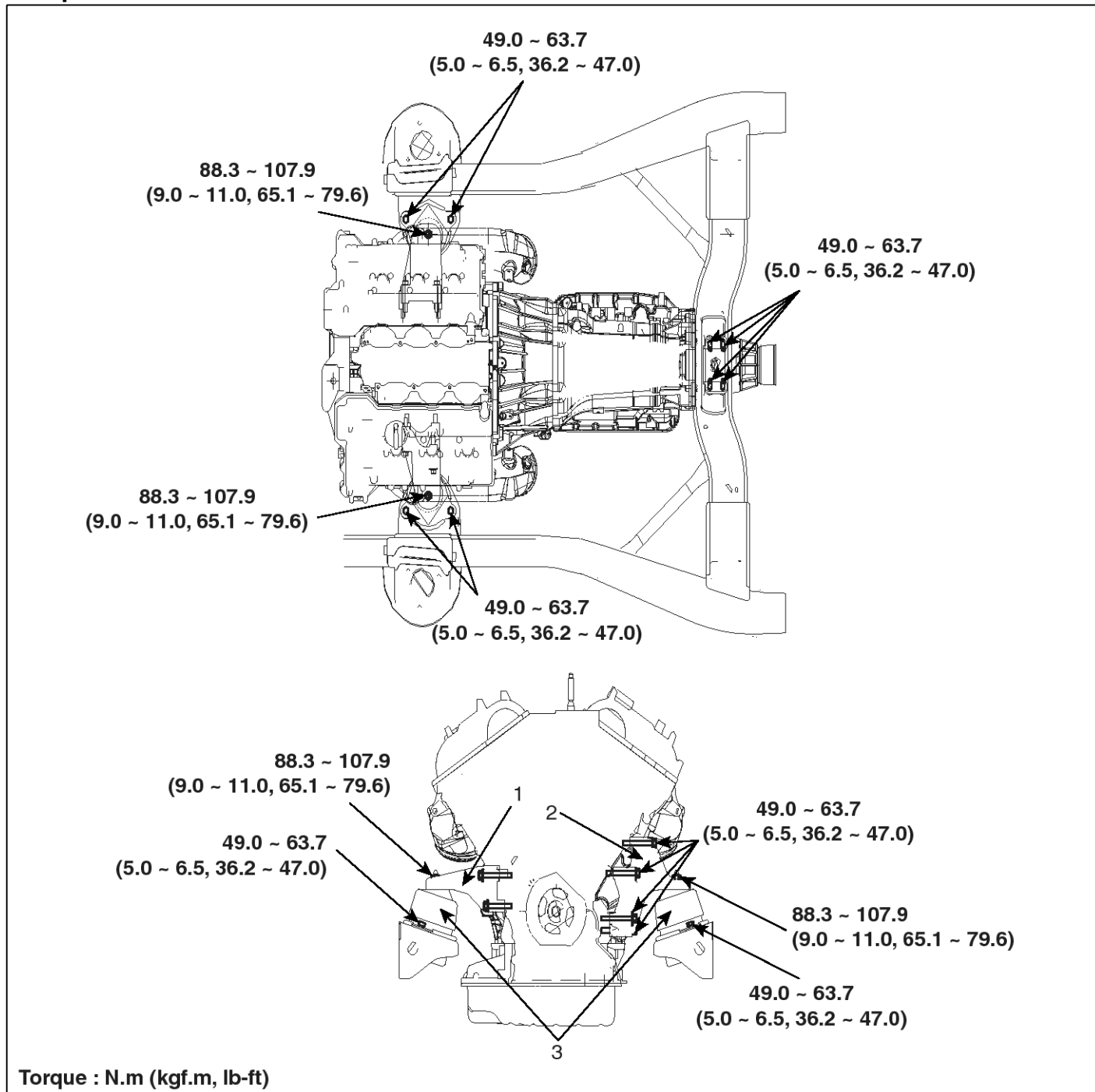

SHMEM9100L

- 1. Engine support bracket RH
- 2. Engine support bracket LH

- 3. Engine mounting insulator

## EM-20

## Engine Mechanical System

### Engine And Transmission Assembly

#### Removal

##### ⚠ CAUTION

- Use fender covers to avoid damaging painted surfaces.
- To avoid damage, unplug the wiring connectors carefully while holding the connector portion.

##### 📄 NOTICE

- Mark all wiring and hoses to avoid misconnection.
1. First, remove the transmission before removing the engine. (Refer to AT group)
  2. Remove the hood. (Refer to BD group)
  3. Remove the cowl cover and wiper arm. (Refer to BE group)
  4. Disconnect the negative cable(A) from the battery.

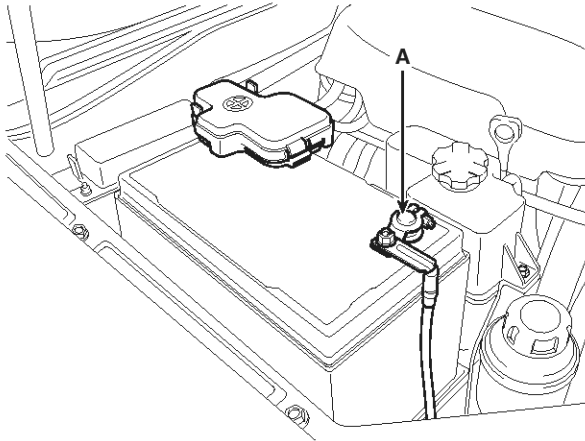

SHMM19043N

5. Remove the engine cover (A).

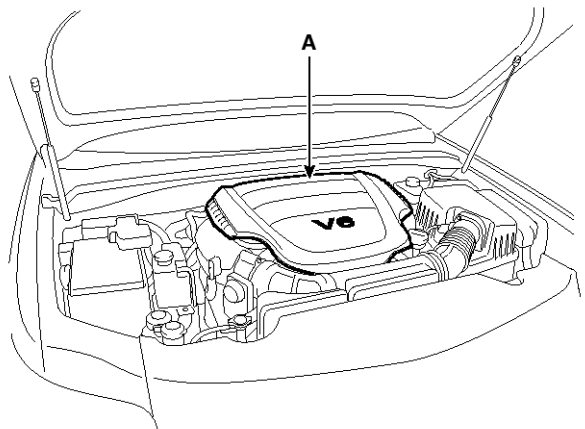

SHMEM9001L

6. Remove the radiator grill upper guard (A).

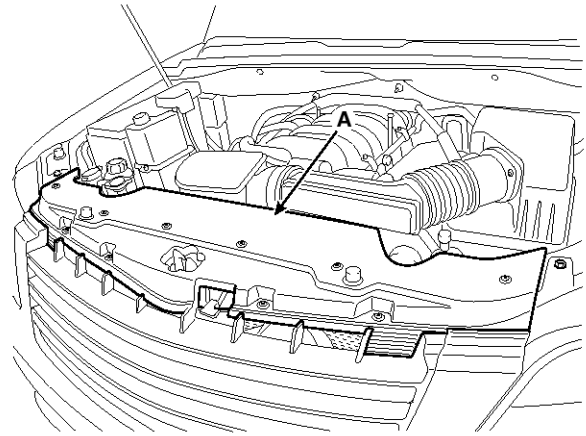

SHMM19045N

7. Loosen the drain plug and drain the engine coolant.  
Remove the radiator cap (A) to speed draining.

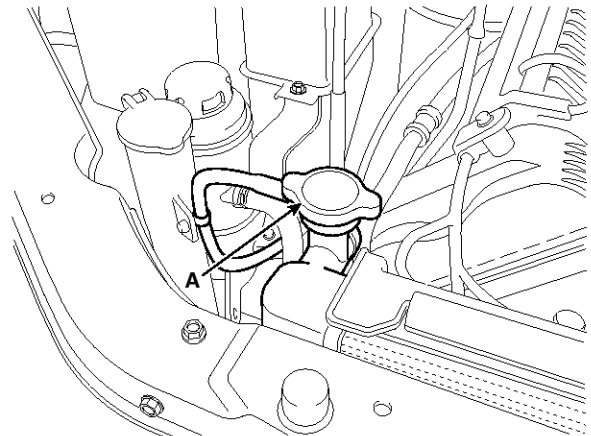

SHMM19047N

# Engine And Transmission Assembly

# EM-21

8. Recover refrigerant. (Refer to Air conditioner compressor in HA Group)

9. Disconnect the AFS connector (A) and breather hose (B) and then remove the air cleaner assembly (C).

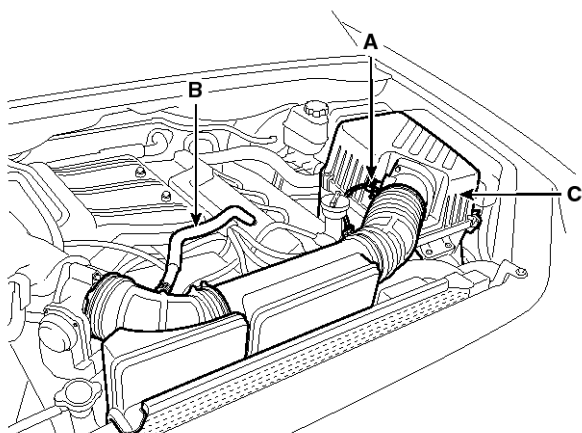

SHMEM9002L

10. Disconnect the radiator upper hose (A) and lower hose (B).

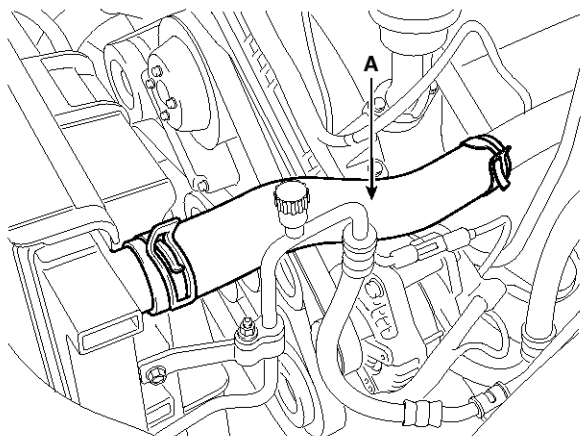

SHMEM9003L

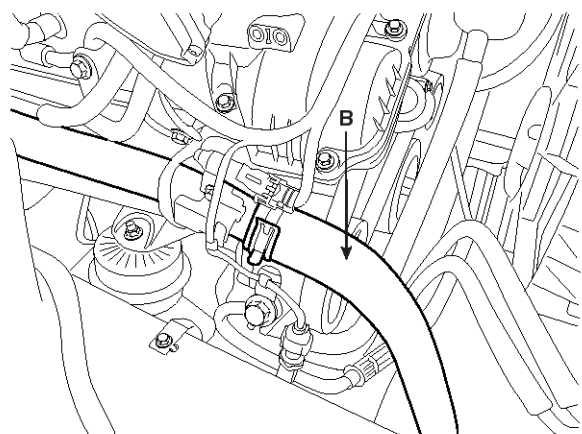

SBHEM8003D

11. Disconnect the heater hoses (A), the fuel hose (B), the purge control solenoid valve (PCSV) hose (C) and the brake booster vacuum hose (D).

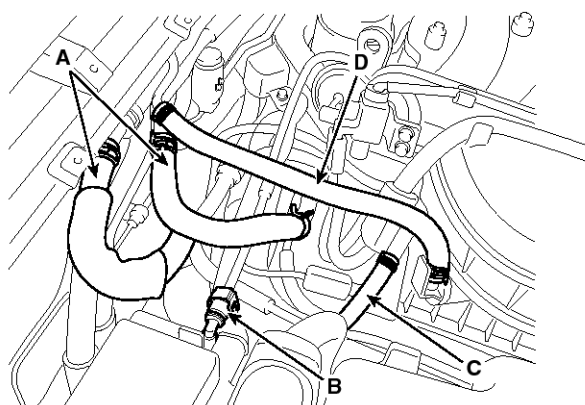

SHMEM9004L

12. Remove the engine wire harness from the fuse and relay block.

1) Remove the ECM connector (B) and the fuse and relay block cover (A).

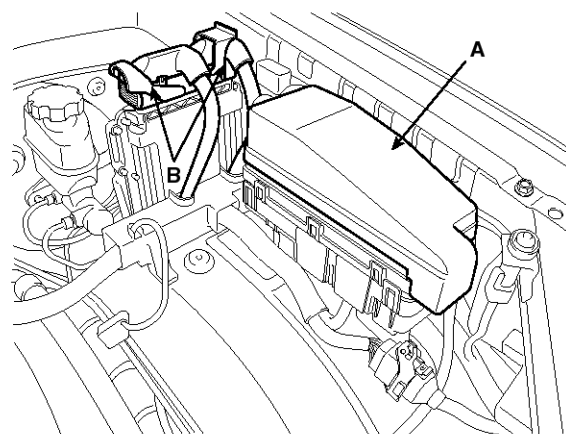

SHMEM8008D

## EM-22

## Engine Mechanical System

- 2) Remove the connectors (A) and the cable (B) from the fuse and relay block.
- 3) Remove the fuse and relay block (C).

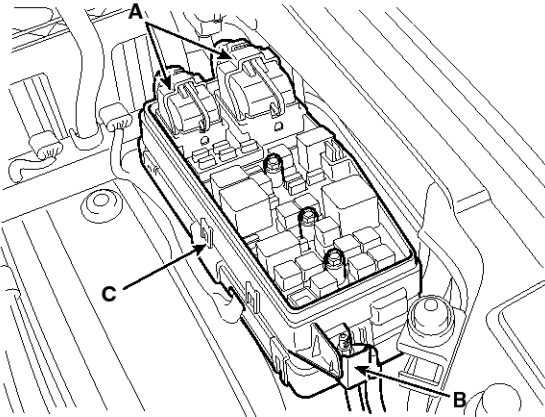

SHMM19055N

- 4) Remove the fuse and relay block connector (A) and the multi connector (B).

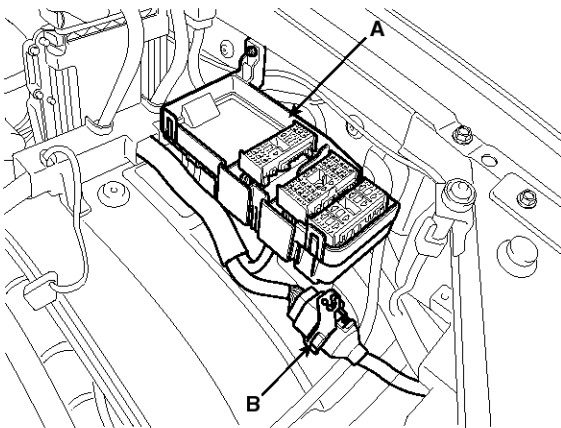

SHMEM8009D

- 5) Remove the fuse and relay block lower cover (A).

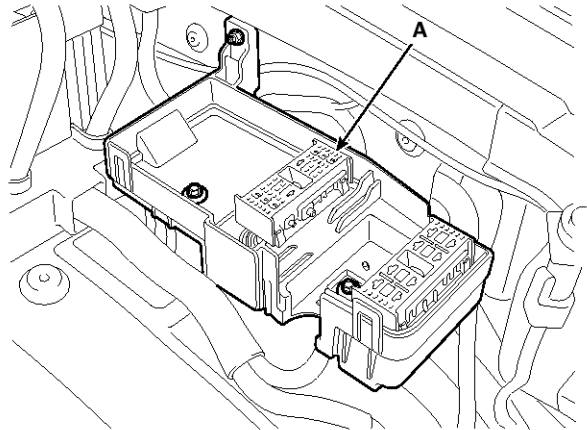

SHMM19056N

- 6) Remove the connector (A) from the fuse and relay block lower cover bracket.

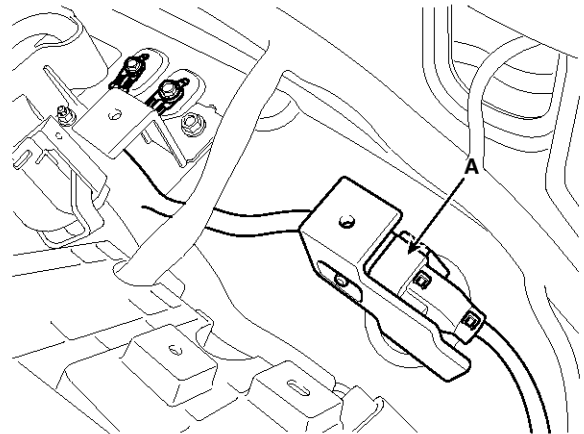

SHMM19057N

- 7) Remove the earth cable (A) and the harness protector (B).

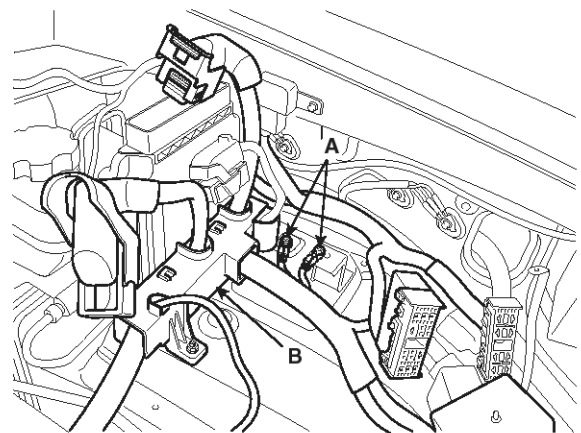

SHMEM9112L

13. Disconnect the fan connector (A) and remove the cooling fan assembly (B).

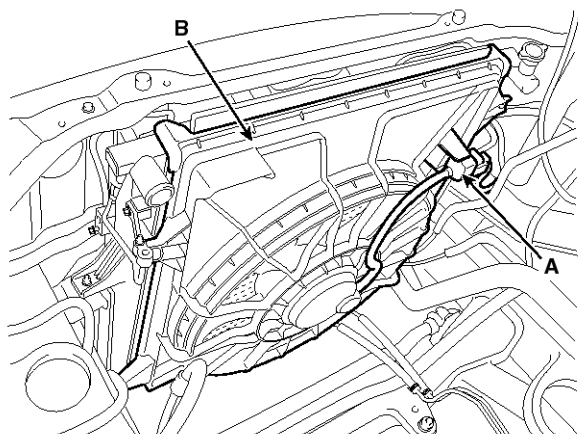

SHMEM9005L

14. Remove the air conditioner high pressure pipe (A). (Refer to HA group)

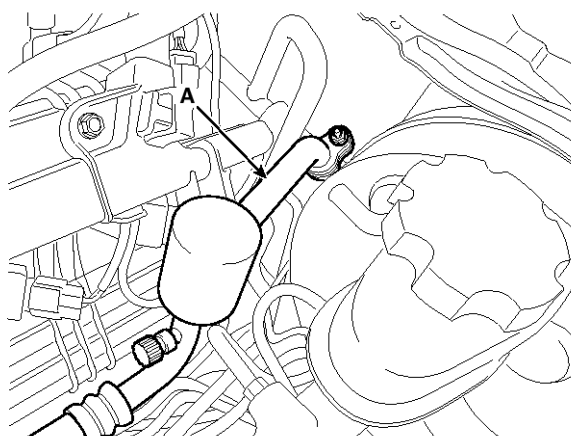

SHMM19059N

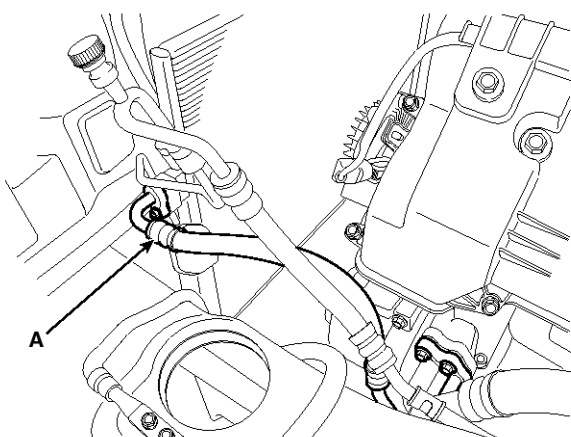

SHMM19060N

15. Disconnect the alternator connect (A), cable (B), A/C connector (C), ground cable (D) and then remove the starter protector (E).

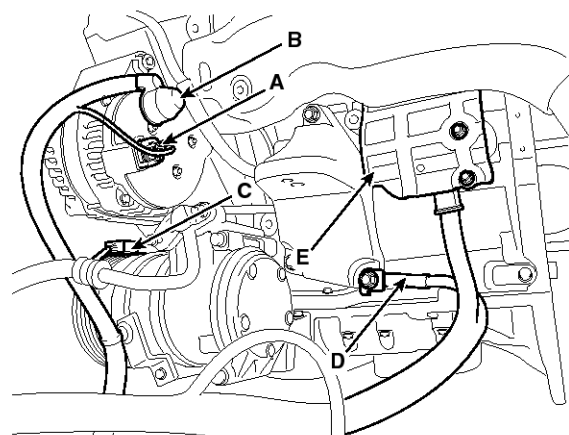

SHMEM9010L

16. Disconnect the starter connector (A), cable (B) and then remove the wiring protector.

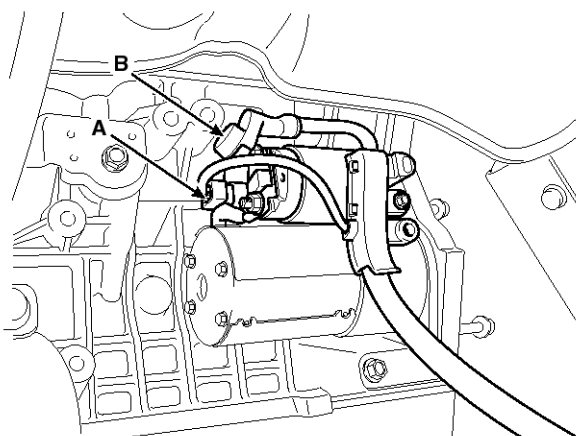

SHMEM9011L

17. Disconnect the ground cable (A).

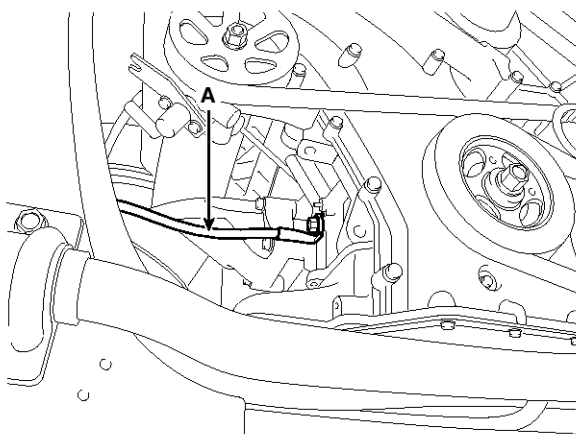

SHMEM9012L

## EM-24

## Engine Mechanical System

18. Remove the TCU (A) and disconnect the ground cable (B).

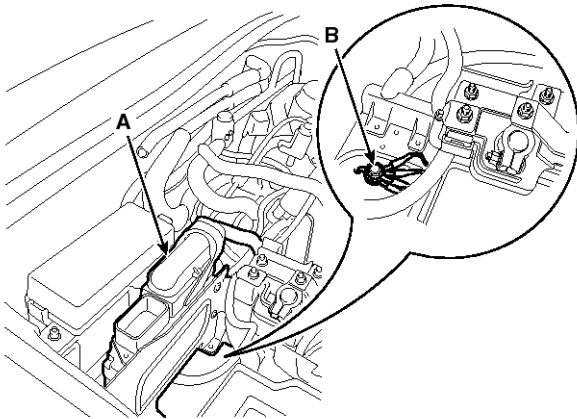

SHMEM9013L

19. Remove the engine mounting bracket nuts (A).

**Tightening torque :**

88.3 ~ 107.9N.m (9.0 ~ 11.0kgf.m, 65.1 ~ 79.6lb-ft)

[LH]

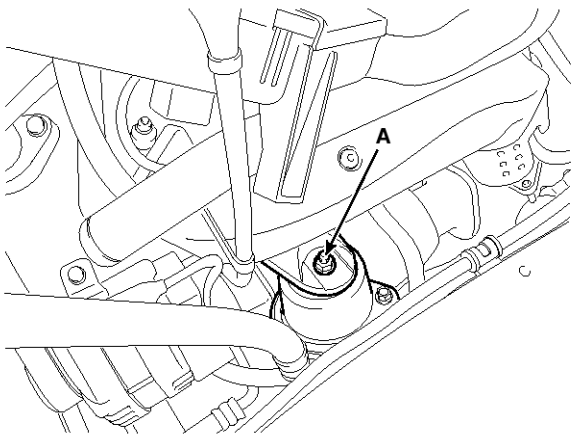

SHMEM9014L

[RH]

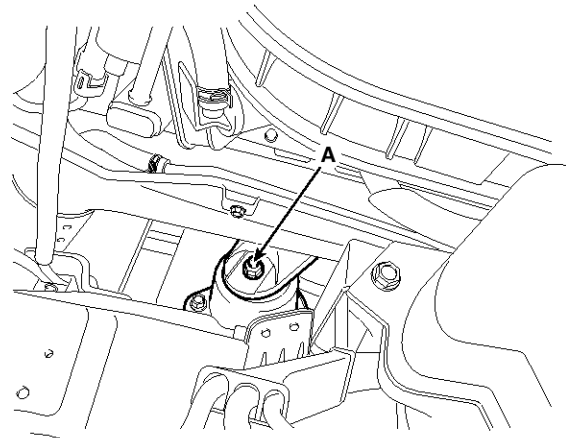

SHMEM9015L

20. Remove the engine assembly from the vehicle by using hoist.

**CAUTION**

When removing the engine assembly, be careful not to damage any surrounding parts or body components.

## Installation

Installation is in the reverse order of removal.

Perform the following :

- Adjust the shift cable.
- Refill engine with engine oil.
- Refill a transmission with fluid.
- Clean battery posts and cable terminals with sandpaper. Reassemble, then apply grease to prevent corrosion.
- Inspect for fuel leakage.
  - After assembling the fuel line, turn on the ignition switch (do not operate the starter) so that the fuel pump runs for approximately two seconds and fuel line pressurizes.
  - Repeat this operation two or three times, then check for fuel leakage at any point in the fuel line.
- Refill a radiator and a reservoir tank with engine coolant.
- Bleed air from the cooling system.
  - Start engine and let it run until it warms up. (until the radiator fan operates 3 or 4 times.)
  - Turn Off the engine. Check the level in the radiator, add coolant if needed. This will allow trapped air to be removed from the cooling system.
  - Put radiator cap on tightly, then run the engine again and check for leaks.

# EM-26

# Engine Mechanical System

## Timing System

### Timing Chain

#### Components

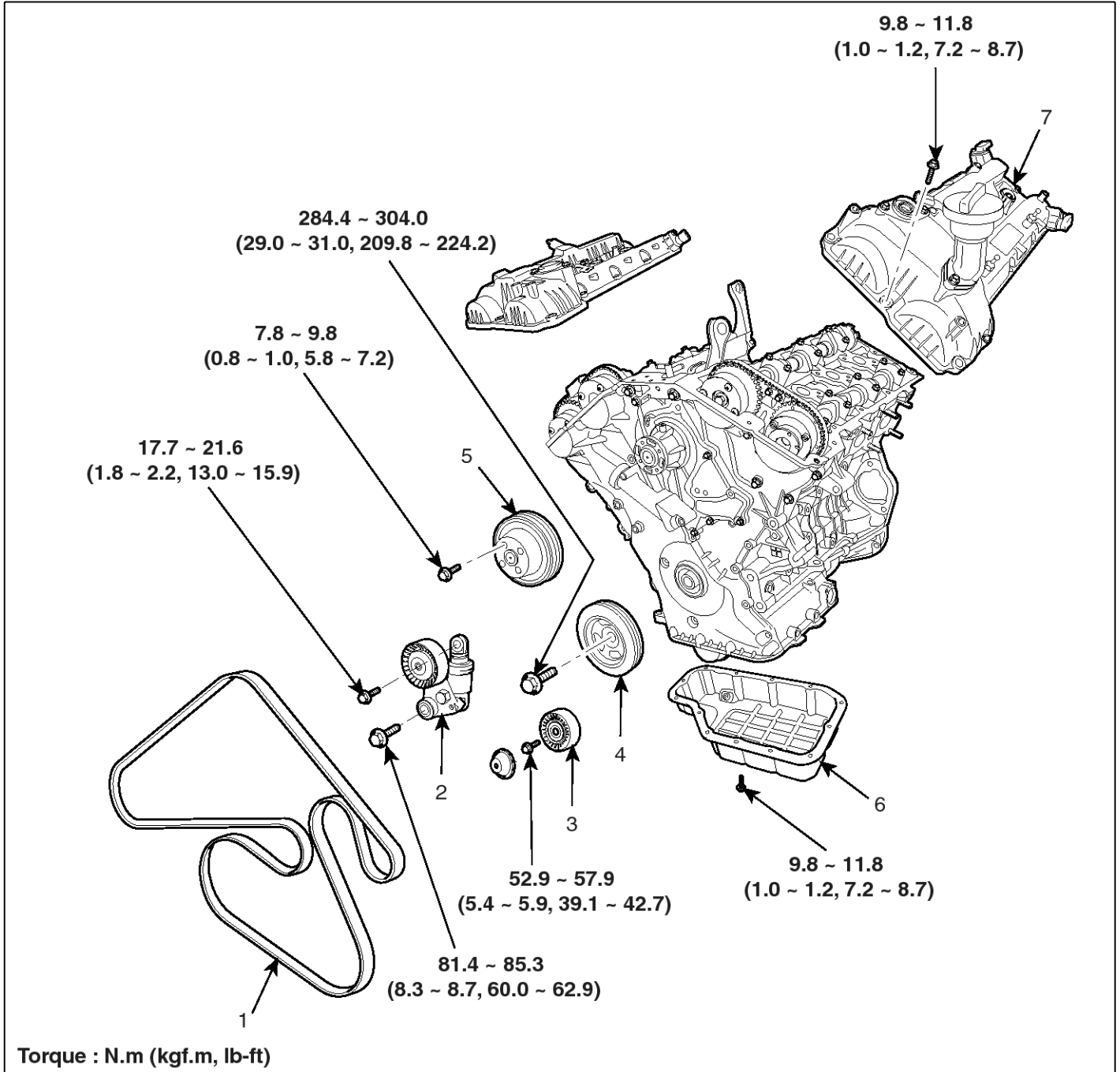

SBHEM9075L

- 1. Drive belt
- 2. Drive belt tensioner
- 3. Idler
- 4. Crank shaft pulley

- 5. Water pump pulley
- 6. Oil pan
- 7. Cylinder head cover

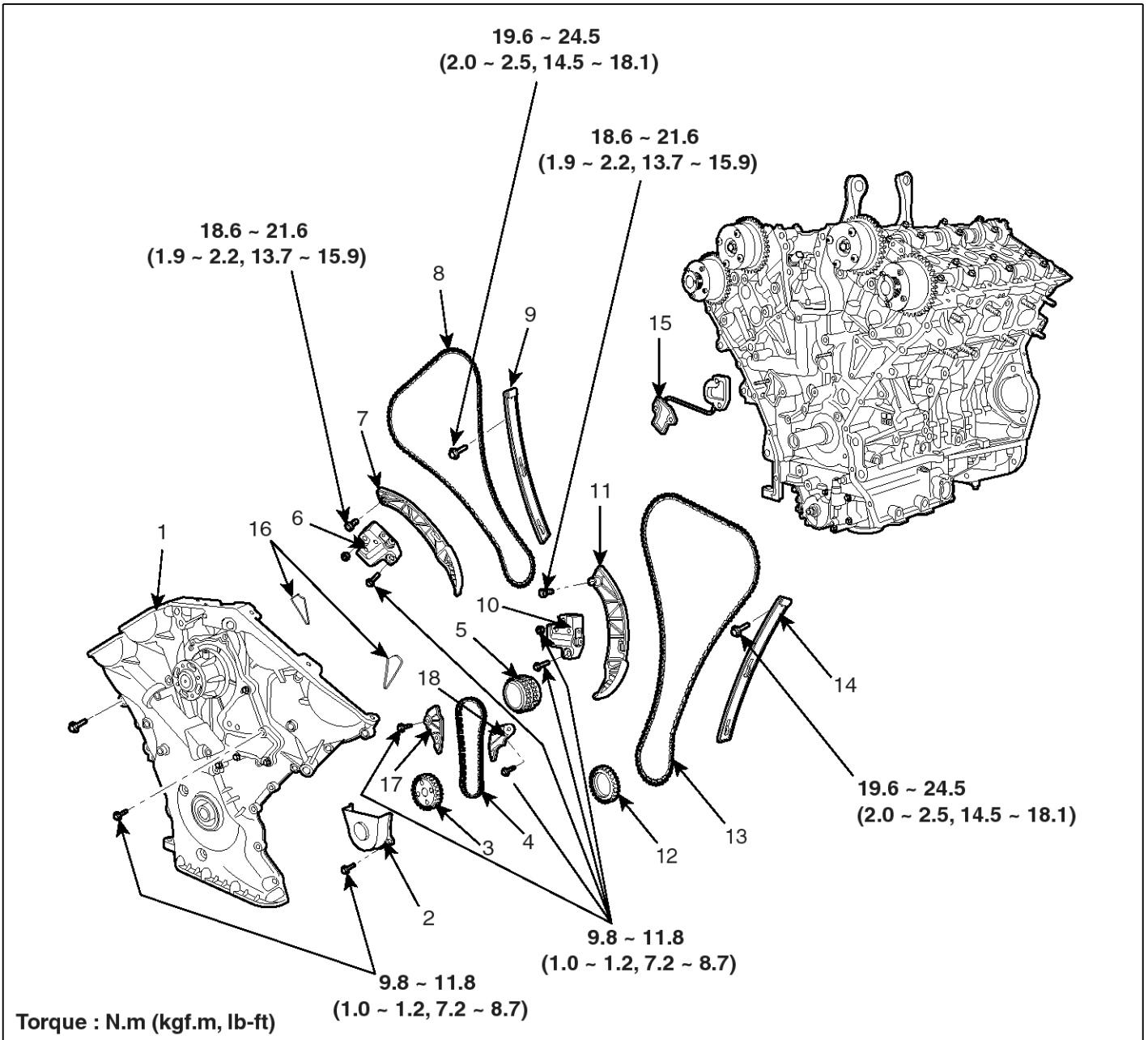

SBHEM9076L

- |                                |                                 |                                 |
|--------------------------------|---------------------------------|---------------------------------|
| 1. Timing chain cover          | 7. Timing chain tensioner arm   | 13. Timing chain                |
| 2. Oil pump chain cover        | 8. Timing chain                 | 14. Timing chain guide          |
| 3. Oil pump sprocket           | 9. Timing chain guide           | 15. Tensioner adapter           |
| 4. Oil pump chain              | 10. Timing chain auto tensioner | 16. Gasket                      |
| 5. Crankshaft sprocket         | 11. Timing chain tensioner arm  | 17. Oil pump chain guide        |
| 6. Timing chain auto tensioner | 12. Crankshaft sprocket         | 18. Oil pump tensioner assembly |

## EM-28

## Engine Mechanical System

### Removal

#### ⚠CAUTION

- Use fender covers to avoid damaging painted surfaces.
- To avoid damage, unplug the wiring connectors carefully while holding the connector portion.

#### 📌NOTICE

- Mark all wiring and hoses to avoid misconnection.
- Turn the crankshaft pulley so that the No.1 piston is at top dead center.

1. Disconnect the negative cable(A) from the battery.

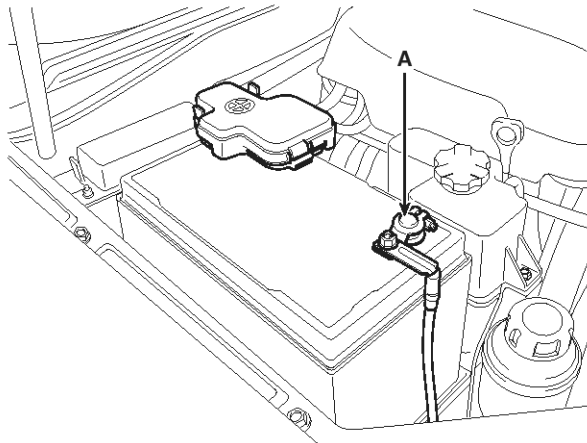

SHMM19043N

2. Loosen the drain plug and drain the engine coolant. Remove the radiator cap (A) to speed draining.

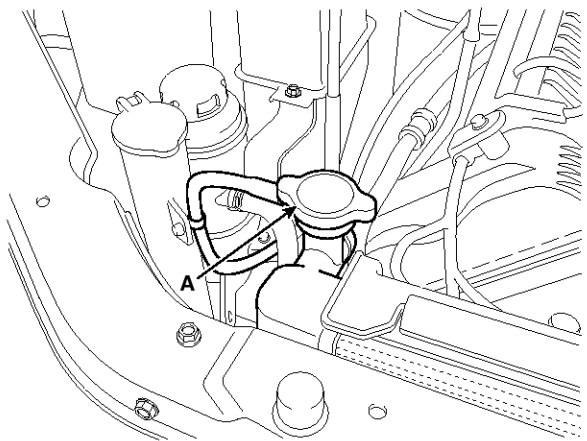

SHMM19047N

3. Remove the engine cover (A).

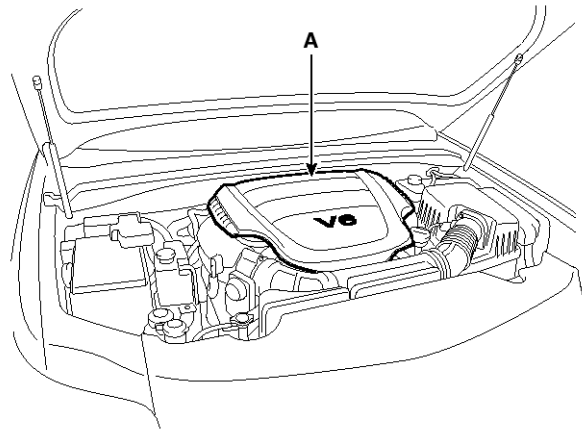

SHMEM9001L

4. Remove the radiator grill upper guard (A).

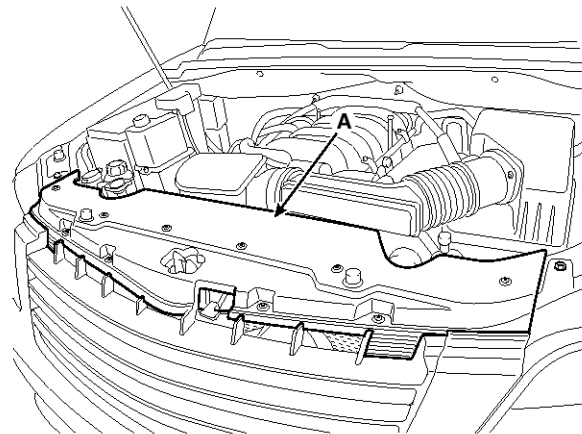

SHMM19045N

5. Disconnect the AFS connector (A) and breather hose (B) and then remove the air cleaner assembly (C).

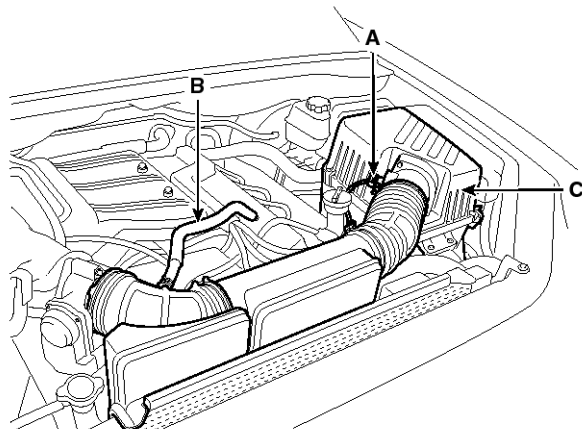

SHMEM9002L

# Timing System

# EM-29

6. Disconnect the radiator upper hose (A) and lower hose (B).

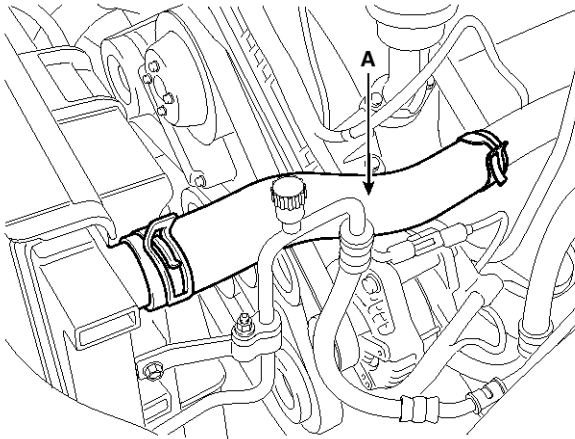

SHMEM9003L

8. Disconnect the fan connector (A) and remove the cooling fan assembly (B).

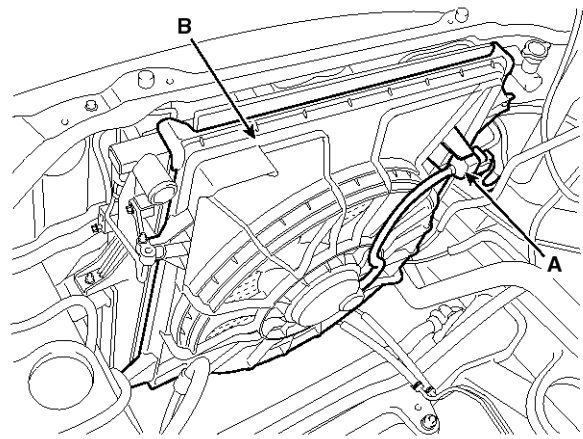

SHMEM9005L

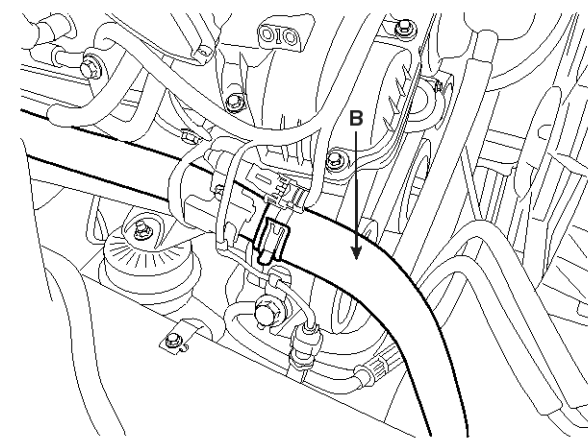

SBHEM8003D

7. Disconnect the purge control solenoid valve (PCSV) hose (A) and the brake booster vacuum hose (B).

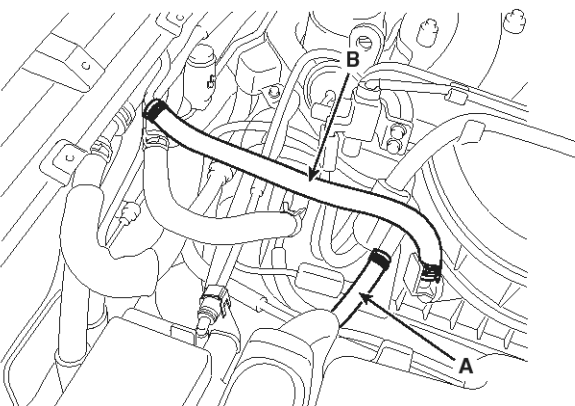

SHMEM9116L

9. Disconnect the engine wiring connectors.

- 1) Disconnect the power steering oil pressure switch connector (A) and RH knock sensor connector (B).

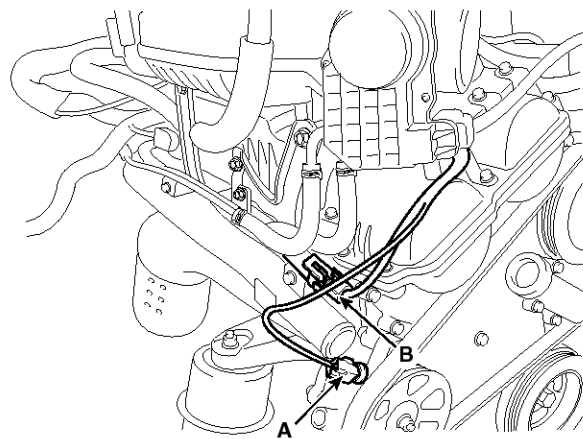

SHMEM9006L

## EM-30

## Engine Mechanical System

- 2) Disconnect the MAP sensor connector (A), ETC connector (B), RH exhaust OCV connector (C), RH injector connector (D) and RH ignition coil connector (E).

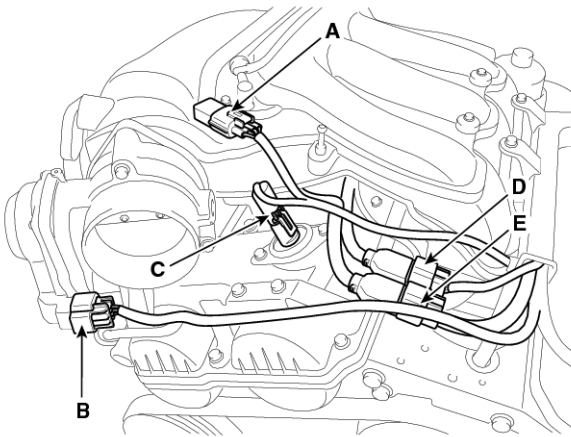

SHMEM9007L

- 3) Disconnect the LH knock sensor connector (A), LH/RH intake OCV connector (B) and LH exhaust OCV connector (C).

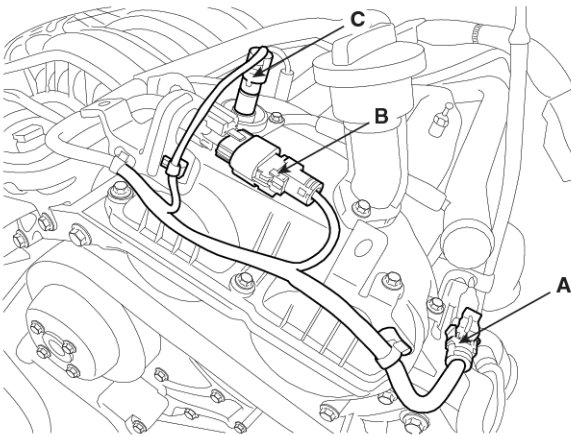

SBHEM8026D

- 4) Disconnect the LH injector connector (A) and LH ignition coil connector (B).

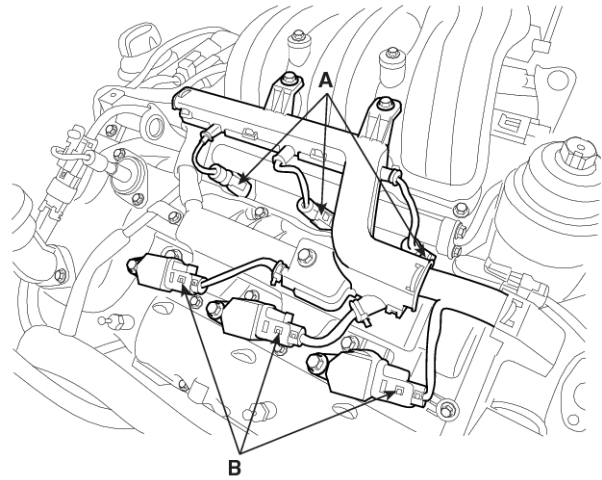

SBHEM8027D

- 5) Disconnect the oil pressure switch connector (A), LH exhaust camshaft CMP sensor connector (B) and LH oxygen sensor connector (C).

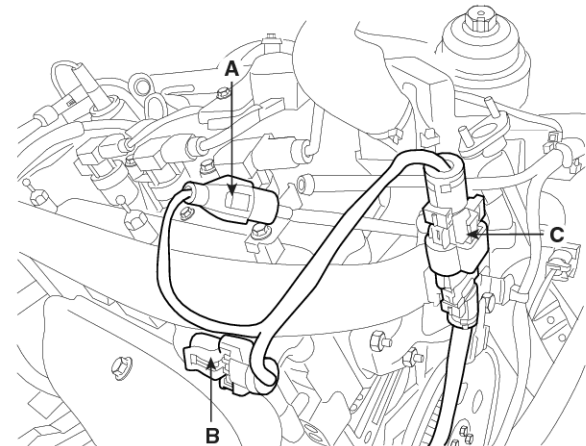

SBHEM8029D

## Timing System

## EM-31

- 6) Disconnect the LH intake camshaft CMP sensor connector (A), RH intake camshaft CMP sensor connector (B) and condenser connector (C).

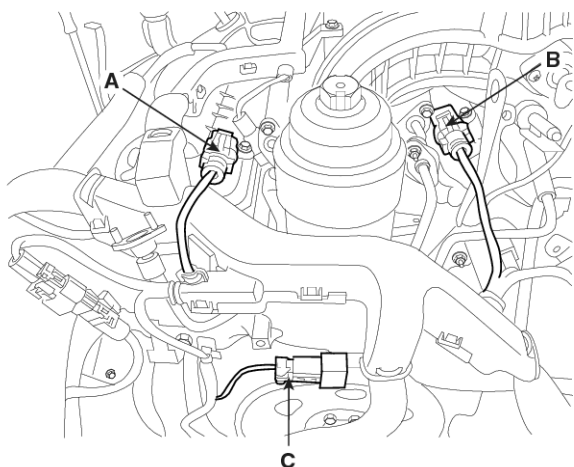

SBHEM8030D

- 7) Disconnect the VIS solenoid valve connector (A), PCSV connector (B), RH oxygen sensor connector (C) and the RH exhaust camshaft CMP sensor connector (D).

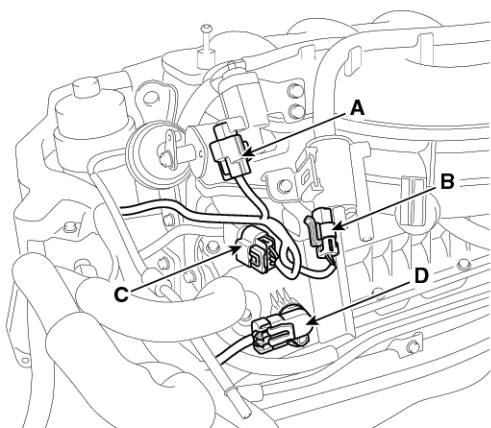

SHMEM9008L

- 8) Disconnect the water temperature sensor connector (A) and oil temperature sensor connector (B).

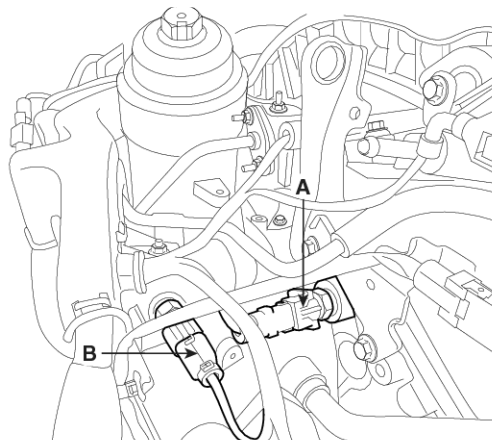

SBHEM8032D

10. Disconnect the throttle body coolant hoses (A), breather hose (B) and loosen the surge tank stay bolts (C).

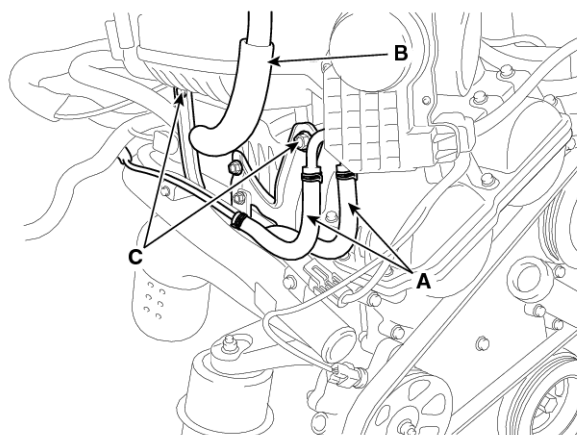

SHMEM9101L

## EM-32

## Engine Mechanical System

11. Remove the surge tank (A).

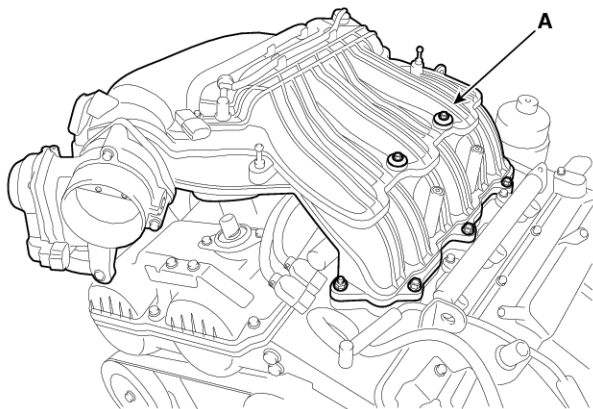

SHMEM9009L

12. Remove the coolant pipe (A).

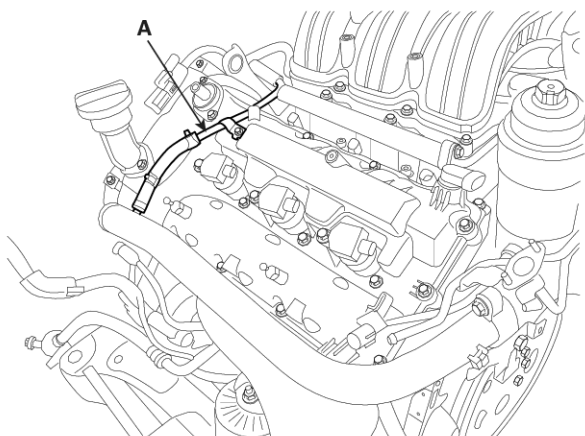

SHMEM9113L

13. Disconnect the RH ignition coil connector (A) and the injector connector (B).

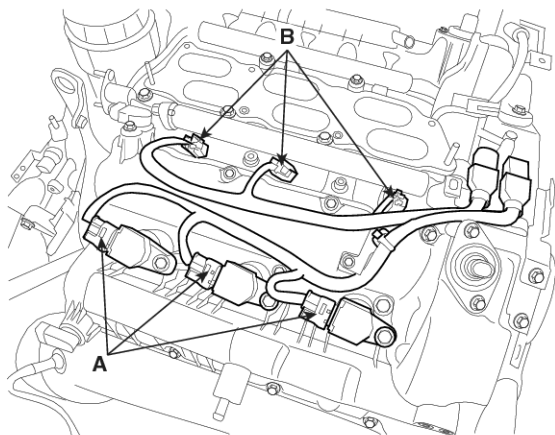

SBHEM8044D

14. Remove the LH/RH ignition coils (A).

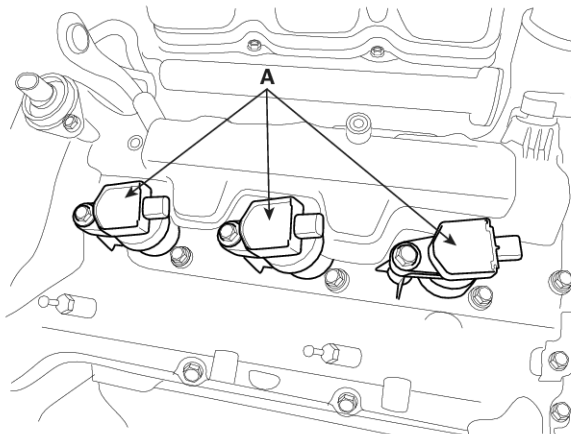

SBHEM8050D

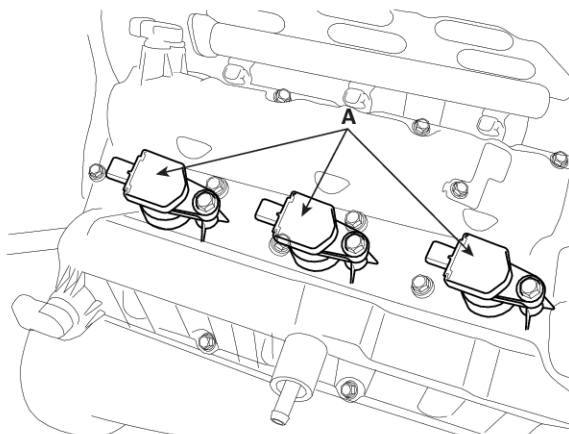

SBHEM8051D

# Timing System

15. Remove the LH/RH cylinder head cover (A).

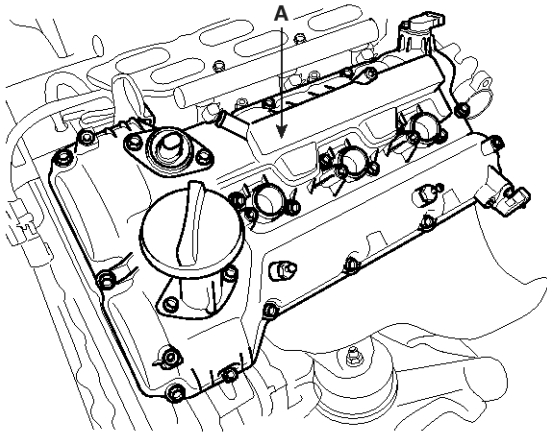

SBHEM8056D

17. Remove the drive belt idler (A).

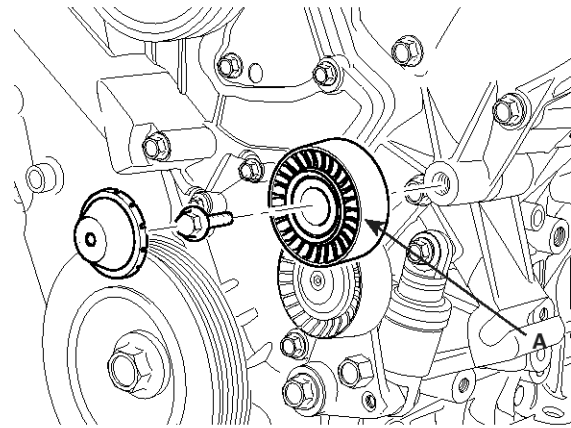

KDRF105A

18. Remove the drive belt auto tensioner (A).

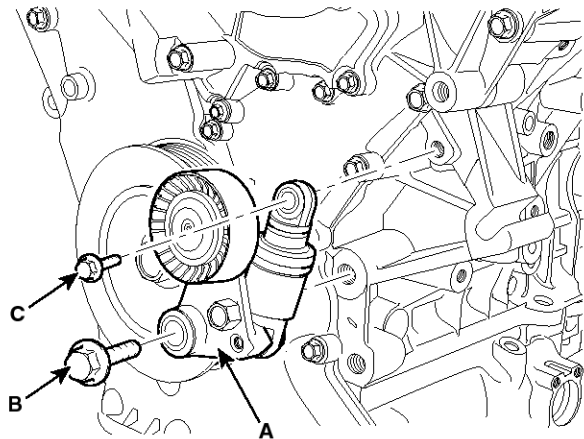

SENEM8020D

16. Remove the drive belt (A).

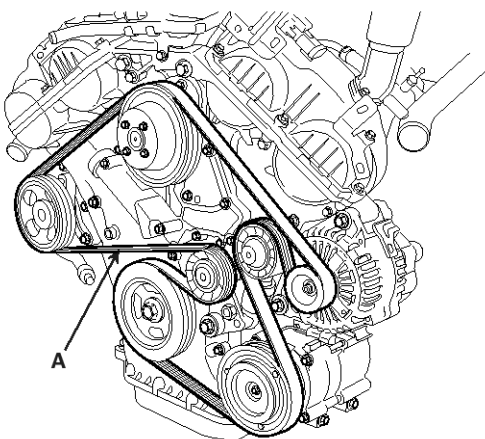

SBHEM8058D

## EM-34

## Engine Mechanical System

19. Remove the water pump pulley (A).

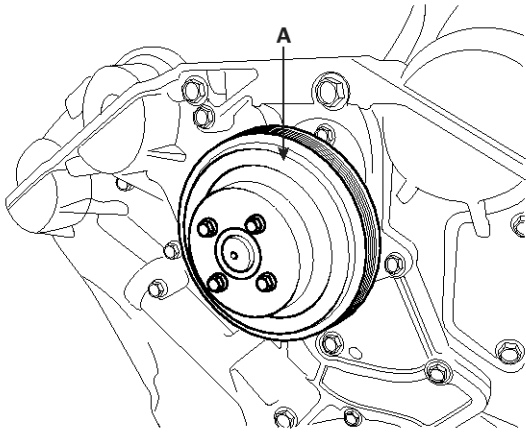

SBHEM8059D

20. Set No.1 cylinder to TDC/compression.

- 1) Turn the crankshaft pulley clockwise and align its groove with the timing mark "T" of the lower timing chain cover.

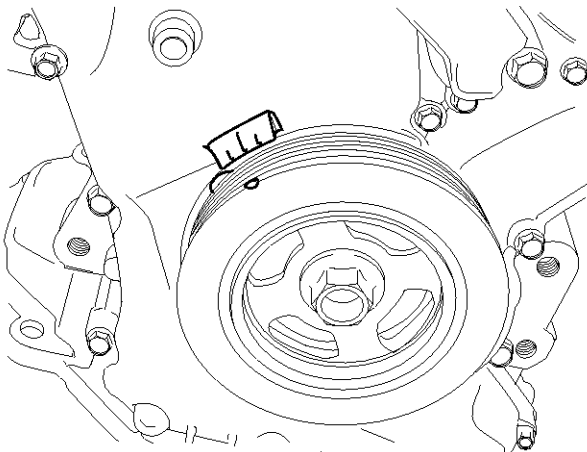

KDRF108A

- 2) Check that the mark (A) of the camshaft timing sprockets are lined up on the cylinder head surface as shown in the illustration. If not, turn the crankshaft clockwise one revolution (360°).

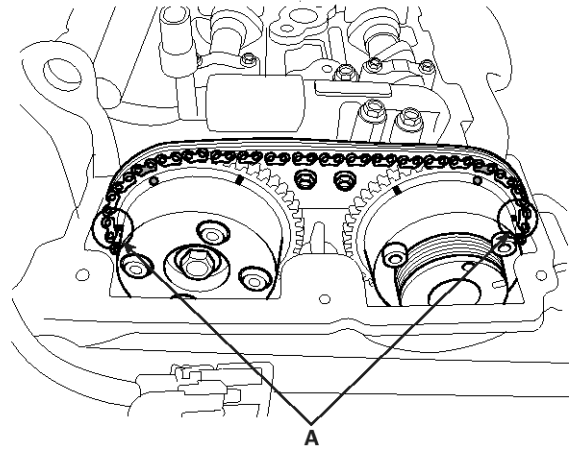

SBHEM8060D

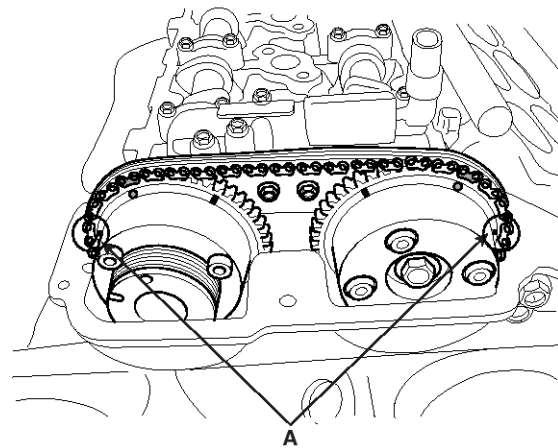

SBHEM8061D

### NOTICE

*Do not rotate engine counterclockwise.*

## Timing System

EM-35

21. Remove the lower oil pan (A).

Insert the blade of SST(09215-3C000) between the upper oil pan and lower oil pan. Cut off applied sealer and remove the lower oil pan.

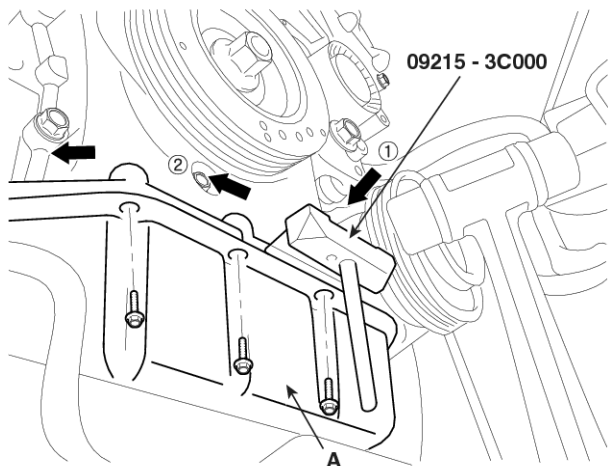

SBLM16019L

### NOTICE

- Insert the SST between the oil pan and the ladder frame by tapping it with a plastic hammer in the direction of arrow.
- After tapping the SST with a plastic hammer along the direction of arrow around more than 2/3 edge of the oil pan, remove it from the ladder frame.
- Do not turn over the SST abruptly without tapping. It be result in damage of the SST.
- Be careful not to damage the contact surfaces of Upper oil pan and lower oil pan.

22. Remove the crankshaft pulley (A).

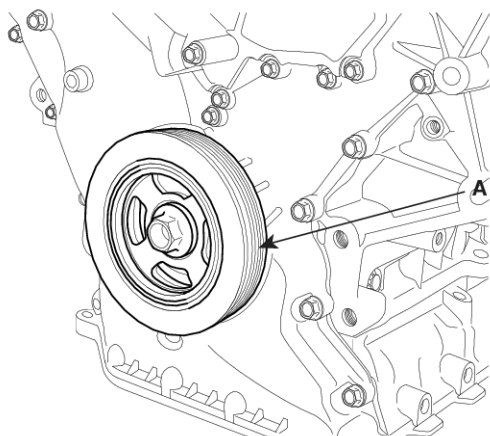

KDRF109A

### NOTICE

- Use the SST(09231-2J200, 09231-2J210) to remove the crankshaft pulley bolt.

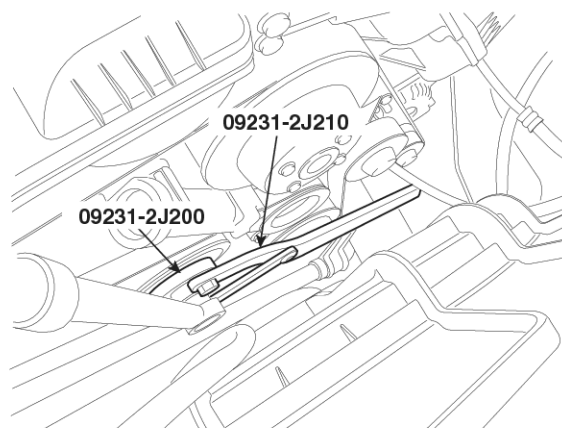

SHMM19168N

23. Remove the water vent hose (A) from the timing chain cover.

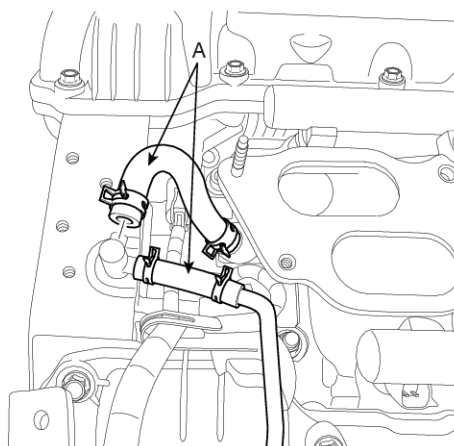

SBHEM8092D

## EM-36

## Engine Mechanical System

24. Remove the timing chain cover (A).

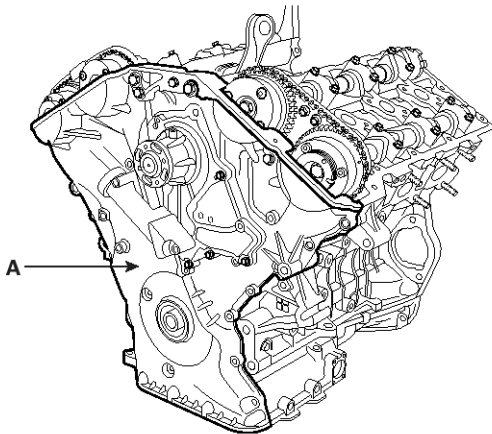

SBHEM8064D

### ⚠ CAUTION

- Be careful not to damage the contact surfaces of cylinder block, cylinder head and timing chain cover.

### 📄 NOTICE

- Before removing the timing chain, mark the RH/LH timing chain with an identification based on the location of the sprocket because the identification mark on the chain for TDC (Top Dead Center) can be erased.

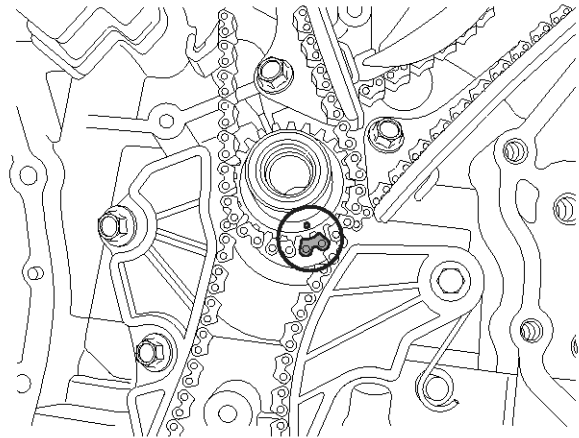

KDRF129A

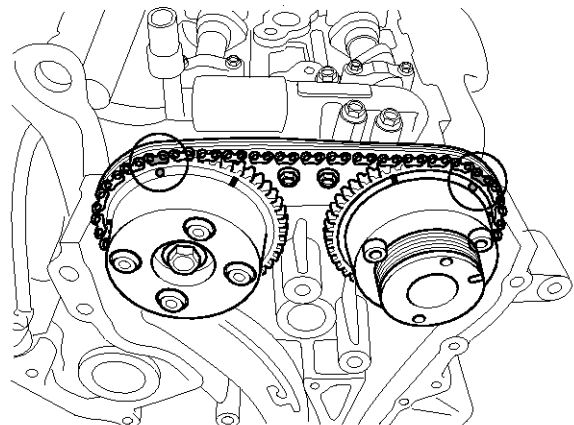

SBHEM8062D

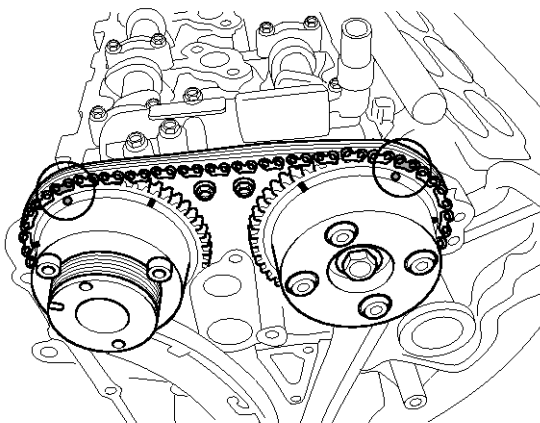

SBHEM8063D

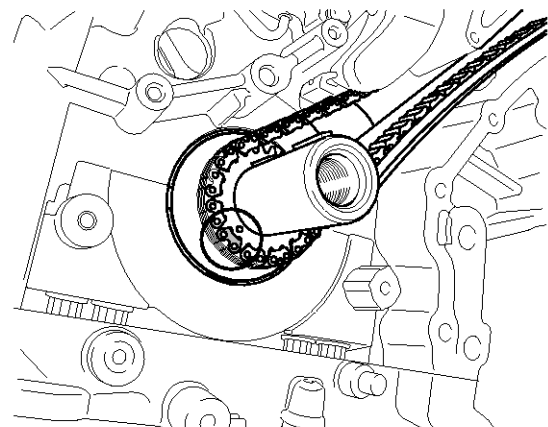

SBHEM8074D

# Timing System

# EM-37

25. Remove the oil pump chain cover (A).

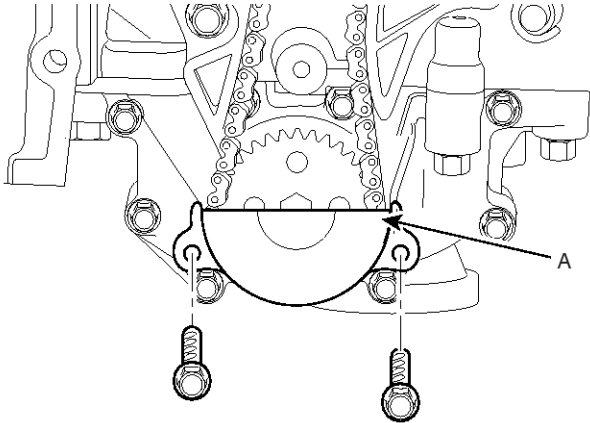

SBHEM8209D

26. Remove the oil pump chain tensioner assembly (A).

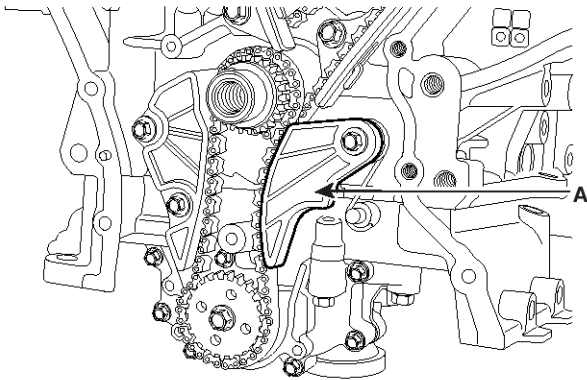

KDRF119A

27. Remove the oil pump chain guide (A).

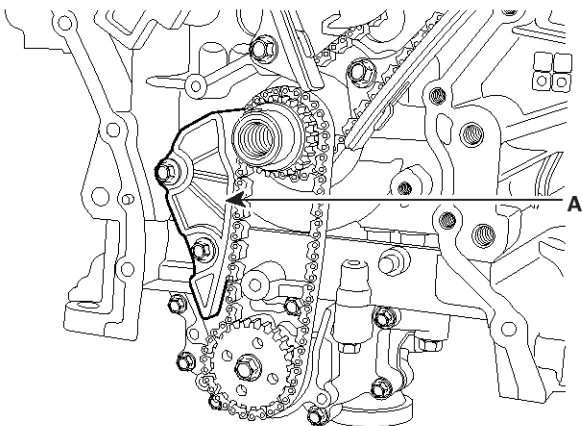

KDRF120A

28. Install a set pin after compressing the RH timing chain tensioner.

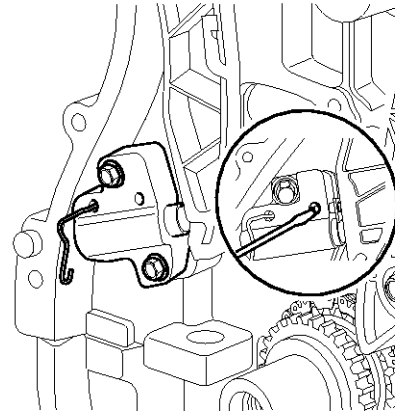

KCRF105A

29. Remove the RH timing chain auto tensioner (A) and the RH timing chain tensioner arm (B).

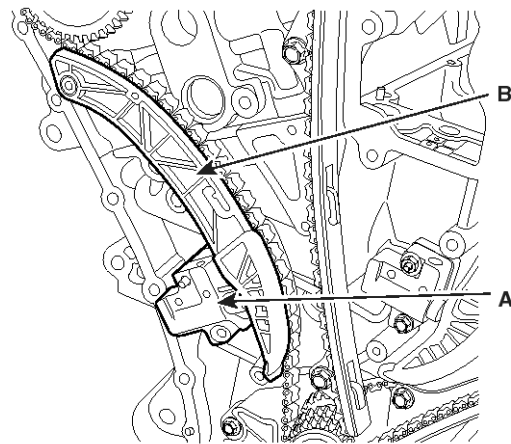

KDRF117A

## EM-38

## Engine Mechanical System

30. Remove the RH timing chain guide (A) and RH timing chain (B).

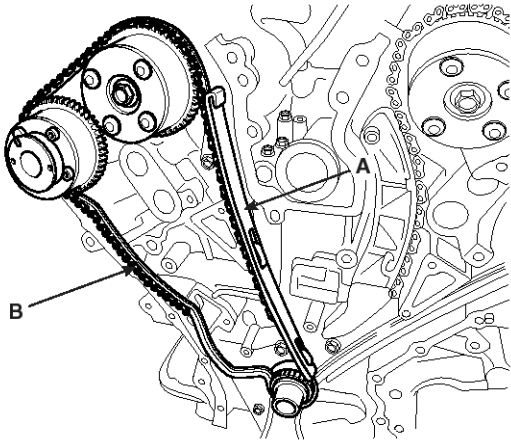

SBHEM8065D

31. Remove the oil pump chain sprocket (A) and oil pump chain (B).

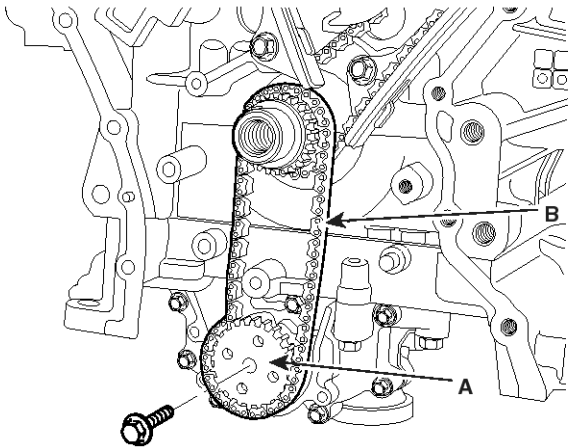

KDRF121A

32. Remove the crankshaft sprocket (A) (O/P & RH camshaft drive).

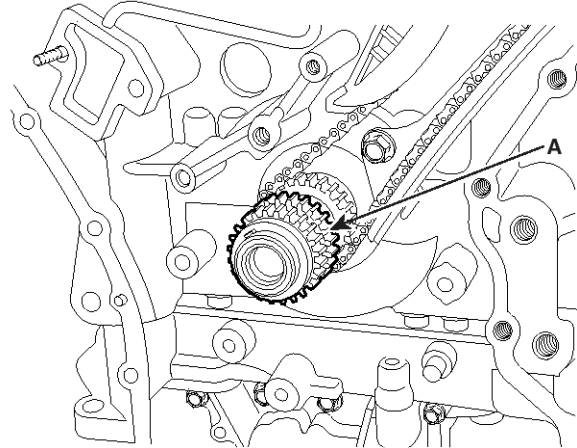

KDRF122A

33. Install a set pin after compressing the LH timing chain tensioner.

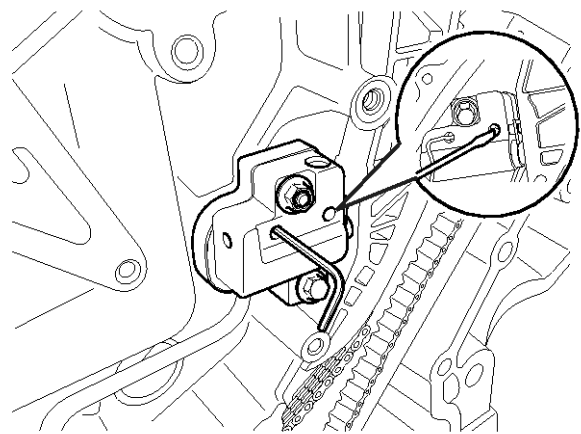

SBHEM8066D

# Timing System

34. Remove the LH timing chain auto tensioner (A) and LH timing chain tensioner arm (B).

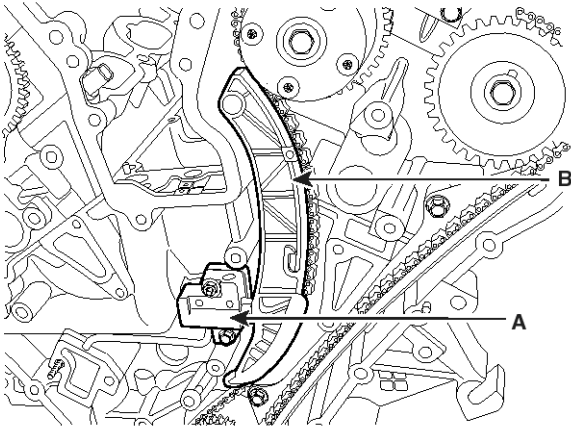

KDRF124A

35. Remove the LH timing chain guide (A) and LH timing chain (B).

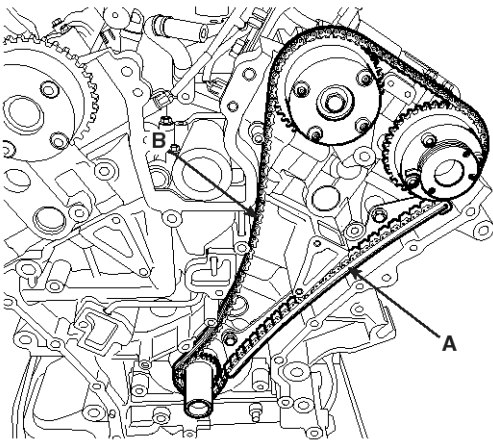

SBHEM8067D

36. Remove the crankshaft sprocket (A). (LH camshaft drive).

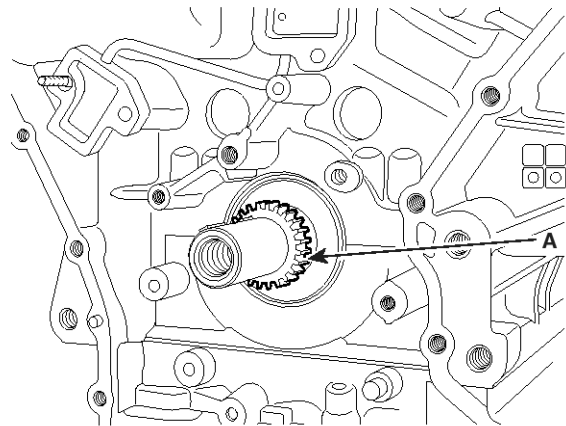

KDRF126A

37. Remove the tensioner adapter assembly (A).

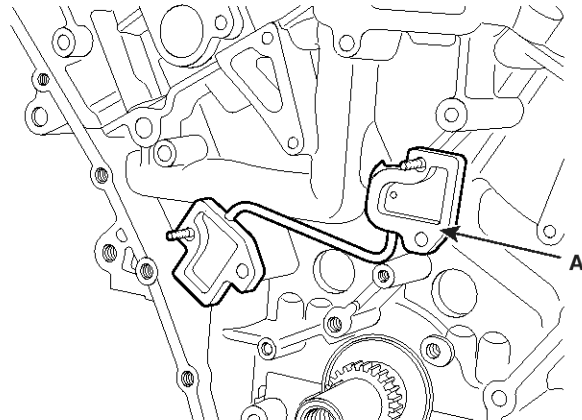

KDRF127A

## EM-40

## Engine Mechanical System

### Inspection

#### Sprockets, Chain Tensioner, Chain Guide, Chain Tensioner Arm

1. Check the camshaft sprocket and crankshaft sprocket for abnormal wear, cracks, or damage. Replace as necessary.
2. Inspect the tensioner arm and chain guide for abnormal wear, cracks, or damage. Replace as necessary.
3. Check that the tensioner piston moves smoothly when the ratchet pawl is released with thin rod.

### Installation

1. The key (A) of crankshaft should be aligned with the timing mark (B) of timing chain cover. As a result of this, the piston of No.1 cylinder is placed at the top dead center on compression stroke.

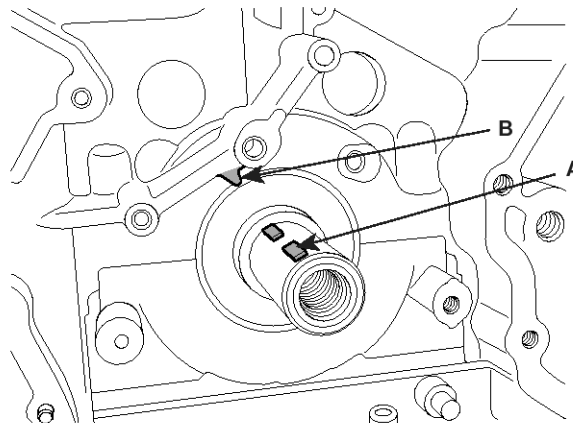

KDRF128A

2. Install the tensioner adapter assembly (A).

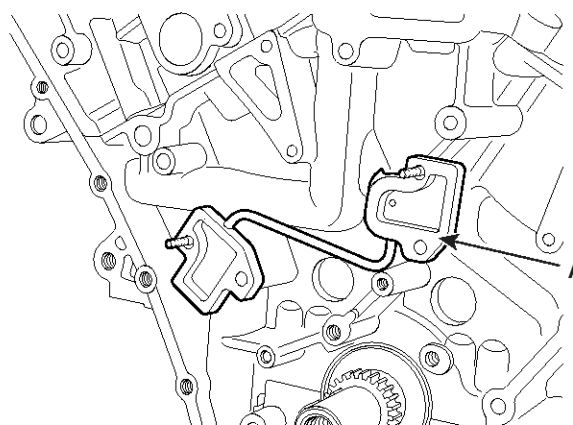

KDRF127A

# Timing System

3. Install the crankshaft sprocket (A). (LH camshaft drive).

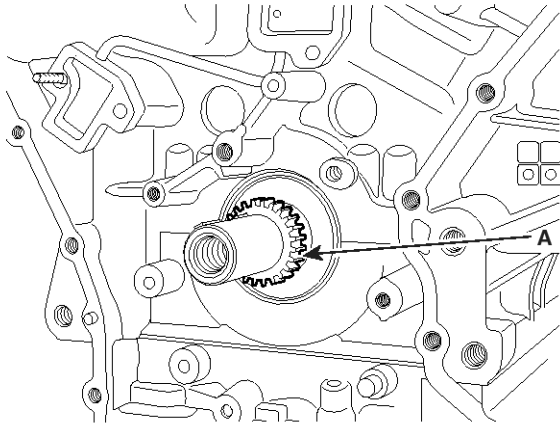

KDRF126A

4. Install the LH timing chain (B) and the LH timing chain guide (A).

**Tightening torque :**

19.6 ~ 24.5N.m (2.0 ~ 2.5kgf.m, 14.5 ~ 18.1lb-ft)

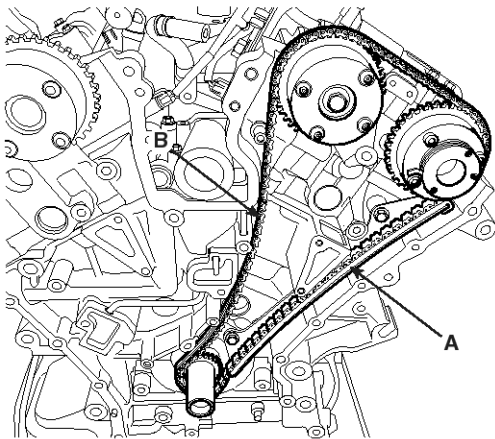

SBHEM8067D

**NOTICE**

To install the timing chain with no slack between each shaft (cam, crank), perform the following procedure.

Crankshaft sprocket → Timing chain guide → Exhaust camshaft sprocket → Intake camshaft sprocket.

The timing mark of each sprockets should be matched with timing mark (color link) of timing chain at during installation.

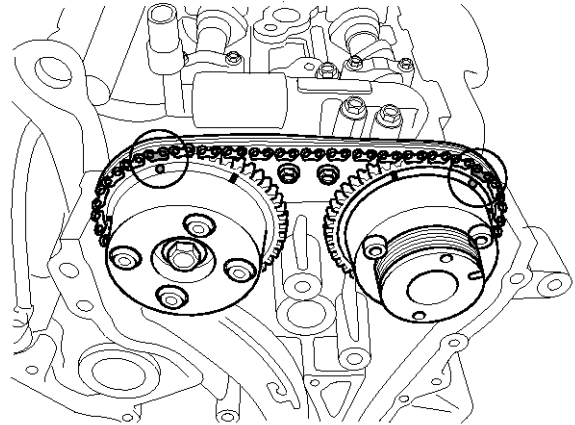

SBHEM8062D

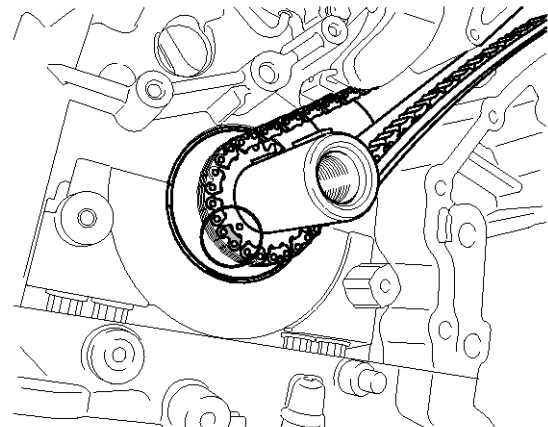

SBHEM8074D

## EM-42

## Engine Mechanical System

5. Install the LH timing chain tensioner arm (B) and the LH timing auto tensioner (A).

### Tightening torque

A : 9.8 ~ 11.8N.m (1.0 ~ 1.2kgf.m, 7.2 ~ 8.7lb-ft)

B : 18.6 ~ 21.6N.m (1.9 ~ 2.2kgf.m, 13.7 ~ 15.9lb-ft)

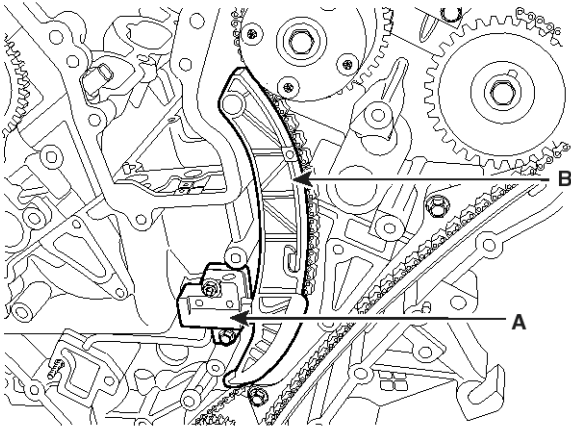

KDRF124A

6. Install the crankshaft sprocket (A) (O/P & RH camshaft drive).

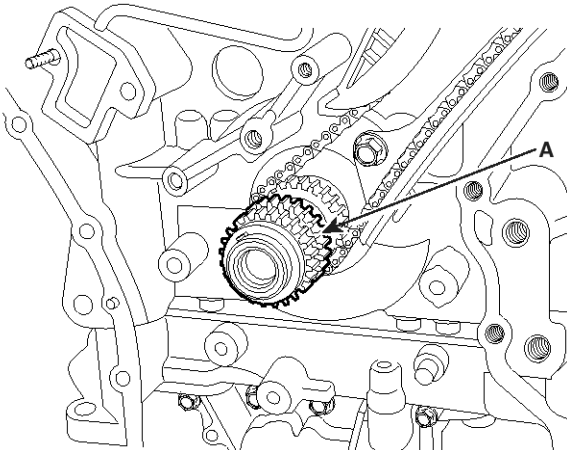

KDRF122A

7. Install the oil pump chain sprocket (A) and oil pump chain (B).

### Tightening torque :

18.6 ~ 21.6N.m (1.9 ~ 2.2kgf.m, 13.7 ~ 15.9lb-ft)

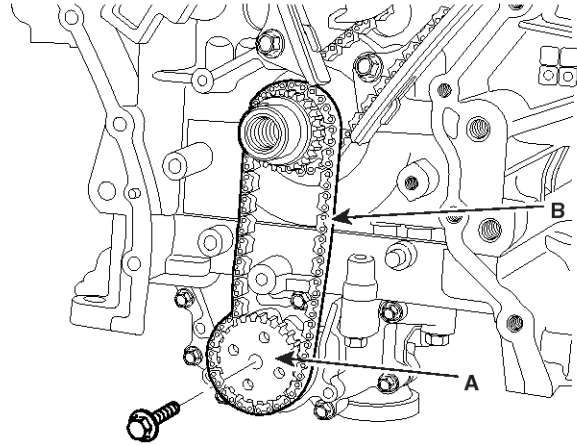

KDRF121A

8. Install the RH timing chain (B) and the RH timing chain guide (A).

### Tightening torque :

A : 19.6 ~ 24.5N.m (2.0 ~ 2.5kgf.m, 14.5 ~ 18.1lb-ft)

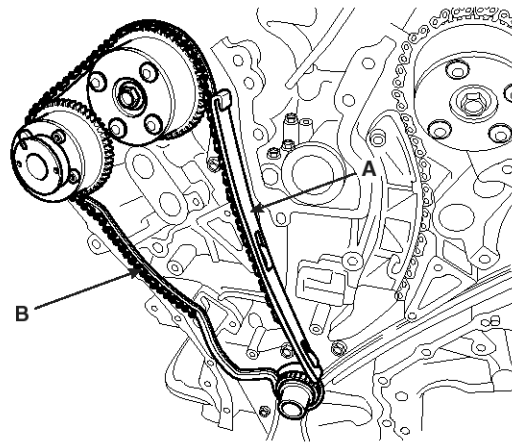

SBHEM8065D

# Timing System

## NOTICE

To install the timing chain with no slack between each shaft (cam, crank), perform the following procedure.

Crankshaft sprocket → Timing chain guide → Intake camshaft sprocket → Exhaust camshaft sprocket.

The timing mark of each sprockets should be matched with timing mark (color link) of timing chain at during installation.

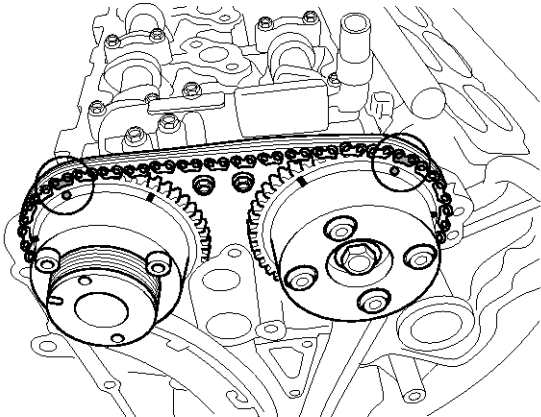

SBHEM8063D

9. Install the RH timing chain tensioner arm (B) and the RH timing auto tensioner (A).

### Tightening torque

A : 9.8 ~ 11.8N.m (1.0 ~ 1.2kgf.m, 7.2 ~ 8.7lb-ft)

B : 18.6 ~ 21.6N.m (1.9 ~ 2.2kgf.m, 13.7 ~ 15.9lb-ft)

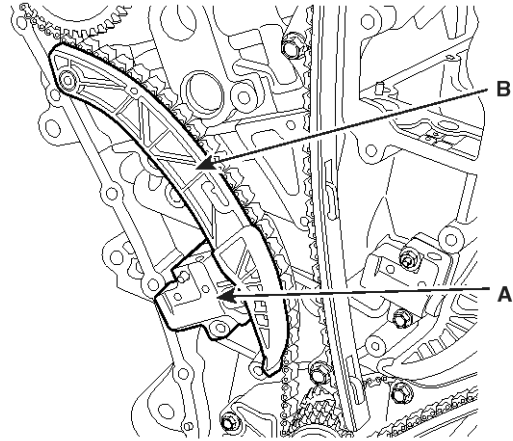

KDRF117A

10. Install the oil pump chain guide (A).

### Tightening torque :

9.8 ~ 11.8N.m (1.0 ~ 1.2kgf.m, 7.2 ~ 8.7lb-ft)

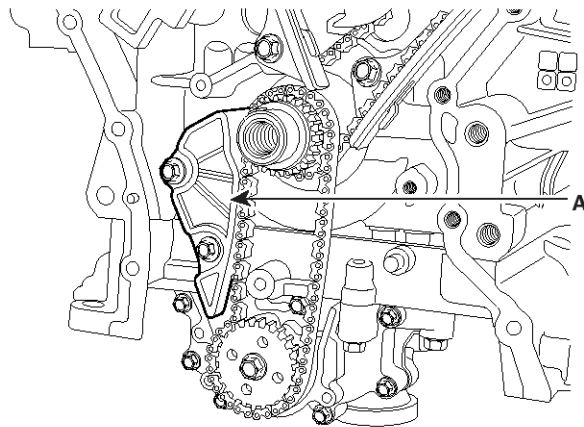

KDRF120A



KDRF129A

## EM-44

## Engine Mechanical System

11. Install the oil pump chain tensioner assembly (A).

**Tightening torque :**

9.8 ~ 11.8N.m (1.0 ~ 1.2kgf.m, 7.2 ~ 8.7lb-ft)

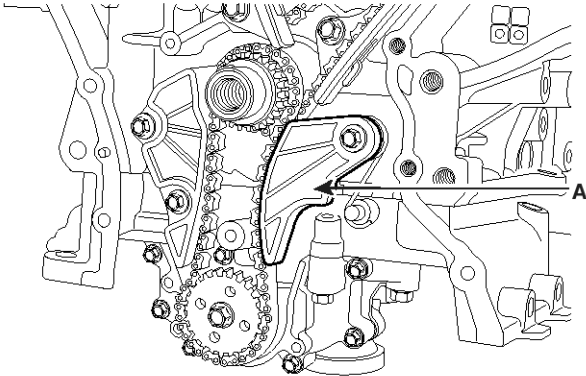

KDRF119A

12. Pull out the pins of hydraulic tensioner (LH & RH).

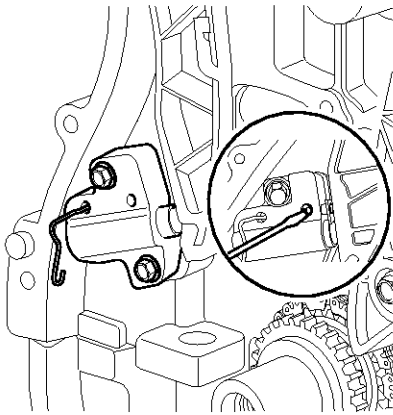

KCRF105A

13. Install the oil pump chain cover (A).

**Tightening torque :**

9.8 ~ 11.8N.m (1.0 ~ 1.2kgf.m, 7.2 ~ 8.7lb-ft)

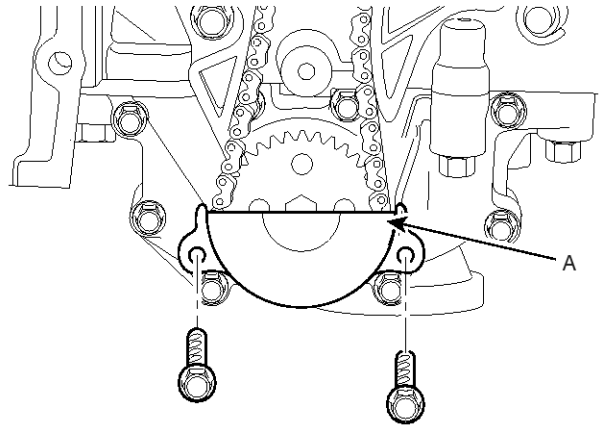

SBHEM8209D

14. After rotating the crankshaft 2 revolutions in regular direction (clockwise viewed from front), confirm the timing mark.

**NOTICE**

*Always turn the crankshaft clockwise.*

*Turning the crankshaft counter clockwise before building up oil pressure in the hydraulic timing chain tensioner may result in the chain disengaging from the sprocket teeth.*

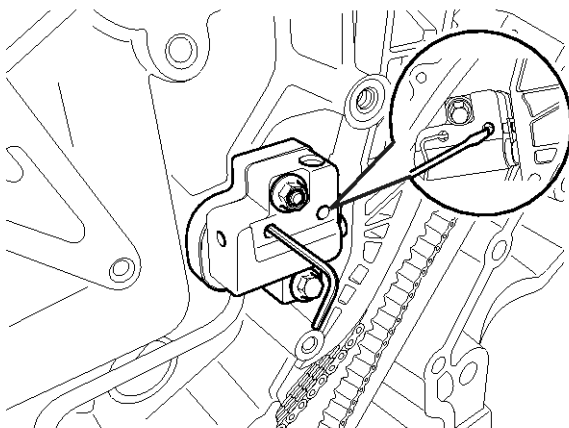

SBHEM8066D

# Timing System

# EM-45

15. Install the timing chain cover.

- 1) The sealant locations on chain cover and on counter parts (cylinder head, cylinder block, and lower oil pan) must be free of engine oil and etc.
- 2) Before assembling the timing chain cover, the liquid sealant TB 1217H should be applied on the gap between cylinder head and cylinder block.  
The part must be assembled within 5 minutes after sealant was applied.

**Bead width : 2.5mm(0.1in.)**

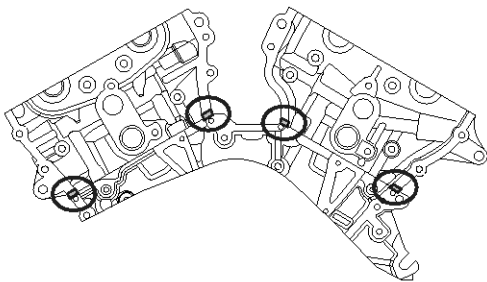

KDRF134A

- 3) After applying liquid sealant TB1217H on timing chain cover. The part must be assembled within 5 minutes after sealant was applied.  
Sealant should be applied in a continuous bead in each of the areas indicated below.

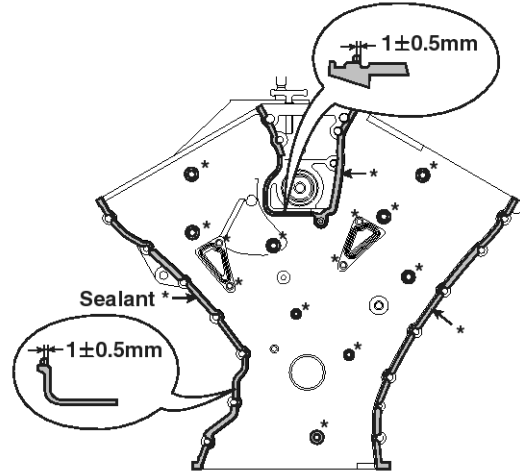

SNFM18033N

- 4) Install the new gasket (A) to the timing chain cover.

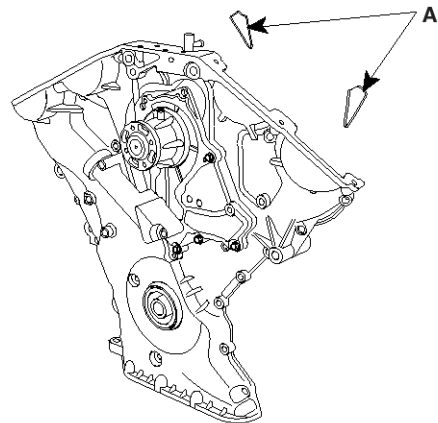

SBHEM8093D

### **NOTICE**

*During timing cover installation, care not to take off applied sealant on the timing cover by contact with other parts.*

## EM-46

## Engine Mechanical System

- 5) The dowel pins on the cylinder block and holes on the timing chain cover should be used as a reference in order to assemble the timing chain cover correctly.

### Tightening torque

- B(17) :  
18.62 ~ 21.56N.m (1.9 ~ 2.2kgf.m, 13.74 ~ 15.91lb-ft)  
C(4) :  
9.80 ~ 11.76N.m (1.0 ~ 1.2kgf.m, 7.23 ~ 8.68lb-ft)  
D(2) :  
58.80 ~ 68.80N.m (6.0 ~ 7.0kgf.m, 43.40 ~ 50.63lb-ft)  
F(2) :  
24.50 ~ 26.46N.m (2.5 ~ 2.7kgf.m, 18.08 ~ 19.53lb-ft)  
G(4) :  
21.56 ~ 23.52N.m (2.2 ~ 2.4kgf.m, 15.91 ~ 17.36lb-ft)  
H(1) :  
9.80 ~ 11.76N.m (1.0 ~ 1.2kgf.m, 7.23 ~ 8.68lb-ft)  
I(1) :  
9.80 ~ 11.76N.m (1.0 ~ 1.2kgf.m, 7.23 ~ 8.68lb-ft)  
J(1) :  
9.80 ~ 11.76N.m (1.0 ~ 1.2kgf.m, 7.23 ~ 8.68lb-ft)  
K(4) :  
9.80 ~ 11.76N.m (1.0 ~ 1.2kgf.m, 7.23 ~ 8.68lb-ft)  
L(1) :  
21.56 ~ 26.46N.m (2.2 ~ 2.7kgf.m, 15.91 ~ 19.53lb-ft)  
- New bolt

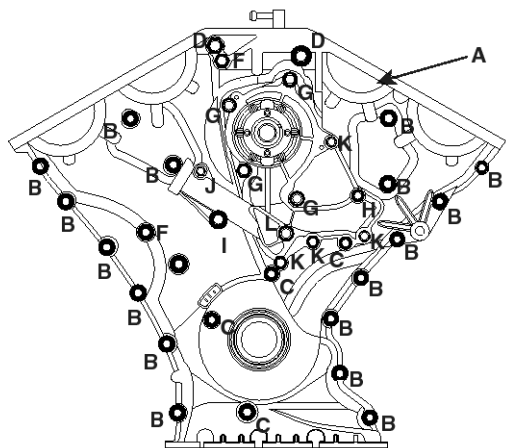

SBHEM8094D

- 6) The firing and/or blow out test should not be performed within 30 minutes after the timing chain cover was assembled.

16. Install the water vent hose (A) to the timing chain cover.

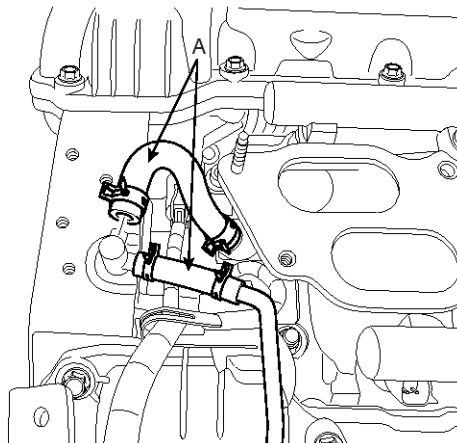

SBHEM8092D

17. Using SST(09231-3C100), install timing chain cover oil seal.

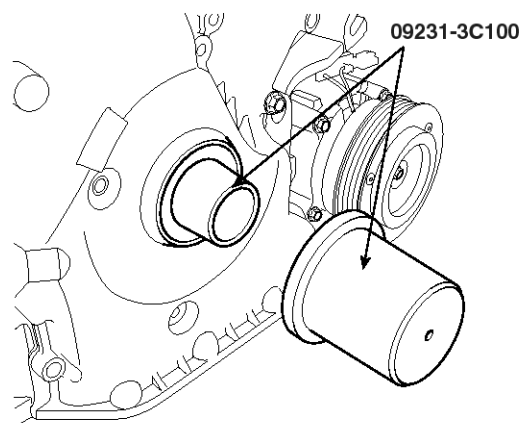

SENEM8026D

## Timing System

EM-47

18. Install the lower oil pan (A).

- 1) Using a gasket scraper, remove all the old packing material from the gasket surfaces.
- 2) Before assembling the oil pan, the liquid sealant TB 1217H should be applied on oil pan. The part must be assembled within 5 minutes after the sealant was applied.

**Bead width : 2.5mm(0.1in.)**

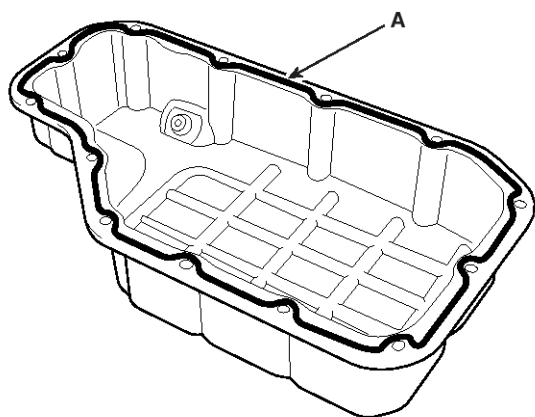

SBLM16020L

### ⚠ CAUTION

- Clean the sealing face before assembling two parts.
- Remove harmful foreign matters on the sealing face before applying sealant.
- When applying sealant gasket, sealant must not be protruded into the inside of oil pan.
- To prevent leakage of oil, apply sealant gasket to the inner threads of the bolt holes.

3) Install the oil pan (A).

Uniformly tighten the bolts in several passes.

### Tightening torque :

9.8 ~ 11.8N.m (1.0 ~ 1.2kgf.m, 7.2 ~ 8.7lb-ft)

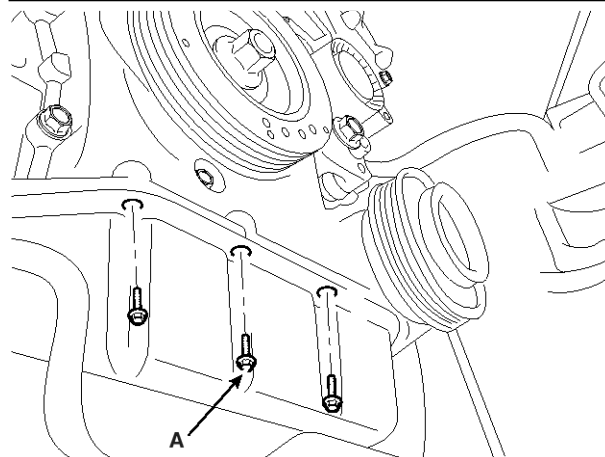

SBLM16102L

19. Install the crankshaft pulley (A).

### Tightening torque :

284.4 ~ 304.0N.m (29.0~31.0kgf.m, 209.8~224.2lb-ft)

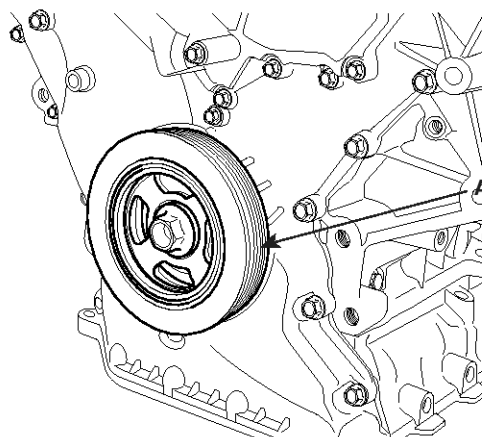

KDRF109A

## EM-48

## Engine Mechanical System

### NOTICE

- Use the SST(09231-2J200, 09231-2J210) to install the crankshaft pulley bolt.

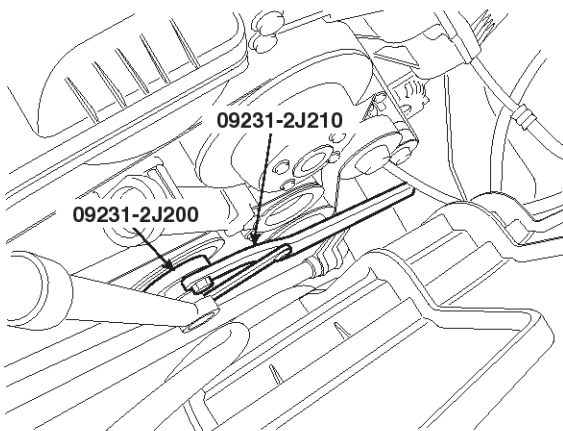

SHMM19168N

20. Install the water pump pulley (A).

### Tightening torque :

7.8 ~ 9.8N.m (0.8 ~ 1.0kgf.m, 5.8 ~ 7.2lb-ft)

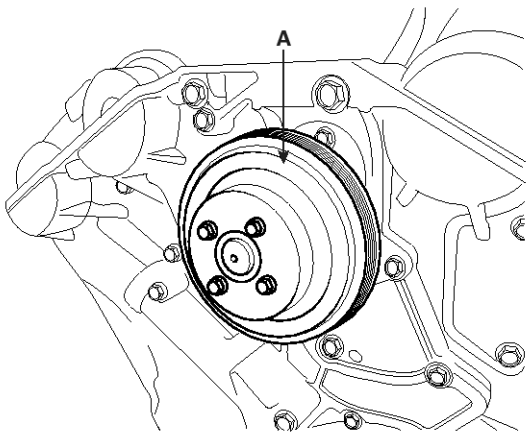

SBHEM8059D

21. Install the drive belt auto tensioner (A).

### Tightening torque

Bolt (B) :

81.4 ~ 85.3N.m (8.3 ~ 8.7kgf.m, 60.0 ~ 62.9lb-ft)

Bolt (C) :

17.7 ~ 21.6N.m (1.8 ~ 2.2kgf.m, 13.0 ~ 15.9lb-ft)

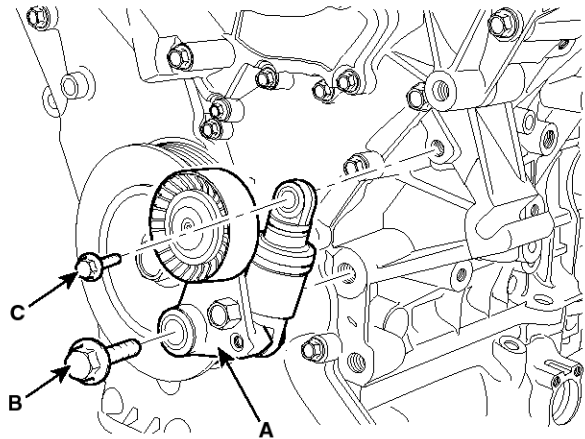

SENEM8020D

22. Install the drive belt idler (A).

### Tightening torque :

52.9 ~ 57.9N.m (5.4 ~ 5.9kgf.m, 39.1 ~ 42.7lb-ft)

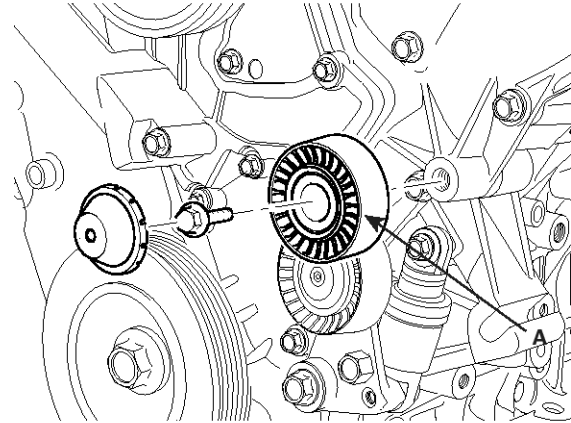

KDRF105A

# Timing System

23. Install the drive belt (A).

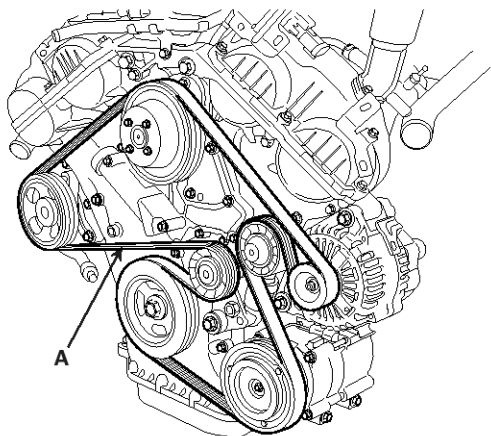

SBHEM8058D

24. Install the LH/RH cylinder head cover.

- 1) The hardening sealant located on the upper area between timing chain cover and cylinder head should be removed before assembling cylinder head cover.
- 2) After applying sealant (TB1217H), it should be assembled within 5 minutes.

**Bead width : 2.5mm (0.1in.)**

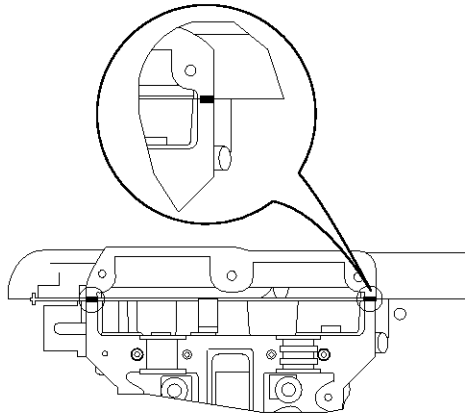

SBHEM8095D

- 3) The firing and/or blow out test should not be performed within 30 minutes after the cylinder head cover was assembled.
- 4) Install the cylinder head cover bolts as following method.

**Tightening torque :**

9.8 ~ 11.8N.m (1.0 ~ 1.2kgf.m, 7.2 ~ 8.7lb-ft)

## CAUTION

Do not reuse cylinder head cover gasket.

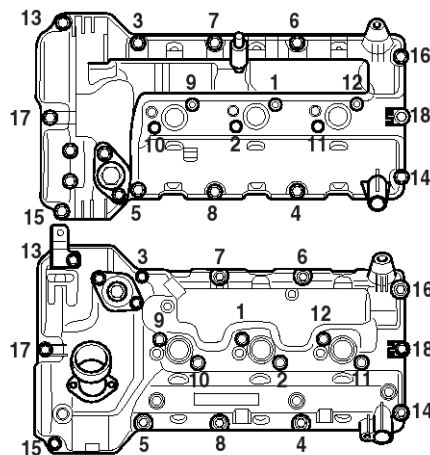

SBHEM8096D

25. Install the LH/RH ignition coils (A).

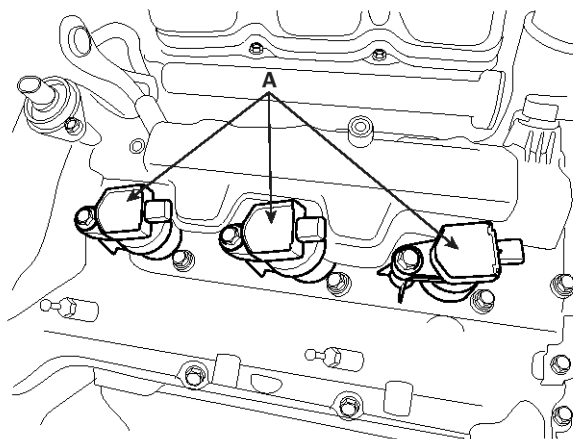

SBHEM8050D

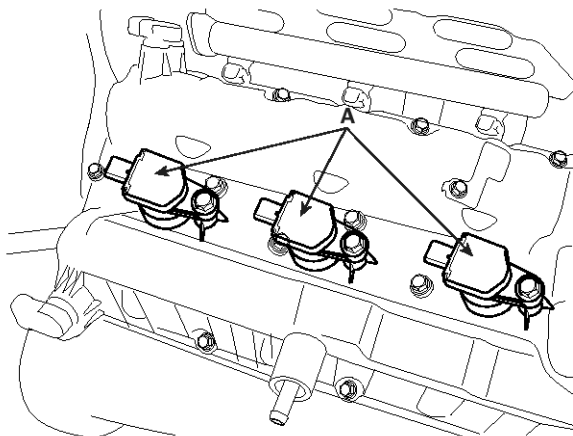

SBHEM8051D

## EM-50

## Engine Mechanical System

26. Connect the RH ignition coil connector (A) and the injector connector (B).

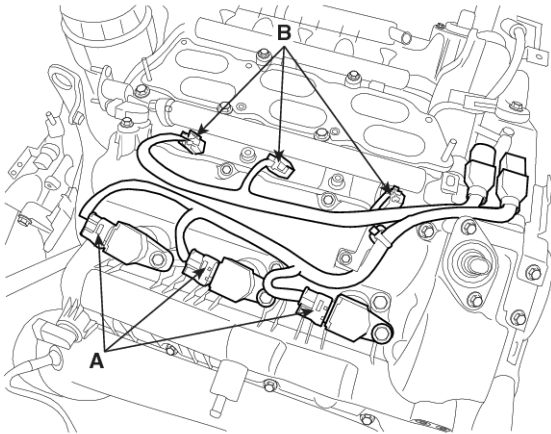

SBHEM8044D

27. Install the coolant pipe (A).

**Tightening torque :**

9.8 ~ 11.8N.m (1.0 ~ 1.2kgf.m, 7.2 ~ 8.7lb-ft)

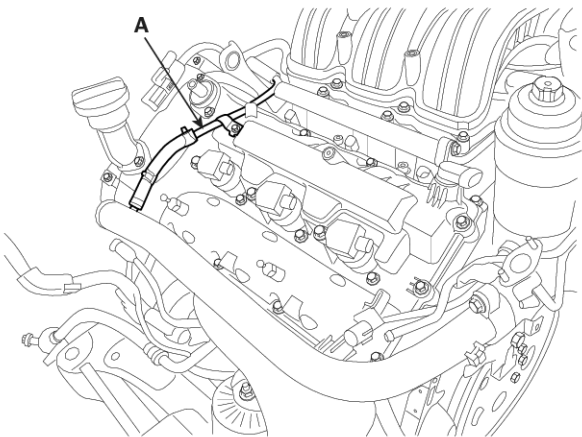

SHMEM9113L

28. Install the surge tank (A).

**Tightening torque :**

9.8 ~ 11.8N.m (1.0 ~ 1.2kgf.m, 7.2 ~ 8.7lb-ft)

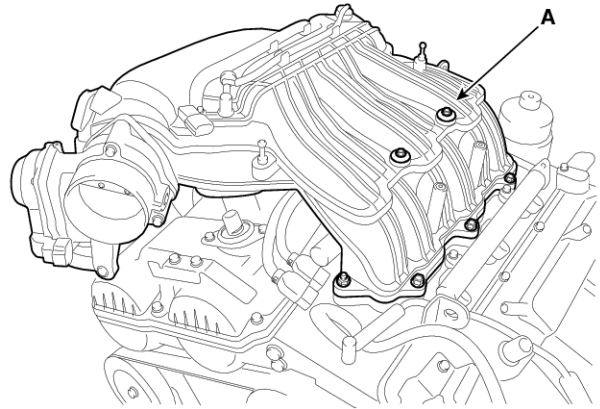

SHMEM9009L

29. Connect the throttle body coolant hoses (A), breather hose (B) and tighten the surge tank stay bolts (C).

**Tightening torque :**

27.5 ~ 31.4N.m (2.8 ~ 3.2kgf.m, 20.3 ~ 23.1lb-ft)

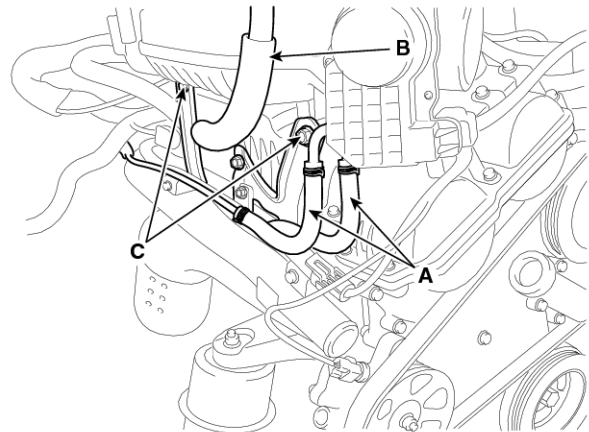

SHMEM9101L

## Timing System

## EM-51

30. Connect the engine wiring connectors.

- 1) Connect the water temperature sensor connector (A) and oil temperature sensor connector (B).

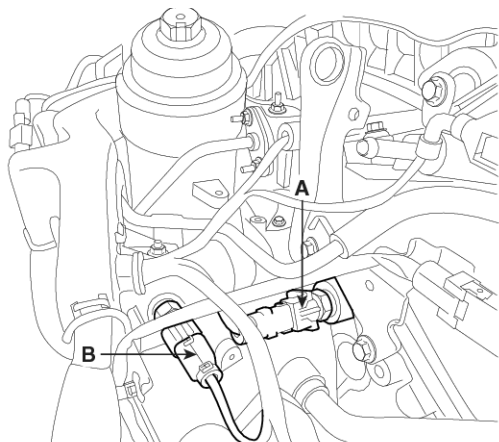

SBHEM8032D

- 2) Connect the VIS solenoid valve connector (A), PCSV connector (B), RH oxygen sensor connector (C) and the RH exhaust camshaft CMP sensor connector (D).

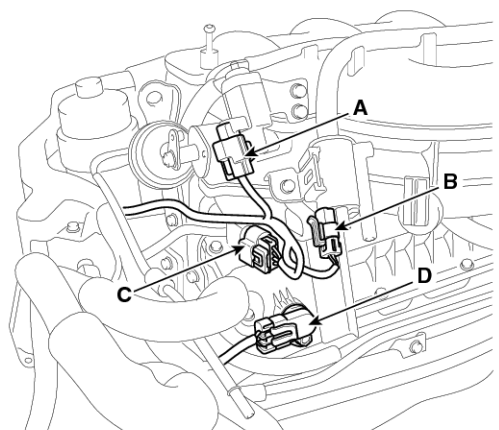

SHMEM9008L

- 3) Connect the LH intake camshaft CMP sensor connector (A), RH intake camshaft CMP sensor connector (B) and condenser connector (C).

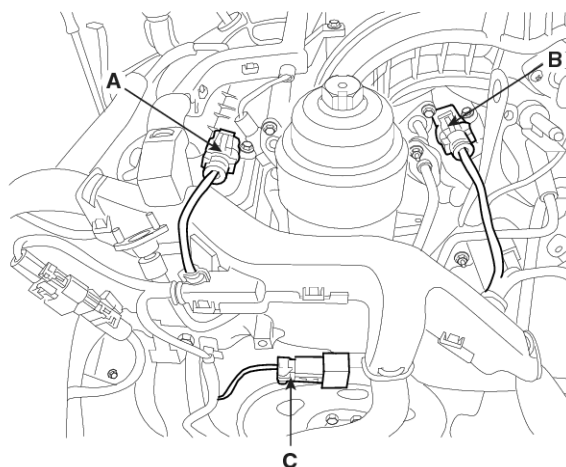

SBHEM8030D

- 4) Connect the oil pressure switch connector (A), LH exhaust camshaft CMP sensor connector (B) and LH oxygen sensor connector (C).

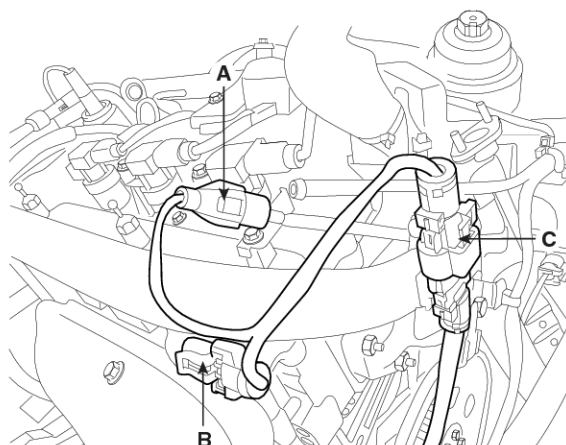

SBHEM8029D

## EM-52

## Engine Mechanical System

- 5) Connect the LH injector connector (A) and LH ignition coil connector (B).

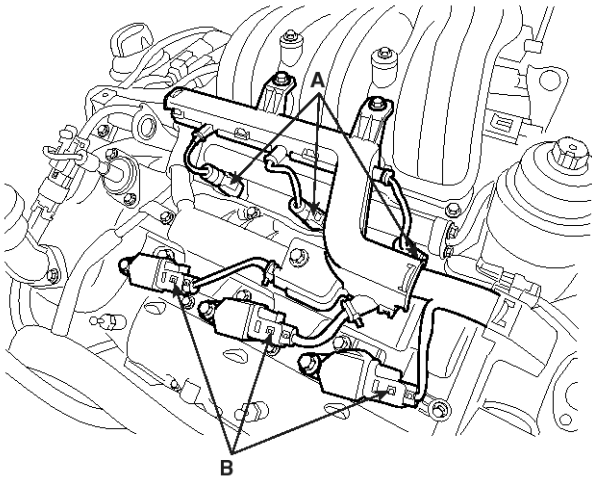

SBHEM8027D

- 6) Connect the LH knock sensor connector (A), LH/RH intake OCV connector (B) and LH exhaust OCV connector (C).

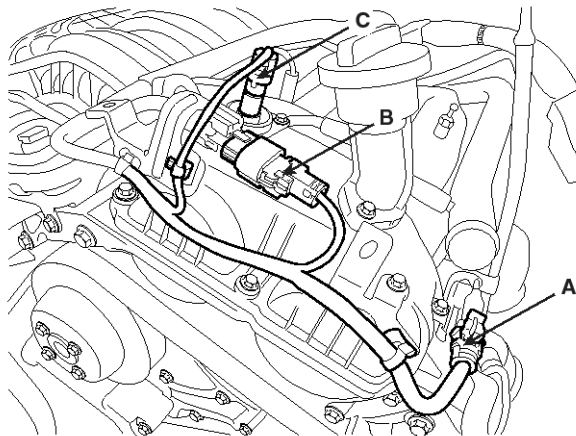

SBHEM8026D

- 7) Connect the MAP sensor connector (A), ETC connector (B), RH exhaust OCV connector (C), RH injector connector (D) and RH ignition coil connector (E).

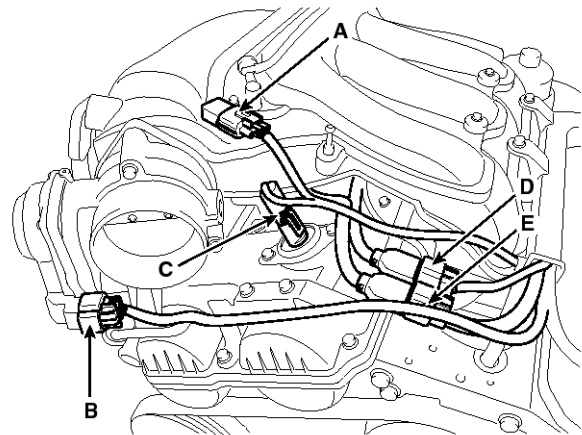

SHMEM9007L

- 8) Connect the power steering oil pressure switch connector (A) and RH knock sensor connector (B).

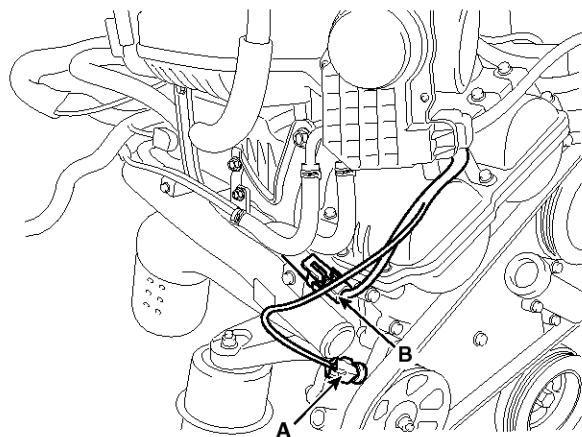

SHMEM9006L

## Timing System

## EM-53

31. Install the cooling fan assembly (B) and connect the fan connector (A).

Tightening torque :

8.8 ~ 13.7N.m (0.9 ~ 1.4kgf.m, 6.5 ~ 10.1lb-ft)

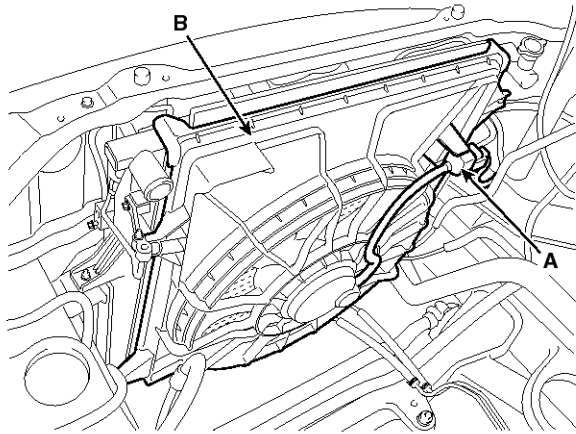

SHMEM9005L

32. Connect the purge control solenoid valve (PCSV) hose (A) and the brake booster vacuum hose (B).

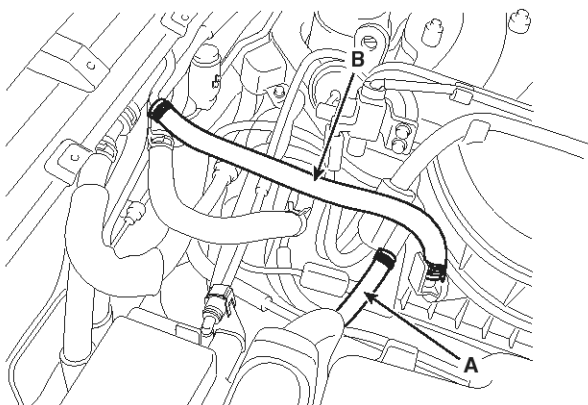

SHMEM9116L

33. Install the radiator upper hose (A) and lower hose (B).

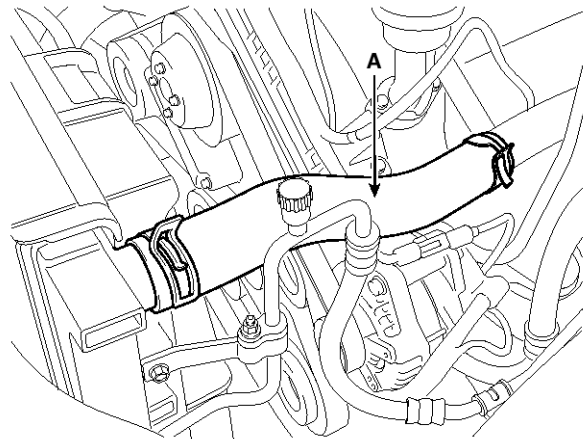

SHMEM9003L

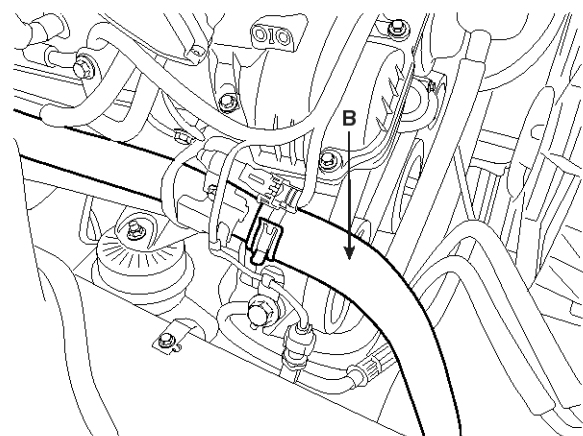

SBHEM8003D

## EM-54

## Engine Mechanical System

34. Install the air cleaner assembly (C), and connect the AFS connector (A), breather hose (B).

**Tightening torque :**

7.8 ~ 9.8N.m (0.8 ~ 1.0kgf.m, 5.8 ~ 7.2lb-ft)

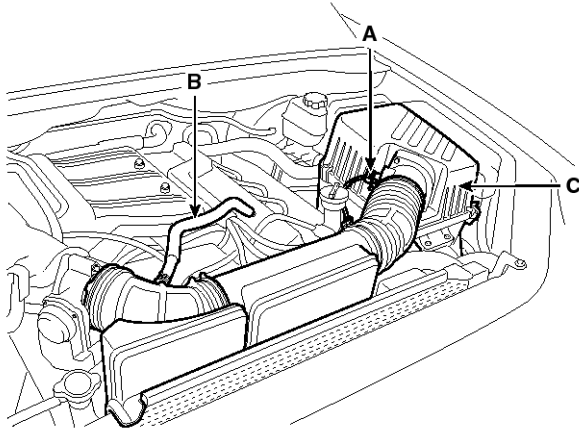

SHMEM9002L

35. Install the radiator grill upper guard (A).

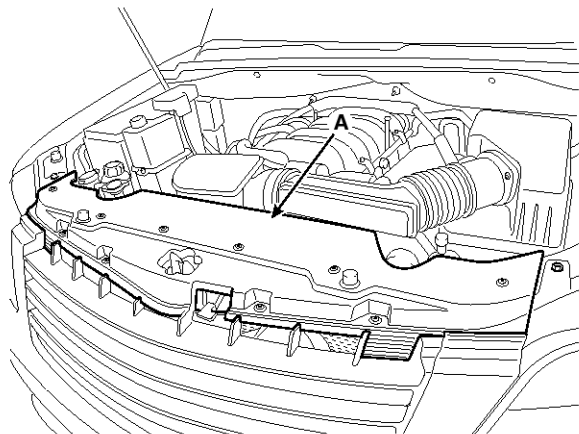

SHMM19045N

36. Install the engine cover (A).

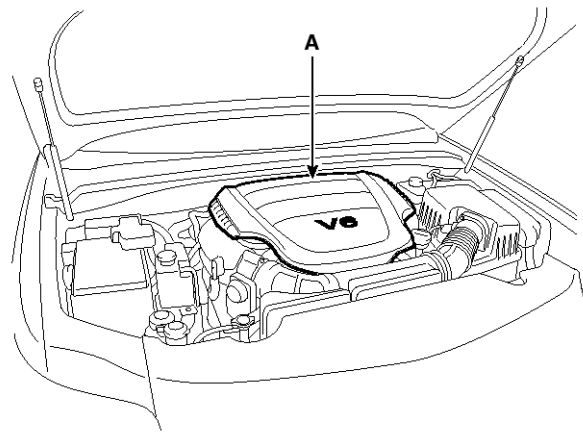

SHMEM9001L

37. Connect the battery negative cable(A).

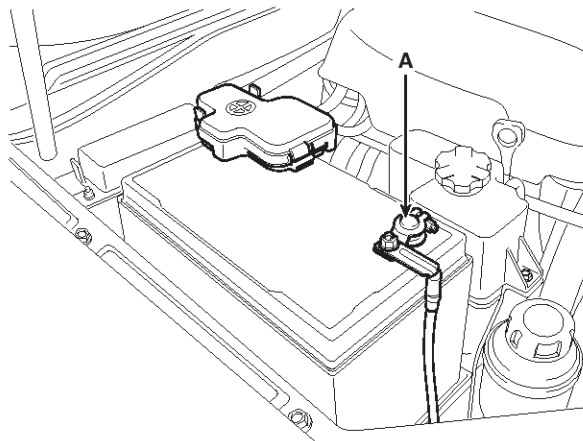

SHMM19043N

## NOTICE

- Refill engine oil.
- Clean the battery posts and cable terminals with sandpaper. Assemble and then apply grease to prevent corrosion.
- Inspect for fuel leakage.
  - After assembling the fuel line, turn on the ignition switch (do not operate the starter) so that the fuel pump runs for approximately two seconds and fuel line pressurizes.
  - Repeat this operation two or three times, and then check for fuel leakage at any point in the fuel lines.
- Refill radiator and reservoir tank with engine coolant.
- Bleed air from the cooling system.
  - Start engine and let it run until it warms up. (Until the radiator fan operates 3 or 4 times.)
  - Turn Off the engine. Check the level in the radiator, add coolant if needed. This will allow trapped air to be removed from the cooling system.
  - Put radiator cap on tightly, then run the engine again and check for leaks.

# EM-56

# Engine Mechanical System

## Cylinder Head Assembly

### Cylinder Head

#### Components

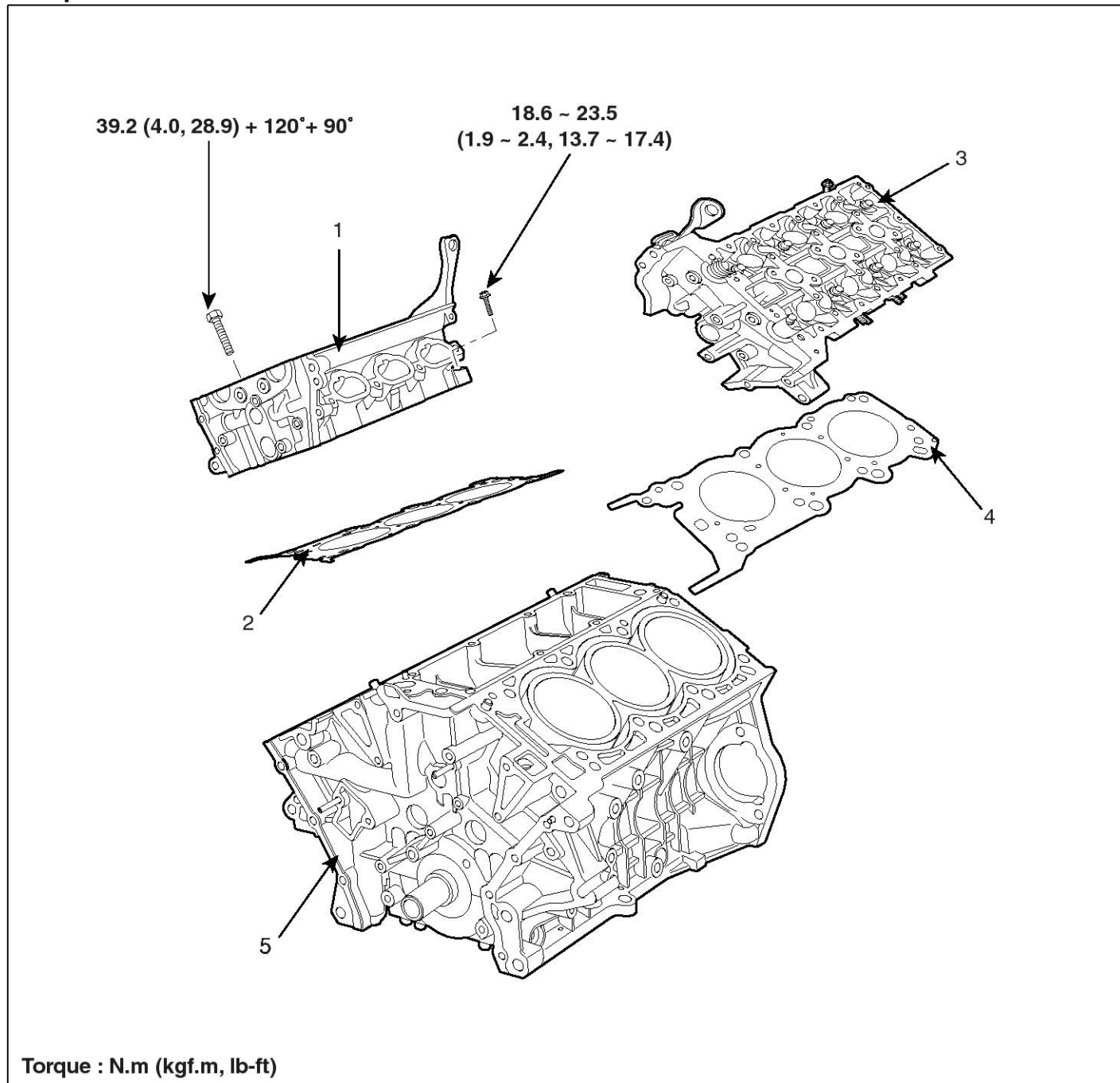

SBHEM9107L

- 1. RH Cylinder head
- 2. RH Cylinder head gasket
- 3. LH Cylinder head

- 4. LH Cylinder head gasket
- 5. Cylinder block

# Cylinder Head Assembly

EM-57

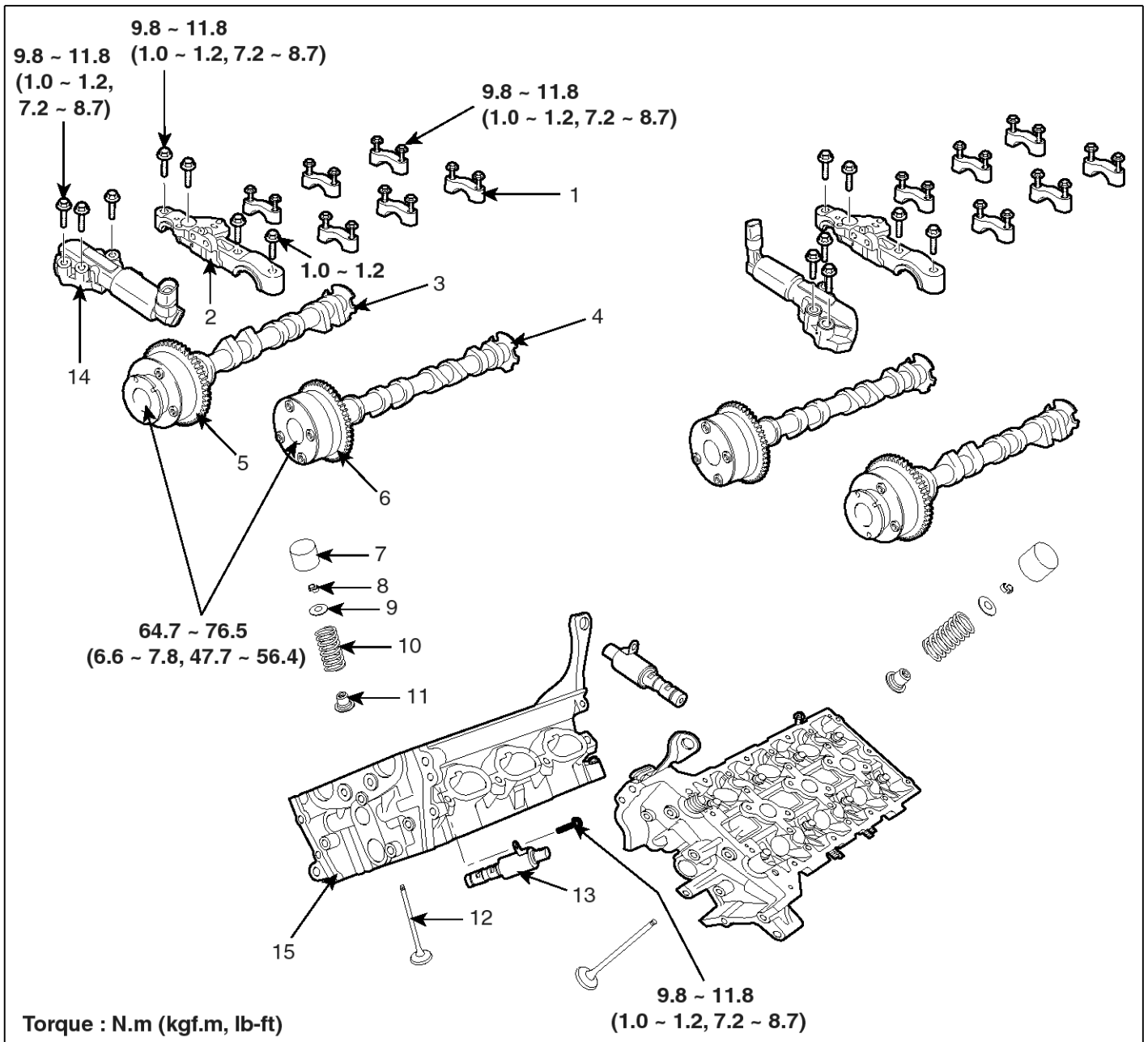

Torque : N.m (kgf.m, lb-ft)

9.8 - 11.8  
(1.0 - 1.2, 7.2 - 8.7)

SBHEM9077L

- |                                |                                   |                          |
|--------------------------------|-----------------------------------|--------------------------|
| 1. Camshaft bearing cap        | 6. Intake CVVT assembly           | 11. Valve stem seal      |
| 2. Camshaft thrust bearing cap | 7. Mechanical lash adjuster (MLA) | 12. Valve                |
| 3. Exhaust camshaft            | 8. Retainer lock                  | 13. Exhaust camshaft OCV |
| 4. Intake camshaft             | 9. Retainer                       | 14. Intake camshaft OCV  |
| 5. Exhaust CVVT assembly       | 10. Valve spring                  | 15. Cylinder head        |

## EM-58

## Engine Mechanical System

### Removal

#### ⚠ CAUTION

- Use fender covers to avoid damaging painted surfaces.
- To avoid damaging the cylinder head, wait until the engine coolant temperature drops below normal temperature (20°C [68°F]) before removing it.
- When handling a metal gasket, take care not to fold the gasket or damage the contact surface of the gasket.
- To avoid damage, unplug the wiring connectors carefully while holding the connector portion.

#### 📌 NOTICE

- Mark all wiring and hoses to avoid misconnection.
  - Turn the crankshaft pulley so that the No. 1 piston is at top dead center.
1. Remove the timing chain. (Refer to Timing system in this group)

2. Remove the mounting bolts (B, C) and then remove the water temperature control assembly (A).

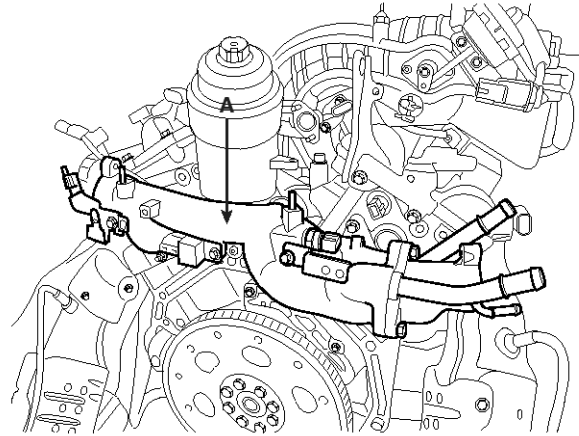

SBHEM8041D

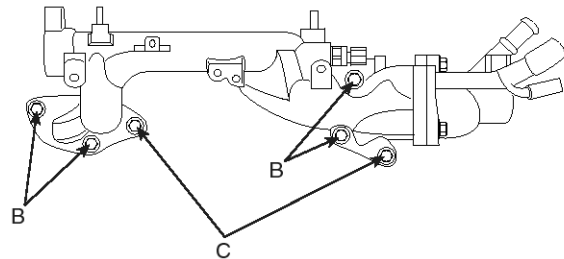

SBHEM8042D

# Cylinder Head Assembly

EM-59

3. Disconnect the water vent hose (A) and then remove the intake the manifold (B).

**CAUTION**

- Be sure to drain the engine coolant before removing the intake manifold.
- If any coolant drained from the cylinder head vent hole has entered the intake port ; this can potentially lead to engine trouble.

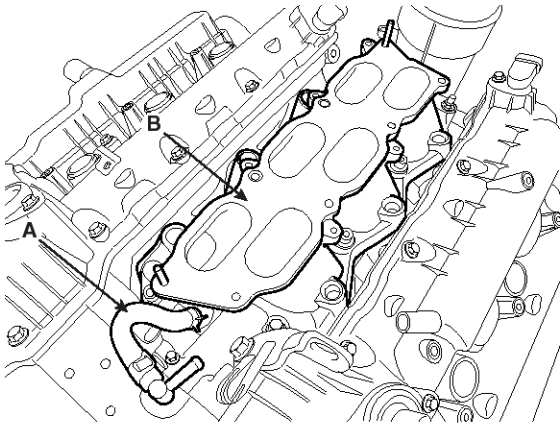

SBHEM8148D

4. Remove the LH/RH exhaust manifold heat protector (A).

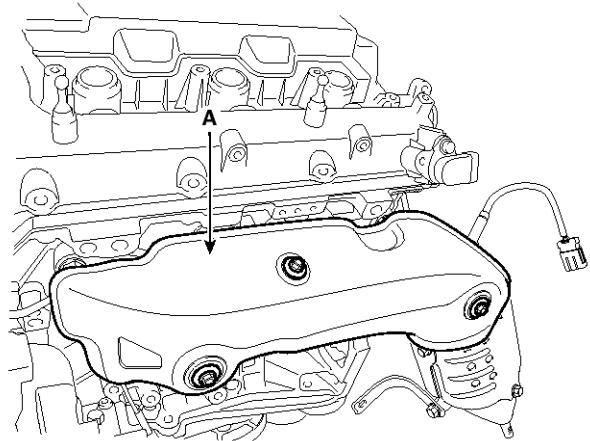

SHMEM9019L

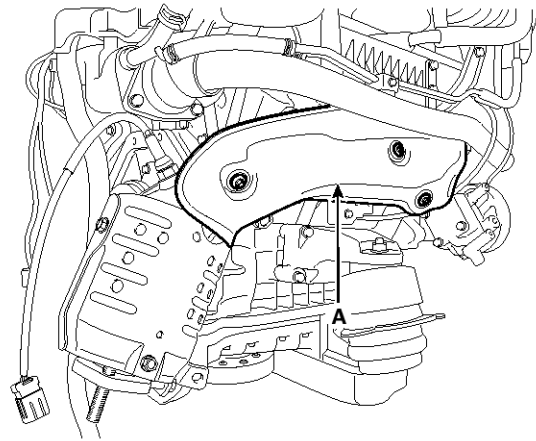

SHMEM9017L

## EM-60

## Engine Mechanical System

5. Loosen the LH/RH exhaust manifold stay bolt (A).

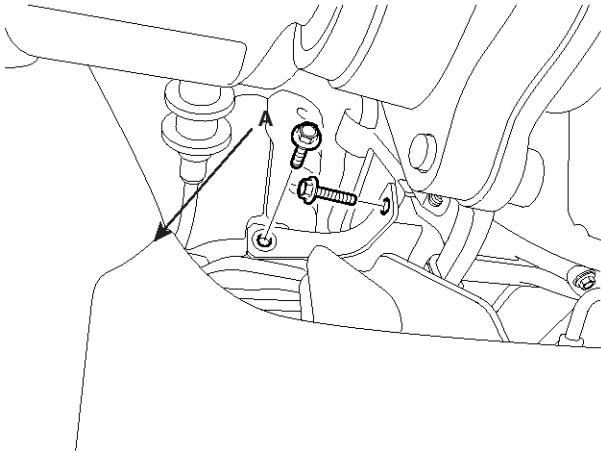

SHMEM9104L

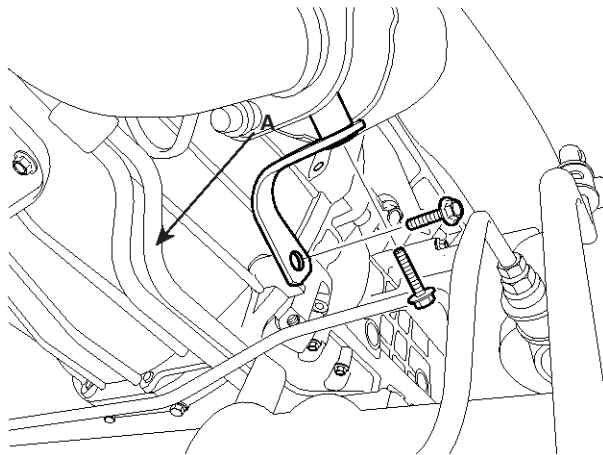

SHMEM9105L

6. Remove the LH/RH exhaust manifold (A).

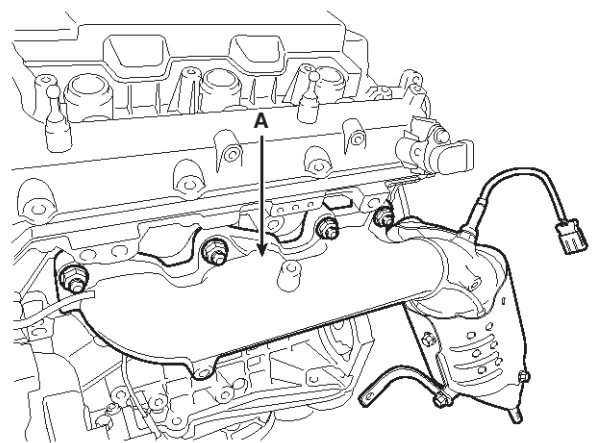

SHMEM9020L

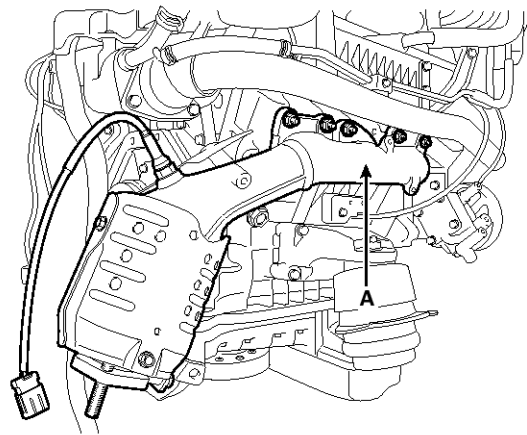

SHMEM9018L

# Cylinder Head Assembly

EM-61

7. Remove the LH/RH exhaust camshaft OCV (A).

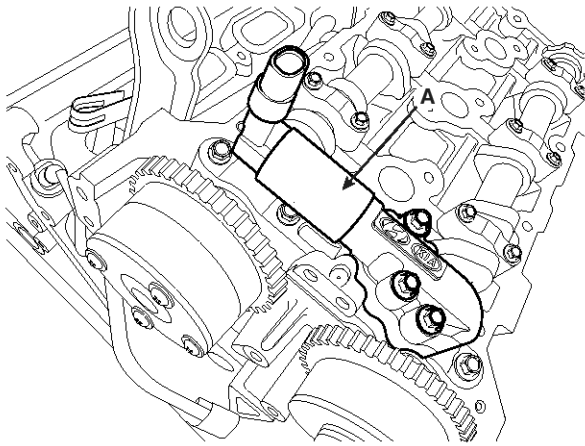

SBHEM8068D

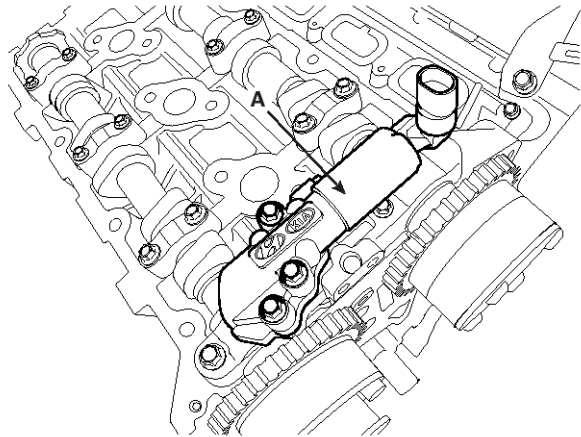

SBHEM8069D

8. Remove the LH/RH camshaft bearing cap (A) and thrust bearing cap (B).

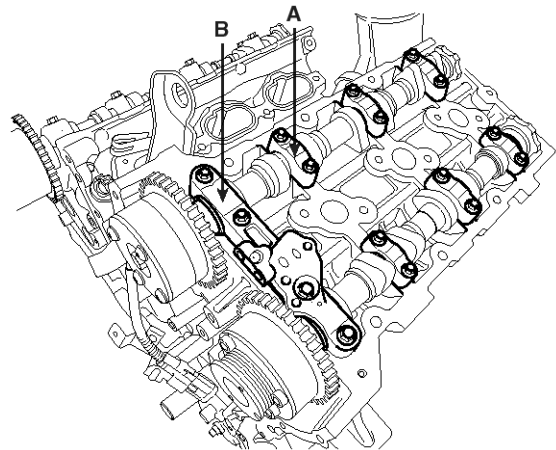

SBHEM8070D

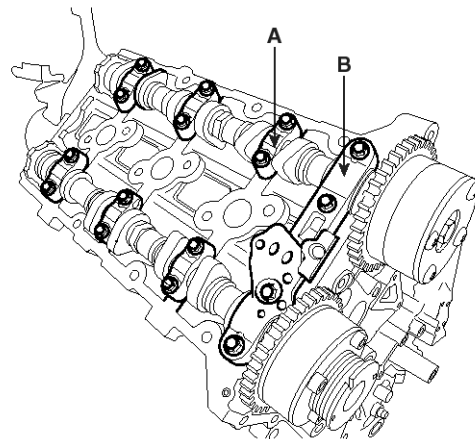

SBHEM8071D

## EM-62

## Engine Mechanical System

9. Remove the LH/RH camshaft assembly (A).

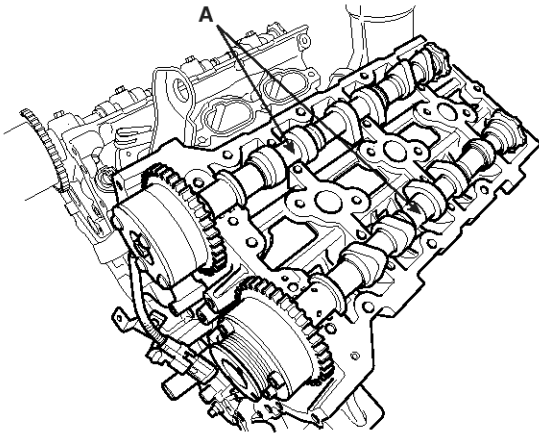

SBHEM8072D

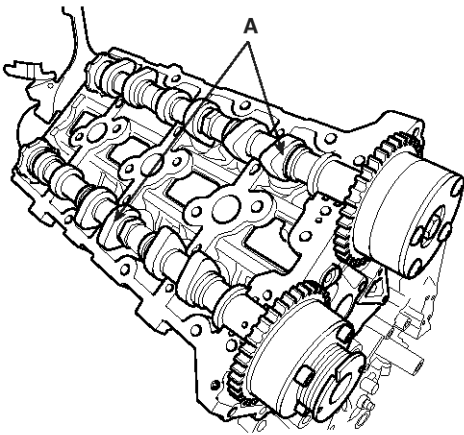

SBHEM8073D

10. Remove the cylinder head.

1) Uniformly loosen and remove the cylinder head bolts, in several passes, in the sequence shown.

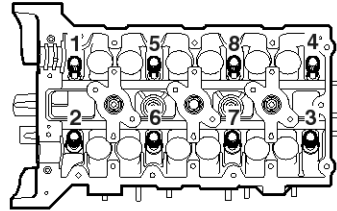
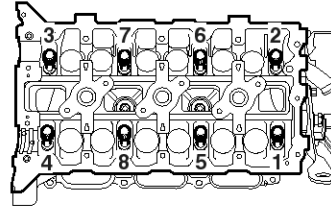

KDRF199A

### **CAUTION**

Head warpage or cracking could result from removing bolts in an incorrect order.

2) Lift the cylinder head from the dowels on the cylinder block and place the cylinder head on wooden blocks on a bench.

### **CAUTION**

Be careful not to damage the contact surfaces of the cylinder head and cylinder block.

# Cylinder Head Assembly

EM-63

## Disassembly

### NOTICE

Identify MLA, valves and valve springs as they are removed so that each item can be reinstalled in its original position.

1. Remove the MLAs(A).

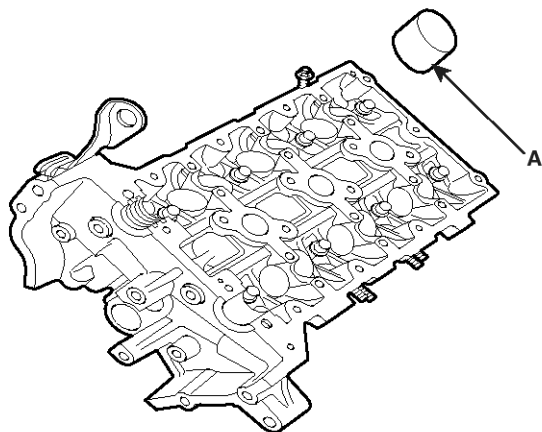

KDRF200A

2. Remove the valves.

- 1) Using the SST(09222-3K000, 09222-3C300), compress the valve spring and remove retainer lock.

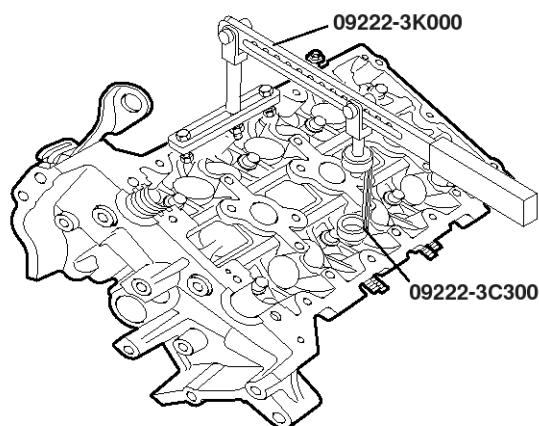

KDRF201A

- 2) Remove the spring retainer.
- 3) Remove the valve spring.
- 4) Remove the valve.
- 5) Using the SST(09222-29000), remove the valve stem seal.

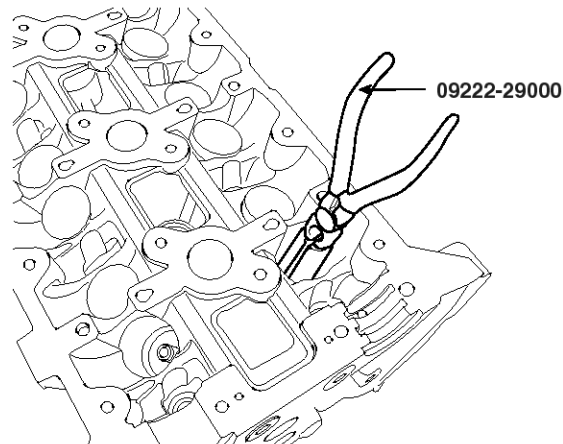

KDRF234A

### NOTICE

Do not reuse old valve stem seals.

3. Remove the OCV(A).

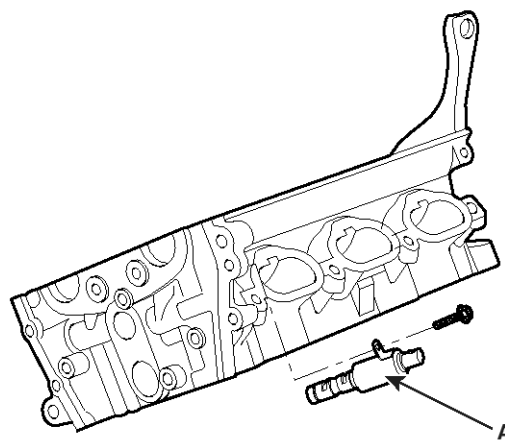

KDRF202A

## EM-64

## Engine Mechanical System

### Inspection

#### Cylinder Head

1. Inspect for flatness.

Using a precision straight edge and feeler gauge, measure the surface contacting cylinder block and the manifolds for warpage.

#### Flatness of cylinder head gasket surface

Standard : Less than 0.05mm(0.002in.)

[Less than 0.02mm(0.0008in.)/150x150]

#### Flatness of manifold gasket surface

Standard : Less than 0.03mm(0.001in)/110x110

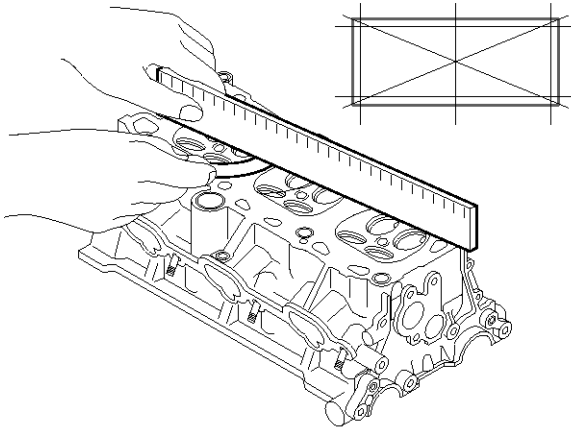

EDQF160A

2. Inspect for cracks.

Check the combustion chamber, intake ports, exhaust ports and cylinder block surface for cracks. If cracked, replace the cylinder head.

### Valve And Valve Spring

1. Inspect valve stems and valve guides.

- 1) Using a caliper gauge, measure the inside diameter of the valve guide.

#### Valve guide I.D.

Intake / Exhaust : 5.500 ~ 5.512mm (0.216 ~ 0.217in.)

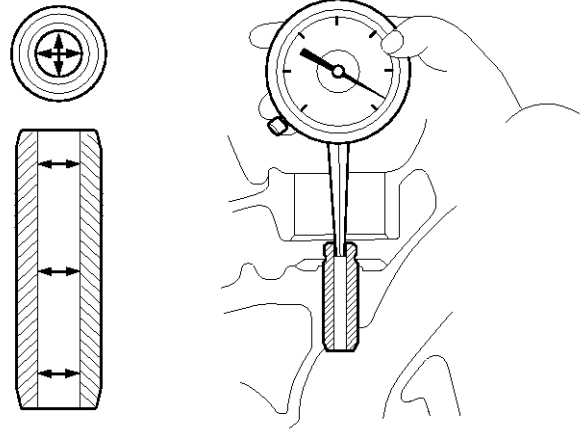

ECBF034A

- 2) Using a micrometer, measure the diameter of the valve stem.

#### Valve stem O.D.

Intake : 5.465 ~ 5.480mm (0.2151 ~ 0.2157in.)

Exhaust : 5.458 ~ 5.470mm (0.2149 ~ 0.2153in.)

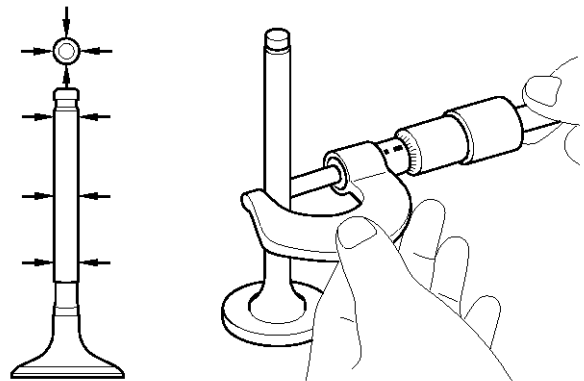

KCRF227A

# Cylinder Head Assembly

EM-65

- 3) Subtract the valve stem diameter measurement from the valve guide inside diameter measurement.

## Valve stem-to-guide clearance

[Standard]

Intake : 0.020 ~ 0.047mm (0.0008 ~ 0.0018in.)

Exhaust : 0.030 ~ 0.054mm (0.0012 ~ 0.0021in.)

[Limit]

Intake : 0.07mm (0.0027in.)

Exhaust : 0.09mm (0.0035in.)

## 2. Inspect valves.

- 1) Check the valve is ground to the correct valve face angle.
- 2) Check that the surface of the valve for wear.  
If the valve face is worn, replace the valve.
- 3) Check the valve head margin thickness.  
If the margin thickness is less than minimum, replace the valve.

## Margin

[Standard]

Intake : 1.56 ~ 1.86mm (0.06142 ~ 0.07323in.)

Exhaust : 1.73 ~ 2.03mm (0.06811 ~ 0.07992in.)

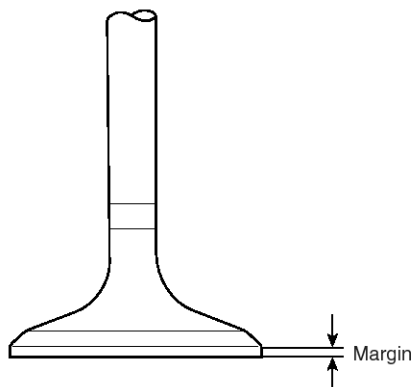

ECKD221A

- 4) Check the valve length.

## Length

Intake : 105.27mm (4.1445in)

Exhaust : 105.50mm (4.1535in)

- 5) Check the surface of the valve stem tip for wear.  
If the valve stem tip is worn, replace the valve.

## 3. Inspect valve seats

Check the valve seat for evidence of overheating and improper contact with the valve face.

If the valve seat is worn, replace cylinder head.

Before reconditioning the seat, check the valve guide for wear. If the valve guide is worn, replace cylinder head. Recondition the valve seat with a valve seat grinder or cutter. The valve seat contact width should be within specifications and centered on the valve face.

## 4. Inspect valve springs.

- 1) Using a steel square, measure the out-of-square of the valve spring.
- 2) Using vernier calipers, measure the free length of the valve spring.

## Valve spring

[Standard]

Free height : 43.86mm (1.7267in.)

Out-of-square : 1.5°

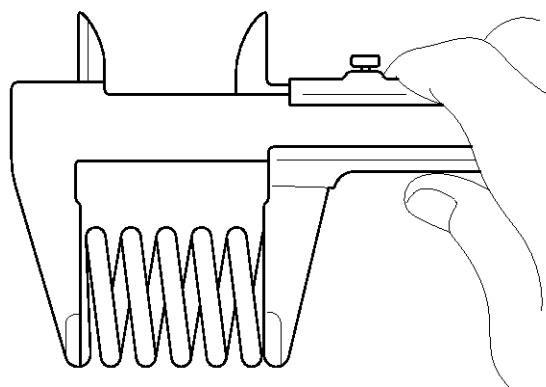

KCRF205A

## EM-66

## Engine Mechanical System

### MLA

1. Inspect MLAs.

Using a micrometer, measure the MLA outside diameter.

### MLA O.D.

Intake/Exhaust :

34.964 ~ 34.980mm(1.3765 ~ 1.3771in.)

2. Using a caliper gauge, measure MLA tappet bore inner diameter of cylinder head.

### Tappet bore I.D.

Intake/Exhaust :

35.000 ~ 35.025mm(1.3779 ~ 1.3789in.)

3. Subtract MLA outside diameter measurement from tappet bore inside diameter measurement.

### MLA to tappet bore clearance

[Standard]

Intake/Exhaust : 0.020 ~ 0.061mm(0.0008 ~ 0.0024in.)

[Limit]

Intake/Exhaust : 0.07mm(0.0027in.)

### Camshaft

1. Inspect cam lobes.

Using a micrometer, measure the cam lobe height.

### Cam height

[Standard value]

Intake : 46.8mm (1.8425in.)

Exhaust : 45.8mm (1.8031in.)

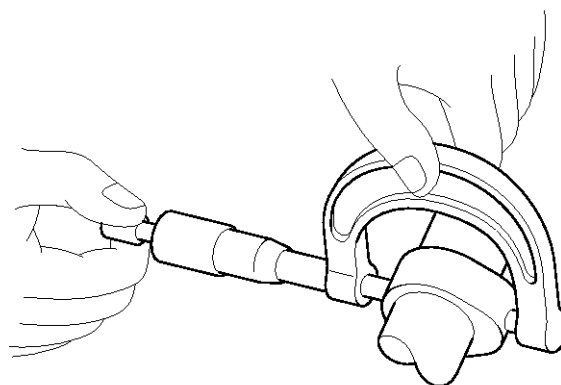

KCRF206A

If the cam lobe height is less than standard, replace the camshaft.

2. Inspect the camshaft journal clearance.
  - 1) Clean the bearing caps and camshaft journals.
  - 2) Place the camshafts on the cylinder head.
  - 3) Lay a strip of plastigage across each of the camshaft journals.

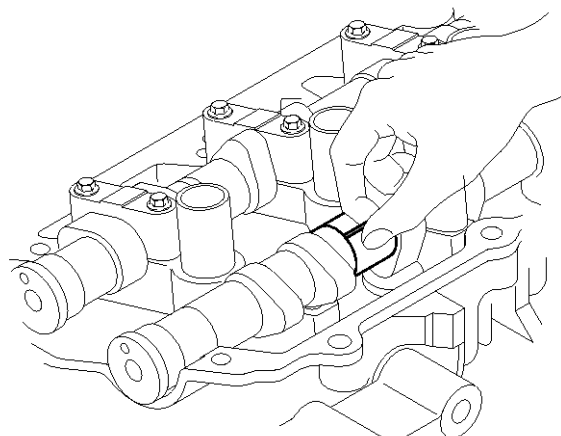

KCRF207A

# Cylinder Head Assembly

EM-67

- 4) Install the bearing cap (A) and thrust bearing cap (B) with specified torque.

### Tightening torque :

1st step : 5.8N.m (0.6kgf.m, 4.3lb-ft)

2nd step : 9.8 ~ 11.8N.m (1.0 ~ 1.2kgf.m, 7.2 ~ 8.7lb-ft)

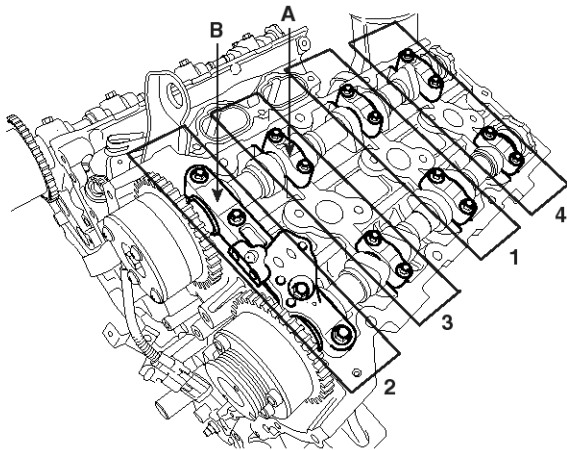

SBHEM8133D

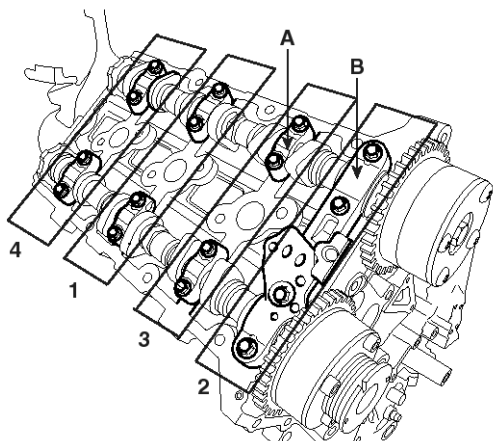

SBHEM8134D

### ⚠ CAUTION

**Do not turn the camshaft.**

- 5) Remove the bearing caps.
- 6) Measure the plastigage at its widest point.

### Bearing oil clearance

[Standard value]

Intake

No.1 journal : 0.020 ~ 0.057mm (0.0008 ~ 0.0022in.)

No.2,3,4 journal : 0.030 ~ 0.067mm (0.0012 ~ 0.0026in.)

Exhaust

No.1 journal : 0.027 ~ 0.057mm (0.0010 ~ 0.0022in.)

No.2,3,4 journal : 0.030 ~ 0.067mm (0.0012 ~ 0.0026in.)

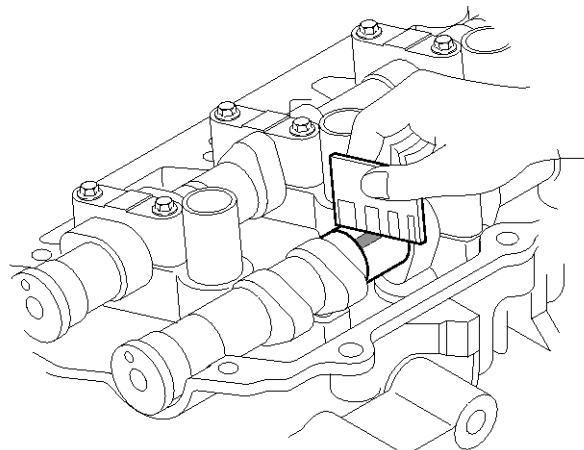

KCRF208A

If the oil clearance is greater than maximum, replace the camshaft. If necessary, replace cylinder head.

- 7) Completely remove the plastigage.
  - 8) Remove the camshafts.
3. Inspect the camshaft end play.
    - 1) Install the camshafts.
    - 2) Using a dial indicator, measure the end play while moving the camshaft back and forth.

### Camshaft end play

[Standard value] : 0.02 ~ 0.18mm(0.0008 ~ 0.0071in.)

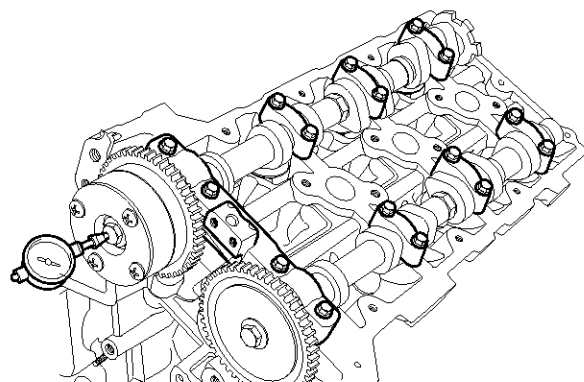

KDRF196B

If the end play is greater than maximum, replace the camshaft. If necessary, replace cylinder head.

- 3) Remove the camshafts.

## EM-68

## Engine Mechanical System

### CVVT Assembly

1. Inspect the CVVT assembly.

- 1) Check that the CVVT assembly will not turn.
- 2) Apply vinyl tape to the retard hole except the one indicated by the arrow in the illustration.

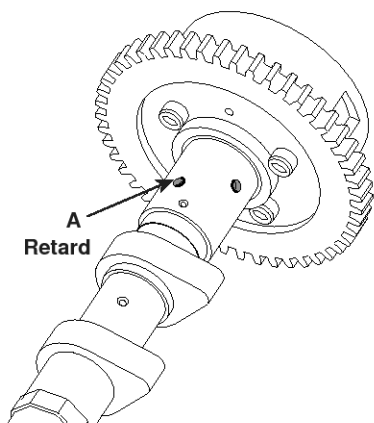

ECRF015A

- 3) Wrap tape around the tip of the air gun and apply air of approx. 150kpa(1.5kgf/cm<sup>2</sup>, 21psi) to the port of the camshaft.

(Perform this in order to release the lock pin for the maximum delay angle locking.)

#### NOTICE

When the oil splashes, wipe it off with a shop rag.

- 4) Under the condition of (3), turn the CVVT assembly to the advance angle side (the arrow marked direction in the illustration) with your hand.

Depending on the air pressure, the CVVT assembly will turn to the advance side without applying force by hand.

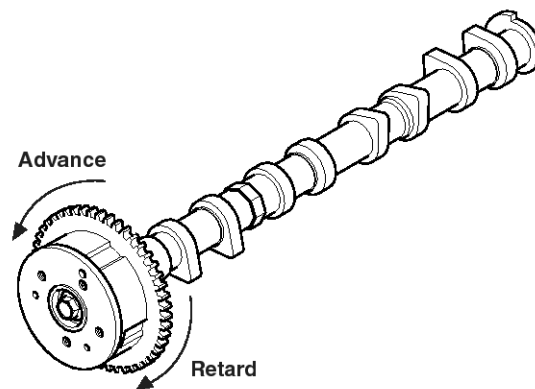

SGHEM7010N

- 5) Except the position where the lock pin meets at the maximum delay angle, let the CVVT assembly turn back and forth and check the movable range and that there is no interference.

---

**Standard:** Movable smoothly in the range about 30°

---

- 6) Turn the CVVT assembly with your hand and lock it at the maximum delay angle position (clockwise).

# Cylinder Head Assembly

EM-69

## Reassembly

### NOTICE

Thoroughly clean all parts to be assembled.

Before installing the parts, apply fresh engine oil to all sliding and rotating surfaces.

Replace oil seals with new ones.

### 1. Install the valves.

- 1) Using the SST(09222-3C100), push in a new oil seal.

### NOTICE

Do not reuse old valve stem seals.

Incorrect installation of the seal could result in oil leakage past the valve guides.

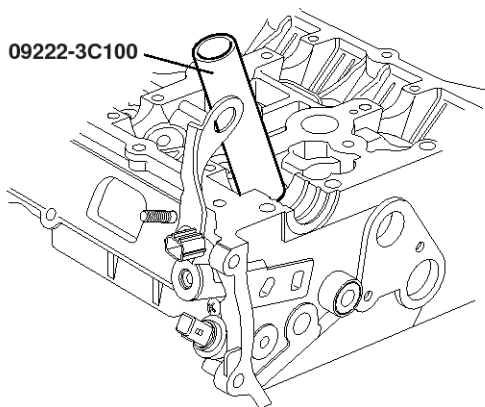

KCRF120B

- 2) Install the valve, valve spring and spring retainer.

### NOTICE

Place valve springs so that the side coated with enamel faces toward the valve spring retainer and then install the retainer.

- 3) Using the SST(09222 - 3K000, 09222-3C300), compress the spring and install the retainer locks. After installing the valves, ensure that the retainer locks are correctly in place before releasing the valve spring compressor.

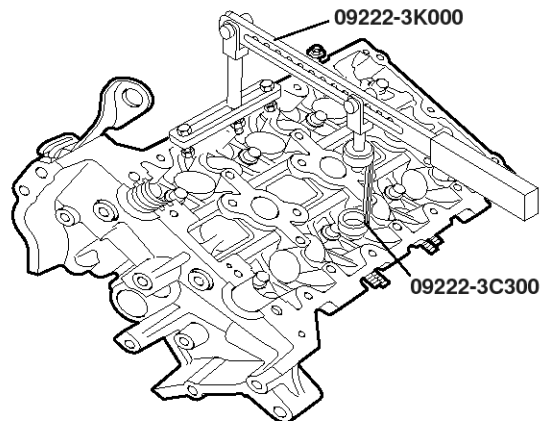

KDRF201A

- 4) Lightly tap the end of each valve stem two or three times with the wooden handle of a hammer to ensure proper seating of the valve and retainer lock.

### 2. Install the MLAs.

Check that the MLA rotates smoothly by hand.

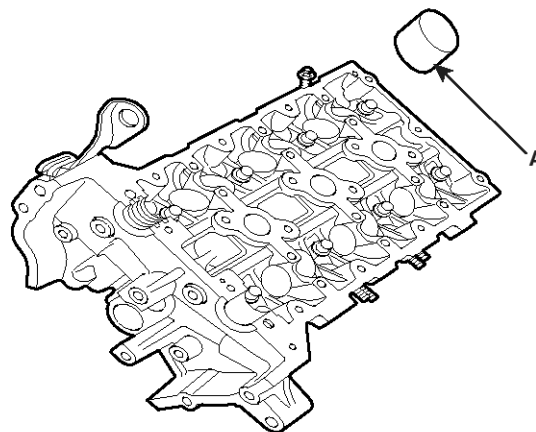

KDRF200A

### NOTICE

MLA can be reinstalled in its original position.

## EM-70

## Engine Mechanical System

3. Install the OCV(A).

### Tightening torque

9.80 ~ 11.76Nm(1.0 ~ 1.2kgf.m, 7.23 ~ 8.68lb-ft)

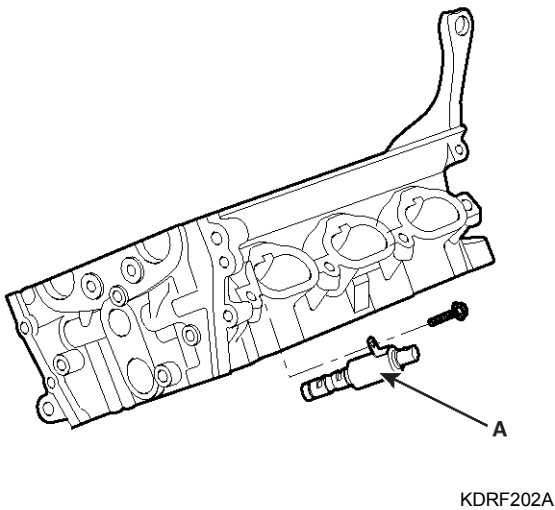

### NOTICE

- Install OCV with gray colored connector into RH bank.
- Install OCV with black colored connector into LH bank.

### CAUTION

- Do not reuse the OCV when dropped.
- Keep the OCV clean.
- Do not hold the OCV sleeve during servicing.
- When the OCV is installed on the engine, do not move the engine while holding the OCV yoke.

### Installation

#### NOTICE

- Thoroughly clean all parts to be assembled.
- Always use a new head and manifold gasket.
- The cylinder head gasket is a metal gasket. Take care not to bend it.
- Rotate the crankshaft, set the No.1 piston at TDC.

1. Install the cylinder head.

- The sealant locations on cylinder head and cylinder block must be free of engine oil and ETC.
- Apply sealant on cylinder block top face before assembling cylinder head gaskets.

The part must be assembled within 5 minutes after sealant was applied.

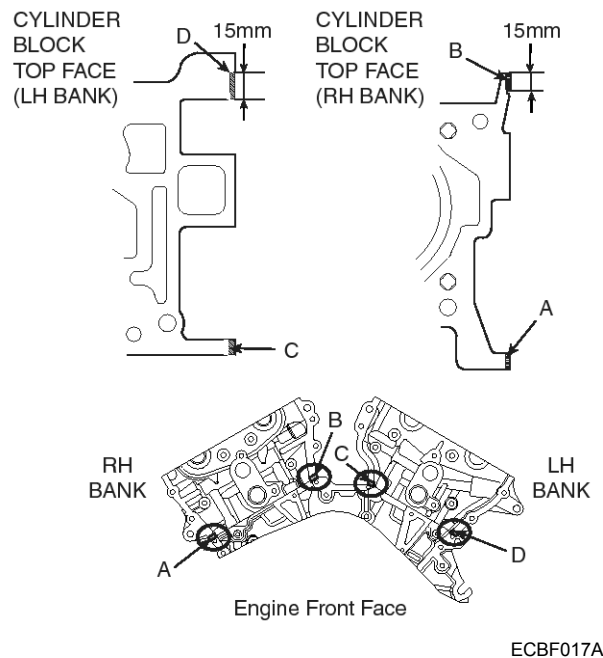

# Cylinder Head Assembly

EM-71

## NOTICE

Refer to below illustration to apply the sealant.

### Bead width :

2.0~3.0 mm (0.078 ~ 0.118 in.)

### Sealant locations :

1.0~1.5mm (0.039 ~ 0.059 in.) from block surface

Recommended sealant : Liquid sealant TB1217H

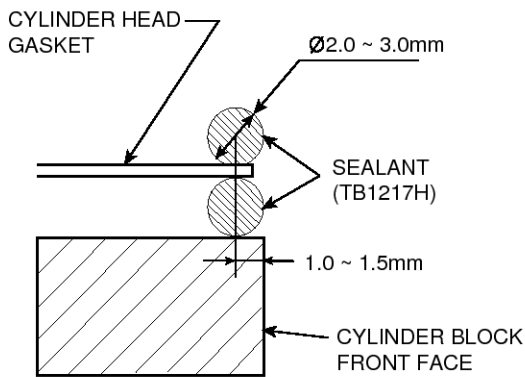

ECBF018A

- c. Apply sealant on cylinder head gaskets after assembling cylinder head gaskets on cylinder block.

The part must be assembled within 5 minutes after sealant was applied.

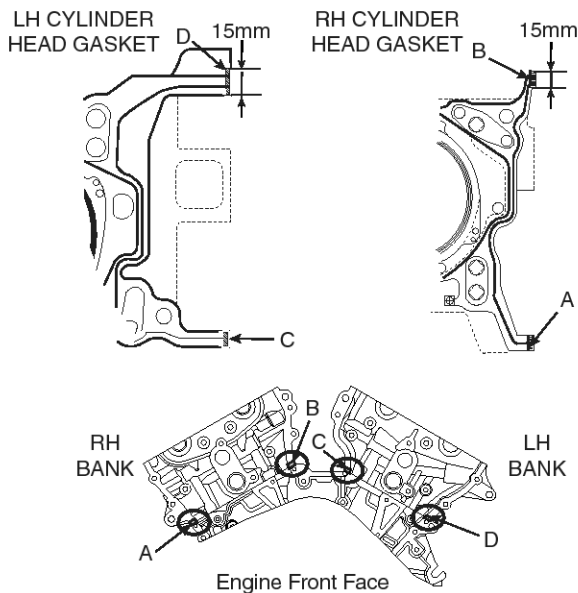

ECBF019A

## NOTICE

Be careful of the installation direction.

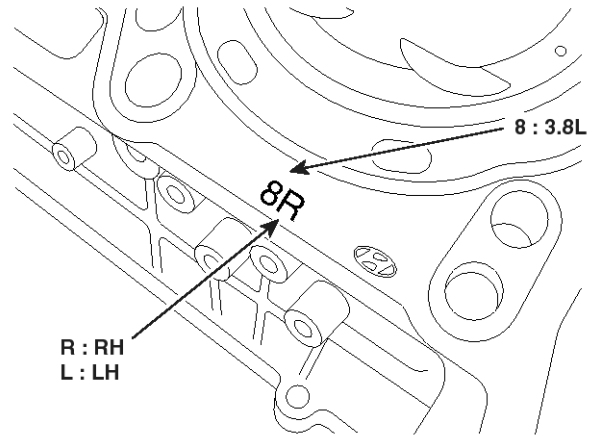

SHMEM9114L

- d. Install the cylinder head.

## NOTICE

Remove the extruded sealant after assembling cylinder heads.

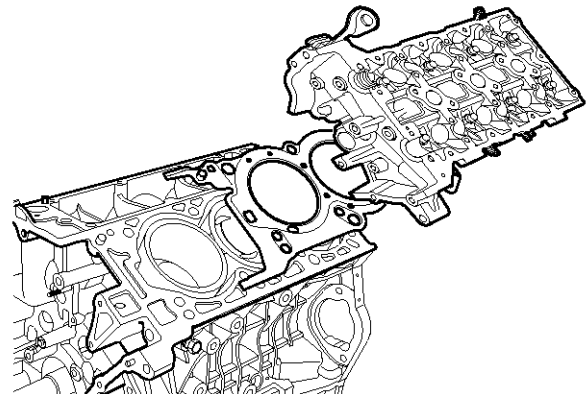

KDRF198A

## EM-72

## Engine Mechanical System

2. Install cylinder head bolts.

- 1) Do not apply engine oil on the threads and under the heads of the cylinder head bolts.
- 2) Using SST(09221-4A000), install and tighten the cylinder head bolts and plate washers, in several passes, in the sequence shown.

### Tightening torque

Head bolt: 39.2N.m (4.0kgf.m, 28.9lb-ft)+ 120° + 90°

Bolt (A):18.6 ~ 23.5Nm (1.9 ~ 2.4kgf.m, 13.7 ~ 17.4lb-ft)

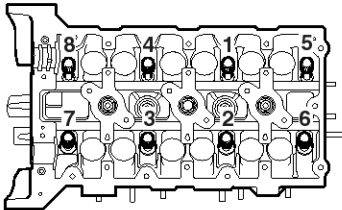
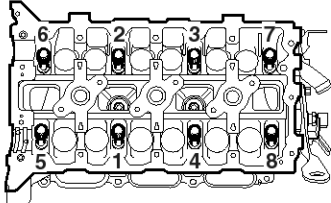

KDRF199B

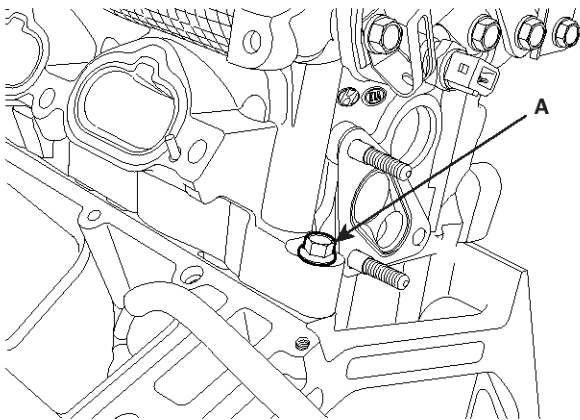

ECBF035A

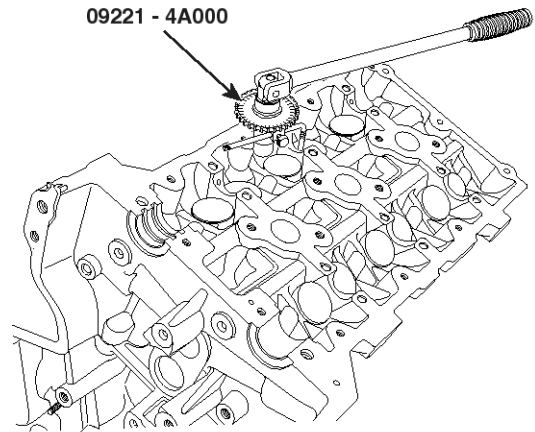

KDRF223A

3. Install the CVVT assembly.

### Tightening torque :

64.7 ~ 76.5N.m (6.6 ~ 7.8kgf.m, 47.7 ~ 56.4lb-ft)

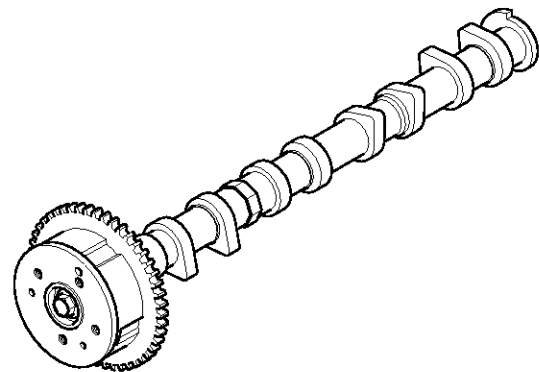

KCRF122A

### ⚠ CAUTION

- Install camshaft-inlet to dowel pin of CVVT assembly.  
At this time, attend not to be installed to oil hole of camshaft-inlet.
- Hold the hexagonal head wrench portion of the camshaft with a vise, and install the bolt and CVVT assembly.
- Do not rotate CVVT assembly when camshaft is installed to dowel pin of CVVT assembly.

# Cylinder Head Assembly

EM-73

4. Install the LH/RH camshaft assembly (A).

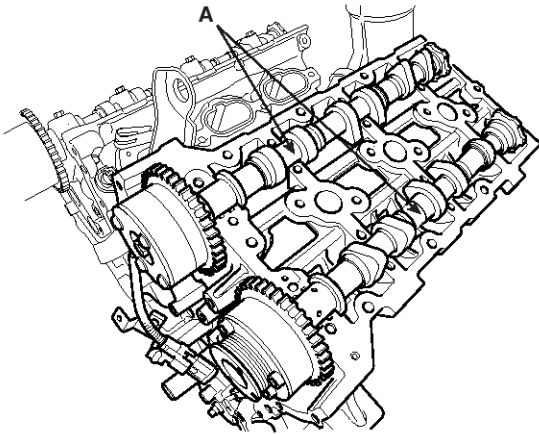

SBHEM8072D

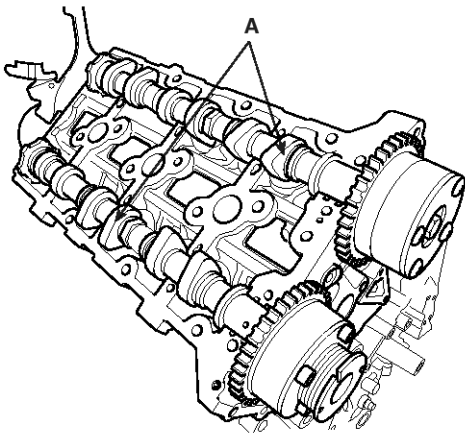

SBHEM8073D

**CAUTION**

- Apply a light coat of engine oil on camshaft journals.
- Assemble the key groove of camshaft rear side to the same level of head top surface.
- Be careful the right, left bank, intake, exhaust side before assembling.

## Intake Camshaft

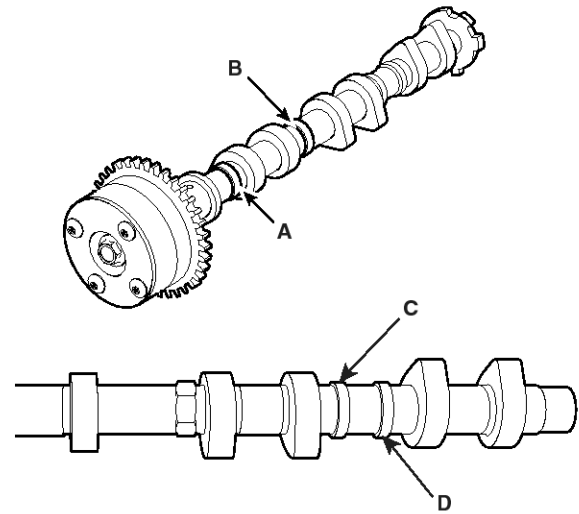

SENEM8006D

As for camshaft identification, refer to the table below.

Displacement	Outer diameter	
	LH	RH
3.8L Intake camshaft	A : 27mm (1.0630in.)	A : 27mm (1.0630in.)
	B : 30mm (1.1811in.)	B : 30mm (1.1811in.)
	C : 30mm (1.1811in.)	C : 27mm (1.0630in.)
	D : 27mm (1.0630in.)	D : 30mm(1.1811in.)

# EM-74

# Engine Mechanical System

## Exhaust Camshaft

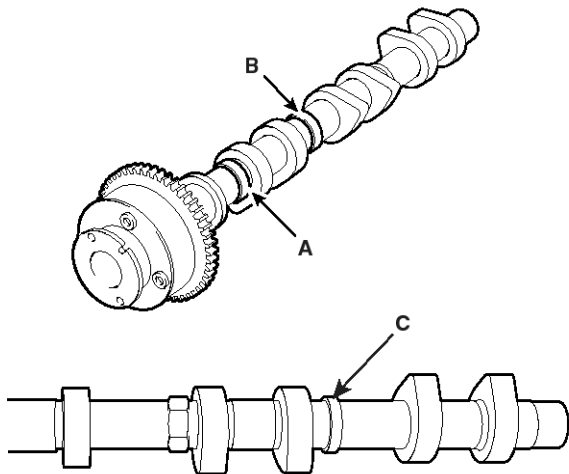

SBHEM8109D

As for camshaft identification, refer to the table below.

Displacement	Outer diameter	
	LH	RH
3.8L Exhaust camshaft	A : 27mm (1.0630in.)	A : 27mm (1.0630in.)
	B : 30mm (1.1811in.)	B : 30mm (1.1811in.)
	C : 27mm (1.0630in.)	C : 30mm (1.1811in.)

5. Install the LH/RH camshaft bearing cap (A) and thrust bearing cap (B).

### Tightening torque

1st step : 5.8N.m (0.6kgf.m, 4.3lb-ft)

2nd step : 9.8 ~ 11.8N.m (1.0 ~ 1.2kgf.m, 7.2 ~ 8.7lb-ft)

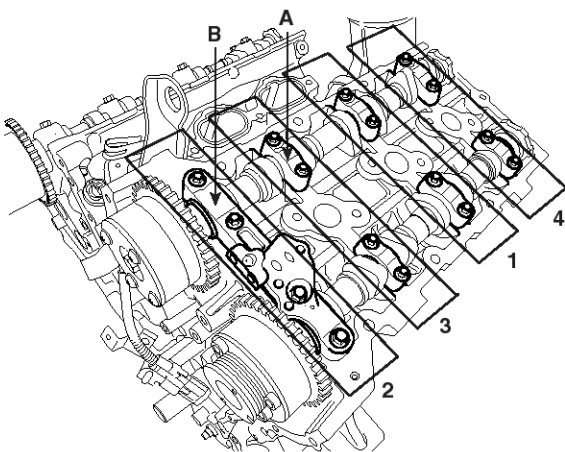

SBHEM8133D

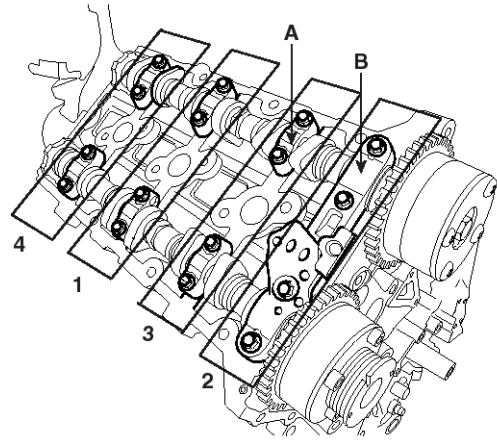

SBHEM8134D

### CAUTION

Be sure to install the thrust bearing cap bolts and the bearing cap bolts in the correct place.

### NOTICE

Be careful the right, left bank, intake, exhaust side before assembling.

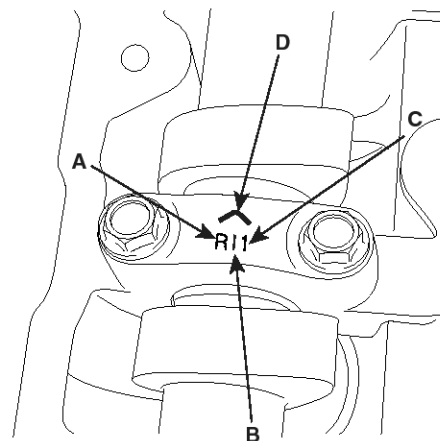

ECBF036A

A : L(LH),R(RH)

B : I(Intake), None(Exhaust)

C : Journal number

D : Front mark

### CAUTION

Rotate the crankshaft not to contact the valves to the pistons by making the pistons below 10mm(0.3937in.) from the top of cylinder block.

# Cylinder Head Assembly

# EM-75

6. Install the LH/RH exhaust camshaft OCV (A).

**Tightening torque :**

9.8 ~ 11.8N.m (1.0 ~ 1.2kgf.m, 7.2 ~ 8.7lb-ft)

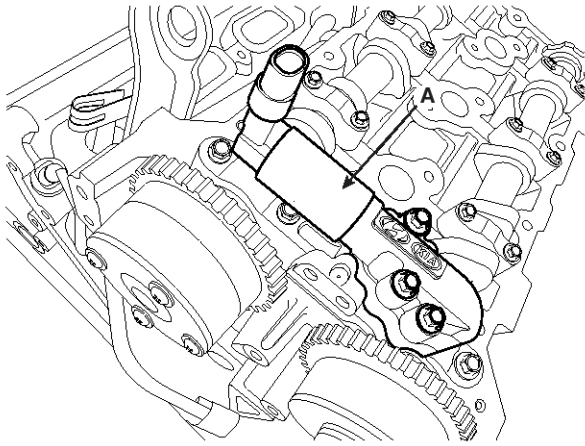

SBHEM8068D

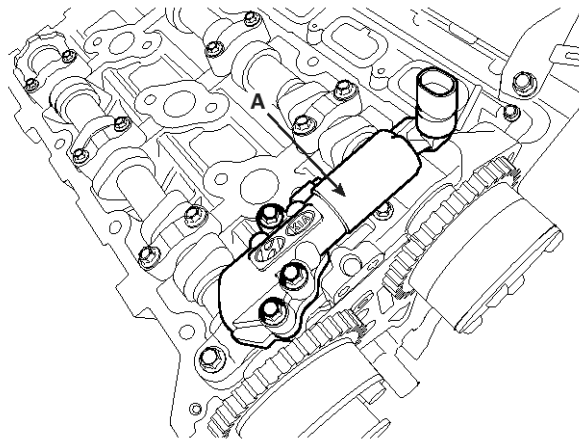

SBHEM8069D

7. Install the LH/RH exhaust manifold (A) with a new gasket.

**Tightening torque :**

39.2 ~ 44.1N.m (4.0 ~ 4.5kgf.m, 28.9 ~ 32.5lb-ft)

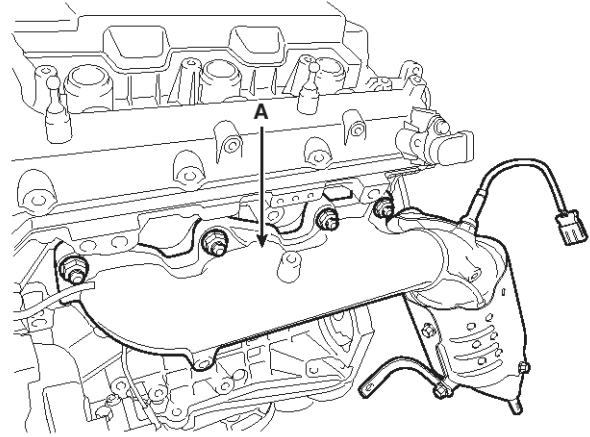

SHMEM9020L

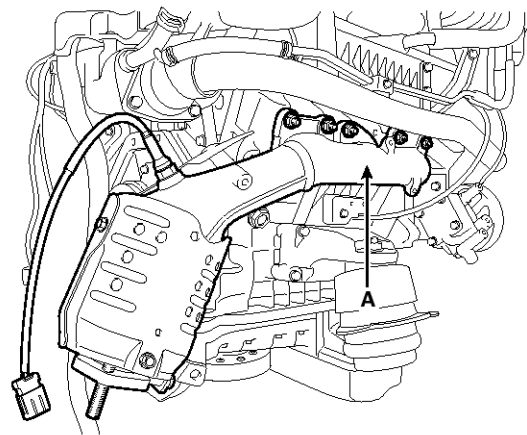

SHMEM9018L

## EM-76

## Engine Mechanical System

8. Install the LH/RH exhaust manifold heat protector (A).

**Tightening torque :**

9.8 ~ 11.8N.m (1.0 ~ 1.2kgf.m, 7.2 ~ 8.7lb-ft)

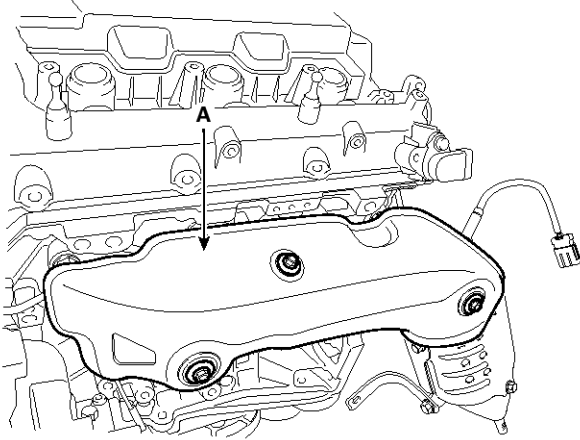

SHMEM9019L

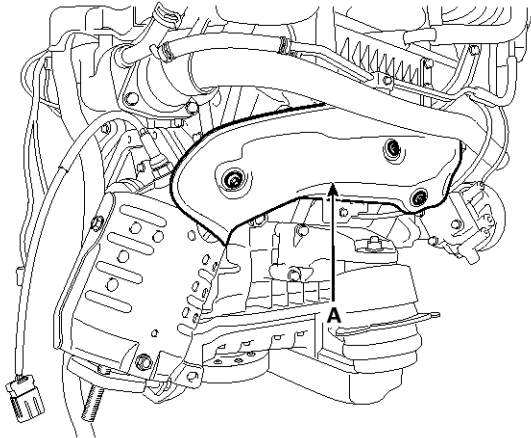

SHMEM9017L

9. Install the LH/RH exhaust manifold stay bolt (A).

**Tightening torque :**

34.3 ~ 41.2N.m (3.5 ~ 4.2kgf.m, 25.3 ~ 30.4lb-ft)

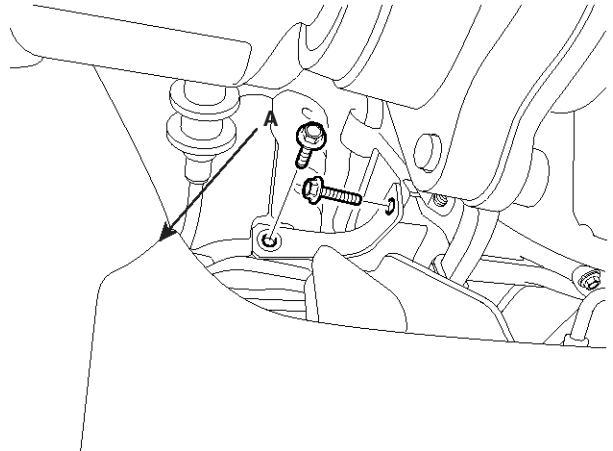

SHMEM9104L

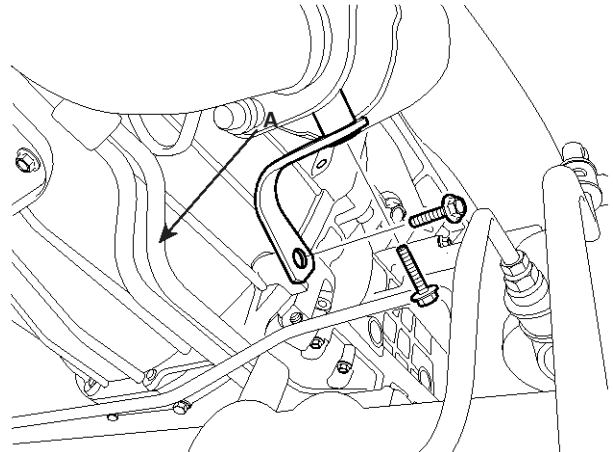

SHMEM9105L

# Cylinder Head Assembly

EM-77

10. Install the intake manifold (B) with a new gasket, and connect the water vent hose (A).

**CAUTION**

- Be sure to drain the engine coolant before removing the intake manifold.
- If any coolant drained from the cylinder head vent hole has entered the intake port ; this can potentially lead to engine trouble.

**Tightening torque**

Step 1: 3.9 ~ 5.9N.m (0.4 ~ 0.6kgf.m, 2.9 ~ 4.3lb-ft)

Step 2:

Nut-18.62 ~ 23.52N.m (1.9~2.4kgf.m, 13.74~17.36lb-ft)

Bolt -26.5 ~ 31.4 N.m (2.7 ~ 3.2 kgf.m, 19.5 ~ 23.1lb-ft)

Step 3: Repeat 2nd step twice or more.

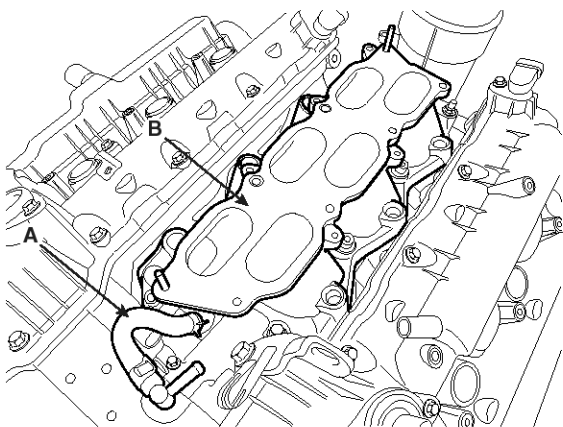

SBHEM8148D

a - h : 1st step order

1 ~ 8 : 2nd step order

**NOTICE**

Confirm the manifold gasket identification mark (LH, RH) and be careful of the installation direction.

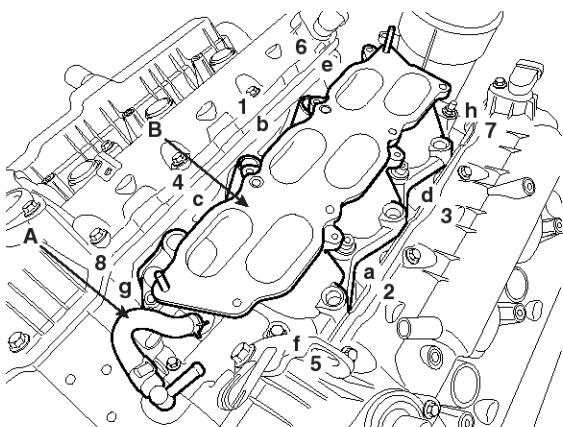

SBHEM8045D

11. Install the water temperature control assembly (A) with a new gasket.

**Tightening torque :**

19.6 ~ 23.5Nm (2.0 ~ 2.4kgf.m, 14.5 ~ 17.4lb-ft)

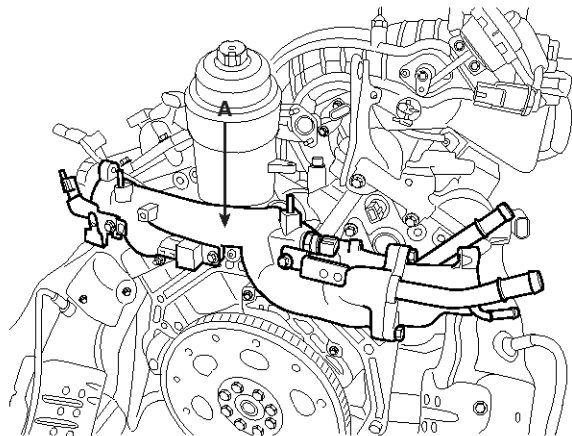

SBHEM8041D

**CAUTION**

When tightening the bolt (C), use a ground bolt.

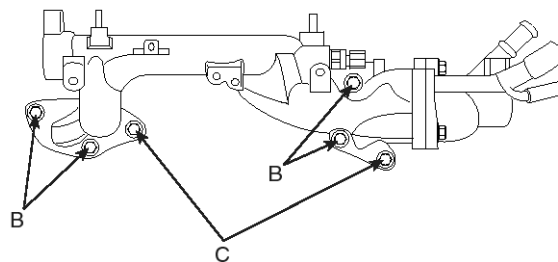

SBHEM8042D

12. Install the timing chain. (Refer to Timing system in this group)

**NOTICE**

- Refill engine oil.
- Clean the battery posts and cable terminals with sandpaper. Assemble and then apply grease to prevent corrosion.
- Inspect for fuel leakage.
  - After assembling the fuel line, turn on the ignition switch (do not operate the starter) so that the fuel pump runs for approximately two seconds and fuel line pressurizes.
  - Repeat this operation two or three times, then check for fuel leakage at any point in the fuel lines.
- Refill radiator and reservoir tank with engine coolant.
- Bleed air from the cooling system.
  - Start engine and let it run until it warms up. (Until the radiator fan operates 3 or 4 times.)
  - Turn Off the engine. Check the level in the radiator, add coolant if needed. This will allow trapped air to be removed from the cooling system.
  - Put radiator cap on tightly, then run the engine again and check for leaks.

# Cylinder Block

EM-79

## Cylinder Block

### Components

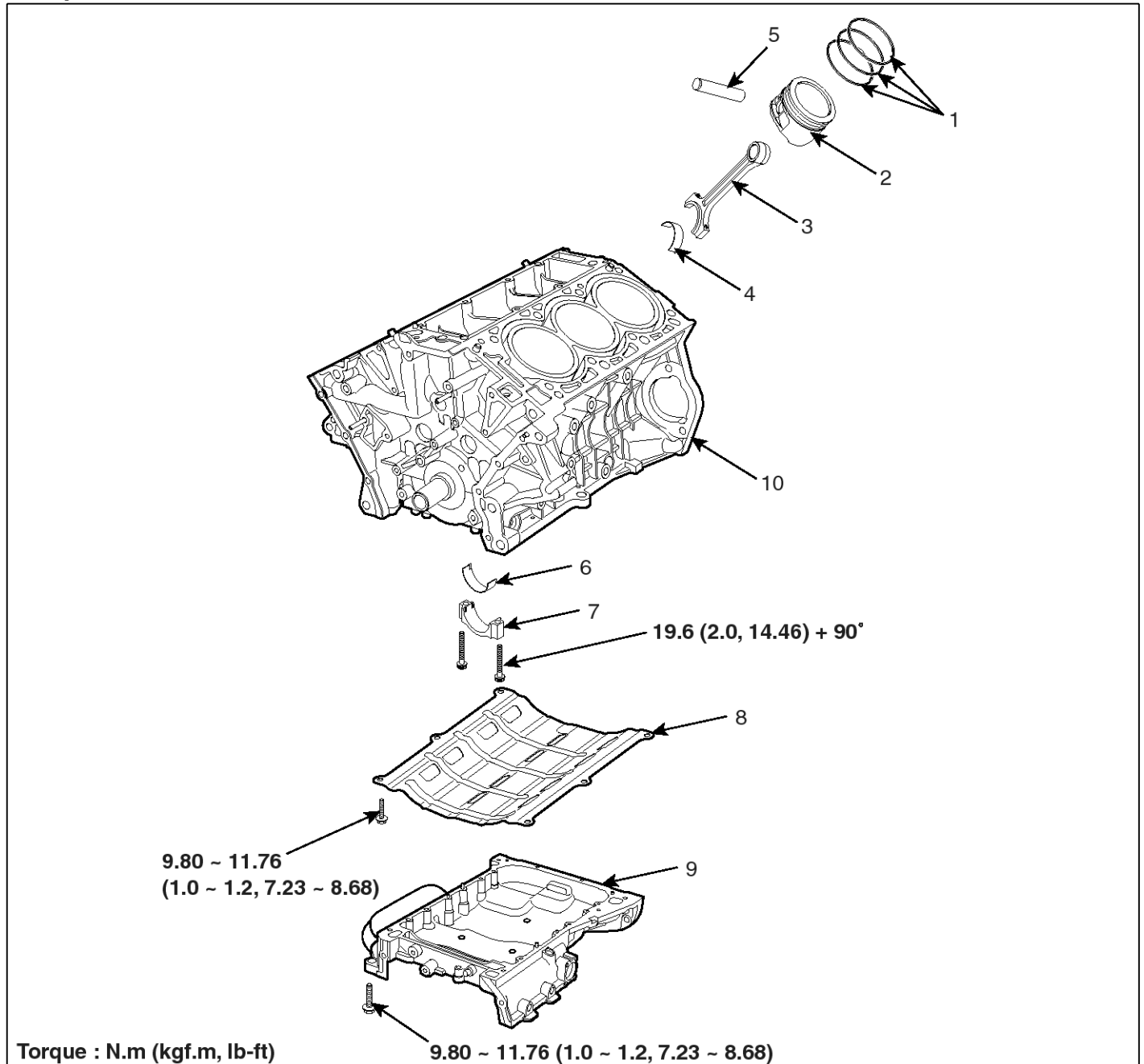

SBHEM9110L

- |                                 |                                 |                    |
|---------------------------------|---------------------------------|--------------------|
| 1. Piston ring                  | 5. Piston pin                   | 8. Baffle plate    |
| 2. Piston                       | 6. Connecting rod lower bearing | 9. Upper oil pan   |
| 3. Connecting rod               | 7. Connecting rod bearing cap   | 10. Cylinder block |
| 4. Connecting rod upper bearing |                                 |                    |

# EM-80

# Engine Mechanical System

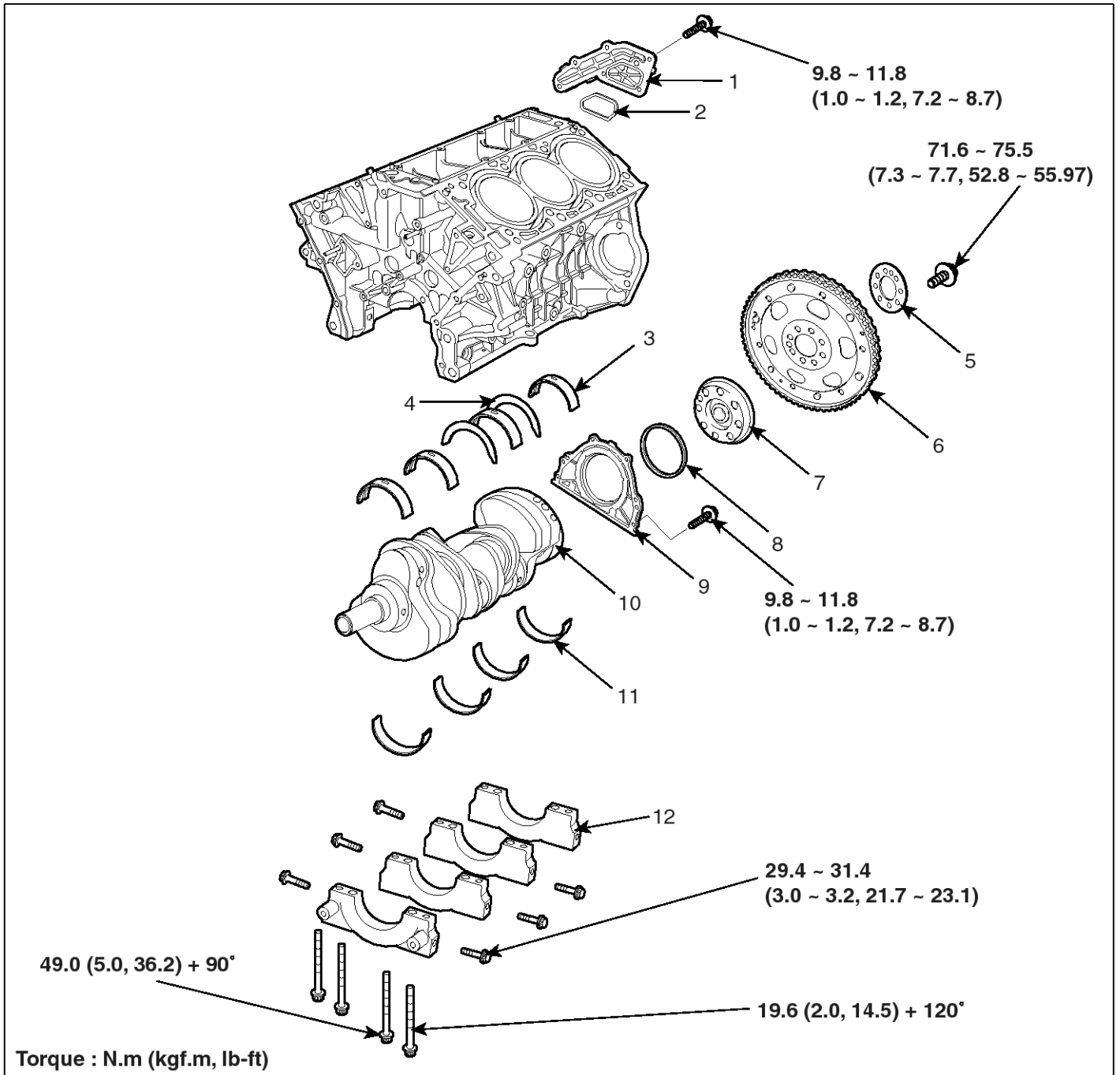

SBHEM9078L

- |                              |                        |                              |
|------------------------------|------------------------|------------------------------|
| 1. Oil drain cover           | 5. Adapter plate       | 9. Rear oil seal case        |
| 2. Oil drain cover gasket    | 6. Drive plate         | 10. Crankshaft               |
| 3. Crank shaft upper bearing | 7. Crank shaft adapter | 11. Crankshaft lower bearing |
| 4. Thrust bearing            | 8. Rear oil seal       | 12. Main bearing cap         |

# Cylinder Block

## Disassembly

### ⚠ CAUTION

- Use fender covers to avoid damaging painted surfaces.
- To avoid damage, unplug the wiring connectors carefully while holding the connector portion.

### 📄 NOTICE

- Mark all wiring and hoses to avoid misconnection.
- Inspect the timing belt before removing the cylinder head.
- Turn the crankshaft pulley so that the No.1 piston is at top dead center.
- Engine removal is required for this procedure.

1. Remove the engine assembly from the vehicle. (Refer to Engine and transmission assembly in this group)
2. Install the engine to engine stand for disassembly.
3. Remove the intake manifold and exhaust manifold. (Refer to Intake and exhaust system in this group)
4. Remove the timing chain. (Refer to Timing system in this group)
5. Remove the water temperature control assembly. (Refer to Cooling system in this group)
6. Remove the cylinder head. (Refer to Cylinder head in this group)
7. Remove the oil pump. (Refer to Lubrication system in this group)
8. Remove the oil filter assembly. (Refer to Lubrication system in this group)
9. Remove the drive plate (A) and adapter plate (B).

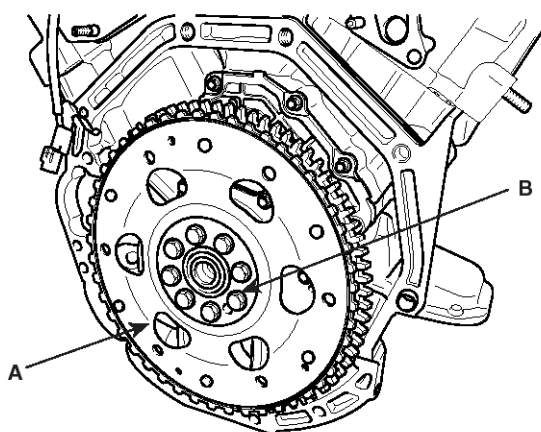

SBHEM8079D

10. Remove the crankshaft adapter (A).

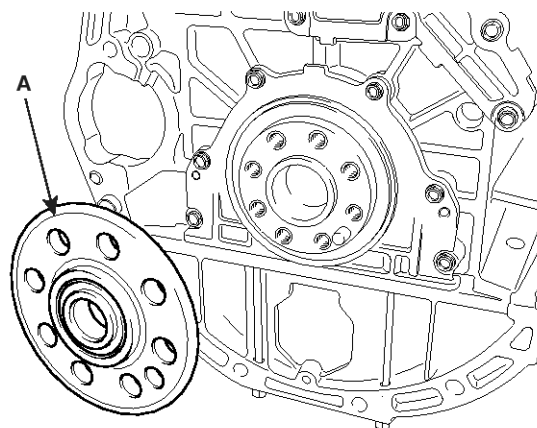

SBHEM8080D

11. Remove the knock sensor (A).

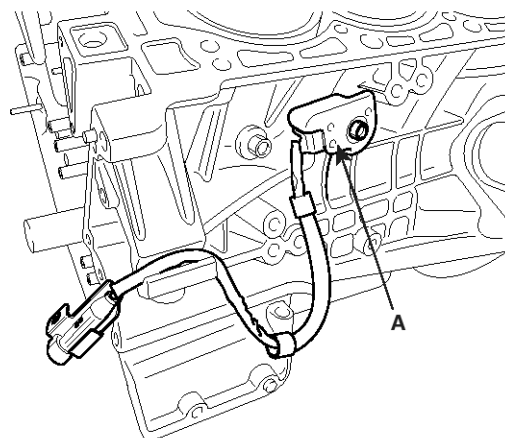

SBHEM8081D

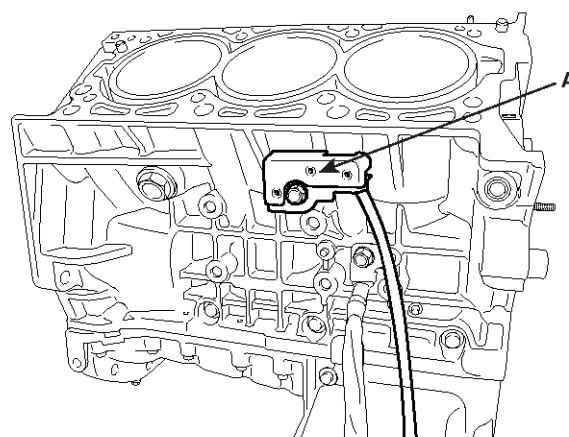

SBHEM8082D

## EM-82

## Engine Mechanical System

12. Remove the upper oil pan (A).

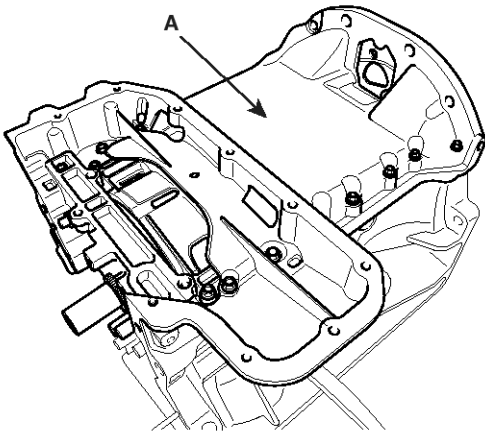

SBHEM8083D

13. Remove the baffle plate (A).

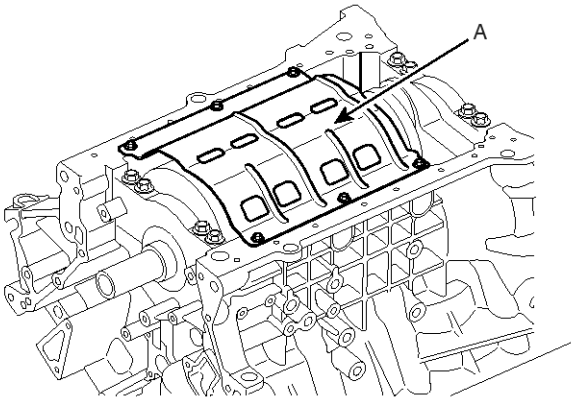

SBHEM8206D

14. Remove the rear oil seal case (A).

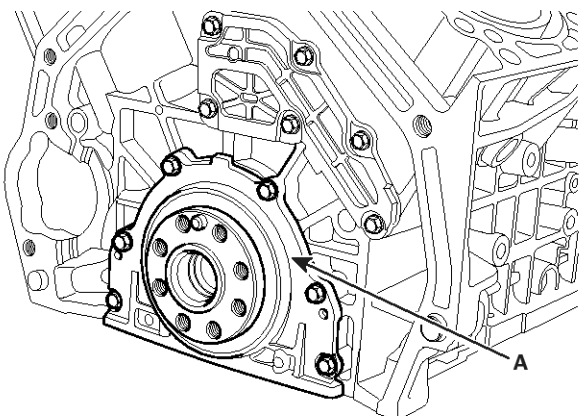

KDRF208A

15. Remove the oil drain cover (A).

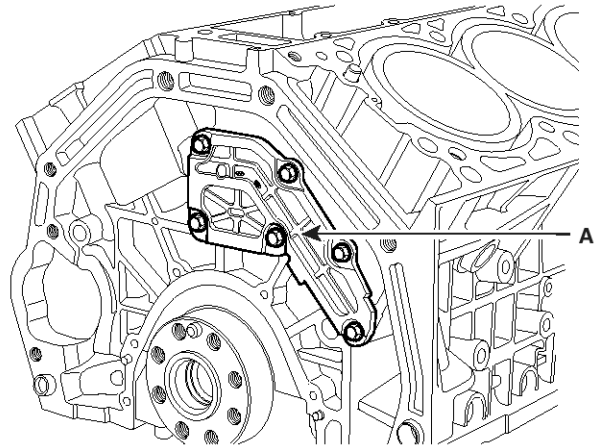

KDRF209A

16. Check the connecting rod end play.

17. Check the connecting rod cap oil clearance.

18. Remove the piston and connecting rod assemblies.

- 1) Using a ridge reamer, remove all the carbon from the top of the cylinder.
- 2) Push the piston, connecting rod assembly and upper bearing through the top of the cylinder block.

### **NOTICE**

- Keep the bearings, connecting rod and cap together.
- Arrange the piston and connecting rod assemblies in the correct order.

19. Remove the crankshaft main bearing cap and check oil clearance.

20. Check the crankshaft end play.

# Cylinder Block

EM-83

21. Lift the crankshaft (A) out of engine, being careful not to damage journals.

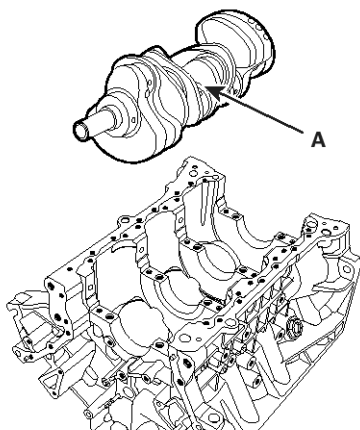

KDRF210A

### **NOTICE**

Arrange the main bearings and thrust bearings in the correct order.

22. Check fit between piston and piston pin.

Try to move the piston back and forth on the piston pin. If any movement is felt, replace piston and piston pin as a set.

23. Remove the piston rings.

- 1) Using a piston ring expander, remove the 2 compression rings.
- 2) Remove 2 side rails and the spacer by hand.

### **NOTICE**

Arrange the piston rings in the correct order only.

24. Disconnect connecting rod from piston. Using a press, remove the piston pin from the piston.

---

**Press-in load** : 800 ~ 1400kg (1764 ~ 3086lb)

---

## Inspection

### Connecting Rod And Crankshaft

1. Check the connecting rod end play.

Using a feeler gauge, measure the end play while moving the connecting rod back and forth.

---

**Standard end play** : 0.1~ 0.25mm(0.004 ~ 0.010in.)

---

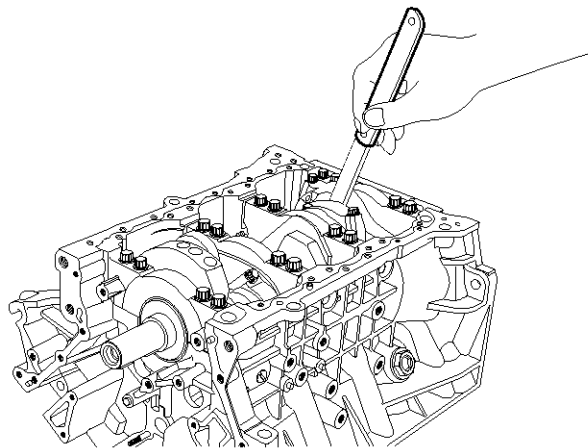

KDRF211A

- If out-of-tolerance, install a new connecting rod.
- If still out-of-tolerance, replace the crankshaft.

## EM-84

# Engine Mechanical System

2. Check the connecting rod bearing oil clearance.
  - 1) Check the matchmarks on the connecting rod and cap are aligned to ensure correct reassembly.
  - 2) Remove 2 connecting rod cap bolts.
  - 3) Remove the connecting rod cap and bearing half.
  - 4) Clean the crank pin and bearing.
  - 5) Place plastigage across the crank pin.
  - 6) Reinstall the bearing half and cap, and torque the bolts.

### Tightening torque

19.6Nm (2.0kgf.m, 14.46lb-ft) + 90°

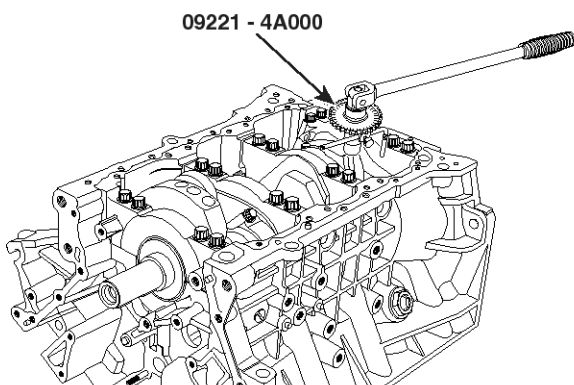

KDRF225A

### NOTICE

Do not turn the crankshaft.

- 7) Remove 2 bolts, connecting rod cap and bearing half.
- 8) Measure the plastigage at its widest point.

### Standard oil clearance

0.038 ~ 0.056mm(0.0015 ~ 0.0022in.)

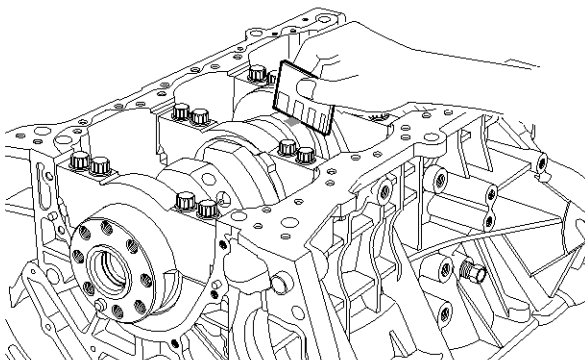

KDRF212A

- 9) If the plastigage measures too wide or too narrow, remove the upper half of the bearing, install a new, complete bearing with the same color mark (select the color as shown in the next column), and recheck the clearance.

### CAUTION

Do not file, shim, or scrape the bearings or the caps to adjust clearance.

- 10) If the plastigage shows the clearance is still incorrect, try the next larger or smaller bearing (the color listed above or below that one), and check clearance again.

### NOTICE

If the proper clearance cannot be obtained by using the appropriate larger or smaller bearings, replace the crankshaft and start over.

### CAUTION

If the marks are indecipherable because of an accumulation of dirt and dust, do not scrub them with a wire brush or scraper. Clean them only with solvent or detergent.

### Connecting Rod Mark Location

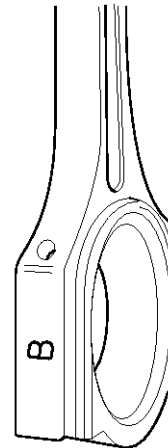

EDQF196A

### Identification Of Connecting Rod

Class	Mark	Inside Diameter
0	a	58.000 ~ 58.006mm (2.2834 ~ 2.2837in.)
1	b	58.006 ~ 58.012mm (2.2837 ~ 2.2839in.)
2	c	58.012 ~ 58.018mm (2.2839 ~ 2.2842in.)

# Cylinder Block

**EM-85**

## Crankshaft Pin Mark Location Identification Of Crankshaft

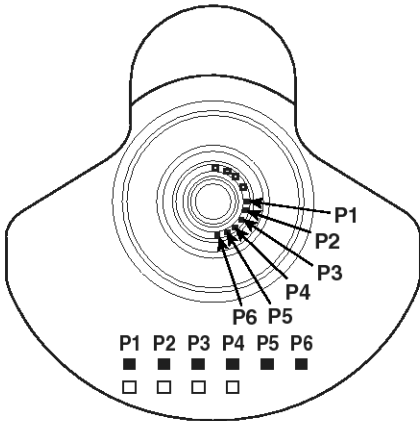

SBHEM8112D

### Discrimination Of Crankshaft

Class	Mark	Outside Diameter Of Pin
I	1 or A	54.966 ~ 54.972mm (2.1640 ~ 2.1642in.)
II	2 or B	54.960 ~ 54.966mm (2.1638 ~ 2.1640in.)
III	3 or C	54.954 ~ 54.960mm (2.1635 ~ 2.1638in.)

## Place Of Identification Mark (Connecting Rod Bearing)

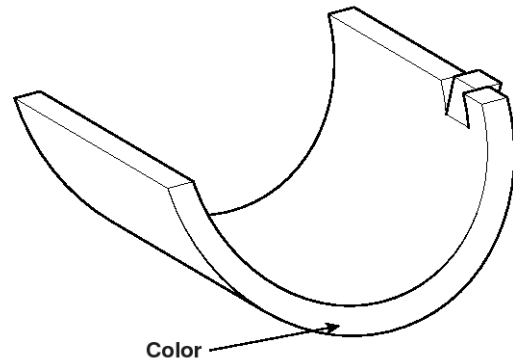

ECRF021A

### Identification Of Connecting Rod Bearing

Class	Mark	Thickness Of Bearing
E	BLUE	1.514 ~ 1.517mm (0.0596 ~ 0.0597in.)
D	BLACK	1.511 ~ 1.514mm (0.0595 ~ 0.0596in.)
C	BROWN	1.508 ~ 1.511mm (0.0594 ~ 0.0595in.)
B	GREEN	1.505 ~ 1.508mm (0.0593 ~ 0.0594in.)
A	YELLOW	1.502 ~ 1.505mm (0.0591 ~ 0.0593in.)

#### 11) Selection

		Connecting Rod Identification Mark		
		0(a)	1(b)	2(c)
Crankshaft Identification Mark	1 or A	A (YELLOW)	B (GREEN)	C (BROWN)
	2 or B	B (GREEN)	C (BROWN)	D (BLACK)
	3 or C	C (BROWN)	D (BLACK)	E (BLUE)

## EM-86

## Engine Mechanical System

3. Check the crankshaft bearing oil clearance.
  - 1) To check main bearing-to-journal oil clearance, remove the main bearing caps and bearing halves.
  - 2) Clean each main journal and bearing half with a clean shop towel.
  - 3) Place one strip of plastigage across each main journal.
  - 4) Reinstall the bearings and caps, then torque the bolts.

### Tightening torque

49.0Nm(5.0 kgf.m, 36.2lb-ft) + 90°

19.6Nm(2.0 kgf.m, 14.5lb-ft) + 120°

29.4 ~ 31.4Nm(3.0 ~ 3.2 kgf.m, 21.7 ~ 23.1lb-ft)

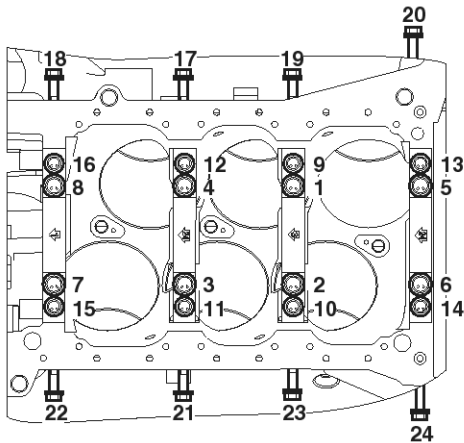

SBHEM8113D

### NOTICE

Do not turn the crankshaft.

- 5) Remove the cap and bearing again, and measure the widest part of the plastigage.

### Standard oil clearance

0.022 ~ 0.040mm (0.0009 ~ 0.0016in.)

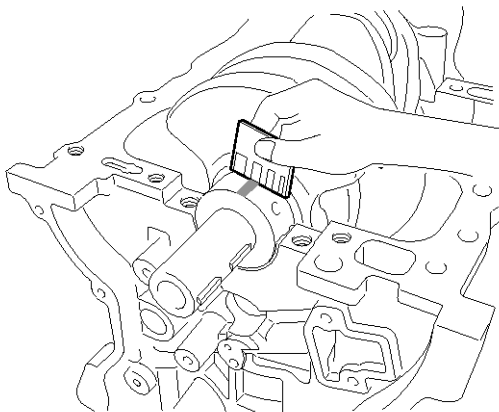

KCRF170A

- 6) If the plastigage measures too wide or too narrow, remove the upper half of the bearing, install a new, complete bearing with the same color mark (select the color as shown in the next column), and recheck the clearance.

### CAUTION

Do not file, shim, or scrape the bearings or the caps to adjust clearance.

- 7) If the plastigage shows the clearance is still incorrect, try the next larger or smaller bearing (the color listed above or below that one), and check clearance again.

### NOTICE

If the proper clearance cannot be obtained by using the appropriate larger or smaller bearings, replace the crankshaft and start over.

### CAUTION

If the marks are indecipherable because of an accumulation of dirt and dust, do not scrub them with a wire brush or scraper. Clean them only with solvent or detergent.

### Crankshaft bore mark location

Letters have been stamped on the block as a mark for the size of each of the 4 main journal bores.

Use them, and the numbers or bar stamped on the crank (marks for main journal size), to choose the correct bearings.

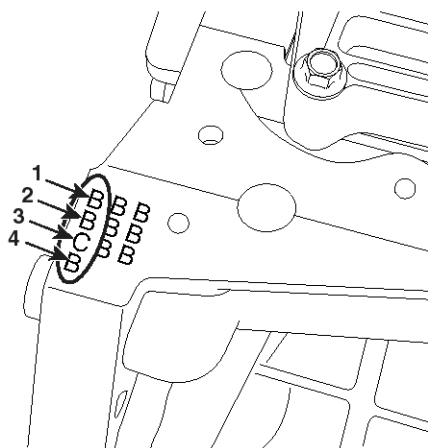

ECBF038A

# Cylinder Block

EM-87

## Discrimination Of Cylinder Block

Class	Mark	Inside Diameter
a	A	73.500 ~ 73.506mm (2.8937 ~ 2.8939in.)
b	B	73.506 ~ 73.512mm (2.8939 ~ 2.8942in.)
c	C	73.512 ~ 73.518mm (2.8942 ~ 2.8944in.)

## Crankshaft Journal Mark Location

### Discrimination Of Crankshaft

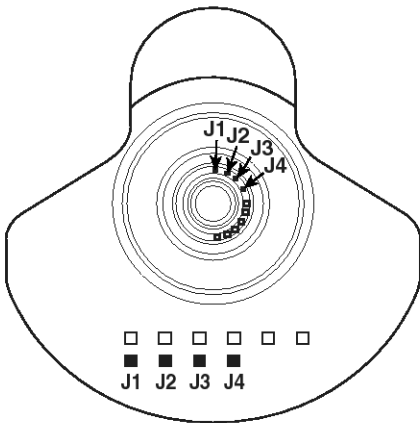

SBHEM8114D

## Discrimination Of Crankshaft

Class	Mark	Outside Diameter Of Journal
I	1 or A	68.954 ~ 68.960mm (2.7147 ~ 2.7150in.)
II	2 or B	68.948 ~ 68.954mm (2.7145 ~ 2.7147in.)
III	3 or C	68.942 ~ 68.948mm (2.7142 ~ 2.7145in.)

## Place Of Identification Mark (Crankshaft Bearing)

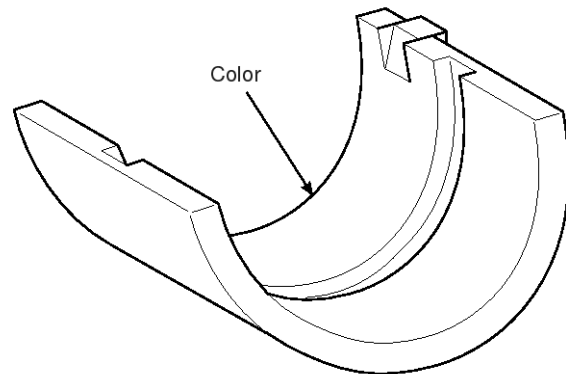

ECRF022A

## Discrimination Of Crankshaft Bearing

Class	Mark	Thickness Of Bearing
E	BLUE	2.277 ~ 2.280mm (0.0896 ~ 0.0897in.)
D	BLACK	2.274 ~ 2.277mm (0.0895 ~ 0.0896in.)
C	BROWN	2.271 ~ 2.274mm (0.0894 ~ 0.0895in.)
B	GREEN	2.268 ~ 2.271mm (0.0893 ~ 0.0894in.)
A	YELLOW	2.265 ~ 2.268mm (0.0892 ~ 0.0893in.)

## Selection

		Crankshaft Bore Identification Mark		
		a(A)	b(B)	c(C)
Crankshaft Identification Mark	1 or A	A (YELLOW)	B (GREEN)	C (BROWN)
	2 or B	B (GREEN)	C (BROWN)	D (BLACK)
	3 or C	C (BROWN)	D (BLACK)	E (BLUE)

## EM-88

## Engine Mechanical System

### 4. Check crankshaft end play.

Using a dial indicator, measure the thrust clearance while prying the crankshaft back and forth with a screwdriver.

#### Standard end play

0.10 ~ 0.28mm (0.0039 ~ 0.0110in.)

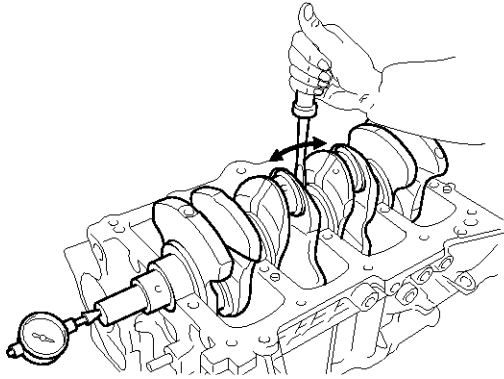

ECKD001B

If the end play is greater than maximum, replace the thrust bearings as a set.

#### Thrust bearing thickness

2.41 ~ 2.45mm(0.0949 ~ 0.0964in.)

### 5. Inspect main journals and crank pins

Using a micrometer, measure the diameter of each main journal and crank pin.

#### Main journal diameter :

68.942 ~ 68.960mm (2.7142 ~ 2.7149in.)

#### Crank pin diameter :

54.954 ~ 54.972mm (2.1635 ~ 2.1642in.)

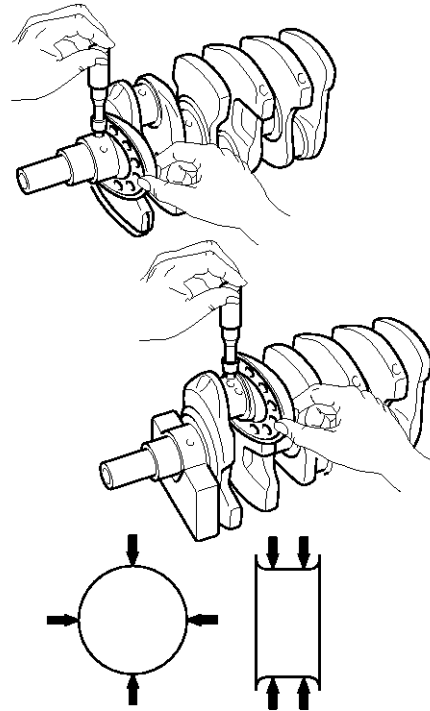

ECKD001E

## Connecting Rods

1. When reinstalling, make sure that cylinder numbers put on the connecting rod and cap at disassembly match. When a new connecting rod is installed, make sure that the notches for holding the bearing in place are on the same side.
2. Replace the connecting rod if it is damaged on the thrust faces at either end. Also if step wear or a severely rough surface of the inside diameter of the small end is apparent, the rod must be replaced as well.
3. Using a connecting rod aligning tool, check the rod for bend and twist. If the measured value is close to the repair limit, correct the rod by a press. Any connecting rod that has been severely bent or distorted should be replaced.

---

### Allowable bend of connecting rod :

0.05mm / 100mm (0.0020 in./3.94 in.) or less

### Allowable twist of connecting rod :

0.1mm / 100mm (0.0039 in./3.94 in.) or less

---

## Cylinder Block

1. Remove the gasket material.  
Using a gasket scraper, remove all the gasket material from the top surface of the cylinder block.
2. Clean the cylinder block  
Using a soft brush and solvent, thoroughly clean the cylinder block.
3. Inspect the top surface of the cylinder block for flatness.  
Using a precision straight edge and feeler gauge, measure the surface contacting the cylinder head gasket for warpage.

---

Flatness of cylinder block gasket surface  
Standard : Less than 0.05mm(0.0020 in.),  
Less than 0.02mm(0.0008in.) / 150 x 150

---

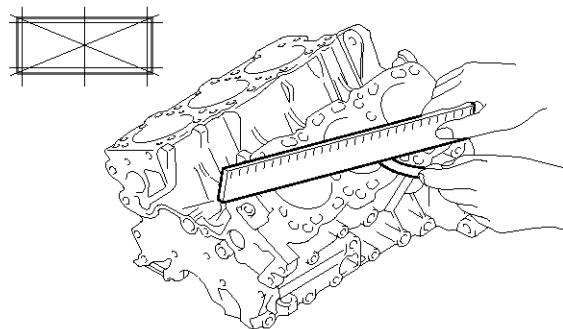

EDQF154A

## EM-90

## Engine Mechanical System

### 4. Inspect cylinder bore diameter

Visually check the cylinder for vertical scratches.

If deep scratches are present, replace the cylinder block.

### 5. Inspect cylinder bore diameter

Using a cylinder bore gauge, measure the cylinder bore diameter at position in the thrust and axial directions.

#### Standard diameter

96.00 ~ 96.03mm (3.7795 ~ 3.7807in.)

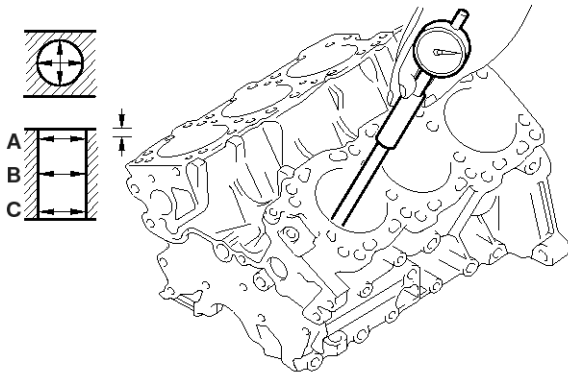

EDQF153A

### 6. Check the cylinder bore size code on the cylinder block.

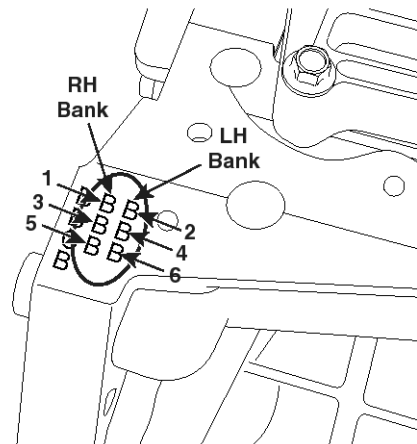

ECBF002A

Class	Size code	Cylinder bore inner diameter
A	A	96.00~96.01mm (3.7795~3.7799in.)
B	B	96.01~96.02mm (3.7799~3.7803in.)
C	C	96.02~96.03mm (3.7803~3.7807in.)

# Cylinder Block

# EM-91

7. Check the piston size code(A) and the front mark(B) on the piston top face.

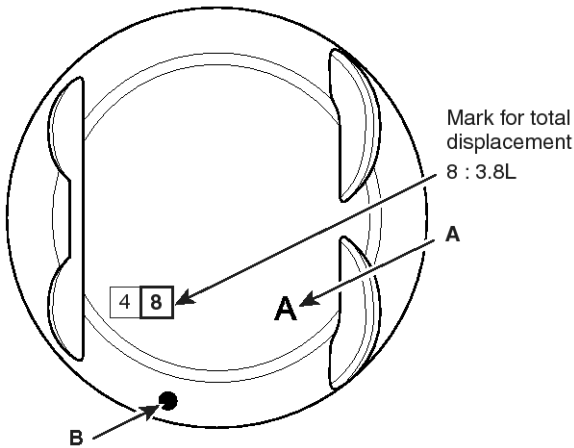

SGHEM7002N

Class	Size code	Piston outer diameter
A	A	95.96~95.97mm (3.7779~3.7783in.)
B	B	95.97~95.98mm (3.7783~3.7787in.)
C	C	95.98~95.99mm (3.7787~3.7791in.)

8. Select the piston related to cylinder bore class.

**Clearance** : 0.03 ~ 0.05mm(0.0012 ~ 0.0020in.)

## Piston And Rings

1. Clean piston

- 1) Using a gasket scraper, remove the carbon from the piston top.
- 2) Using a groove cleaning tool, clean the piston ring grooves.
- 3) Using solvent and a brush, thoroughly clean the piston.

### NOTICE

*Do not use a wire brush.*

2. The standard measurement of the piston outside diameter is taken 14 mm (0.5512 in.) from the bottom of the piston.

### Standard diameter

95.96 ~ 95.99mm (3.7779 ~ 3.7791in.)

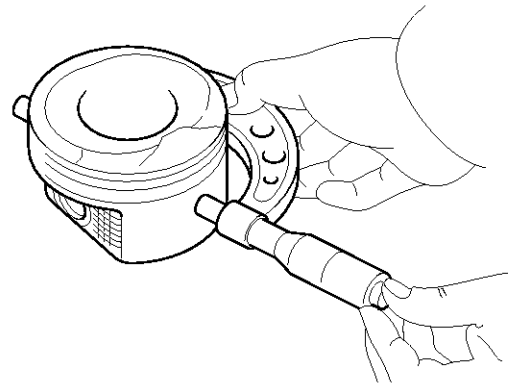

ECKD001D

## EM-92

## Engine Mechanical System

3. Calculate the difference between the cylinder bore diameter and the piston diameter.

### Piston-to-cylinder clearance

0.03 ~ 0.05mm (0.0012 ~ 0.0020in.)

4. Inspect the piston ring side clearance.

Using a feeler gauge, measure the clearance between new piston ring and the wall of the ring groove.

### Piston ring side clearance

Standard

No.1 : 0.03 ~ 0.07mm (0.0012 ~ 0.0027in.)

No.2 : 0.03 ~ 0.07mm (0.0012 ~ 0.0027in.)

Oil ring : 0.06 ~ 0.15mm (0.0024 ~ 0.0059in.)

Limit

No.1 : 0.1mm (0.004in.)

No.2 : 0.1mm (0.004in.)

Oil ring : 0.2mm (0.008in.)

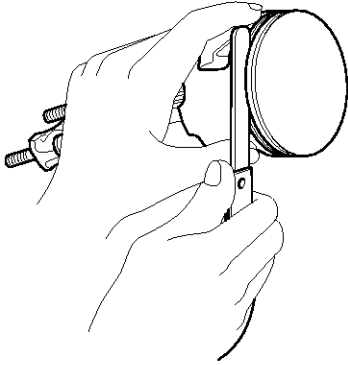

ECKD001G

If the clearance is greater than maximum, replace the piston.

5. Inspect piston ring end gap.

To measure the piston ring end gap, insert a piston ring into the cylinder bore. Position the ring at right angles to the cylinder wall by gently pressing it down with a piston. Measure the gap with a feeler gauge. If the gap exceeds the service limit, replace the piston ring. If the gap is too large, recheck the cylinder bore diameter against the wear limits. If the bore is over the service limit, the cylinder block must be replaced.

### Piston ring end gap

Standard

No.1 : 0.17 ~ 0.32mm (0.0067 ~ 0.0126in.)

No.2 : 0.32 ~ 0.47mm (0.0126 ~ 0.0185in.)

Oil ring : 0.20 ~ 0.70mm (0.0079 ~ 0.0275in.)

Limit

No.1 : 0.6mm (0.0236in.)

No.2 : 0.7mm (0.0275in.)

Oil ring : 0.8mm (0.0315in.)

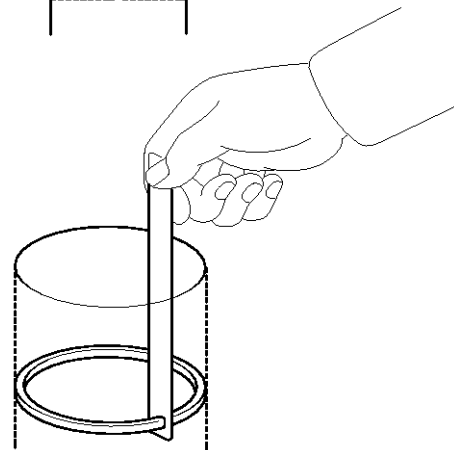
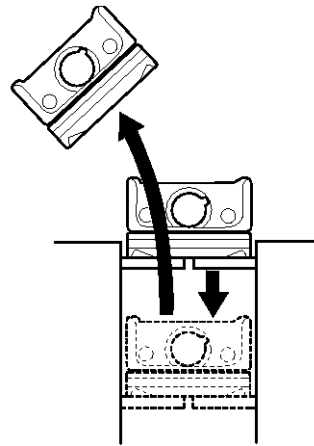

ECKD001K

# Cylinder Block

EM-93

## Piston Pins

1. Measure the diameter of the piston pin.

### Piston pin diameter

23.001 ~ 23.006mm (0.9056 ~ 0.9057in.)

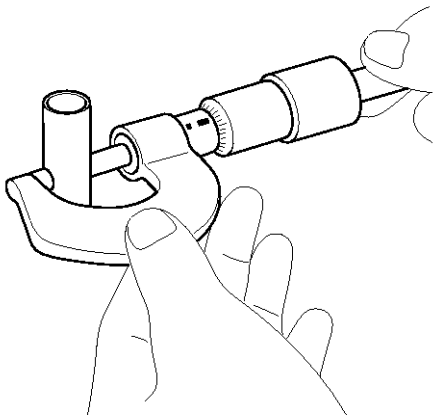

ECKD001Z

2. Measure the piston pin-to-piston clearance.

### Piston pin-to-piston clearance

0.01 ~ 0.02mm (0.0004 ~ 0.0008in.)

3. Check the difference between the piston pin diameter and the connecting rod small end diameter.

### Piston pin-to-connecting rod interference

-0.032 ~ -0.016mm (-0.0012 ~ -0.0007in.)

## Reassembly

### NOTICE

- Thoroughly clean all parts to be assembled.
- Before installing the parts, apply fresh engine oil to all sliding and rotating surfaces.
- Replace all gaskets, O-rings and oil seals with new parts.

1. Assemble the piston and the connecting rod.
  - 1) Use a hydraulic press for installation.
  - 2) The piston front mark and the connecting rod front mark must face the timing belt side of the engine.

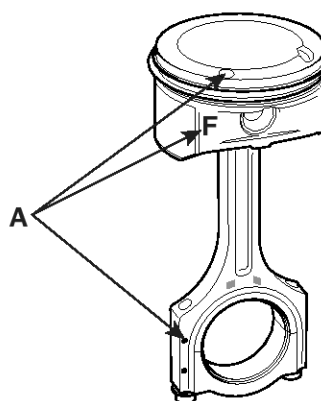

SGHEM7012N

2. Install the piston rings.
  - 1) Install the oil ring spacer and 2 side rails by hand.
  - 2) Using a piston ring expander, install the 2 compression rings with the code mark facing upward.
  - 3) Position the piston rings so that the ring ends are as shown.

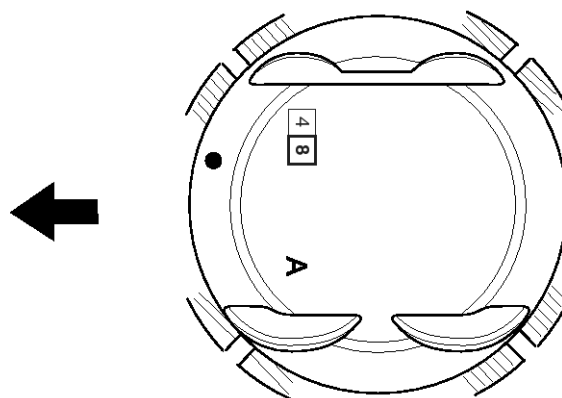

SBHEM8153D

## EM-94

## Engine Mechanical System

### 3. Install the connecting rod bearings.

- 1) Align the bearing claw with the groove of the connecting rod or connecting rod cap.
- 2) Install the bearings(A) in the connecting rod and connecting rod cap(B).

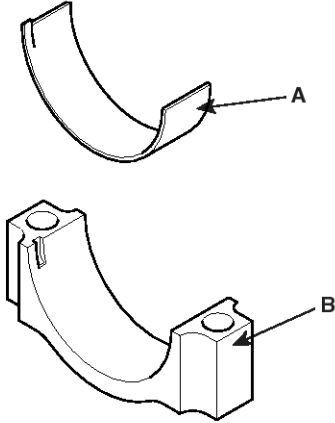

SGHEM7013N

### 4. Install the main bearings.

#### **NOTICE**

Upper bearings have an oil groove of oil holes;  
Lower bearings do not.

- 1) Align the bearing claw with the claw groove of the cylinder block, push in the 4 upper bearings(A).

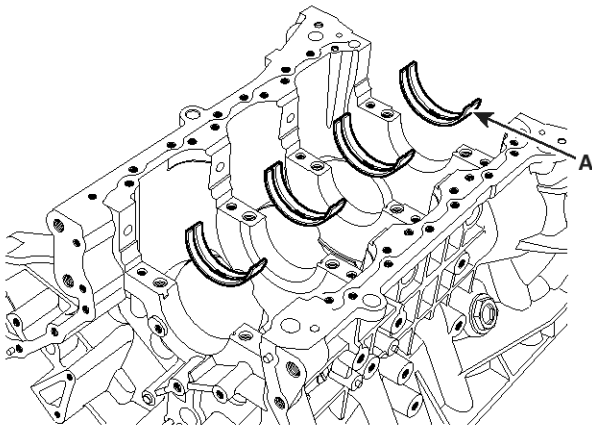

KDRF216A

- 2) Align the bearing claw with the claw groove of the main bearing cap, and push in the 4 lower bearings.

### 5. Install the thrust bearings.

Install the 2 thrust bearings(A) under the No.3 journal position of the cylinder block with the oil grooves facing outward.

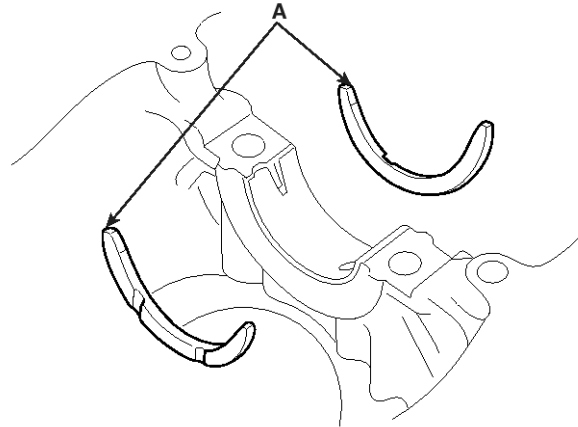

ECKD324A

### 6. Place the crankshaft(A) on the cylinder block.

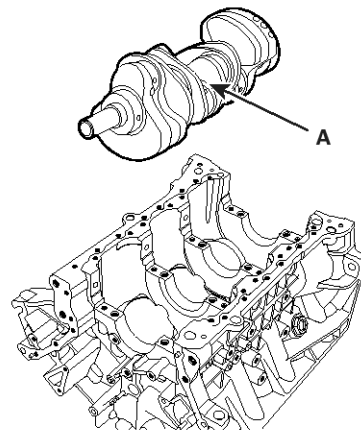

KDRF210A

# Cylinder Block

# EM-95

7. Place the main bearing caps on cylinder block.
8. Install the main bearing cap bolts.
  - 1) Install and uniformly tighten the bearing cap bolts, in several passes, in the sequence shown.

### Tightening torque

Main bearing cap bolt

49.0N.m (5.0 kgf.m, 36.2lb-ft) + 90° (1 ~ 8)

19.6N.m (2.0 kgf.m, 14.5lb-ft) + 120° (9 ~ 16)

29.4 ~ 31.4N.m (3.0 ~ 3.2 kgf.m, 21.7 ~ 23.1lb-ft) (17 ~ 24)

### NOTICE

- Always use new main bearing cap bolts.
- If any of the bearing cap bolts are broken or deformed, replace it.

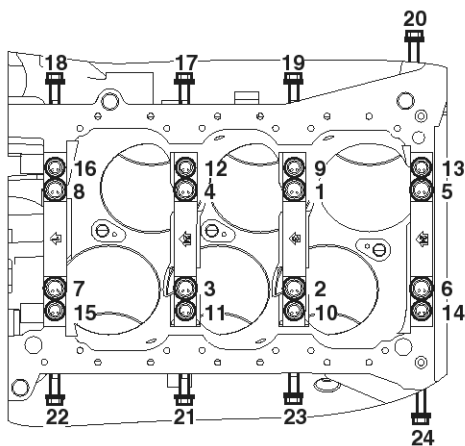

SBHEM8113D

Use the SST( 09221-4A000 ), install main bearing cap bolts.

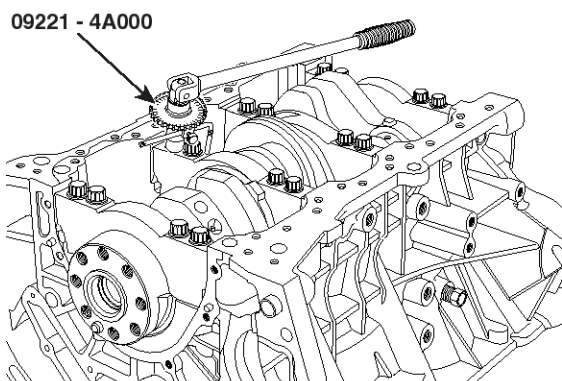

KDRF224A

- 2) Check that the crankshaft turns smoothly.

9. Check crankshaft end play.
10. Install the piston and connecting rod assemblies.

### NOTICE

Before installing the pistons, apply a coat of engine oil to the ring grooves and cylinder bores.

- 1) Install the ring compressor, check that the bearing is securely in place, then position the piston in the cylinder, and tap it in using the wooden handle of a hammer.
- 2) Stop after the ring compressor pops free, and check the connecting rod-to-check journal alignment before pushing the piston into place.
- 3) Apply engine oil to the bolt threads. Install the rod caps with bearings, and torque the bolts.

### Tightening torque

19.6N.m (2.0kgf.m, 14.5lb-ft) + 90°

Use SST(09221-4A000), install connecting rod bearing cap bolts.

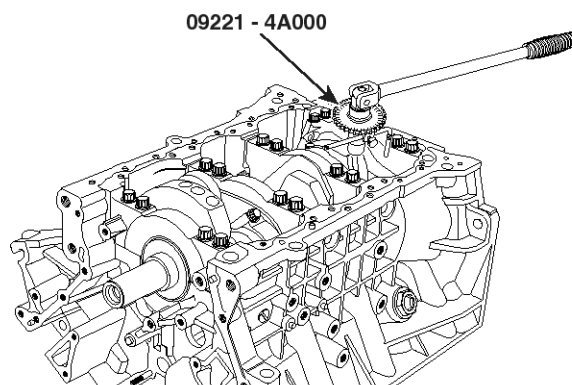

KDRF225A

## EM-96

## Engine Mechanical System

### NOTICE

- Always use new connecting rod bearing cap bolts.
- Maintain downward force on the ring compressor to prevent the rings from expanding before entering the cylinder bore.

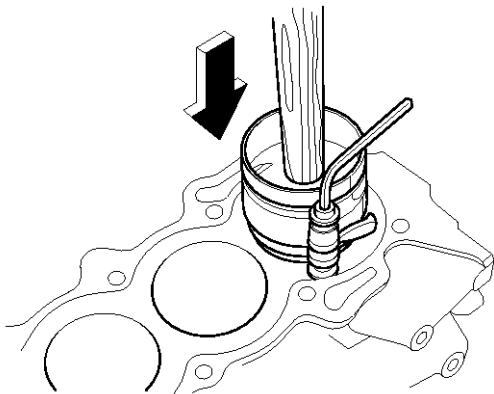

ECKD001F

11. Check the connecting rod end play.

12. Install the oil drain cover(A).

### Tightening torque

9.8 ~ 11.8N.m (1.0 ~ 1.2kgf.m, 7.2 ~ 8.7lb-ft)

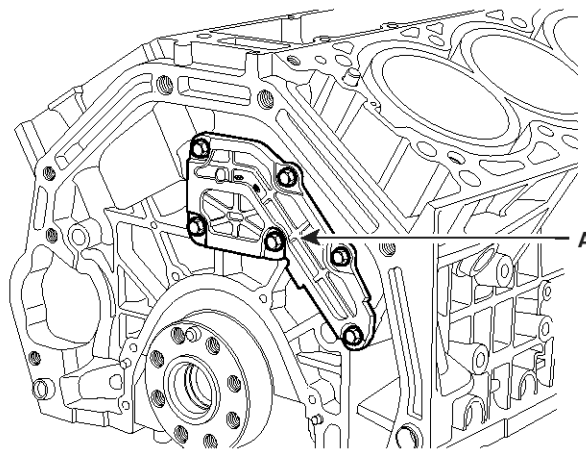

KDRF209A

### NOTICE

- Clean the sealing face before assembling two parts.
- Remove harmful foreign materials on the sealing face before applying sealant
- Before assembling oil drain cover, the liquid sealant TB1217H should be applied to the oil drain cover.
- The part must be assembled within 5 minutes after sealant was applied.
- Apply sealant to the inner threads of the bolt holes.

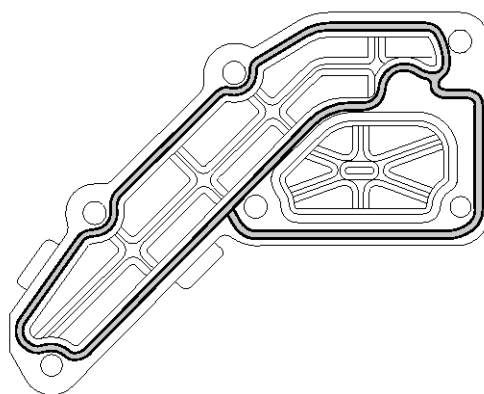

SBHEM8115D

# Cylinder Block

# EM-97

13. Install the rear oil seal case(A).

**Tightening torque**

9.8 ~ 11.8N.m (1.0 ~ 1.2kgf.m, 7.2 ~ 8.7lb-ft)

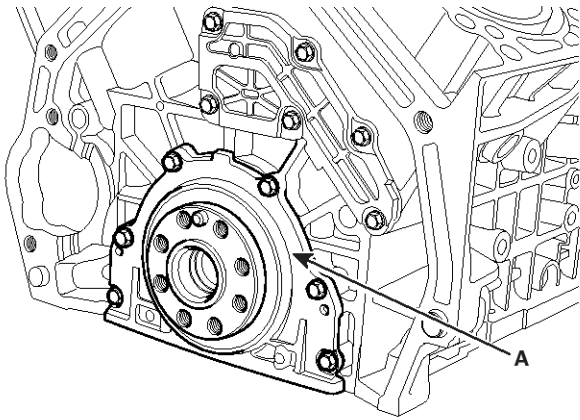

KDRF208A

**NOTICE**

- Clean the sealing face before assembling two parts.
- Remove harmful foreign materials on the sealing face before applying sealant
- Before assembling rear oil seal case, the liquid sealant TB1217H should be applied to the rear oil seal case.
- The part must be assembled within 5 minutes after sealant was applied.
- Apply sealant to the inner threads of the bolt holes.

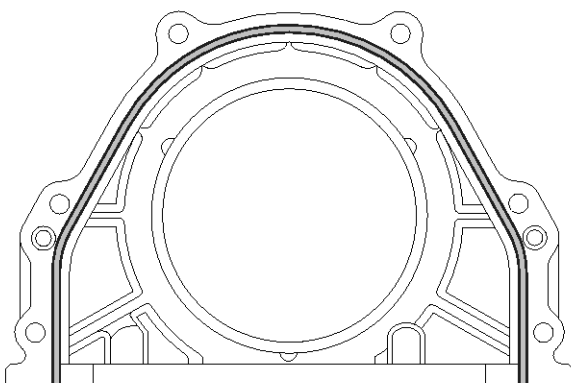

KDRF218A

14. Using the SST(09231-3C200, 09231-H1100), install rear oil seal.

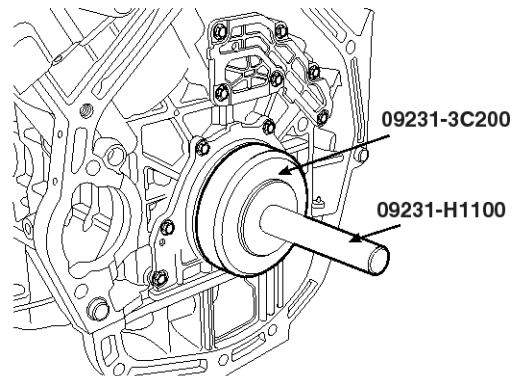

KDRF237A

15. Install the baffle plate.

Install and uniformly tighten the baffle plate bolts, in several passes, in the sequence shown.

**Tightening torque**

9.8 ~ 11.8N.m (1.0 ~ 1.2kgf.m, 7.2 ~ 8.7lb-ft)

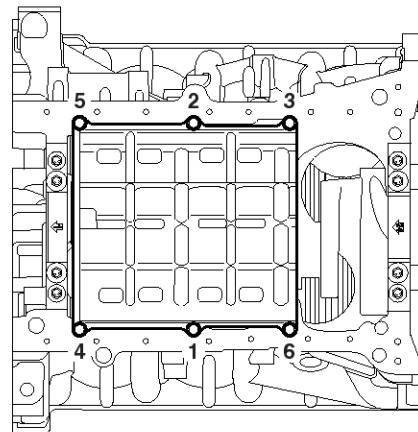

SBHEM8116D

## EM-98

## Engine Mechanical System

16. Install the upper oil pan.

- a. Using a gasket scraper, remove all the old packing material from the gasket surfaces.
- b. Before assembling the oil pan, the liquid sealant TB1217H should be applied on upper oil pan.

The part must be assembled within 5 minutes after the sealant was applied.

**Bead width : 2.5mm(0.1in.)**

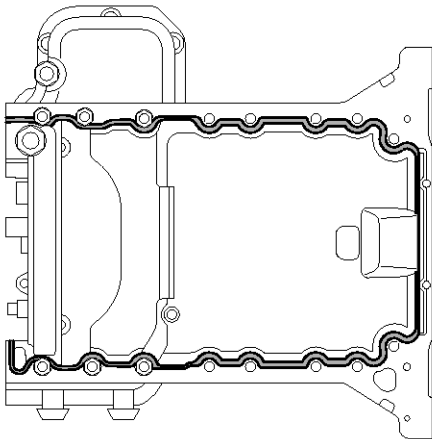

SBHEM8097D

### NOTICE

- Clean the sealing face before assembling two parts.
- Remove harmful foreign materials on the sealing face before applying sealant
- When applying sealant gasket, sealant must not protrude into the inside of oil pan.
- To prevent leakage of oil, apply sealant gasket to the inner threads of the bolt holes.

c. Install the upper oil pan.

Uniformly tighten the bolts in several passes.

### Tightening torque

9.8 ~ 11.8N.m (1.0 ~ 1.2kgf.m, 7.2 ~ 8.7lb-ft)

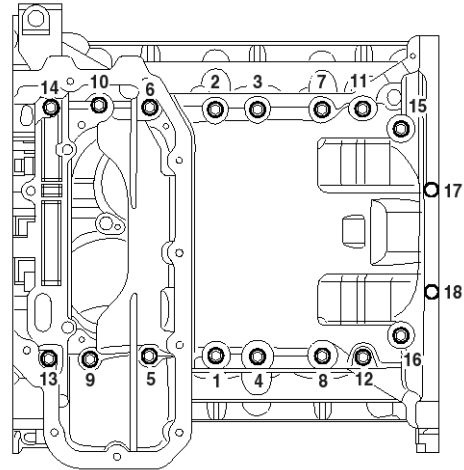

SBHEM8098D

# Cylinder Block

# EM-99

17. Install the knock sensor(A).

**Tightening torque**

15.7 ~ 23.5N.m (1.6 ~ 2.4kgf.m, 11.6 ~ 17.3lb-ft)

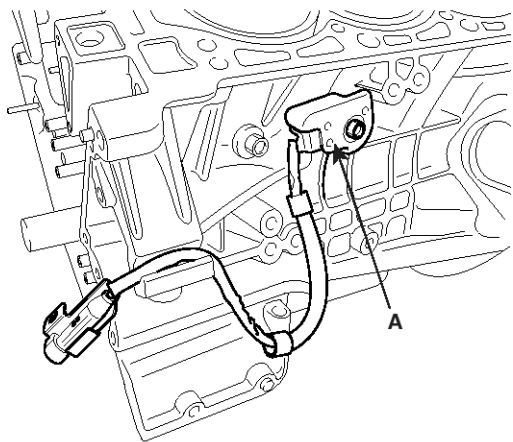

SBHEM8081D

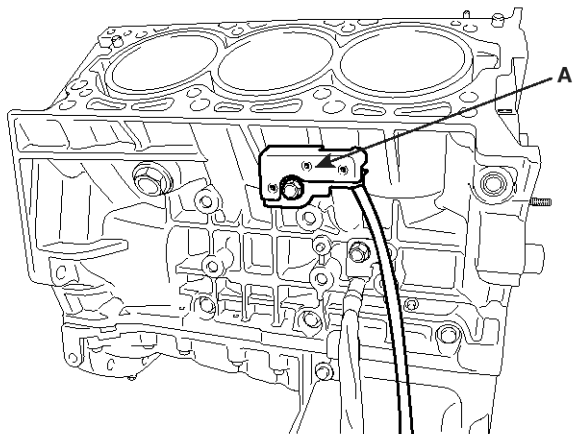

SBHEM8082D

18. Install the crankshaft adapter (A).

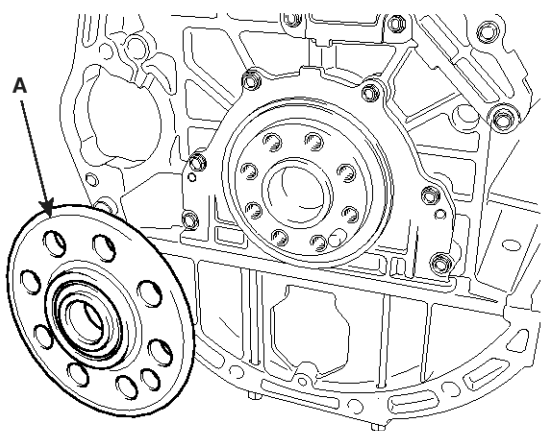

SBHEM8080D

19. Install the drive plate (A) and adapter plate (B).

**Tightening torque :**

71.6 ~ 75.5N.m (7.3 ~ 7.7kgf.m, 52.8 ~ 55.7lb-ft)

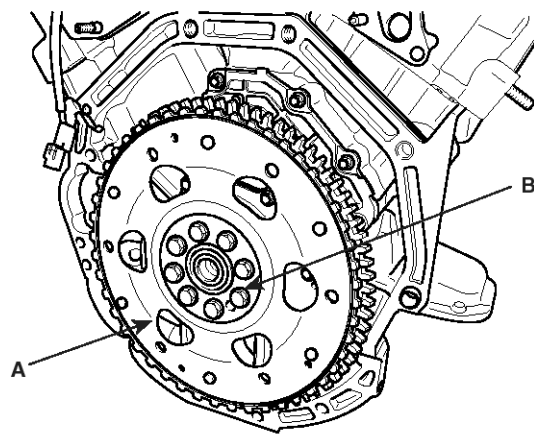

SBHEM8079D

20. Install the oil filter assembly. (Refer to Lubrication system in this group)

21. Install the oil pump. (Refer to Lubrication system in this group)

22. Install the cylinder head. (Refer to Cylinder head in this group)

23. Install the water temperature control assembly. (Refer to Cooling system in this group)

24. Install the timing chain. (Refer to Timing system in this group)

25. Install the intake manifold and exhaust manifold. (Refer to Intake and exhaust system in this group)

26. Install the engine assembly to the vehicle. (Refer to Engine and transmission assembly in this group)

## Cooling System

### Coolant

#### Replacement And Air Bleeding

##### CAUTION

Never remove the radiator cap when the engine is hot. Serious scalding could be caused by hot fluid under high pressure escaping from the radiator.

##### NOTICE

When pouring engine coolant, be sure to shut the relay box lid and not to let coolant spill on the electrical parts or the paint. If any coolant spills, rinse it off immediately.

1. Make sure the engine and radiator are cool to the touch.
2. Remove the radiator cap.
3. Loosen the drain plug, and drain the coolant.
4. Tighten the radiator drain plug securely.
5. Remove, drain and reinstall the reservoir. Fill the tank halfway to the MAX mark with water, then up to the MAX mark with antifreeze.
6. Fill the radiator with water through the radiator cap and tighten the cap.

##### NOTICE

To most effectively bleed the air, pour the water slowly and press on the upper / lower radiator hoses.

7. Start the engine and allow to come to normal operating temperature. Wait for the cooling fans to turn on several times. Accelerate the engine to aid in purging trapped air. Shut engine off.
8. Wait until the engine is cool.
9. Repeat steps 1 to 8 until the drained water runs clear.

10. Fill fluid mixture with coolant and water (5 : 5) (Tropical region – 4:6) slowly through the radiator cap. Push the upper/lower hoses of the radiator so as bleed air easily.

##### NOTICE

- Use only genuine antifreeze/coolant.
- For best corrosion protection, the coolant concentration must be maintained year-round at 35% minimum. Coolant concentrations less than 35% may not provide sufficient protection against corrosion or freezing.
- Coolant concentrations greater than 60% will impair cooling efficiency and are not recommended.

##### CAUTION

- Do not mix different brands of antifreeze/coolants.
- Do not use additional rust inhibitors or antirust products; they may not be compatible with the coolant.

11. Start the engine and run coolant circulates.
12. When the cooling fan operates and coolant circulates, refill coolant through the radiator cap.
13. Repeat step.11 until the cooling fan 3 ~ 5times and bleed air sufficiently out of the cooling system.
14. Install the radiator cap and fill the reservoir tank to the "MAX" line with coolant.
15. Run the vehicle under idle until the cooling fan operates 2 ~ 3 times.
16. Stop the engine and wait coolant gets cool.
17. Repeat 10 to 15 until the coolant level doesn't fall any more, bleed air out of the cooling system.

##### NOTICE

As it is to bleed air out to the cooling system and refill coolant when coolant gets cool completely, recheck the coolant level in the reservoir tank for 2 ~ 3 days after replacing coolant.

---

#### Coolant capacity :

11.4L (12.0 Us.qts, 10.0 Imp.qts)

---

# Cooling System

EM-101

## Radiator

### Components

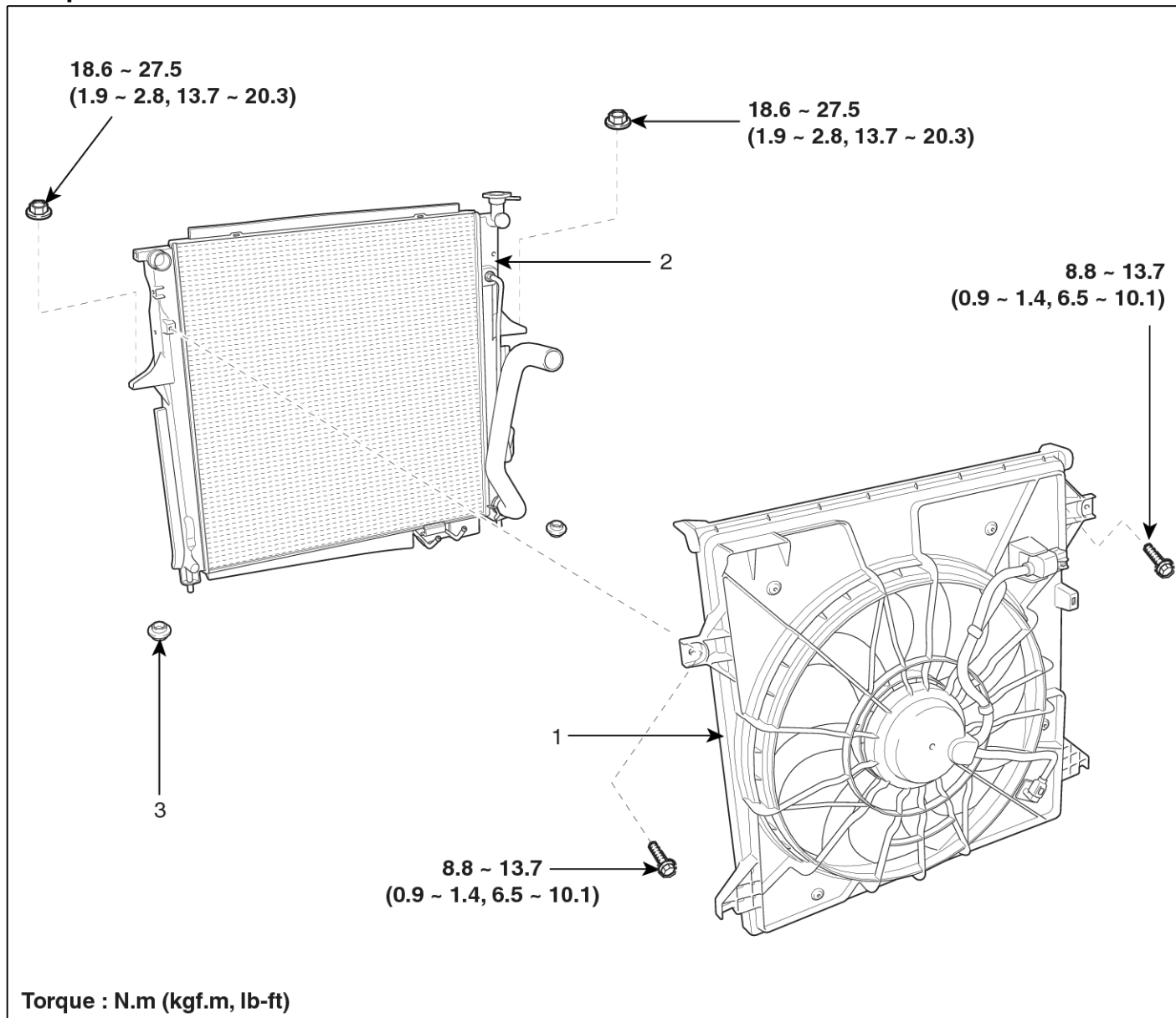

SHMEM9022L

- 1. Cooling module assembly
- 2. Radiator assembly

- 3. Lower mounting insulator

## EM-102

## Engine Mechanical System

### Inspection

#### Cap Testing

1. Remove the radiator cap, wet its seal with engine coolant, then install it to pressure tester.

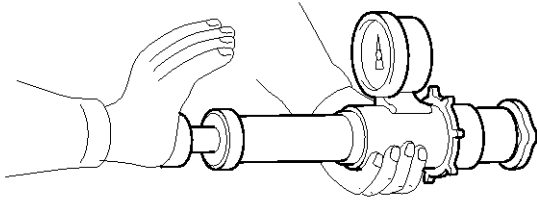

ECKD501X

2. Apply a pressure of 93 ~ 123kPa (0.95 ~ 1.25kgf/cm<sup>2</sup>, 14 ~ 19psi).
3. Check for a drop in pressure.
4. If the pressure drops, replace the cap.

### Radiator Leakage

1. Wait until engine is cool, then carefully remove the radiator cap and fill the radiator with engine coolant, then install a pressure tester on it.

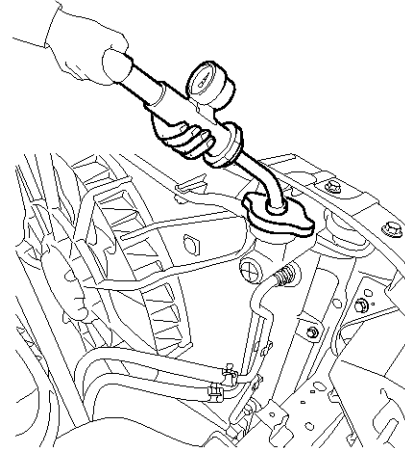

SBHEM8137D

2. Apply a pressure of 93 ~ 123kPa (0.95 ~ 1.25kgf/cm<sup>2</sup>, 14 ~ 19psi).
3. Inspect for engine coolant leaks and a drop in pressure.
4. If the pressure drops, check hoses, the radiator and the water pump for leakage. If there is no leakage, inspect the heater core, the cylinder block and the cylinder head.
5. Remove the tester and reinstall the radiator cap.

#### NOTICE

Check for engine oil in coolant and/or coolant in engine oil.

# Cooling System

# EM-103

## Removal

1. Disconnect the negative cable (A) from the battery.

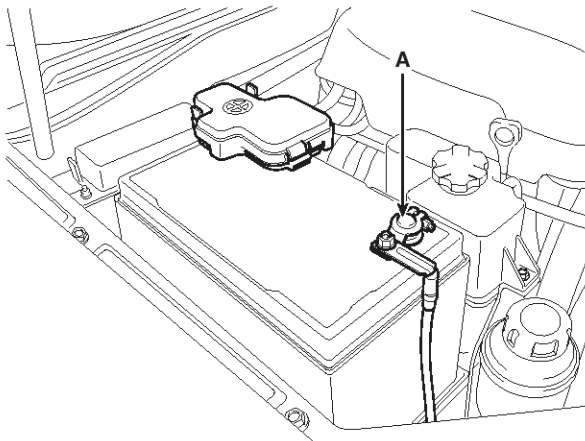

SHMM19043N

2. Remove the engine cover (A).

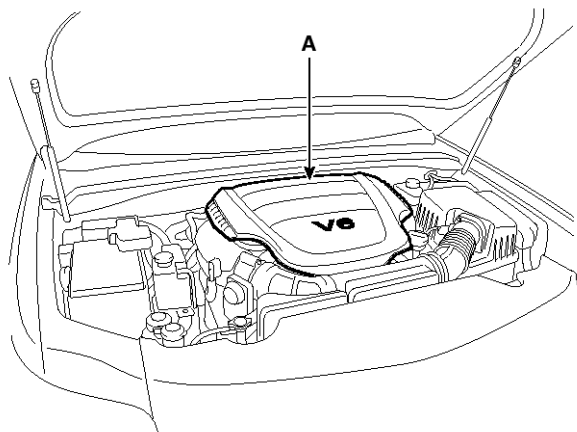

SHMEM9001L

3. Remove the radiator grill upper guard (A).

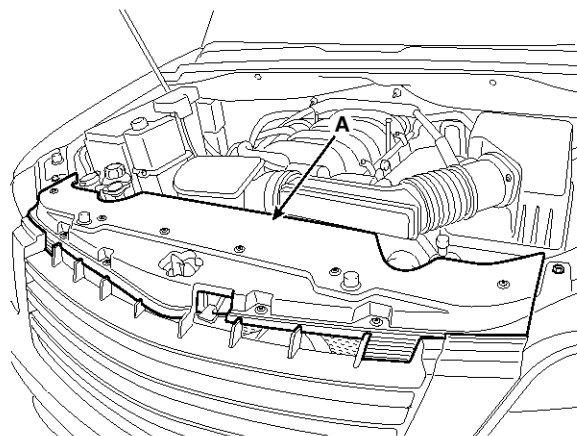

SHMM19045N

4. Loosen the drain plug and drain the engine coolant. Remove the radiator cap (A) to speed draining.

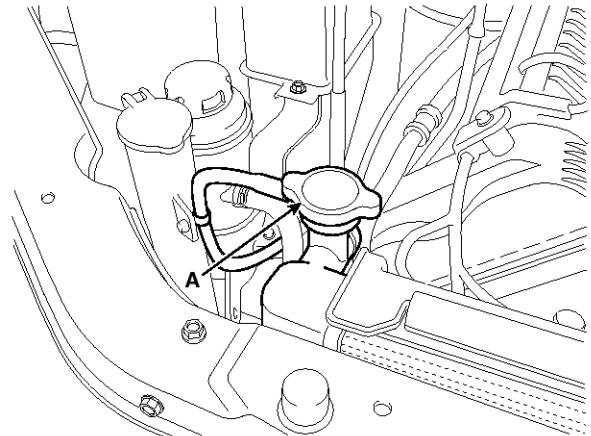

SHMM19047N

5. Disconnect the AFS connector (A) and breather hose (B) and then remove the air cleaner assembly (C).

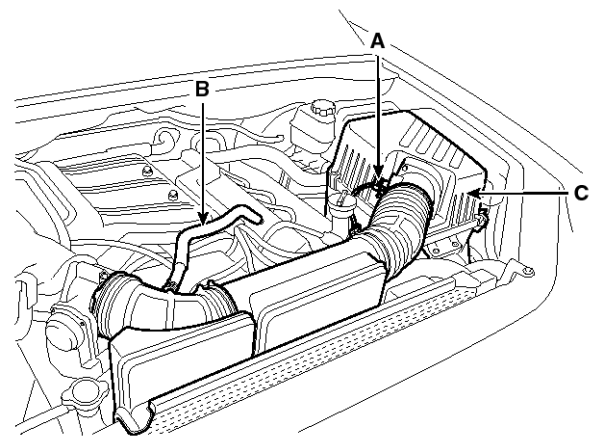

SHMEM9002L

## EM-104

## Engine Mechanical System

6. Disconnect the radiator upper hose (A) and lower hose (B).

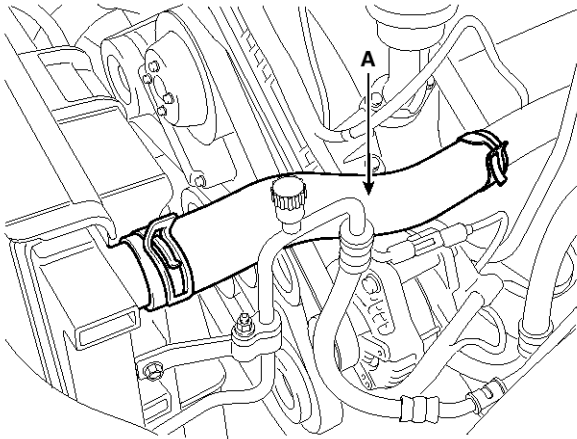

SHMEM9003L

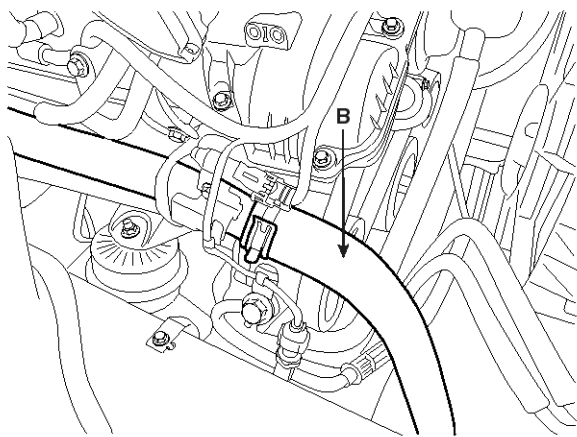

SBHEM8003D

7. Disconnect the power steering fluid cooler pipe (A) from the cooling module by loosen the bolts.

**Tightening torque :**

8.8 ~ 13.7N.m (0.9 ~ 1.4kgf.m, 6.5 ~ 10.1lb-ft)

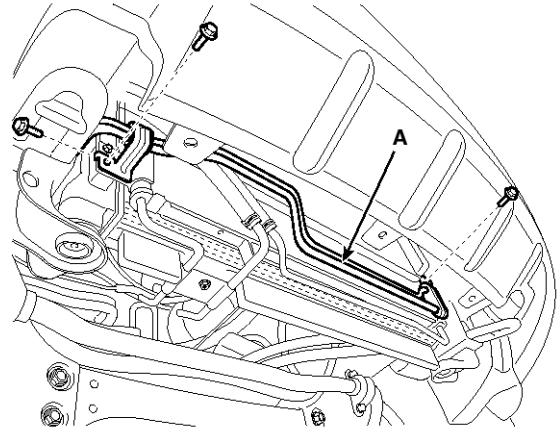

SHMEM9016L

8. Remove the radiator.

- 1) Disconnect the fan motor connector (A).
- 2) Disconnect the ATF cooler hoses (B).
- 3) Remove the cooling module mounting nuts (C).

**Tightening torque :**

18.6 ~ 27.5N.m (1.9 ~ 2.8kgf.m, 13.7 ~ 20.3lb-ft)

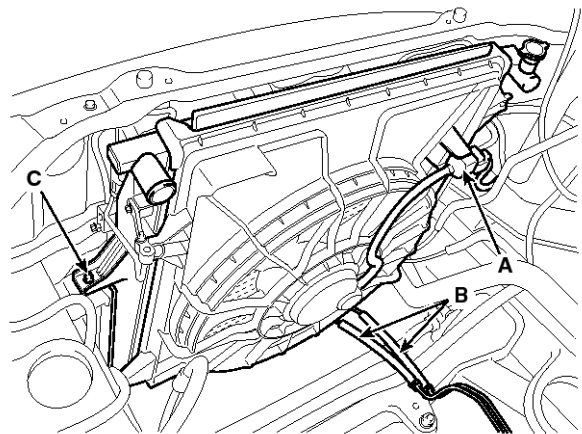

SHMEM9107L

- 4) Remove the cooling module from the vehicle.
- 5) Separate the fan assembly and radiator assembly.

## Installation

1. Installation is reverse order of removal.
2. Connect the fan motor connector.
3. Install the radiator upper hose & lower hose, and connect the ATF cooler hoses.
4. Fill the radiator with coolant and check for leaks.

# EM-106

# Engine Mechanical System

## Water pump

### Components

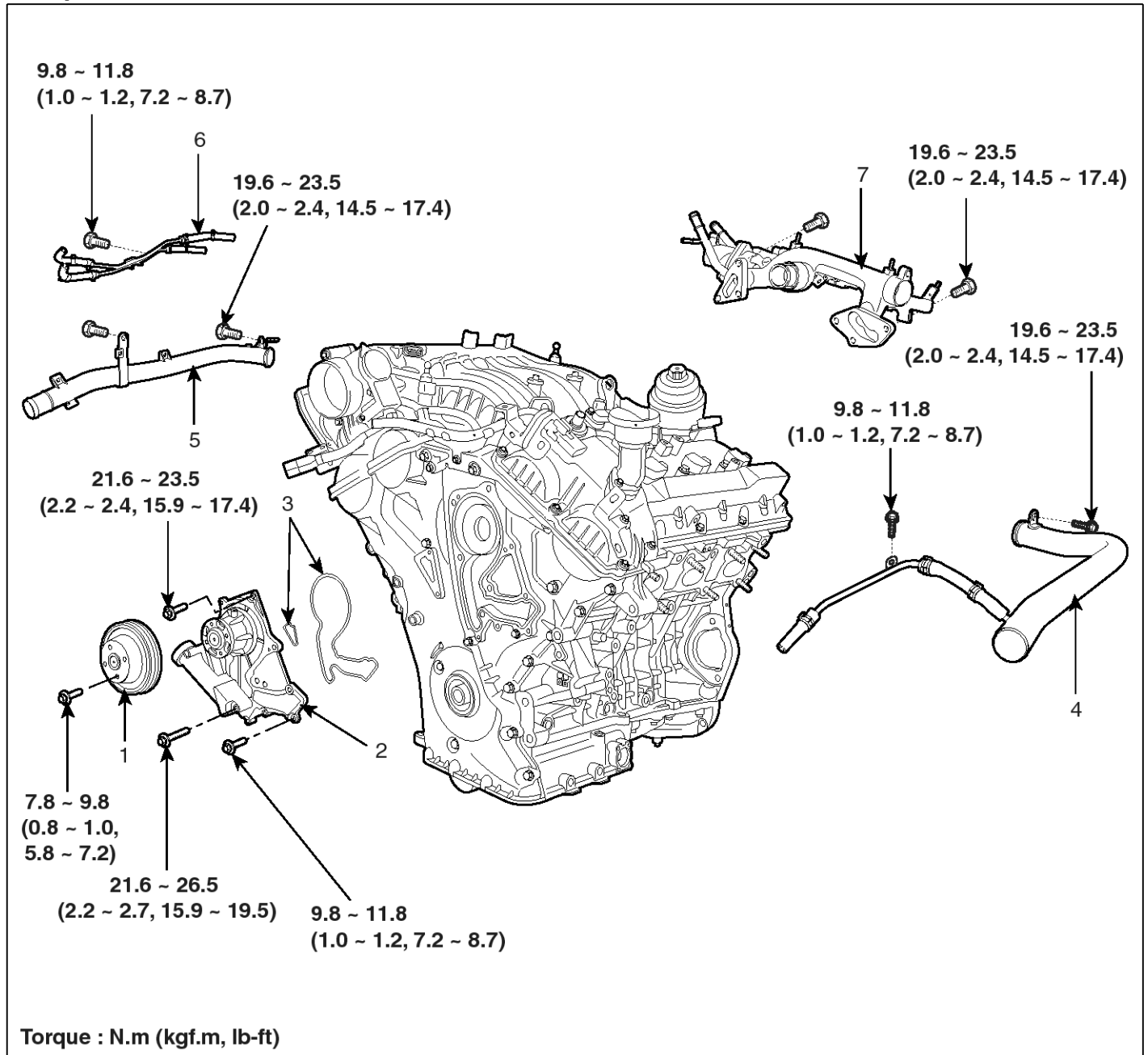

SBHEM9123L

- 1. Water pump pulley
- 2. Water pump
- 3. Water pump gasket
- 4. LH coolant pipe
- 5. RH coolant pipe
- 6. Throttle body coolant hose & pipe
- 7. Water temperature control assembly

# Cooling System

EM-107

## Removal

### Water Pump

1. Loosen the drain plug, and drain the engine coolant.

#### **CAUTION**

Never remove the radiator cap when the engine is hot. Serious scalding could be caused by hot fluid under high pressure escaping from the radiator.

2. Remove the drive belt (A).

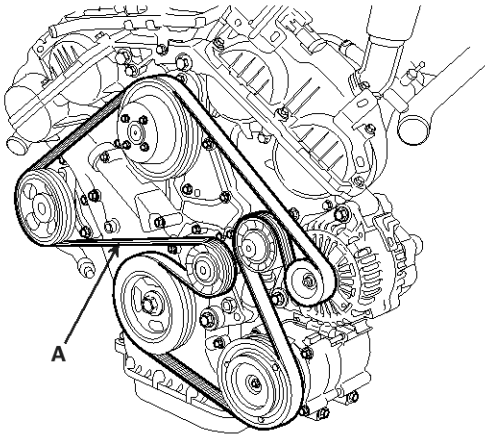

SBHEM8058D

3. Remove the water pump pulley (A).

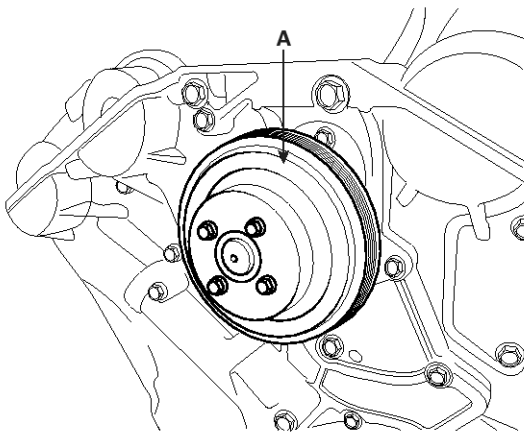

SBHEM8059D

4. Remove the water pump (A).

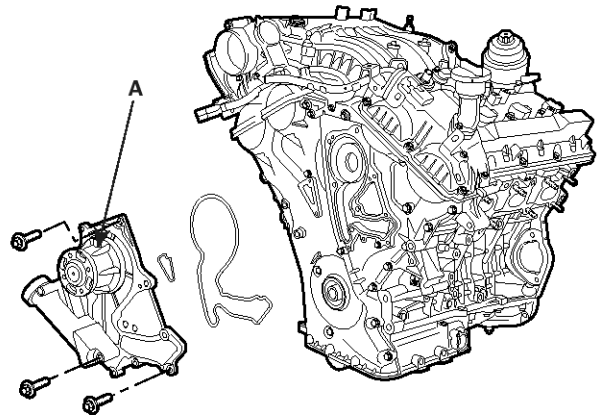

SBHEM8085D

## EM-108

## Engine Mechanical System

### Water Temperature Control Assembly

1. Disconnect the negative cable from the battery.
2. Loosen the drain plug and drain the engine coolant.
3. Remove the engine cover (A).

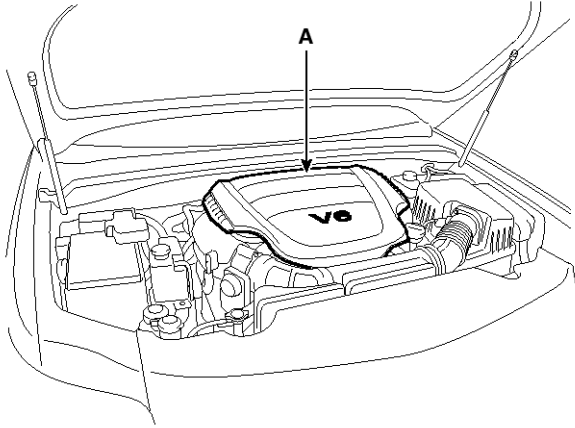

SHMEM9001L

4. Remove the radiator grill upper guard (A).

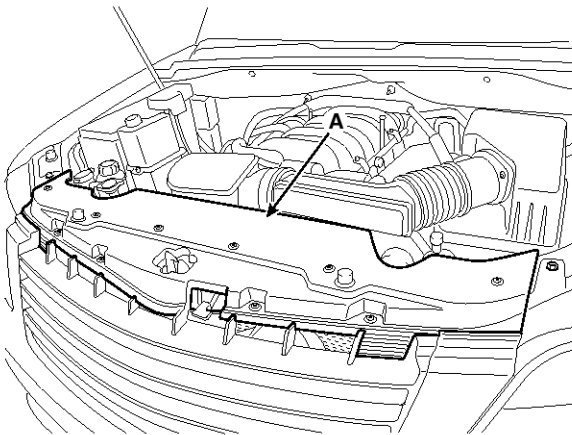

SHMM19045N

5. Disconnect the AFS connector (A) and breather hose (B) and then remove the air cleaner assembly (C).

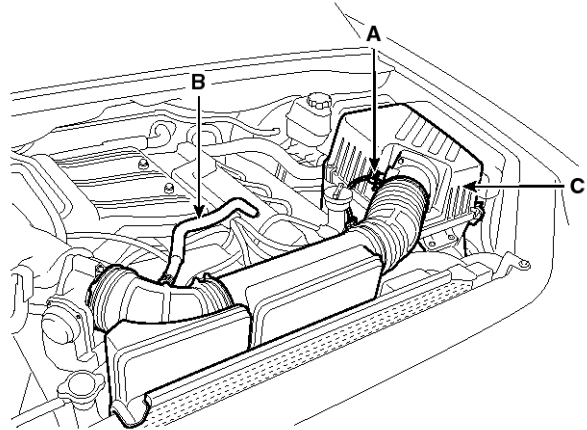

SHMEM9002L

6. Disconnect the radiator upper hose (A) and lower hose (B).

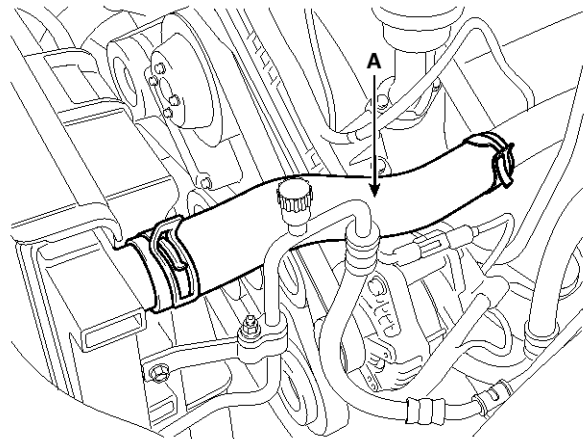

SHMEM9003L

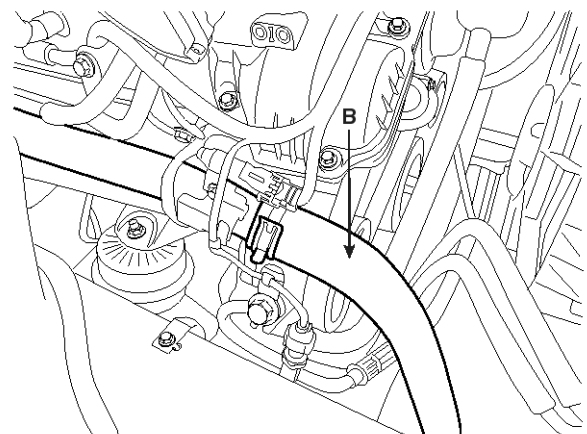

SBHEM8003D

# Cooling System

EM-109

7. Disconnect the heater hoses (A).

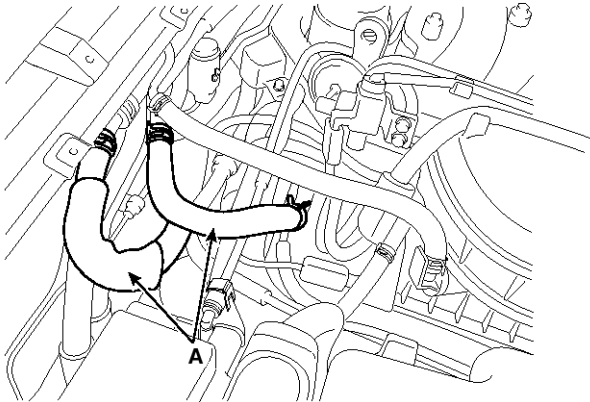

SHMEM9109L

8. Remove the throttle body coolant hose & pipe (A).

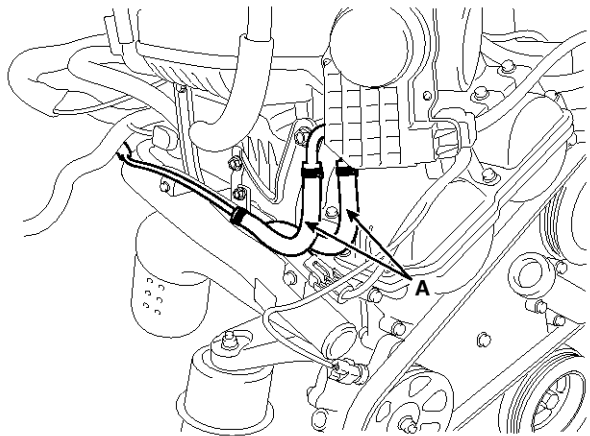

SHMEM9106L

9. Remove the RH coolant pipe (A).

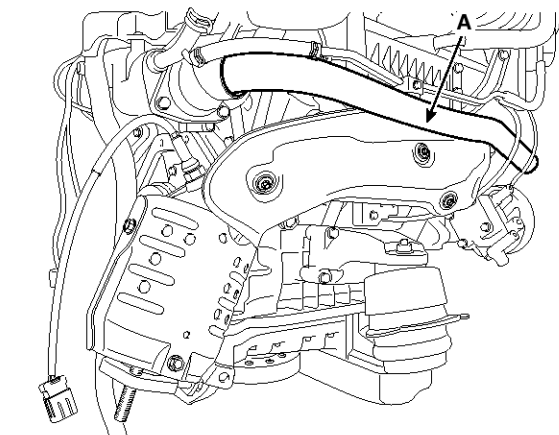

SHMEM9108L

10. Remove the LH coolant pipe and hose (A).

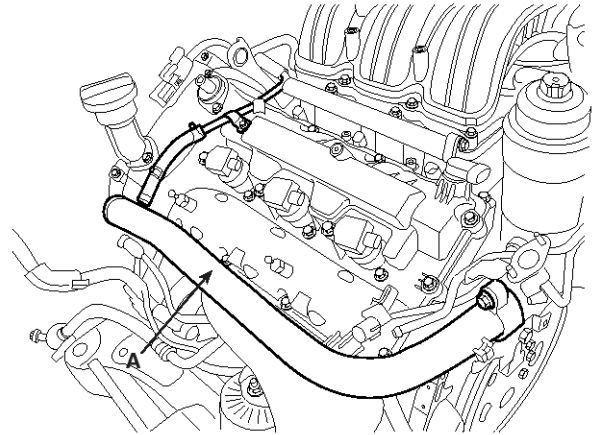

SBHEM8036D

11. Remove the mounting bolts (B,C) and then remove the water temperature control assembly (A).

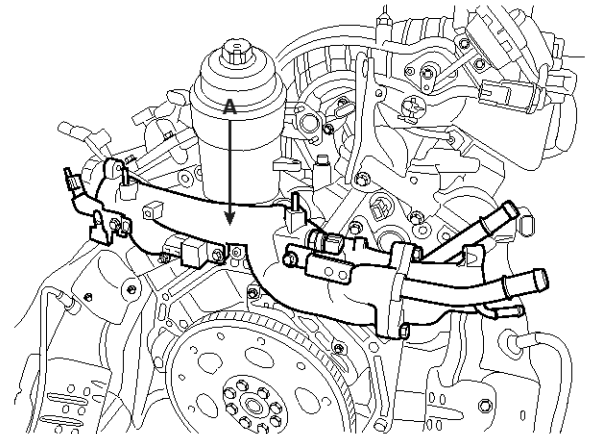

SBHEM8041D

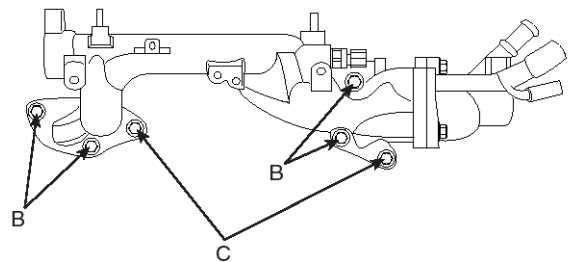

SBHEM8042D

# EM-110

# Engine Mechanical System

## Installation

### Water Pump

1. Install the water pump (A) with the new gasket (B).

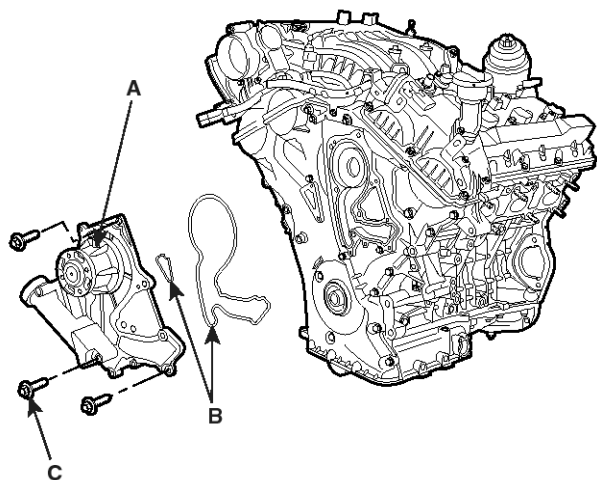

SBHEM8141D

#### NOTICE

- Clean the contact face before assembly.
- Always use a new bolt (C) and gaskets (B).

#### Tightening torque

- G(4) :  
21.56 ~ 23.52N.m (2.2 ~ 2.4kgf.m, 15.91 ~ 17.36lb-ft)
- H(1) :  
9.80 ~ 11.76N.m (1.0 ~ 1.2kgf.m, 7.23 ~ 8.68lb-ft)
- I(1) :  
9.80 ~ 11.76N.m (1.0 ~ 1.2kgf.m, 7.23 ~ 8.68lb-ft)
- J(1) :  
9.80 ~ 11.76N.m (1.0 ~ 1.2kgf.m, 7.23 ~ 8.68lb-ft)
- K(4) :  
9.80 ~ 11.76N.m (1.0 ~ 1.2kgf.m, 7.23 ~ 8.68lb-ft)
- L(1):  
21.56 ~ 26.46N.m (2.2 ~ 2.7kgf.m, 15.91 ~ 19.53lb-ft)
- New bolt

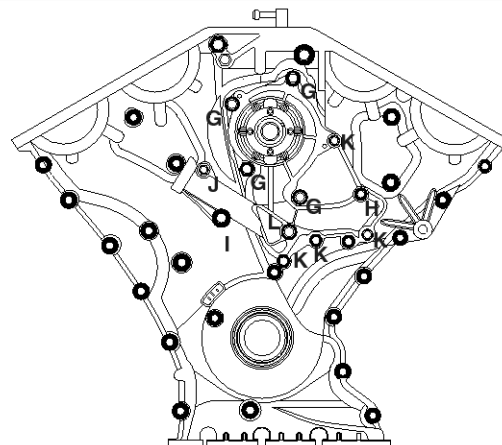

SBHEM8142D

2. Install the water pump pulley (A).

#### Tightening torque :

7.8 ~ 9.8N.m (0.8 ~ 1.0kgf.m, 5.8 ~ 7.2lb-ft)

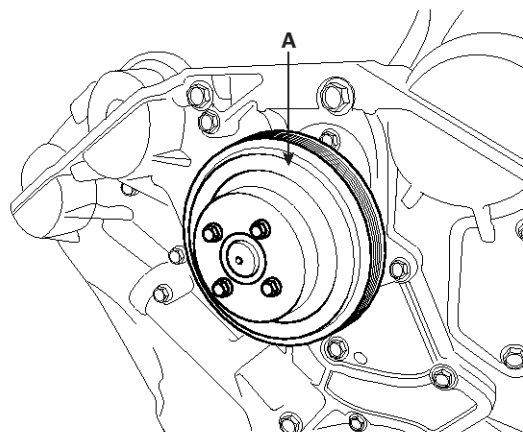

SBHEM8059D

3. Install the drive belt (A).

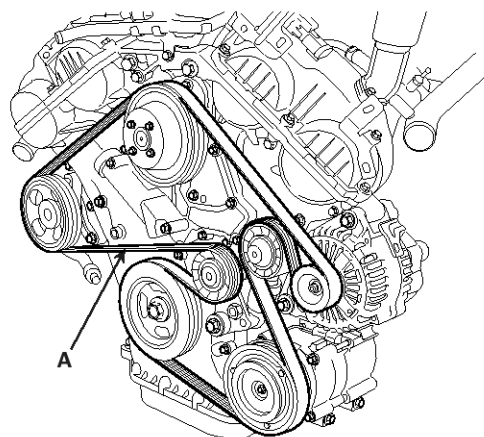

SBHEM8058D

4. Fill the radiator with coolant and check for leaks.

# Cooling System

# EM-111

## Water Temperature Control Assembly

1. Install the water temperature control assembly (A) with a new gasket.

### Tightening torque :

19.6 ~ 23.5N.m (2.0 ~ 2.4kgf.m, 14.5 ~ 17.4lb-ft)

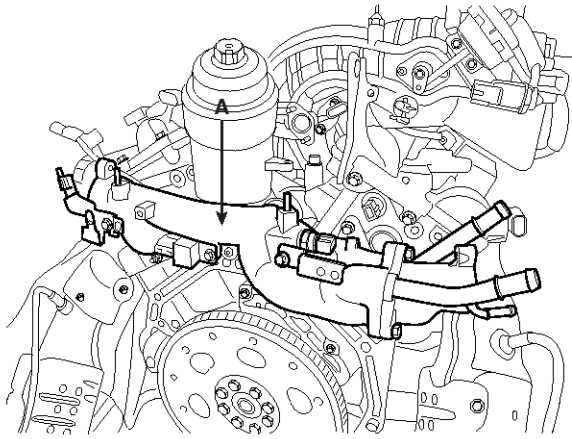

SBHEM8041D

### ⚠ CAUTION

When tightening the bolt (C), use a ground bolt.

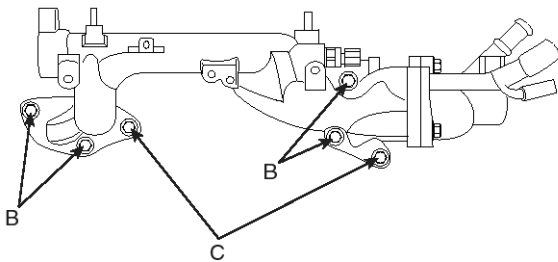

SBHEM8042D

2. Install the LH coolant pipe and hose (A).

### Tightening torque

Bolt (B): 19.6 ~ 23.5N.m (2.0 ~ 2.4kgf.m, 14.5 ~ 17.4lb-ft)

Bolt (C): 9.8 ~ 11.8N.m (1.0 ~ 1.2kgf.m, 7.2 ~ 8.7lb-ft)

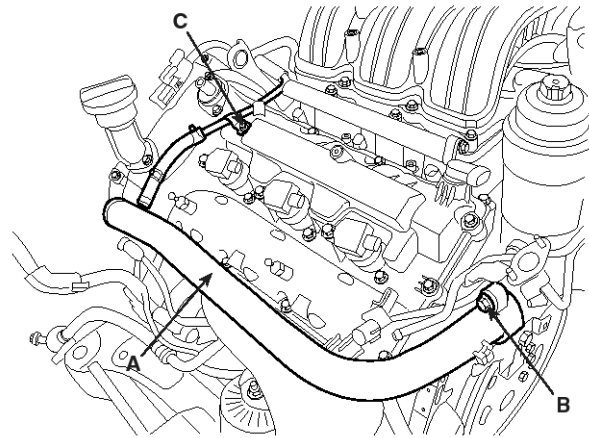

SHMEM9117L

3. Install the RH coolant pipe (A).

### Tightening torque :

19.6 ~ 23.5Nm (2.0 ~ 2.4kgf.m, 14.5 ~ 17.4lb-ft)

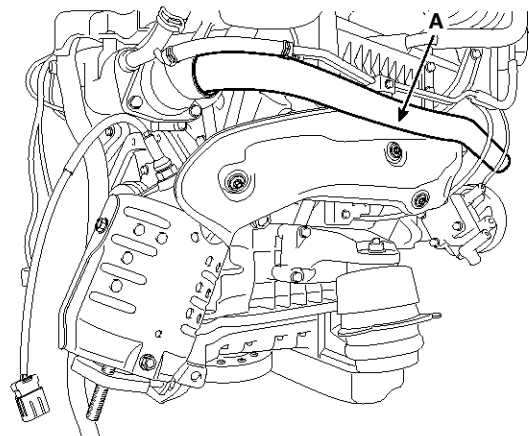

SHMEM9108L

## EM-112

## Engine Mechanical System

4. Install the throttle body coolant hose & pipe (A).

**Tightening torque :**

9.8 ~ 11.8N.m (1.0 ~ 1.2kgf.m, 7.2 ~ 8.7lb-ft)

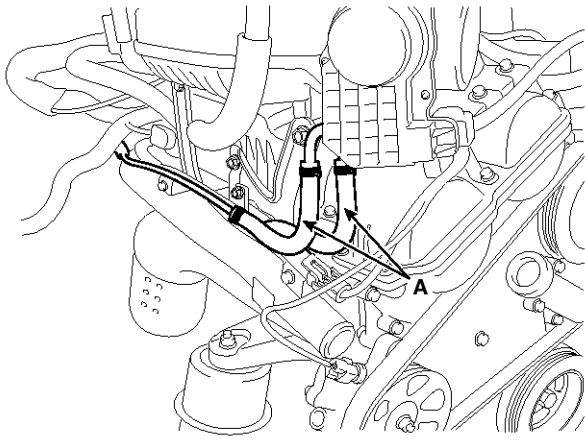

SHMEM9106L

5. Connect the heater hoses (A).

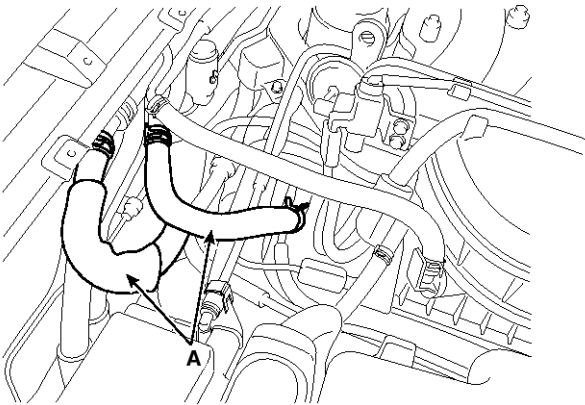

SHMEM9109L

6. Connect the radiator upper hose (A) and lower hose (B).

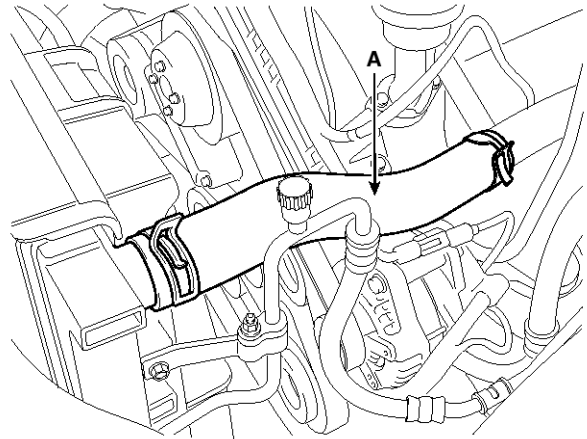

SHMEM9003L

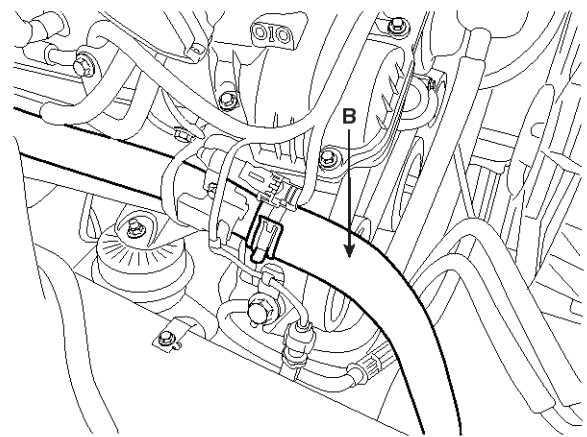

SBHEM8003D

## Cooling System

EM-113

7. Install the air cleaner assembly (C), and connect the AFS connector (A), breather hose (B).

**Tightening torque :**

7.8 ~ 9.8N.m (0.8 ~ 1.0kgf.m, 5.8 ~ 7.2lb-ft)

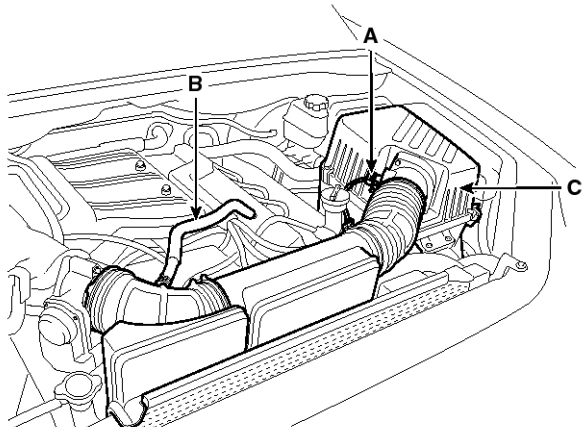

SHMEM9002L

8. Install the radiator grill upper guard (A).

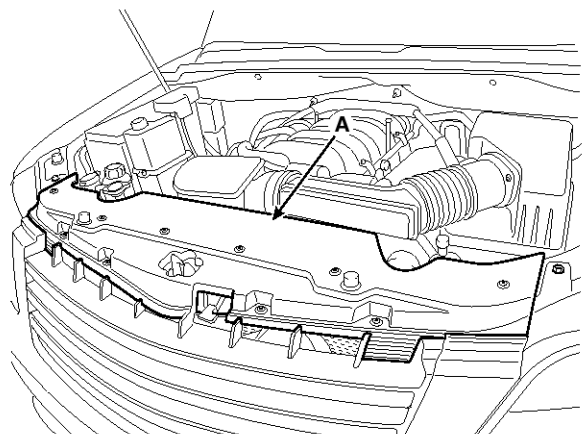

SHMM19045N

9. Install the engine cover (A).

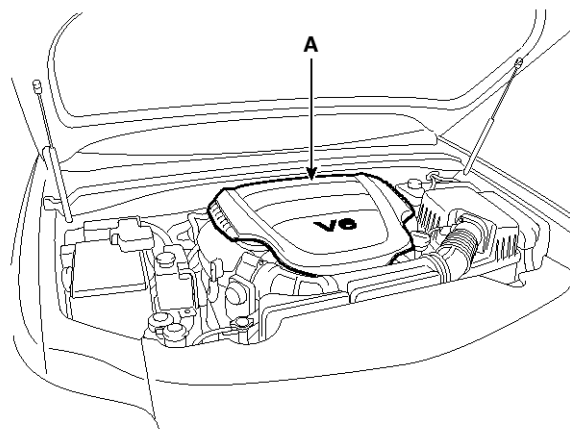

SHMEM9001L

10. Connect the battery negative cable (A).

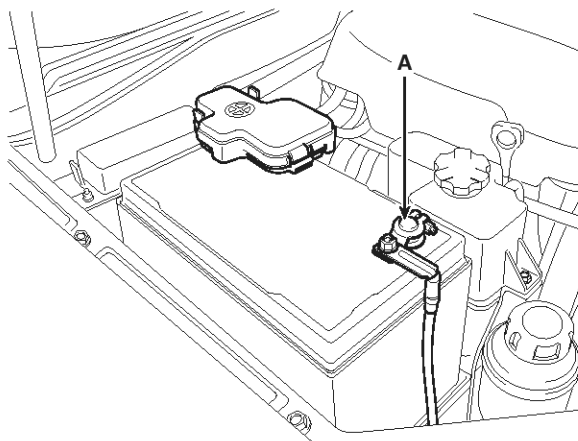

SHMM19043N

**NOTICE**

- Refill engine coolant.
- Refill radiator and reservoir tank with engine coolant.
- Bleed air from the cooling system.
  - Start engine and let it run until it warms up. (Until the radiator fan operates 3 or 4 times.)
  - Turn Off the engine. Check the level in the radiator, add coolant if needed. This will allow trapped air to be removed from the cooling system.
  - Put radiator cap on tightly, then run the engine again and check for leaks.
- Clean the battery posts and cable terminals with sandpaper assemble them, then apply grease to prevent corrosion.

# EM-114

# Engine Mechanical System

## Troubleshooting

Symptoms		Possible Causes		Remedy
Coolant leakage	<ul style="list-style-type: none"> <li>From the bleed hole of the water pump</li> </ul>	Visually check	<ul style="list-style-type: none"> <li>Check leaks after about ten-minute warming up.</li> </ul>	<ul style="list-style-type: none"> <li>If coolant still leaks, replace a water pump.</li> <li>If leakage stops, reuse the water pump (Do not replace the pump with a new one).</li> </ul>
	<ul style="list-style-type: none"> <li>From gaskets or bolts</li> </ul>		<ul style="list-style-type: none"> <li>Check the tightening of the water pump mounting bolts.</li> </ul>	<ul style="list-style-type: none"> <li>Retighten the mounting bolts.</li> </ul>
	<ul style="list-style-type: none"> <li>From outer surface of water pump</li> </ul>		<ul style="list-style-type: none"> <li>Check damage of gaskets or inflow of dust.</li> </ul>	<ul style="list-style-type: none"> <li>Replace the gasket and clean dust off.</li> </ul>
	<ul style="list-style-type: none"> <li>From outer surface of water pump</li> </ul>		<ul style="list-style-type: none"> <li>Check the material or any cracks of the water pump.</li> </ul>	<ul style="list-style-type: none"> <li>Poor material. If any crack found, replace the water pump.</li> </ul>
Noise	<ul style="list-style-type: none"> <li>From bearings</li> <li>From mechanical seals</li> <li>Impeller interference</li> </ul>	Inspection with a stethoscope	<ul style="list-style-type: none"> <li>After starting the engine, check noise with a stethoscope.</li> </ul>	<ul style="list-style-type: none"> <li>If there is no noise, reuse the water pump (do not replace it).</li> <li>If there is any noise from the water pump, remove the drive belt and recheck.</li> </ul>
		Inspection after removing a drive belt	<ul style="list-style-type: none"> <li>After removing a water pump and a drive belt, check noise again.</li> </ul>	<ul style="list-style-type: none"> <li>If there is noise, reuse the water pump. Check other drive line parts.</li> <li>If there is no noise, replace the water pump with a new one.</li> </ul>
		Inspection after removing a water pump	<ul style="list-style-type: none"> <li>After removing a water pump and a drive belt, check noise again.</li> </ul>	<ul style="list-style-type: none"> <li>If there is any interference between them, replace the water pump with a new one.</li> </ul>
Overheating	<ul style="list-style-type: none"> <li>Damaged impeller</li> <li>Loosened impeller</li> </ul>	Loosened impeller	<ul style="list-style-type: none"> <li>Corrosion of the impeller wing</li> </ul>	<ul style="list-style-type: none"> <li>Check engine coolant.</li> <li>Poor coolant quality / Maintenance check</li> </ul>
			<ul style="list-style-type: none"> <li>Impeller separation from the shaft</li> </ul>	<ul style="list-style-type: none"> <li>Replace the water pump.</li> </ul>

## Thermostat

### Removal

#### NOTICE

Do not operate the engine without the correct thermostat installed ; this may cause reduced cooling efficiency.

1. Drain engine coolant so its level is below thermostat.
2. Remove the water inlet fitting (A) and the thermostat (B).

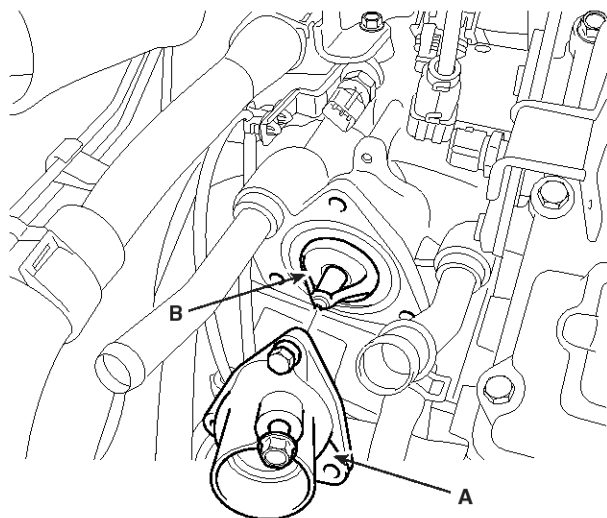

SBLM16026L

### Installation

1. Place the thermostat in thermostat housing.
  - 1) Install the thermostat with the jiggle valve upward.
  - 2) Install a new thermostat (B).

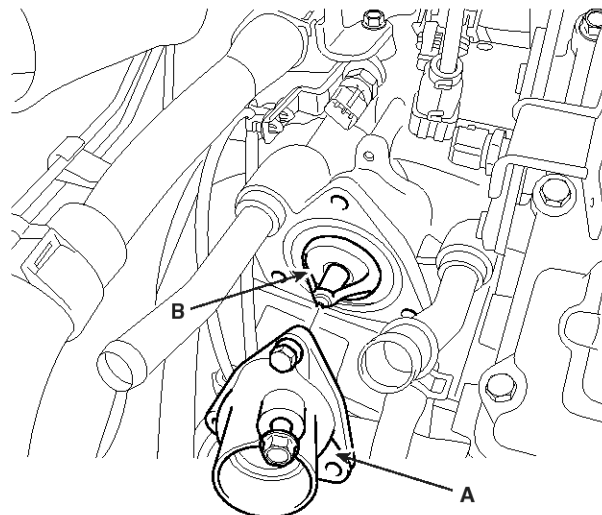

SBLM16026L

2. Install the water inlet fitting (A).

#### **Tightening torque :**

16.7 ~ 19.6N.m (1.7 ~ 2.0kgf.m, 12.3 ~ 14.5lb-ft)

3. Fill with engine coolant.
4. Start engine and check for leaks.

## EM-116

## Engine Mechanical System

### Troubleshooting

Symptoms		Possible Causes		Remedy
Coolant leakage	<ul style="list-style-type: none"> <li>From the thermostat gasket</li> </ul>	Check the mounting bolts	<ul style="list-style-type: none"> <li>Check the torque of the mounting bolts</li> </ul>	<ul style="list-style-type: none"> <li>Retighten the bolts and check leakage again.</li> </ul>
		Check the gasket for damage	<ul style="list-style-type: none"> <li>Check gasket or seal for damage</li> </ul>	<ul style="list-style-type: none"> <li>Replace gaskets and reuse the thermostat.</li> </ul>
Cooled excessively	<ul style="list-style-type: none"> <li>Low heater performance (cool air blown-out)</li> <li>Temperature gauge indicates 'LOW'</li> </ul>	Visually check after removing the radiator cap.	<ul style="list-style-type: none"> <li>Insufficient coolant or leakage.</li> </ul>	<ul style="list-style-type: none"> <li>After refilling coolant, recheck.</li> </ul>
		GDS check & Starting engine	<ul style="list-style-type: none"> <li>Check DTCs</li> <li>Check connection of the fan clutch or the fan motor.</li> <li>※ If the fan clutch is always connected, there will be a noise at idle.</li> </ul>	<ul style="list-style-type: none"> <li>Check the engine coolant sensor, wiring and connectors.</li> <li>Replace the components.</li> </ul>
		Remove the thermostat and inspect	<ul style="list-style-type: none"> <li>Check if there are dusts or chips in the thermostat valve.</li> <li>Check adherence of the thermostat.</li> </ul>	<ul style="list-style-type: none"> <li>Clean the thermostat valve and reuse the thermostat.</li> <li>Replace the thermostat, if it doesn't work properly.</li> </ul>
Heated excessively	<ul style="list-style-type: none"> <li>Engine overheated</li> <li>Temperature gauge indicates 'HI'</li> </ul>	Visually check after removing the radiator cap.	<ul style="list-style-type: none"> <li>Insufficient coolant or leakage.</li> <li>※ Be careful when removing a radiator cap of the overheated vehicle.</li> <li>Check air in cooling system.</li> </ul>	<ul style="list-style-type: none"> <li>After refilling coolant, recheck.</li> <li>Check the cylinder head gaskets for damage and the tightening torque of the mounting bolts.</li> </ul>
		GDS check & Starting engine	<ul style="list-style-type: none"> <li>Check DTCs</li> <li>Check the fan motor performance as temperature varies.</li> <li>Check if the fan clutch slips.</li> <li>Check the water pump adherence or impeller damaged.</li> </ul>	<ul style="list-style-type: none"> <li>Check the engine coolant sensor, wiring and connectors.</li> <li>Check the fan motor, the relay and the connector.</li> <li>Replace the fan clutch, if it doesn't work properly.</li> <li>Replace the water pump, if it doesn't work properly.</li> </ul>
		Immerse the thermostat in boiling water and inspection.	<ul style="list-style-type: none"> <li>After removing the thermostat, check it works properly.</li> <li>※ Check the thermostat opens at the valve opening temperature.</li> </ul>	<ul style="list-style-type: none"> <li>Replace the thermostat, if it doesn't work properly.</li> </ul>

## Lubrication System

### Oil Pump

#### Components

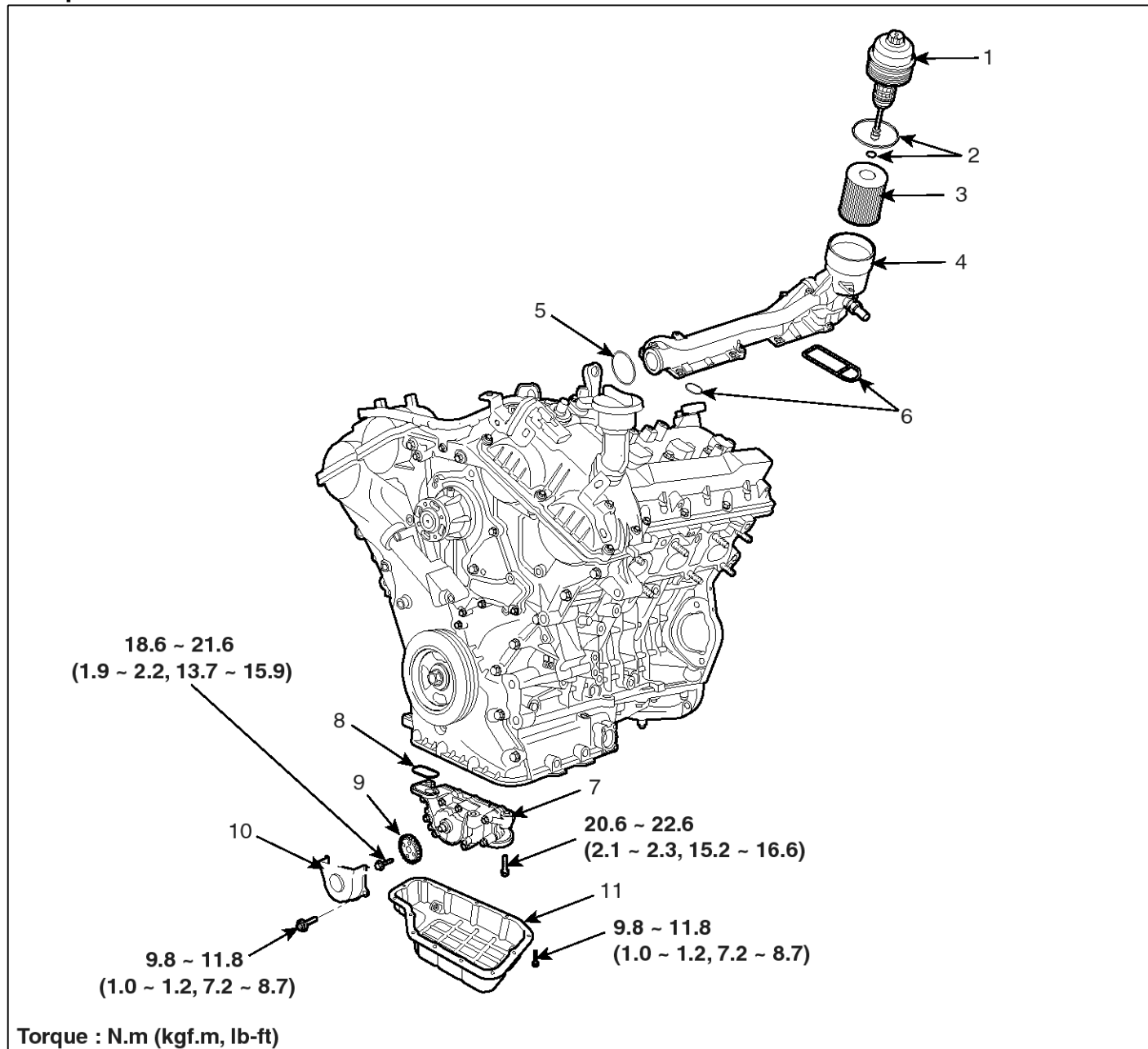

SBHEM9087L

- |                       |             |                          |
|-----------------------|-------------|--------------------------|
| 1. Oil filter cap     | 5. O-ring   | 9. Oil pump sprocket     |
| 2. O-ring             | 6. Gasket   | 10. Oil pump chain cover |
| 3. Oil filter element | 7. Oil pump | 11. Lower oil pan        |
| 4. Oil filter body    | 8. Gasket   |                          |

## EM-118

## Engine Mechanical System

### Removal

#### Oil Pump

1. Drain the engine oil.
2. Remove the lower oil pan (A).

Insert the blade of SST(09215-3C000) between the upper oil pan and lower oil pan. Cut off applied sealer and remove the lower oil pan.

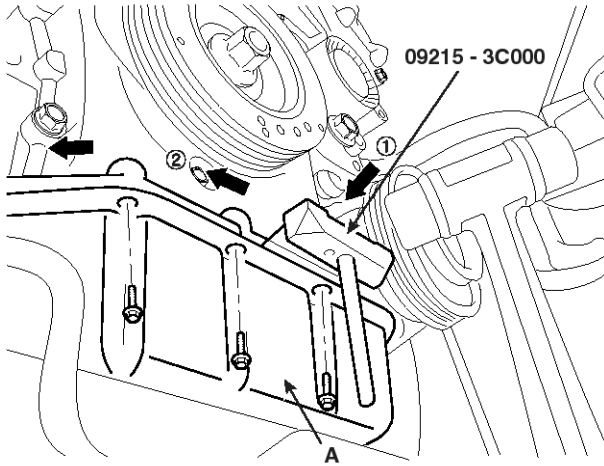

SBLM16019L

#### NOTICE

- Insert the SST between the oil pan and the ladder frame by tapping it with a plastic hammer in the direction of arrow.
- After tapping the SST with a plastic hammer along the direction of arrow around more than 2/3 edge of the oil pan, remove it from the ladder frame.
- Do not turn over the SST abruptly without tapping. It be result in damage of the SST.
- Be careful not to damage the contact surfaces of Upper oil pan and lower oil pan.

3. Remove the oil pump chain cover (A).

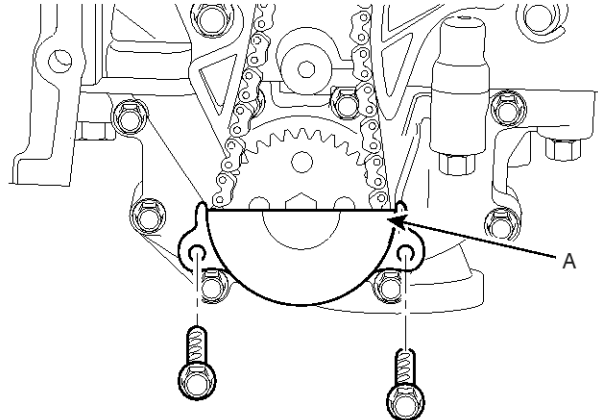

SBHEM8209D

4. Remove the oil pump chain sprocket (A).

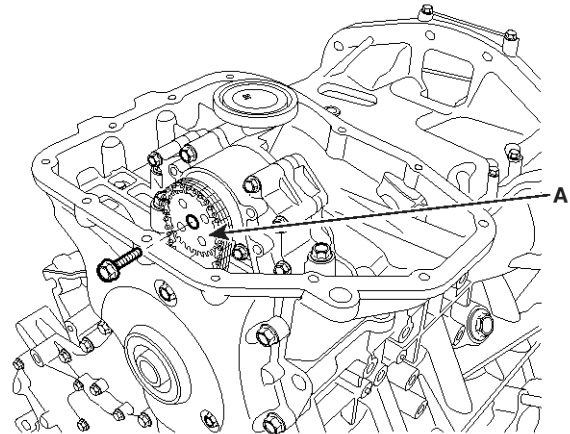

KDRF189A

5. Remove the oil pump (A).

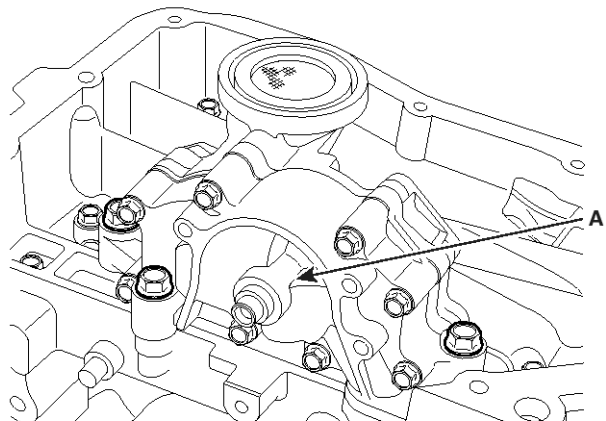

KDRF190A

# Lubrication System

EM-119

## Oil Filter Assembly

1. Remove the water temperature control assembly. (Refer to Cooling system in this group)
2. Remove the intake manifold. (Refer to Intake and exhaust system in this group)
3. Wait for 5 minutes after loosening the oil filter cap to drain well the oil in the oil filter.

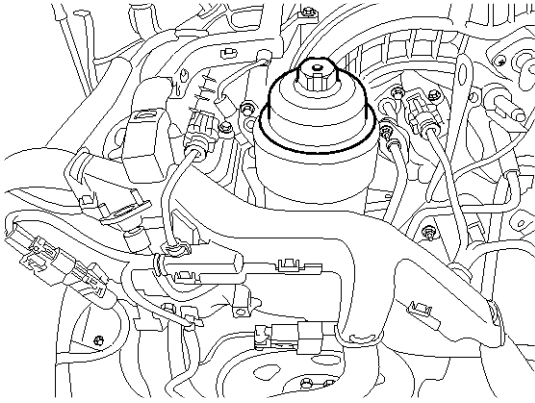

SBHEM8119D

4. Remove the oil filter body.

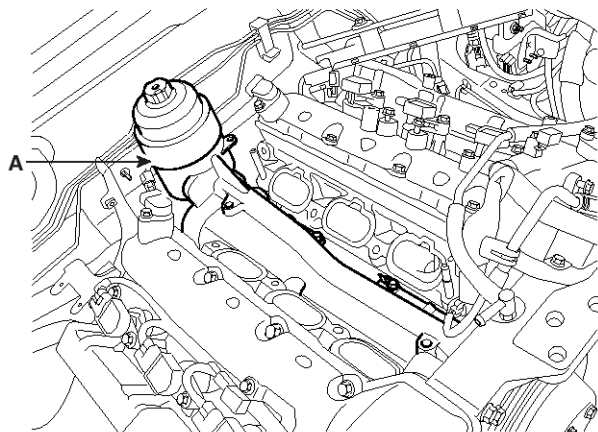

SBHEM8121D

## Installation

### Oil Pump

1. Install the oil pump (A).

#### Tightening torque :

20.6 ~ 22.6N.m (2.1 ~ 2.3kgf.m, 15.2 ~ 16.6lb-ft)

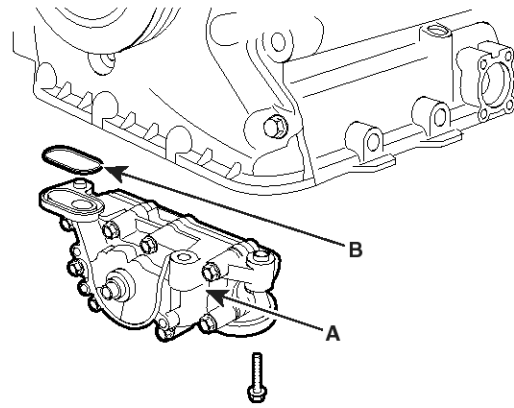

KDRF222A

#### NOTICE

Always use a new O-ring (B).

2. Install the oil pump sprocket (A) and the oil pump chain on the oil pump.

#### Tightening torque :

18.6 ~ 21.6N.m (1.9 ~ 2.2kgf.m, 13.7 ~ 15.9lb-ft)

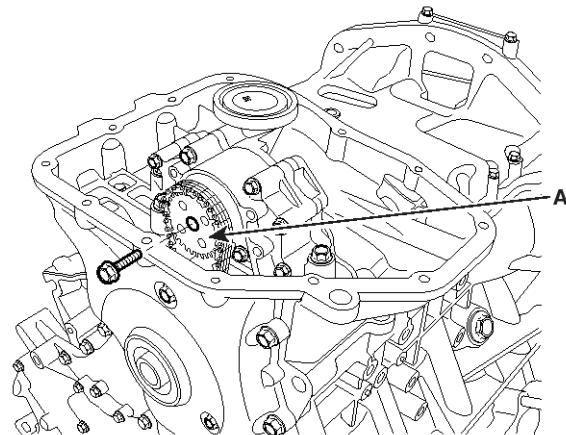

KDRF189A

## EM-120

## Engine Mechanical System

3. Install the oil pump chain cover (A).

**Tightening torque :**

9.8 ~ 11.8N.m (1.0 ~ 1.2kgf.m, 7.2 ~ 8.7lb-ft)

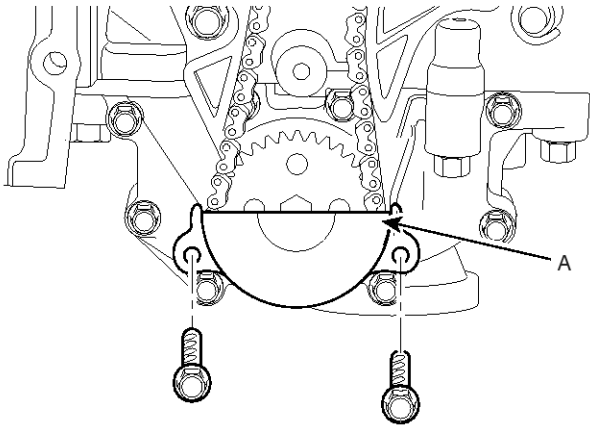

SBHEM8209D

4. Install the lower oil pan (A).

- 1) Using a gasket scraper, remove all the old packing material from the gasket surfaces.
- 2) Before assembling the oil pan, the liquid sealant TB 1217H should be applied on oil pan. The part must be assembled within 5 minutes after the sealant was applied.

**Bead width : 2.5mm(0.1in.)**

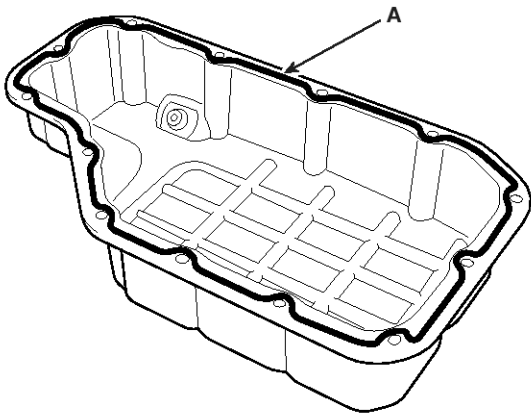

SBLM16020L

**CAUTION**

- Clean the sealing face before assembling two parts.
- Remove harmful foreign matters on the sealing face before applying sealant.
- When applying sealant gasket, sealant must not be protruded into the inside of oil pan.
- To prevent leakage of oil, apply sealant gasket to the inner threads of the bolt holes.

3) Install the oil pan (A).

Uniformly tighten the bolts in several passes.

**Tightening torque :**

9.8 ~ 11.8N.m (1.0 ~ 1.2kgf.m, 7.2 ~ 8.7lb-ft)

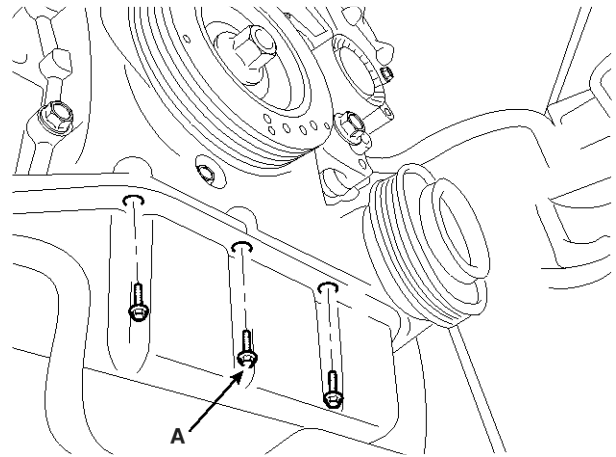

SBLM16102L

5. After assembly, wait at least 30 minutes before filling the engine with oil.

# Lubrication System

# EM-121

## Oil Filter Assembly

1. Install the oil filter body.

### Tightening torque :

9.8 ~ 11.8N.m (1.0 ~ 1.2kgf.m, 7.2 ~ 8.7lb-ft)

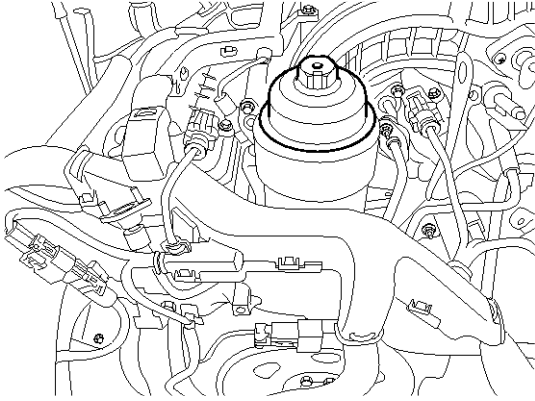

SBHEM8119D

### ⚠ CAUTION

- All rubber gaskets must not be damaged by assembling parts.
- Always use a new O-ring (C) and oil seal (B).

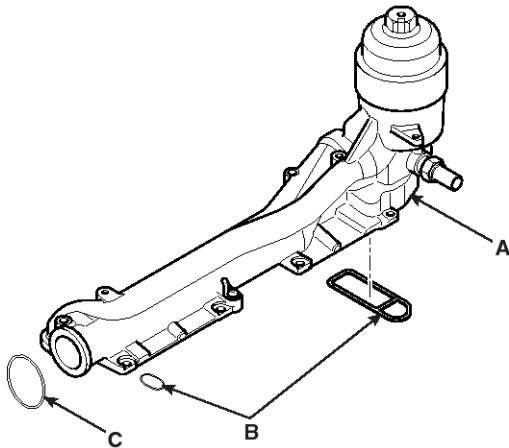

SBHEM8122D

2. Install the intake manifold. (Refer to Intake and exhaust system in this group)
3. Install the water temperature control assembly. (Refer to Cooling system in this group)

**Oil Pressure Switch**

**Inspection**

1. Check the continuity between the terminal and the body with an ohmmeter.

If there is no continuity, replace the oil pressure switch.

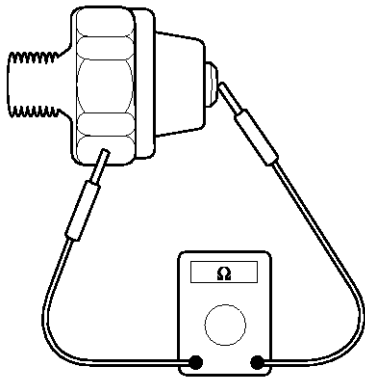

ECKD001W

2. Check the continuity between the terminal and the body when the fine wire is pushed. If there is continuity even when the fine wire is pushed, replace the switch.

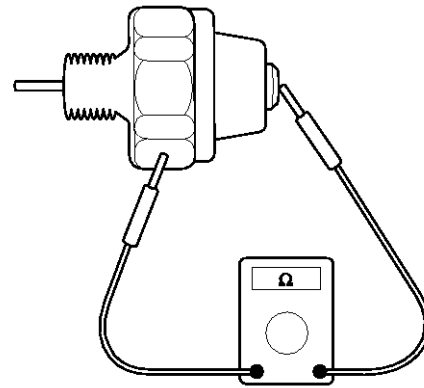

ECKD001Y

## Engine Oil

### Inspection

1. Check the engine oil quality. Check the oil deterioration, entry of water, discoloring or thinning. If the quality is visibly poor, replace the oil.
2. Check the engine oil level.

After warming up the engine and then 5 minutes after the engine stop, oil level should be between the "L" and "F" marks in the dipstick.

If low, check for leakage and add oil up to the "F" mark.

#### NOTICE

*Do not fill with engine oil above the "F" mark.*

### Selection Of Engine Oil

Recommended API classification :Above SJ or SL

Recommended SAE classification : 5W-20

#### NOTICE

*For best performance and maximum protection of all types of operation, select only those lubricants which :*

1. *Satisfy the requirement of the API or ACEA classification.*
2. *Have proper SAE grade number for expected ambient temperature range.*
3. *Lubricants that do not have both an SAE grade number and API service classification on the container should not be used.*

## EM-124

## Engine Mechanical System

### Replacement

#### ⚠CAUTION

- Prolonged and repeated contact with mineral oil will result in the removal of natural fats from the skin, leading to dryness, irritation and dermatitis. In addition, used engine oil contains potentially harmful contaminants which may cause skin cancer.
- Exercise caution in order to minimize the length and frequency of contact of your skin to used oil. Wear protective clothing and gloves. Wash your skin thoroughly with soap and water, or use water-less hand cleaner, to remove any used engine oil. Do not use gasoline, thinners, or solvents.
- In order to preserve the environment, used oil and used oil filter must be disposed of only at designated disposal sites.

1. Park the car on level ground.  
Start the engine and let it warm up.
2. Turn the engine off and open the hood.  
Remove the engine cover.
3. Wait for 5 minutes after loosening the oil filter cap to drain well the oil in the oil filter.

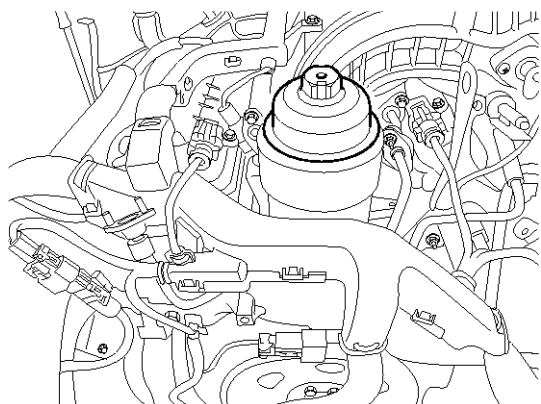

SBHEM8119D

4. Drain engine oil.
  - 1) Remove the oil filler cap.
  - 2) After lifting the car, remove the oil drain plug and drain oil into a container.
5. Replace the oil filter.
  - 1) Disconnect the oil filter cap from the oil filter body.
  - 2) Remove the oil filter element.
  - 3) Check and clean the oil filter installation surface.
  - 4) Check the part number of a new oil filter is same as old one.
  - 5) Install a new oil filter element (A) and two new O-rings (B).

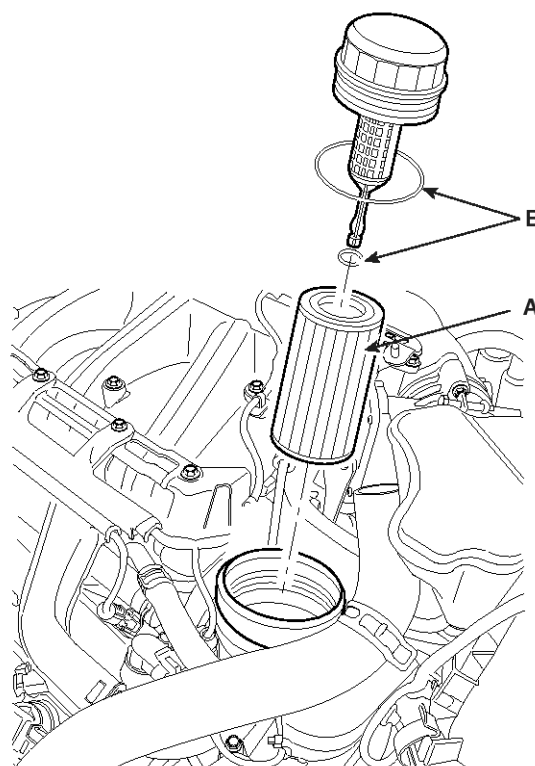

SENM17205L

- 6) Apply clean engine oil to the new O-rings.  
Lightly screw the oil filter cap into place, and tighten it until the O-ring contacts the seat.
- 7) Finally tighten it again by specified tightening torque.

#### Tightening torque :

24.5N.m (2.5kgf.m, 18.1lb-ft)

# Lubrication System

EM-125

6. Fill new engine oil.

- 1) Install the oil drain plug with a new gasket.

---

### Tightening torque :

34.3 ~ 44.1N.m (3.5 ~ 4.5kgf.m, 25.3 ~ 32.5lb-ft)

- 2) Fill with new engine oil, after removing the engine oil level gauge.

---

### Engine Oil quantity

Total : 6.0 L (6.34 US qt, 5.27 Imp qt)

Oil pan : 5.5 L (5.81 US qt, 4.83 Imp qt)

Drain and refill including oil filter :

5.2 L (4.49 US qt, 4.57 Imp qt)

---

### CAUTION

- Fill a half oil of the total amount first and do the rest again after about one minute later.
- Do not fill oil over the 'F' line, checking the level with the oil level gauge.

- 3) Install the oil filler cap and oil level gauge.

7. Start the engine and check to be sure no oil is leaking from the drain plug or oil filter.

8. Recheck the engine oil level.

# EM-126

# Engine Mechanical System

## Intake And Exhaust System

### Intake Manifold

#### Components

<NOTE>

The delivery pipe(2) may be disassembled from the intake system in removal or installation.

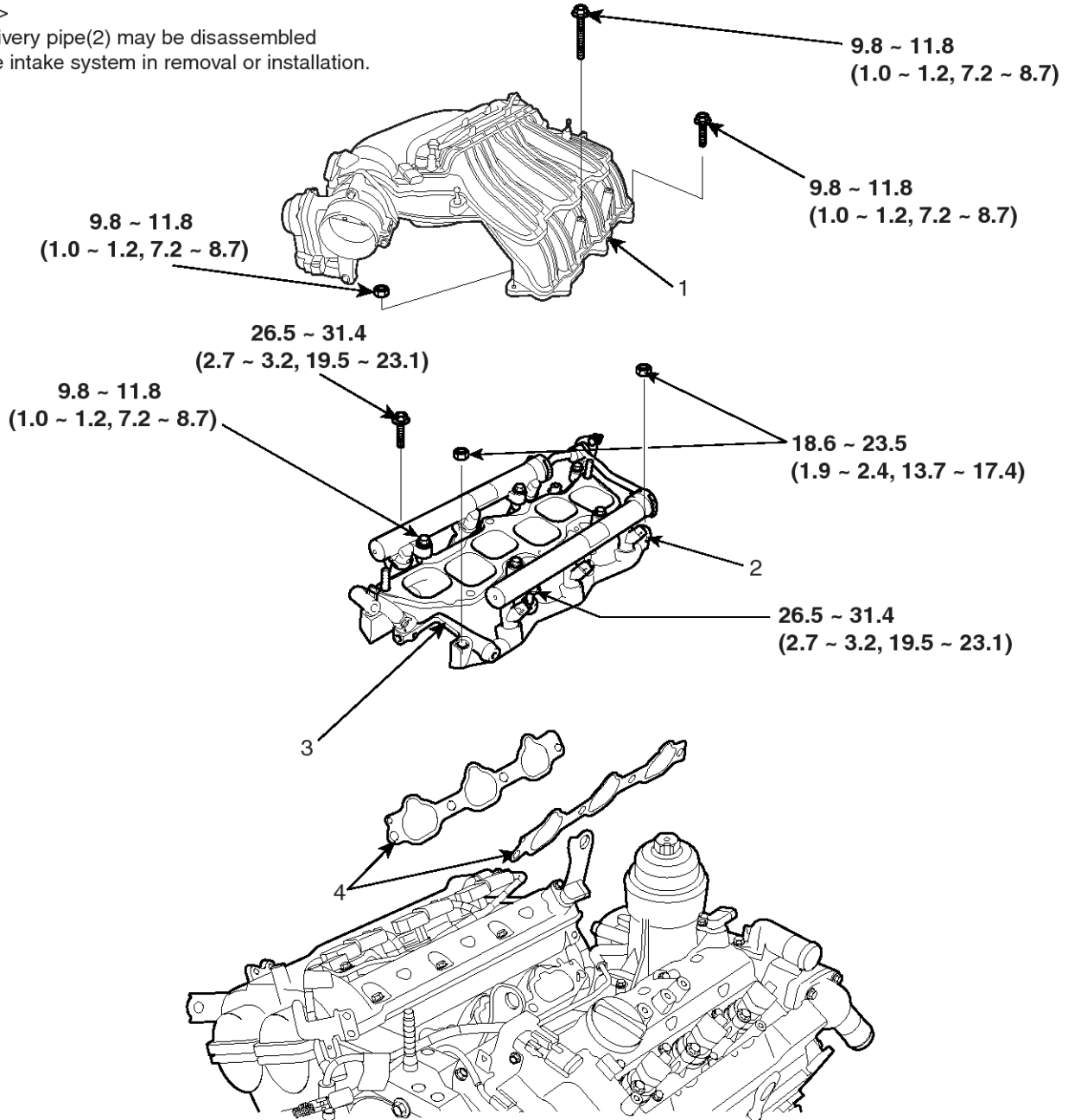

Torque : N.m (kgf.m, lb-ft)

SHMEM9103L

- 1. Surge tank
- 2. Delivery pipe

- 3. Intake manifold
- 4. Intake manifold gasket

# Intake And Exhaust System

EM-127

## Removal

### ⚠ CAUTION

- To avoid damage, unplug the wiring connectors carefully while holding the connector portion.

### 📌 NOTICE

- Mark all wiring and hoses to avoid misconnection.
1. Disconnect the negative cable (A) from the battery.

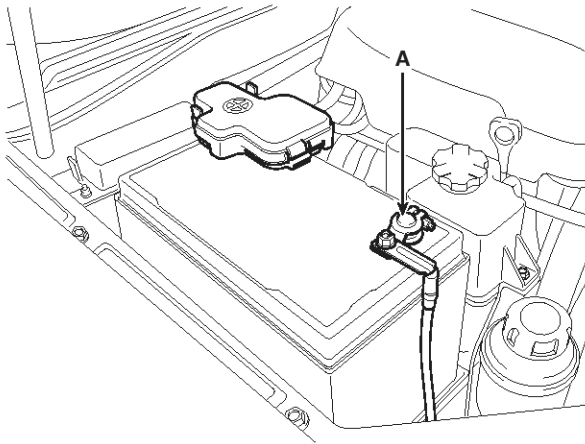

SHMM19043N

2. Loosen the drain plug and drain the engine coolant. Remove the radiator cap (A) to speed draining.

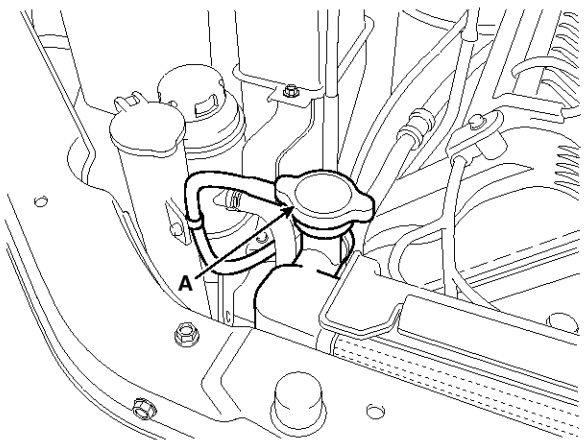

SHMM19047N

3. Remove the engine cover (A).

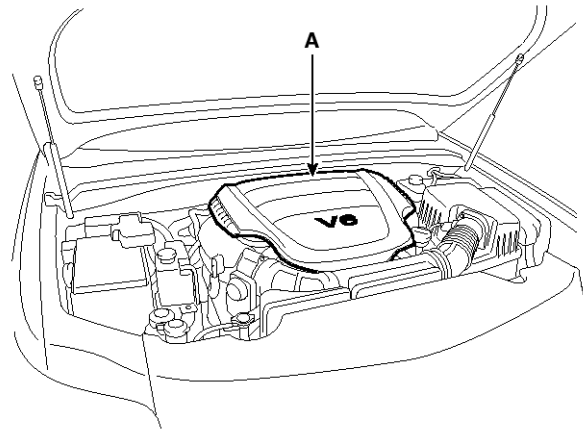

SHMEM9001L

4. Remove the radiator grill upper guard (A).

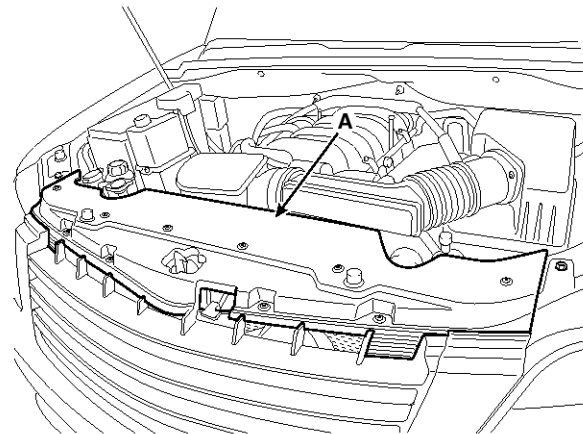

SHMM19045N

5. Disconnect the AFS connector (A) and breather hose (B) and then remove the air cleaner assembly (C).

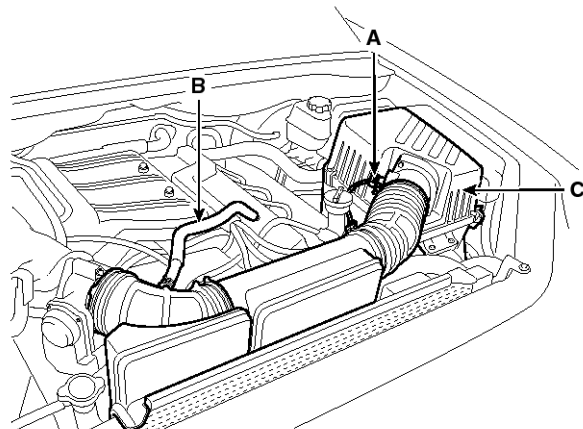

SHMEM9002L

## EM-128

## Engine Mechanical System

6. Disconnect the heater hoses (A), the fuel hose (B), the purge control solenoid valve (PCSV) hose (C) and the brake booster vacuum hose (D).

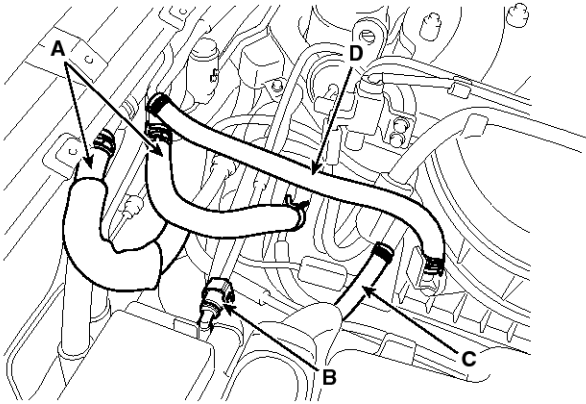

SHMEM9004L

7. Remove the fuel pipe (A).

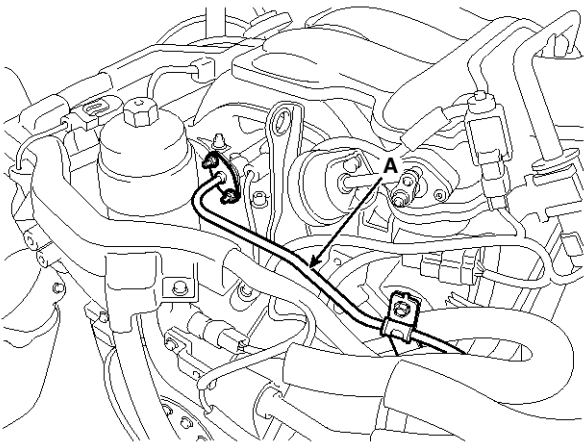

SHMEM9021L

8. Disconnect the engine wiring connectors.

- 1) Disconnect the power steering oil pressure switch connector (A) and RH knock sensor connector (B).

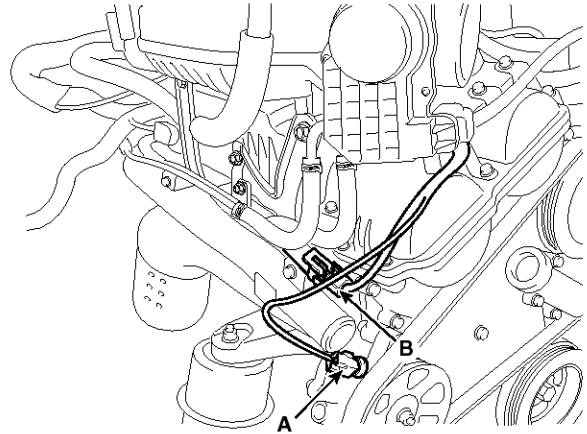

SHMEM9006L

- 2) Disconnect the MAP sensor connector (A), ETC connector (B), RH exhaust OCV connector (C), RH injector connector (D) and RH ignition coil connector (E).

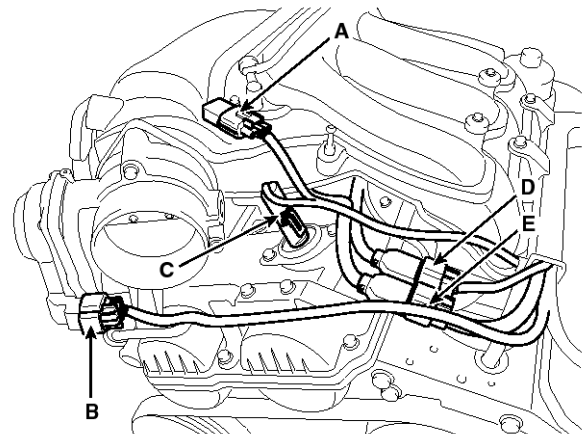

SHMEM9007L

# Intake And Exhaust System

# EM-129

- 3) Disconnect the LH knock sensor connector (A), LH/RH intake OCV connector (B) and LH exhaust OCV connector (C).

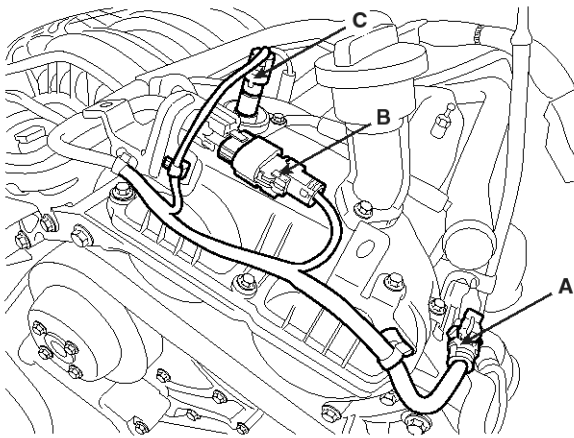

SBHEM8026D

- 4) Disconnect the LH injector connector (A) and LH ignition coil connector (B).

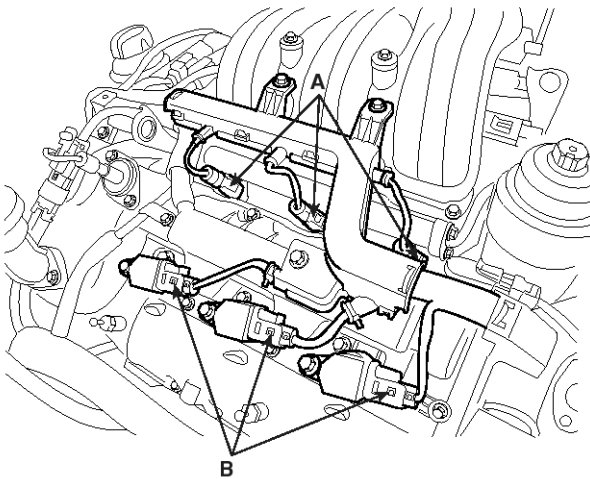

SBHEM8027D

- 5) Disconnect the oil pressure switch connector (A), LH exhaust camshaft CMP sensor connector (B) and LH oxygen sensor connector (C).

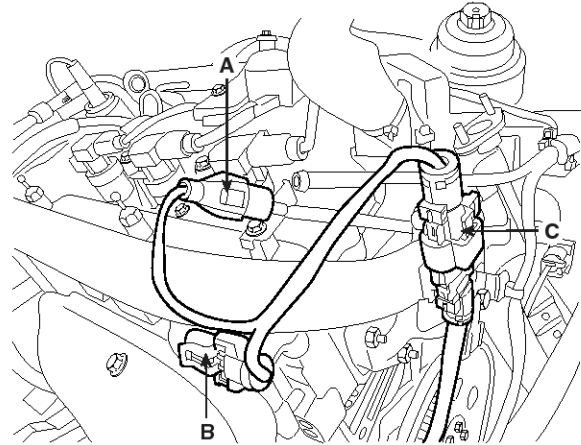

SBHEM8029D

- 6) Disconnect the LH intake camshaft CMP sensor connector (A), RH intake camshaft CMP sensor connector (B) and condenser connector (C).

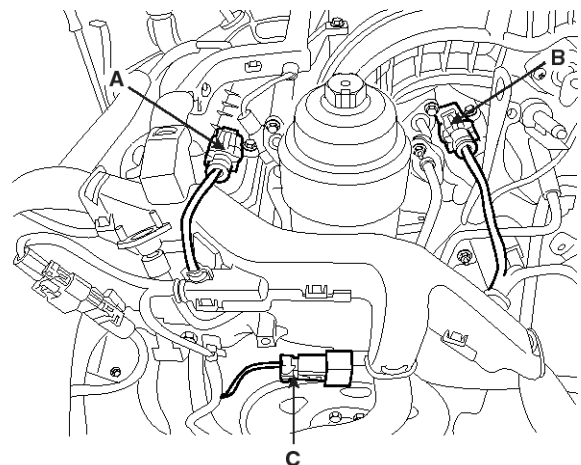

SBHEM8030D

## EM-130

## Engine Mechanical System

- 7) Disconnect the VIS solenoid valve connector (A), PCSV connector (B), RH oxygen sensor connector (C) and the RH exhaust camshaft CMP sensor connector (D).

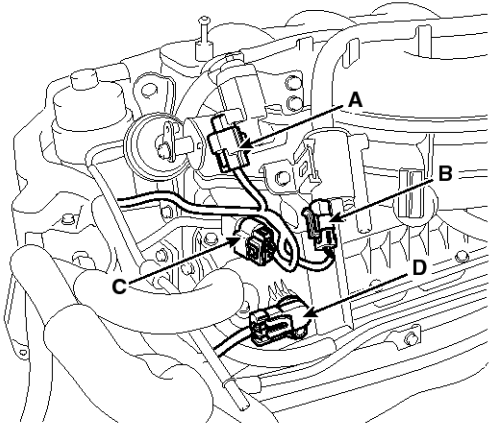

SHMEM9008L

- 8) Disconnect the water temperature sensor connector (A) and oil temperature sensor connector (B).

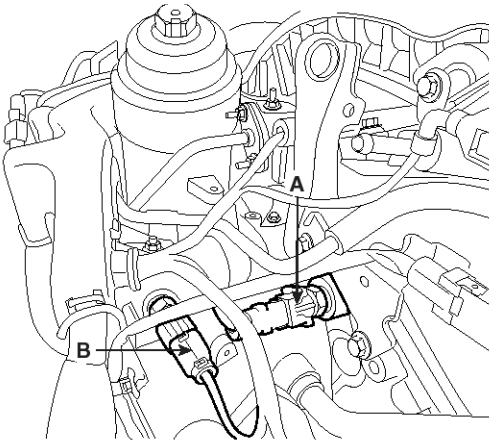

SBHEM8032D

9. Disconnect the throttle body coolant hoses (A), breather hose (B) and loosen the surge tank stay bolts (C).

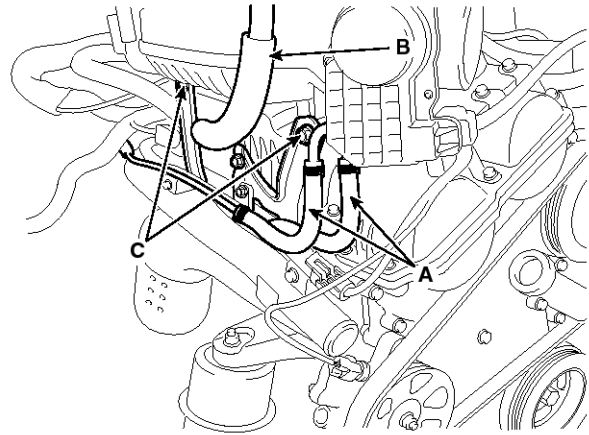

SHMEM9101L

10. Remove the surge tank (A).

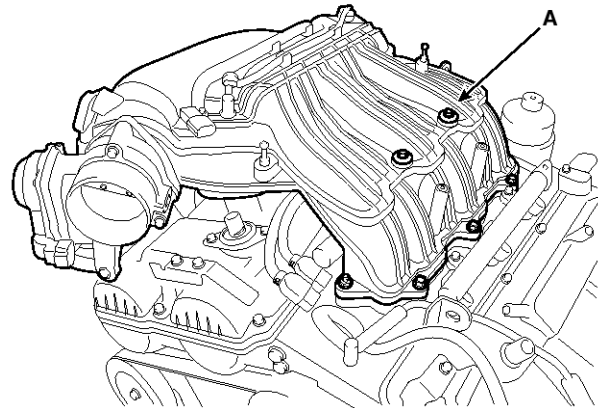

SHMEM9009L

11. Disconnect the RH ignition coil connector (A).

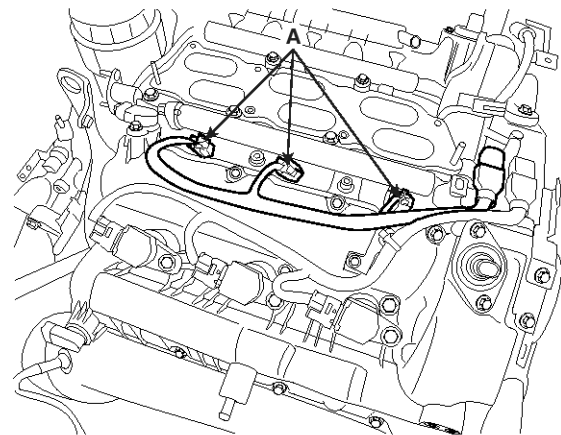

SBHEM8146D

# Intake And Exhaust System

EM-131

12. Disconnect the water vent hose (A) and then remove the intake the manifold (B).

**CAUTION**

- Be sure to drain the engine coolant before removing the intake manifold.
- If any coolant drained from the cylinder head vent hole has entered the intake port ; this can potentially lead to engine trouble.

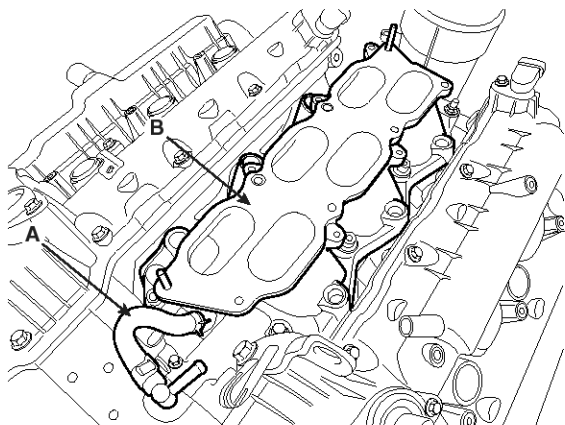

SBHEM8148D

## Installation

1. Install the intake the manifold (B) with a new gasket, and connect the water vent hose (A).

**CAUTION**

- Be sure to drain the engine coolant before removing the intake manifold.
- If any coolant drained from the cylinder head vent hole has entered the intake port ; this can potentially lead to engine trouble.

## Tightening torque

Step 1: 3.9 ~ 5.9N.m (0.4 ~ 0.6kgf.m, 2.9 ~ 4.3lb-ft)

Step 2:

Nut- 18.62 ~ 23.52N.m (1.9~2.4kgf.m, 13.74~17.36lb-ft)

Bolt -26.5 ~ 31.4N.m (2.7~3.2kgf.m, 19.5~23.1lb-ft)

Step 3: Repeat 2nd step twice or more.

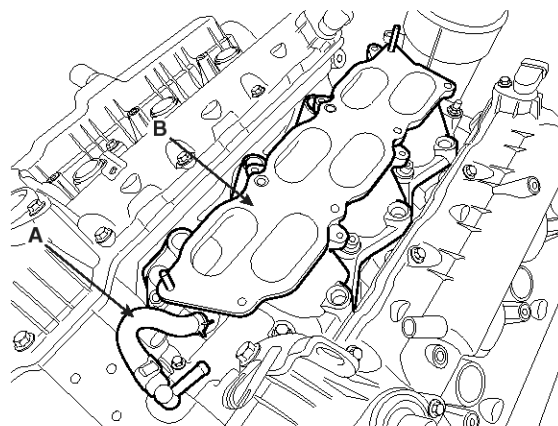

SBHEM8148D

a - h : 1st step order

1 ~ 8 : 2nd step order

# EM-132

# Engine Mechanical System

### NOTICE

Confirm the manifold gasket identification mark (LH, RH) and be careful of the installation direction.

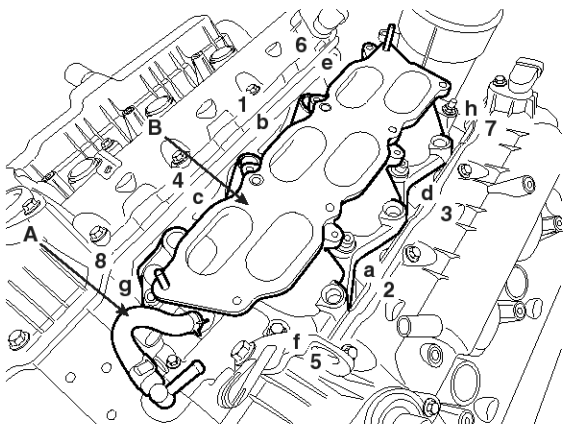

SBHEM8045D

2. Connect the RH ignition coil connector (A).

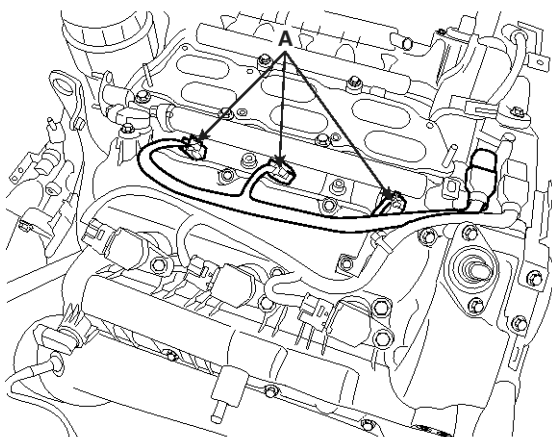

SBHEM8146D

3. Install the surge tank (A).

### Tightening torque :

9.8 ~ 11.8N.m (1.0 ~ 1.2kgf.m, 7.2 ~ 8.7lb-ft)

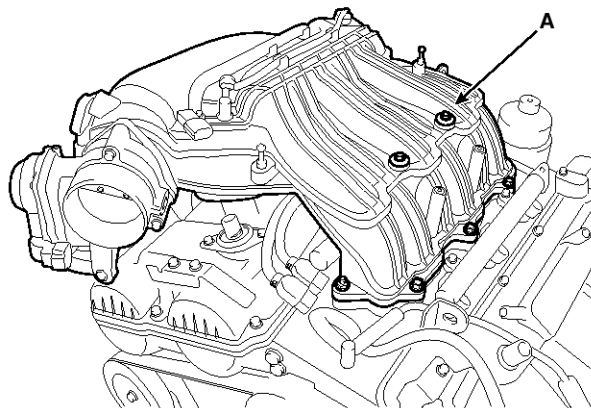

SHMEM9009L

4. Connect the throttle body coolant hoses (A), breather hose (B) and tighten the surge tank stay bolts (C).

### Tightening torque :

27.5 ~ 31.4N.m (2.8 ~ 3.2kgf.m, 20.3 ~ 23.1lb-ft)

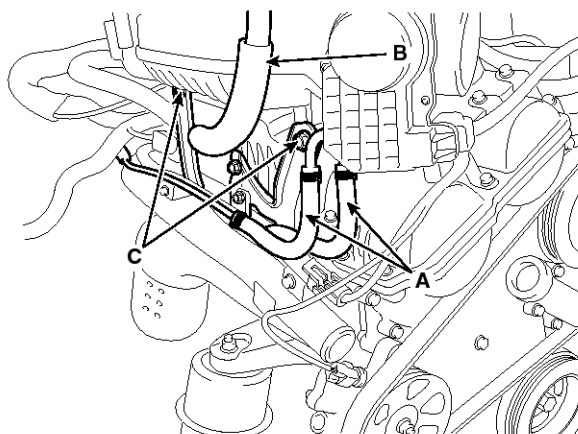

SHMEM9101L

# Intake And Exhaust System

# EM-133

5. Connect the engine wiring connectors.

- 1) Connect the water temperature sensor connector (A) and oil temperature sensor connector (B).

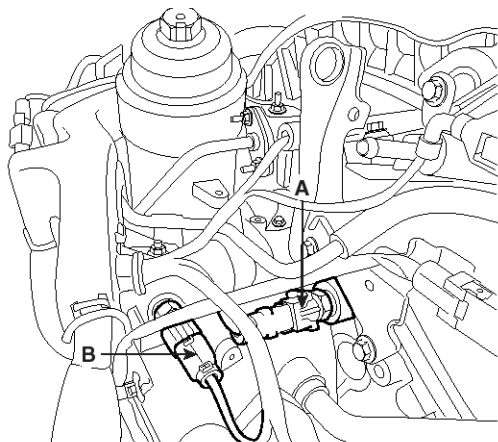

SBHEM8032D

- 2) Connect the VIS solenoid valve connector (A), PCSV connector (B), RH oxygen sensor connector (C) and the RH exhaust camshaft CMP sensor connector (D).

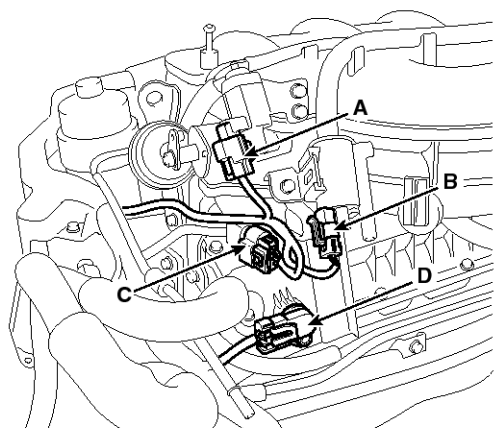

SHMEM9008L

- 3) Connect the LH intake camshaft CMP sensor connector (A), RH intake camshaft CMP sensor connector (B) and condenser connector (C).

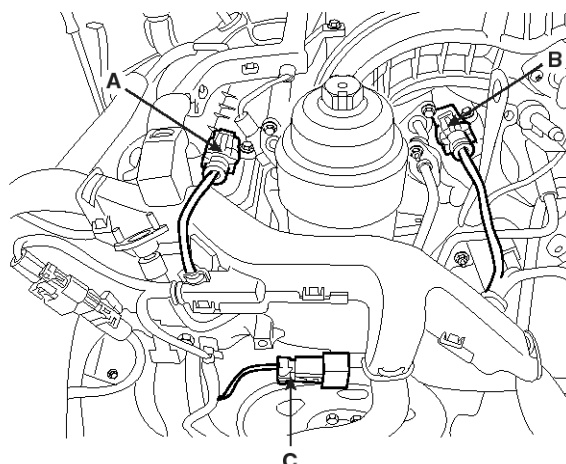

SBHEM8030D

- 4) Connect the oil pressure switch connector (A), LH exhaust camshaft CMP sensor connector (B) and LH oxygen sensor connector (C).

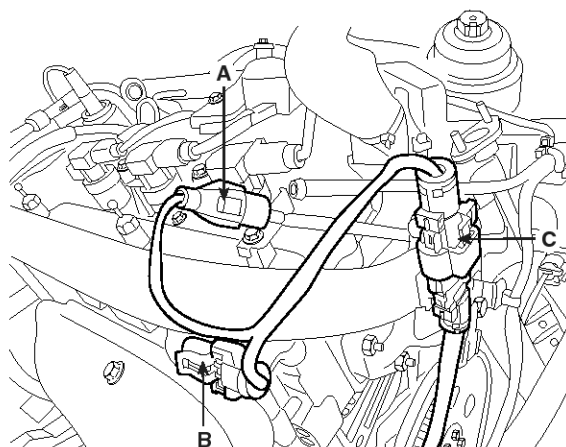

SBHEM8029D

## EM-134

## Engine Mechanical System

- 5) Disconnect the LH injector connector (A) and LH ignition coil connector (B).

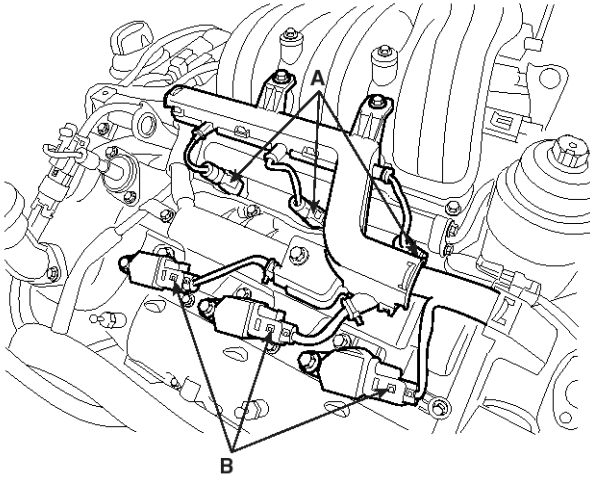

SBHEM8027D

- 6) Connect the LH knock sensor connector (A), LH/RH intake OCV connector (B) and LH exhaust OCV connector (C).

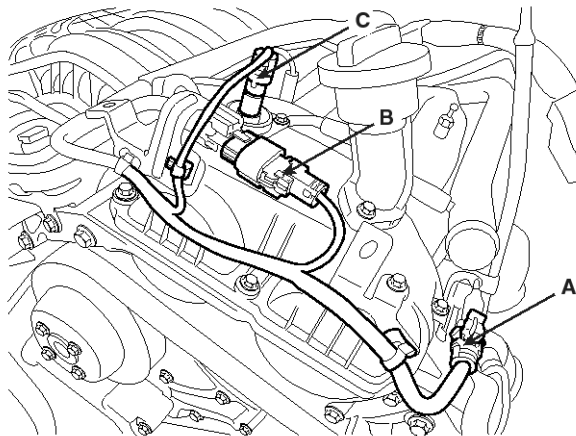

SBHEM8026D

- 7) Connect the MAP sensor connector (A), ETC connector (B), RH exhaust OCV connector (C), RH injector connector (D) and RH ignition coil connector (E).

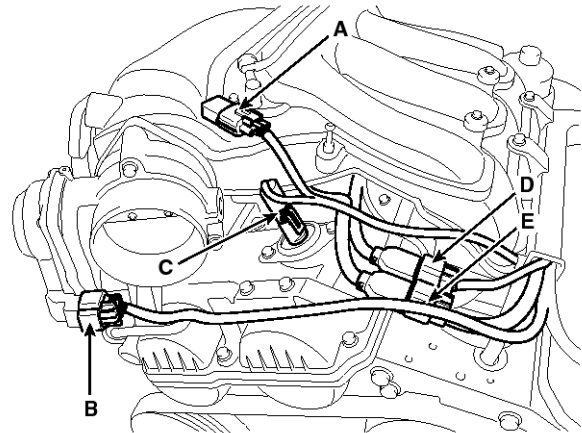

SHMEM9007L

- 8) Connect the power steering oil pressure switch connector (A) and RH knock sensor connector (B).

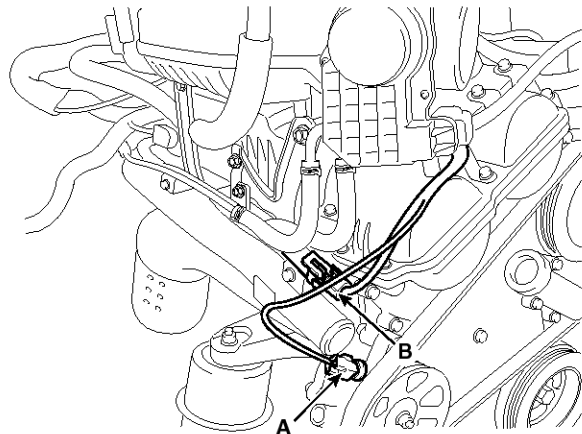

SHMEM9006L

# Intake And Exhaust System

# EM-135

6. Install the fuel pipe (A).

**Tightening torque :**

9.8 ~ 11.8N.m (1.0 ~ 1.2kgf.m, 7.2 ~ 8.7lb-ft)

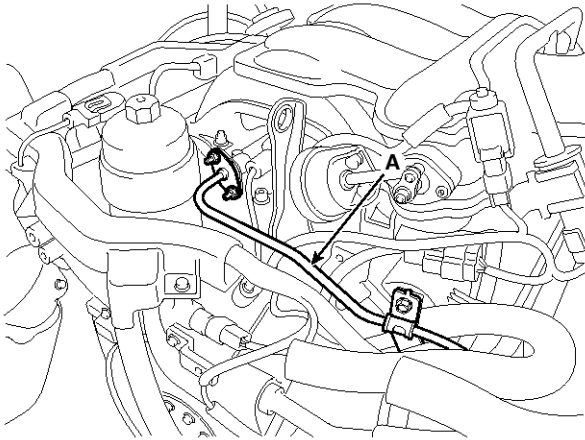

SHMEM9021L

7. Connect the heater hoses (A), the fuel hose (B), the purge control solenoid valve (PCSV) hose (C) and the brake booster vacuum hose (D).

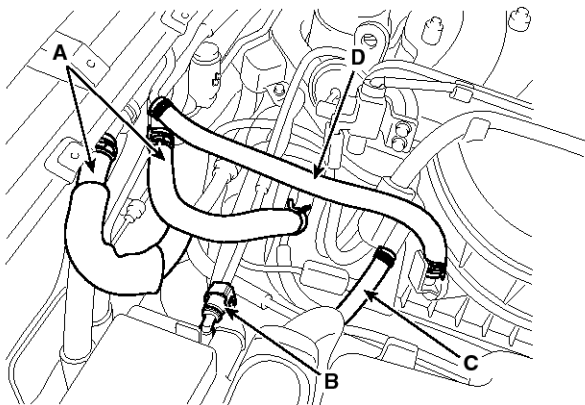

SHMEM9004L

8. Install the air cleaner assembly (C), and connect the AFS connector (A), breather hose (B).

**Tightening torque :**

7.8 ~ 9.8N.m (0.8 ~ 1.0kgf.m, 5.8 ~ 7.2lb-ft)

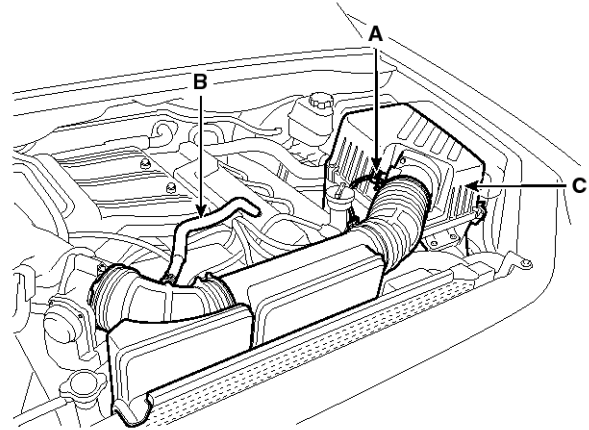

SHMEM9002L

9. Install the radiator grill upper guard (A).

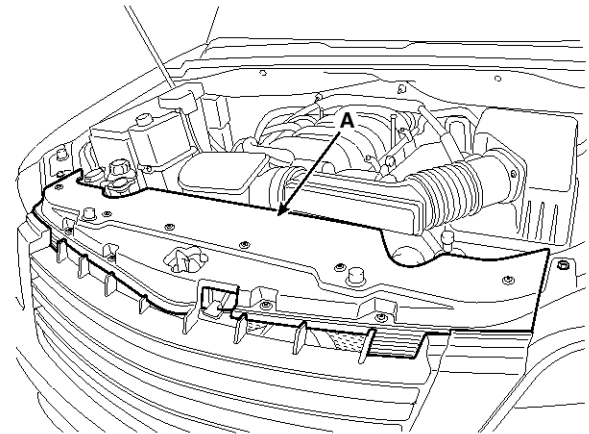

SHMM19045N

## EM-136

## Engine Mechanical System

10. Install the engine cover (A).

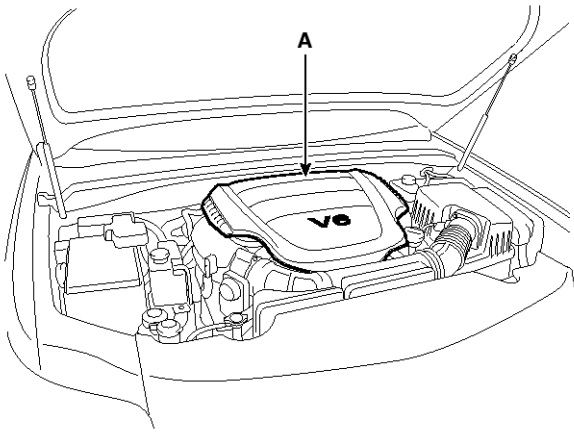

SHMEM9001L

11. Connect the battery negative cable (A).

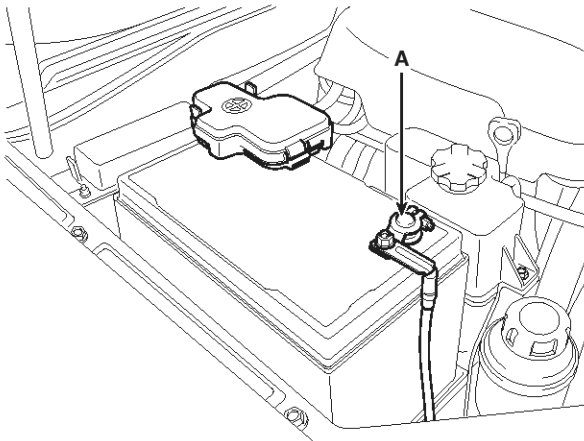

SHMM19043N

### NOTICE

- Refill engine coolant.
- Refill radiator and reservoir tank with engine coolant.
- Bleed air from the cooling system.
  - Start engine and let it run until it warms up. (Until the radiator fan operates 3 or 4 times.)
  - Turn Off the engine. Check the level in the radiator, add coolant if needed. This will allow trapped air to be removed from the cooling system.
  - Put radiator cap on tightly, then run the engine again and check for leaks.
- Clean the battery posts and cable terminals with sandpaper. Assemble and, then apply grease to prevent corrosion.

# Intake And Exhaust System

EM-137

## Exhaust Manifold

### Components

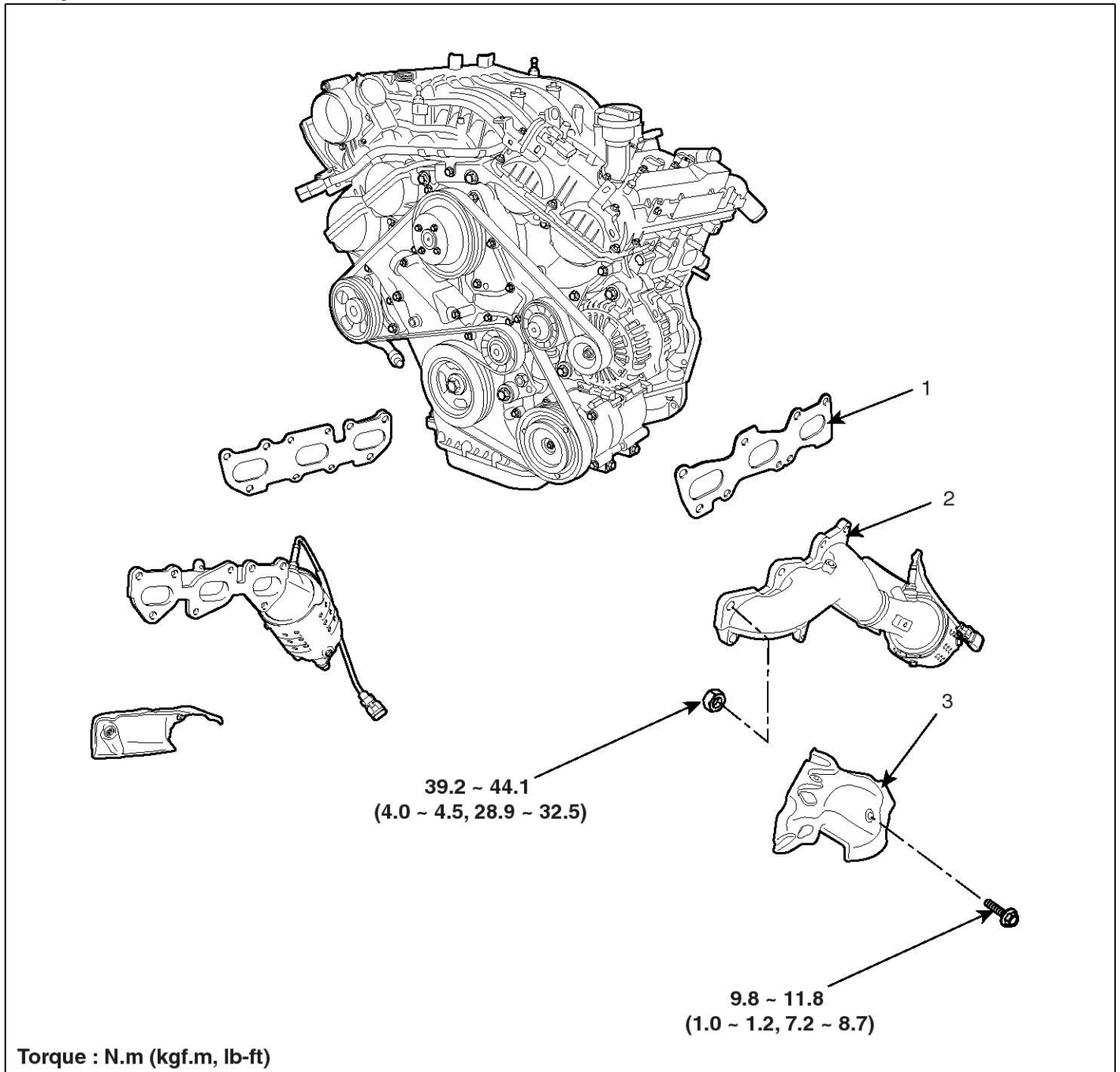

SBHEM9089L

- 1. Gasket
- 2. Exhaust manifold

- 3. Heat protector

## EM-138

## Engine Mechanical System

### Removal

#### ⚠ CAUTION

- To avoid damage, unplug the wiring connectors carefully while holding the connector portion.

#### 📌 NOTICE

- Mark all wiring and hoses to avoid misconnection.
1. Disconnect the negative cable (A) from the battery.

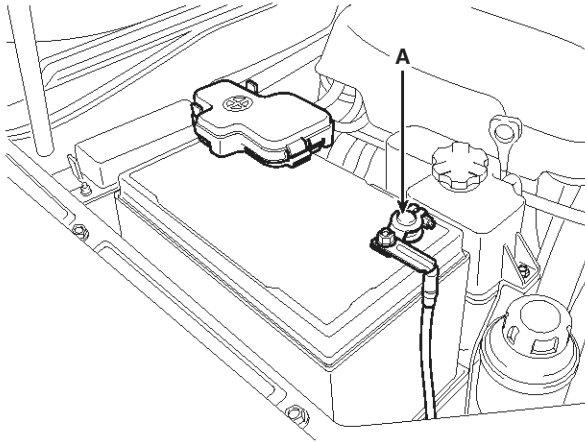

SHMM19043N

2. Loosen the drain plug and drain the engine coolant. Remove the radiator cap (A) to speed draining.

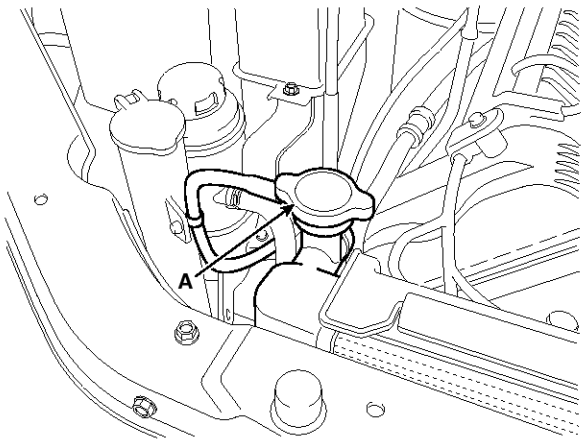

SHMM19047N

3. Remove the engine cover (A).

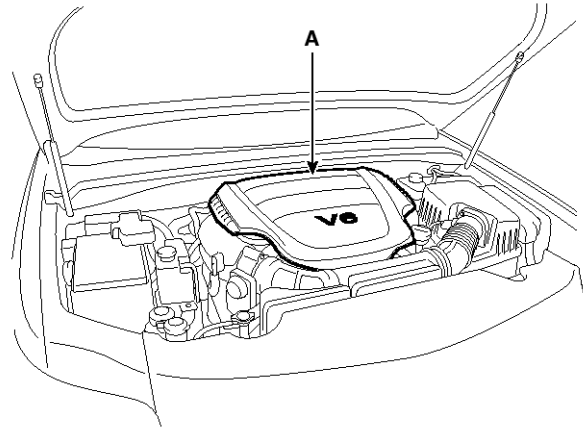

SHMEM9001L

4. Remove the radiator grill upper guard (A).

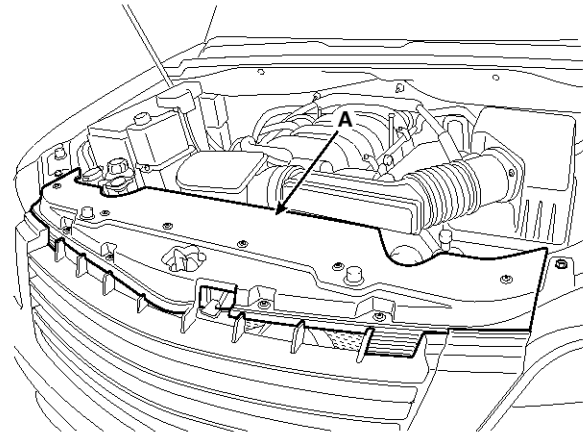

SHMM19045N

5. Disconnect the AFS connector (A) and breather hose (B) and then remove the air cleaner assembly (C).

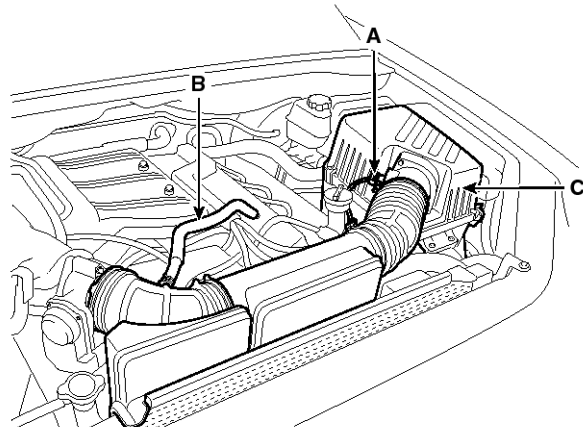

SHMEM9002L

# Intake And Exhaust System

EM-139

6. Disconnect the radiator upper hose (A) and lower hose (B).

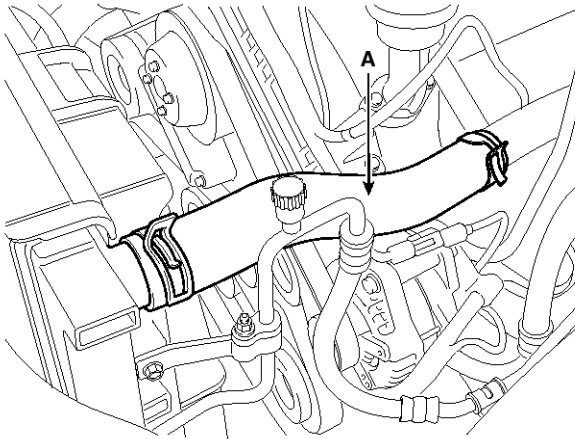

SHMEM9003L

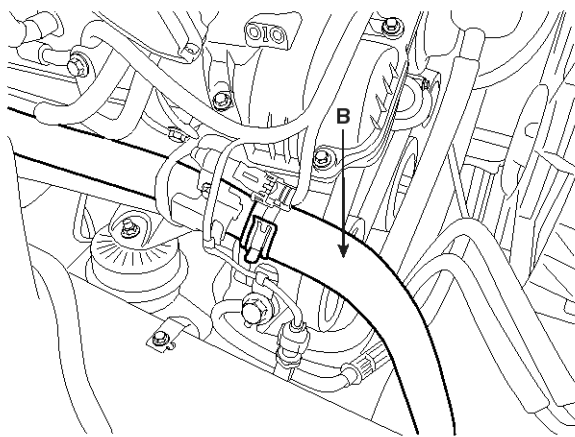

SBHEM8003D

7. Disconnect the LH oxygen sensor connector (A).

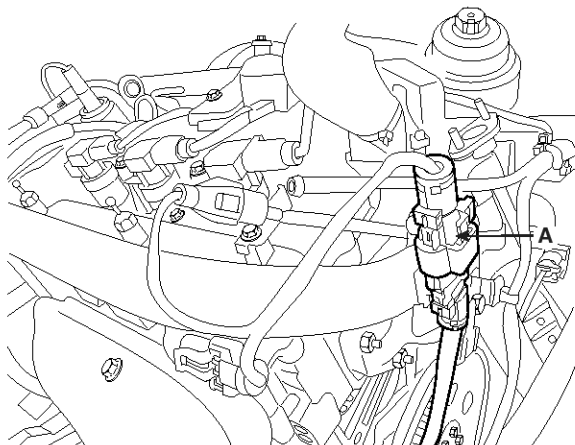

SHMEM9115L

8. Disconnect the RH oxygen sensor connector (A).

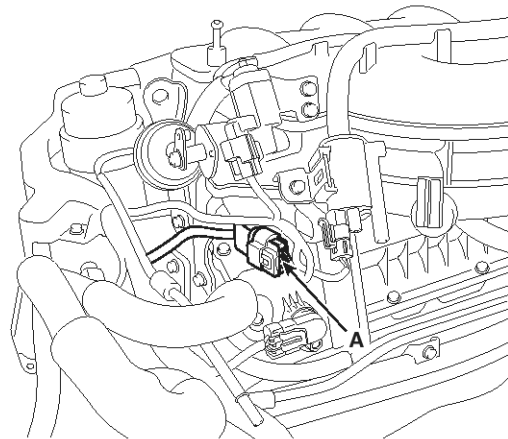

SHMEM9118L

9. Remove the oil level gauge tube (A).

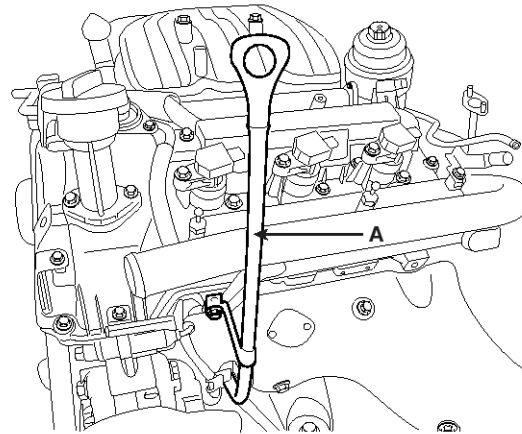

SBHEM8034D

10. Remove the LH side coolant pipe and hose (A).

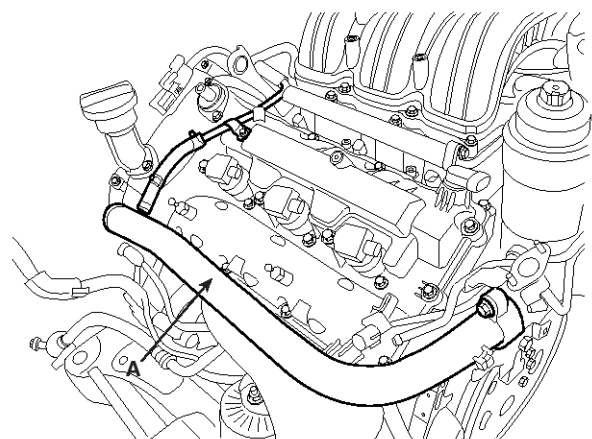

SBHEM8036D

## EM-140

## Engine Mechanical System

11. Remove the throttle body coolant hose & pipe (A) and the RH side coolant pipe (B).

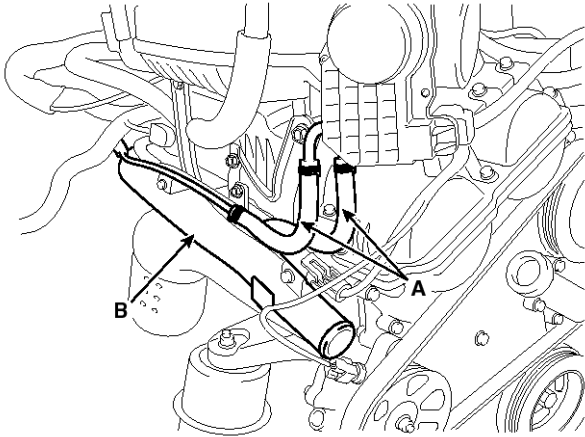

SHMEM9111L

12. Remove the LH/RH exhaust manifold stay bolt (A).

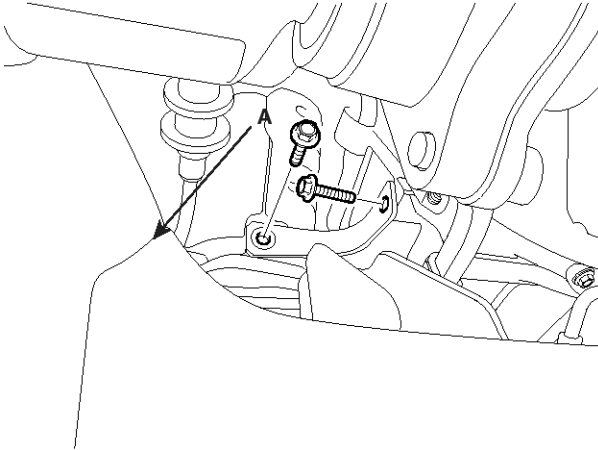

SHMEM9104L

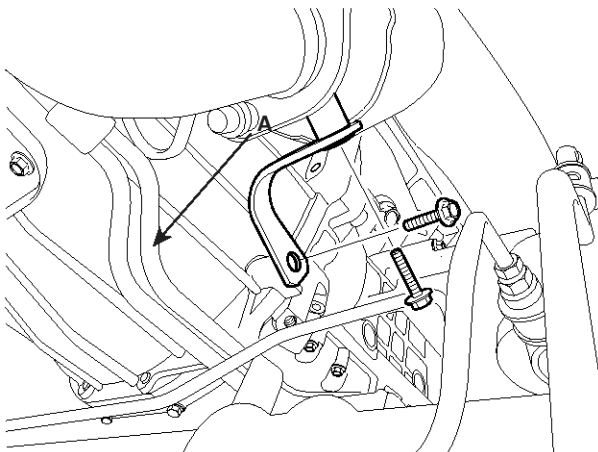

SHMEM9105L

13. Remove the LH/RH exhaust manifold heat protector (A).

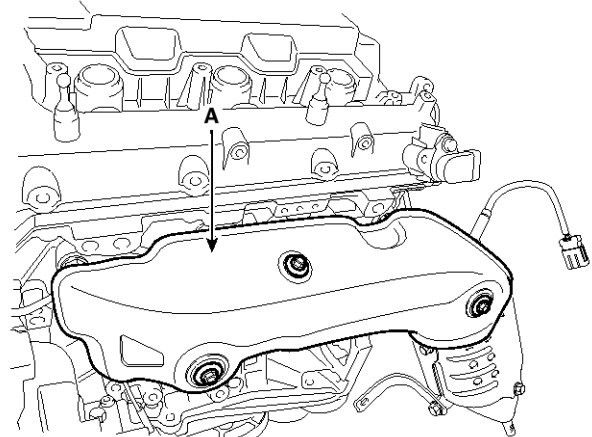

SHMEM9019L

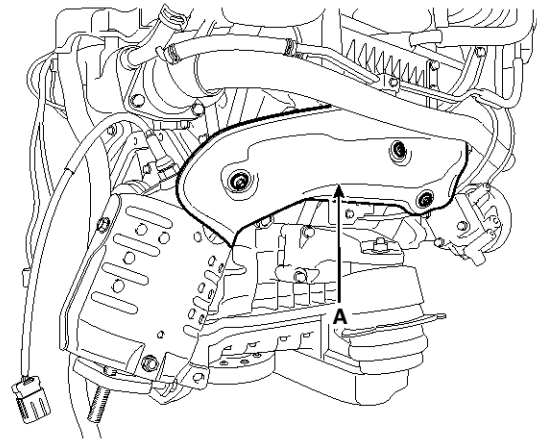

SHMEM9017L

# Intake And Exhaust System

EM-141

14. Remove the LH/RH exhaust manifold (A).

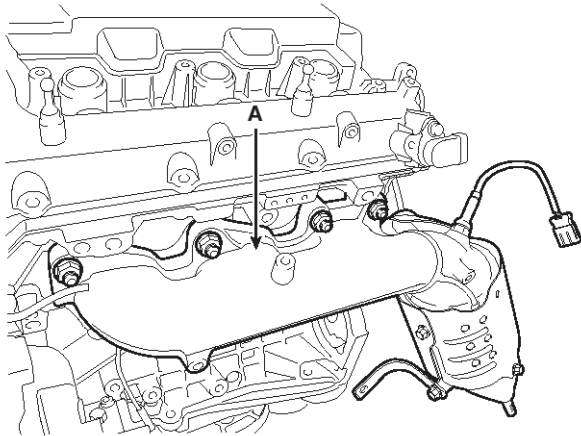

SHMEM9020L

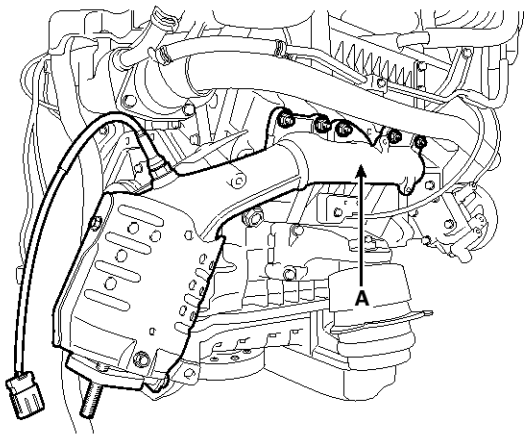

SHMEM9018L

## Installation

1. Install the LH/RH exhaust manifold (A).

### Tightening torque :

39.2 ~ 44.1N.m (4.0 ~ 4.5kgf.m, 28.9 ~ 32.5lb-ft)

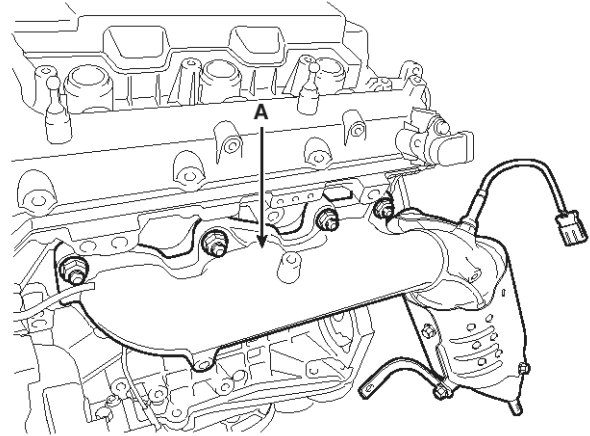

SHMEM9020L

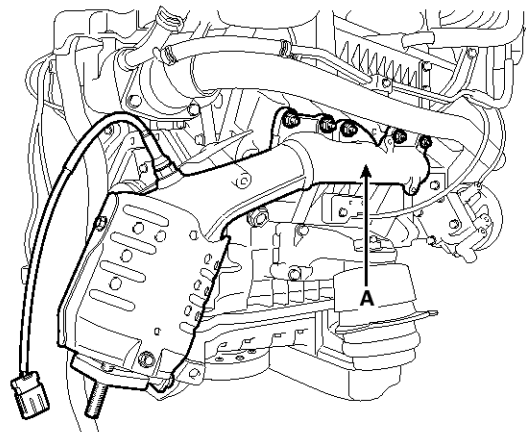

SHMEM9018L

## EM-142

## Engine Mechanical System

2. Install the LH/RH exhaust manifold heat protector (A).

**Tightening torque :**

9.8 ~ 11.8N.m (1.0 ~ 1.2kgf.m, 7.2 ~ 8.7lb-ft)

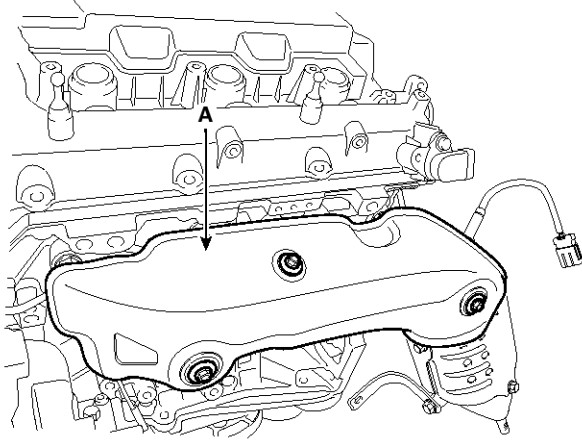

SHMEM9019L

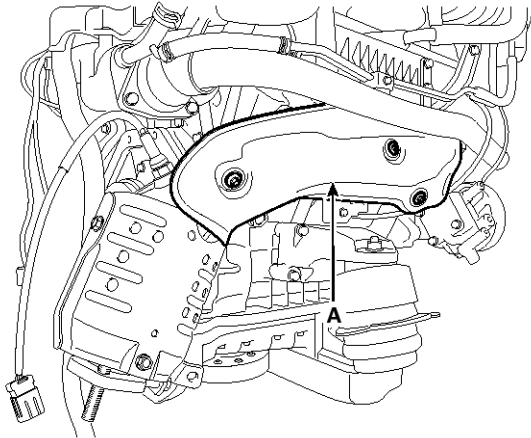

SHMEM9017L

3. Install the LH/RH exhaust manifold stay bolt (A).

**Tightening torque :**

34.3 ~ 41.2N.m (3.5 ~ 4.2kgf.m, 25.3 ~ 30.4lb-ft)

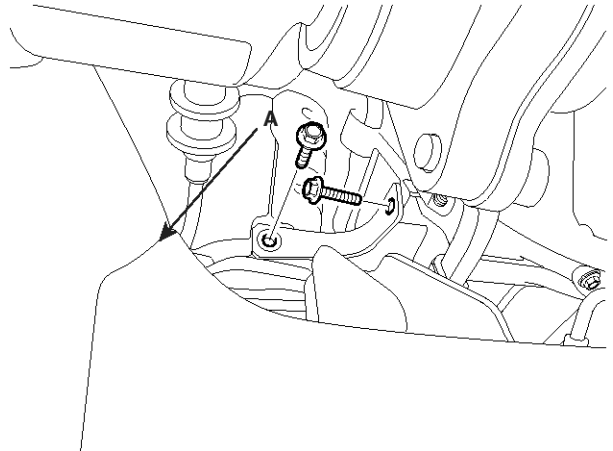

SHMEM9104L

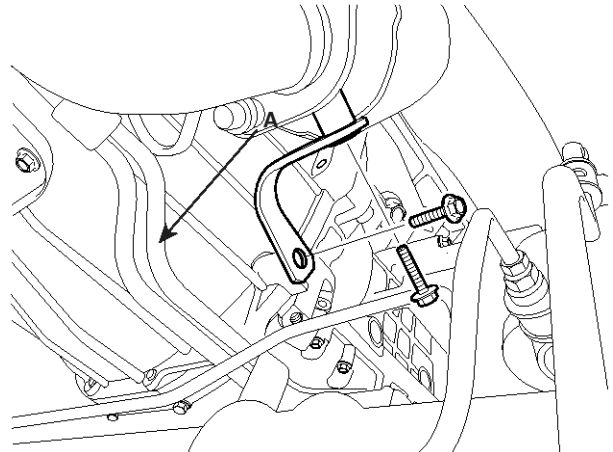

SHMEM9105L

# Intake And Exhaust System

EM-143

4. Install the throttle body coolant hose & pipe (A) and the RH side coolant pipe (B).

**Tightening torque**

(A): 9.8 ~ 11.8N.m (1.0 ~ 1.2kgf.m, 7.2 ~ 8.7lb-ft)

(B): 19.6 ~ 23.5Nm (2.0 ~ 2.4kgf.m, 14.5 ~ 17.4lb-ft)

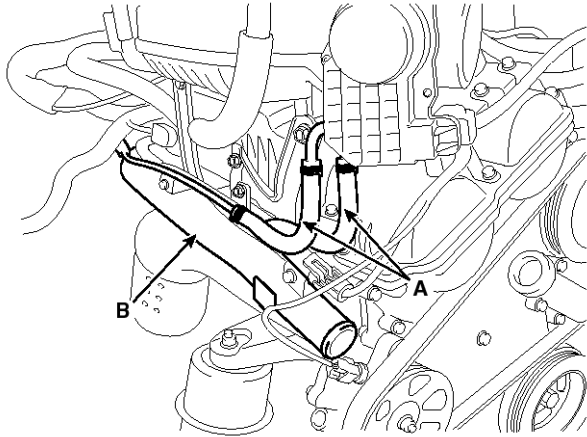

SHMEM9111L

5. Install the LH side coolant pipe and hose (A).

**Tightening torque :**

19.6 ~ 23.5Nm (2.0 ~ 2.4kgf.m, 14.5 ~ 17.4lb-ft)

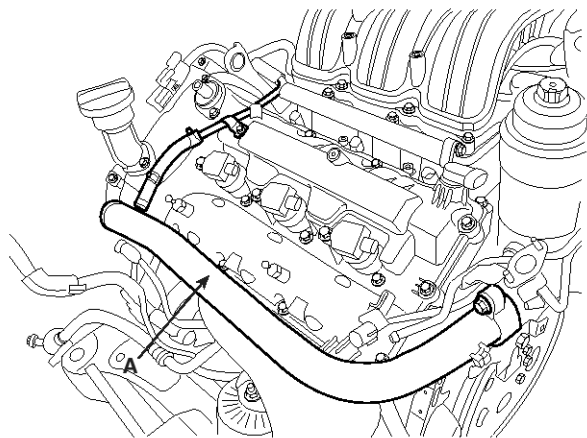

SBHEM8036D

6. Install the oil level gauge tube (A).

**Tightening torque :**

18.6 ~ 22.6N.m (1.9 ~ 2.3kgf.m, 13.7 ~ 16.6lb-ft)

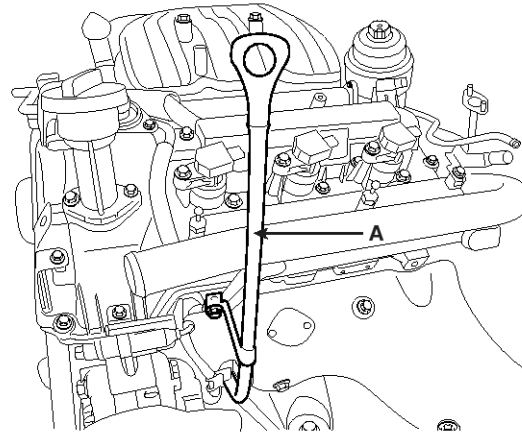

SBHEM8034D

7. Connect the RH oxygen sensor connector (A).

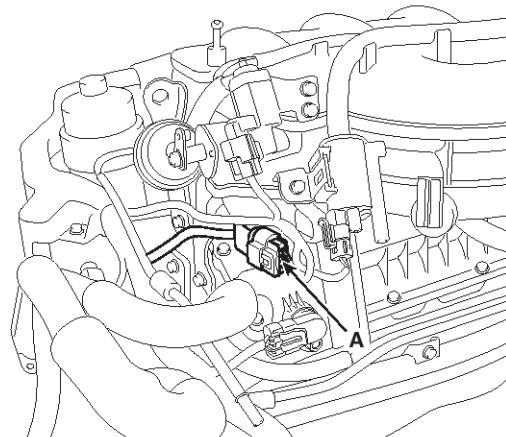

SHMEM9118L

8. Connect the LH oxygen sensor connector (A).

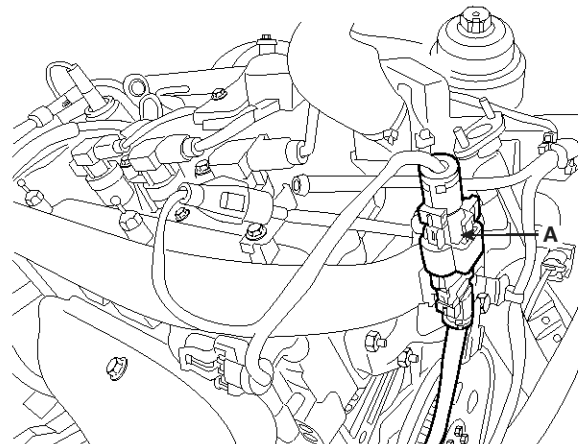

SHMEM9115L

## EM-144

## Engine Mechanical System

9. Connect the radiator upper hose (A) and lower hose (B).

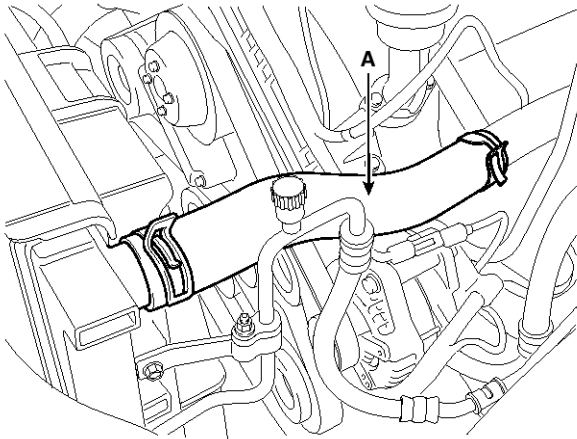

SHMEM9003L

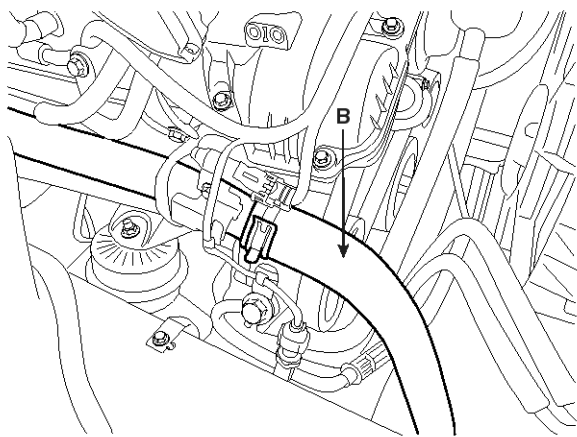

SBHEM8003D

10. Install the air cleaner assembly (C), and connect the AFS connector (A), breather hose (B).

**Tightening torque :**

7.8 ~ 9.8N.m (0.8 ~ 1.0kgf.m, 5.8 ~ 7.2lb-ft)

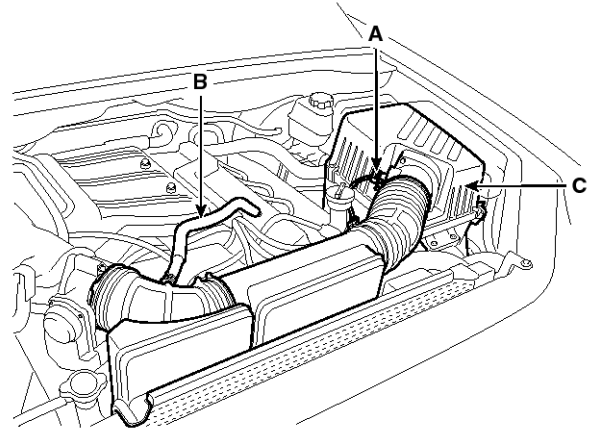

SHMEM9002L

11. Install the radiator grill upper guard (A).

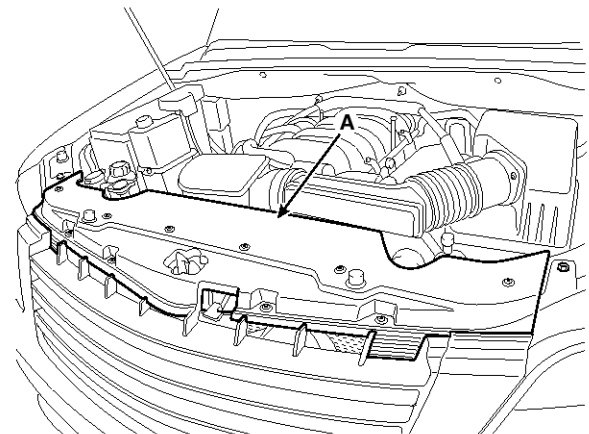

SHMM19045N

# Intake And Exhaust System

EM-145

12. Install the engine cover (A).

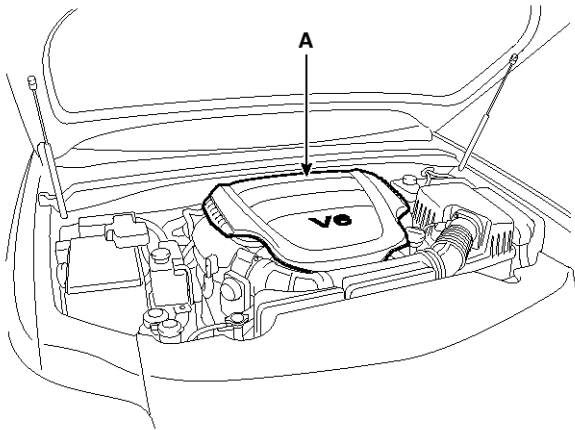

SHMEM9001L

13. Connect the battery negative cable (A).

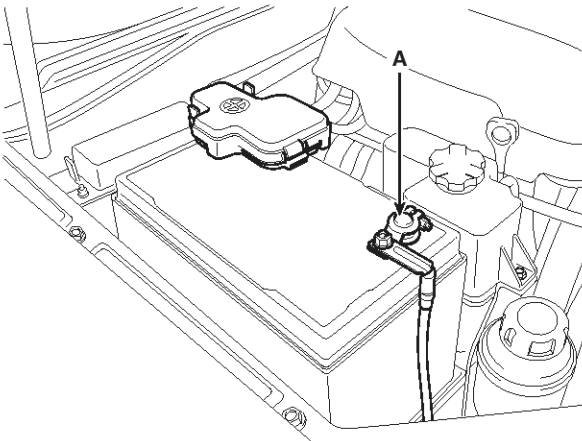

SHMM19043N

## NOTICE

- Refill engine coolant.
- Refill radiator and reservoir tank with engine coolant.
- Bleed air from the cooling system.
  - Start engine and let it run until it warms up. (Until the radiator fan operates 3 or 4 times.)
  - Turn Off the engine. Check the level in the radiator, add coolant if needed. This will allow trapped air to be removed from the cooling system.
  - Put radiator cap on tightly, then run the engine again and check for leaks.
- Clean the battery posts and cable terminals with sandpaper. Assemble and, then apply grease to prevent corrosion.

**Muffler**

**Removal**

1. Remove the front muffler (A).

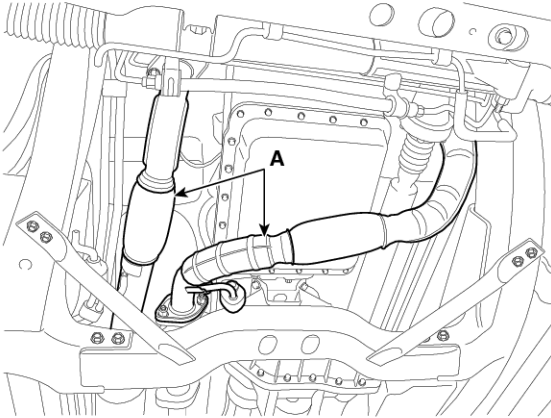

SHMEM9119L

2. Remove the center muffler (A).

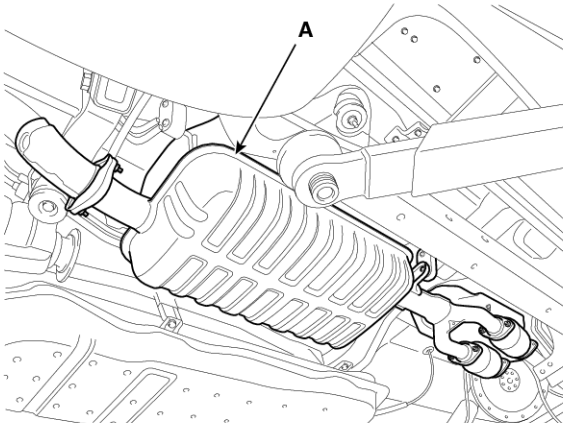

SHMM19138N

3. Remove the main muffler (A).

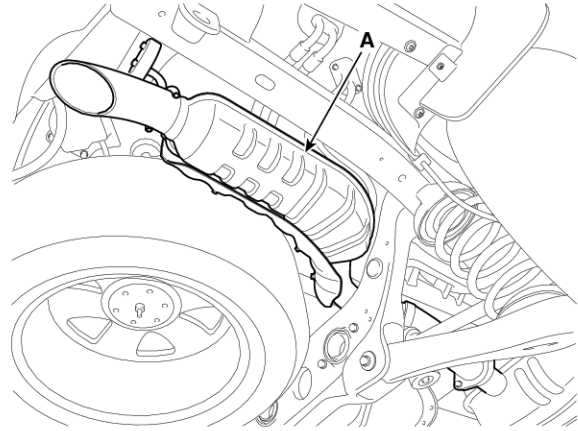

SHMM19139N

# Intake And Exhaust System

EM-147

## Installation

1. Install the main muffler (A).

### Tightening torque :

39.2 ~ 58.8Nm (4.0 ~ 6.0kgf.m, 28.9 ~ 43.4lb-ft)

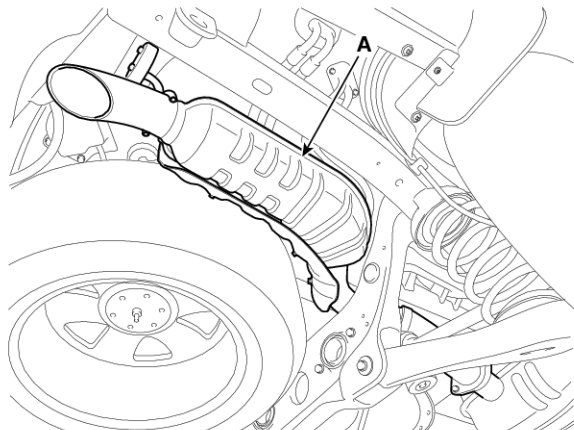

SHMM19139N

2. Install the center muffler (A).

### Tightening torque :

39.2 ~ 58.8Nm (4.0 ~ 6.0kgf.m, 28.9 ~ 43.4lb-ft)

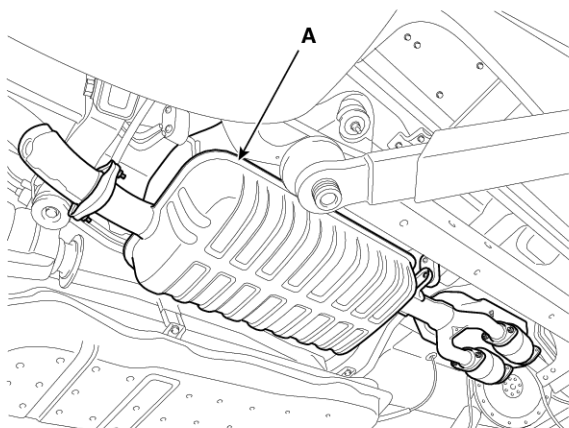

SHMM19138N

3. Install the front muffler (A).

### Tightening torque :

39.2 ~ 58.8Nm (4.0 ~ 6.0kgf.m, 28.9 ~ 43.4lb-ft)

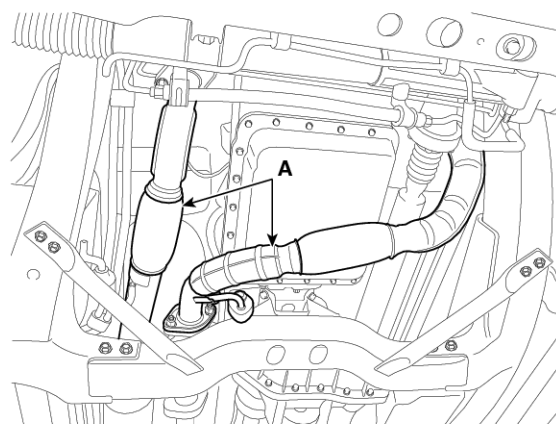

SHMEM9119L