

Engine Electrical System

GENERAL

IGNITION SYSTEM

CHARGING SYSTEM

ALTERNATOR
BATTERY

STARTING SYSTEM

STARTER
STARTER RELAY

CRUISE CONTROL SYSTEM

CRUISE CONTROL MAIN SWITCH

GENERAL

SPECIFICATIONS E2C310C0

IGNITION SYSTRM

Items		Specification	
Ignition coil	Primary resistance	0.62 ± 10 %	
	Secondary resistance	7.0kΩ ± 15 %	
Spark plugs	Unleaded	NGK	IFR5G-11
		Gap	1.0 ~ 1.1 mm (0.0394 ~ 0.0433 in.)
	Leaed	NGK	BKR5ES
		Gap	0.8 ~ 0.9 mm (0.0315 ~ 0.0354 in)

STARTING SYSTEM

Items		Specification	
Starter	Rated voltage	12 V, 1.4 kW	
	No. of pinion teeth	8	
	No-load characteristics	Voltage	11.5 V
		Ampere	85A, MAX
		Speed	2,600 rpm, MIN

CHARGING SYSTEM

Items		Specification
Alternator	Rate voltage	13.5 V, 130A
	Speed in use	1,000 ~ 18,000 rpm
	Voltage regulator	IC regulator built-in type
	Regulator setting voltage	14.2 ~ 14.8 V (500 RPM, 10A, 25°C)
Battery	Type	CMF 80AH
	Cold cranking amperage [at -18°C(-0.4°F)]	660 A
	Reserve capacity	145 min
	Specific gravity [at 25°C(77°F)]	1.280 ± 0.01

 **NOTE**

- *COLD CRANKING AMPERAGE* is the amperage a battery can deliver for 30 seconds and maintain a terminal voltage of 7.2V or greater at a specified temperature.
- *RESERVE CAPACITY RATING* is amount of time a battery can deliver 25A and maintain a minimum terminal voltage of 10.5V at 26.7°C(80.1°F).

TROUBLESHOOTING

EB8238FF

IGNITION SYSTEM

Symptom	Suspect area	Remedy
Engine will not start or is hard to start (Crank OK)	Ignition lock switch Ignition coil Spark plugs Ignition wiring disconnected or broken	Inspect ignition lock switch, or replace as required Inspect ignition coil, or replace as required Inspect spark plugs, or replace as required Repair wiring, or replace as required
Rough idle or stalls	Ignition wiring Ignition coil	Repair wiring, or replace as required Inspect ignition coil, or replace as required
Engine hesitates/poor acceleration	Spark plugs and spark plug cables Ignition wiring	Inspect spark plugs / cable, or replace as required Repair wiring, or replace as required
Poor mileage	Spark plugs and spark plug cables	Inspect spark plugs / cable, or replace as required

CHARGING SYSTEM

Symptom	Suspect area	Remedy
Charging warning indicator does not light with ignition switch "ON" and engine off.	Fuse blown Light burned out Wiring connection loose Electronic voltage regulator	Check fuses Replace light Tighten loose connection Replace voltage regulator
Charging warning indicator does not go out with engine running. (Battery requires frequent recharging)	Drive belt loose or worn Battery cable loose, corroded or worn Electronic voltage regulator or alternator Wiring	Adjust belt tension or replace belt Inspect cable connection, repair or replace cable Replace voltage regulator or alternator Repair or replace wiring
Overcharge	Electronic voltage regulator Voltage sensing wire	Replace voltage regulator Repair or replace wiring
Discharge	Drive belt loose or worn Wiring connection loose or short circuit Electronic voltage regulator or alternator Poor grounding Worn battery	Adjust belt tension or replace belt Inspect wiring connection, repair or replace wiring Replace voltage regulator or alternator Inspect ground or repair Replace battery

STARTING SYSTEM

Symptom	Suspect area	Remedy
Engine will not crank	Battery charge low Battery cables loose, corroded or worn out Transaxle range switch (Vehicle with automatic transaxle only) Fuse blown Starter motor faulty Ignition switch faulty	Charge or replace battery Repair or replace cables Refer to TR group-automatic transaxle Replace fuse Replace Replace
Engine cranks slowly	Battery charge low Battery cables loose, corroded or worn out Starter motor faulty	Charge or replace battery Repair or replace cables Replace
Starter keeps running	Starter motor Ignition switch	Replace Replace
Starter spins but engine will not crank	Short in wiring Pinion gear teeth broken or starter motor Ring gear teeth broken	Repair wiring Replace Replace fly wheel or torque converter

IGNITION SYSTEM

DESCRIPTION EDD5F497

Ignition timing is controlled by the electronic control ignition timing system. The standard reference ignition timing data for the engine operating conditions are preprogrammed in the memory of the PCM (Power Control Module).

The engine operating conditions (speed, load, warm-up condition, etc.) are detected by the various sensors. Based on these sensor signals and the ignition timing data, signals to interrupt the primary current are sent to the PCM. The ignition coil is activated, and timing is controlled.

COMPONENTS EA2AD0E3

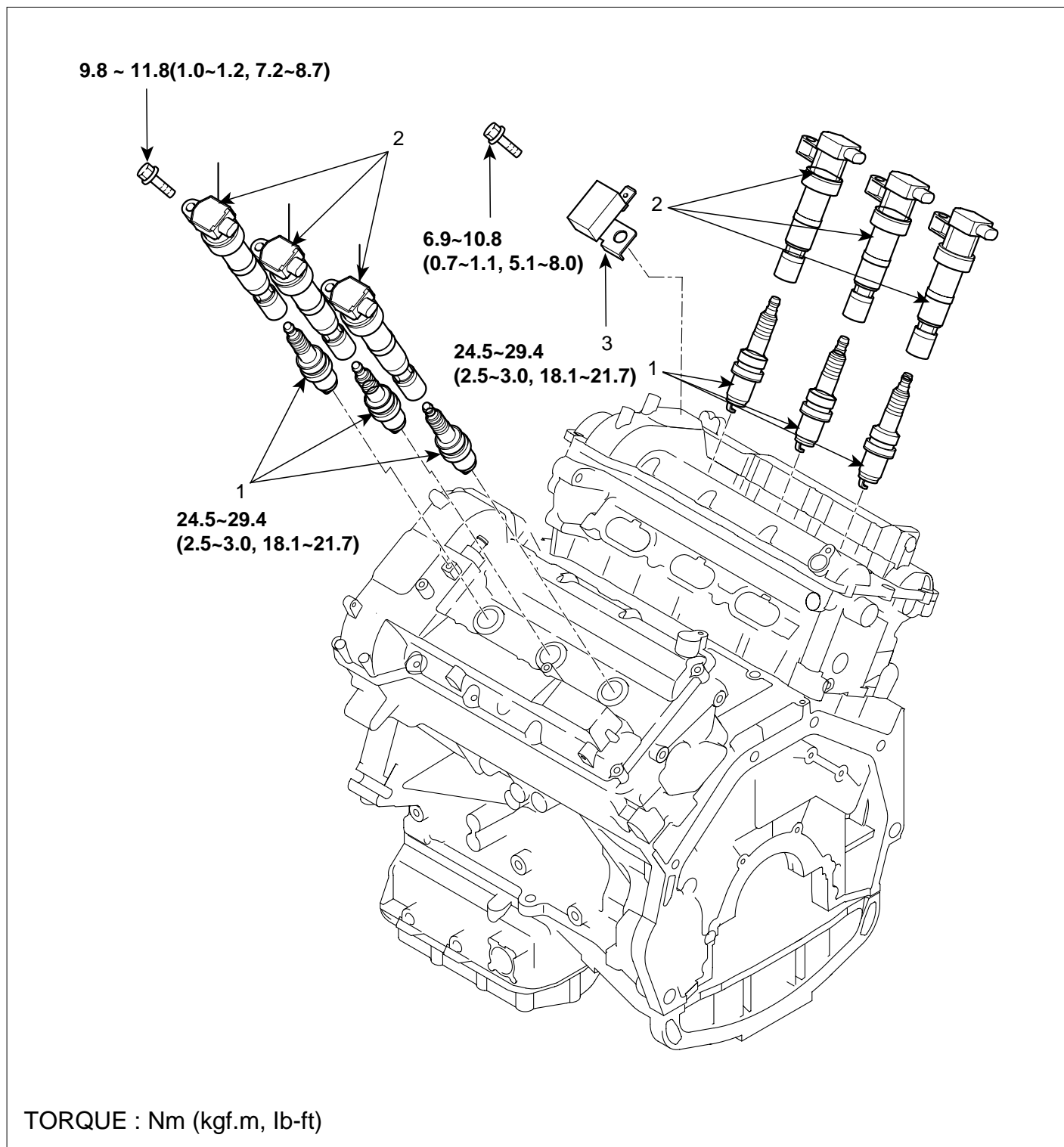

- 1. Spark plug
- 2. Ignition coil
- 3. Condenser

SGHEE7001N

IGNITION SYSTEM

EE -7

ON-VEHICLE INSPECTION E63242EF

SPARK TEST

1. Remove the ignition coil connector(A).

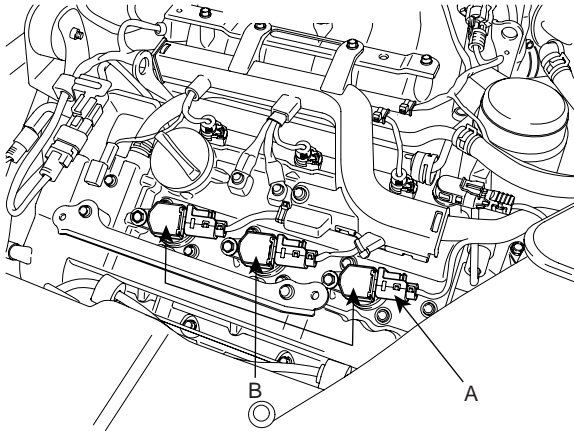

SGHEE7002N

2. Remove the ignition coil(B).
3. Using a spark plug socket, remove the spark plug.
4. Install the spark plug to the ignition coil.
5. Ground the spark plug to the engine.

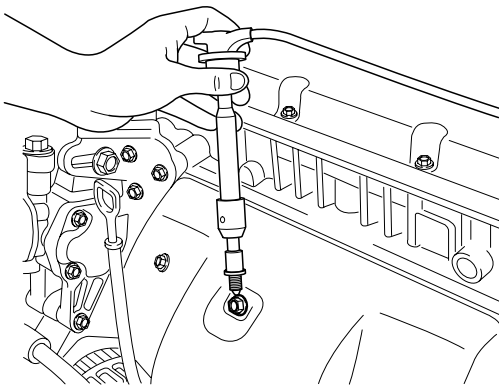

ABGE001A

6. Check if spark occurs while engine is being cranked.

NOTE

To prevent fuel being injected from injectors while the engine is being cranked, remove the fuel pump(A) relay from the fuse box.

Crank the engine for no more than 5 ~ 10 seconds.

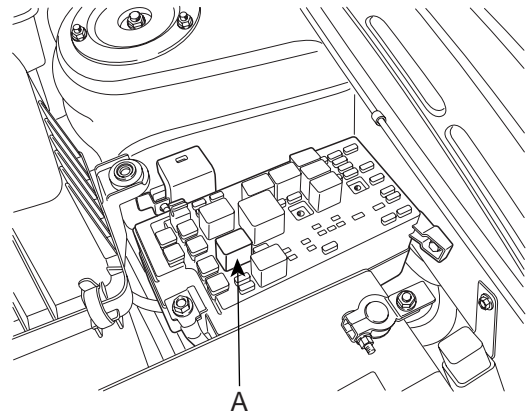

SGHEE7003N

7. Inspect all the spark plugs.
8. Using a spark plug socket, install the spark plug.
9. Install the ignition coil.
10. Reconnect the ignition coil connector.

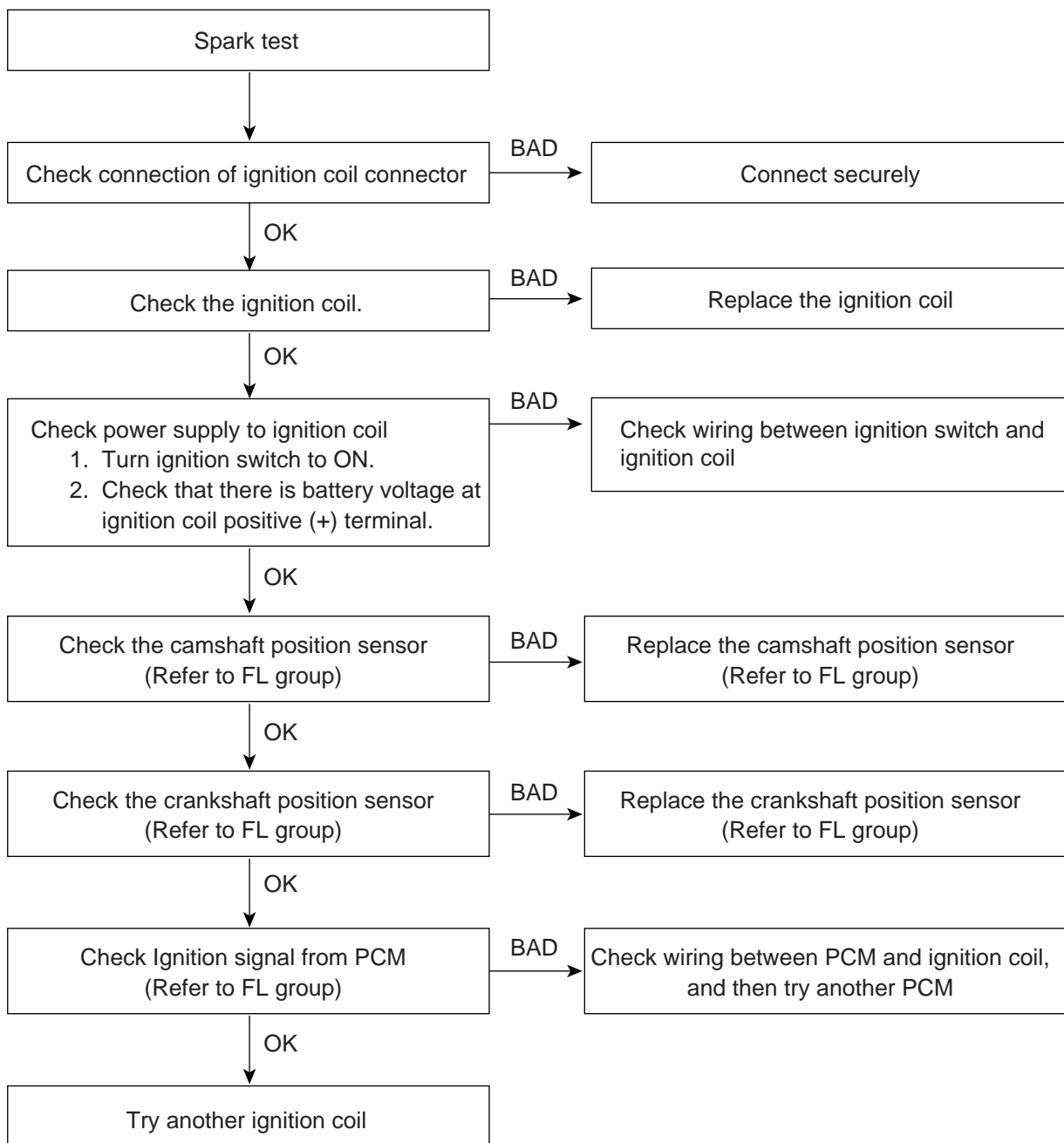

SGHEE7009N

IGNITION SYSTEM

EE -9

SPARK PLUG

1. Remove the ignition coil connector(A).

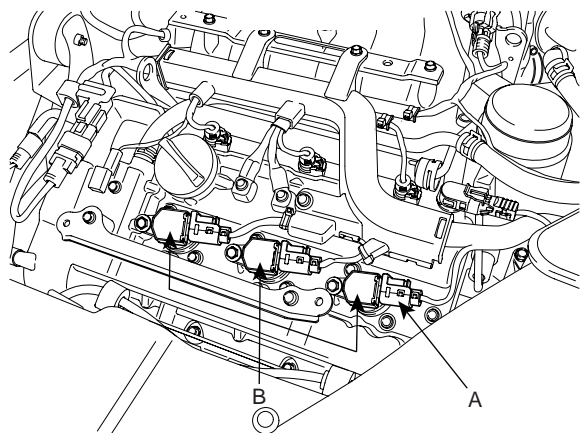

SGHEE7002N

NOTE

When removing the ignition coil connector, pull the lock pin(A) and push the clip(B).

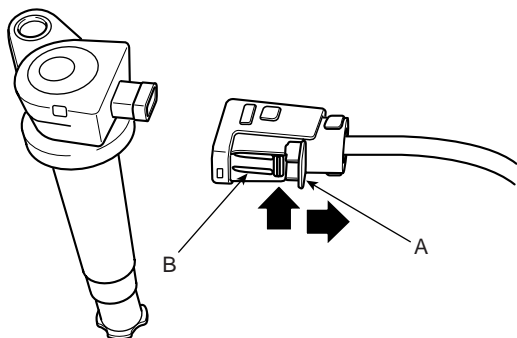

ABGE003A

2. Remove the ignition coil(B).
3. Using a spark plug socket, remove the spark plug.

CAUTION

Be careful that no contaminants enter through the spark plug holes.

4. Inspect the electrodes (A) and ceramic insulator (B).

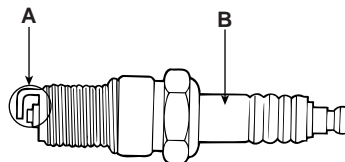

EBKD002K

INSPECTION OF ELECTRODES

Condition	Dark deposits	White deposits
Description	<ul style="list-style-type: none"> - Fuel mixture too rich - Low air intake 	<ul style="list-style-type: none"> - Fuel mixture too lean - Advanced ignition timing - Insufficient plug tightening torque

5. Check the electrode gap (A).

Standard :
 1.0 ~ 1.1 mm (0.0394 ~ 0.0433 in.) - Unleaded
 0.8 ~ 0.9 mm (0.0315 ~ 0.0354 in) - Leaded

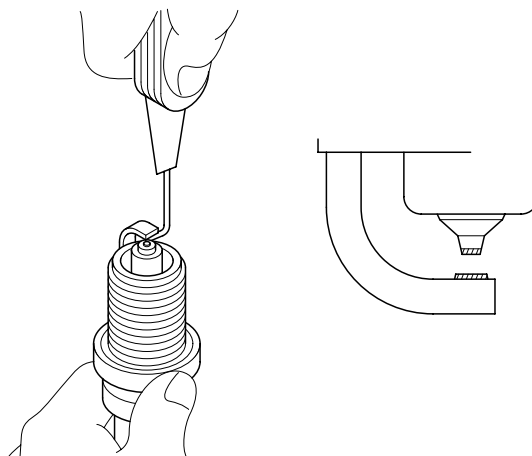

EBKE002L

IGNITION COIL

1. Measure the primary coil resistance between terminals (+) and (-).

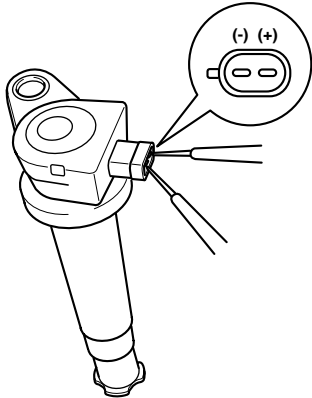

ABGE004A

Standard value: 0.62 ± 10%

REMOVAL E56FAFD7

IGNITION COIL

1. Remove the engine cover.
2. Disconnect the ignition coil connector(A).

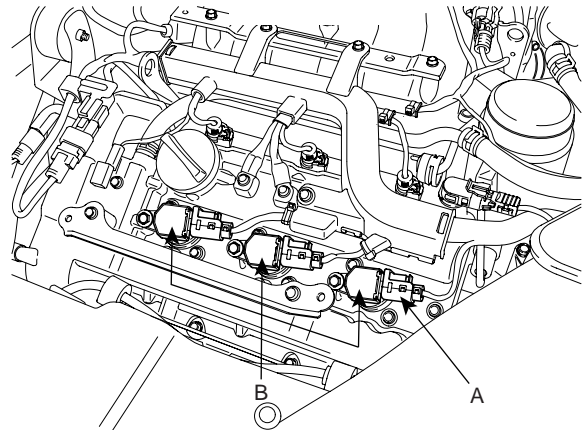

SGHEE7002N

NOTE

When removing the ignition coil connector, pull the lock pin(A) and push the clip(B).

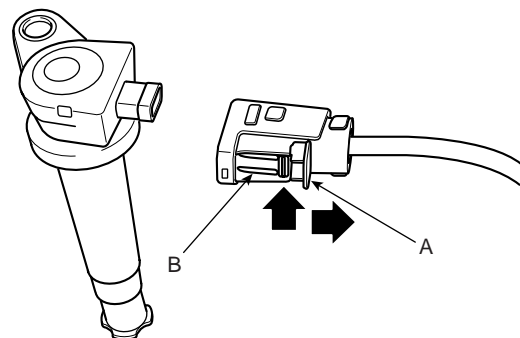

ABGE003A

3. Remove the ignition coil (B).
4. Installation is the reverse of removal.

CHARGING SYSTEM

DESCRIPTION EC071E4B

The charging system includes a battery, an alternator with a built-in regulator, and the charging indicator light and wire.

The Alternator has built-in diodes, each rectifying AC current to DC current.

Therefore, DC current appears at alternator "B" terminal. In addition, the charging voltage of this alternator is regulated by the battery voltage detection system.

The main components of the alternator are the rotor, stator, rectifier, capacitor brushes, bearings and V-ribbed belt pulley. The brush holder contains a built-in electronic voltage regulator.

ON-VEHICLE INSPECTION EEBC71BE

CAUTION

- **Check that the battery cables are connected to the correct terminals.**
- **Disconnect the battery cables when the battery is given a quick charge.**
- **Never disconnect the battery while the engine is running.**

CHECK THE BATTERY TERMINALS AND FUSES

1. Check that the battery terminals are not loose or corroded.
2. Check the fuses for continuity.

INSPECT DRIVE BELT

Visually check the belt for excessive wear, frayed cords etc.

If any defect has been found, replace the drive belt.

NOTE

Cracks on the rib side of a belt are considered acceptable. If the belt has chunks missing from the ribs, it should be replaced.

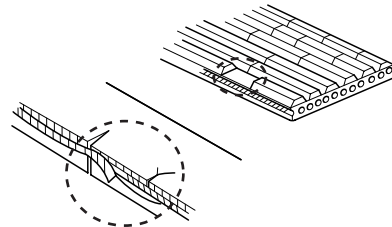

EBKD004B

VISUALLY CHECK ALTERNATOR WIRING AND LISTEN FOR ABNORMAL NOISES

1. Check that the wiring is in good condition.
2. Check that there is no abnormal noise from the alternator while the engine is running.

CHECK DISCHARGE WARNING LIGHT CIRCUIT

1. Warm up the engine and then turn it off.
2. Turn off all accessories.
3. Turn the ignition switch "ON". Check that the discharge warning light is lit.
4. Start the engine. Check that the light is lit.
If the light does not go off as specified, troubleshoot the discharge light circuit.

VOLTAGE DROP TEST OF ALTERNATOR OUTPUT WIRE

This test determines whether or not the wiring between the alternator "B" terminal and the battery (+) terminal is good by the voltage drop method.

PREPARATION

1. Turn the ignition switch to "OFF".
2. Disconnect the output wire from the alternator "B" terminal. Connect the (+) lead wire of ammeter to the "B" terminal of alternator and the (-) lead wire of ammeter to the output wire. Connect the (+) lead wire of voltmeter to the "B" terminal of alternator and the (-) lead wire of voltmeter to the (+) terminal of battery.

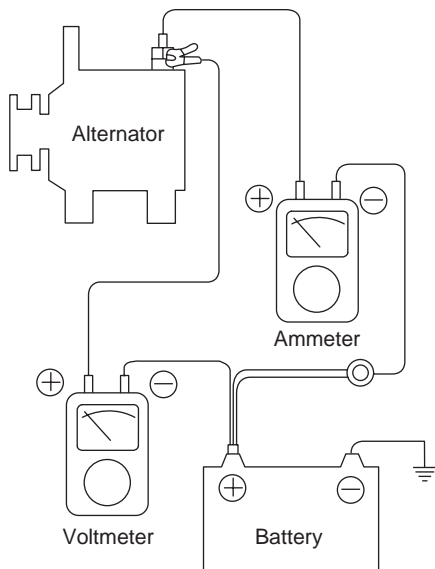

BBGE002A

TEST

1. Start the engine.
2. Turn on the headlamps and blower motor, and set the engine speed until the ammeter indicates 20A. And then, read the voltmeter at this time.

RESULT

1. The voltmeter may indicate the standard value.

Standard value: 0.2V max

2. If the value of the voltmeter is higher than expected (above 0.2V max.), poor wiring is suspected. In this case check the wiring from the alternator "B" terminal to the battery (+) terminal. Check for loose connections, color change due to an over-heated harness, etc. Correct them before testing again.
3. Upon completion of the test, set the engine speed at idle.
Turn off the headlamps, blower motor and the ignition switch.

OUTPUT CURRENT TEST

This test determines whether or not the alternator gives an output current that is equivalent to the normal output.

PREPARATION

1. Prior to the test, check the following items and correct as necessary.
Check the battery installed in the vehicle to ensure that it is in good condition. The battery checking method is described in the section "Battery".
The battery that is used to test the output current should be one that has been partially discharged. With a fully charged battery, the test may not be conducted correctly due to an insufficient load.
Check the tension of the alternator drive belt. The belt tension check method is described in the section "Inspect drive belt".
2. Turn off the ignition switch.
3. Disconnect the battery ground cable.
4. Disconnect the alternator output wire from the alternator "B" terminal.
5. Connect a DC ammeter (0 to 150A) in series between the "B" terminal and the disconnected output wire. Be sure to connect the (-) lead wire of the ammeter to the disconnected output wire.

NOTE

Tighten each connection securely, as a heavy current will flow. Do not rely on clips.

6. Connect a voltmeter (0 to 20V) between the "B" terminal and ground. Connect the (+) lead wire to the alternator "B" terminal and (-) lead wire to a good ground.
7. Attach an engine tachometer and connect the battery ground cable.
8. Leave the engine hood open.

TEST

1. Check to see that the voltmeter reads as the same value as the battery voltage. If the voltmeter reads 0V, and the open circuit in the wire between alternator "B" terminal and battery (-) terminal or poor grounding is suspected.
2. Start the engine and turn on the headlamps.
3. Set the headlamps to high beam and the heater blower switch to HIGH, quickly increase the engine speed to 2,500 rpm and read the maximum output current value indicated by the ammeter.

NOTE

After the engine start up, the charging current quickly drops.

Therefore, the above operation must be done quickly to read the maximum current value correctly.

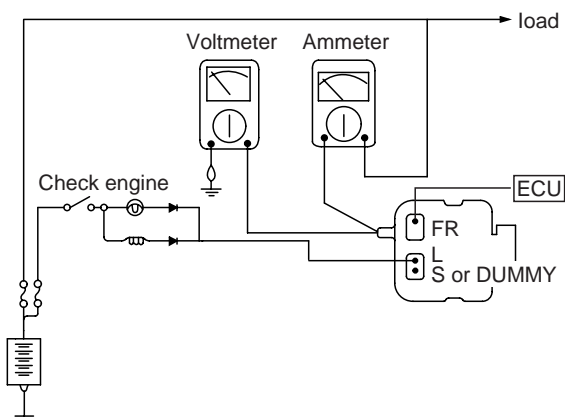

SCMEE6022N

RESULT

1. The ammeter reading must be higher than the limit value. If it is lower but the alternator output wire is in good condition, remove the alternator from the vehicle and test it.

Limit value : 65A min.

NOTE

- The nominal output current value is shown on the nameplate affixed to the alternator body.
- The output current value changes with the electrical load and the temperature of the alternator itself.

Therefore, the nominal output current may not be obtained. If such is the case, keep the headlamps on the cause discharge of the battery, or use the lights of another vehicle to increase the electrical load.

The nominal output current may not be obtained if the temperature of the alternator itself or ambient temperature is too high.

In such a case, reduce the temperature before testing again.

2. Upon completion of the output current test, lower the engine speed to idle and turn off the ignition switch.
3. Disconnect the battery ground cable.
4. Remove the ammeter and voltmeter and the engine tachometer.
5. Connect the alternator output wire to the alternator "B" terminal.
6. Connect the battery ground cable.

REGULATED VOLTAGE TEST

The purpose of this test is to check that the electronic voltage regulator controls voltage correctly.

PREPARATION

1. Prior to the test, check the following items and correct if necessary.
Check that the battery installed on the vehicle is fully charged. The battery checking method is described in the section "Battery".
Check the alternator drive belt tension. The belt tension check method is described in the section "Inspect drive belt".
2. Turn ignition switch to "OFF".
3. Disconnect the battery ground cable.
4. Connect a digital voltmeter between the "B" terminal of the alternator and ground. Connect the (+) lead of the voltmeter to the "B" terminal of the alternator. Connect the (-) lead to good ground or the battery (-) terminal.
5. Disconnect the alternator output wire from the alternator "B" terminal.
6. Connect a DC ammeter (0 to 150A) in series between the "B" terminal and the disconnected output wire. Connect the (-) lead wire of the ammeter to the disconnected output wire.
7. Attach the engine tachometer and connect the battery ground cable.

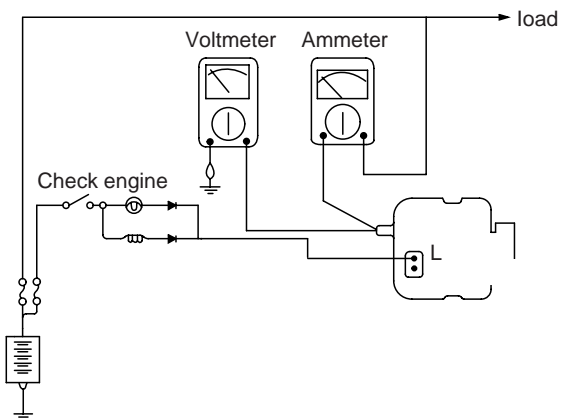

SCMEE6023N

CHARGING SYSTEM

TEST

1. Turn on the ignition switch and check to see that the voltmeter indicates the following value.

Voltage: Battery voltage

If it reads 0V, there is an open circuit in the wire between the alternator "B" terminal and the battery and the battery (-) terminal.

2. Start the engine. Keep all lights and accessories off.
3. Run the engine at a speed of about 2,500 rpm and read the voltmeter when the alternator output current drops to 10A or less

RESULT

1. If the voltmeter reading agrees with the value listed in the regulating voltage table below, the voltage regulator is functioning correctly. If the reading is other than the standard value, the voltage regulator or the alternator is faulty.

REGULATING VOLTAGE TABLE

Voltage regulator ambient temperature °C (°F)	Regulating voltage (V)
-30 (-22)	14.2 ~ 15.3
25 (77)	14.2 ~ 14.8
135 (275)	13.3 ~ 14.8

2. Upon completion of the test, reduce the engine speed to idle, and turn off the ignition switch.
3. Disconnect the battery ground cable.
4. Remove the voltmeter and ammeter and the engine tachometer.
5. Connect the alternator output wire to the alternator "B" terminal.
6. Connect the battery ground cable.

ALTERNATOR

COMPONENTS ECA2A444

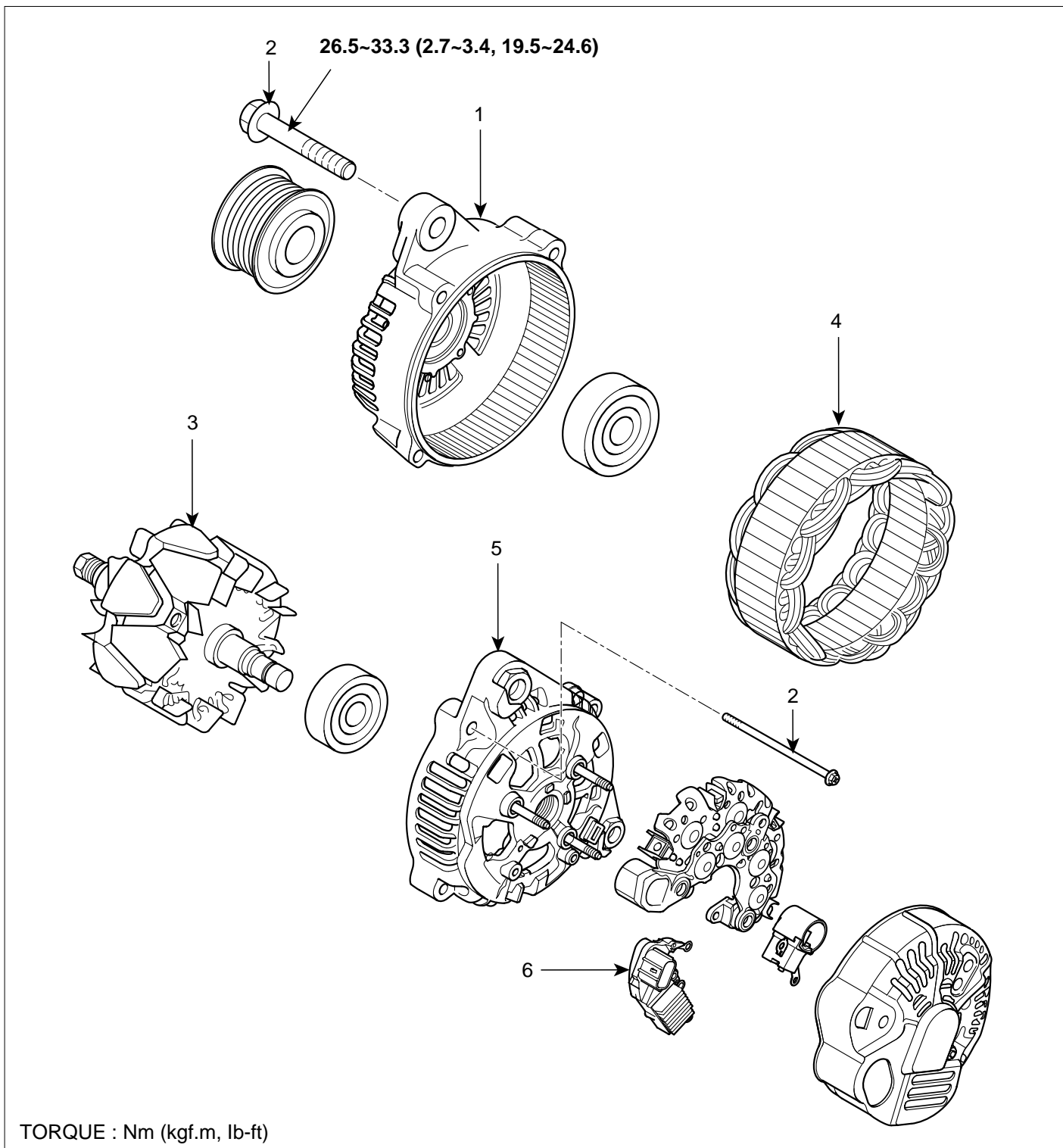

- 1. Generator front frame assembly
- 2. Bolt
- 3. Rotor assembly

- 4. Stator assembly
- 5. Rear bracket assembly
- 6. Regulator assembly

SGHEE7008N

CHARGING SYSTEM

EE -17

REMOVAL E5D43CDB

1. Disconnect the battery negative terminal first, then the positive terminal.
2. Disconnect the alternator connector, and remove the cable from alternator "B" terminal.
3. Remove the drive belt.
4. Pull out the through bolt and then remove the alternator(A).

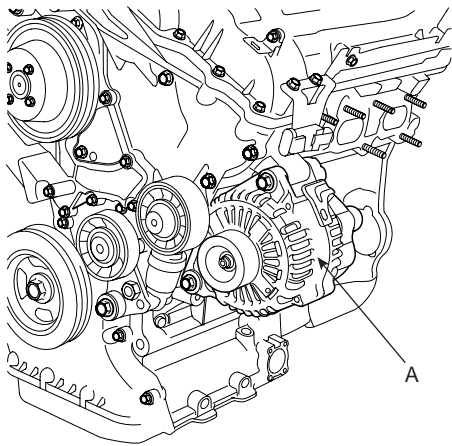

SGHEE7004N

5. Installation is the reverse of removal.

DISASSEMBLY E17973D4

1. If the front bearing needs replacing, remove the pulley with a hexagonal wrench.
2. Remove the generator cover(A) after removing the three nuts(B).

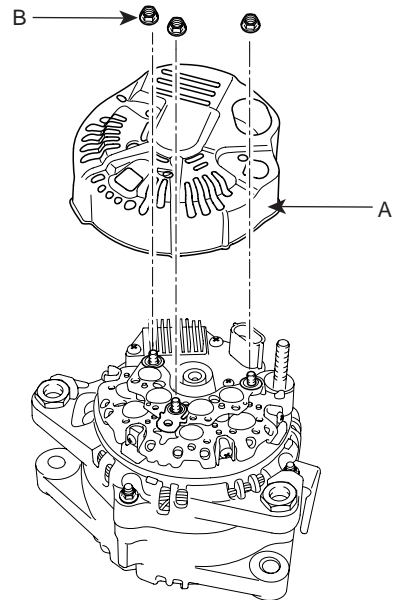

SCMEE6009N

3. Remove the brush holder(A).

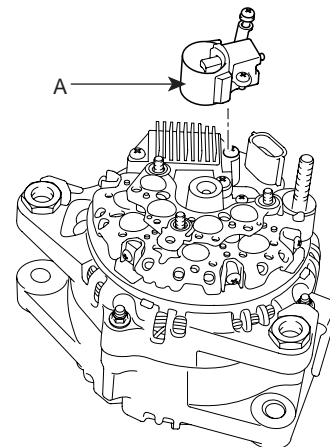

SCMEE6010N

4. Remove the four screws, the rectifier(B) and the rubber seal(C).

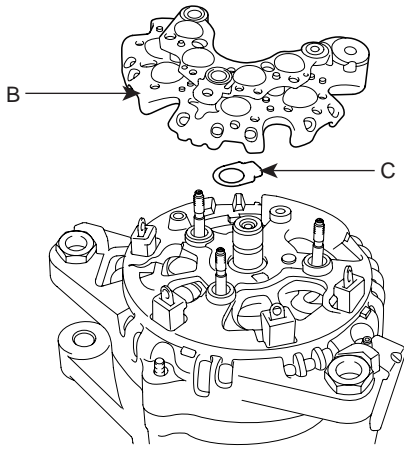

SCMEE6011N

6. Remove the rear bracket assembly(A) and washer(B).

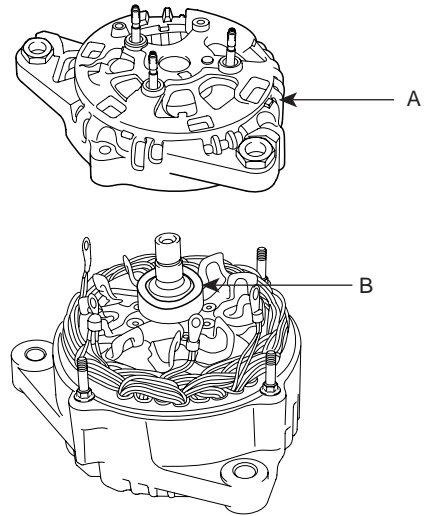

SCMEE6014N

5. Remove the four nuts(A) and insulators(B).

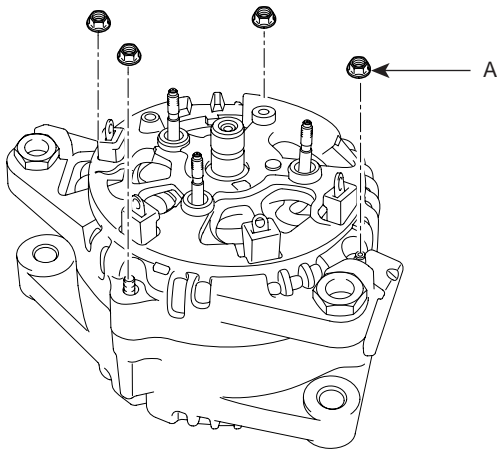

SCMEE6024N

7. Remove the rotor(A) from the stator and front frame assembly(B).

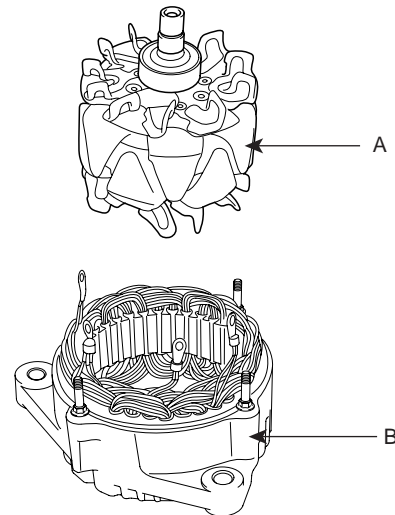

SCMEE6015N

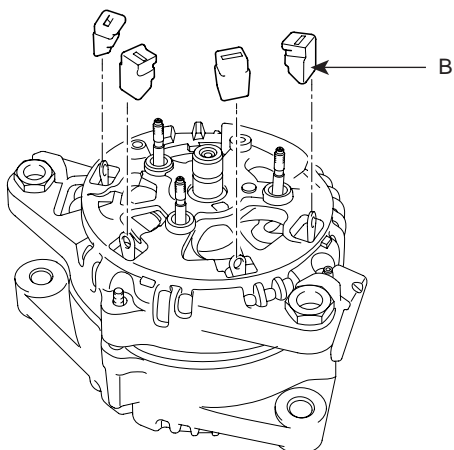

SCMEE6013N

INSPECTION

E2A74301

ROTOR

1. Check that there is continuity between the slip rings(A). If there is no continuity, replace the generator.

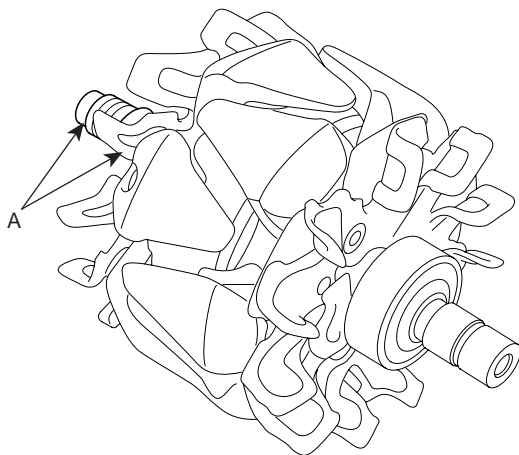

SCMEE6016N

STATOR

1. Check that there is continuity between each pair of leads(A). If there is no continuity, replace the generator.

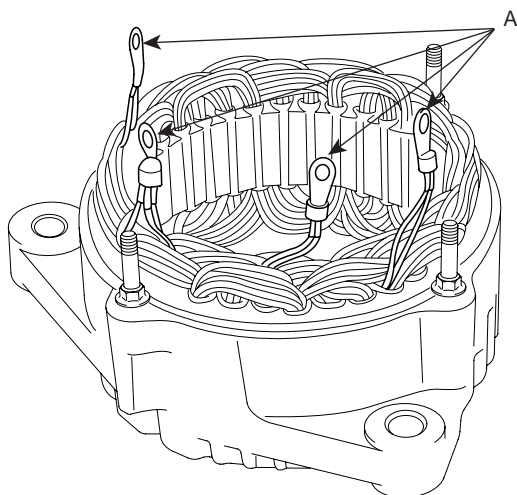

SCMEE6020N

RECTIFIER

1. Check for continuity in each direction, between the B terminal(A) and P terminals(B), between the E terminal(C) and P terminals(B) of each diode pair. All diodes should have continuity in only one direction. Because the rectifier diodes are designed to allow current to pass in one direction, and the rectifier is made up of eight diodes(four pairs), you must test each diode in both directions for continuity with an ohmmeter that has diode checking capability: a total of 16 checks. If any diode failed, replace the rectifier assembly.

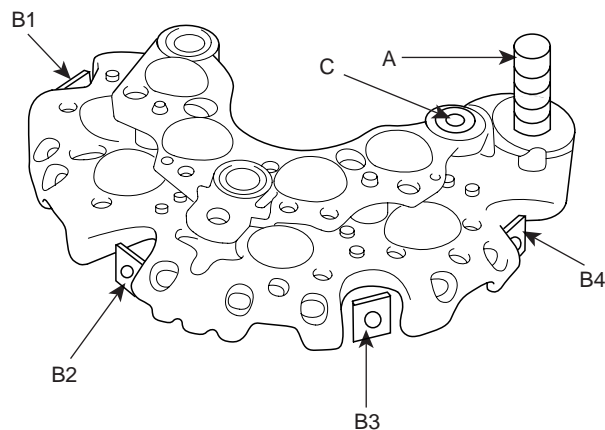

SCMEE6018N

REASSEMBLY EDB38762

NOTE

Be careful not to get any grease or oil on the slip rings.

1. Insert the rotor(A) in the stator and front frame assembly(B).

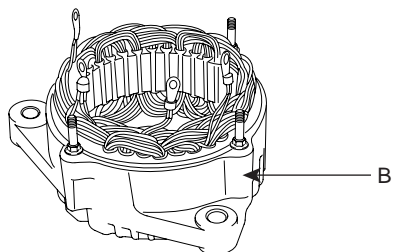
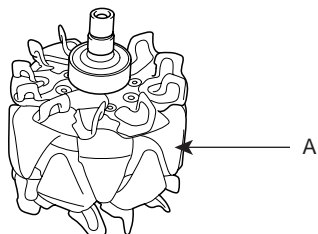

SCMEE6015N

2. Install the washer(B) and the rear bracket assembly(A)

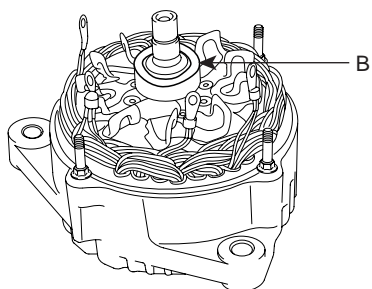
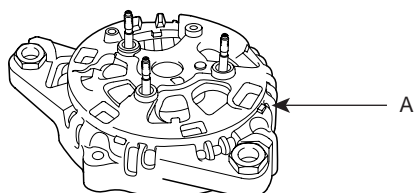

SCMEE6014N

3. Tighten the four nuts and insulators(B).

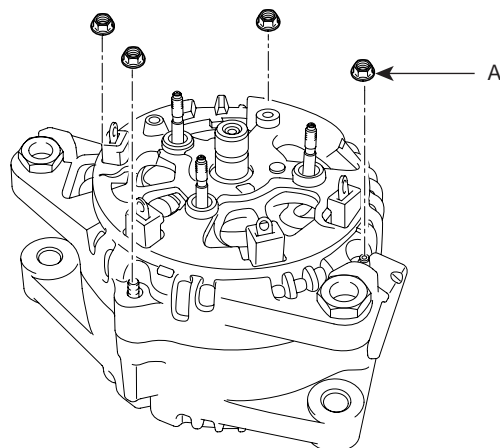

SCMEE6024N

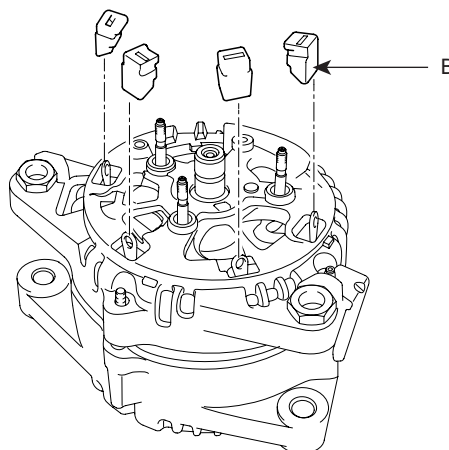

SCMEE6013N

4. Install the rectifier(B) and the rubber seal(C) by tightening the four screws(A),

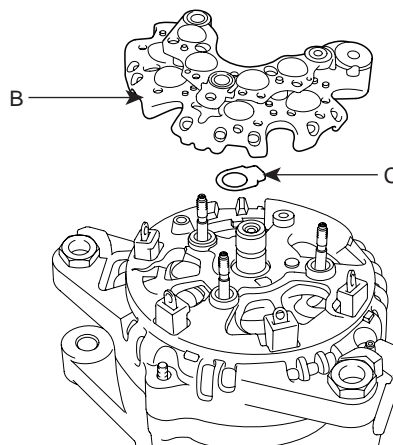

SCMEE6011N

5. Install the brush holder(A).

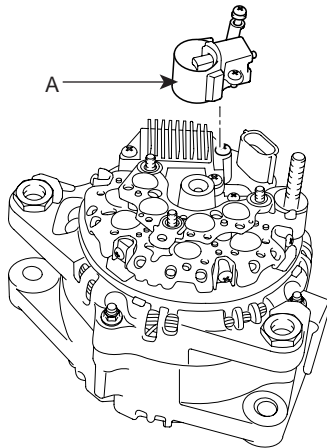

SCMEE6010N

6. Install the generator cover(A) by tightening the three nuts(B).

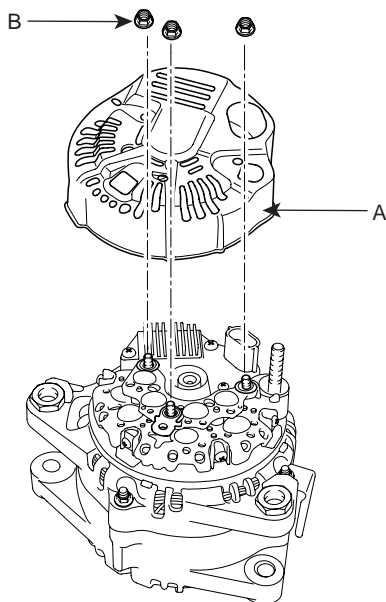

SCMEE6009N

7. Install the pulley with a hexagonal wrench.

BATTERY

DESCRIPTION E7B98282

1. The maintenance-free battery is, as the name implies, totally maintenance free and has no removable battery cell caps.
2. Water never needs to be added to the maintenance-free battery.
3. The battery is completely sealed, except for small vent holes in the cover.

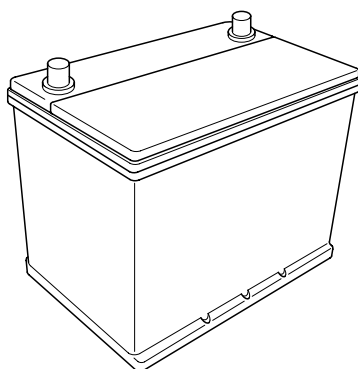

EBJD008A

INSPECTION E2C8137C

BATTERY DIAGNOSTIC FLOW

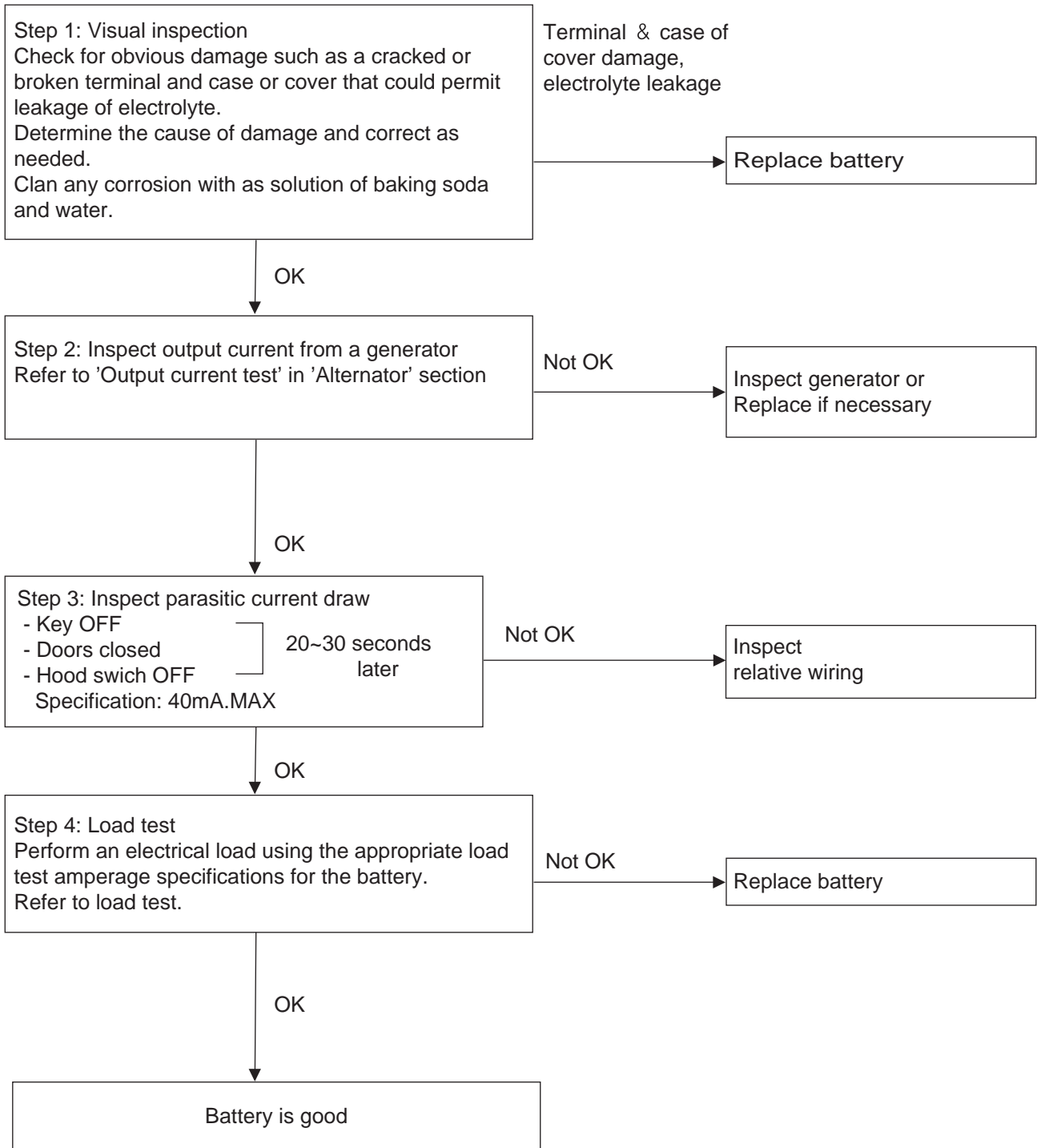

LOAD TEST

1. Perform the following steps to complete the load test procedure for maintenance free batteries.
2. Connect the load tester clamps to the terminals and proceed with the test as follow:
 - 1) If the battery has been on charge, remove the surface charge by connecting a 300ampere load for 15 seconds.
 - 2) Connect the voltmeter and apply the specified load.
 - 3) Read the voltage after the load has been applied for 15 seconds.
 - 4) Disconnect the load.
 - 5) Compare the voltage reading with the minimum and replace the battery if battery test voltage is below that shown in the voltage table.

Voltage	Temperature
9.6V	20°C (68.0°F) and above
9.5V	16°C (60.8°F)
9.4V	10°C (50.0°F)
9.3V	4°C (39.2°F)
9.1V	-1°C (30.2°F)
8.9V	-7°C (19.4°F)
8.7V	-12°C (10.4°F)
8.5V	-18°C (-0.4°F)

NOTE

- If the voltage is greater than shown in the table, the battery is good.
- If the voltage is less than shown in the table, replace the battery.

CLEANING EDF50944

1. Make sure the ignition switch and all accessories are in the OFF position.
2. Disconnect the battery cables (negative first).
3. Remove the battery from the vehicle.

CAUTION

Care should be taken in the event the battery case is cracked or leaking, to protect your skin from the electrolyte. Heavy rubber gloves (not the household type) should be worn when removing the battery.

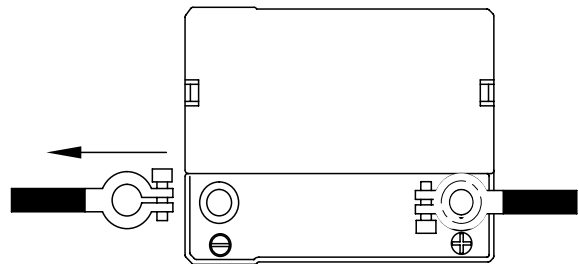

EBJD008B

4. Inspect the battery tray for damage caused by the loss of electrolyte. If acid damage is present, it will be necessary to clean the area with a solution of clean warm water and baking soda. Scrub the area with a stiff brush and wipe off with a cloth moistened with baking soda and water.
5. Clean the top of the battery with the same solution as described above.
6. Inspect the battery case and cover for cracks. If cracks are present, the battery must be replaced.
7. Clean the battery posts with a suitable battery post tool.
8. Clean the inside surface of the terminal clamps with a suitable battery cleaning tool. Replace damaged or frayed cables and broken terminal clamps.
9. Install the battery in the vehicle.
10. Connect the cable terminals to the battery post, making sure tops of the terminals are flush with the tops of the posts.

11. Tighten the terminal nuts securely.
12. Coat all connections with light mineral grease after tightening.

⚠ CAUTION

When batteries are being charged, an explosive gas forms beneath the cover of each cell. Do not smoke near batteries being charged or which have recently been charged. Do not break live circuit at the terminals of batteries being charged. A spark will occur when the circuit is broken. Keep open flames away from battery.

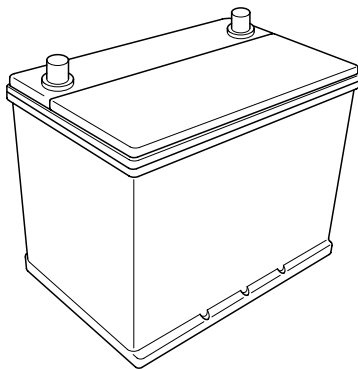

EBJD008A

STARTING SYSTEM

DESCRIPTION EBD6AA2E

The starting system includes the battery, starter, solenoid switch, ignition switch, inhibitor switch (A/T), ignition lock switch, connection wires and the battery cable.

When the ignition key is turned to the start position, current flows and energizes the starter motor's solenoid coil.

The solenoid plunger and clutch shift lever are activated, and the clutch pinion engages the ring gear.

The contacts close and the starter motor cranks. In order to prevent damage caused by excessive rotation of the starter armature when the engine starts, the clutch pinion gear overruns.

TROUBLESHOOTING ED641D7C

STARTER CIRCUIT

NOTE

The battery must be in good condition and fully charged.

1. Remove the fuel pump relay(A) from the fuse box.

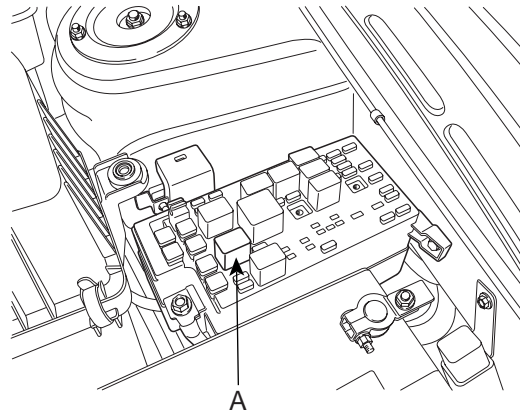

SGHEE7003N

2. With the shift lever in N or P (A/T) or clutch pedal pressed (M/T), turn the ignition switch to "START"

If the starter normally cranks the engine, starting system is OK. If the starter will not crank the engine at all, go to next step.

If it won't disengage from the ring gear when you release key, check for the following until you find the cause.

- Solenoid plunger and switch malfunction.
- Dirty pinion gear or damaged overrunning clutch.

3. Check the battery condition. Check electrical connections at the battery, battery negative cable connected to the body, engine ground cables, and the starter for looseness and corrosion. Then try starting the engine again.

If the starter cranks normally the engine, repairing the loose connection repaired the problem. The starting system is now OK.

If the starter still does not crank the engine, go to next step.

4. Disconnect the connector from the S-terminal of solenoid. Connect a jumper wire from the B-terminal of solenoid to the S-terminal of solenoid.

If the starter cranks the engine, go to next step.
If the starter still does not crank the engine, remove the starter, and repair or replace as necessary.

5. Check the following items in the order listed until you find the open circuit.
 - Check the wire and connectors between the driver's under-dash fuse/relay box and the ignition switch, and between the driver's under-dash fuse/relay box and the starter.
 - Check the ignition switch (Refer to ignition system in BE Group).
 - Check the transaxle range switch connector or ignition lock switch connector.
 - Inspect the starter relay.

STARTER SOLENOID TEST

1. Disconnect the field coil wire from the M-terminal of solenoid switch.
2. Connect the battery as shown. If the starter pinion pops out, it is working properly. To avoid damaging the starter, do not leave the battery connected for more than 10 seconds.

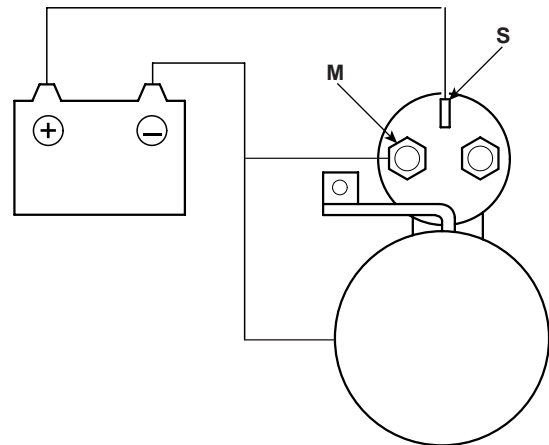

KBSE203D

3. Disconnect the battery from the M terminal. If the pinion does not retract, the hold-in coil is working properly. To avoid damaging the starter, do not leave the battery connected for more than 10 seconds.

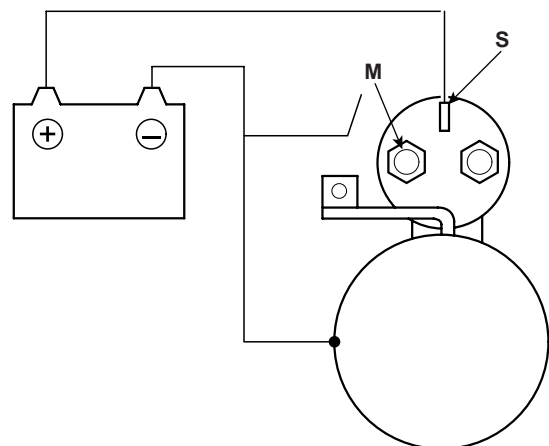

KBSE203E

4. Disconnect the battery also from the body. If the pinion retracts immediately, it is working properly. To avoid damaging the starter, do not leave the battery connected for more than 10 seconds.

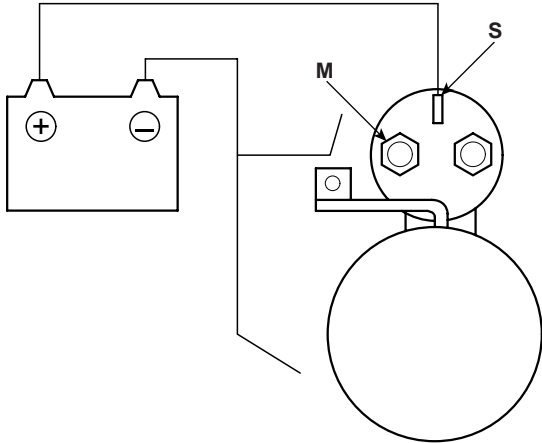

KBSE203F

FREE RUNNING TEST

1. Place the starter motor in a vise equipped with soft jaws and connect a fully-charged 12-volt battery to starter motor as follows.
2. Connect a test ammeter (100-ampere scale) and carbon pile rheostats as shown in the illustration.
3. Connect a voltmeter (15-volt scale) across starter motor.

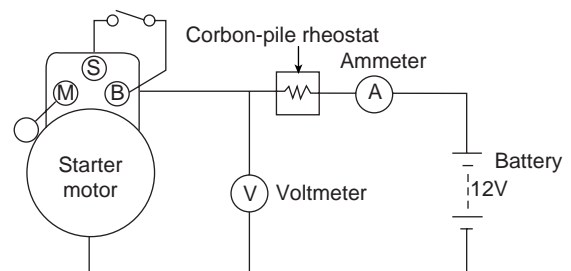

BBGE005A

4. Rotate carbon pile to the off position.
5. Connect the battery cable from battery's negative post to the starter motor body.
6. Adjust until battery voltage shown on the voltmeter reads 11volts.
7. Confirm that the maximum amperage is within the specifications and that the starter motor turns smoothly and freely.

Current : 85A MAX
Speed : 2,600 rpm MIN

STARTER

COMPONENTS E7B5C89E

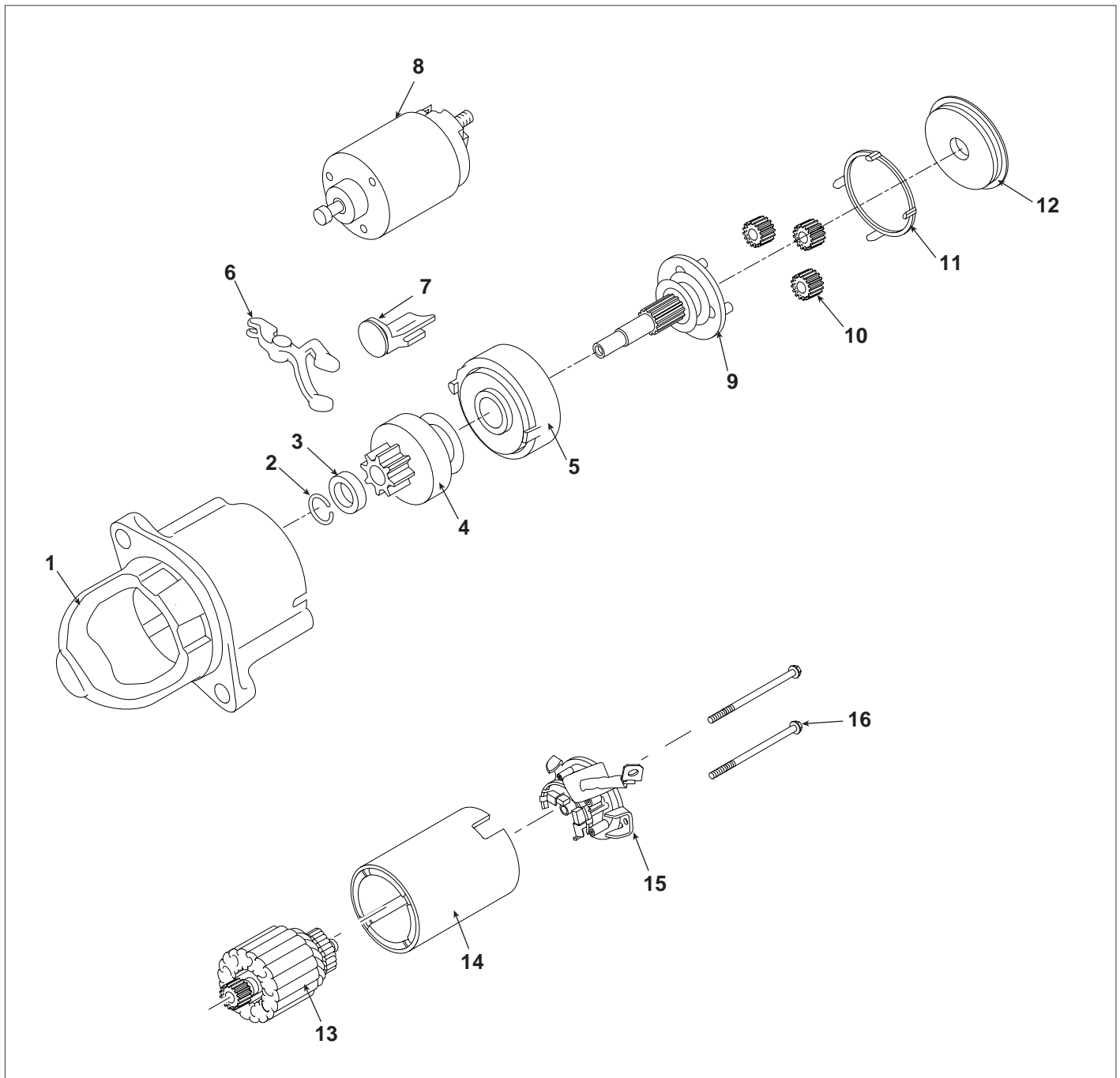

- | | |
|----------------------------|-----------------------------|
| 1. Front bracket | 9. Planet shaft assembly |
| 2. Stop ring | 10. Planetary gear assembly |
| 3. Stopper | 11. Packing |
| 4. Overrun clutch assembly | 12. Shield |
| 5. Internal gear assembly | 13. Armature assembly |
| 6. Lever | 14. Yoke assembly |
| 7. Lever packing | 15. Brush holder assembly |
| 8. Magnet switch assembly | 16. Through bolt |

REMOVAL E62E99CD

1. Disconnect the starter cable from the B terminal on the solenoid, and the connector from the S terminal.
2. Remove the 2 bolts (D) holding the starter, then remove the starter (E).

TROQUE :

49.0 ~ 63.7 Nm (5.0 ~ 6.5 kgf.m, 36.2 ~ 47.0 lb-ft) - starter mounting(D)

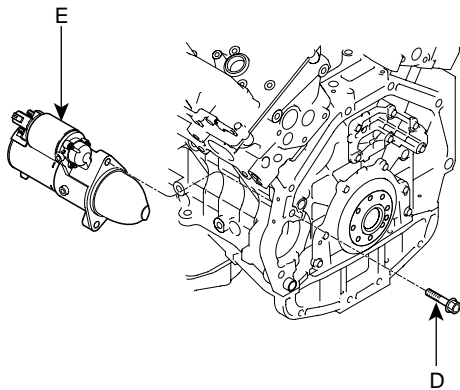

SBLEA6003L

3. Installation is the reverse of removal.
4. Connect the battery negative cable to the battery.

DISASSEMBLY E6F95358

1. Disconnect the M-terminal on the magnet switch assembly.
2. After loosening the 3 screws (A), detach the magnet switch assembly (B).

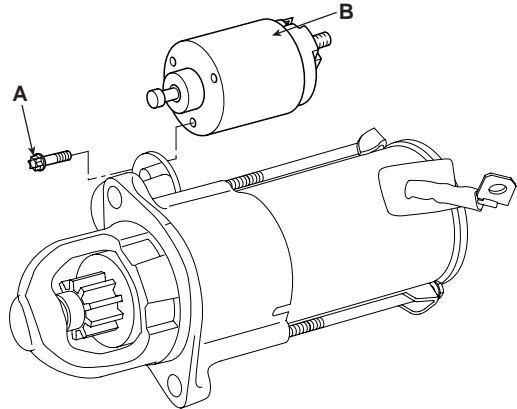

KBRF010A

3. Loosen the through bolts (A).

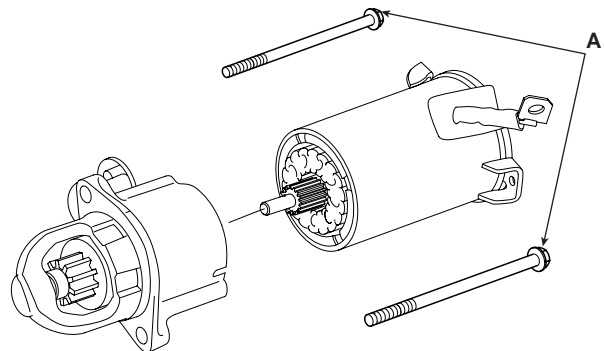

KBRF011A

4. Remove the brush holder assembly (A), yoke (B) and armature (C).

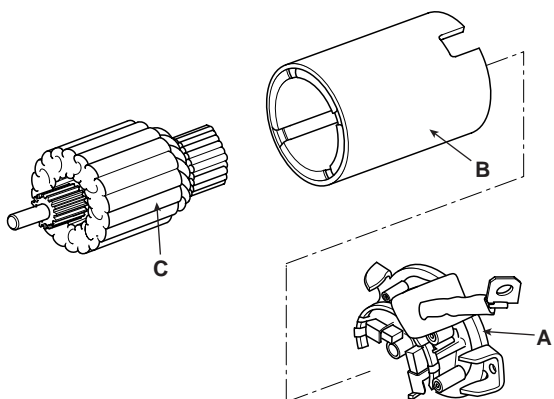

KBRF012A

7. Disconnect the planet gear (A).

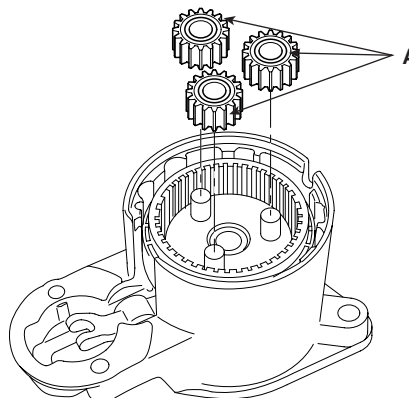

EBKD011I

5. Remove the shield (A) and packing (B).

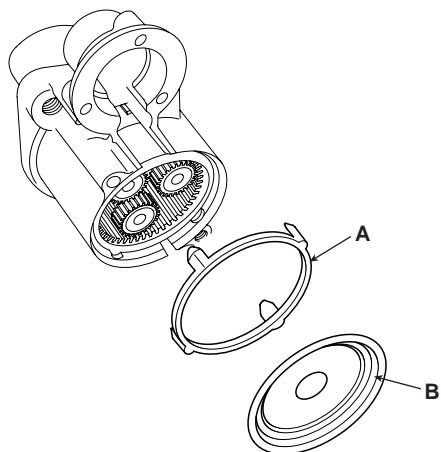

SBLEA6012L

8. Disconnect the planet shaft assembly (A) and lever (B).

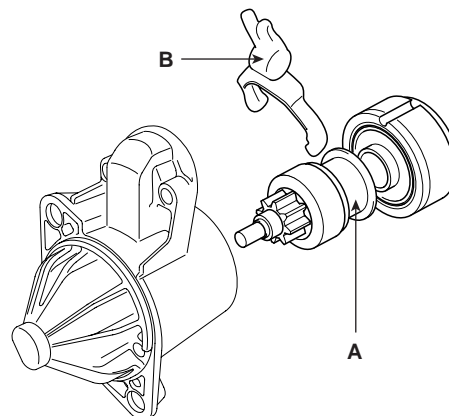

SBLEA6014L

6. Remove the lever plate (A) and lever packing (B).

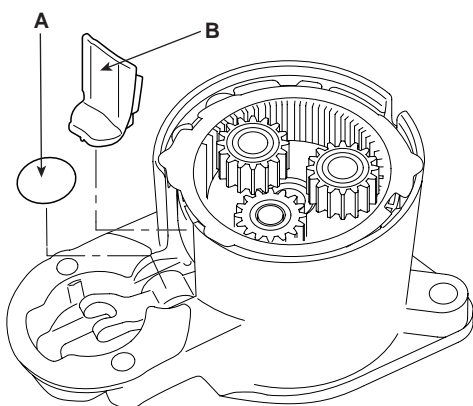

EBKD011H

9. Press the stop ring (A) using a socket (B).

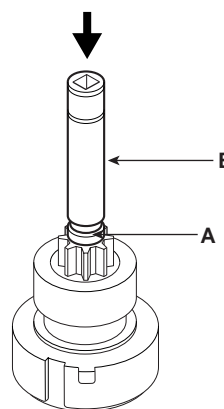

SBLEA6013L

10. After removing the stopper (A) using stopper pliers (B).

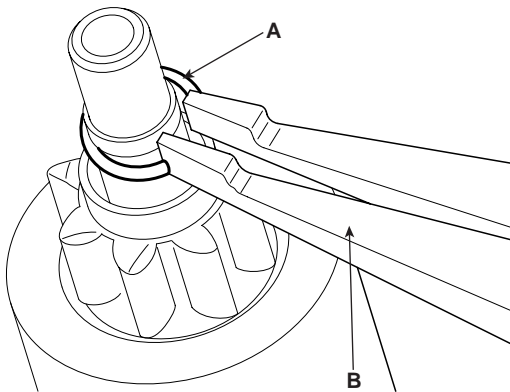

EBKD011L

12. Reassembly is the reverse of disassembly.

 **NOTE**

Using a suitable pulling tool (A), pull the overrunning clutch stop ring (B) over the stopper (C).

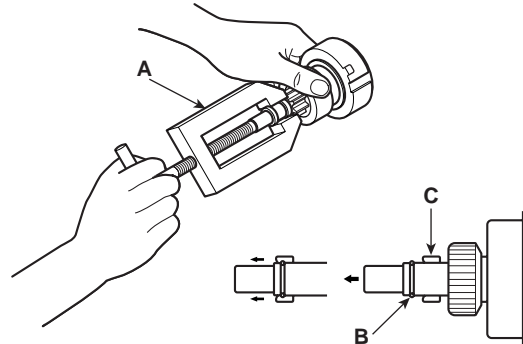

EBKD011O

11. Disconnect the stop ring (A), overrunning clutch (B), internal gear (C) and planet shaft (D).

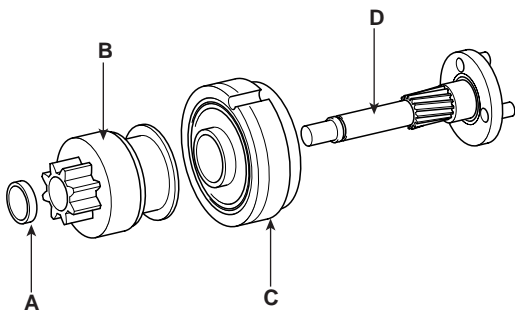

EBKD011M

INSPECTION E2B9216A

ARMATURE

1. Remove the starter.
2. Disassemble the starter as shown at the beginning of this procedure.
3. Inspect the armature for wear or damage from contact with the permanent magnet. If there is wear or damage, replace the armature.

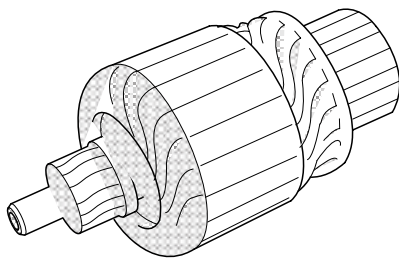

EBKD012A

4. Check the commutator (A) surface. If the surface is dirty or burnt, resurface with emery cloth or a lathe within the following specifications, or recondition with #500 or #600 sandpaper (B).

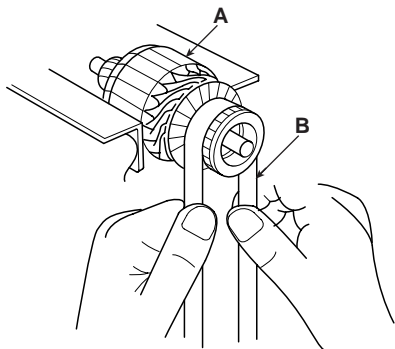

EBKD012B

5. Measure the commutator (A) runout.
 - If the commutator runout is within the service limit, check the commutator for carbon dust or brass chips between the segments.
 - If the commutator run out is not within the service limit, replace the armature.

Commutator runout
Standard (New): 0.02mm (0.0008in.) max
Service limit: 0.05mm (0.0020in.)

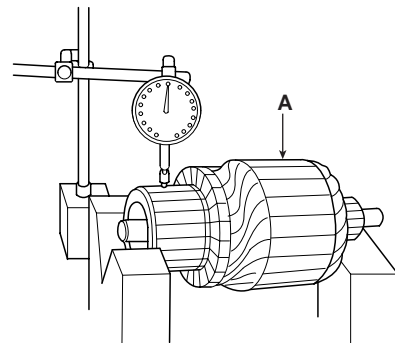

EBKD012D

6. Check the mica depth (A). If the mica is too high (B), undercut the mica with a hacksaw blade to the proper depth. Cut away all the mica (C) between the commutator segments. The undercut should not be too shallow, too narrow, or v-shaped (D).

Commutator mica depth
Standard (New) : 0.5 mm (0.0197 in.)
Limit : 0.2mm (0.0079 in.)

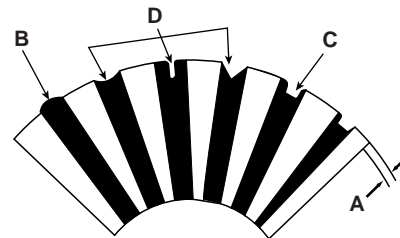

EBKD012E

7. Check for continuity between the segments of the commutator. If an open circuit exists between any segments, replace the armature.

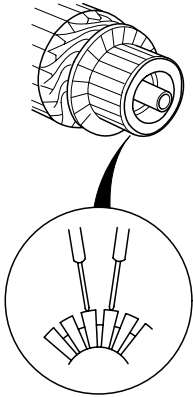

EBKD012F

8. Check with an ohmmeter that no continuity exists between the commutator (A) and armature coil core (B), and between the commutator and armature shaft (C). If continuity exists, replace the armature.

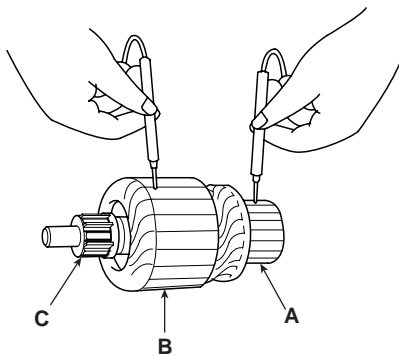

EBKD012G

STARTER BRUSH

Brushes that are worn out, or oil-soaked, should be replaced.

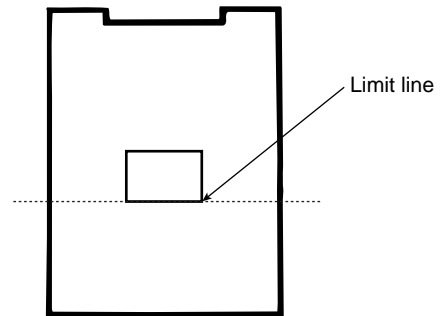

EBRF022A

STARTER BRUSH HOLDER

1. Check that there is no continuity between the (+) brush holder (A) and (-) brush holder (B). If there is no continuity, replace the brush holder assembly.

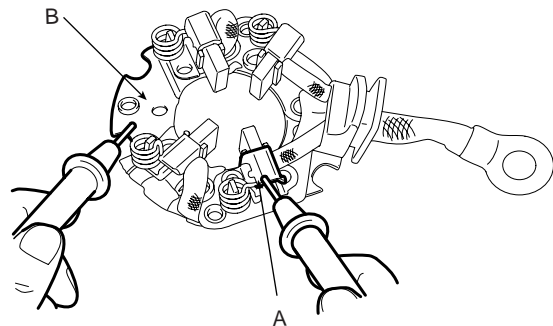

EBBD330A

2. Pry back each brush spring (A) with a screwdriver, then position the brush (B) about halfway out of its holder, and release the spring to hold it there.

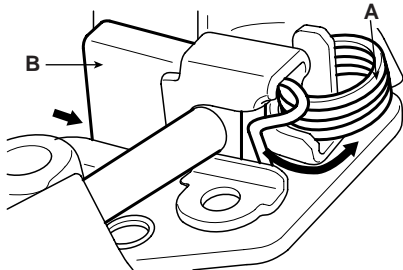

EBKD012K

3. Install the armature in the housing, and install the brush holder. Next, pry back each brush spring again, and push the brush down until it seats against the commutator, then release the spring against the end of the brush.

NOTE

To seat new brushes, slip a strip of #500 or #600 sandpaper, with the grit side up, between the commutator and each brush, and smoothly rotate the armature. The contact surface of the brushes will be sanded to the same contour as the commutator.

OVERRUNNING CLUTCH

1. Slide the overrunning clutch along the shaft. Replace it if it does not slide smoothly.
2. Rotate the overrunning clutch both ways. Does it lock in one direction and rotate smoothly in reverse? If it does not lock in either direction or it locks in both directions, replace it.

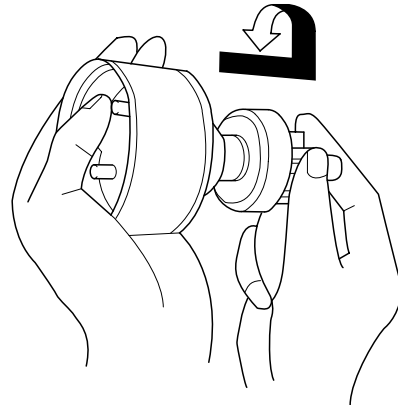

EBKD012J

3. If the starter drive gear is worn or damaged, replace the overrunning clutch assembly. (the gear is not available separately). Check the condition of the flywheel or torque converter ring gear if the starter drive gear teeth are damaged.

CLEANING E936CE3C

1. Do not immerse parts in cleaning solvent. Immersing the yoke assembly and/or armature will damage the insulation. Wipe these parts with a cloth only.
2. Do not immerse the drive unit in cleaning solvent. The overrun clutch is pre-lubricated at the factory and solvent will wash lubrication from the clutch.
3. The drive unit may be cleaned with a brush moistened with cleaning solvent and wiped dry with a cloth.

STARTER RELAY

INSPECTION E3FF7813

1. Remove the fuse box cover.
2. Remove the starter relay (A).

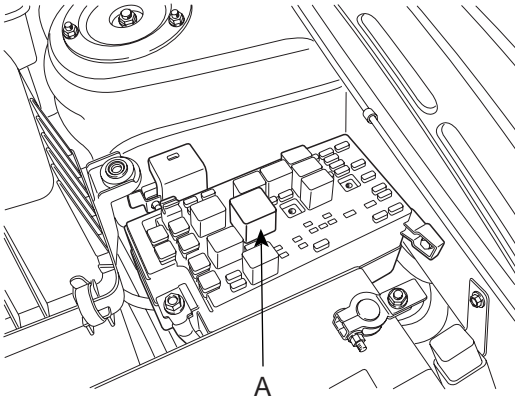

SGHEE7005N

3. Using an ohmmeter, check that there is continuity between each terminal.

Terminal	Continuity
30 - 87	NO
85 - 86	YES

4. Apply 12V to terminal 85 and ground to terminal 86. Check for continuity between terminals 30 and 87.

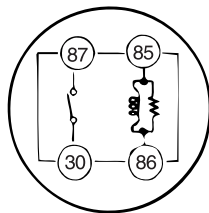
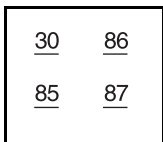

LDAD510B

5. If there is no continuity, replace the starter relay.
6. Install the starter relay.
7. Install the fuse box cover.

CRUISE CONTROL SYSTEM

TROUBLE SYMPTOM CHARTS E0B03761

TROUBLE SYMPTOM 1

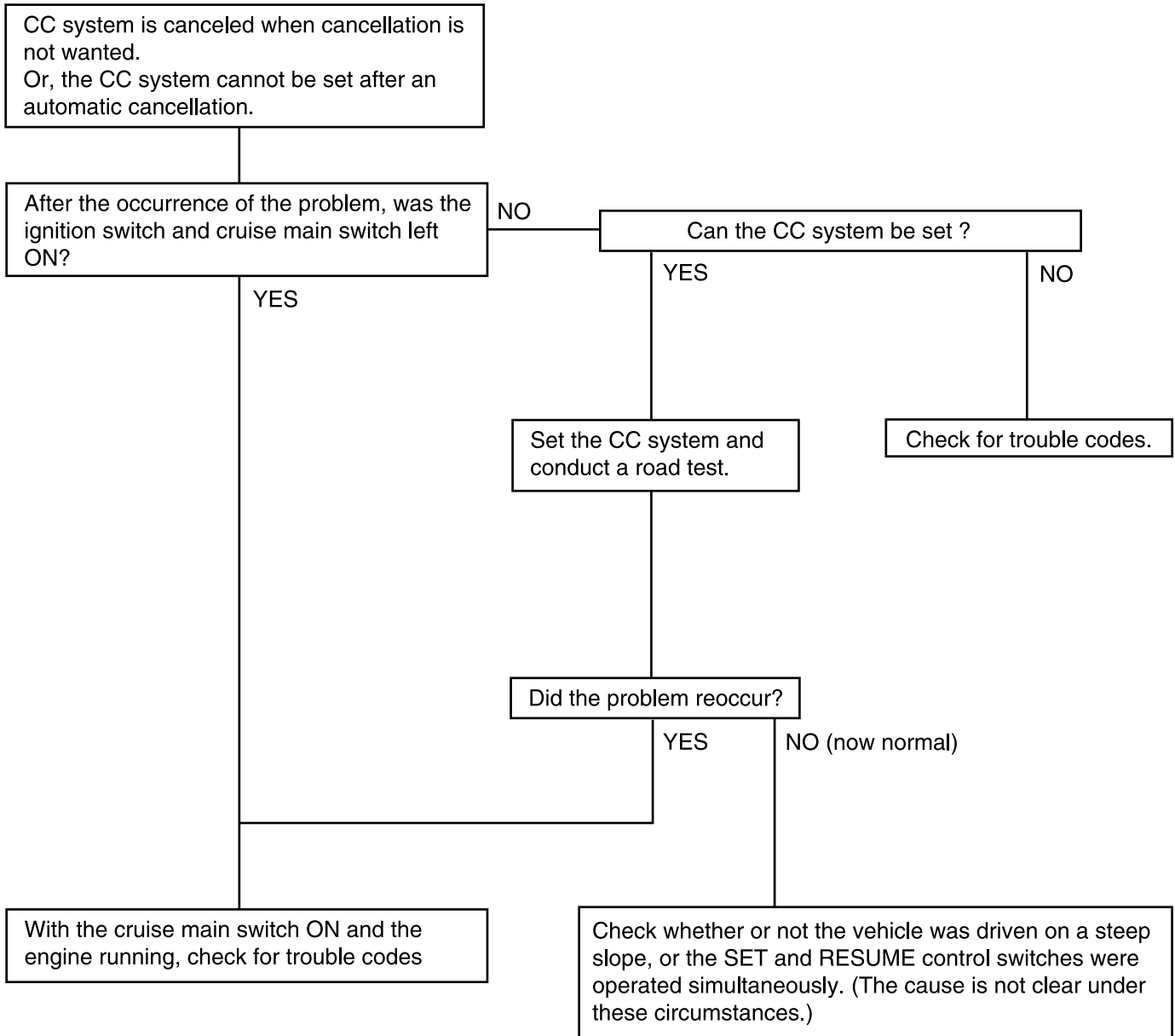

CC : Cruise Control
ECM: Engine Control Module

SCMEE6006N

TROUBLE SYMPTOM 2

Trouble symptom	Probable cause	Remedy
The set vehicle speed varies greatly upward or downward "Surging" (repeated alternating acceleration and deceleration) occurs after setting	Malfunction of the vehicle speed sensor circuit	Repair the vehicle speed sensor system, or replace the part
	Malfunction of PCM	Check input and output signals at PCM

TROUBLE SYMPTOM 3

Trouble symptom	Probable cause	Remedy
The CC system is not canceled when the brake pedal is depressed	Damaged or disconnected wiring of the brake pedal switch	Repair the harness or replace the brake pedal switch
	Malfunction of the PCM signals	Check input and output signals at PCM

TROUBLE SYMPTOM 4

Trouble symptom	Probable cause	Remedy
The CC system is not canceled when the shift lever is moved to the "N" position (It is canceled, however, when the brake pedal is depressed)	Damaged or disconnected wiring of inhibitor switch input circuit	Repair the harness or repair or replace the inhibitor switch
	Improper adjustment of inhibitor switch	
	Malfunction of the PCM signals	Check input and output signals at PCM

TROUBLE SYMPTOM 5

Trouble symptom	Probable cause	Remedy
Cannot decelerate (coast) by using the SET switch	Temporary damaged or disconnected wiring of SET switch input circuit	Repair the harness or replace the SET switch
	Malfunction of the PCM signals	Check input and output signals at PCM

TROUBLE SYMPTOM 6

Trouble symptom	Probable cause	Remedy
Cannot accelerate or resume speed by using the RESUME switch	Damaged or disconnected wiring, or short circuit, or RESUME switch input circuit	Repair the harness or replace the RESUME switch
	Malfunction of the PCM signals	Check input and output signals at PCM

TROUBLE SYMPTOM 7

Trouble symptom	Probable cause	Remedy
CC system can be set while driving at a vehicle speed of less than 40km/h (25mph), or there is no automatic cancellation at that speed	Malfunction of the vehicle-speed sensor circuit	Repair the vehicle speed sensor system, or replace the part
	Malfunction of the PCM signals	Check input and output signals at PCM

TROUBLE SYMPTOM 8

Trouble symptom	Probable cause	Remedy
The cruise main switch indicator lamp does not illuminate (But CC system is normal)	Damaged or disconnected bulb of cruise main switch indicator lamp	Repair the harness or replace the part.
	Harness damaged or disconnected	

SYSTEM BLOCK DIAGRAM

E0B505AA

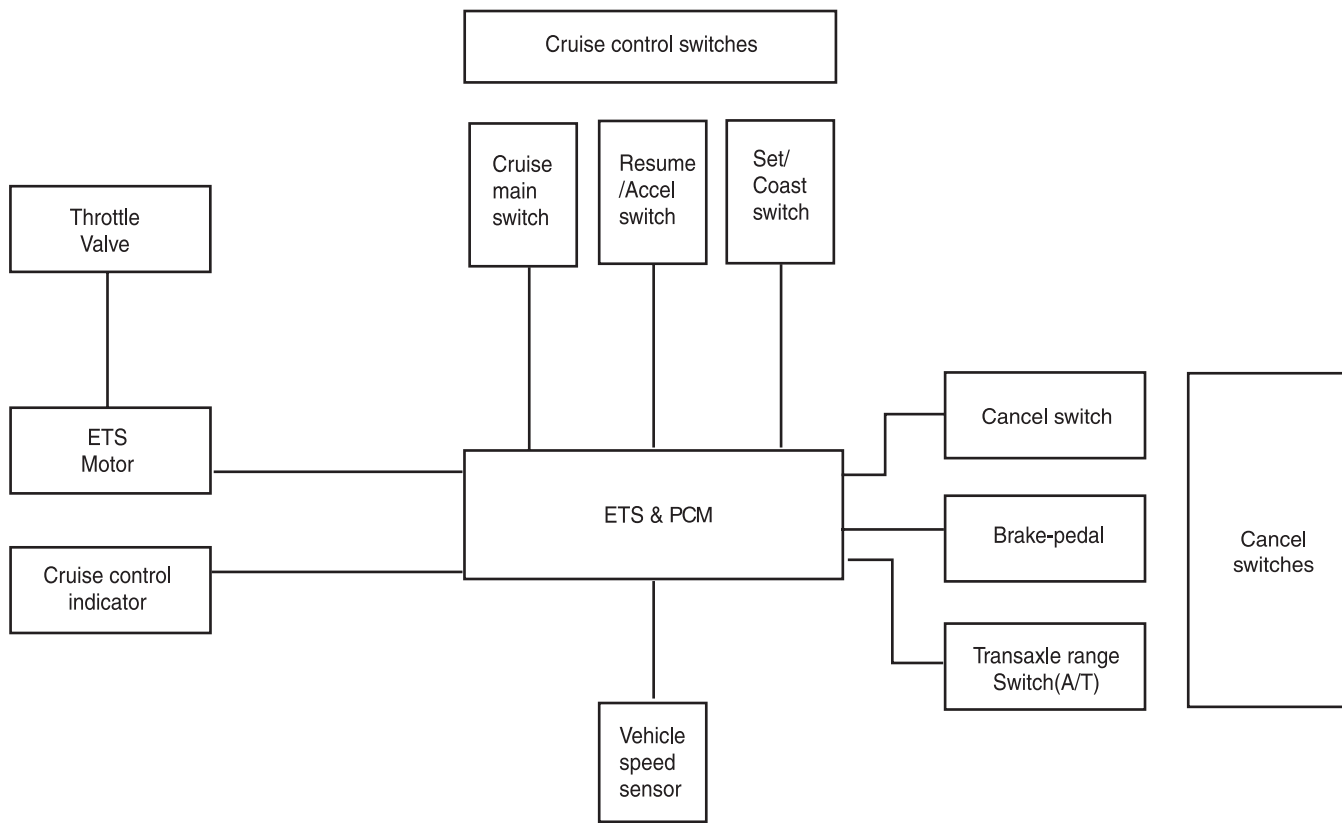

SGHEE7010N

COMPONENT PARTS AND FUNCTION OUTLINE

Component part		Function
Vehicle-speed sensor		Converts vehicle speed to pulse.
Power control module (PCM)		Receives signals from sensor and control switches;
Cruise control indicator		Illuminate when CRUISE main switch is ON (Built into cluster)
Cruise Control switches	CRUISE main switch	Switch for automatic speed control power supply.
	Resume/Accel switch	Controls automatic speed control functions by Resume/Accel switch (Set/Coast switch)
	Set/Coast switch	
Cancel switch	Cancel switch	Sends cancel signals to PCM
	Brake-pedal switch	
	Transaxle range switch (A/T)	
	Clutch switch (M/T)	
ETS motor		Regulates the throttle valve to the set opening by PCM.

* ETS : Electronic Throttle System

CRUISE CONTROL

Cruise control system is engaged by "ON/OFF" main switch located on right of steering wheel column. System has the capability to cruise, coast, resume speed, and accelerate, and raise "tab-up" or lower "tab-down" set speed.

It also has a safety interrupt, engaged upon depressing brake or shifting select lever.

PCM is a speed control system that maintains a required vehicle speed at normal driving conditions.

The main components of cruise control system are mode control switches, transaxle range switch, brake switch, vehicle speed sensor, ECM and ETS motor that connect throttle body.

PCM contains a low speed limit which will prevent system engagement below a minimum speed of 40km/h (25mph). The operation of the controller is controlled by mode control switches located on steering wheel.

Transaxle range switch and brake switch are provided to disengage the cruise control system. The switches are on brake pedal bracket and transaxle. When the brake pedal is depressed or select lever shifted, the cruise control system is electrically disengaged and the throttle is returned to the idle position.

Cruise main switch

Cruise control system is engaged by pressing "ON/OFF" push button. Releasing "ON/OFF" push button release throttle, clears cruise memory speed, and puts vehicle in a non-cruise mode.

Coast/Set switch

COAST/SET switch located on right of steering wheel column has two positions - "Normal" and "Depressed". The set position - With COAST/SET switch depressed and then released the cruise speed will be set at the speed the vehicle was going when COAST/SET switch was released. The coast position - With COAST/SET switch fully depressed, driver can lower cruise speed. To decrease cruise speed, COAST/SET switch is held in, disengaging cruise control system. When vehicle has slowed to required cruise speed, releasing COAST/SET switch will re-engage system at new selected speed.

The tab down - To lower vehicle speed, cruise must be engaged and operating. Tab down is done by quickly pressing and releasing COAST/SET switch. Do not hold COAST/SET switch in depressed position.

Tab down is a function in which vehicle speed is decrease by 1 mph (1.6km/h)

Resume/Accel switch

RES/ACCEL switch located on right of steering wheel column has two positions - "Normal" and "Depressed".

The resume position - With RES/ACCEL switch depressed and then release, this switch also returns cruise control operation to last speed (Which is temporarily disengaged by Cancel switch or Brake pedal), setting when momentarily operating RES/ACCEL switch by constant acceleration.

The accel position - With RES/ACCEL switch depressed and held in, disengaging cruise control system, when vehicle has accelerated to required cruise speed, releasing RES/ACCEL switch will re-engage speed at new selected speed.

The tab up - To increase vehicle speed, the cruise must be engaged and operating.

Tab up is done by quickly pressing and releasing RES/ACCEL switch less than 0.5 second. Do not hold RES/ACCEL switch in depressed position. Tab up is a function in which cruise speed can be increased by 1mph (1.6km/h).

Cancel switch

Cruise control system is temporarily disengaged by pressing "CANCEL" switch.

Cruise speed canceled by this switch will be recovered by RES/ACCEL switch

DTC P0564 CRUISE CONTROL MULTI-FUNCTION INPUT "A" CIRCUIT

COMPONENT LOCATION E9DC6E9D

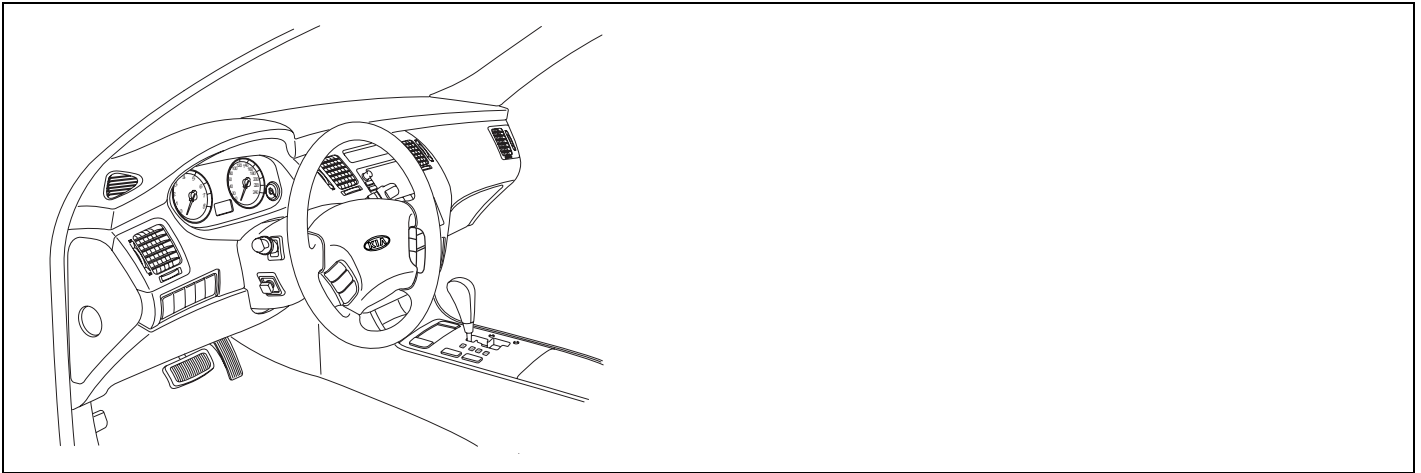

SGHEE7200L

GENERAL DESCRIPTION E79BA8FE

The cruise control system keeps the vehicle running at a fixed speed until a signal canceling this fixed speed is received. When the main switch is turned on with vehicle in the running mode, the battery voltage is applied to the PCM. When a signal from the control switch is input to the PCM while the vehicle is in state, the PCM controls the ETS motor to make a car go at a steady speed you want. Also, while the system is operating, "CRUISE" indicator lamp in the meter assembly lights up.

DTC DESCRIPTION E92229EA

If the switch signal's voltage is not within the calibrated ranges when PCM checks the switch signal under detecting condition, PCM sets P0564.

DTC DETECTING CONDITION EF99DEC9

Item	Detecting Condition	Possible Cause
DTC Strategy	<ul style="list-style-type: none">Monitors the status of the invalid input when the input voltage is converted to the switch input signals.	<ul style="list-style-type: none">Poor connectionOpen or short in cruise switch circuitFaulty cruise switchFaulty PCM
Enable Conditions	<ul style="list-style-type: none">Engine is runningIgnition voltage 9VCruise control system type is learned	
Threshold Value	<ul style="list-style-type: none">Invalid switch signal is monitored	
Diagnosis Time	<ul style="list-style-type: none">More than 7.8 seconds failure for 9.36 seconds test	
MIL On Condition	<ul style="list-style-type: none">NO MIL ON(DTC only)	

SPECIFICATION E9B345FA

Item	Resistance()
ON/OFF switch	3.9 k \pm 5 %
SET switch	220 \pm 5%
RESUME switch	910 \pm 5%
CANCEL switch	0 \pm 5%

SCHEMATIC DIAGRAM

ECF8EAF8

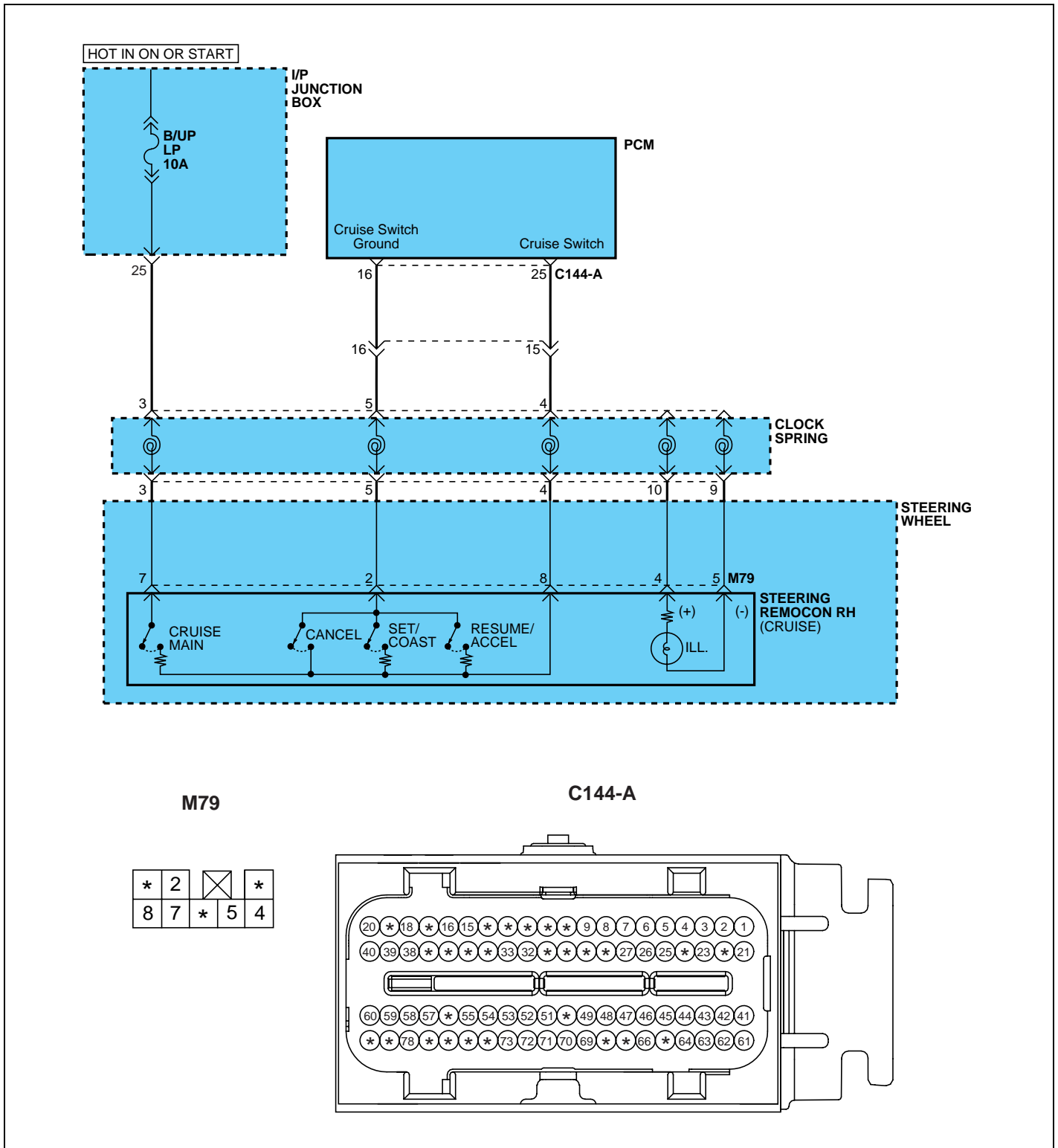

MONITOR DTC STATUS E8E4609A

1. Connect scantool to Data Link Connector(DLC).
2. IG "ON".
3. Select "Diagnostic Trouble Codes(DTCs)" mode, and then Press F5(INFO) to check DTC's information from the DTCs menu.
4. Read "DTC Status" parameter.

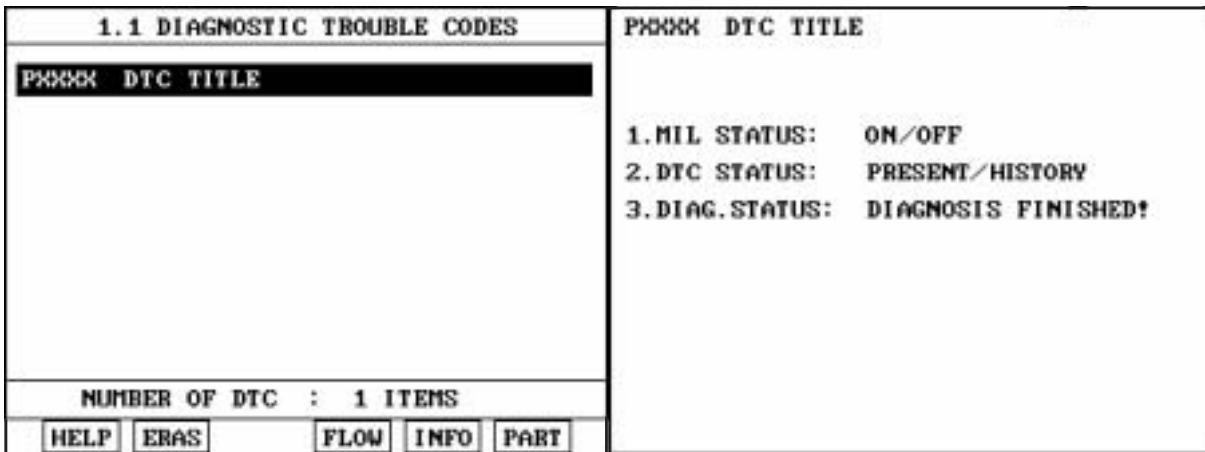

SGHEE7202L

5. Is parameter displayed "Present fault"?

YES

Go to "Terminal and Connector inspection" procedure.

NO

Fault is intermittent caused by poor contact in the sensor's and/ or PCM's connector or was repaired and PCM memory was not cleared.

Thoroughly check connectors for looseness, poor connection, bending, corrosion, contamination, deterioration, or damage. Repair or replace as necessary and go to "Verification of vehicle Repair" procedure.

TERMINAL AND CONNECTOR INSPECTION EBF25B8D

1. Many malfunctions in the electrical system are caused by poor harness and terminals. Faults can also be caused by interference from other electrical systems, and mechanical or chemical damage.
2. Thoroughly check connectors for looseness, poor connection, bending, corrosion, contamination, deterioration, or damage.
3. Has a problem been found?

YES

Repair as necessary and go to "Verification of Vehicle Repair" procedure .

NO

Go to " Power Circuit Inspection " procedure.

POWER CIRCUIT INSPECTION

EA4DDC9D

1. IG "OFF" and disconnect Cruise remocon connector.
2. IG "ON" and ENG "OFF".
3. Measure voltage between terminal 7 of Cruise remocon harness connector and chassis ground.

Specification : Approx. B+

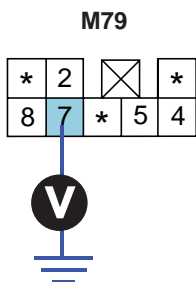

- 2.Ground
- 7.Power supply
- 8.Cruise switch signal

SGHEE7203L

4. Is the measured voltage within specification?

YES

Go to "Signal Circuit Inspection" procedure.

NO

Repair open or short to ground in harness, and go to "Verification of Vehicle Repair" procedure.

SIGNAL CIRCUIT INSPECTION

EC0B2F99

1. Check voltage.
 - 1) IG "OFF" and disconnect Cruise remocon connector.
 - 2) IG "ON" and ENG "OFF".
 - 3) Measure voltage between terminal 8 of Cruise remocon harness connector and chassis ground.

Specification : Approx. 5V

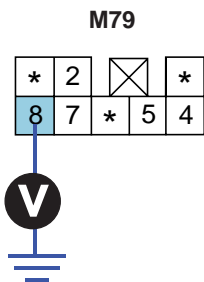

- 2.Ground
- 7.Power supply
- 8.Cruise switch signal

SGHEE7204L

4) Is the measured voltage within specification?

YES

Go to "Component Inspection" procedure.

NO

Go to "Check short in harness" as follows.

2. Check short in harness.

- 1) IG "OFF" and disconnect Cruise remote connector and PCM connector.
- 2) Measure resistance between terminals 8 and 7 of Cruise remote harness connector.
- 3) Measure resistance between terminals 8 and 2 of Cruise remote harness connector.

Specification : Infinite

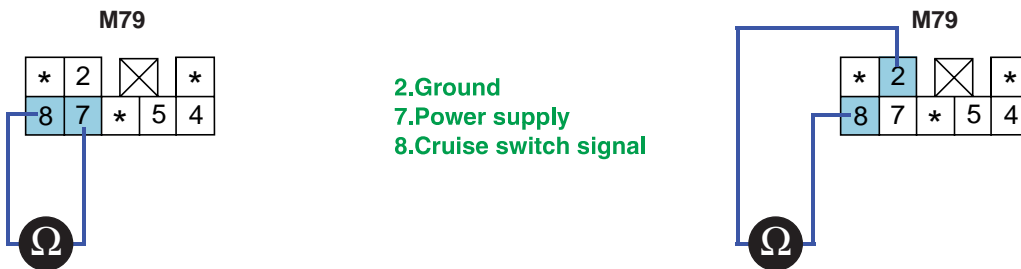

SGHEE7205L

4) Is the measured resistance within specification?

YES

Go to "Check open in harness" as follows.

NO

Repair short in harness, and go to "Verification of Vehicle Repair" procedure.

COMPONENT INSPECTION EFA4D08B

1. Check auto cruise switch.
 - 1) IG "OFF" and disconnect Cruise remocon connector.
 - 2) Measure resistance between terminals 8 and 7 of Cruise remocon connector with each switch depressed.(Component side).
 - 3) Measure resistance between terminals 8 and 2 of Cruise remocon connector with each switch depressed.(Component side).

Specification :

Item	Resistance()
ON/OFF switch	3.9 k ± 5% between terminals 8 and 7
SET switch	220 ± 5% between terminals 8 and 2
RESUME switch	910 ± 5% between terminals 8 and 2
CANCEL switch	0 ± 5% between terminals 8 and 2

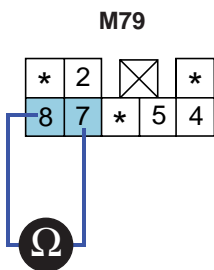

2.Ground
7.Power supply
8.Cruise switch signal

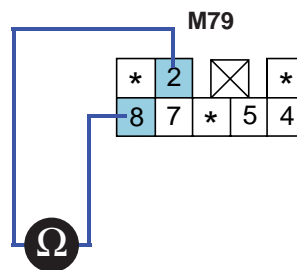

SGHEE7205L

- 4) Is the measured resistance within specification?

YES

Substitute with a known - good PCM and check for proper operation.
If the problem is corrected, replace PCM and go to "Verification of Vehicle Repair" procedure.

NO

Substitute with a known - good auto cruise switch and check for proper operation.
If the problem is corrected, replace auto cruise switch and go to "Verification of Vehicle Repair" procedure.

NOTE

There is a memory reset function on scantool that can erase optional parts automatically detected and memorized by PCM.
After testing PCM on the vehicle, use this function to reuse the PCM on the others.

VERIFICATION OF VEHICLE REPAIR ED9D201B

1. Connect scan tool and select "Diagnostic Trouble Codes(DTCs)" mode.
2. Press F5(INFO) and confirm that "DTC Readiness Flag" indicates "Complete". If not, drive the vehicle within conditions noted in the freeze frame data or enable conditions.
3. Read "DTC Status" parameter.
4. Is parameter displayed "History(Not Present) fault"?

YES

System performing to specification at this time. Clear the DTC.

NO

Go to the applicable troubleshooting procedure.

DTC P0565 CRUISE CONTROL "ON" SIGNAL

COMPONENT LOCATION EFE096B0

Refer to DTC P0564.

GENERAL DESCRIPTION E51F2B44

Refer to DTC P0564.

DTC DESCRIPTION EDE7D1D7

If the main switch signal is switching too frequently or stuck for too long, PCM sets P0565.

DTC DETECTING CONDITION ED4F12AC

Item	Detecting Condition	Possible Cause
DTC Strategy	<ul style="list-style-type: none">Monitors the switch is switching too frequently or stuck for too long.	<ul style="list-style-type: none">Poor connectionFaulty cruise switchFaulty PCM
Enable Conditions	<ul style="list-style-type: none">Engine is runningIgnition voltage 9VCruise control system type is learned	
Threshold Value	<ul style="list-style-type: none">Input switch signal is switching too frequently or stuck	
Diagnosis Time	<ul style="list-style-type: none">Switching: more than 1 second failure for 300 seconds testStuck: more than 75 seconds failure for 300 seconds test	
MIL On Condition	<ul style="list-style-type: none">NO MIL ON(DTC only)	

SPECIFICATION E1A44FB2

Refer to DTC P0564.

SCHEMATIC DIAGRAM E823B53D

Refer to DTC P0564.

MONITOR DTC STATUS EBA88B98

Refer to DTC P0564.

TERMINAL AND CONNECTOR INSPECTION ECB69CE8

1. Many malfunctions in the electrical system are caused by poor harness and terminals. Faults can also be caused by interference from other electrical systems, and mechanical or chemical damage.
2. Thoroughly check connectors for looseness, poor connection, bending, corrosion, contamination, deterioration, or damage.
3. Has a problem been found?

YES

Repair as necessary and go to "Verification of Vehicle Repair" procedure.

NO

Go to " Component Inspection" procedure.

COMPONENT INSPECTION EFCA6FA0

1. Check auto cruise switch.
 - 1) IG "OFF" and disconnect Cruise remocon connector.
 - 2) Measure resistance between terminals 7 and 8 of Cruise remocon connector with "ON" switch depressed.(Component side).

Specification :

Item	Resistance()
ON/OFF switch	3.9 k ± 5% between terminals 7 and 8

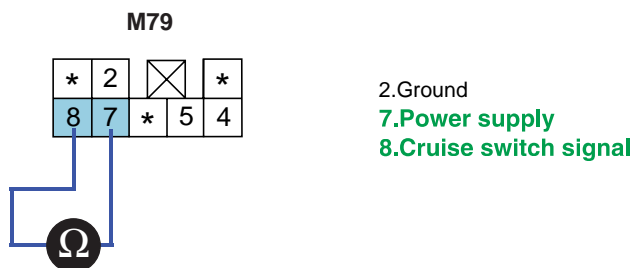

SGHEE7207L

3) Is the measured resistance within specification?

YES

Substitute with a known - good PCM and check for proper operation.
If the problem is corrected, replace PCM and go to "Verification of Vehicle Repair" procedure.

NO

Substitute with a known - good auto cruise switch and check for proper operation.
If the problem is corrected, replace auto cruise switch and go to "Verification of Vehicle Repair" procedure.

 **NOTE**

There is a memory reset function on scantool that can erase optional parts automatically detected and memorized by PCM.

After testing PCM on the vehicle, use this function to reuse the PCM on the others.

VERIFICATION OF VEHICLE REPAIR EBDB132F

Refer to DTC P0564.

DTC P0566 CRUISE CONTROL "CANCEL" SIGNAL

COMPONENT LOCATION EF65F096

Refer to DTC P0564.

GENERAL DESCRIPTION ECFA5BE7

Refer to DTC P0564.

DTC DESCRIPTION E56F5ED5

If the cancel switch signal is switching too frequently or stuck for too long, PCM sets P0566.

DTC DETECTING CONDITION EAA8BC56

Item	Detecting Condition	Possible Cause
DTC Strategy	<ul style="list-style-type: none">Monitors the switch is switching too frequently or stuck for too long.	<ul style="list-style-type: none">Poor connectionFaulty cruise switchFaulty PCM
Enable Conditions	<ul style="list-style-type: none">Engine is runningIgnition voltage 9VCruise control system type is learned	
Threshold Value	<ul style="list-style-type: none">Input switch signal is switching too frequently or stuck	
Diagnosis Time	<ul style="list-style-type: none">Switching: more than 1 second failure for 300 seconds testStuck: more than 75 seconds failure for 300 seconds test	
MIL On Condition	<ul style="list-style-type: none">NO MIL ON(DTC only)	

SPECIFICATION EFB9E506

Refer to DTC P0564.

SCHEMATIC DIAGRAM E4E769E3

Refer to DTC P0564.

MONITOR DTC STATUS E9C22CEF

Refer to DTC P0564.

TERMINAL AND CONNECTOR INSPECTION EEC4D161

Refer to DTC P0565.

CRUISE CONTROL SYSTEM

COMPONENT INSPECTION E5B08D7A

1. Check auto cruise switch.
 - 1) IG "OFF" and disconnect Cruise remocon connector.
 - 2) Measure resistance between terminals 8 and 2 of Cruise remocon connector with "CANCEL" switch depressed.(Component side).

Specification :

Item	Resistance()
CANCEL switch	0 ± 5% between terminals 8 and 2

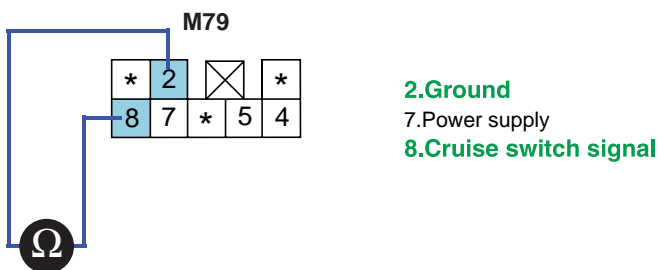

SGHEE7208L

- 3) Is the measured resistance within specification?

YES

Substitute with a known - good PCM and check for proper operation.
If the problem is corrected, replace PCM and go to "Verification of Vehicle Repair" procedure.

NO

Substitute with a known - good auto cruise switch and check for proper operation.
If the problem is corrected, replace auto cruise switch and go to "Verification of Vehicle Repair" procedure.

NOTE

There is a memory reset function on scantool that can erase optional parts automatically detected and memorized by PCM.

After testing PCM on the vehicle, use this function to reuse the PCM on the others.

VERIFICATION OF VEHICLE REPAIR EF96DDB7

Refer to DTC P0564.

DTC P0567 CRUISE CONTROL "RESUME" SIGNAL

COMPONENT LOCATION E98A4F26

Refer to DTC P0564.

GENERAL DESCRIPTION E54910D8

Refer to DTC P0564.

DTC DESCRIPTION EADE9CEF

If the RESUME switch signal is switching too frequently or stuck for too long, PCM sets P0567.

DTC DETECTING CONDITION EE6EBE39

Item	Detecting Condition	Possible Cause
DTC Strategy	<ul style="list-style-type: none">Monitors the switch is switching too frequently or stuck for too long.	<ul style="list-style-type: none">Poor connectionFaulty cruise switchFaulty PCM
Enable Conditions	<ul style="list-style-type: none">Engine is runningIgnition voltage 9VCruise control system type is learned	
Threshold Value	<ul style="list-style-type: none">Input switch signal is switching too frequently or stuck	
Diagnosis Time	<ul style="list-style-type: none">Switching: more than 1 second failure for 300 seconds testStuck: more than 75 seconds failure for 300 seconds test	
MIL On Condition	<ul style="list-style-type: none">NO MIL ON(DTC only)	

SPECIFICATION E4ABB0EE

Refer to DTC P0564.

SCHEMATIC DIAGRAM ECCCCA753

Refer to DTC P0564.

MONITOR DTC STATUS EDA129C2

Refer to DTC P0564.

TERMINAL AND CONNECTOR INSPECTION EE56BC6F

Refer to DTC P0565.

CRUISE CONTROL SYSTEM

COMPONENT INSPECTION

E6C84725

1. Check auto cruise switch.
 - 1) IG "OFF" and disconnect Cruise remocon connector.
 - 2) Measure resistance between terminals 8 and 2 of Cruise remocon connector with "RESUME" switch depressed.(Component side).

Specification :

Item	Resistance()
RESUME switch	910 ± 5% between terminals 8 and 2

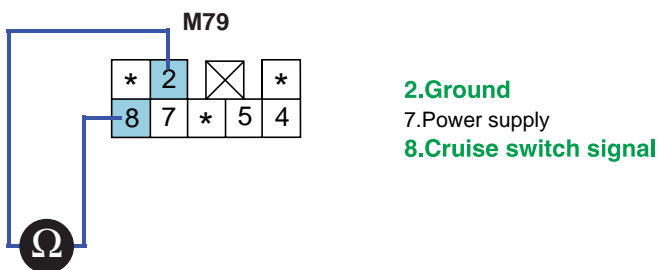

SGHEE7208L

- 3) Is the measured resistance within specification?

YES

Substitute with a known - good PCM and check for proper operation.
If the problem is corrected, replace PCM and go to "Verification of Vehicle Repair" procedure.

NO

Substitute with a known - good auto cruise switch and check for proper operation.
If the problem is corrected, replace auto cruise switch and go to "Verification of Vehicle Repair" procedure.

NOTE

There is a memory reset function on scantool that can erase optional parts automatically detected and memorized by PCM.

After testing PCM on the vehicle, use this function to reuse the PCM on the others.

VERIFICATION OF VEHICLE REPAIR

E7644B92

Refer to DTC P0564.

DTC P0568 CRUISE CONTROL "SET" SIGNAL

COMPONENT LOCATION E6E4BACC

Refer to DTC P0564.

GENERAL DESCRIPTION E9B5D13F

Refer to DTC P0564.

DTC DESCRIPTION E1ED61CF

If the SET switch signal is switching too frequently or stuck for too long, PCM sets P0568.

DTC DETECTING CONDITION ECD12425

Item	Detecting Condition	Possible Cause
DTC Strategy	<ul style="list-style-type: none">Monitors the switch is switching too frequently or stuck for too long.	<ul style="list-style-type: none">Poor connectionFaulty cruise switchFaulty PCM
Enable Conditions	<ul style="list-style-type: none">Engine is runningIgnition voltage 9VCruise control system type is learned	
Threshold Value	<ul style="list-style-type: none">Input switch signal is switching too frequently or stuck	
Diagnosis Time	<ul style="list-style-type: none">Switching: more than 1 second failure for 300 seconds testStuck: more than 75 seconds failure for 300 seconds test	
MIL On Condition	<ul style="list-style-type: none">NO MIL ON(DTC only)	

SPECIFICATION EA1FE46C

Refer to DTC P0564.

SCHEMATIC DIAGRAM E3167C61

Refer to DTC P0564.

MONITOR DTC STATUS EA49939A

Refer to DTC P0564.

TERMINAL AND CONNECTOR INSPECTION E102AF3F

Refer to DTC P0565

CRUISE CONTROL SYSTEM

COMPONENT INSPECTION E1A88FEE

- 1. Check auto cruise switch
 - 1) IG "OFF" and disconnect Cruise remocon connector.
 - 2) Measure resistance between terminals 8 and 2 of Cruise remocon connector with "SET" switch depressed.(Component side)

Specification :

Item	Resistance()
SET switch	220 ± 5% between terminals 8 and 2

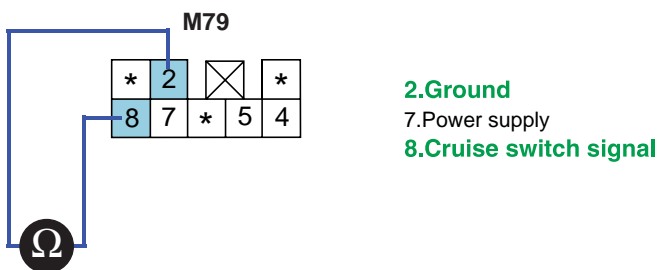

SGHEE7208L

- 3) Is the measured resistance within specification?

YES

Substitute with a known - good PCM and check for proper operation.
If the problem is corrected, replace PCM and go to "Verification of Vehicle Repair" procedure.

NO

Substitute with a known - good auto cruise switch and check for proper operation.
If the problem is corrected, replace auto cruise switch and go to "Verification of Vehicle Repair" procedure.

NOTE

There is a memory reset function on scantool that can erase optional parts automatically detected and memorized by PCM.

After testing PCM on the vehicle, use this function to reuse the PCM on the others

VERIFICATION OF VEHICLE REPAIR E51C8DA0

Refer to DTC P0564.

CRUISE CONTROL MAIN SWITCH

CIRCUIT DIAGRAM EF4DDF0C

*	2	⊗	*
8	7	*	5 4

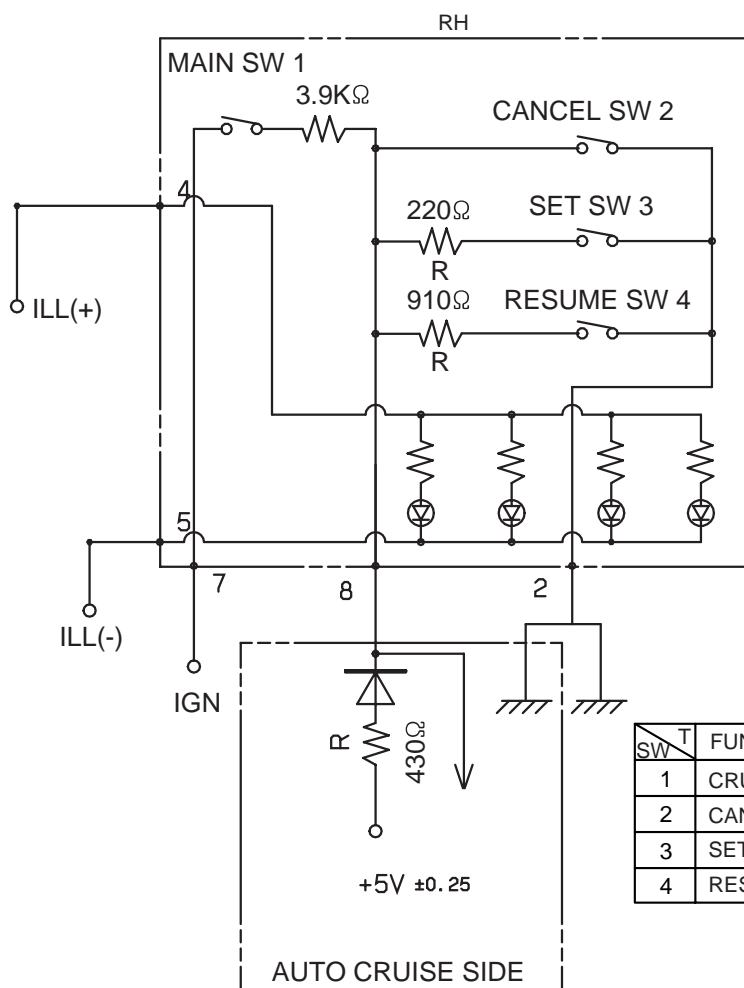
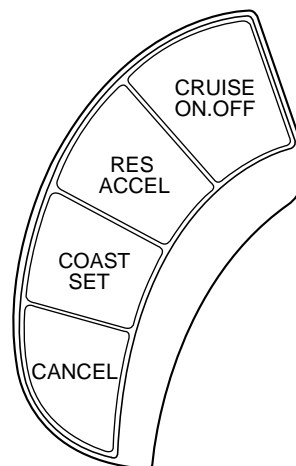

SW	T	FUNCTION	OHM	OUT PUT VOLTAGE
1		CRUISE MAIN	3.9kΩ±1%	-
2		CANCEL	0 Ω±1%	0V ±0.22V
3		SET/COAST	220 Ω ±1%	1.5V ±0.22V
4		RESUME/ACCEL	910 Ω ±1%	3.0V ±0.22V

CRUISE CONTROL SYSTEM

REMOVAL EB14E8F7

1. Disconnect the battery (-) terminal.
2. Remove the driver side air bag module.
3. Disconnect the cruise control switch connector and then remove the cruise control switch with two screws.
4. Installation is the reverse of removal.

INSPECTION EE6C0D38

MEASURING RESISTANCE

1. Disconnect the cruise control switch connector from the control switch.

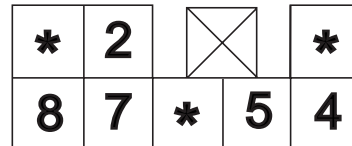

SGHEE7007N

2. Measure resistance between terminals on the control switch when each function switch is ON (switch is depressed).

Function switch	Terminal	Resistance
Cruise Main	7-8	3.9k ± 1%
Cancel	8-2	0 ± 1%
Set/Coast	8-2	220 ± 1%
Resume/Accel	8-2	910 ± 1%

3. If not within specification, replace switch.

MEASURING VOLTAGE

1. Connect the cruise control switch connector to the control switch.

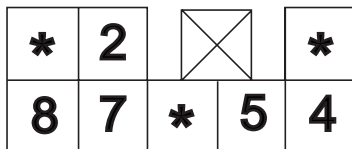

SGHEE7007N

2. Measure voltage between terminals on the harness side connector when each function switch is ON (switch is depressed).

Function switch	Terminal	Voltage
Cruise Main	7-8	-
Cancel	8-2	0.0V ± 0.22V
Set/Coast	8-2	1.5V ± 0.22V
Resume/Accel	8-2	3.0V ± 0.22V

3. If not within specification, replace switch.