

Emissions Control System

GENERAL

CRANKCASE EMISSION CONTROL SYSTEM

POSITIVE CRANKCASE VENTILATION (PCV) VALVE

EVAPORATIVE EMISSION CONTROL SYSTEM

EVAPORATIVE (EVAP) CANISTER
CANISTER AIR FILTER
EVAPORATIVE (EVAP) CANISTER PURGE SOLENOID VALVE
FUEL FILLER CAP
OVERFILL LIMITER (TWO WAY VALVE)

EXHAUST EMISSION CONTROL SYSTEM

GENERAL

SPECIFICATIONS EA4C2583

Item	Specification	
	Type	Duty Control type
Purge Control Solenoid Valve (PCSV)	Resistance ()	19 ~ 22 at 20 °C (68 °F)

TIGHTENING TORQUE

Item	N-m	kg-cm	lb-ft
Positive Crankcase Ventilation Valve	8 ~ 12	80 ~ 120	6 ~ 8

TROUBLESHOOTING

Symptom	Suspect area	Remedy
Engine will not start or hard to start	Vacuum hose disconnected or damaged	Repair or replace
	Malfunction of the EVAP. Canister Purge Solenoid Valve	Repair or replace
Rough idle or engine stalls	Vacuum hose disconnected or damaged	Repair or replace
	Malfunction of the PCV valve	Replace
	Malfunction of the evaporative emission canister purge system	Check the system; if there is a problem, check related components parts
Excessive oil consumption	Positive crankcase ventilation line clogged	Check positive crankcase ventilation system

COMPONENTS

Components	Function	Remarks
Crankcase Emission System Positive Crankcase Ventilation (PCV) valve	HC reduction	Variable flow rate type
Evaporative Emission System Evaporative emission canister Purge Control Solenoid Valve (PCSV)	HC reduction HC reduction	Duty control solenoid valve
Exhaust Emission System MFI system (air-fuel mixture control device) Three-way catalytic converter	CO, HC, NOx reduction CO, HC, NOx reduction	Heated oxygen sensor feedback type Monolithic type

MFI : Multiport Fuel Injection
EVAP : Evaporative Emission

COMPONENTS LOCATION E5A329D7

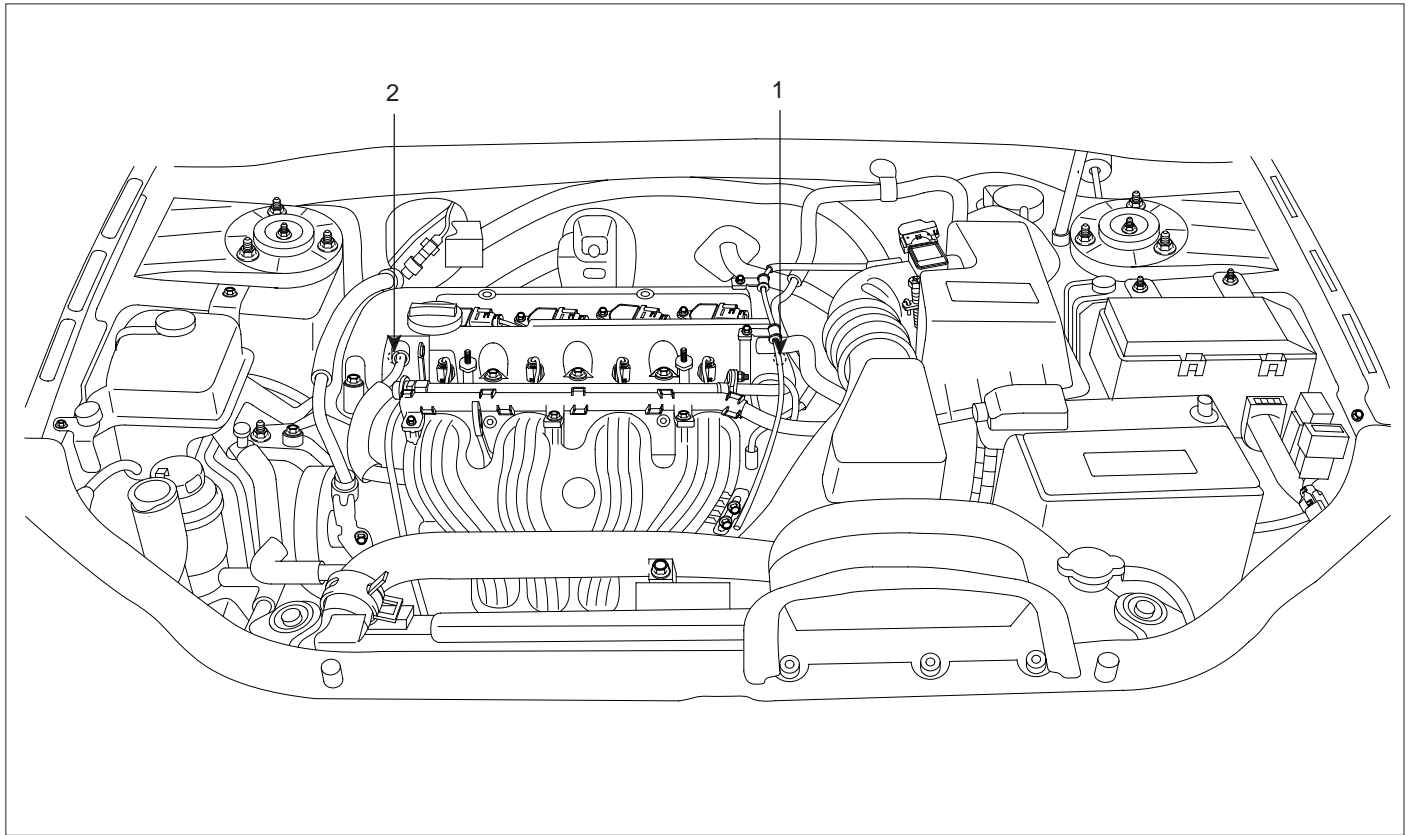

- | | |
|--|------------------------|
| 1. Purge Control Solenoid Valve (PCSV) | 3. Canister |
| 2. PCV Valve | 4. Catalytic Converter |
| 5. Two Way Valve & Cut Valve | 6. Canister Filter |

EERF301A

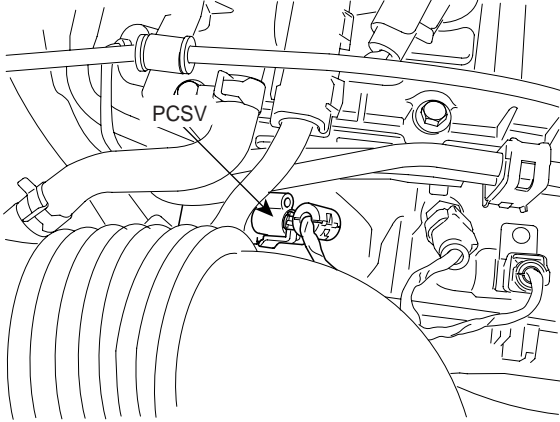
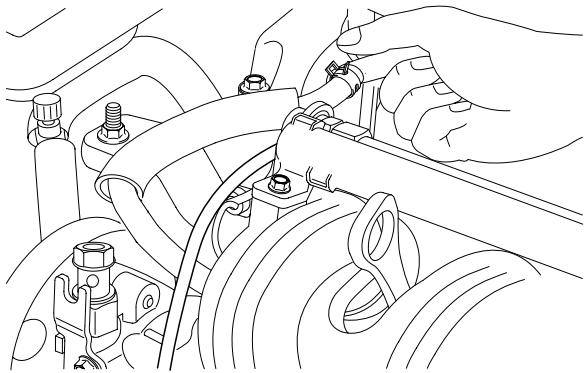
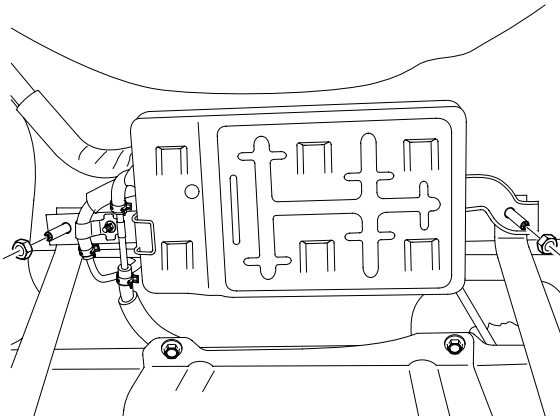
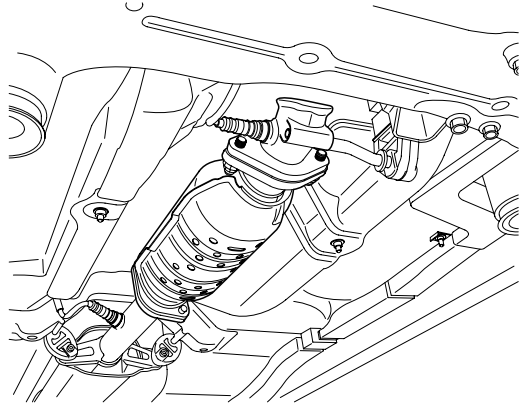
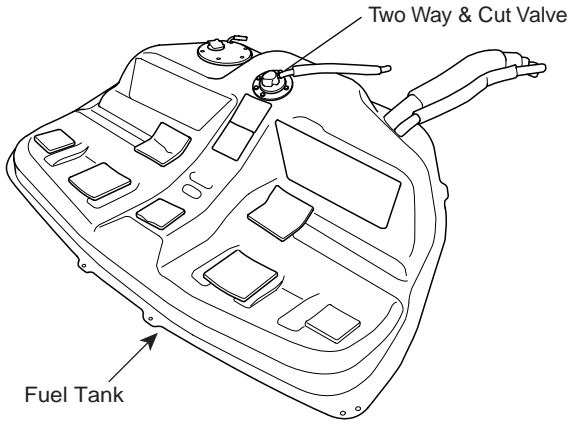
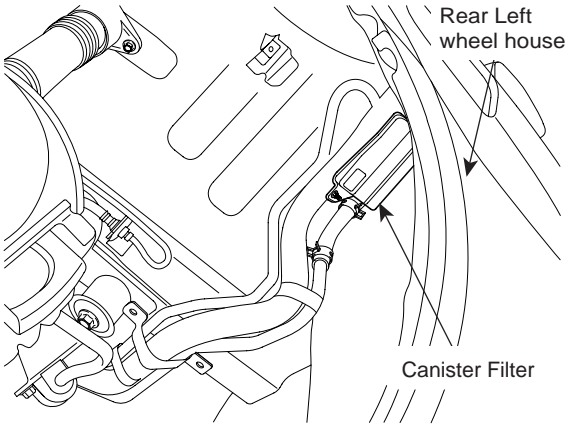
1 Purege Control Solenoid Valve (PCSV)	2 Positive Crankcase Ventilation (PCV) Valve
 <p>KERE020A</p>	 <p>KERE083A</p>
3 Canister	4 Catalytic Converter
 <p>KERE040B</p>	 <p>KERE087A</p>
5 Two way & Cut Valve	6 Canister Filter
 <p>Two Way & Cut Valve</p> <p>Fuel Tank</p> <p>ERFE026A</p>	 <p>Rear Left wheel house</p> <p>Canister Filter</p> <p>EERF041B</p>

SCHEMATIC DIAGRAM E7FF19CF

- *1. Mass Air Flow Sensor (MAFS)
- *2. Engine Coolant Temperature Sensor (ECTS)
- *3. Crankshaft Position Sensor (CKPS)
- *4. Camshaft Position Sensor (CMPS)
- *5. Heated Oxygen Sensor (HO2S) - Front
- *6. Heated Oxygen Sensor (HO2S) - Rear
- *7. Knock Sensor
- *8. Vehicle Speed Sensor
- *9. Intake Air Temperature Sensor
- *10. CVVT Oil Temperature Sensor (OTS)
- *11. Accelerator Position Sensor (APS)
- *12. Power Steering Pressure Sensor

- **1. Injector
- **2. Ignition Coil
- **3. Purge Control Solenoid Valve (PCSV)
- **4. Main Relay
- **5. Fuel Pump Relay
- **6. CVVT Oil Control Valve (OCV)
- **7. ETS Motor

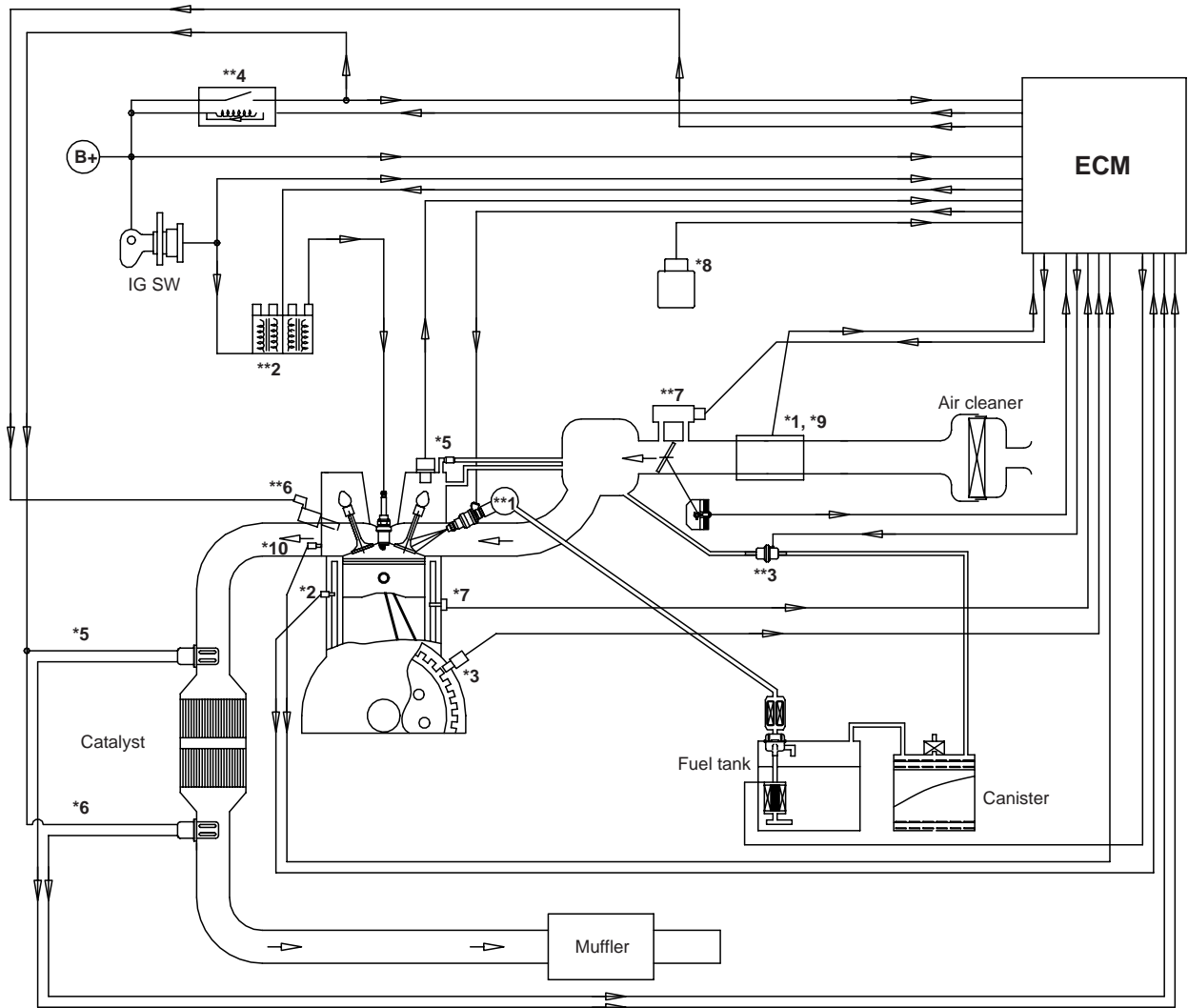

CRANKCASE EMISSION CONTROL SYSTEM

COMPONENTS LOCATION ED593335

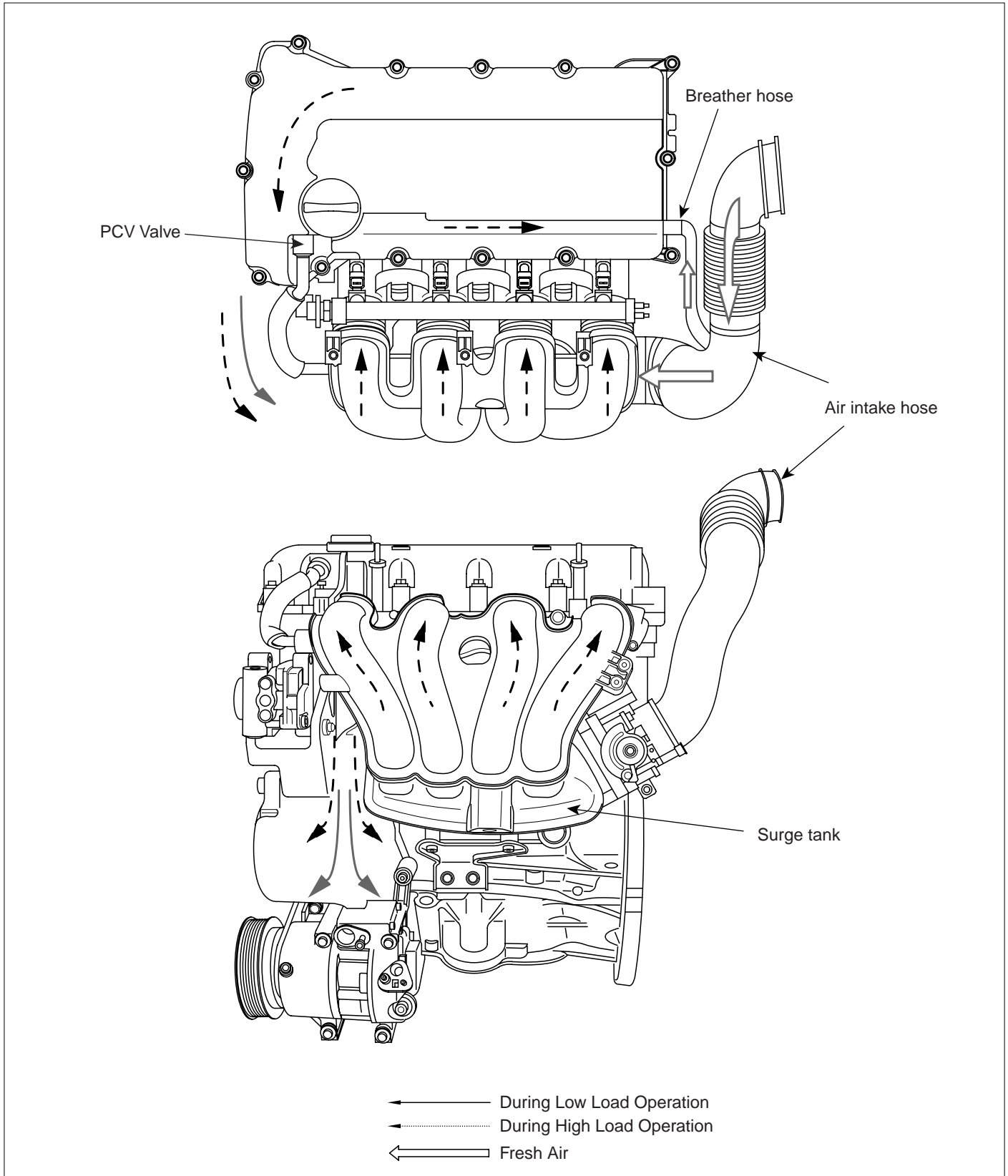

POSITIVE CRANKCASE VENTILATION (PCV) VALVE

OPERATION E7AEA1F5

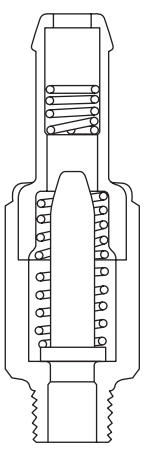
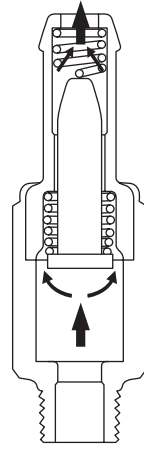
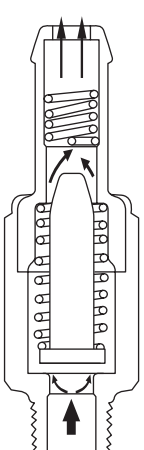
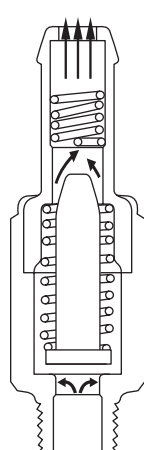
<p>Intake manifold side (No vacuum)</p>  <p>Rocker cover side</p> <p style="text-align: right;">BEGE001S</p>		<p>Intake manifold side (High vacuum)</p>  <p>Rocker cover side</p> <p style="text-align: right;">BEGE001T</p>	
Engine condition	Not running	Engine condition	Idling or decelerating
PCV valve	Not operating	PCV valve	Fully operating
Vacuum passage	Restricted	Vacuum passage	Small
<p>Intake manifold side (Moderate vacuum)</p>  <p>Rocker cover side</p> <p style="text-align: right;">BEGE001U</p>		<p>Intake manifold side (Low vacuum)</p>  <p>Rocker cover side</p> <p style="text-align: right;">BEGE001V</p>	
Engine condition	Normal operation	Engine condition	Accelerating and high load
PCV valve	Properly operating	PCV valve	Slightly operating
Vacuum passage	Large	Vacuum passage	Very large

REMOVAL EEC0EB80

1. Disconnect the ventilation hose from the positive crankcase ventilation (PCV) valve. Remove the PCV valve from the rocker cover and reconnect it to the ventilation hose.
2. Run the engine at idle and put a finger on the open end of the PCV valve and make sure that intake manifold vacuum can be felt.

 **NOTE**

The plunger inside the PCV valve will move back and forth.

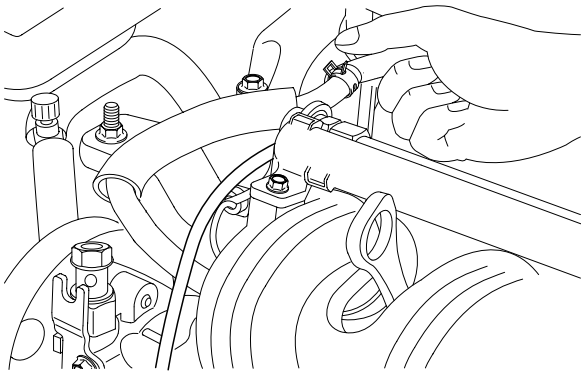

KERE083A

INSPECTION E28F9F53

1. Remove the PCV valve.
2. Insert a thin stick(A) into the PCV valve(B) from the threaded side to check that the plunger moves.
3. If the plunger does not move, the PCV valve is clogged. Clean it or replace.

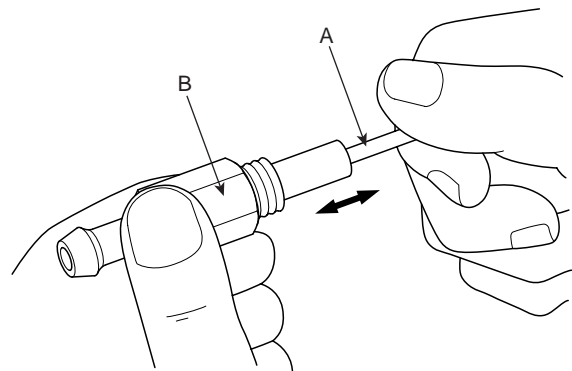

EGQE603J

INSTALLATION E20AEB46

Install the PCV valve and tighten to the specified torque.

PCV valve : 0.8~1.2 kgf·m

EVAPORATIVE EMISSION CONTROL SYSTEM

COMPONENTS E988A4E0

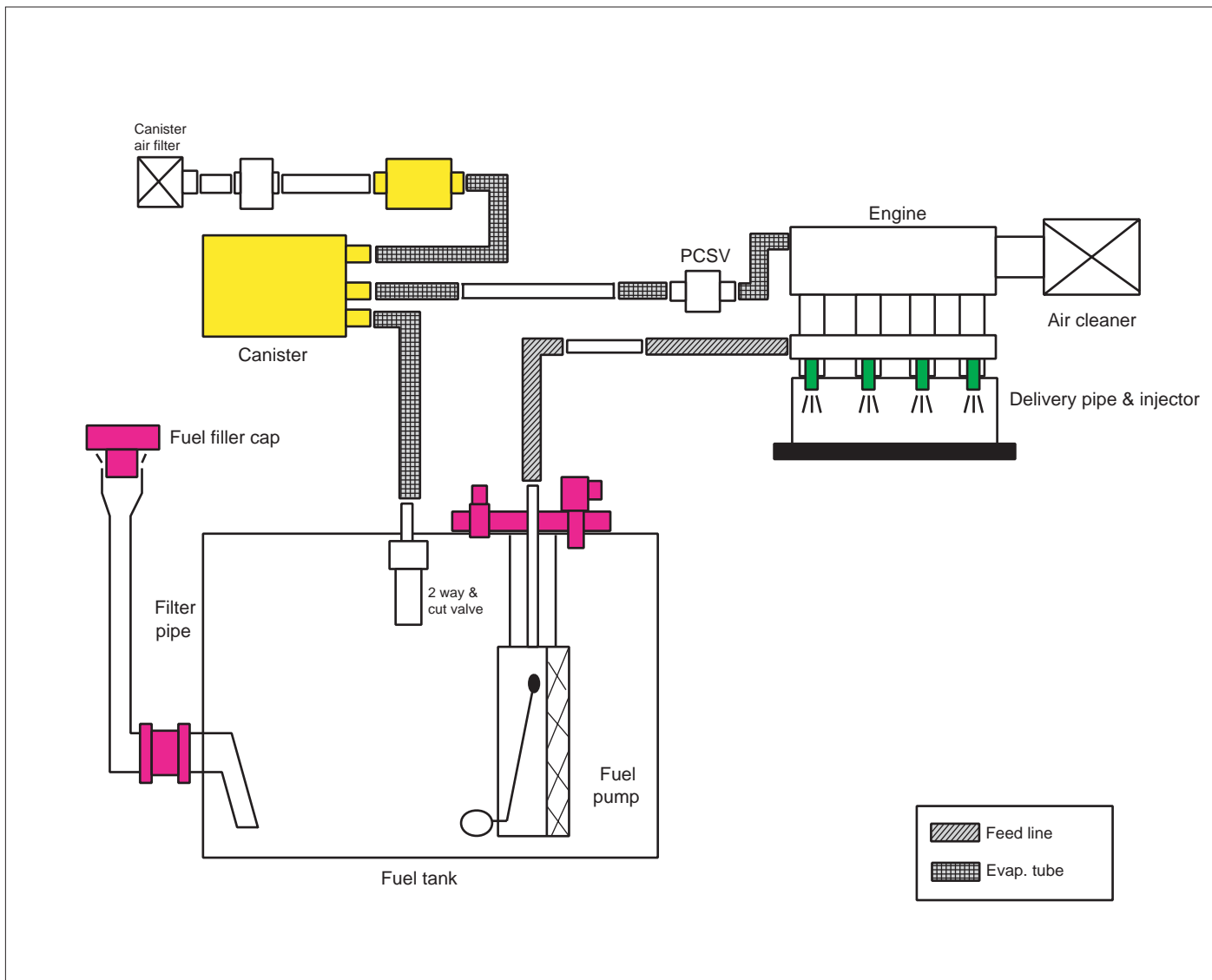

EERF0011

CANISTER

Canister accumulates vapor from fuel tank. ECM controls PCSV to send vapor to intake manifold.

PURGE CONTROL SOLENOID VALVE (PCSV)

PCSV is installed between intake manifold and canister. ECM controls PCSV, which is operated by vacuum, to send vapor in canister to intake manifold.

INSPECTION ECBCB4B8

1. Disconnect the vacuum hose from the throttle body, and connect a vacuum pump to the vacuum hose.
2. Check the following points when the engine is cold [engine coolant temperature 60°C(140°F) or below] and when it is warm [engine coolant temperature 80°C(176°F) or higher].

WHEN ENGINE IS COLD

Engine operating condition	Applied vacuum	Result
Idling	50 kPa (7.3 psi)	Vacuum is held
3,000 rpm		

WHEN ENGINE IS WARM

Engine operating condition	Applied vacuum	Result
Idling	50 kPa (7.3 psi)	Vacuum is held
Within 3 minutes after engine start at 3,000 rpm	Try to apply vacuum	Vacuum is released
After 3 minutes have passed after engine start at 3,000 rpm	50 kPa (7.3 psi)	Vacuum will be held momentarily, after which, it will be released

EVAPORATIVE (EVAP) CANISTER

INSTALLATION E6ECCF12

REMOVAL EA9C2B0C

1. Disconnect hoses (A), (B) connecting to the canister(D).
2. Unfasten two mounting bolts(C) and remove the canister(D).

Installation is in reverse order of removal.

Torque : 4.0 ~ 5.5kgf·m

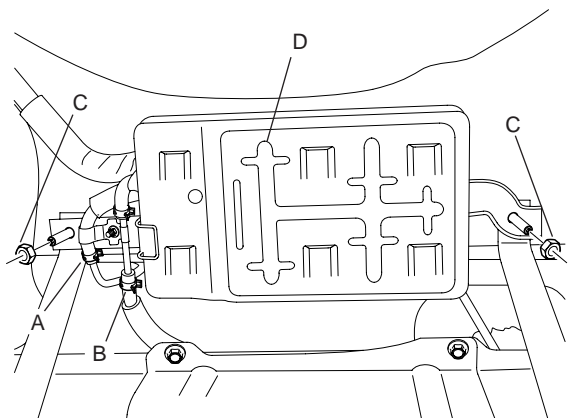

EERF040A

INSPECTION EAFCEFAC

1. Look for loose connections, sharp bends or damage to the fuel vapor lines.
2. Look for distortion, cracks or fuel damage.
3. After removing the canister, inspect for cracks or damage.

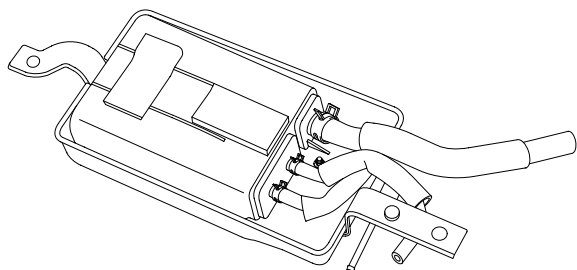

KERE039A

CANISTER AIR FILTER

REPLACE E4F42BA3

1. Remove the rear left wheel house.
(Refer to "BD" group)
2. Unfasten three mounting nuts.

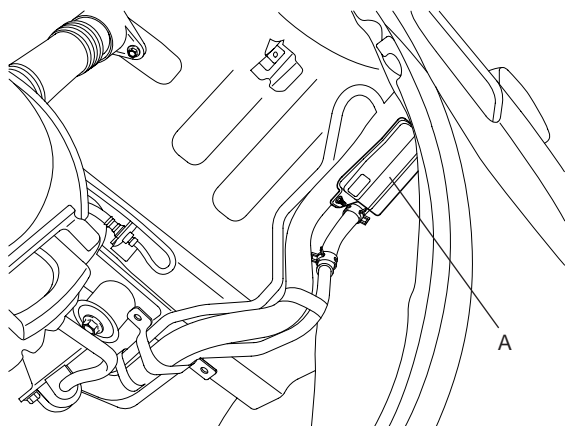

KERE041A

3. Remove the canister air filter(A).
4. Install a new canister air filter.

EVAPORATIVE (EVAP) CANISTER PURGE SOLENOID VALVE

- 5. Measure the resistance between the terminals of the solenoid valve.

INSPECTION E69C9BA7

NOTE

When disconnecting the vacuum hose, make an identification mark on it so that it can be reconnected to its original position.

- 1. Disconnect the vacuum hose from the solenoid valve.
- 2. Detach the harness connector.
- 3. Connect a vacuum pump to the nipple to which the red-striped vacuum hose was connected.
- 4. Apply vacuum and check when voltage is applied to the PCSV and when the voltage is discontinued.

Battery voltage	Normal condition
When applied	Vacuum is released
When discontinued	Vacuum is maintained

PCSV coil resistance () :
19 ~ 22 at 20 (68)

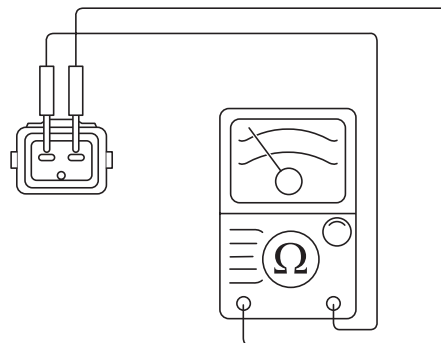

KERE001M

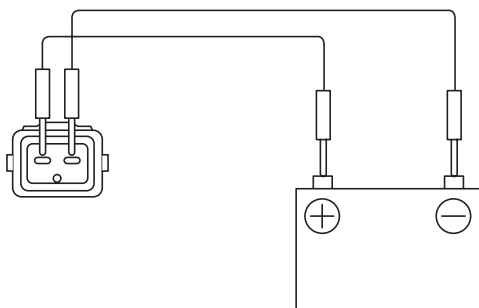

KERE001L

FUEL FILLER CAP

DESCRIPTION E6E243DC

A ratchet tightening device on the threaded fuel filler cap reduces the chances of incorrect installation, which would

seal the fuel filler. After the gasket on the fuel filler cap and the filler neck flange contact each other, the ratchet produces a loud clicking noise indicating the seal has been set.

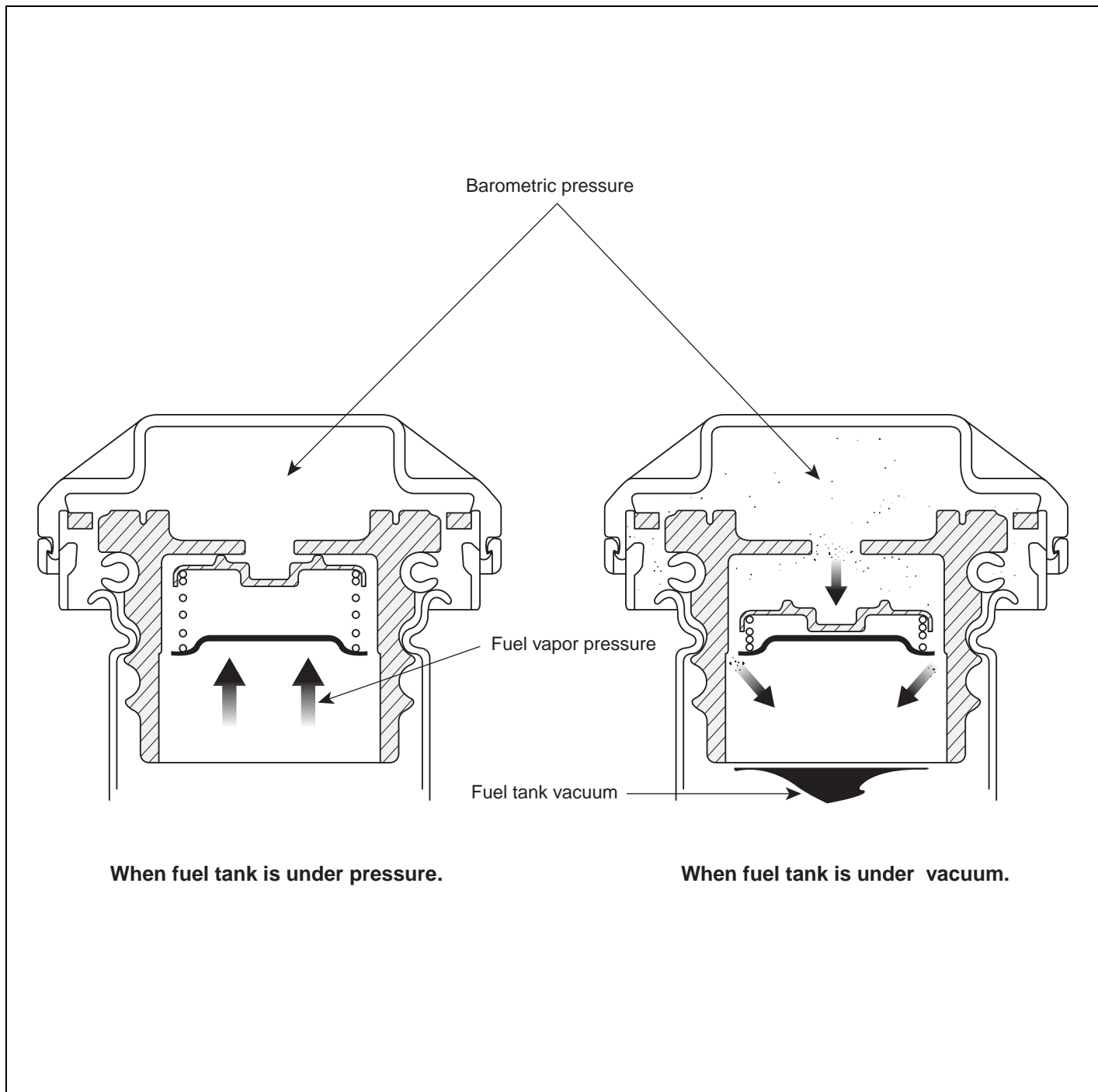

LEGE015A

OVERFILL LIMITER (TWO WAY VALVE)

CHARACTERISTICS OPERATION () - VACUUM VALVE

DESCRIPTION EDB003C4

Two-way valve consists of a pressure valve and a vacuum valve. The pressure valve opens when the internal pressure of fuel tank gets higher than specification and the vacuum valve opens when the fuel tank forms a vacuum.

Pressure (kPa)	Flow
-0.981 kPa	above 5 /min

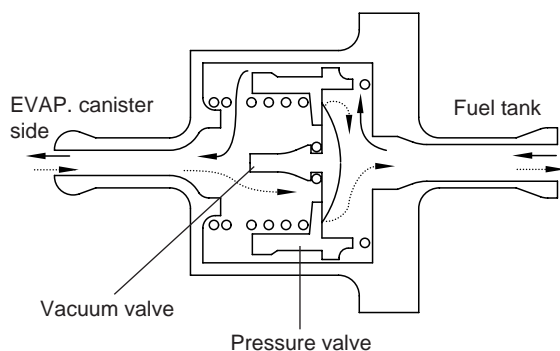

EERF014A

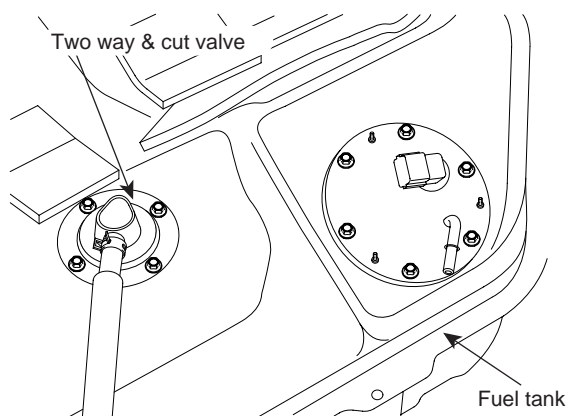

EERF080A

CHARACTERISTICS OPERATION () - PRESSURE VALVE

Pressure (kPa)	Flow
3.432 kPa	below 3 /min
4.903 kPa	above 10 /min
5.884 kPa	above 15 /min
9.806 kPa	above 25 /min

EXHAUST EMISSION CONTROL SYSTEM

DESCRIPTION E933DCFA

Exhaust emissions (CO, HC, NOx) are controlled by a combination of engine modifications and the addition of special control components.

Modifications to the combustion chamber, intake manifold, camshaft and ignition system form the basic control system.

These items have been integrated into a highly effective system which controls exhaust emissions while maintaining good driveability and fuel economy.

AIR/FUEL MIXTURE CONTROL SYSTEM [MULTIPOINT FUEL INJECTION (MFI) SYSTEM]

The MFI system is a system which uses the signals from the heated oxygen sensor to activate and control the injector installed in the manifold for each cylinder, thus precisely regulating the air/fuel mixture ratio and reducing emissions.

This in turn allows the engine to produce exhaust gases of the proper composition to permit the use of a three way catalyst. The three way catalyst is designed to convert the three pollutants (1) hydrocarbons (HC), (2) carbon monoxide (CO), and (3) oxides of nitrogen (NOx) into harmless substances. There are two operating modes in the MFI system.

1. Open Loop air/fuel ratio is controlled by information programmed into the ECM.
2. Closed Loop air/fuel ratio is adjusted by the ECM based on information supplied by the oxygen sensor.