

Emissions Control System

GENERAL

CRANKCASE EMISSION CONTROL SYSTEM

POSITIVE CRANKCASE VENTILATION (PCV) VALVE

EVAPORATIVE EMISSION CONTROL SYSTEM

EVAPORATIVE (EVAP) CANISTER
EVAPORATIVE (EVAP) CANISTER PURGE SOLENOID VALVE
FUEL FILLER CAP
FUEL TANK AIR FILTER

EXHAUST EMISSION CONTROL SYSTEM

CONTINUOUS VARIABLE VALVE TIMING (CVVT)

GENERAL

SPECIFICATIONS E7BA2500

Item	Specification	
	Type	Duty Control type
Purge Control Solenoid Valve (PCSV)	Resistance (Ω)	19.0 ~ 22.0 at 20 °C (68 °F)

TIGHTENING TORQUE E485B3C4

Item	N-m	kgf-m	lbf-ft
Positive Crankcase Ventilation(PCV) Valve	7.8 ~ 11.8	0.8 ~ 1.2	5.8 ~ 8.7

TROUBLESHOOTING E337ABF4

Symptom	Suspect area	Remedy
Engine will not start or hard to start	Vacuum hose disconnected or damaged	Repair or replace
	Malfunction of the EVAP. Canister Purge Solenoid Valve	Repair or replace
Rough idle or engine stalls	Vacuum hose disconnected or damaged	Repair or replace
	Malfunction of the PCV valve	Replace
	Malfunction of the evaporative emission canister purge system	Check the system; if there is a problem, check related components parts
Excessive oil consumption	Positive crankcase ventilation line clogged	Check positive crankcase ventilation system

DESCRIPTION E9461B4E

Components	Function	Remarks
Crankcase Emission System Positive Crankcase Ventilation (PCV) valve	HC reduction	Variable flow rate type
Evaporative Emission System Evaporative emission canister Purge Control Solenoid Valve (PCSV)	HC reduction HC reduction	Duty control solenoid valve
Exhaust Emission System MFI system (air-fuel mixture control device) Three-way catalytic converter	CO, HC, NOx reduction CO, HC, NOx reduction	Heated oxygen sensor feedback type Monolithic type

MFI : Multiport Fuel Injection
EVAP : Evaporative Emission

COMPONENTS LOCATION E006B281

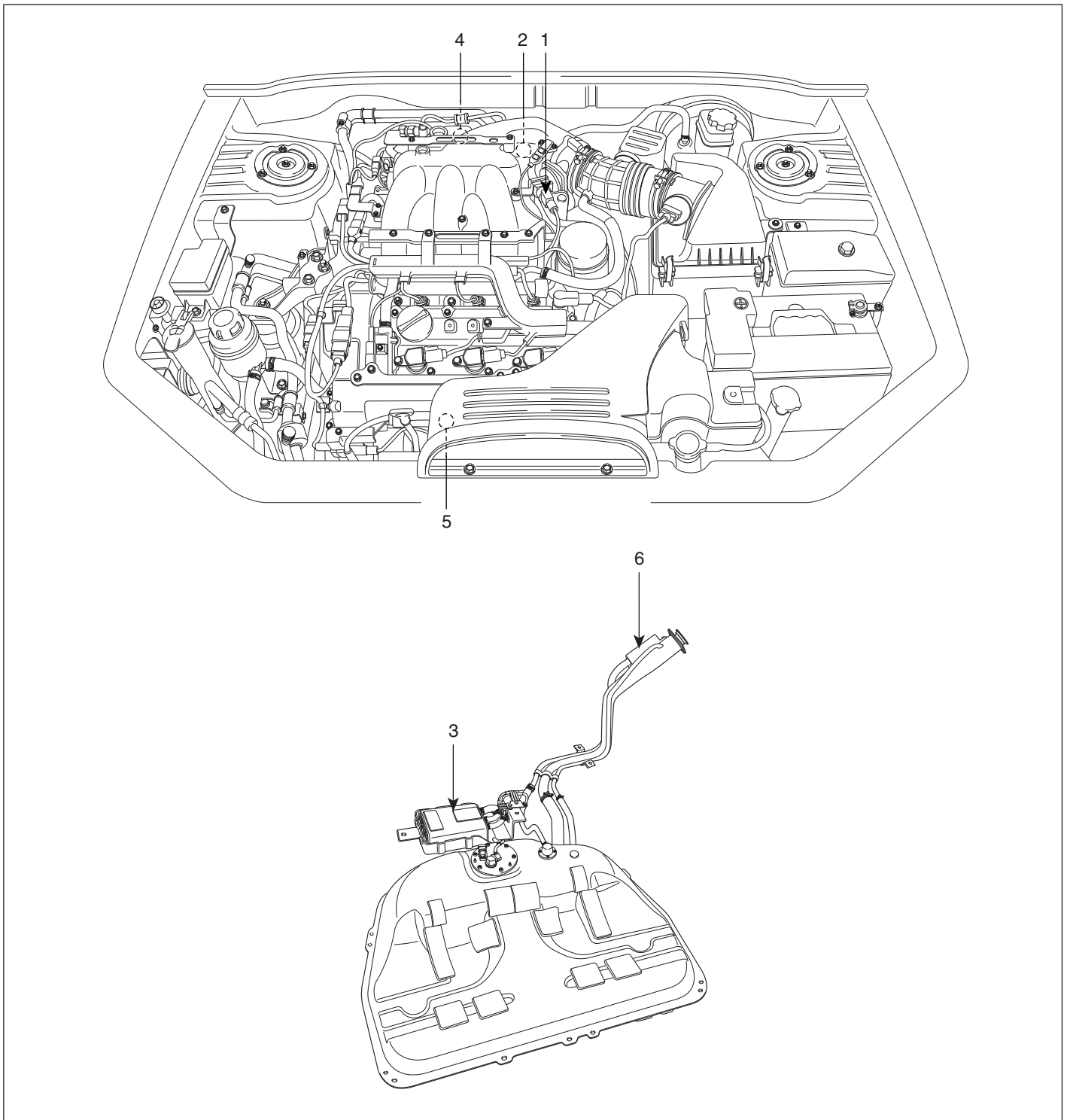

- 1. Purge Control Solenoid Valve (PCSV)
- 2. PCV Valve
- 3. Canister
- 4. Catalytic Converter (Bank 1)
- 5. Catalytic Converter (Bank 2)
- 6. Fuel Tank Air Filter

SGHEC7100L

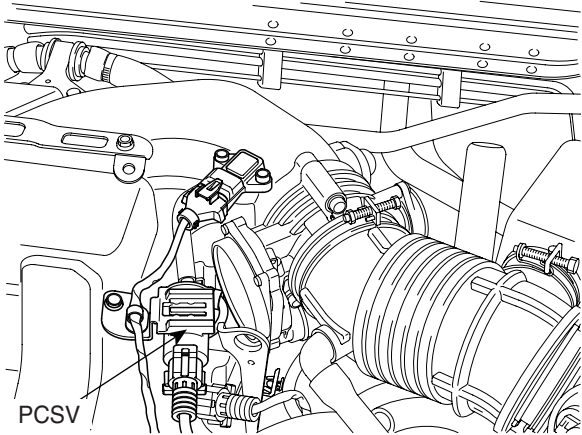
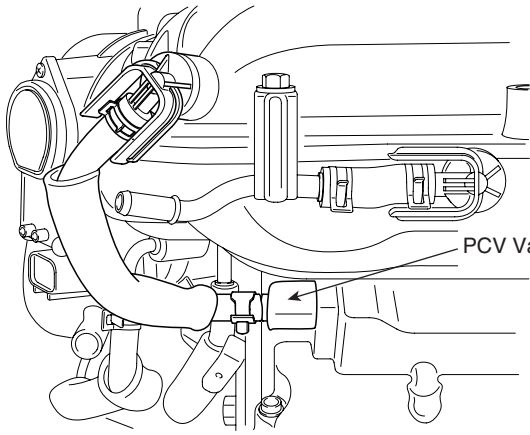
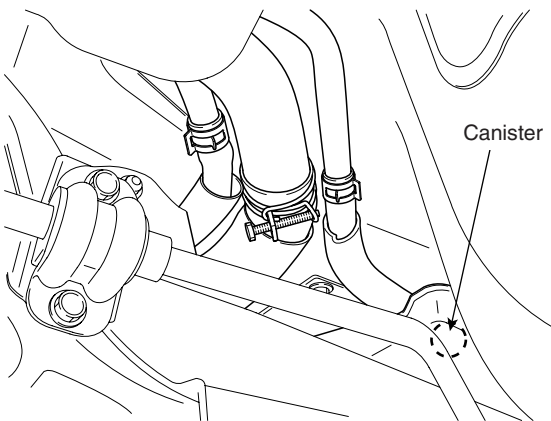
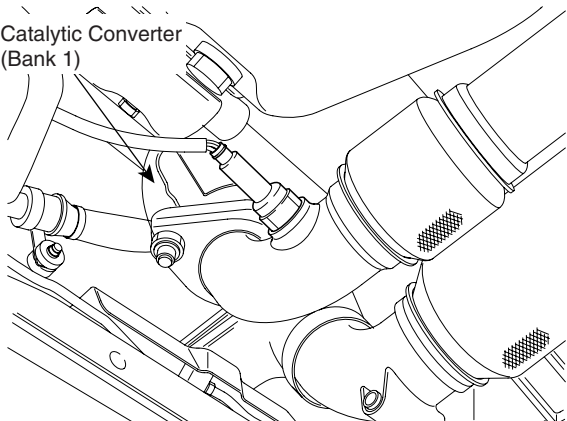
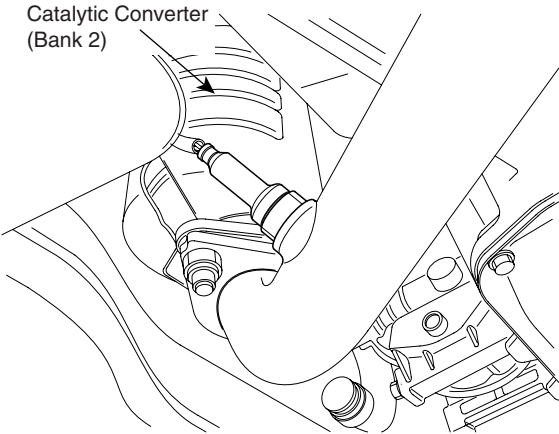
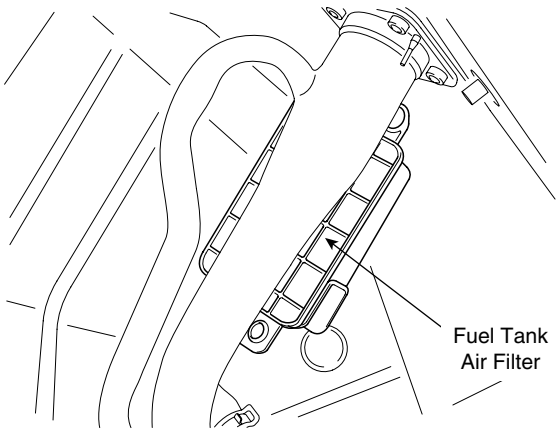
1 Purge Control Solenoid Valve (PCSV)	2 Positive Crankcase Ventilation (PCV) Valve
 <p>PCSV</p> <p>SGHEC7101L</p>	 <p>PCV Valve</p> <p>EEBF001B</p>
3 Canister	4 Catalytic Converter (Bank 1)
 <p>Canister</p> <p>EEBF001C</p>	 <p>Catalytic Converter (Bank 1)</p> <p>EEBF001D</p>
5 Catalytic Converter (Bank 2)	6 Fuel Tank Air Filter
 <p>Catalytic Converter (Bank 2)</p> <p>EEBF001E</p>	 <p>Fuel Tank Air Filter</p> <p>EEBF001F</p>

SCHEMATIC DIAGRAM

EA53DC96

- *1. Mass Air Flow Sensor (MAFS)
- *2. Intake Air Temperature Sensor (IATS)
- *3. Engine Coolant Temperature Sensor (ECTS)
- *4. Throttle Position Sensor (TPS)
- *5-1. Camshaft Position Sensor (CMPS) [BANK1]
- *5-2. Camshaft Position Sensor (CMPS) [BANK2]
- *6. Crankshaft Position Sensor (CKPS)
- *7-1. Knock Sensor (KS) #1
- *7-2. Knock Sensor (KS) #2
- *8-1. Heated Oxygen Sensor (HO2S) [B1/S1]
- *8-2. Heated Oxygen Sensor (HO2S) [B1/S2]
- *9-1. Heated Oxygen Sensor (HO2S) [B2/S1]
- *9-2. Heated Oxygen Sensor (HO2S) [B2/S2]
- *10. Manifold Absolute Pressure Sensor (MAPS)
- *11. CVVT Oil Temperature Sensor (OTS)

- Ignition Switch
- Battery Voltage
- Vehicle Speed Signal
- Coolant Load Signal
- "PNP" Switch (A/T only)
- Fuel Pump Relay Signal



- **1. Fuel Injector
- **2. Ignition Coil
- **3. Purge Control Solenoid Valve (PCSV)
- **4-1. CVVT Oil control valve (OCV) [BANK1]
- **4-2. CVVT Oil control valve (OCV) [BANK2]
- **5. Variable Intake Manifold solenoid (VIS) Valve
- **6. ETC Motor
- Fuel Pump Control
- Main Relay
- Cooler Relay
- Ignition Timing Control
- Diagnosis

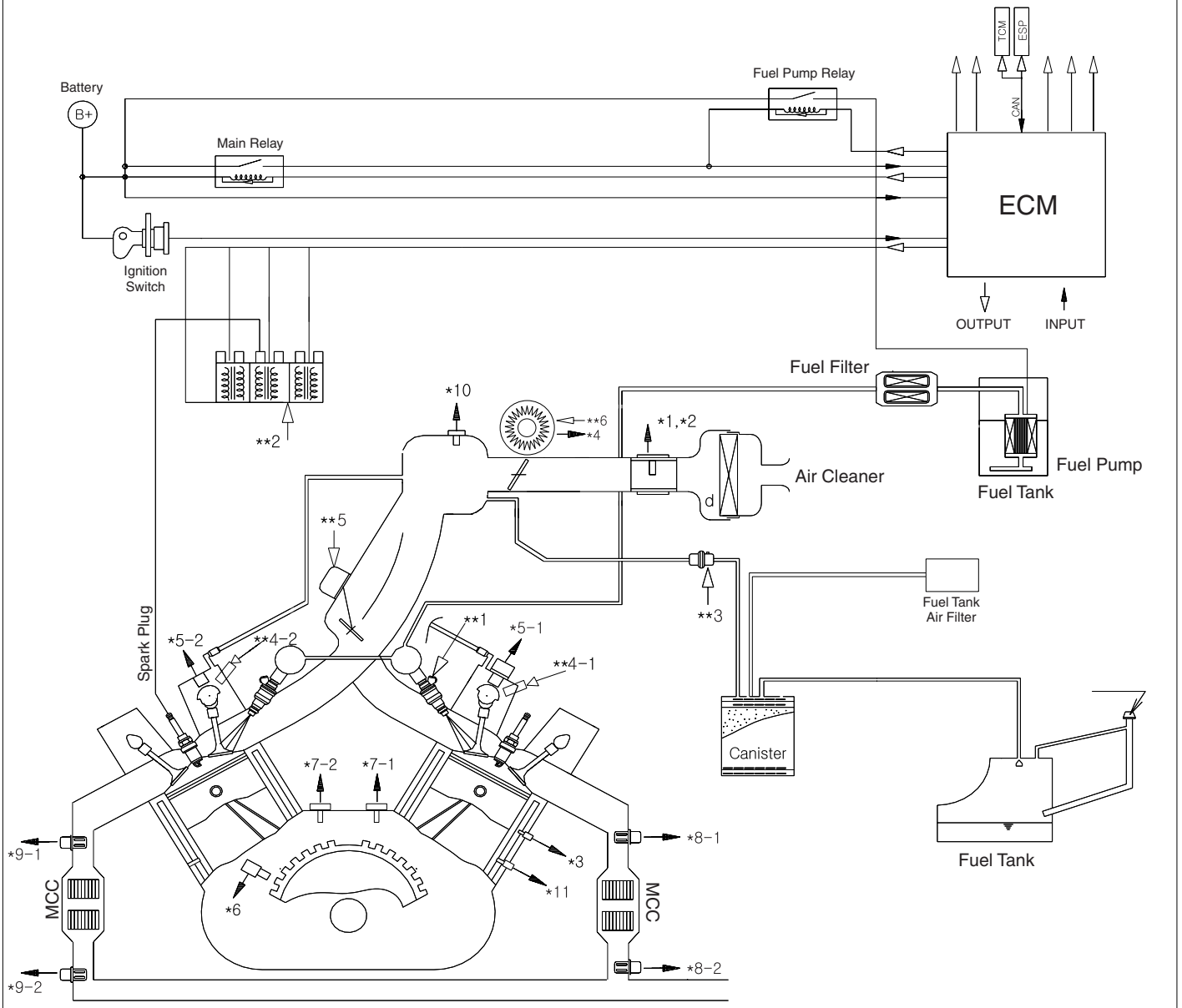

EERF600G

CRANKCASE EMISSION CONTROL SYSTEM

COMPONENT LOCATION E6A0E5F2

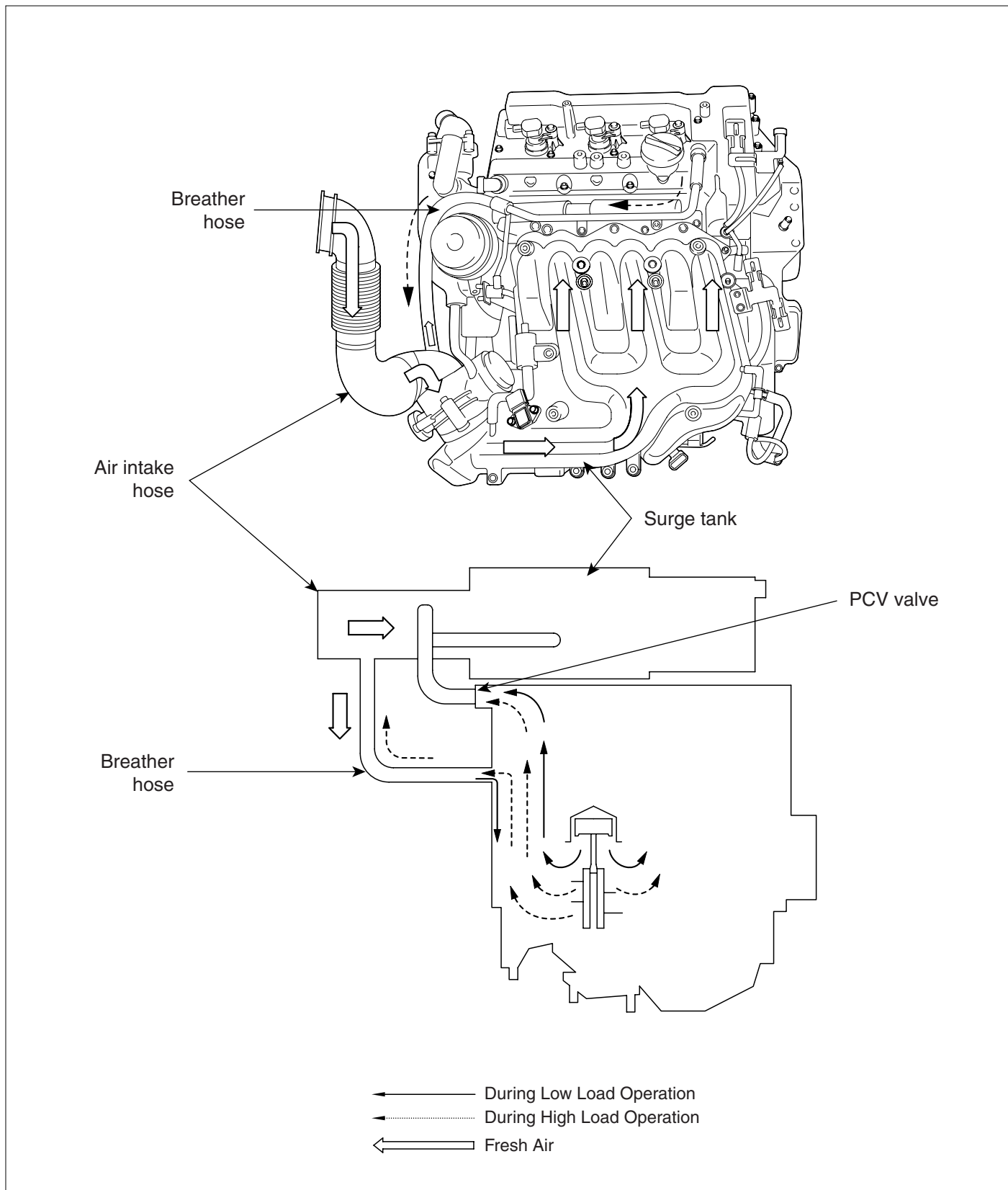

INSPECTION EF68A627

1. Disconnect the ventilation hose from the positive crankcase ventilation (PCV) valve. Remove the PCV valve from the rocker cover and reconnect it to the ventilation hose.
2. Run the engine at idle and put a finger on the open end of the PCV valve and make sure that intake manifold vacuum can be felt.

 **NOTE**

The plunger inside the PCV valve will move back and forth.

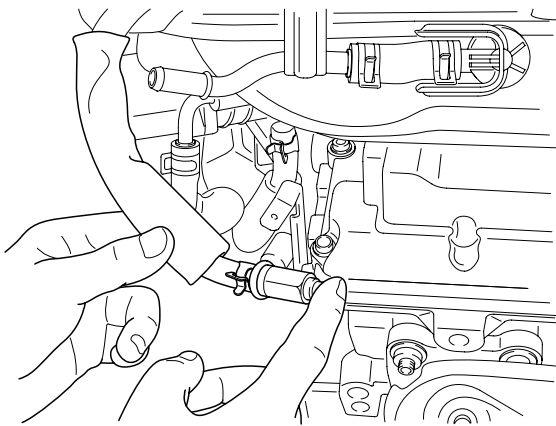

EERF600H

POSITIVE CRANKCASE VENTILATION (PCV) VALVE

OPERATION ECD12BBE

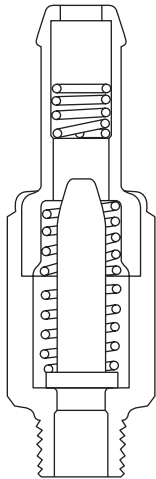
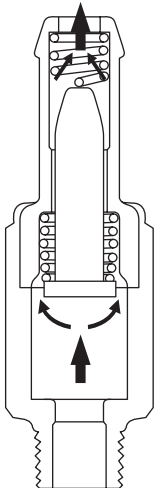
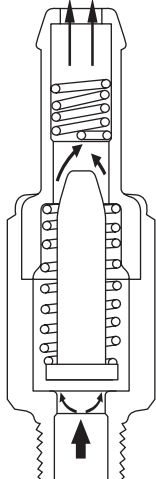
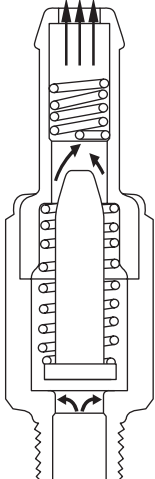
<p>Intake manifold side (No vacuum)</p>  <p>Rocker cover side</p>		<p>Intake manifold side (High vacuum)</p>  <p>Rocker cover side</p>	
Engine condition	Not running	Engine condition	Idling or decelerating
PCV valve	Not operating	PCV valve	Fully operating
Vacuum passage	Restricted	Vacuum passage	Small
<p>Intake manifold side (Moderate vacuum)</p>  <p>Rocker cover side</p>		<p>Intake manifold side (Low vacuum)</p>  <p>Rocker cover side</p>	
Engine condition	Normal operation	Engine condition	Accelerating and high load
PCV valve	Properly operating	PCV valve	Slightly operating
Vacuum passage	Large	Vacuum passage	Very large

CRANKCASE EMISSION CONTROL SYSTEM

EC -9

REMOVAL ECB3E278

1. Remove the valve pad (A) and disconnect the vacuum hose (B).

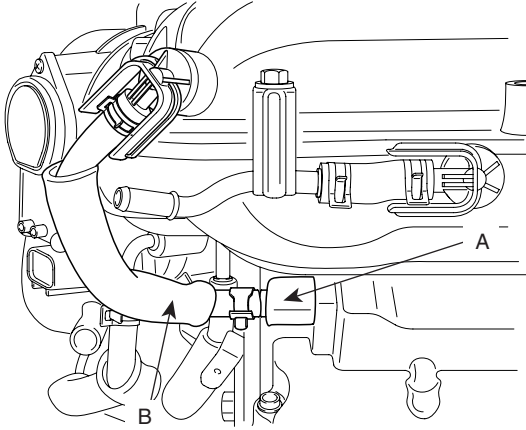

EERF600I

2. Remove the PCV Valve.

INSPECTION E22AB279

1. Remove the PCV valve.
2. Insert a thin stick (A) into the PCV valve (B) from the threaded side to check that the plunger moves.
3. If the plunger does not move, the PCV valve is clogged. Clean it or replace.

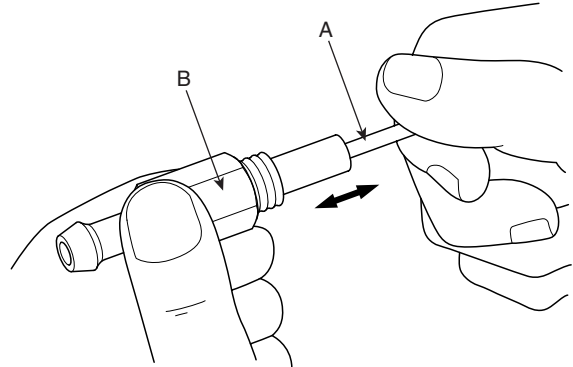

EERF600J

INSTALLATION E66CAEC1

Install the PCV valve and tighten to the specified torque.

PCV Valve installation : 7.8 ~ 11.8 N·m (0.8 ~ 1.2 kgf·m, 5.8 ~ 8.7 lbf·ft)

EVAPORATIVE EMISSION CONTROL SYSTEM

DESCRIPTION E6E4F54B

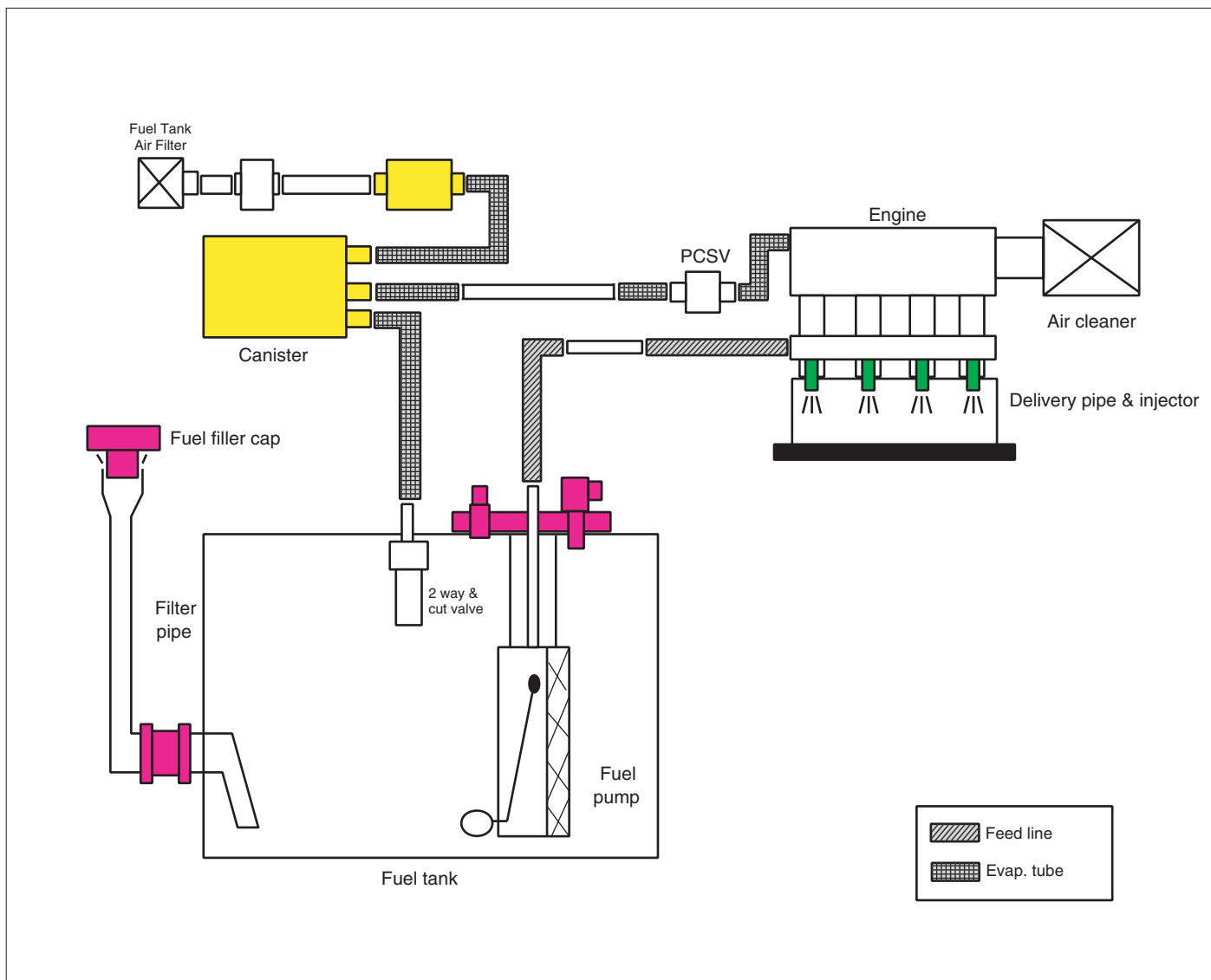

EERF600K

CANISTER

Canister accumulates vapor from fuel tank. PCM controls PCSV to send vapor to intake manifold.

PURGE CONTROL SOLENOID VALVE (PCSV)

PCSV is installed between intake manifold and canister. PCM controls PCSV, which is operated by vacuum, to send vapor in canister to intake manifold.

INSPECTION E75C904E

1. Disconnect the vacuum hose from the throttle body, and connect a vacuum pump to the vacuum hose.
2. Check the following points when the engine is cold [engine coolant temperature 60°C(140°F) or below] and when it is warm [engine coolant temperature 80°C(176°F) or higher].

WHEN ENGINE IS COLD

Engine operating condition	Applied vacuum	Result
Idling	50 kPa (7.3 psi)	Vacuum is held
3,000 rpm		

WHEN ENGINE IS WARM

Engine operating condition	Applied vacuum	Result
Idling	50 kPa (7.3 psi)	Vacuum is held
Within 3 minutes after engine start at 3,000 rpm	Try to apply vacuum	Vacuum is released
After 3 minutes have passed after engine start at 3,000 rpm	50 kPa (7.3 psi)	Vacuum will be held momentarily, after which, it will be released

EVAPORATIVE (EVAP)CANISTER

INSPECTION EE0AE0B5

1. Look for loose connections, sharp bends or damage to the fuel vapor lines.
2. Look for distortion, cracks or fuel damage.
3. After removing the canister, inspect for cracks or damage.

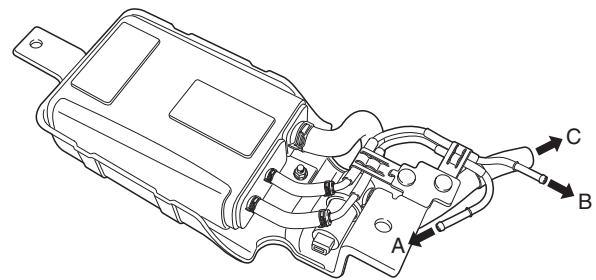

A : Canister ↔ Fuel Tank
 B : Canister ↔ Intake manifold
 C : Canister ↔ Fuel tank air filter

SGHEC7102L

EVAPORATIVE (EVAP) CANISTER PURGE SOLENOID VALVE

5. Measure the resistance between the terminals of the solenoid valve.

INSPECTION ED3BA4CA

PCSV coil resistance(Ω) : 19.0 ~ 22.0 Ω at 20°C (68°F)

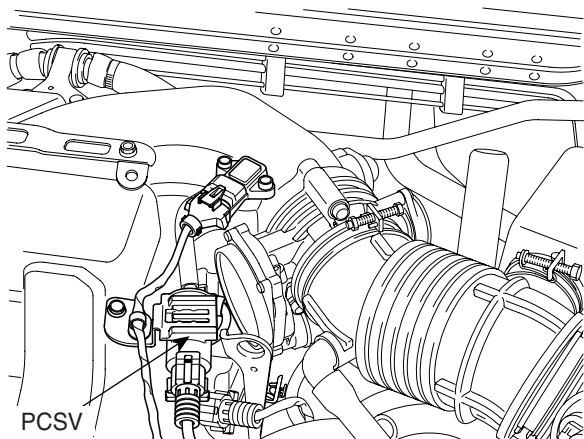

SGHEC7101L

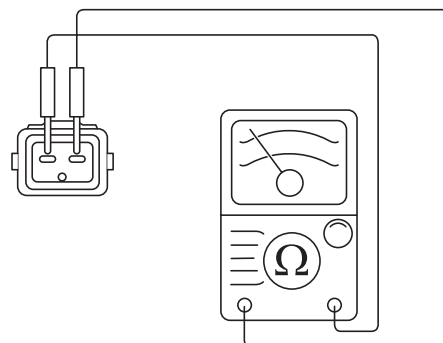

KERE001M

NOTE

When disconnecting the vacuum hose, make an identification mark on it so that it can be reconnected to its original position.

1. Disconnect the vacuum hose from the solenoid valve.
2. Detach the harness connector.
3. Connect a vacuum pump to the nipple to which the red-striped vacuum hose was connected.
4. Apply vacuum and check when voltage is applied to the PCSV and when the voltage is discontinued.

Battery voltage	Normal condition
When applied	Vacuum is released
When discontinued	Vacuum is maintained

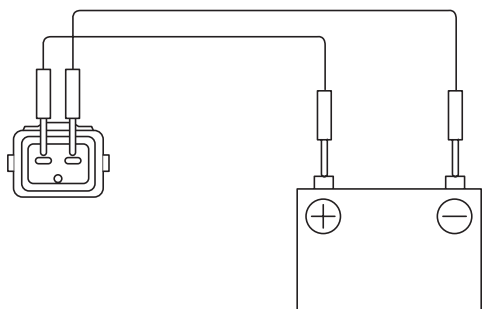

KERE001L

FUEL FILLER CAP

DESCRIPTION EA9E78E3

A ratchet tightening device on the threaded fuel filler cap reduces the chances of incorrect installation, which would

seal the fuel filler. After the gasket on the fuel filler cap and the filler neck flange contact each other, the ratchet produces a loud clicking noise indicating the seal has been set.

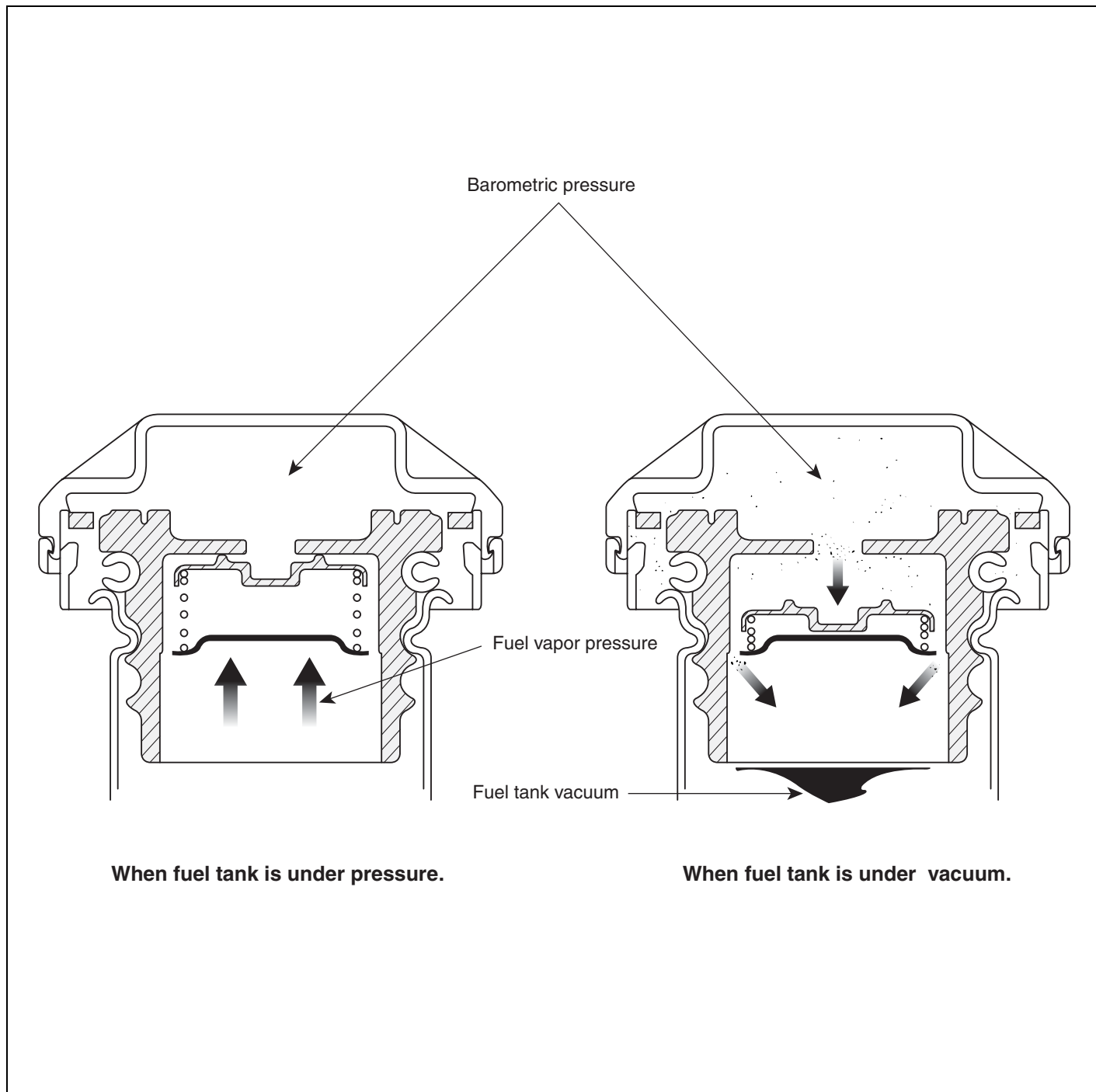

LEGE015A

FUEL TANK AIR FILTER

REPLACEMENT E9CEAA4D

1. Remove the rear left wheel house.
(Refer to "BD" group)
2. Unfasten three mounting nuts (B) and disconnect the canister hose (A).

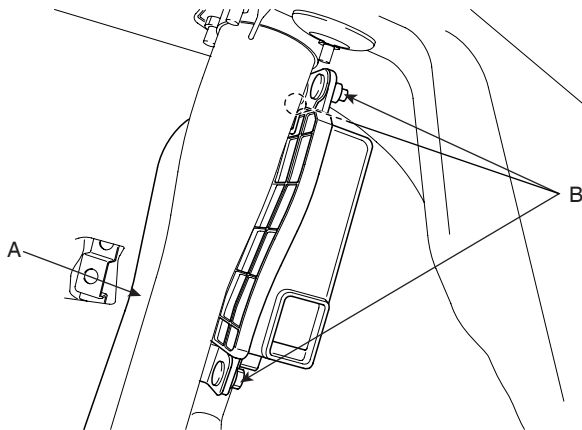

SGHEC6013D

3. Remove the canister air filter.
4. Install a new canister air filter.

EXHAUST EMISSION CONTROL SYSTEM

DESCRIPTION EDCBC6C7

Exhaust emissions (CO, HC, NO_x) are controlled by a combination of engine modifications and the addition of special control components.

Modifications to the combustion chamber, intake manifold, camshaft and ignition system form the basic control system.

These items have been integrated into a highly effective system which controls exhaust emissions while maintaining good driveability and fuel economy.

AIR/FUEL MIXTURE CONTROL SYSTEM [MULTIPOINT FUEL INJECTION (MFI) SYSTEM]

The MFI system is a system which uses the signals from the heated oxygen sensor to activate and control the injector installed in the manifold for each cylinder, thus precisely regulating the air/fuel mixture ratio and reducing emissions.

This in turn allows the engine to produce exhaust gases of the proper composition to permit the use of a three way catalyst. The three way catalyst is designed to convert the three pollutants (1) hydrocarbons (HC), (2) carbon monoxide (CO), and (3) oxides of nitrogen (NO_x) into harmless substances. There are two operating modes in the MFI system.

1. Open Loop air/fuel ratio is controlled by information programmed into the ECM.
2. Closed Loop air/fuel ratio is adjusted by the ECM based on information supplied by the oxygen sensor.

CONTINUOUS VARIABLE VALVE TIMING (CVVT)

DESCRIPTION E2CFED62

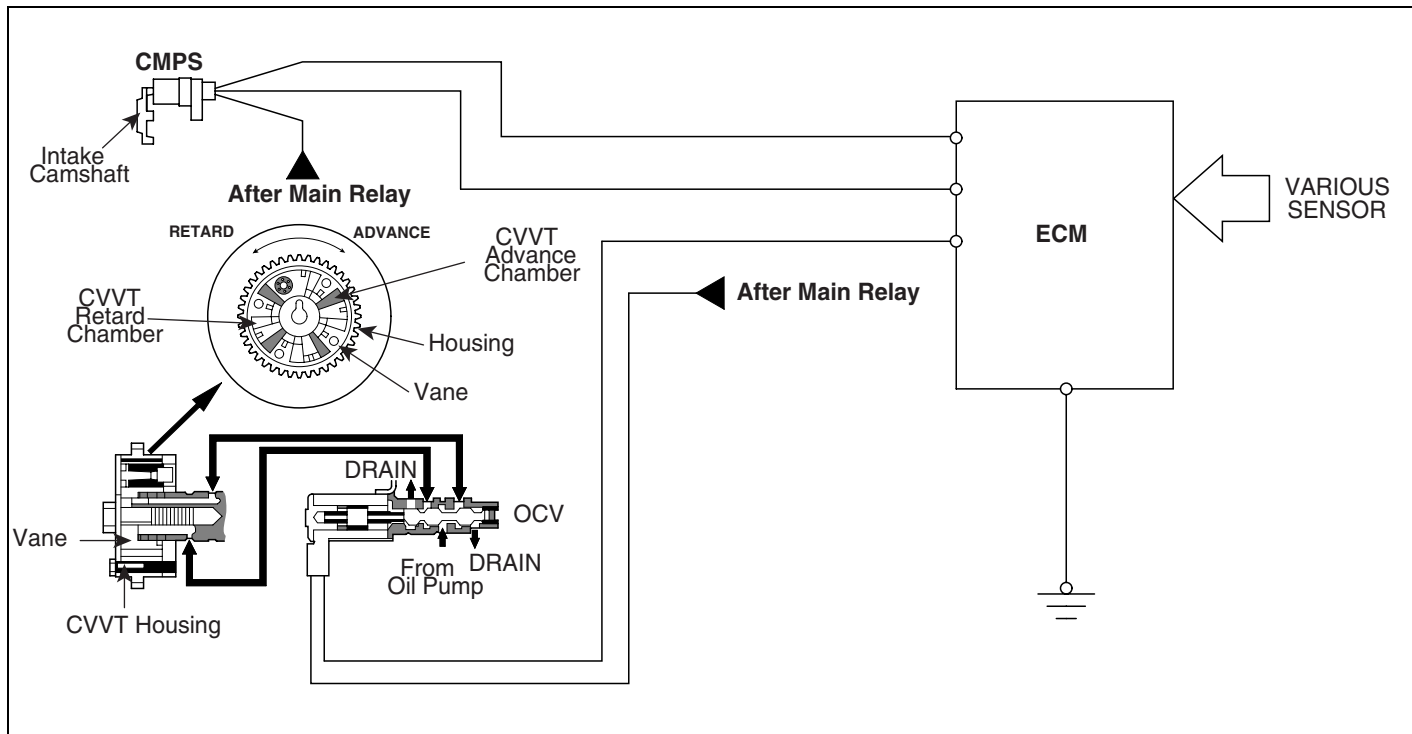

LEIF001P

The CVVT (Continuously Variable Valve Timing) which is installed on the exhaust camshaft controls intake valve open and close timing in order to improve engine performance.

The intake valve timing is optimized by CVVT system depending on engine rpm.

This CVVT system improves fuel efficiency and reduces NOx emissions at all levels of engine speed, vehicle speed, and engine load by EGR effect because of valve over-lap optimization.

The CVVT changes the phase of the intake camshaft via oil pressure.

It changes the intake valve timing continuously.

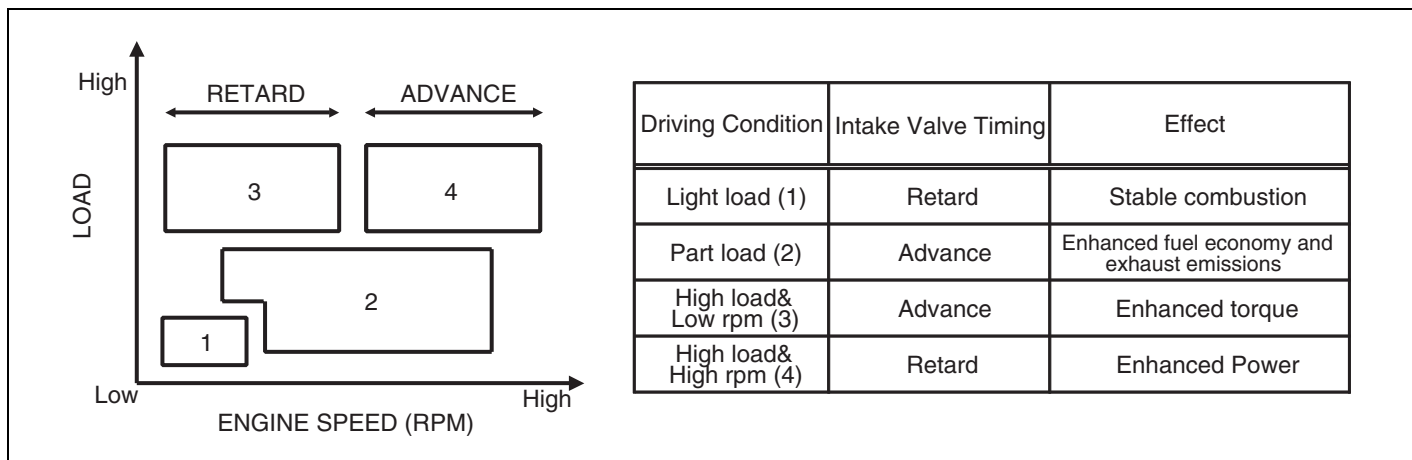

LEIF001Q

OPERATION EA3CCAEB

The CVVT system makes continuous intake valve timing changes based on operating conditions.

Intake valve timing is optimized to allow the engine to produce maximum power.

Cam angle is advanced to obtain the EGR effect and reduce pumping loss. The intake valve is closed quickly to

reduce the entry of the air/fuel mixture into the intake port and improve the changing effect. Reduces the cam advance at idle, stabilizes combustion, and reduces engine speed.

If a malfunction occurs, the CVVT system control is disabled and the valve timing is fixed at the fully retarded position.

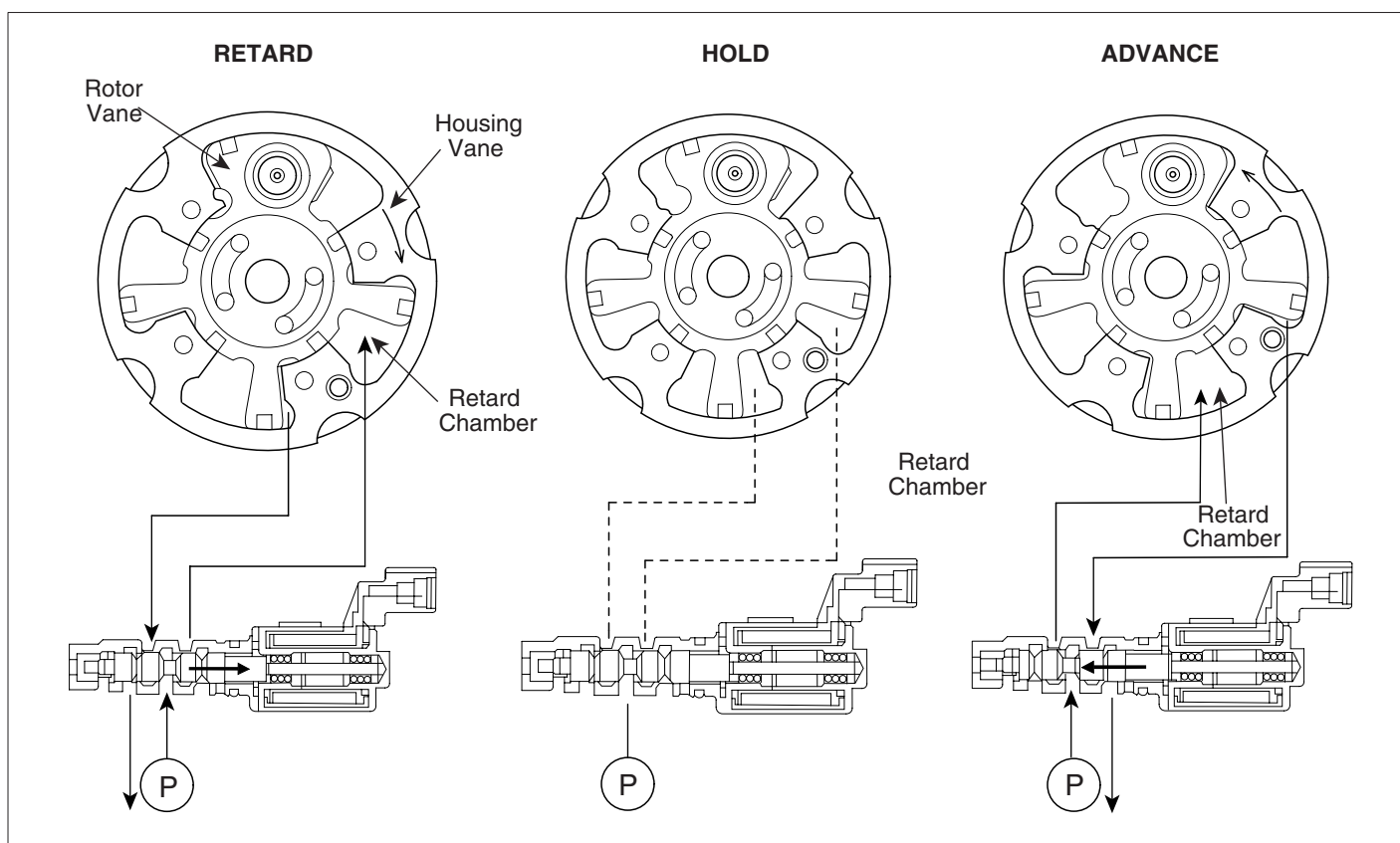
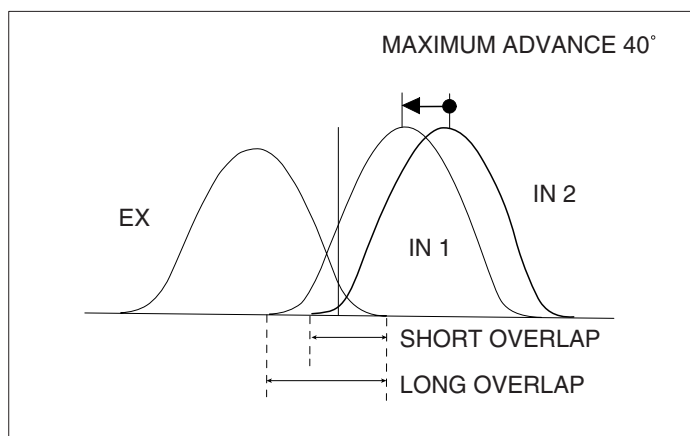
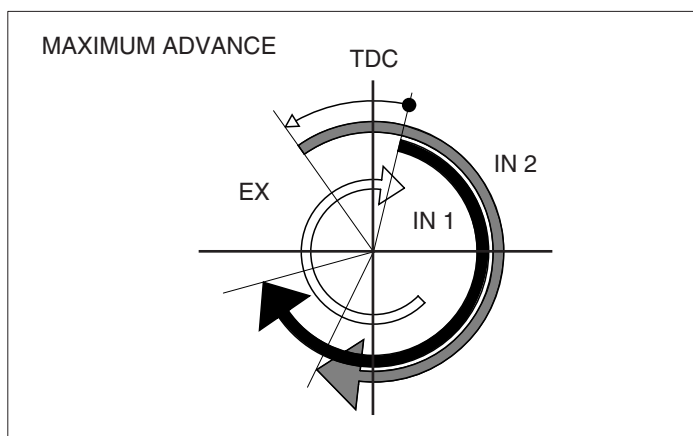

LEJF001R

1. The above figure shows the relative operation structures of the housing vane to the rotor vane.
2. If the CVVT is held a certain control angle, to hold this state, oil is replenished as much as oil leaks from the oil pump.

Be sure there might be a difference in the position according to the engine running state (rpm, oil temperature, and oil pressure).

The OCV (Oil-flow Control Valve) spool location at this time is as follows.

Oil pump → **Advance oil chamber** (Little by little open the inflow side to the advance oil chamber) → **Almost close the drain side**