

# Body Electrical System



# GENERAL

## GENERAL TROUBLESHOOTING INFORMATION

E383DB0F

### BEFORE TROUBLESHOOTING

1. Check applicable fuses in the appropriate fuse/relay box.
2. Check the battery for damage, state of charge, and clean and tight connections.

#### NOTE

- Do not quick-charge a battery unless the battery ground cable has been disconnected, otherwise you will damage the alternator diodes.
- Do not attempt to crank the engine with the battery ground cable loosely connected or you will severely damage the wiring.

3. Check the alternator belt tension.

### HANDLING CONNECTORS

1. Make sure the connectors are clean and have no loose wire terminals.
2. Make sure multiple cavity connectors are packed with grease (except watertight connectors).
3. All connectors have push-down release type locks (A).

4. Some connectors have a clip on their side used to attach them to a mount bracket on the body or on another component. This clip has a pull type lock.
5. Some mounted connectors cannot be disconnected unless you first release the lock and remove the connector from its mount bracket (A).

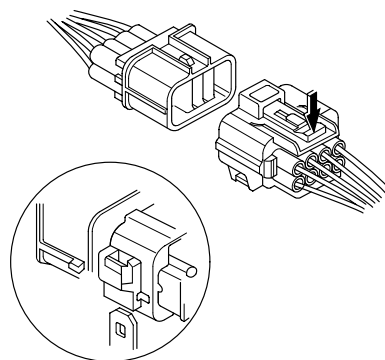

ETKD150B

6. Never try to disconnect connectors by pulling on their wires; pull on the connector halves instead.
7. Always reinstall plastic covers.

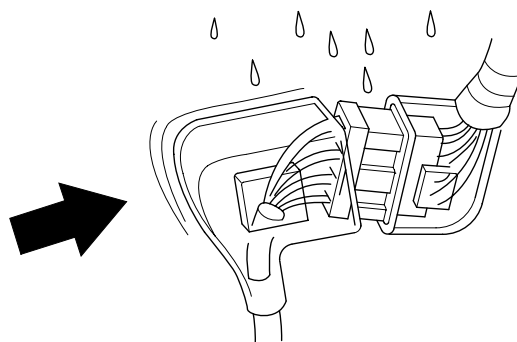

ETKD150C

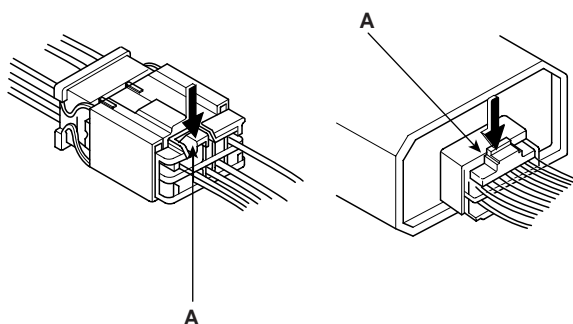

ETKD150A

8. Before connecting connectors, make sure the terminals (A) are in place and not bent.

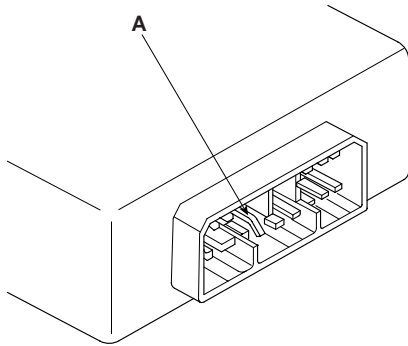

ETKD150D

11. Insert the connector all the way and make sure it is securely locked.

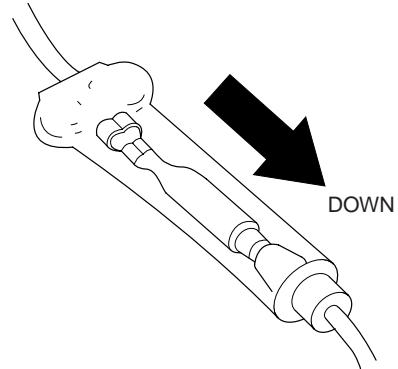

12. Position wires so that the open end of the cover faces down.

9. Check for loose retainer (A) and rubber seals (B).

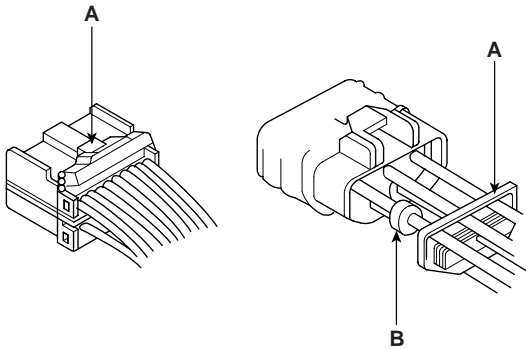

ETKD150E

10. The backs of some connectors are packed with grease. Add grease if necessary. If the grease (A) is contaminated, replace it.

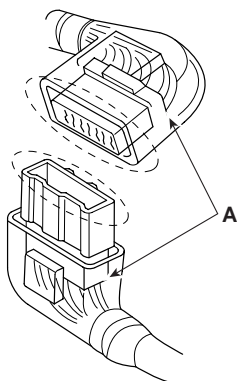

ETKD150F

ETKD150G

### HANDLING WIRES AND HARNESSSES

1. Secure wires and wire harnesses to the frame with their respective wire ties at the designated locations.
2. Remove clips carefully; don't damage their locks (A).

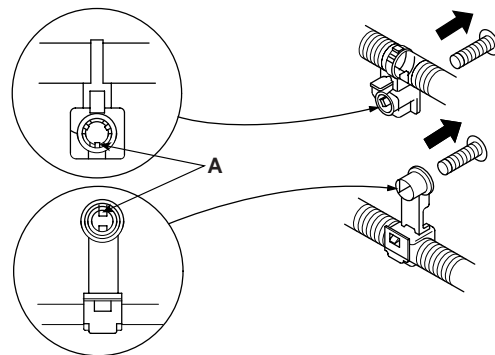

ETKD150H

3. Slip pliers (A) under the clip base and through the hole at an angle, and then squeeze the expansion tabs to release the clip.

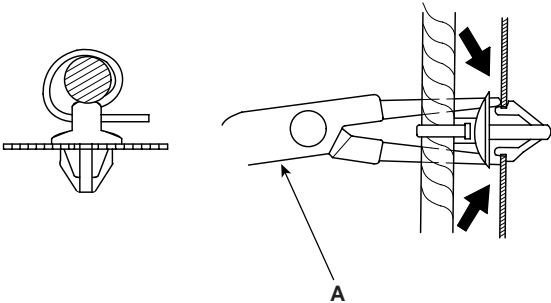

ETKD150I

4. After installing harness clips, make sure the harness doesn't interfere with any moving parts.
5. Keep wire harnesses away from exhaust pipes and other hot parts, from sharp edges of brackets and holes, and from exposed screws and bolts.
6. Seat grommets in their grooves properly (A). Do not leave grommets distorted (B).

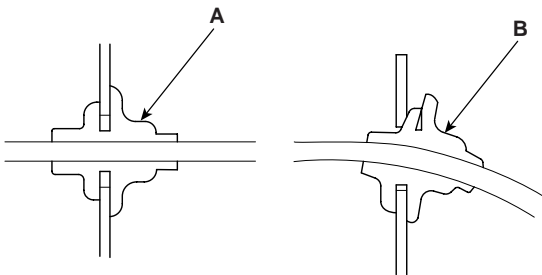

ETKD150J

TESTING AND REPAIRS

1. Do not use wires or harnesses with broken insulation. Replace them or repair them by wrapping the break with electrical tape.
2. After installing parts, make sure that no wires are pinched under them.
3. When using electrical test equipment, follow the manufacturer's instructions and those described in this manual.
4. If possible, insert the probe of the tester from the wire side (except waterproof connector).

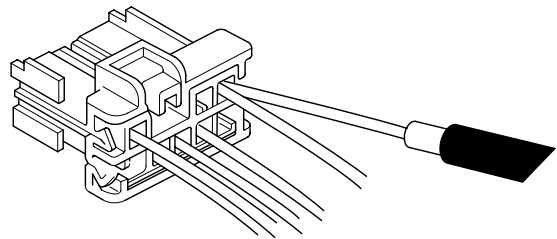

ETKD150K

5. Use a probe with a tapered tip.

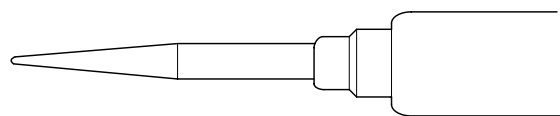

ETKD150L

**FIVE-STEP TROUBLESHOOTING**

1. Verify the complaint  
Turn on all the components in the problem circuit to verify the customer complaint. Note the symptoms. Do not begin disassembly or testing until you have narrowed down the problem area.
2. Analyze the schematic  
Look up the schematic for the problem circuit. Determine how the circuit is supposed to work by tracing the current paths from the power feed through the circuit components to ground. If several circuits fail at the same time, the fuse or ground is a likely cause. Based on the symptoms and your understanding of the circuit operation, identify one or more possible causes of the problem.
3. Isolate the problem by testing the circuit.  
Make circuit tests to check the diagnosis you made in step 2. Keep in mind that a logical, simple procedure is the key to efficient troubleshooting. Test for the most likely cause of failure first. Try to make tests at points that are easily accessible.
4. Fix the problem  
Once the specific problem is identified, make the repair. Be sure to use proper tools and safe procedures.
5. Make sure the circuit works  
Turn on all components in the repaired circuit in all modes to make sure you've fixed the entire problem. If the problem was a blown fuse, be sure to test all of the circuits on the fuse. Make sure no new problems turn up and the original problem does not recur.

**TROUBLESHOOTING** E9CF2D32

**INSTRUMENTS AND WARNING SYSTEM**

Symptom	Possible cause	Remedy
Speedometer does not operate	Cluster fuse (10A) blown	Check for short and replace fuse
	Speedometer faulty	Check speedometer
	Vehicle speed sensor faulty	Check vehicle speed sensor
	Wiring or ground faulty	Repair if necessary
Tachometer does not operate	Cluster fuse (10A) blown	Check for short and replace fuse
	Tachometer faulty	Check tachometer
	Wiring or ground faulty	Repair if necessary
Fuel gauge does not operate	Cluster fuse (10A) blown	Check for short and replace fuse
	Fuel gauge faulty	Check gauge
	Fuel sender faulty	Check fuel sender
	Wiring or ground faulty	Repair if necessary
Low fuel warning lamp does not light up	Cluster fuse (10A) blown	Check for short and replace fuse
	Bulb burned out	Replace bulb
	Fuel sender faulty	Check fuel sender
	Wiring or ground faulty	Repair if necessary
Water temperature gauge does not operate	Cluster fuse (10A) blown	Check for short and replace fuse
	Water temperature gauge faulty	Check gauge
	Water temperature sender faulty	Check sender
	Wiring or ground faulty	Repair if necessary
Oil pressure warning lamp does not light up	Cluster fuse (10A) blown	Check for short and replace fuse
	Bulb burned out	Replace bulb
	Oil pressure switch faulty	Check switch
	Wiring or ground faulty	Repair if necessary
Parking brake warning lamp does not light up	Cluster fuse (10A) blown	Check for short and replace fuse
	Bulb burned out	Replace bulb
	Brake fluid level warning switch faulty	Check switch
	Parking brake switch faulty	Check switch
	Wiring or ground faulty	Repair if necessary
Open door warning lamp and trunk lid warning lamp do not light up	Room lamp fuse (10A) blown	Check for short and replace fuse
	Bulb burned out	Replace bulb
	Door switch faulty	Check switch
	Wiring or ground faulty	Repair if necessary
Seat belt warning lamp does not light up	Cluster fuse (10A) blown	Check for short and replace fuse
	Bulb burned out	Replace bulb
	Seat belt switch faulty	Check switch
	Wiring or ground faulty	Repair if necessary

LIGHTING SYSTEM

Symptom	Possible cause	Remedy
One lamp does not light (all exterior)	Bulb burned out	Replace bulb
	Socket, wiring or ground faulty	Repair if necessary
Head lamps do not light	Bulb burned out	Replace bulb
	Ignition fuse (LOW:10A, HIGH:20A) blown	Check for short and replace fuse
	Head lamp fuse (15A) blown	Check for short and replace fuse
	Head lamp relay faulty	Check relay
	Lighting switch faulty	Check switch
	Wiring or ground faulty	Repair if necessary
Tail lamps and license plate lamps do not light	Bulb burned out	Replace bulb
	Position lamp fuse (10A) blown	Check for short and replace fuse
	Tail lamp relay faulty	Check relay
	Lighting switch faulty	Check switch
	Wiring or ground faulty	Repair if necessary
Stop lamps do not light	Bulb burned out	Replace bulb
	Stop lamp fuse (15A) blown	Check for short and replace fuse
	Stop lamp switch faulty	Adjust or replace switch
	Wiring or ground faulty	Repair if necessary
Stop lamps do not turn off	Stop lamp switch faulty	Repair or replace switch
Instrument lamps do not light (Tail lamps light)	Rheostat faulty	Check rheostat
	Wiring or ground faulty	Repair if necessary
Turn signal lamp does not flash on one side	Bulb burned out	Replace bulb
	Turn signal switch faulty	Check switch
	Wiring or ground faulty	Repair if necessary
Turn signal lamps do not light	Bulb burned out	Replace bulb
	Turn signal lamp fuse (10A) blown	Check for short and replace fuse
	ETACS faulty	Check ETACS
	Turn signal switch faulty	Check switch
	Wiring or ground faulty	Repair if necessary
Hazard warning lamps do not light	Bulb burned out	Replace bulb
	Hazard warning lamp fuse (10A) blown	Check for short and replace fuse
	ETACS faulty	Check ETACS
	Hazard switch faulty	Check switch
	Wiring or ground faulty	Repair if necessary
Flasher rate too slow or too fast	Lamps' wattages are smaller or larger than specified	Replace lamps
	ETACS faulty	Check ETACS

Symptom	Possible cause	Remedy
Back up lamps do not light	Bulb burned out	Replace bulb
	Turn signal lamp fuse (10A) blown	Check for short and replace fuse
	Back up lamp switch (M/T) faulty	Check switch
	Transaxle range switch (A/T) faulty	Check switch
	Wiring or ground faulty	Repair if necessary
Room lamp does not light	Bulb burned out	Replace bulb
	Room lamp fuse (15A) blown	Check for short and replace fuse
	Room lamp switch faulty	Check switch
	Wiring or ground faulty	Repair if necessary
Front fog lamps do not light	Bulb burned out	Replace bulb
	Front fog lamp fuse (15A) blown	Check for short and replace fuse
	Front fog lamp relay faulty	Check relay
	Front fog lamp switch faulty	Check switch
	Wiring or ground faulty	Repair if necessary
Rear fog lamps do not light	Bulb burned out	Replace bulb
	Rear fog lamp fuse (10A) blown	Check for short and replace fuse
	Rear fog lamp fuse (15A) blown	Check for short and replace fuse
	Rear fog lamp switch faulty	Check switch
	Rear fog lamp relay faulty	Check relay
	Wiring or ground faulty	Repair if necessary
Map lamp does not light	Bulb burned out	Replace bulb
	Room lamp fuse (10A) blown	Check for short and replace fuse
	Map lamp switch faulty	Check switch
	Wiring or ground faulty	Repair if necessary
Tailgate room lamp does not light	Bulb burned out	Replace bulb
	Room lamp fuse (10A) blown	Check for short and replace fuse
	Tailgate switch faulty	Check switch
	Wiring or ground faulty	Repair if necessary

**AUDIO SYSTEM**

There are six areas where a problem can occur: wiring harness, the radio, the cassette tape deck, the CD player, and speaker. Troubleshooting enables you to confine the problem to a particular area.

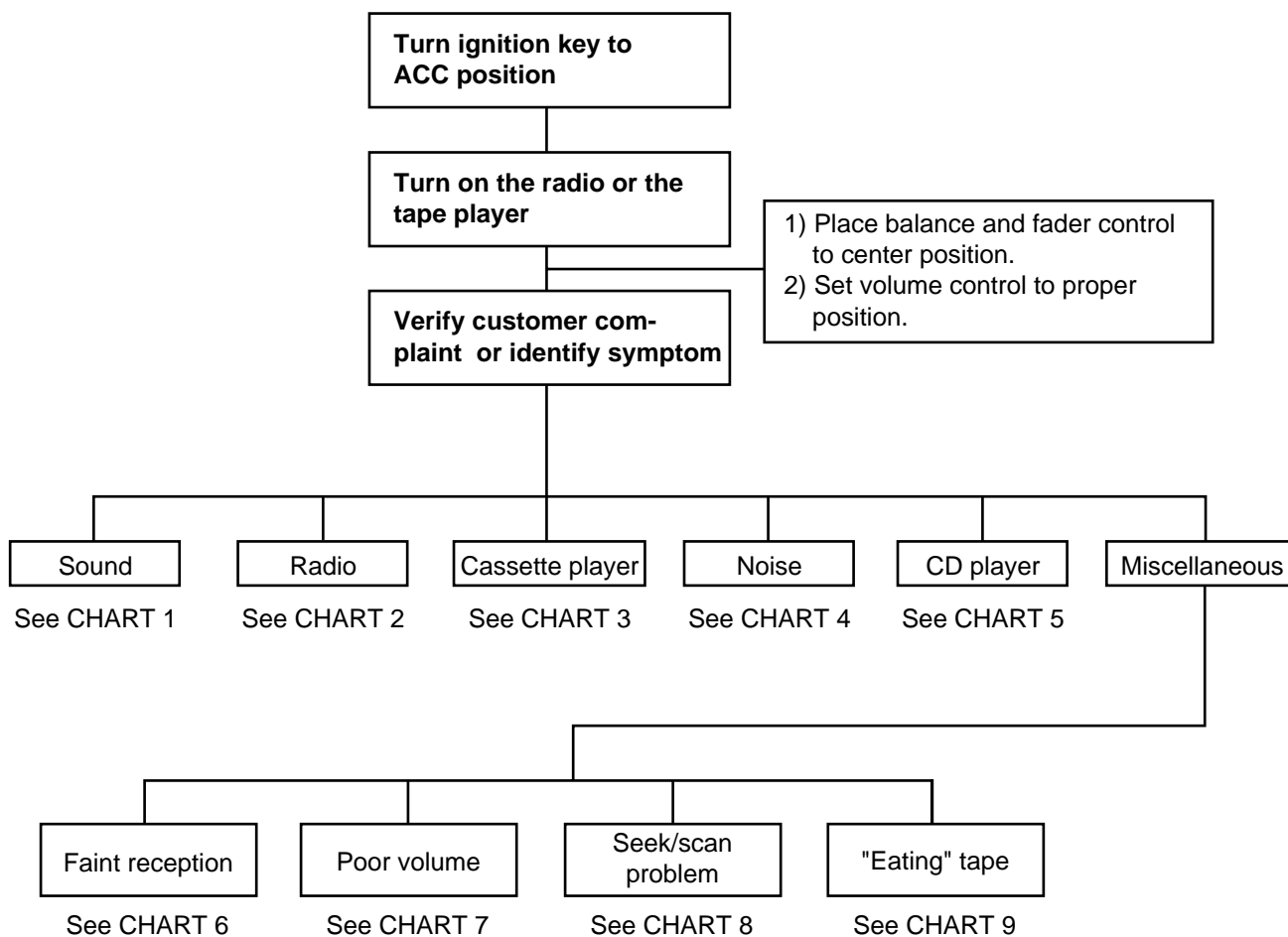

LTIF001A

CHART 1

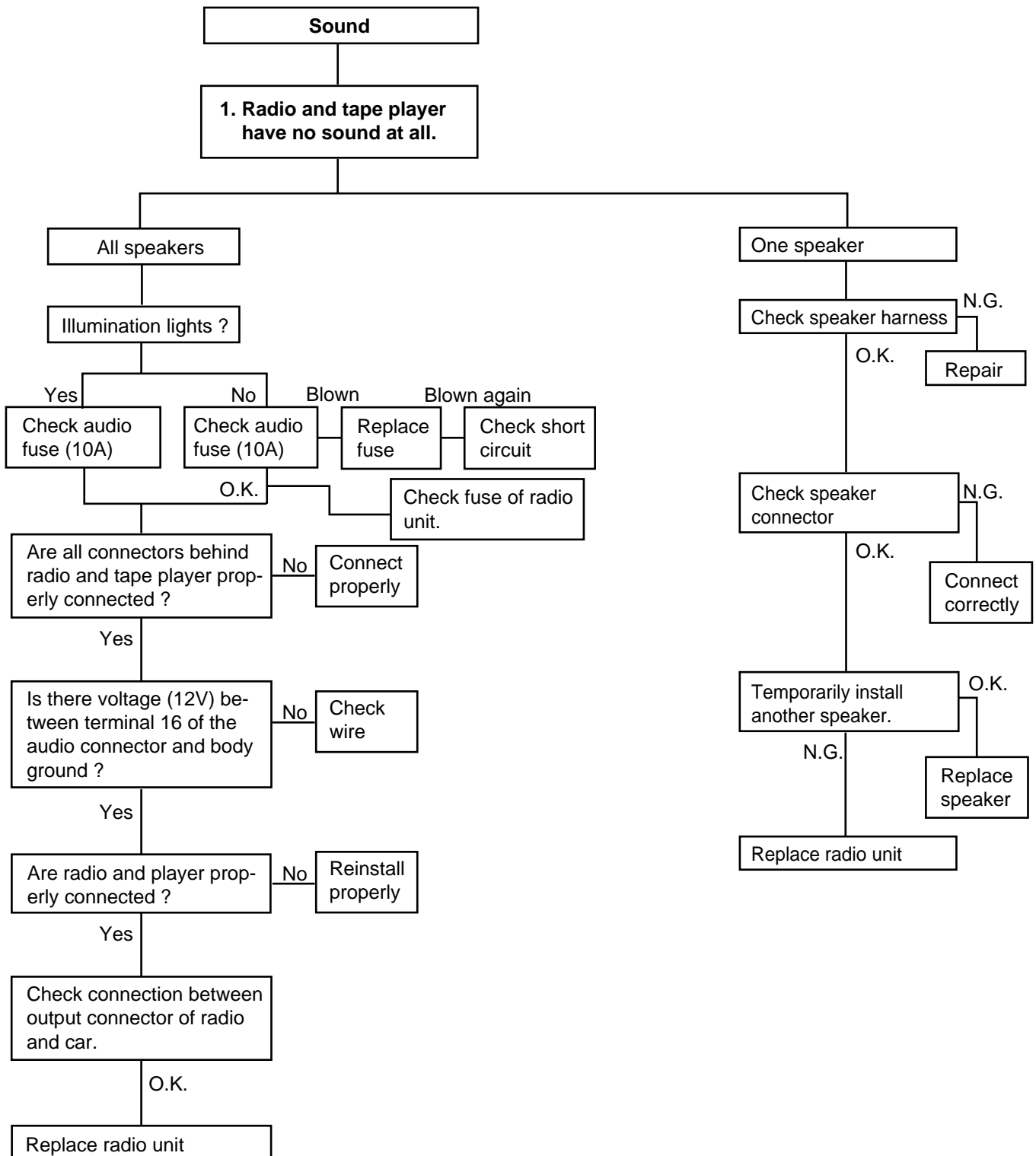

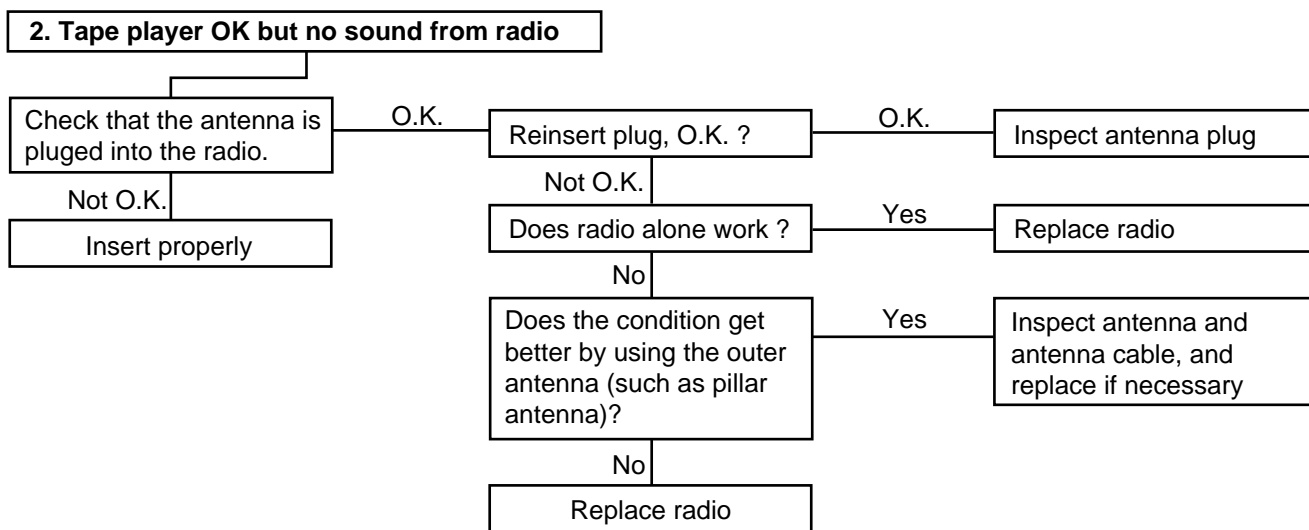

LTIF001C

CHART 2

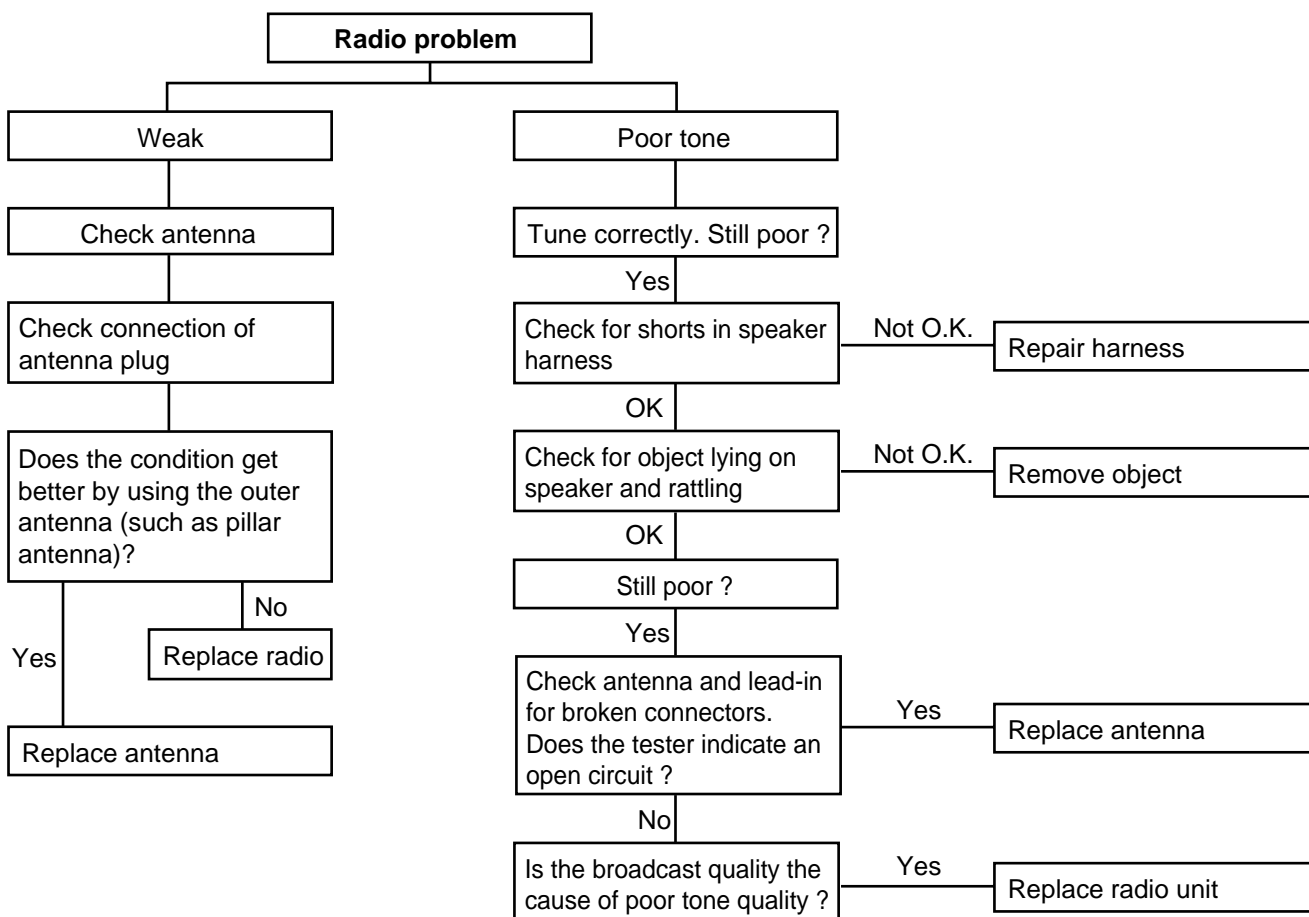

LTIF001D

CHART 3

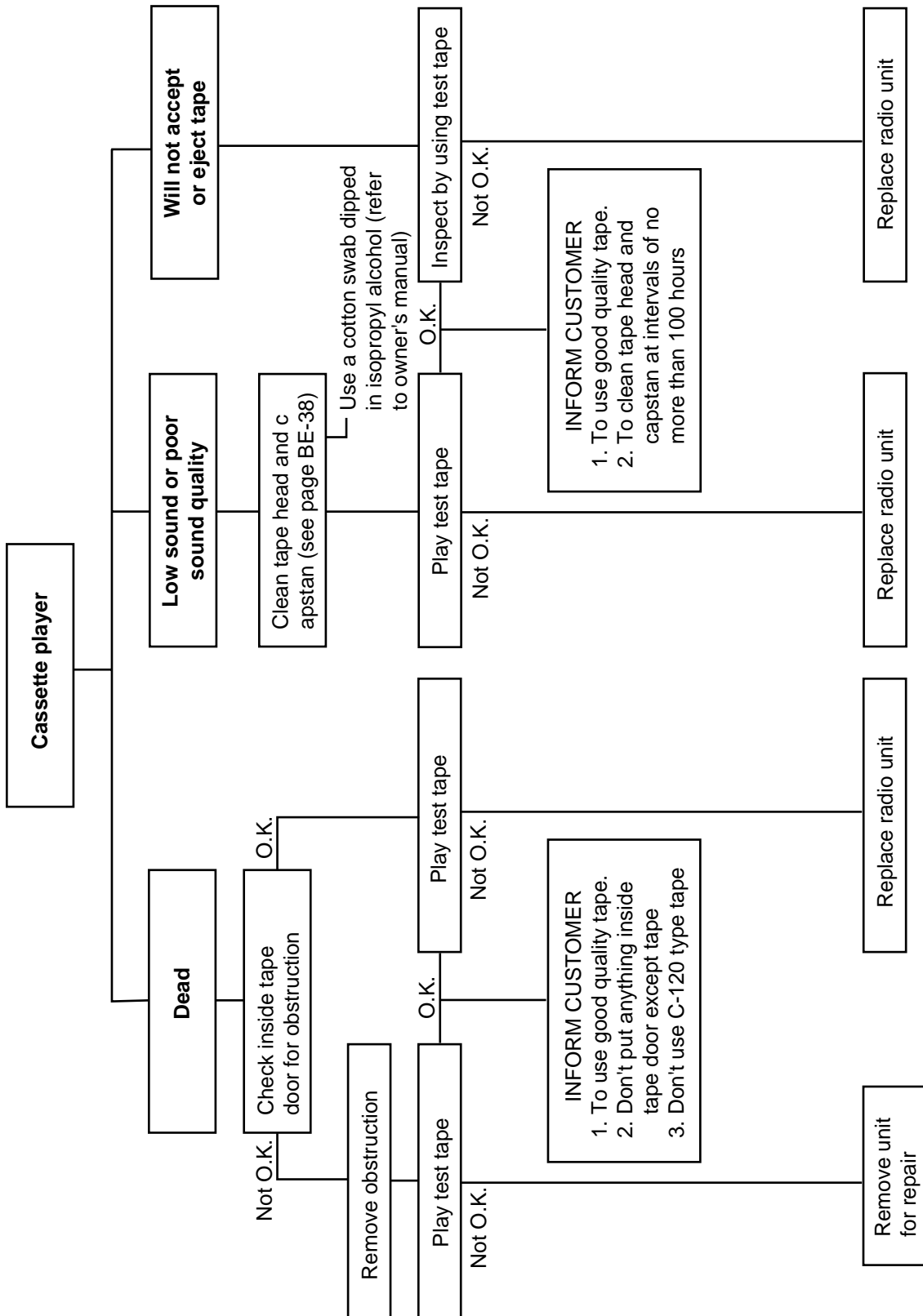
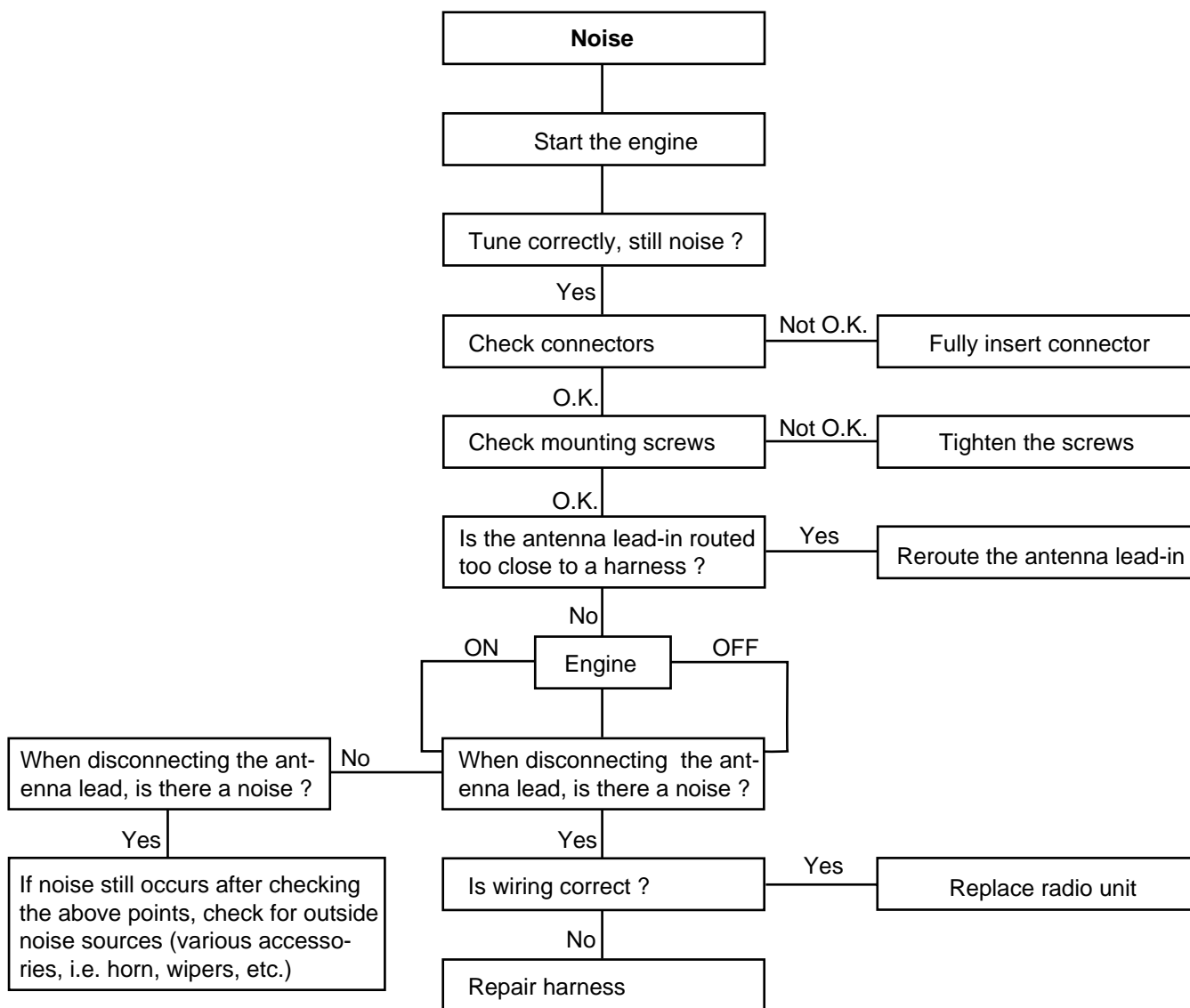

CHART 4

1. RADIO



LTIF001F

2. TAPE

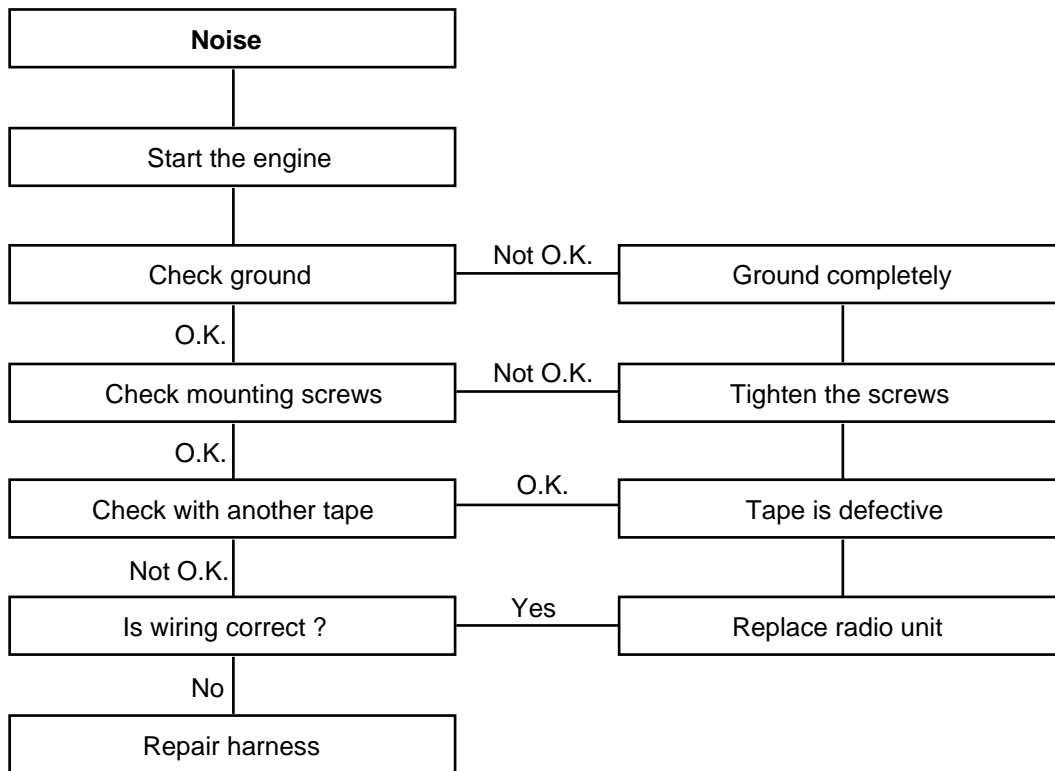

LTIF001G

CHART 5

1. CD WILL NOT BE ACCEPTED

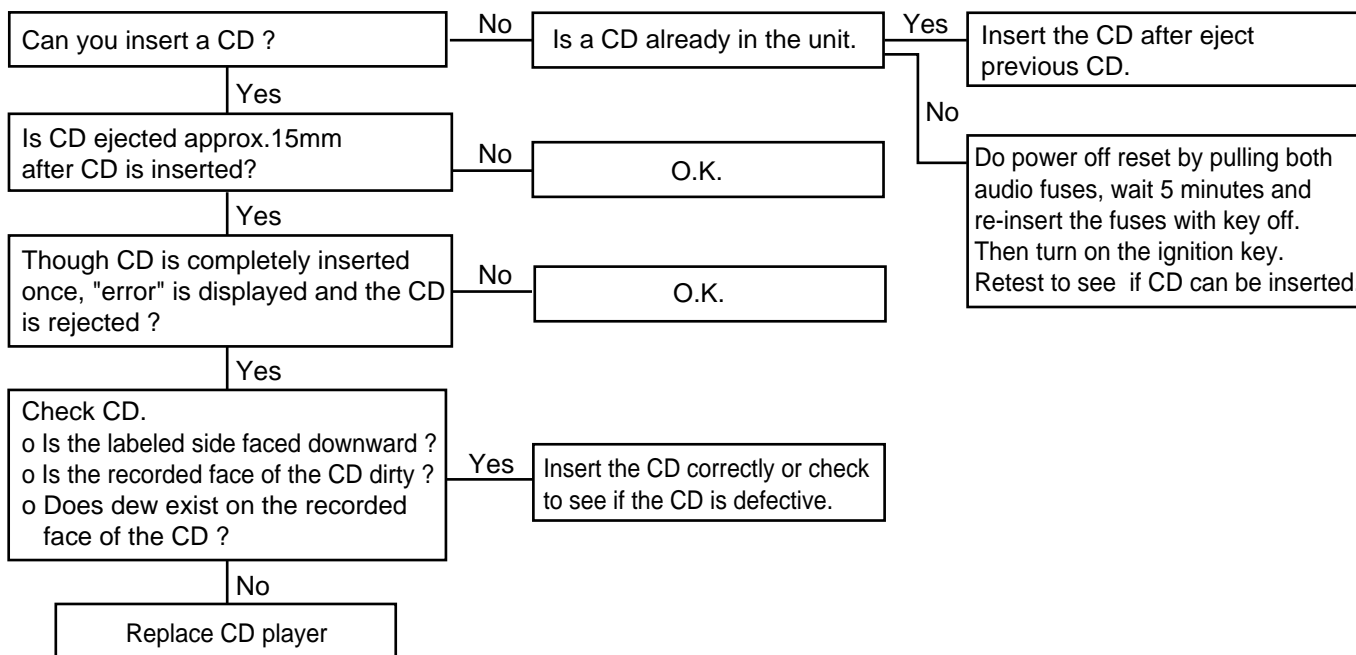

LTIF001H

2. NO SOUND

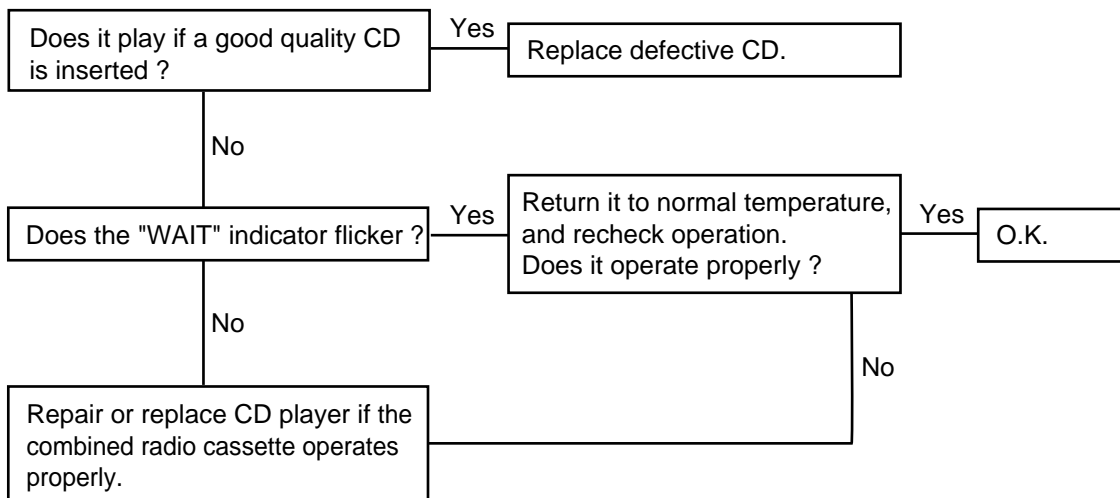

LTIF0011

3. CD SOUND SKIPS

1) Sound sometimes skips when parking.

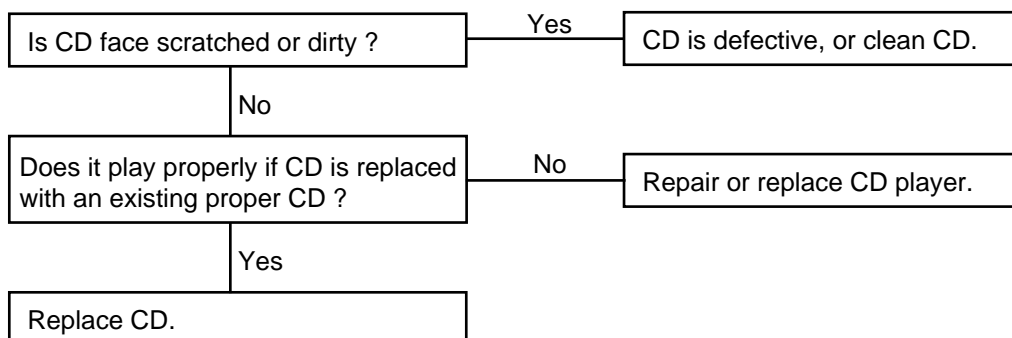

2) Sound sometimes skips when driving.

(Stop vehicle, and check it.)

(Check by using a CD which is free of scratches, dirt or other damage.)

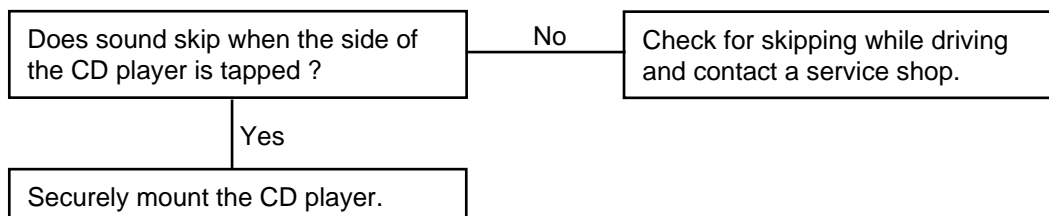

LTIF001J

4. SOUND QUALITY IS POOR

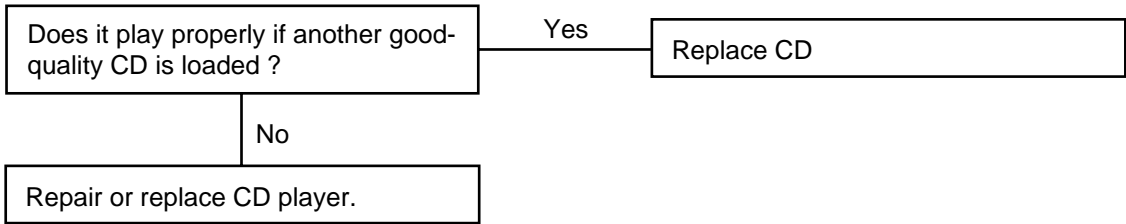

5. CD WILL NOT EJECT

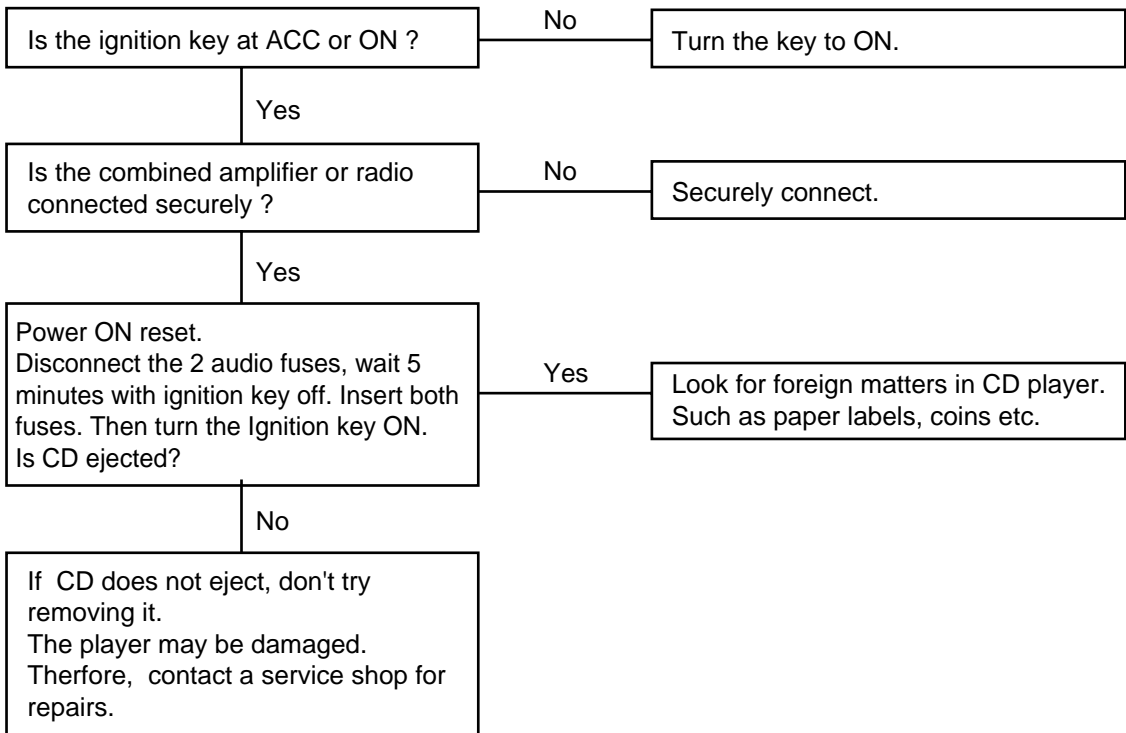

6. NO SOUND FROM ONE SPEAKER

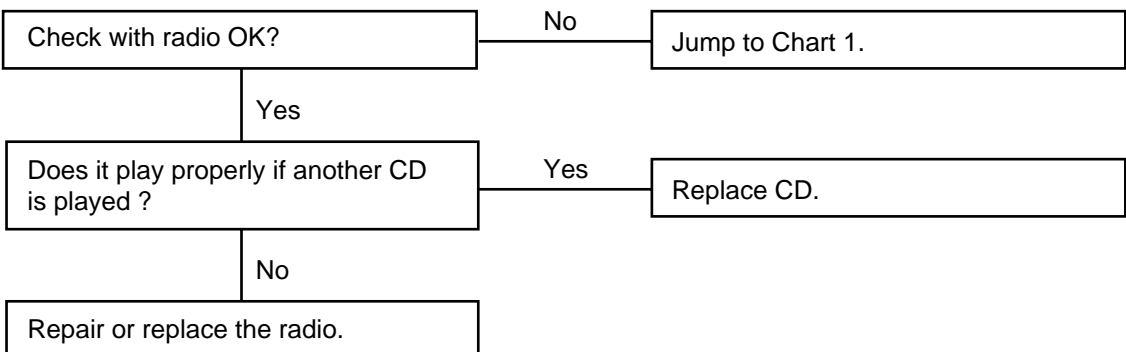
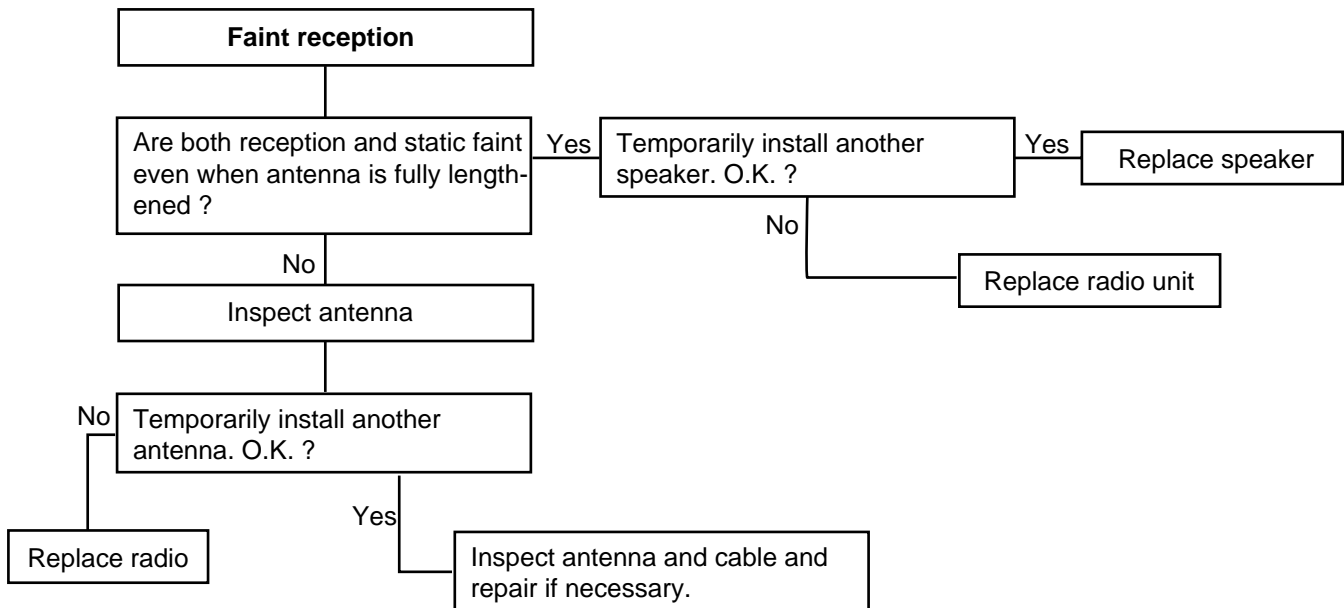
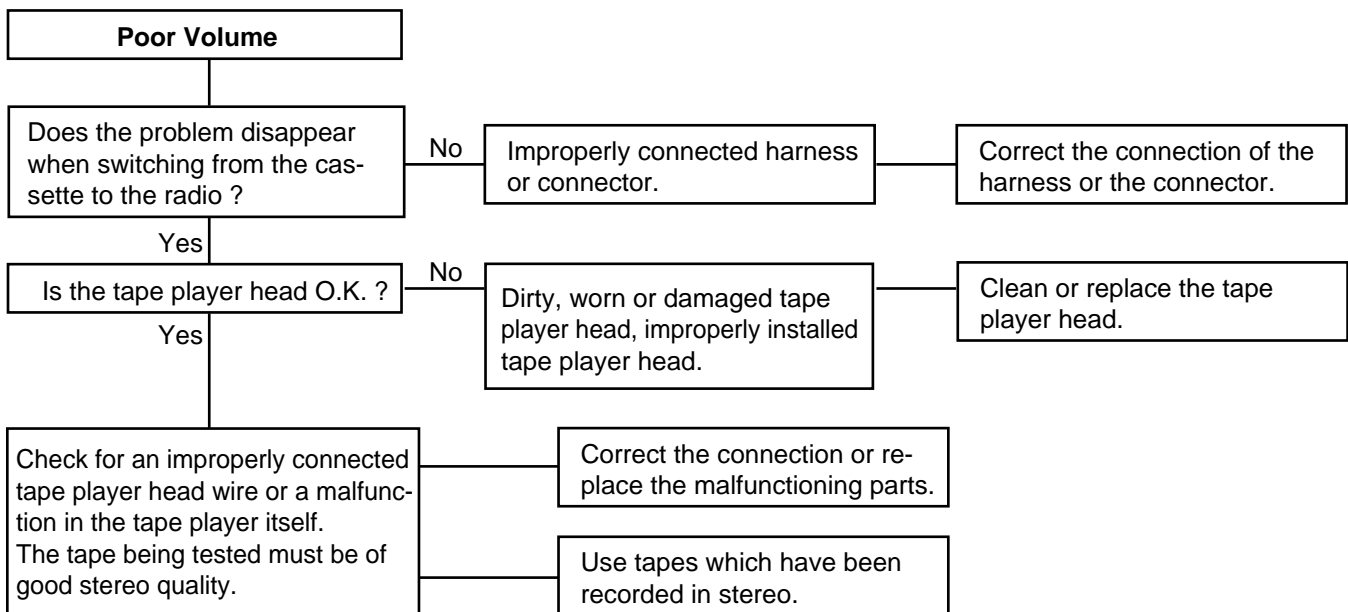

CHART 6



LTIF001L

CHART 7



LTIF001M

CHART 8

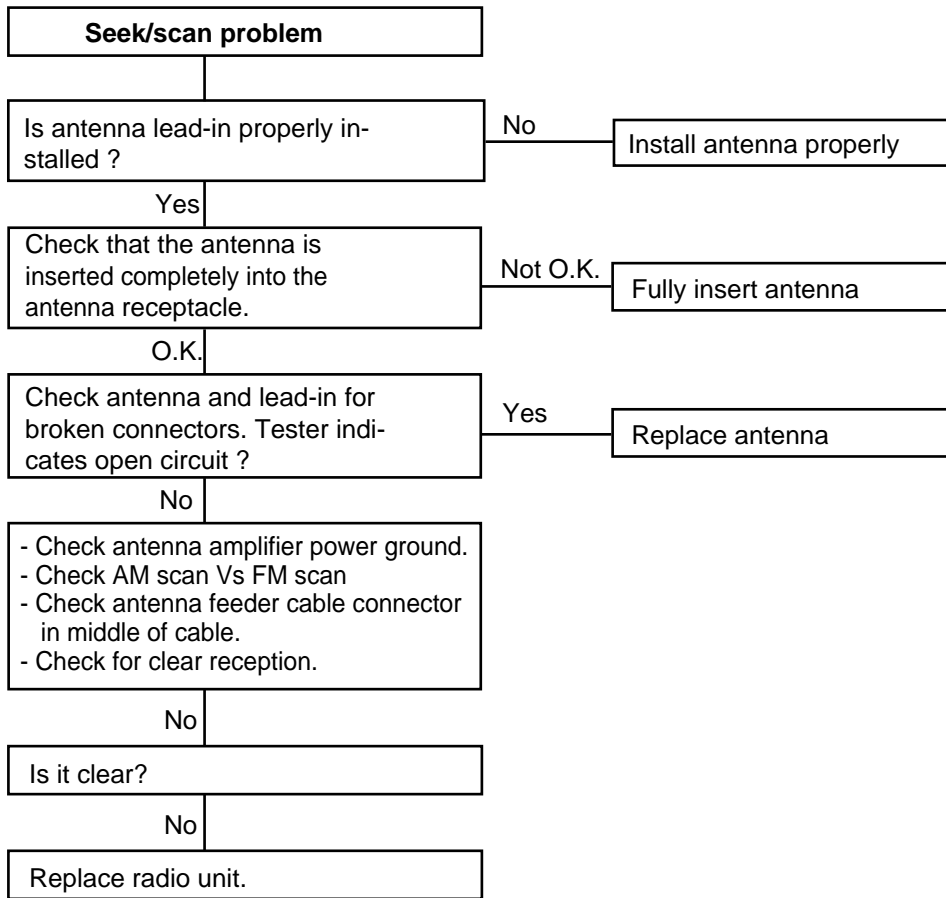

LTIF001N

CHART 9

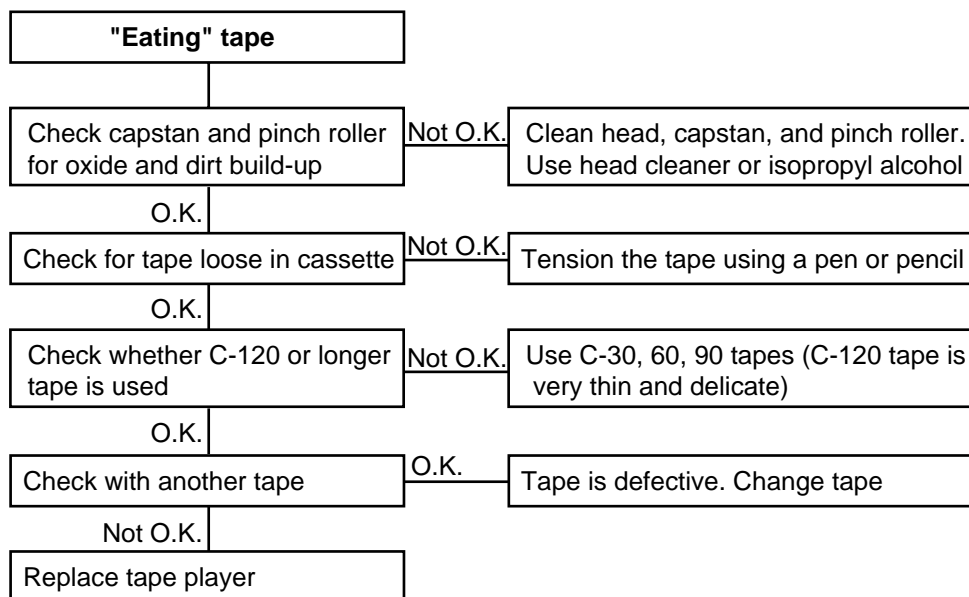

LTIF001O

WINDSHIELD WIPER

1. Wiper low and wiper high do not work.

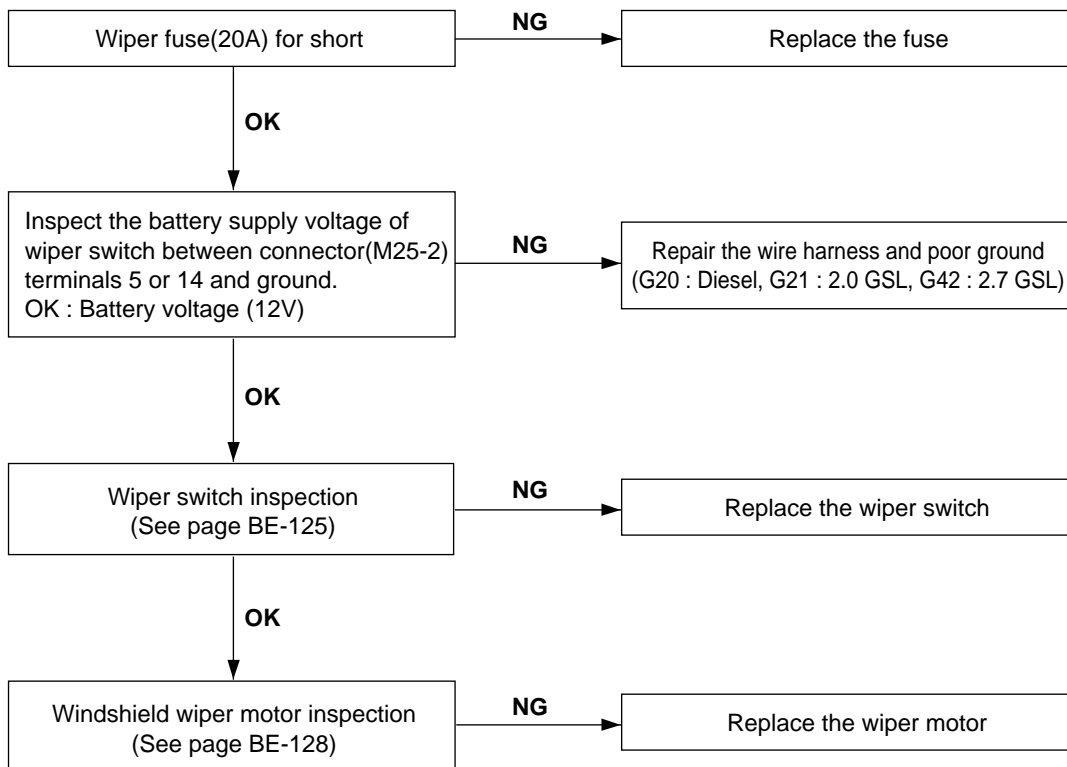

LTIF900A

2. When washer switch is on, wiper does not work.

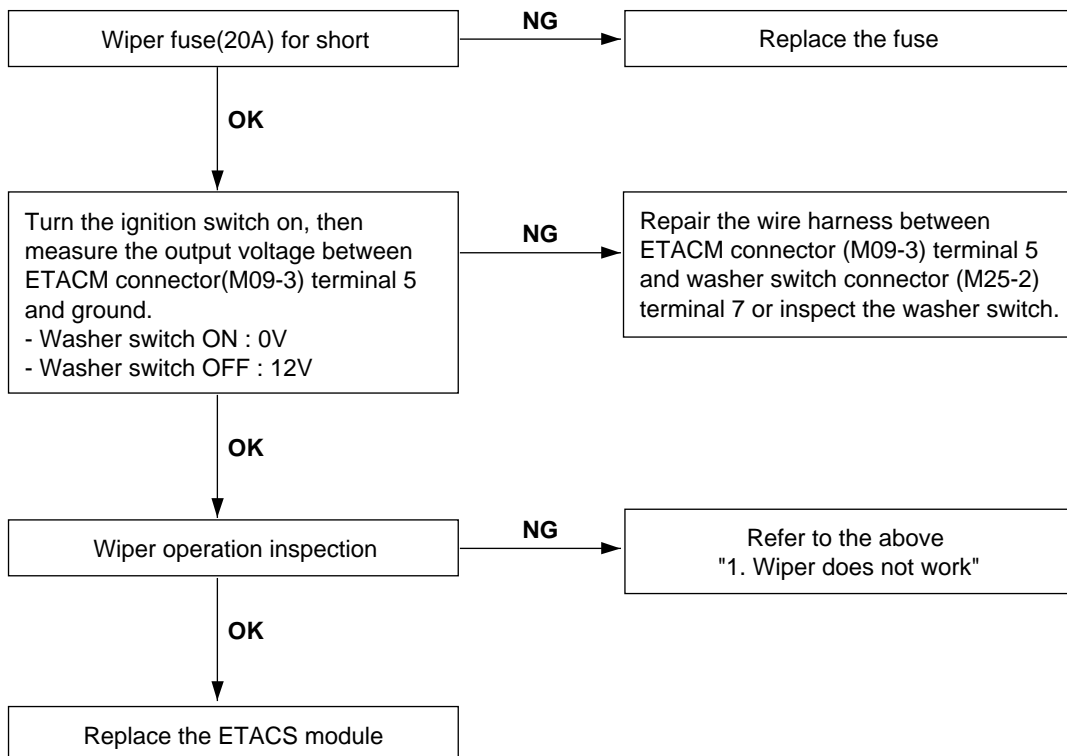

LTIF900B

POWER WINDOW

1. No windows operate from the main switch on the driver's door.

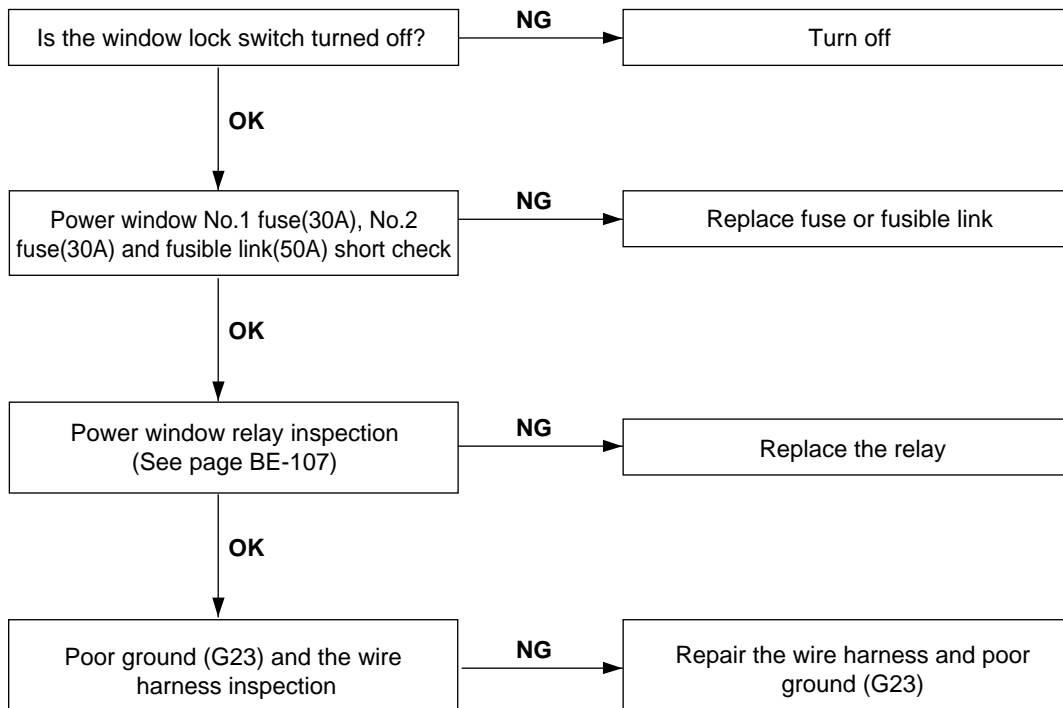

LTIF900C

2. Driver's side window does not operate.

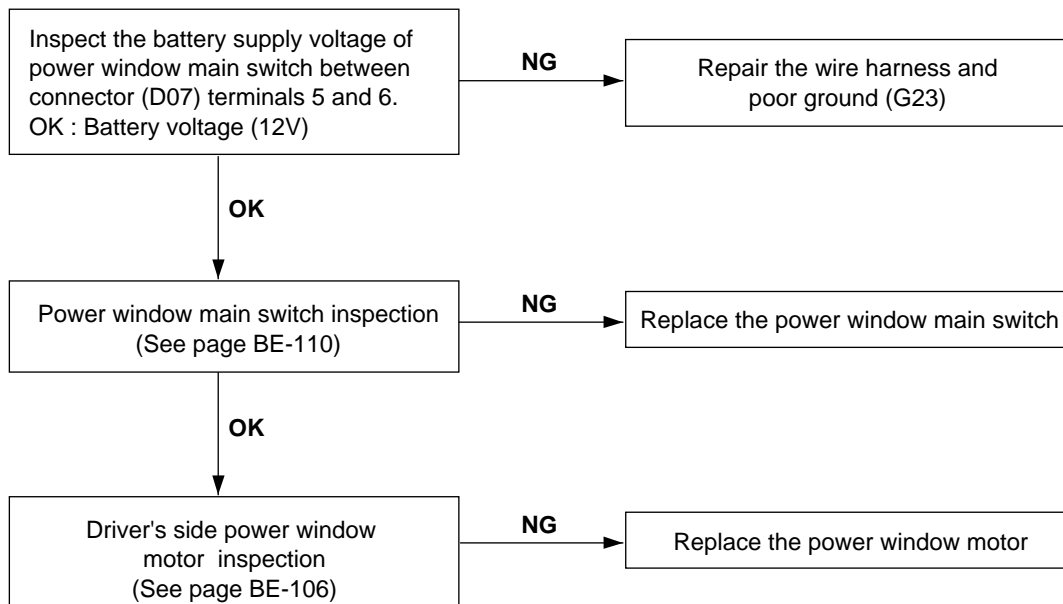

LTIF900D

3. Passenger's side window does not operate.

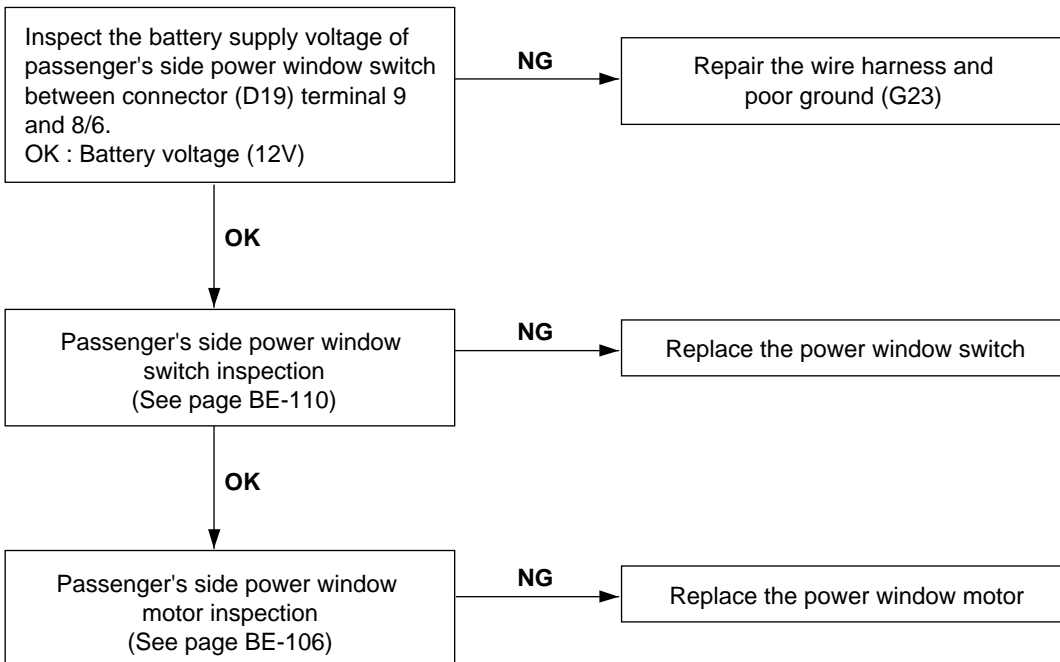

LTIF900E

POWER DOOR LOCK

1. Lock function works but unlock function does not work. Since door unlock relay is fail, replace the door unlock relay.
2. Unlock function works but lock function does not work. Since door lock relay is fail, replace the door lock relay.
3. When passenger side knob is controlled, all doors locks, but when driver side knob is controlled, all doors do not lock.

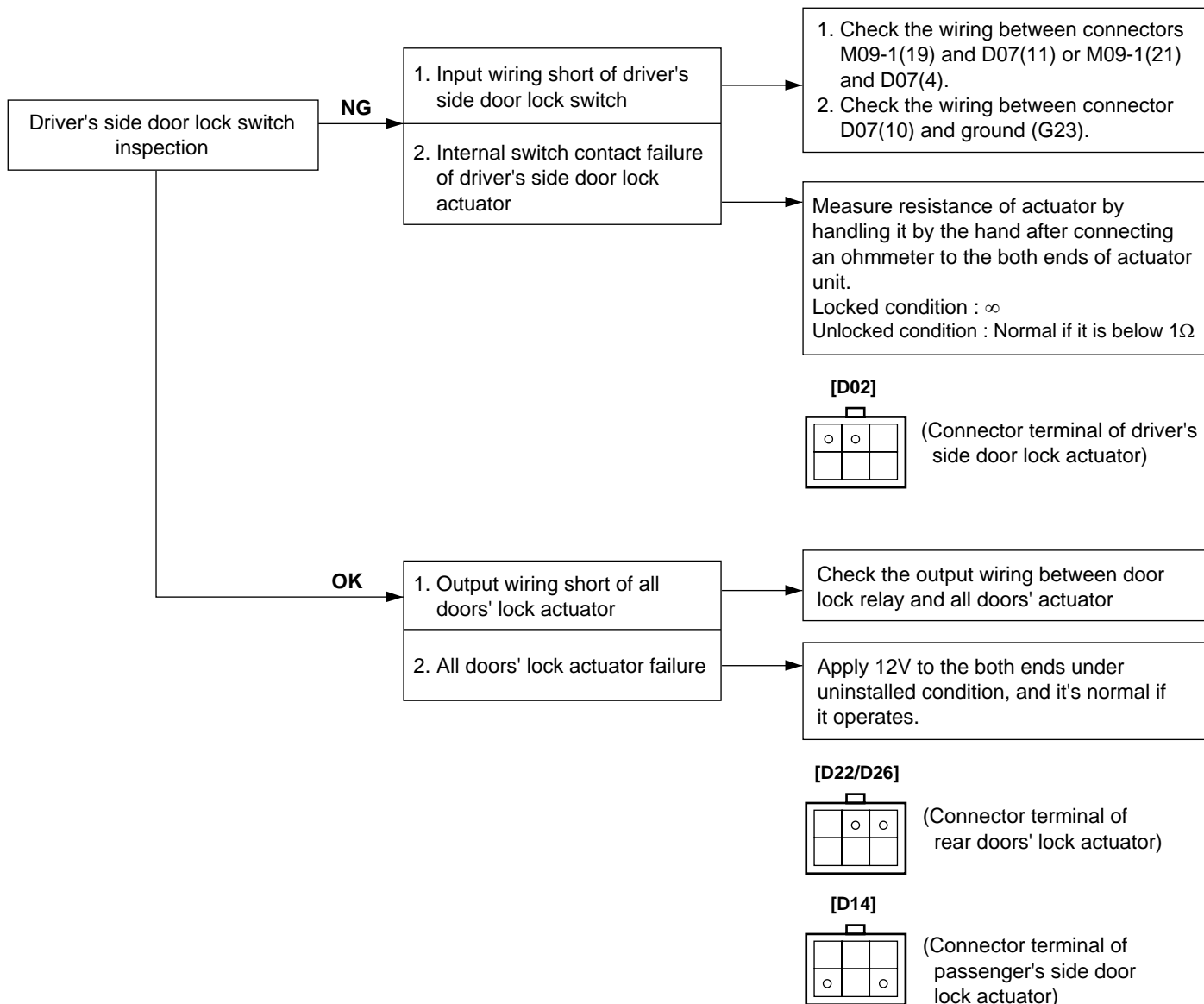

4. When passenger side knob is controlled. All doors lock. But when the driver side knob is controlled, all doors do not lock.

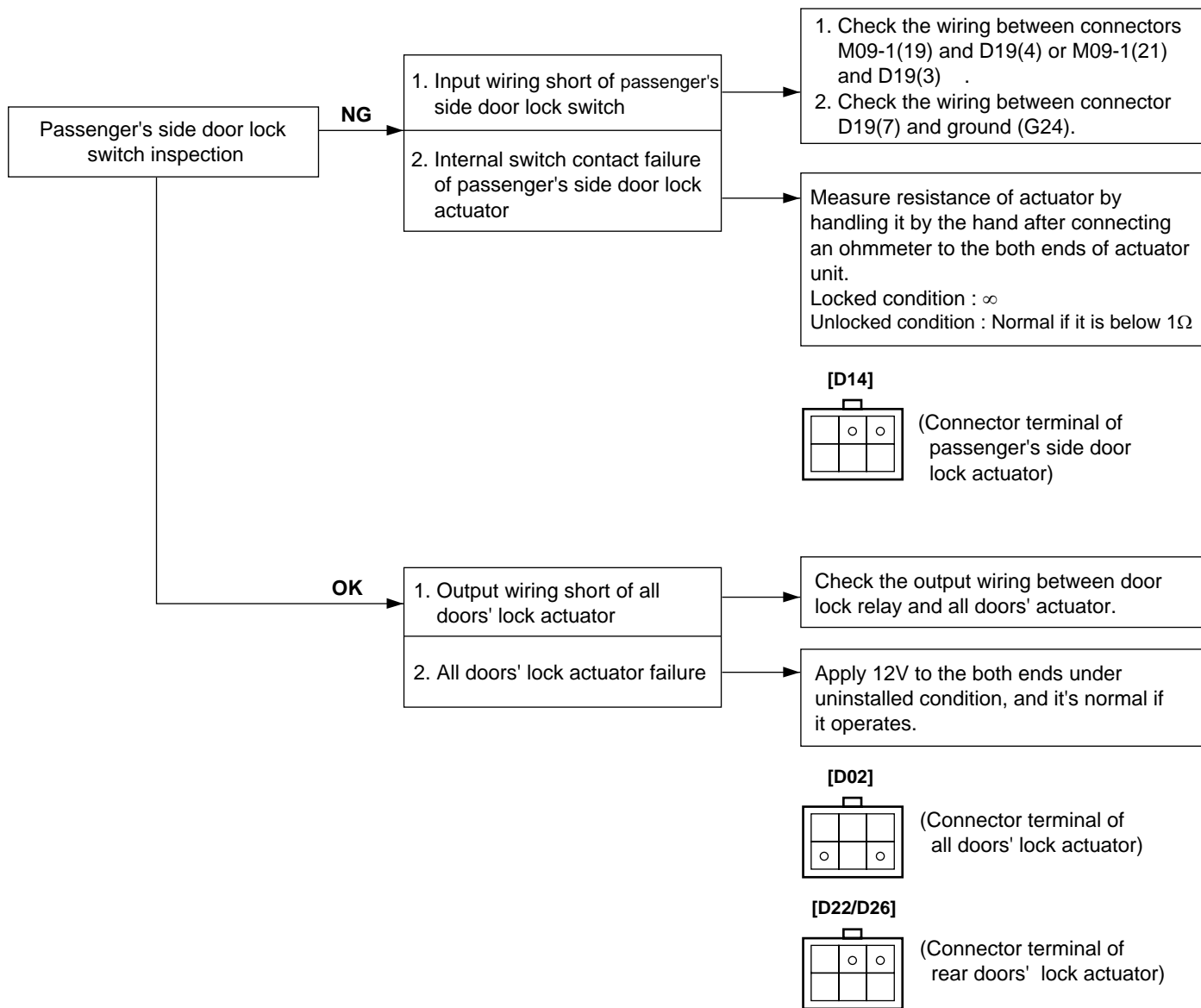

5. Both sides do not lock either.

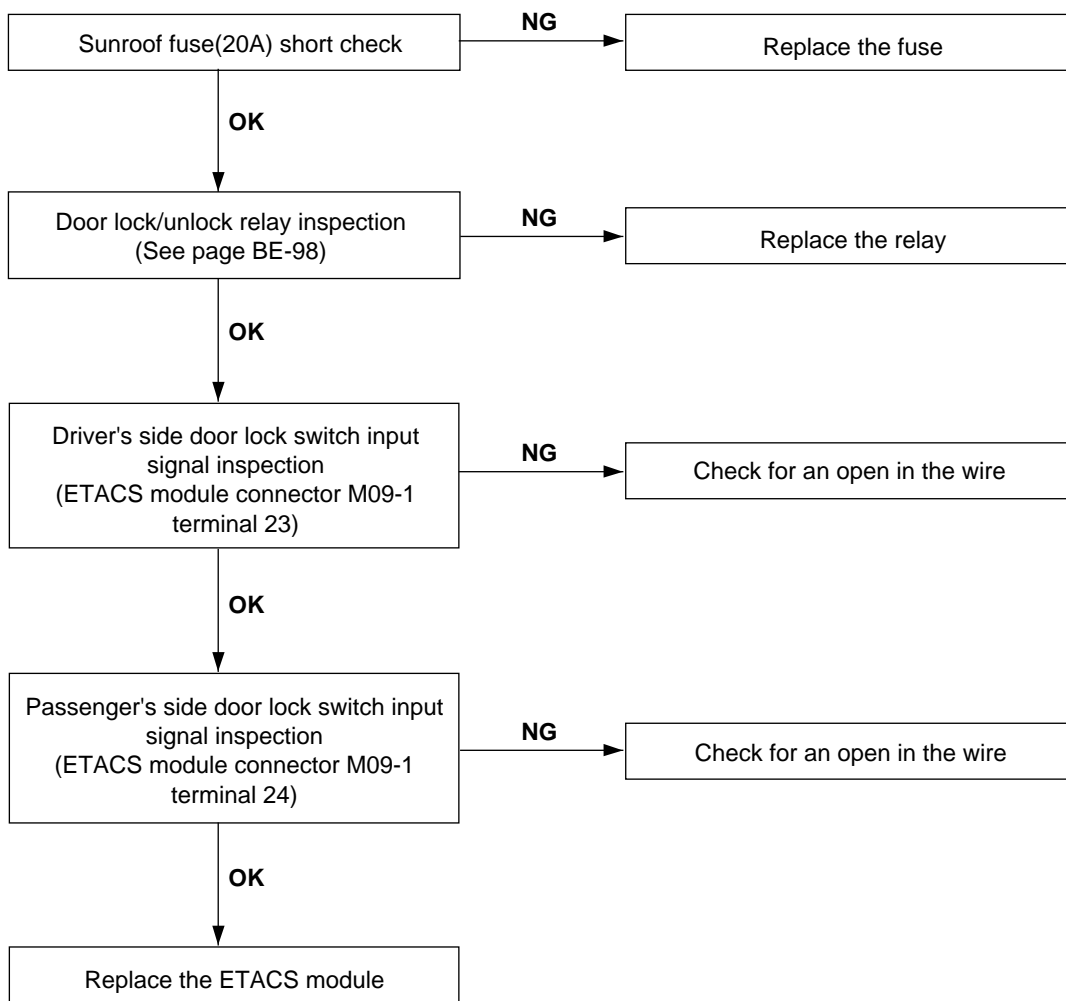

LTIF900H

KEYLESS ENTRY & BURGLAR ALARM SYSTEM

1. Alarm does not work. (Hazard lamp works)

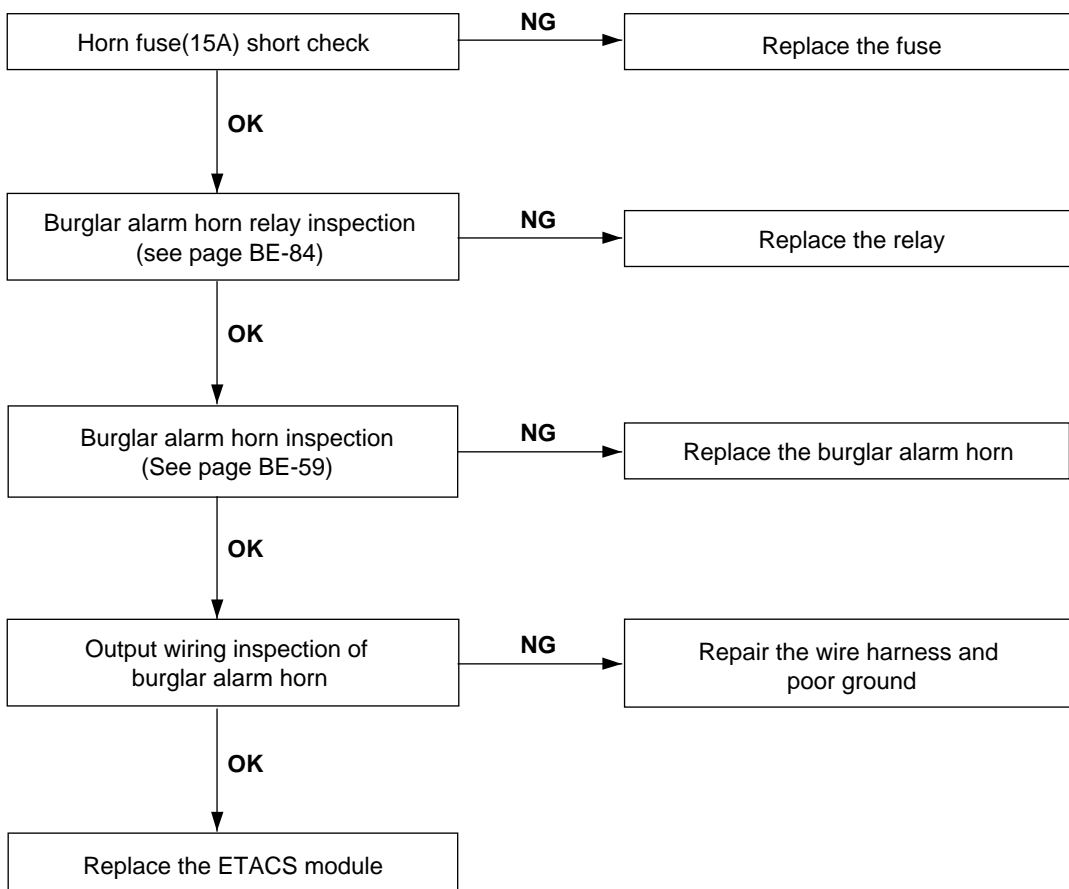

LTIF900I

2. When hood is opened inside the car, burglar horn does not work.

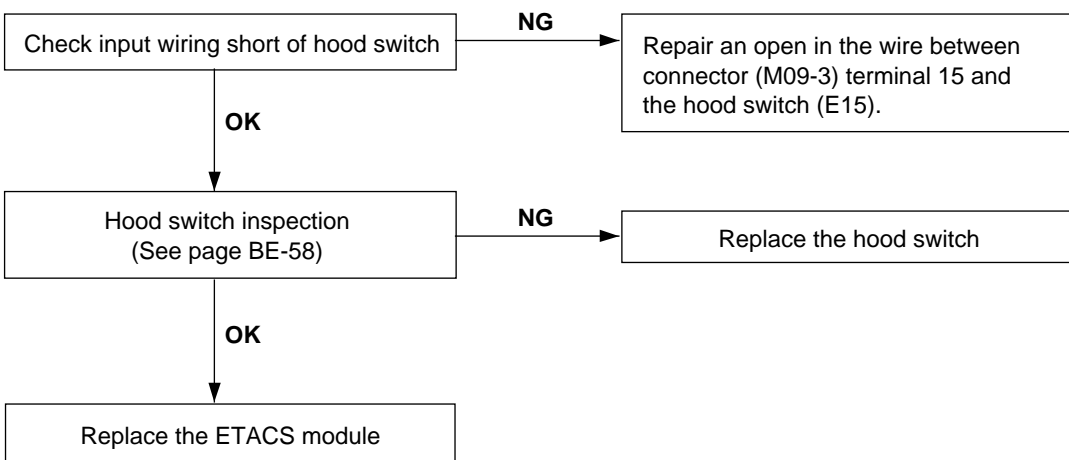

LTIF900J

3. When door is opened inside the car, burglar horn does not work (If tailgate and hood is opened, alarm works)

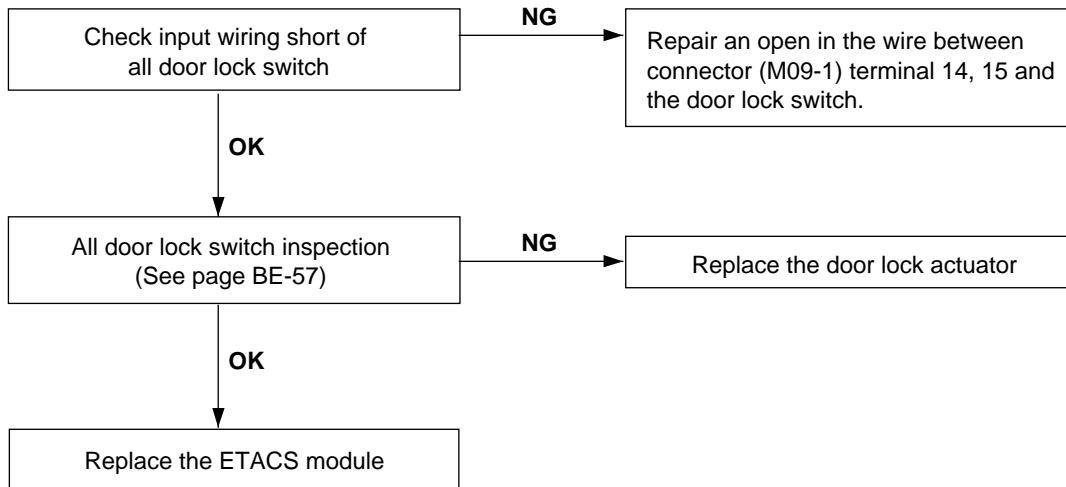

LTIF900K

4. When tailgate is opened inside the car, siren does not work.

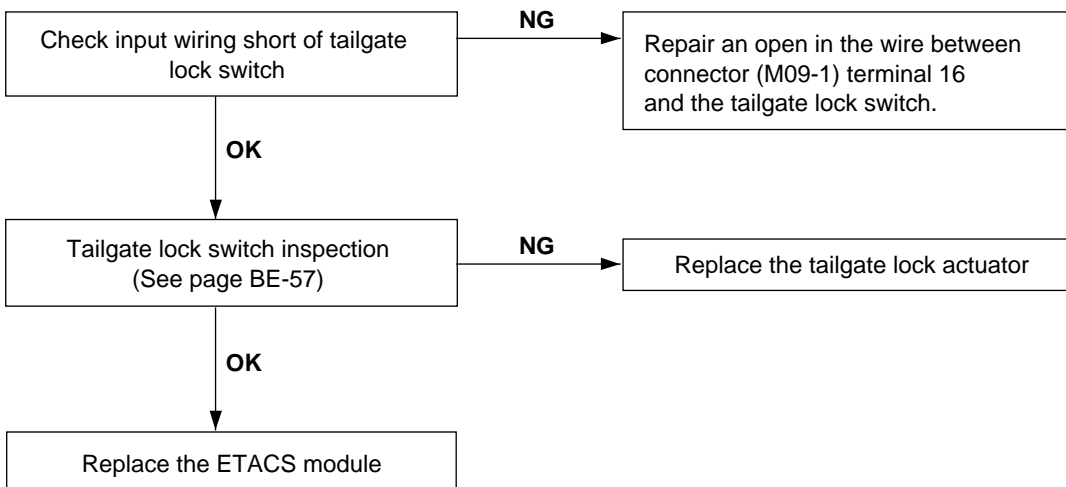

LTIF900L

5. When the vehicle is locked by the transmitter, central door lock function works but hazard lamp doesn't blink.

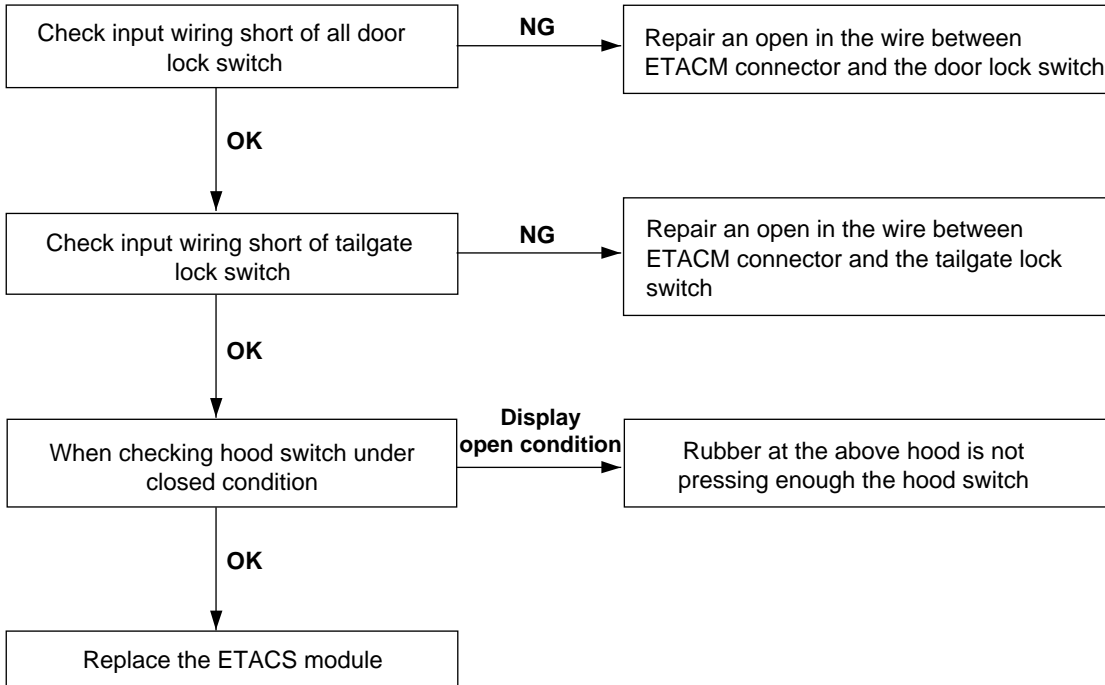

LTIF900M

6. Engine does not start, even when the alarm is disarmed.

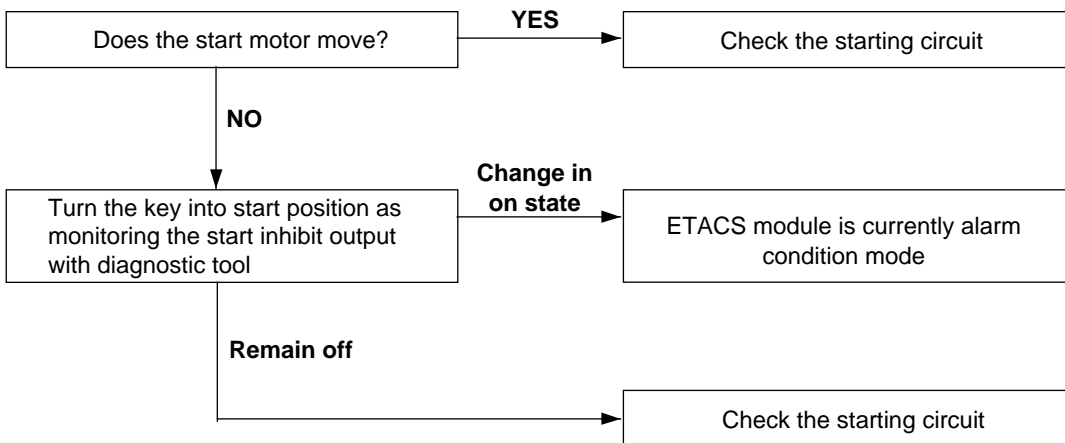

LTIF900N

- 7. Central door lock function works, but keyless entry system does not work.

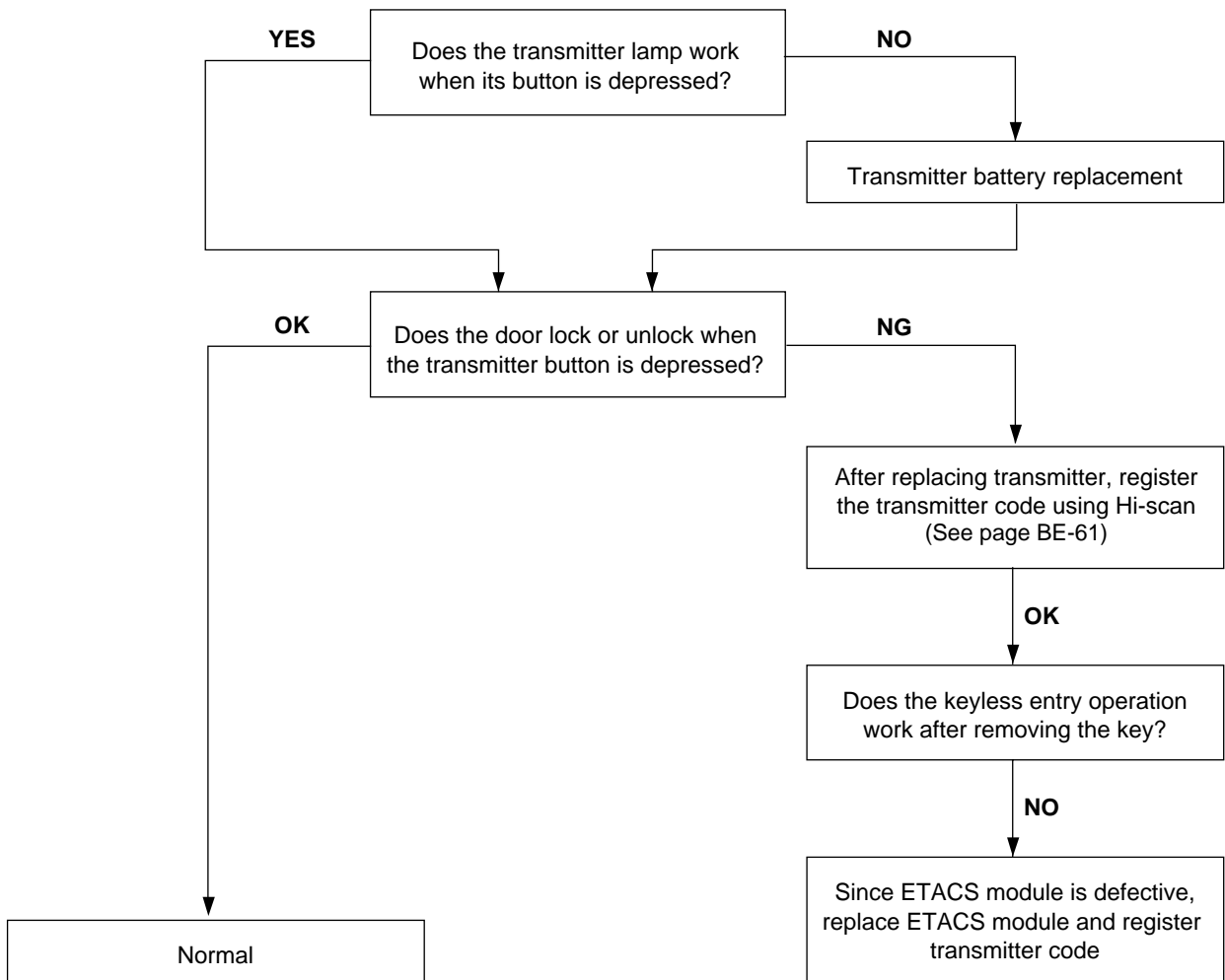

# AUDIO SYSTEM

## COMPONENTS EF59FCAE

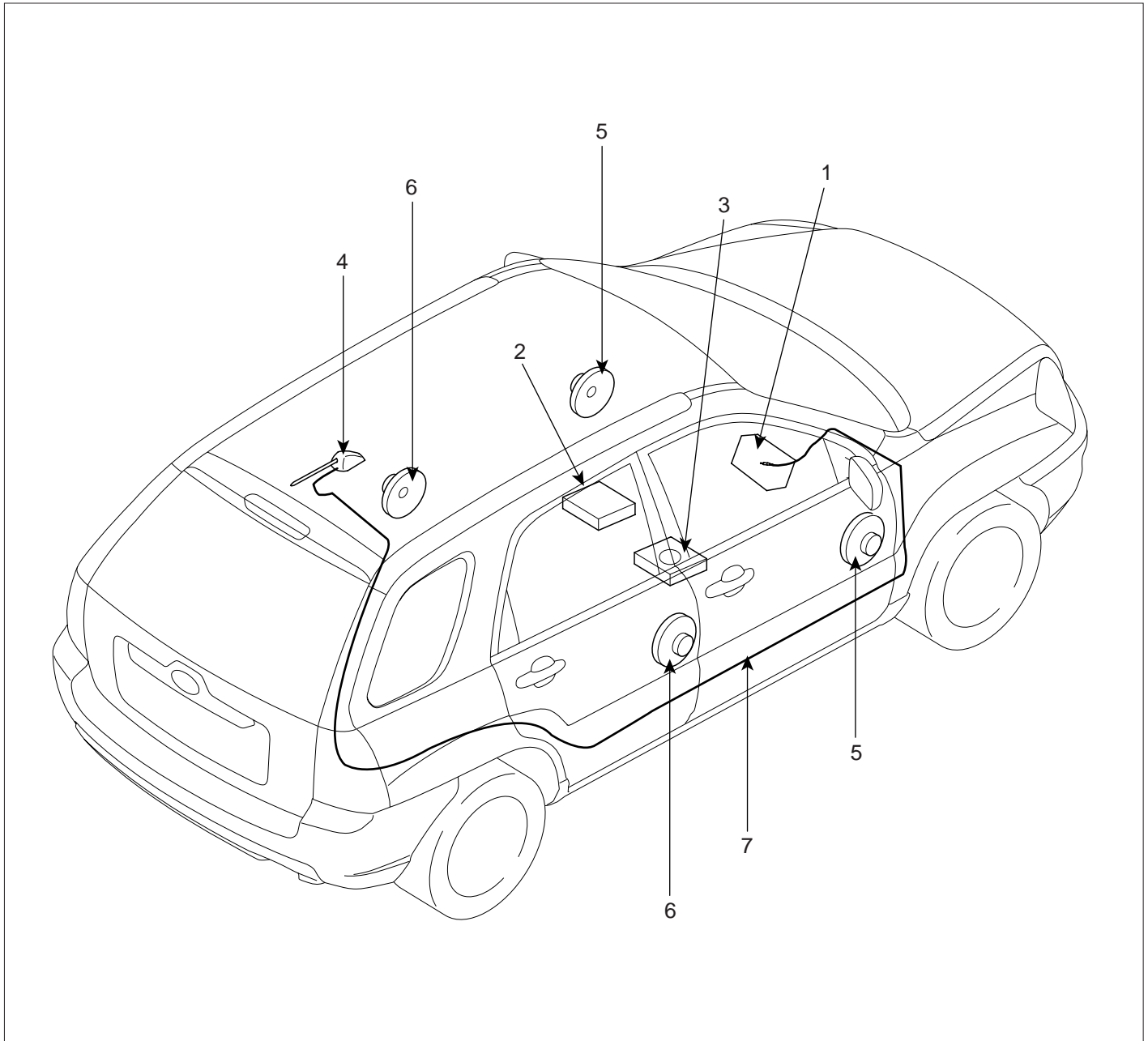

- |                   |                         |
|-------------------|-------------------------|
| 1. Audio unit     | 5. Front door speaker   |
| 2. External amp   | 6. Rear door speaker    |
| 3. Woofer speaker | 7. Antenna feeder cable |
| 4. Roof antenna   |                         |

LTIF020A

**AUDIO SYSTEM**

**SPECIFICATION** EC992E84

Item		Specification			
Model		AM/FM/Cas- sette (M420)	AM/FM/CD (M445)	AM/FM/Cassette /MP3 (M455)	AM/FM/Cassette /6CDC (M465)
Power supply		DC 14.4V			
Rated output		Max 43W x 4			Maw 50W x 4
Speaker impedance		4 x 4			2 x 4
Antenna		80PF 75			
Tuning type		PLL synthesized type			
The others		-			External amp, Sub woofer
Frequency range / Channel space	FM	87.5~108 MHz/ 100KHz (General), 50KHz(Europe)			
	AM	531~1602 KHz/ 9KHz (General)			
	MW	522~1620 KHz/ 9KHz (Europe)			
	LW	153~279 KHz/ 1KHz (Europe)			
	FM	76.0~90.0 MHz/ 100KHz (Japan)			
	AM	522~1629KHz/ 9KHz (Japan)			

**AUDIO UNIT**

**COMPONENT** E62785CB

[AM/FM/Cassette-M420]

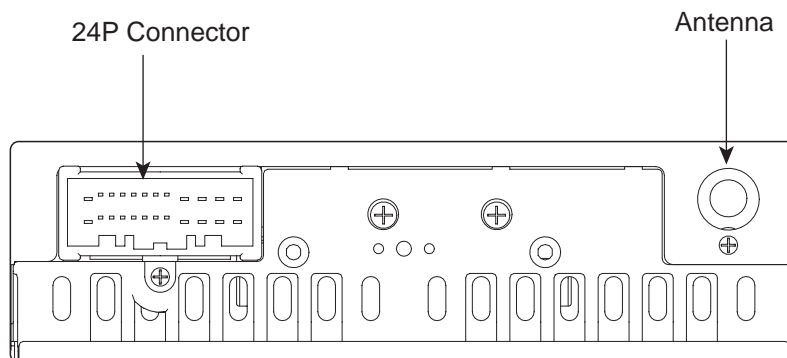
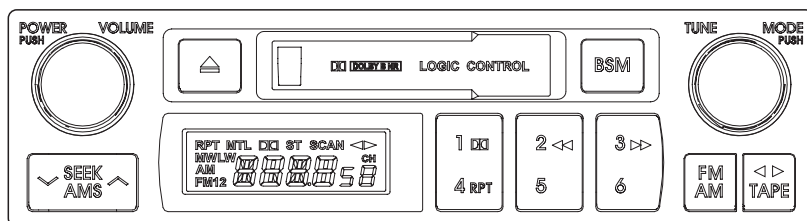

Audio connector	Terminal	Description	Terminal	Description
	1	Ground	13	Remote control ground
	2	Battery	14	Steering remote control
	3	Antenna B+	15	Illumination (-)
	4	ACC	16	Illumination (+)
	5	-	17	Rear left speaker (-)
	6	-	18	Rear left speaker (+)
	7	Tweeter in (R)	19	Rear right speaker (-)
	8	Tweeter in (L)	20	Rear right speaker (+)
	9	Ground	21	Front right speaker (-)
	10	Twiter ground	22	Front right speaker (+)
	11	MUTE	23	Front left speaker (-)
	12	Rear-arm remote control	24	Front left speaker (+)

[AM/FM/CD-M445]

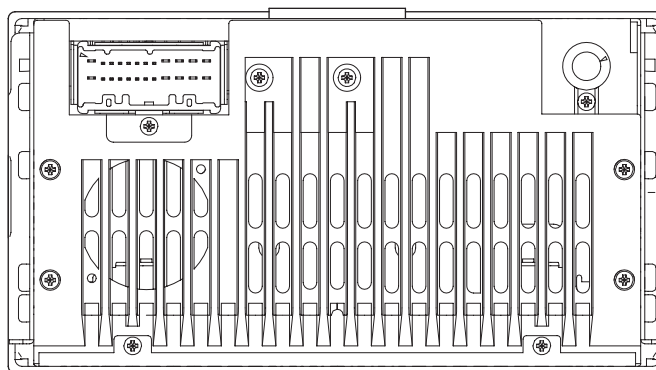
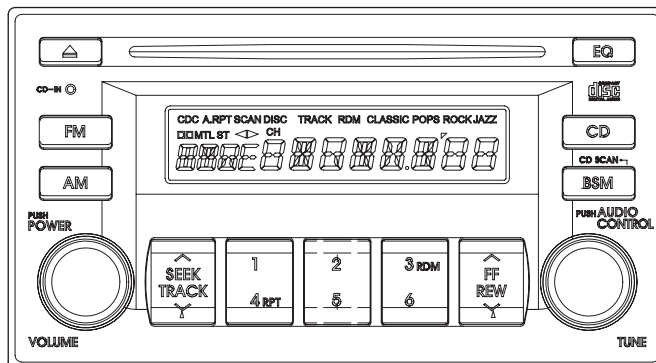

Audio connector	Terminal	Description	Terminal	Description
	1	Ground	13	Remote control ground
	2	Battery	14	Steering remote control
	3	Antenna B+	15	Illumination (-)
	4	ACC	16	Illumination (+)
	5	-	17	Rear left speaker (-)
	6	-	18	Rear left speaker (+)
	7	Tweeter in (R)	19	Rear right speaker (-)
	8	Tweeter in (L)	20	Rear right speaker (+)
	9	Ground	21	Front right speaker (-)
	10	Twiter ground	22	Front right speaker (+)
	11	MUTE	23	Front left speaker (-)
	12	Rear-arm remote control	24	Front left speaker (+)

[ AM/FM/Cassette/MP3-M455 ]

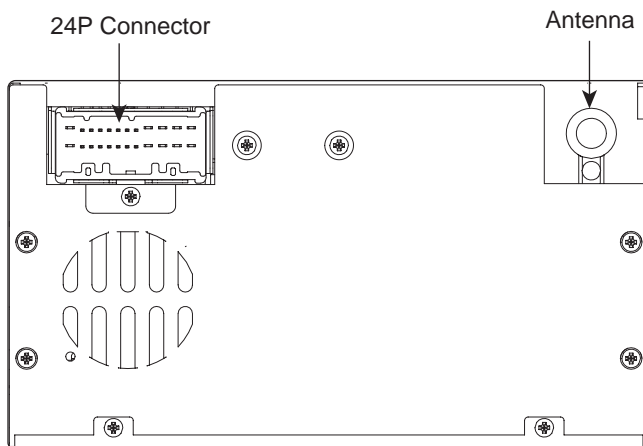
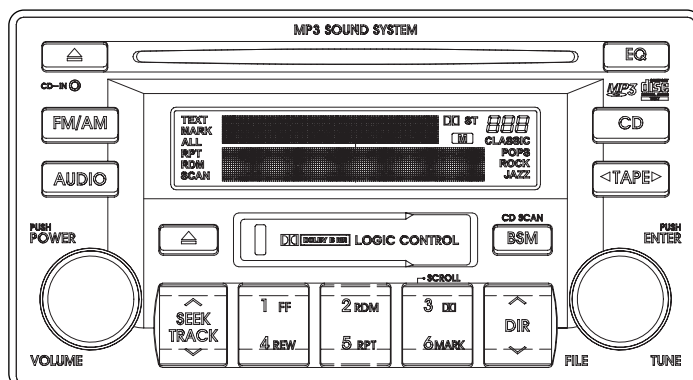

Audio connector	Terminal	Description	Terminal	Description
	1	Ground	13	Remote control ground
	2	Battery	14	Steering remote control
	3	Antenna B+	15	Illumination (-)
	4	ACC	16	Illumination (+)
	5	-	17	Rear left speaker (-)
	6	-	18	Rear left speaker (+)
	7	Tweeter in (R)	19	Rear right speaker (-)
	8	Tweeter in (L)	20	Rear right speaker (+)
	9	Ground	21	Front right speaker (-)
	10	Twiter ground	22	Front right speaker (+)
	11	MUTE	23	Front left speaker (-)
	12	Rear-arm remote control	24	Front left speaker (+)

[ AM/FM/Cassette/6CDC-M465 ]

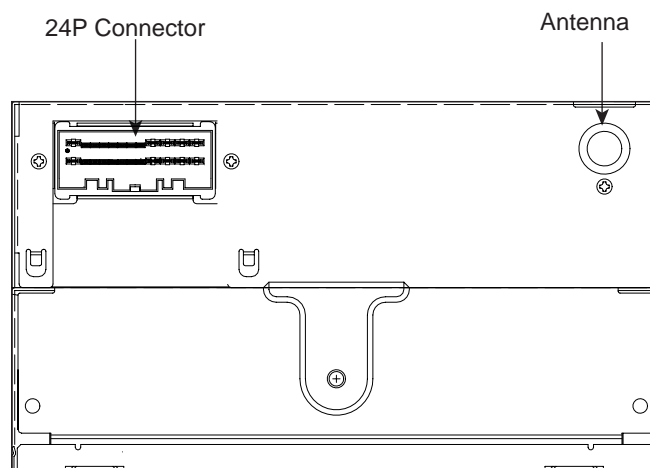
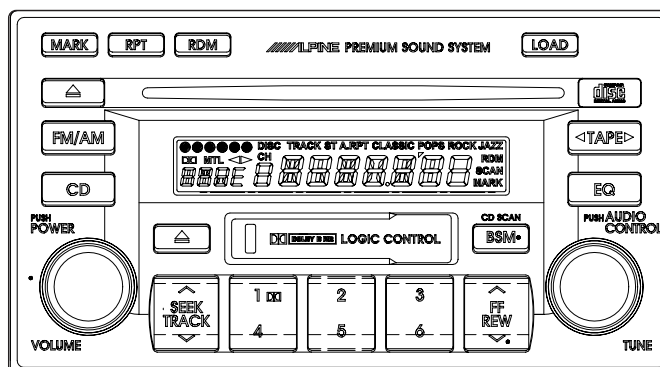

Audio connector	Terminal	Description	Terminal	Description
	1	Ground	13	Remote control ground
	2	Battery	14	Steering remote control
	3	Antenna B+	15	Illumination (-)
	4	ACC	16	Illumination (+)
	5	-	17	Rear left speaker (-)
	6	-	18	Rear left speaker (+)
	7	Tweeter in (R)	19	Rear right speaker (-)
	8	Tweeter in (L)	20	Rear right speaker (+)
	9	Ground	21	Front right speaker (-)
	10	Twiter ground	22	Front right speaker (+)
	11	MUTE	23	Front left speaker (-)
	12	Rear-arm remote control	24	Front left speaker (+)

**REPLACEMENT** EB382B46

1. Disconnect the negative (-) battery terminal.
2. Remove the center facia panel (C) after pulling it by using regular screwdriver(-) at part (A). Take care of fixing clips (B).

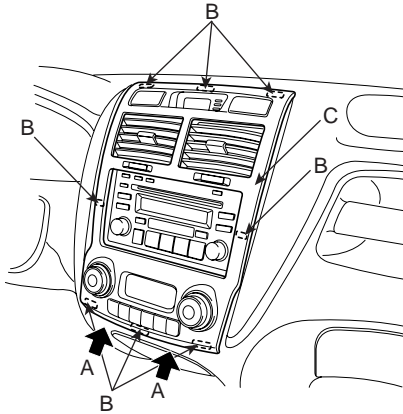

ATIE021A

3. Remove the connectors.
4. Remove the mounting screws then remove the audio unit assembly (A).

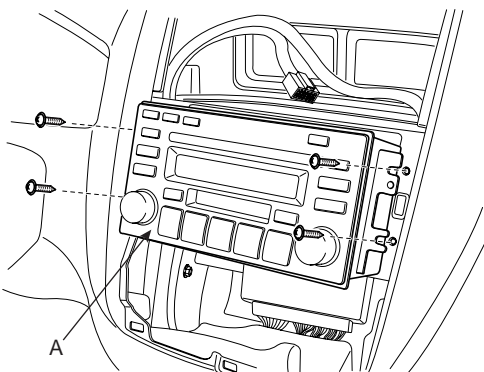

ATIE021E

5. Installation is the reverse of removal.

**INSPECTION** E6E054BB

**TAPE HEAD AND CAPSTAN CLEANING**

1. To obtain optimum performance, clean the head, and capstan as often as necessary, depending on frequency of use and tape cleanliness.
2. To clean the tape head and capstan, use a cotton swab dipped in ordinary rubbing alcohol. Wipe the head and capstan.

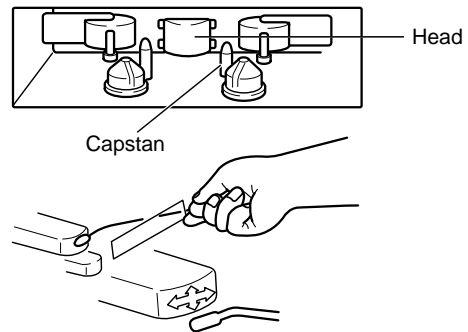

LTAC005A

**SPEAKERS**

**REPLACEMENT** EF7223AB

**FRONT SPEAKER**

1. Remove the front door trim panel (Refer to the BD group - front door).
2. Remove the front speaker (A) after removing 3 screws.

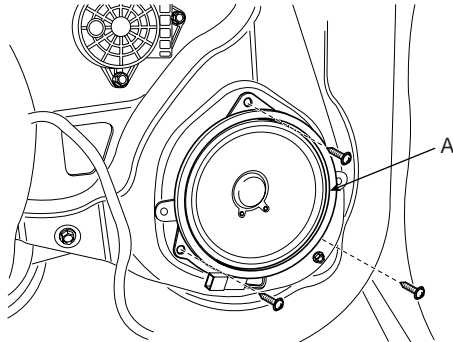

ATIE022B

3. Installation is the reverse of removal.

**REAR SPEAKER**

1. Remove the rear door trim panel (Refer to the BD group - rear door).
2. Remove the rear speaker(A) after removing 3 screws.

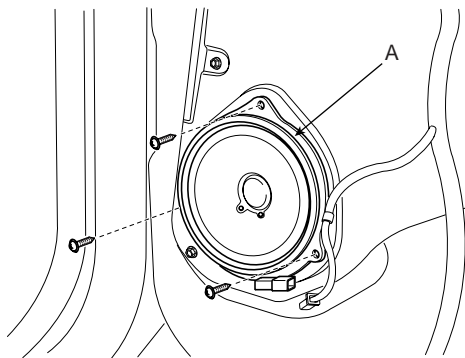

ATIE022C

3. Installation is the reverse of removal.

**TWEETER SPEAKER**

1. Remove the front door trim panel (Refer to the BD group - front door).
2. Remove the tweeter speaker (A) after removing 2 screws.

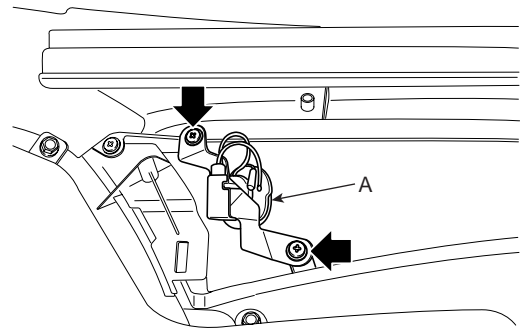

ATIE022D

3. Installation is the reverse of removal.

**WOOFER SPEAKER**

1. Remove the assist side seat.(Refer to the BD group - front seats)
2. Remove the woofer speaker(A) from the assist side floor after removing 2 bolts and 2 nuts.

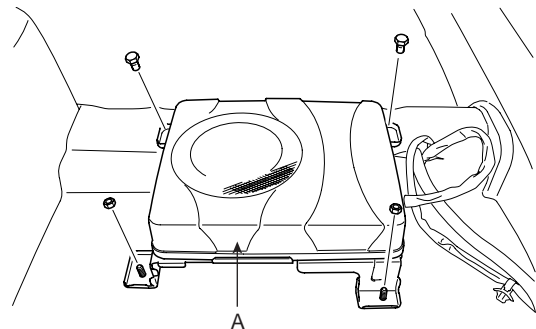

ATIE022E

**EXTERNAL AMP**

1. Remove the driver seat. (Refer to the BD group - front seats)
2. Remove the external amp (A) from the floor beyond the driver seat after removing 3 bolts and 1 nut.

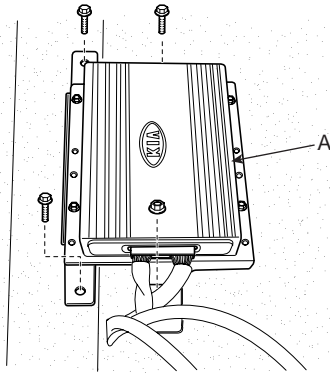

ATIE022F

3. Installation is the reverse of removal.

**INSPECTION** EDEAFE84

1. Check the speaker with an ohmmeter. If an ohmmeter indicates the correct impedance of the speaker when checking between the speaker (+) and speaker (-) of the same channel, the speaker is OK.
2. If a clicking sound is emitted from the speaker when the ohmmeter is connected to the speaker terminals, the speaker is OK.

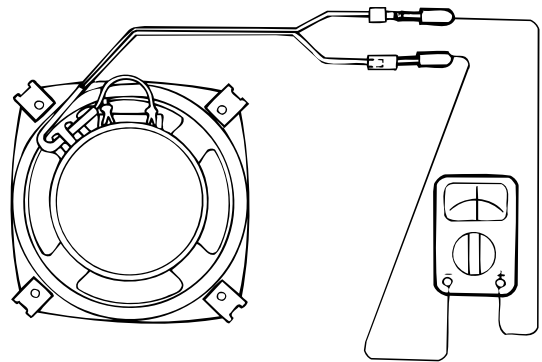

KTMB060A

## ANTENNA

### REPLACEMENT EA883095

1. Remove the rear roof trim (Refer to BD group-roof trim).
2. Disconnect the 1P connector (A) and antenna jack (B) from the roof antenna.
3. Remove the roof antenna after removing a nut.

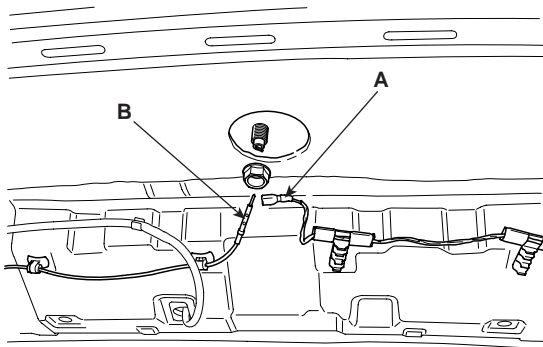

ATIE023A

4. Installation is the reverse of removal.

## MULTI FUNCTION SWITCH

### SPECIFICATIONS E7A7EEF9

Items	Specifications
Rated voltage	DC 12 V
Operating temperature range	-30°C ~ +80°C (-22 ~ +176°F)
Rated load Dimmer & passing switch  Lighting switch Turn signal & lane change switch Front fog lamp switch Wiper & mist switch  Washer switch Variable intermittent volume switch Rear wiper & washer switch	High : 15A (Relay load) Low : 10A (Relay load) Passing : 15A (Relay load) Lighting : 1A (Relay load) 6.6±0.5A (Lamp load) 1A (Relay load) Low, High : 4A (Motor load) Intermittent : 0.22±0.05A (Relay load) Lock : Max. 23A (Motor load) Mist : 4A (Motor load) 4A (Motor load) Max. 25mA Rear wiper : 200mA (Relay load) Rear washer : 4A (Motor load)

**MULTI FUNCTION SWITCH**

**COMPONENTS** E657EF09

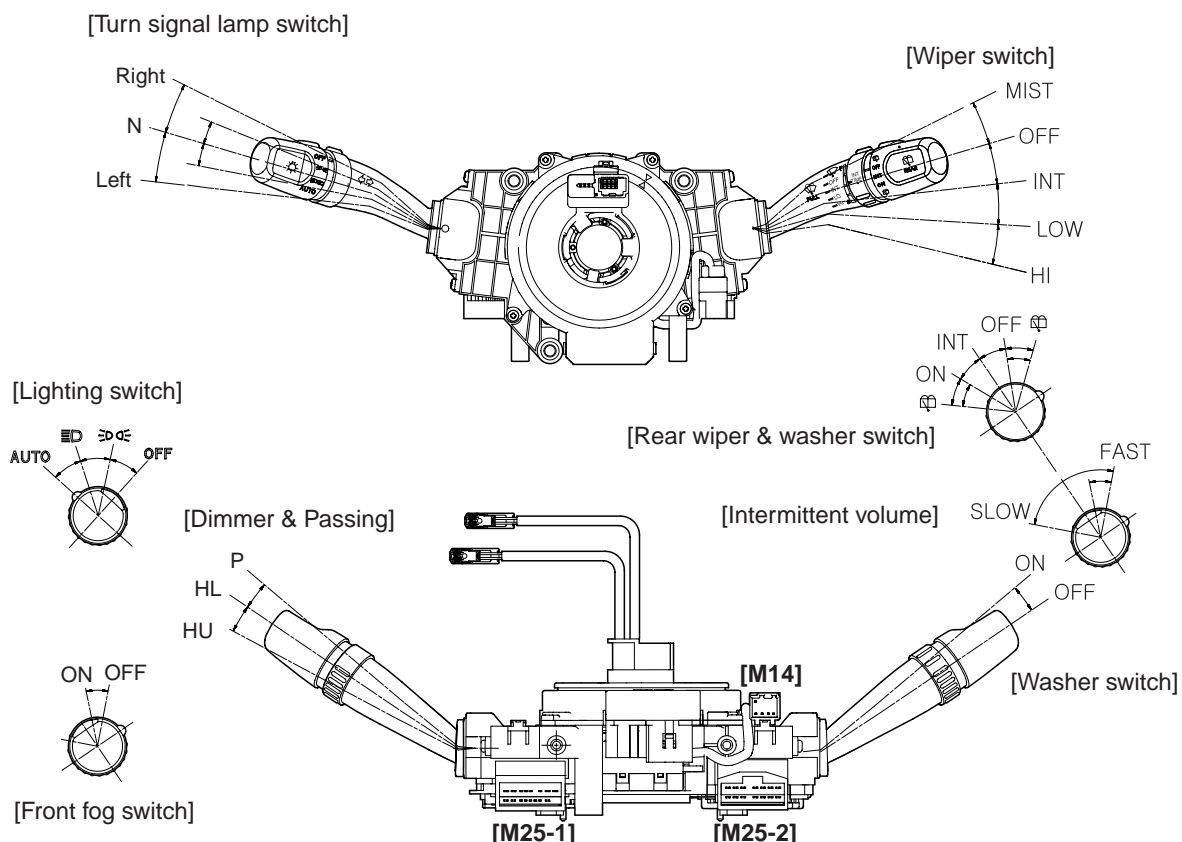

[M25-1]

1	2	3	4	5	6	7	8	9
10	11	12	13	14	15	16	17	18

[M25-2]

1	2	3	4	5	6	7
8	9	10	11	12	13	14

**Circuit connection**

Connector No.	Terminal No.	Description	Connector No.	Terminal No.	Description
M25-1	1	Head lamp passing	M25-2	1	Wiper high speed
	2	Head lamp high beam power		2	Wiper low speed
	7	Turn signal lamp (RH)		3	Wiper parking
	8	Flasher unit power		4	Mist switch
	9	Turn signal lamp (LH)		5	Wiper & washer power
	10	Head lamp low beam power		6	Intermittent wiper
	11	Dimmer & passing ground		7	Front washer switch
	12	Front fog switch		8	-
	13	Front fog switch ground		9	Rear wiper & washer ground
	14	Tail lamp switch		10	Intermittent rear wiper
	15	Head lamp switch		11	Rear wiper
	16	Auto light switch		12	Rear washer
	17	Lighting switch ground		13	Intermittent wiper volume
	18	-		14	Intermittent wiper ground

**REPLACEMENT**

EBCEC5F6

1. Remove the steering column upper and lower shrouds (A) after removing 3 screws.

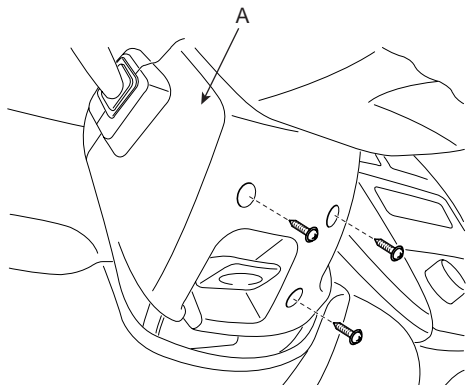

ATIE031B

2. Remove the light switch (B) after loosening its 2 screws and connector (A).

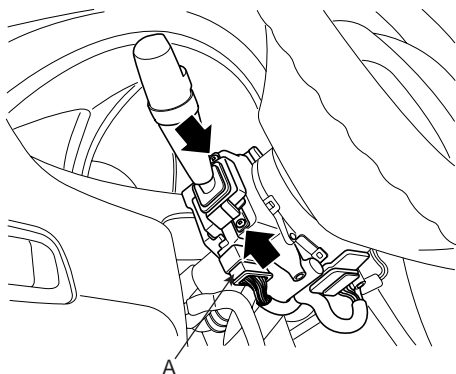

LTIF031C

3. Remove the wiper switch (B) after loosening its 2 screws and connector (A).

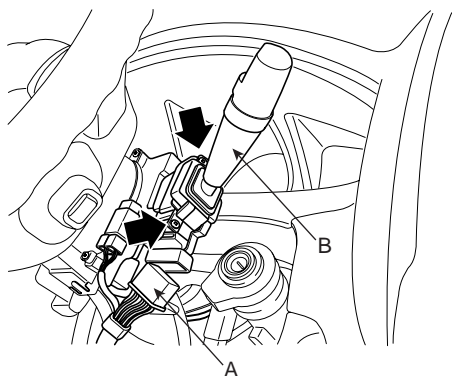

LTIF031D

4. Installation is the reverse of removal.

**INSPECTION**

EA21CDEF

**LIGHTING SWITCH INSPECTION**

With the multi function switch in each position, make sure that continuity exists between the terminals below. If continuity is not as specified, replace the multi-function switch.

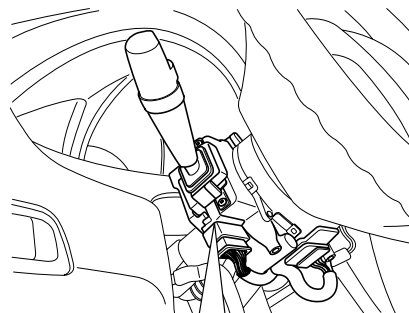

1	2	3	4	5	6	7	8	9
10	11	12	13	14	15	16	17	18

ATIE031E

**LIGHTING SWITCH (AUTO LIGHT)**

Terminal Position	14	15	16	17
OFF				
I	○	—	—	○
II	○	—	○	○
AUTO			○	○

LTGE031E

**LIGHTING SWITCH**

Terminal Position	14	15	16	17
OFF				
I	○	—		○
II	○	—	○	○

LTGE031B

**MULTI FUNCTION SWITCH**

**DIMMER AND PASSING SWITCH**

Terminal Position	1	2	10	11
HU		○ ————— ○		
HL			○ ————— ○	
P	○ ————— ○			○ ————— ○

HU : Head lamp high beam  
 HL : Head lamp low beam  
 P : Head lamp passing switch

LTGE031F

**TURN SIGNAL SWITCH**

Terminal		7	8	9
Hazard switch	Trun signal switch			
	L		○ ————— ○	
	N			
OFF	R	○ ————— ○		

LTGE031G

**FRONT FOG LAMP SWITCH**

Terminal Position	12	13
OFF		
ON	○ ————— ○	

LTGE031H

**WIPER AND WASHER SWITCH INSPECTION**

With the multi function switch in each position, make sure that continuity exists between the terminals below. If continuity is not as specified, replace the multi-function switch.

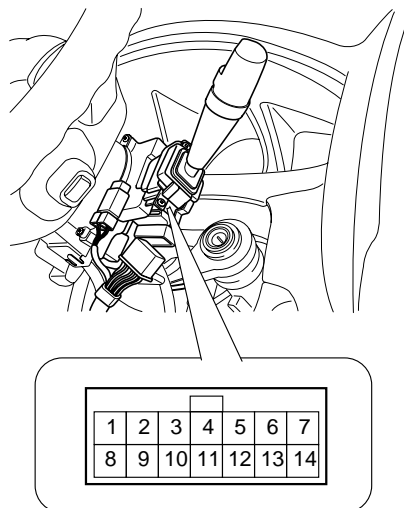

ATIE031G

**WIPER SWITCH**

Terminal Position	1	2	3	4	5	6	13	14
MIST				○ ————— ○				
OFF		○ ————— ○						
INT		○ ————— ○			○ ————— ○		○ ————— ○	○ ————— ○
LOW		○ ————— ○		○ ————— ○				
HI	○ ————— ○			○ ————— ○				

LTGE031I

WASHER SWITCH

Terminal Position	5	7
OFF		
ON		

LTGE031J

REAR WIPER & WASHER SWITCH

Terminal Position	9	10	11	12
Rear washer				
OFF				
INT				
ON				
Rear washer				

LTIF031K

# HORNS

COMPONENTS E9B4523A

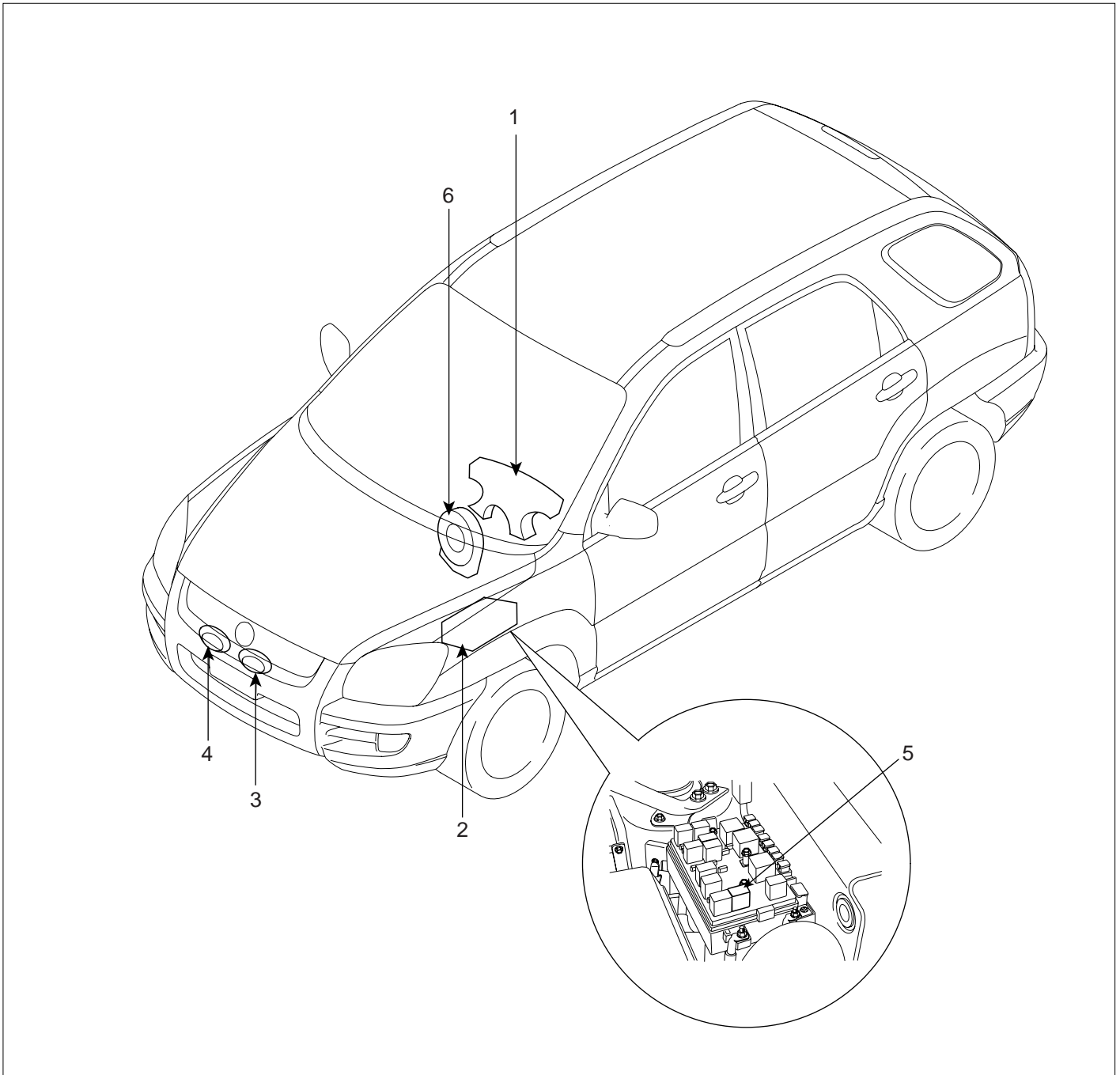

- 1. Horn switch
- 2. Relay box (Engine room compartment)
- 3. Horn (High pitch)

- 4. Horn (Low pitch)
- 5. Horn relay
- 6. Clock spring

LTIF051A

**REPLACEMENT** E40AAA7C

1. Remove the front bumper. (Refer to the BD group - front bumper).
2. Remove the bolt (C) and disconnect the horn connector, then remove the high pitch horn (A) and low pitch horn (B).

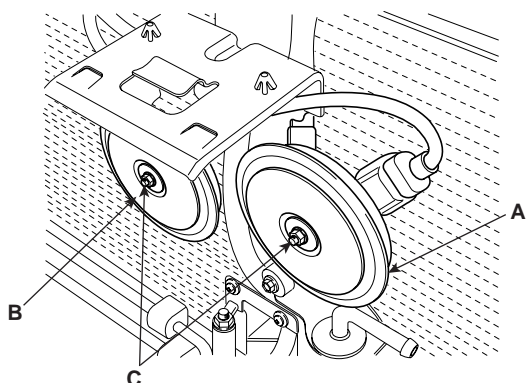

ATIE051B

3. Installation is the reverse of removal.

**INSPECTION** EC1F39F9

Test the horn by connecting battery voltage to the 1 terminal and ground the 2 terminal. The horn should make a sound. If the horn fails to make a sound, replace it.

**ADJUSTMENT**

Operate the horn, and adjust the tone to a suitable level by turning the adjusting screw.

**NOTE**

After adjustment, apply a small amount of paint around the screw head to keep it from loosening.

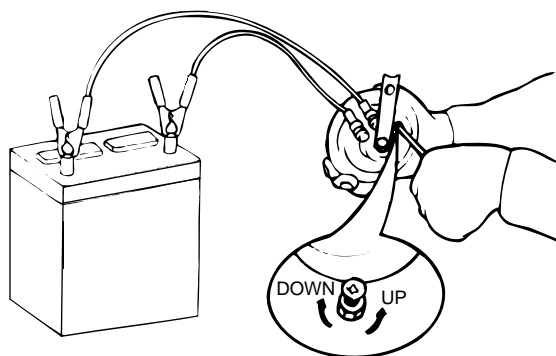

ETDA050A

**HORN RELAY INSPECTION**

1. Remove the horn relay (A) from the engine room relay box.
2. There should be continuity between the No.87 and No.30 terminals when power and ground are connected to the No.86 and No.85 terminals.
3. There should be no continuity between the No.87 and No.30 terminals when power is disconnected.

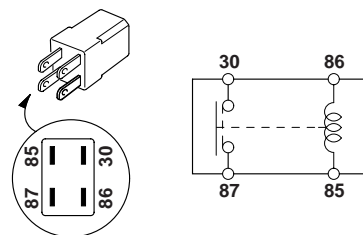
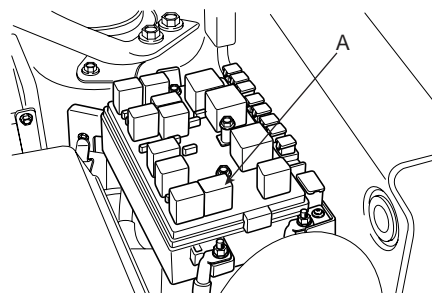

ATIE051C

Terminal	30	87	85	86
Power				
Disconnected			○ — ○	
Connected	○ — ○		⊖ — ⊕	

LTGE221B

# KEYLESS ENTRY AND BURGLAR ALARM

## COMPONENTS E01A82EF

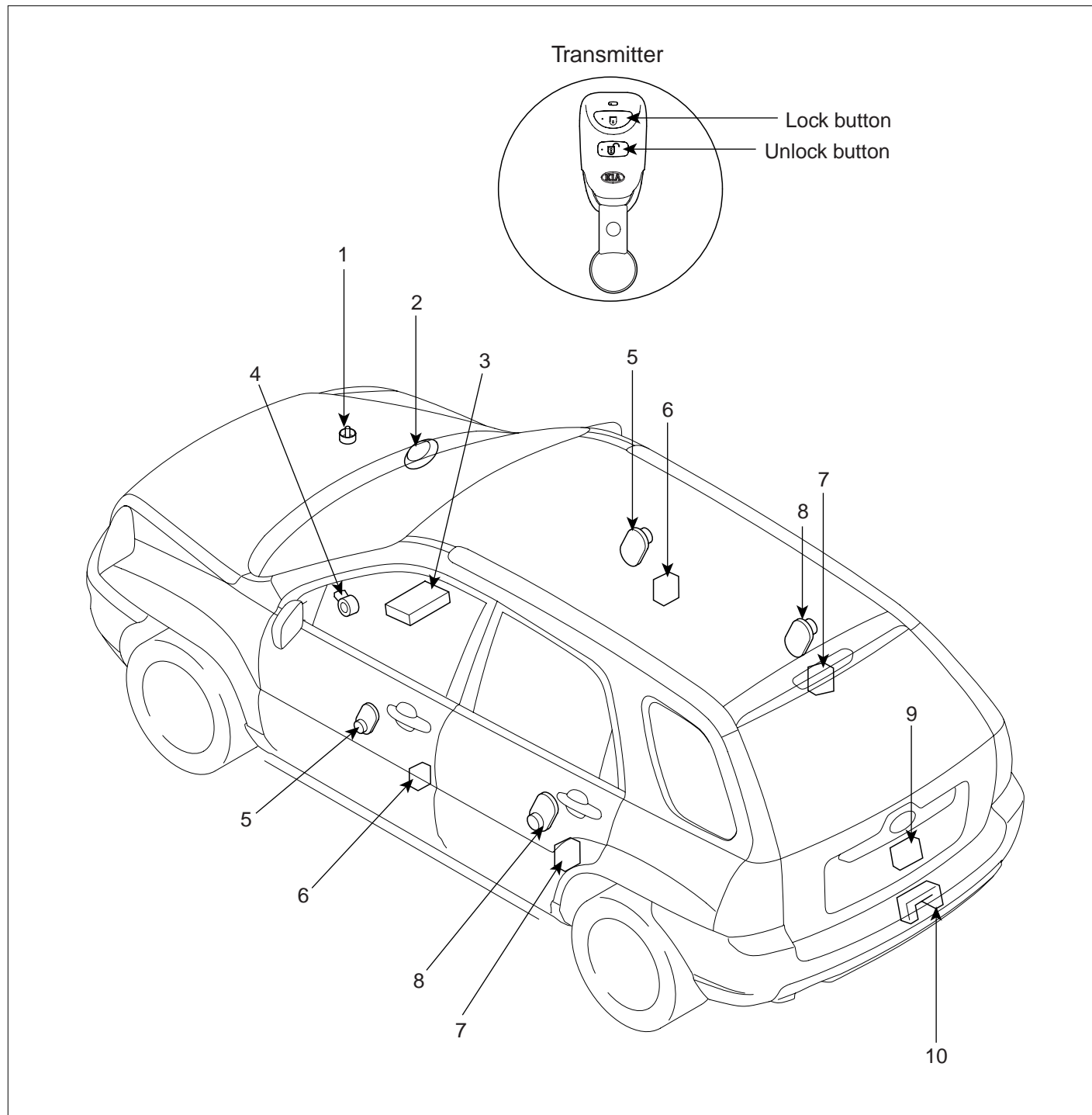

- 1. Hood switch
- 2. Burglar horn
- 3. ETACS module
- 4. Key warning switch
- 5. Front door switch

- 6. Front door lock actuator & switch
- 7. Rear door lock actuator & switch
- 8. Rear door switch
- 9. Tailgate lock actuator & switch
- 10. Tailgate switch

**DESCRIPTION** E7B5B27B

**BURGLAR ALARM SYSTEM**

The burglar alarm system is armed automatically after the doors, hood, and tailgate are closed and locked.

The system is set off when any of these things occur :

- A door is forced open.
- A door is unlocked without using the transmitter.
- The tailgate is opened without using the key.
- The hood is opened.
- The engine starter circuit and battery circuit are bypassed by breaking the ignition switch.

When the system is set off, the alarm (horn) sounds and the hazard lamp flash for about two minutes or until the system is disarmed by unlocking the transmitter.

For the system to arm, the ignition switch must be off and the key removed. Then, the ETACS module must receive signals that the doors, hood, and tailgate are closed and locked. When everything is closed and locked, none of the control unit inputs are grounded.

The door switches, hood switch and tailgate switch are all close then immediately after locking the doors with the remote transmitter the system arms.

If anything is opened or improperly unlocked after the system is armed, the ETACS module gets a ground signal from that switch, and the system is set off.

If one of the switches is misadjusted or there is a short in the system, the system will not arm. As long as the ETACS module continues to get a ground signal, it thinks the vehicle is not closed and locked and will not arm.

The receiver is integrated in the ETACS.

**KEYLESS ENTRY SYSTEM**

The burglar alarm system is integrated with the keyless entry system. The keyless entry system allows you to lock and unlock the vehicle with the remote transmitter. When you push the LOCK button, all doors lock. When you push the UNLOCK button all doors unlock.

The room lamp, if its switch is in the center position, will come on when you press the UNLOCK button. If you do not open a door, the light will go off in about 30 seconds, the doors will automatically relock, and the burglar alarm system will rearm. If you relock the doors with the remote transmitter within 30 seconds, the light will go off immediately.

You cannot lock or unlock the doors with the remote transmitter if the key is in the ignition switch.

The system will signal you when the doors lock and unlock by flashing the hazard lamp once when they lock, and twice when they unlock.

**PANIC MODE**

The panic mode rigs the ETACS to sound the alarm with the remote transmitter in order to attract attention. When the PANIC button is pressed and held for 0.5 seconds, the alarm will sound and exterior lights will flash for about 30 seconds.

The panic mode can be canceled at any time by pressing any button on the remote transmitter or by turning the ignition switch ON. The panic mode will not function if the ignition switch is ON.

**FUNCTION** EFE10B4B

**ANTI-THEFT FUNCTION**

**1. ARM Function**

- 1) When using LOCK on the RKE (Remote Keyless Entry) the doors will lock, the hazard lamp will blink once within .06 seconds (MAX 0.06seconds) and the Anti-Theft System will ARM, if the following conditions have been met.
  - The ignition key is removed from the ignition switch.
  - All entry points are closed (doors, tailgate and hood)
- 2) If either the door or trunk or hood is open when activating LOCK using the RKE, the doors will lock, however the hazard lamp will not flash and the Anti-Theft System will not arm.
- 3) In Step 2) if the opened entry points are subsequently closed, the door will lock, the hazard lamp will blink once and the Anti-Theft System will ARM.
- 4) If LOCK is activated on the RKE while the Anti-Theft system is already in the ARM mode, the hazard lamp will blink once. (If, however, any of the vehicle entry points is unlocked the Anti-Theft System will lock the door, the hazard lamp will blink once, and the system will re-ARM itself.
- 5) The ARM mode of the Anti-Theft System can only be set using the LOCK feature of the RKE. The door key will not arm the Anti-theft System.
- 6) Once the ignition key is IN (inserted into the ignition switch) and the ignition is turned to the ON position the Anti-Theft system will immediately DISARM.
- 7) If the UNLOCK signal is sent by the RKE, and either the ignition key is not inserted or entry (door, trunk, hood) to the vehicle is not made within 30 seconds, the LOCK mode will be automatically reset, the hazard lamps will blink, and the Anti-Theft System will rearm. (Key IN = Key Insertion)  
(Provided that there is no automatic lock function at a period of 30 seconds, when the UNLOCK is done by the RKE with an entry being open).
- 8) In steps 7), when UNLOCK is activated within the initial 30 seconds, another period of 30 seconds occurs.
- 9) Automatic lock will not function if an entry point is opened within 30 seconds of activating UNLOCK.

- 10) Once the 30 seconds have passed, after the initial UNLOCK, the Anti-Theft System will lock the doors, blink the hazard lamps and then ARM.

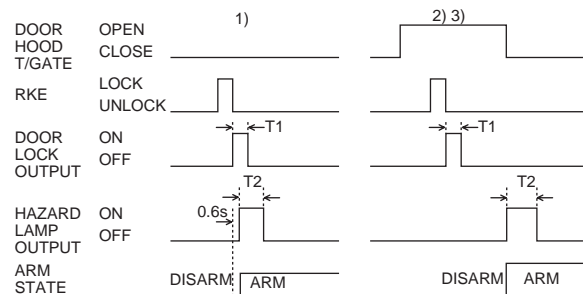

LTIF1210

T1 : 0.5 sec,  
T2 : 1.0 ± 0.1 sec.

**2. DISARM Function**

- 1) When UNLOCK is pressed on the RKE (Remote Keyless Entry control) the Anti-Theft System will DISARM, the hazard lamps blink 2 times and the doors unlock. (Whether entry points are open or closed is irrelevant)
- 2) In DISARM mode, the ALARM and start inhibitor do not function.
- 3) When repeating UNLOCK on the RKE, the hazard lamps blink 2 times and the doors unlock.

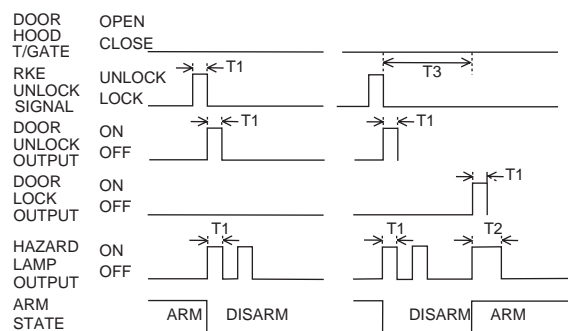

LTIF121P

T1 : 0.5 sec,  
T2 : 1.0 ± 0.1 sec,  
T3 : 30 sec.

3. ALARM Function

1) GENERAL AREA

- a. When a point of entry is opened while the Anti-Theft System is in the ARM mode, the hazard lamp and horn alarm will activate (ON/OFF 3 times each) for a period of 27 seconds.
- b. Output intervals for the horn alarm and hazard lamps are identical.
- c. The alarm sequence, when activated will continue for the duration of the alarm period even when the entry point is closed. (The alarm will reactivate if entry port is reopened after the initial alarm sequence completes.)

2) EUROPE AREA

- a. When a point of entry is opened while the Anti-Theft System is in the ARM mode, the hazard lamp and horn alarm will activate (ON/OFF 1 time each) for a period of 27 seconds.
- b. Output intervals for the horn alarm and hazard lamps are identical.
- c. The alarm sequence, when activated will continue for the duration of the alarm period even when the entry point is closed. (The alarm will reactivate if entry port is reopened after the initial alarm sequence completes.)

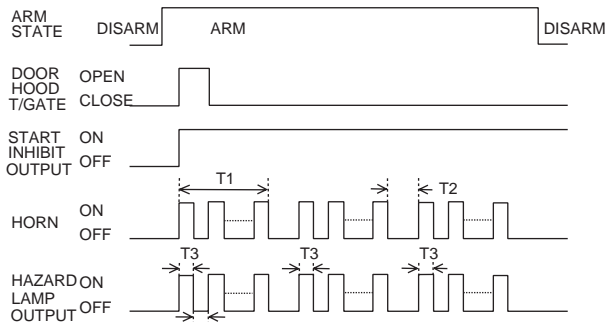

T1 : 27 ± 2 sec,  
 T2 : 10 ± 1 sec,  
 T3 : 0.5 ± 0.1 sec.

LTIF121C

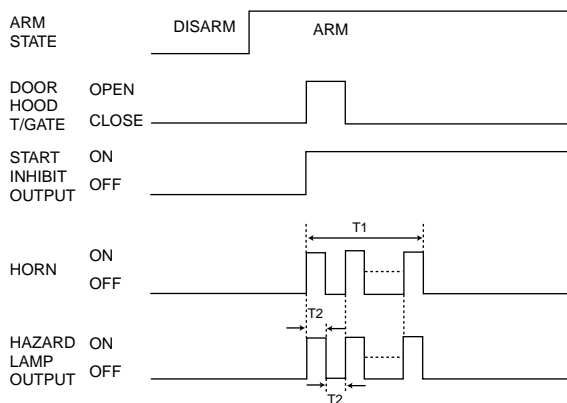

T1 : 27 ± 2 sec,  
 T2 : 0.5 ± 0.1 sec.

LTGE121R

4. New alarm condition during active alarm activation.

- 1) If a new alarm condition occurs during the initial alarm sequence, the start inhibitor will remain on and only the horn alarm will continue. (The alarm will continue even if the point of entry is closed.)

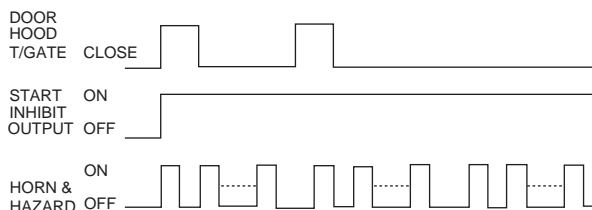

LTIF121D

5. Activating RKE UNLOCK during an alarm sequence.

- 1) If the RKE UNLOCK is activated during an alarm sequence, UNLOCK will output and hazard lamps blink 2 times the Anti-Theft system will DISARM.  
The horn, hazard lamps and start inhibitor will be off.

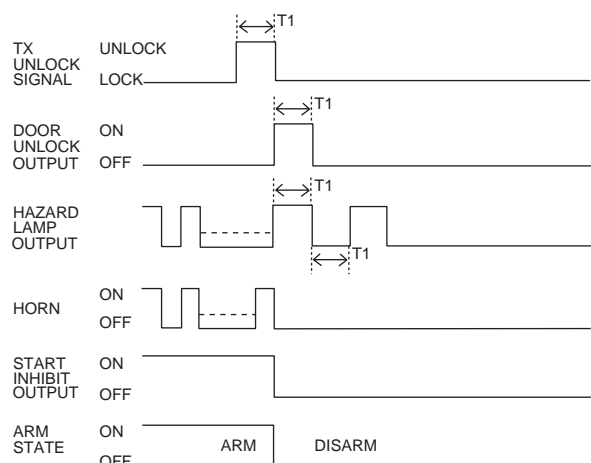

LTIF121F

T1 : 0.5 sec.

6. RKE controlled LOCK during an alarm sequence

- 1) When a RKE (Remote Keyless Entry) controlled LOCK occurs during an alarm sequence, but after the door, that had been broken-in, has been closed the following occurs:
  - All entry points are checked and then LOCK occurs.
  - Horn alarm and start inhibitor are set to off.
  - Hazard lamp blinks once.
  - Anti-Theft system is set to ARM.
- 2) When a RKE controlled LOCK occurs during an alarm sequence, but the broken-in door remains opened the following occurs:
  - All entry points are checked and then LOCK occurs.
  - Horn alarm and start inhibitor are set to off.  
(If the door is then closed the hazard lamp will blink once and the Anti-Theft system will ARM)

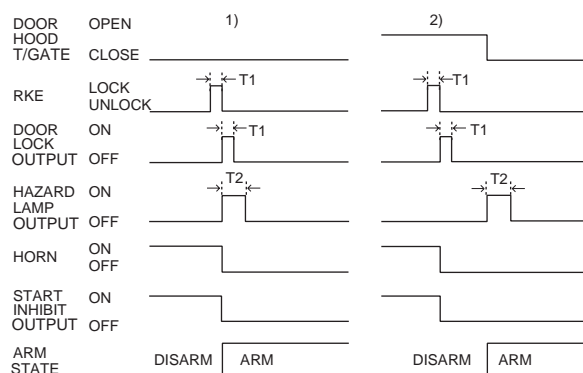

LTIF121G

T1 : 0.5 sec,  
T2 : 1.0 ± 0.1 sec.

7. New condition occurs after an alarm.

1) GENERAL AREA

- a. When all the doors are opened after the doors were closed and locked after an alarm is ON 3 times, the horn alarm, hazard lamps and start inhibitor will engage again.

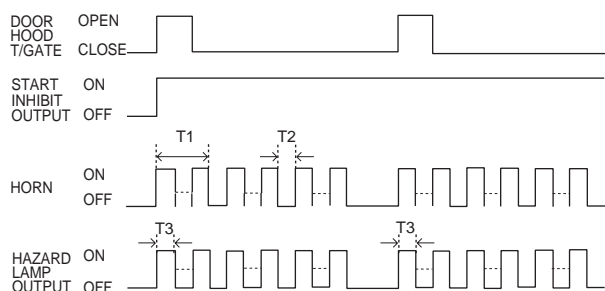

LTIF121H

T1 :  $27 \pm 2$  sec,  
 T2 :  $10 \pm 1$  sec,  
 T3 :  $0.5 \pm 0.1$  sec.

- b. If an alarm occurs due to an open point of entry, and then an unaffected door is opened, the start inhibitor will remain ON, but the horn alarm will not restart.

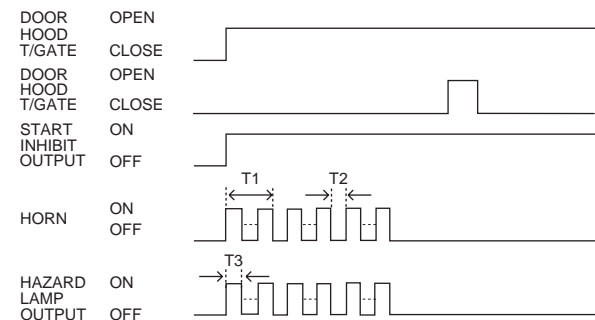

LTIF121I

T1 :  $27 \pm 2$  sec,  
 T2 :  $10 \pm 1$  sec,  
 T3 :  $0.5 \pm 0.1$  sec.

2) EUROPE AREA

- a. When all the doors are opened after the doors were closed and locked after an alarm is ON 1 time(one time for 27 sec.), the horn alarm, hazard lamps and start inhibitor will engage again.

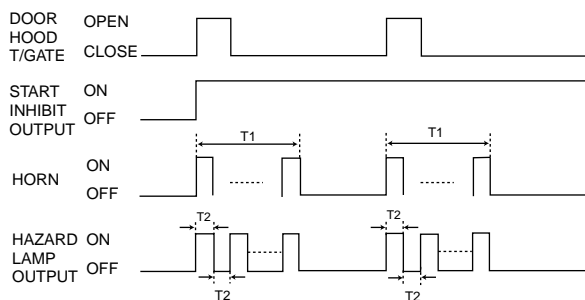

LTIF121S

T1 :  $27 \pm 2$  sec,  
 T2 :  $0.5 \pm 0.1$  sec.

- b. If an alarm occurs due to an open point of entry, and then an unaffected door is opened, the start inhibitor will remain ON, but the horn alarm will not restart.

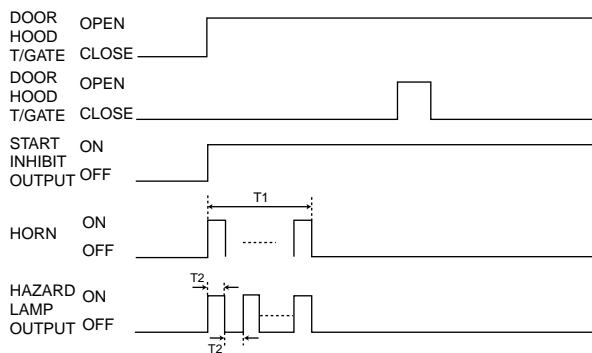

LTIF121T

T1 :  $27 \pm 2$  sec,  
 T2 :  $0.5 \pm 0.1$  sec.

**8. ALARM CLEARANCE**

- 1) When choosing LOCK on the RKE (Remote Keyless Entry) either during or after alarm activation, the alarm is cleared.
- 2) When choosing UNLOCK on the RKE either during or after alarm activation, the alarm is cleared.
- 3) If the ignition key is turned to ON for 30 seconds either during or after alarm activation the alarm will be cleared and the start inhibitor reset.
- 4) If during an alarm sequence the ignition key is turned ON and then OFF within 30 seconds, the alarm will continue.

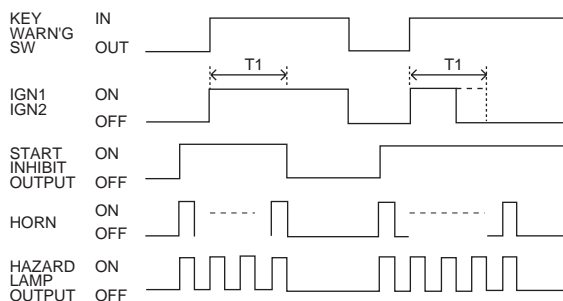

**9. Battery Separation**

- 1) When the battery is reconnected after having been disconnected/removed while in ARM mode. ARM mode continues.
- 2) When the battery is reconnected after having been disconnected/removed, and after the alarm completes, the alarm will restart.
- 3) When battery is reconnected after having been disconnected/ removed during an active alarm, the alarm sequence will restart from the beginning.

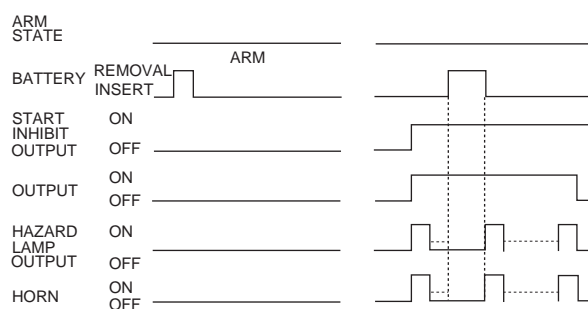

LTIF121K

LTIF121J

T1 : 30 sec.

10. PANIC

- 1) If PANIC on the RKE (Remote Keyless Entry) is activated while in ARM mode, alarm activation will be set to hold for 30 seconds. If during the 30 seconds someone breaks in, PANIC mode is cleared and the alarm activates.
- 2) When PANIC on the RKE is activated while in DISARM mode, the horn alarm and hazard lamps will activate for 30seconds.
- 3) If LOCK, UNLOCK, or PANIC is activated on the RKE control during Steps 1) or 2), PANIC mode will be cleared.
- 4) When a PANIC signal is received during or after an alarm, the alarm turns OFF, the start inhibitor is set to OFF, and panic mode is set to ON.
- 5) PANIC mode will not start if the ignition key is IN or ON even if a PANIC signal is received.
- 6) PANIC mode operates independently from entry points (door, hood, trunk) being opened or closed.

INSPECTION E9121F10

FRONT DOOR LOCK ACTUATOR INSPECTION

1. Remove the front door trim panel. (Refer to the BD group - front door)
2. Disconnect the 6P connector from the actuator.

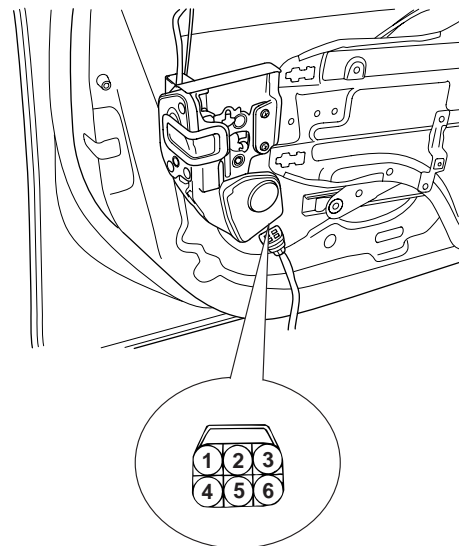

KTKD047A

3. Check actuator operation by connecting power and ground according to the table. To prevent damage to the actuator, apply battery voltage only momentarily.

Terminal Position		Terminal	
		4	6
Front left	Lock	⊖	⊕
	Unlock	⊕	⊖
Front right	Lock	⊕	⊖
	Unlock	⊖	⊕

ETKE270B

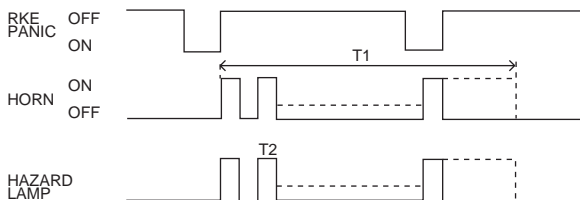

LTIF121M

T1 : 27 ± 2 sec,  
 T2 : 30 ± 1 sec,  
 T3 : 0.5 ± 0.1 sec(Duty 50%)

**REAR DOOR LOCK ACTUATOR INSPECTION**

1. Remove the rear door trim panel. (Refer to the BD group - rear door)
2. Disconnect the 6P connector from the actuator.

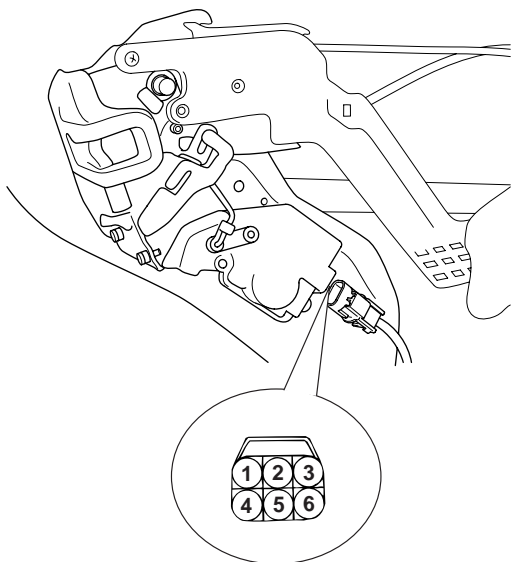

KTKD048A

**TAILGATE LOCK ACTUATOR INSPECTION**

1. Remove the tailgate trim panel.(Refer to the BD group - tailgate)
2. Disconnect the 6P connector from the actuator.

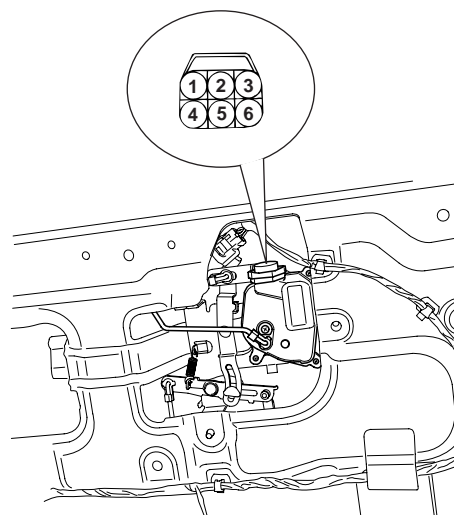

KTQE280F

3. Check actuator operation by connecting power and ground according to the table. To prevent damage to the actuator, apply battery voltage only momentarily.

3. Check actuator operation by connecting power and ground according to the table. To prevent damage to the actuator, apply battery voltage only momentarily.

Position		Terminal	
		2	3
Rear left	Lock	⊕	⊖
	Unlock	⊖	⊕
Rear right	Lock	⊖	⊕
	Unlock	⊕	⊖

ETQF275B

Position		Terminal	
		4	6
LOCK		⊕	⊖
UNLOCK		⊖	⊕

ETQF165B

**FRONT DOOR LOCK SWITCH INSPECTION**

1. Remove the front door trim panel. (Refer to the BD group - front door)
2. Disconnect the 6P connector from the actuator.

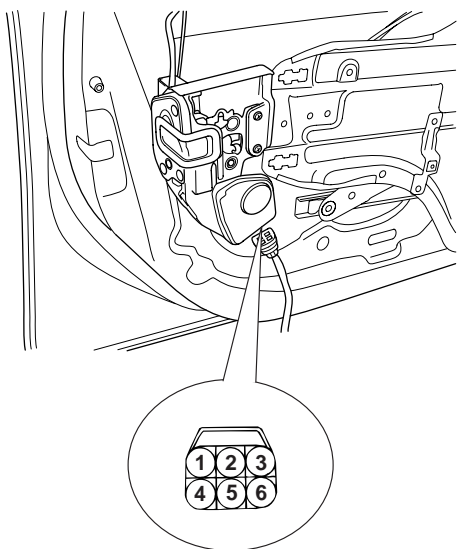

KTKD047A

**REAR DOOR LOCK SWITCH INSPECTION**

1. Remove the rear door trim panel. (Refer to the BD group - rear door)
2. Disconnect the 6P connector from the actuator.

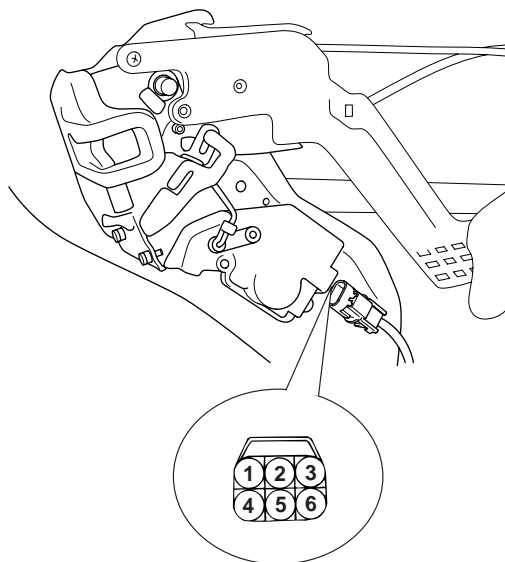

KTKD048A

3. Check for continuity between the terminals in each switch position according to the table.

3. Check for continuity between the terminals in each switch position according to the table.

Terminal		Position		
		1	2	3
Front left	Lock	○	—	○
	Unlock	○	○	
Front right	Lock	○		○
	Unlock		○	○

ETQF280A

Terminal		Position		
		4	5	6
Rear left	Lock		○	○
	Unlock	○		○
Rear right	Lock	○		○
	Unlock		○	○

ETQF280B

**TAILGATE LOCK SWITCH INSPECTION**

Remove the tailgate trim panel.

1. Remove the tailgate trim panel. (Refer to the BD group - tailgate)
2. Disconnect the 6P connector from the actuator.

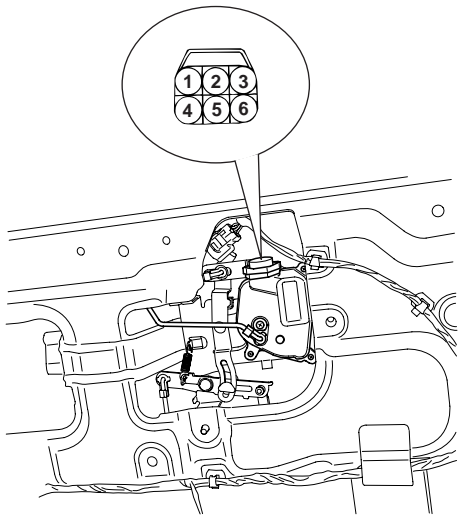

KTQE280F

3. Check for continuity between the terminals in each switch position according to the table.

Position \ Terminal	4	5	6
Lock		○ — ○	○ — ○
Unlock	○ — ○		○ — ○

LTGE282H

**DOOR SWITCH INSPECTION**

Remove the door switch and check for continuity between the terminals.

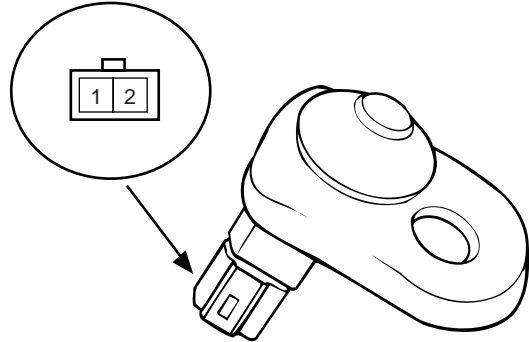

ATIE121Q

Terminal \ Position	1	2	Body (Ground)
Free(Door open)	○ — ○	○ — ○	○ — ○
Push(Door close)			

ETQF180D

**TAILGATE OPEN SWITCH INSPECTION**

1. Remove the tailgate trim panel.
2. Remove the tailgate latch after removing 3 bolts and disconnect the 1P connector from the tailgate switch.

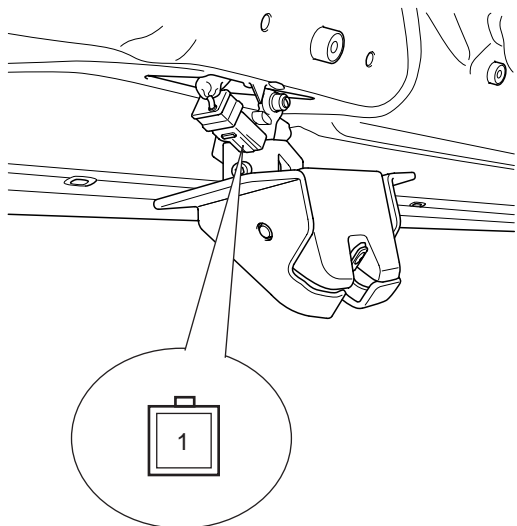

ATIE121S

3. Check for continuity between the terminals according to the table.

Terminal Position	1	Ground
Tailgate open	○ ————— ○	
Tailgate close		

LTIF175C

**HOOD SWITCH INSPECTION**

1. Disconnect the 1P connector from the hood switch.

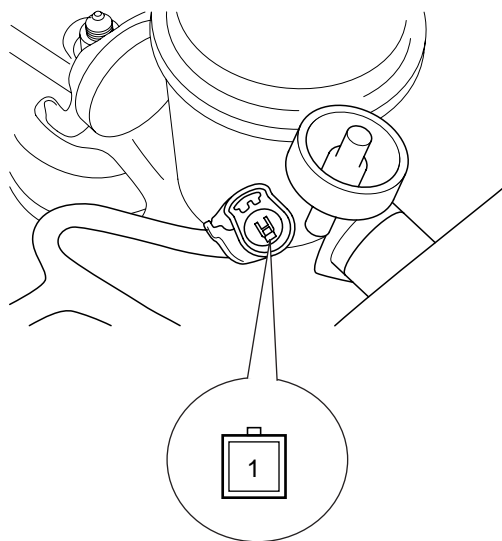

KTKD026A

2. Check for continuity between the terminals and ground according to the table.

Terminal Position	Ground (Body)	1
Hood open (Free)	○ ————— ○	
Hood close (Push)		

ETPD180B

**KEY WARNING SWITCH INSPECTION**

1. Remove the driver's crash pad lower panel. (see BD group-crash pad)
2. Disconnect the 6P connector from the key warning switch.

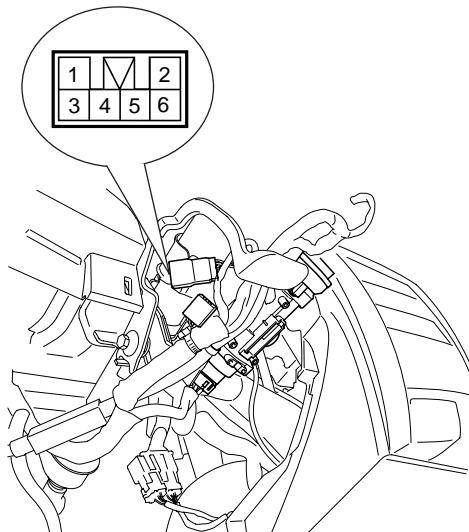

KTQE280G

**BURGLAR HORN INSPECTION**

1. Remove the burglar horn after removing 2 bolts and disconnect the 2P connector from the burglar horn.
2. Test the burglar horn by connecting battery power to the terminal 1 and ground the terminal 2.

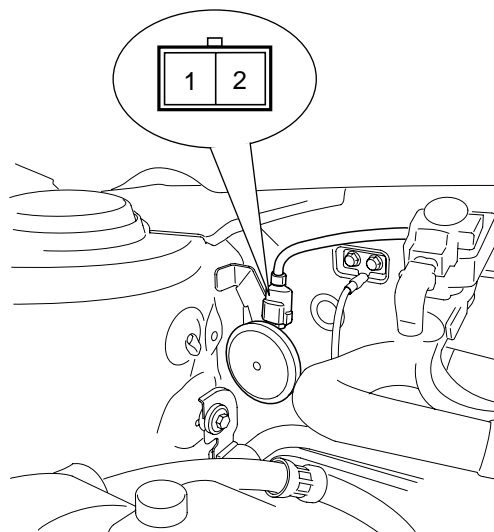

KTQE530D

3. Check for continuity between the terminals in each position according to the table.

Terminal	5	6
Key position		
Insert	○	○
Removal		

ETQF180F

3. The burglar horn should make a sound. If the burglar horn fails to make a sound replace it.

## TRANSMITTER

### SPECIFICATIONS EE4CC056

Items	Specifications
Keyless entry transmitter Power source	Lithium 3V battery (1EA)
Transmissible distance	10m or more
Life of battery	2 years or more (at 20 times per day)
Button	Door lock Door unlock Tailgate open (option) panic
Transmission frequency	433.92 MHz (EUROPE) 315.00 MHz (GENERAL)

### INSPECTION E135F3DA

1. Check that the red light flickers when the door lock or unlock button is pressed on the transmitter.
2. Remove the battery and check voltage if the red light doesn't flicker.

---

Standard voltage : 3V

---

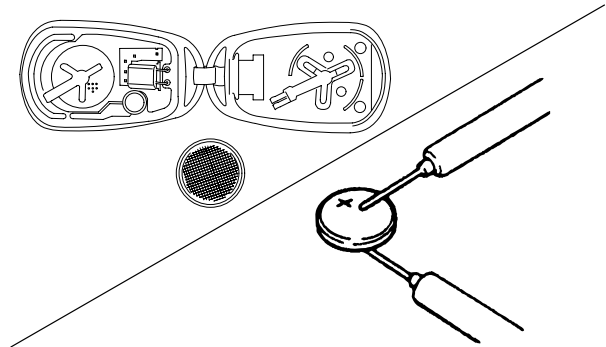

KTKD029A

3. Replace the transmitter battery with a new one, if voltage is below 3V then try to lock and unlock the doors with the transmitter by pressing the lock or unlock button five or six times.
4. If the doors lock and unlock, the transmitter is O.K, but if the doors don't lock and unlock, register the transmitter code, then try to lock and unlock the doors.
5. If the doors lock and unlock, the transmitter is O.K, but if the doors don't lock and unlock, replace the transmitter.

**TRANSMITTER CODE**

**REGISTRATION** ED6D0FF2

1. Connect the DLC cable of hi-scan to the data link connector (16 pins) in driver side crash pad lower panel, turn the power on hi-scan.

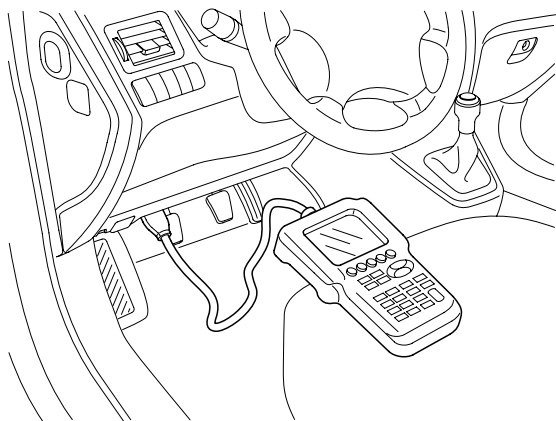

KRQE900A

2. Select the vehicle model and then do "CODE SAVING".

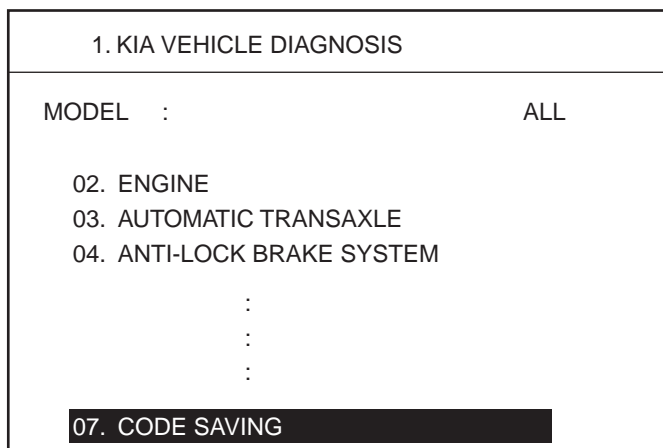

LTIF700I

3. After selecting "CODE SAVING" menu, button "ENTER" key, then the screen will be shown as below.

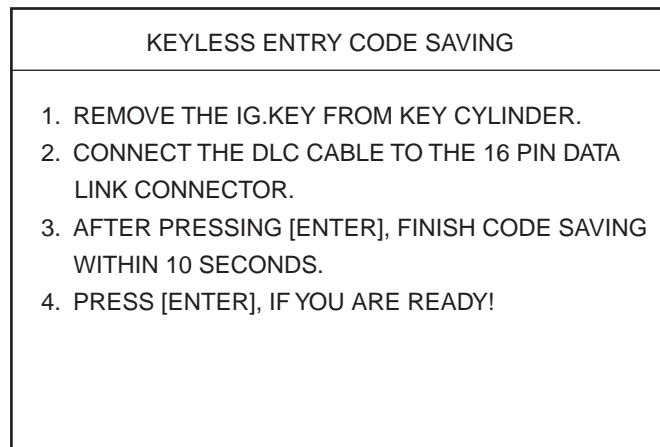

ETQF065M

4. After removing the ignition key from key cylinder, push "ENTER" key to proceed to the next mode for code saving. Follow steps 1 to 3 and then code saving is completed.

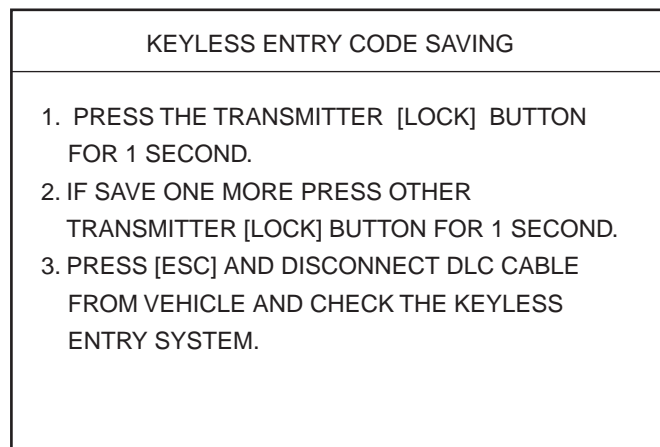

ETQF065N

## ETACS (ELECTRONIC TIME AND ALARM CONTROL SYSTEM)

### DESCRIPTION E7B5DC28

ETACS module (A) receives various input switch signals controlling time and alarm functions for the intermittent wiper timer, washer timer, rear defogger timer, seat belts warning, delayed out room lamp, central door lock, ignition key reminder, power window timer, door warning, tail lamp auto cut, crash door unlock, ignition key hole illumination, rear fog lamp control and keyless entry & burglar alarm. The ETACS module (A) is integrated in the junction box

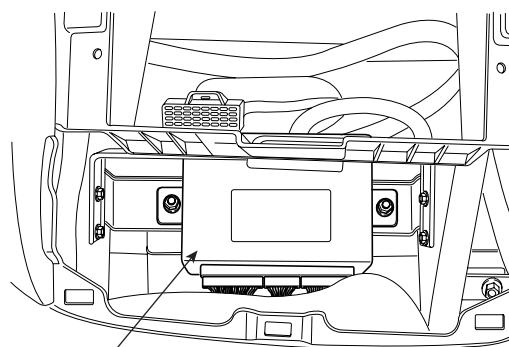

ETACS Module

LTIF140A

**SPECIFICATIONS** EFDE5CA2

Items	Specifications
Rated voltage	DC 12V
Operating voltage	DC 9 ~ 16V
Operating temperature	-22°F~176°F(-30°C~ 80°C)
Insulation resistance	100M or more
Dark current	Less than 6mA (12.8 V) - ETACS & Receiver Less than 4mA (12.8V) - ETACS
Rated load	
Burglar alarm horn	DC 12V, 3.5A (Inductance load)
Burglar alarm relay	DC 12V, 200mA (Inductance load)
Horn relay	DC 12V, 200mA (Inductance load)
Tail lamp relay	DC 12V, 200mA (Inductance load)
Front fog lamp relay	DC 12V, 200mA (Inductance load)
Rear fog lamp relay	DC 12V, 200mA (Inductance load)
Rear defogger relay	DC 12V, 200mA (Inductance load)
Tail gate safety relay	DC 12V, 200mA (Inductance load)
Power window timer relay	DC 12V, 200mA (Inductance load)
Seat belt warning indicator	DC 12V, 1.4W (Lamp load)
Key hole illumination lamp	DC 12V, 2W (Lamp load)
Room lamp	DC 12V, 10W (Lamp load)
Intermittent wiper relay	DC 12V, 200mA (Inductance load)
Central door actuator	DC 12V, 25A (Actuator load) : 5EA
Rear wiper relay	DC 12V, 200mA (Inductance load)
Windshield deicer relay	DC 12V, 200mA (Inductance load)
Door lock relay	DC 12V, 200mA (Inductance load)
Door unlock relay	DC 12V, 200mA (Inductance load)
Hazard lamp relay	DC 12V, 200mA (Inductance load)
Driver door unlock relay	DC 12V, 200mA (Inductance load)
Mirror folding relay	DC 12V, 200mA (Inductance load)
Folding mirror relay	DC 12V, 200mA (Inductance load)

# ELECTRONIC TIME AND ALARM CONTROL MODULE

## CIRCUIT DIAGRAM ED14B9B0

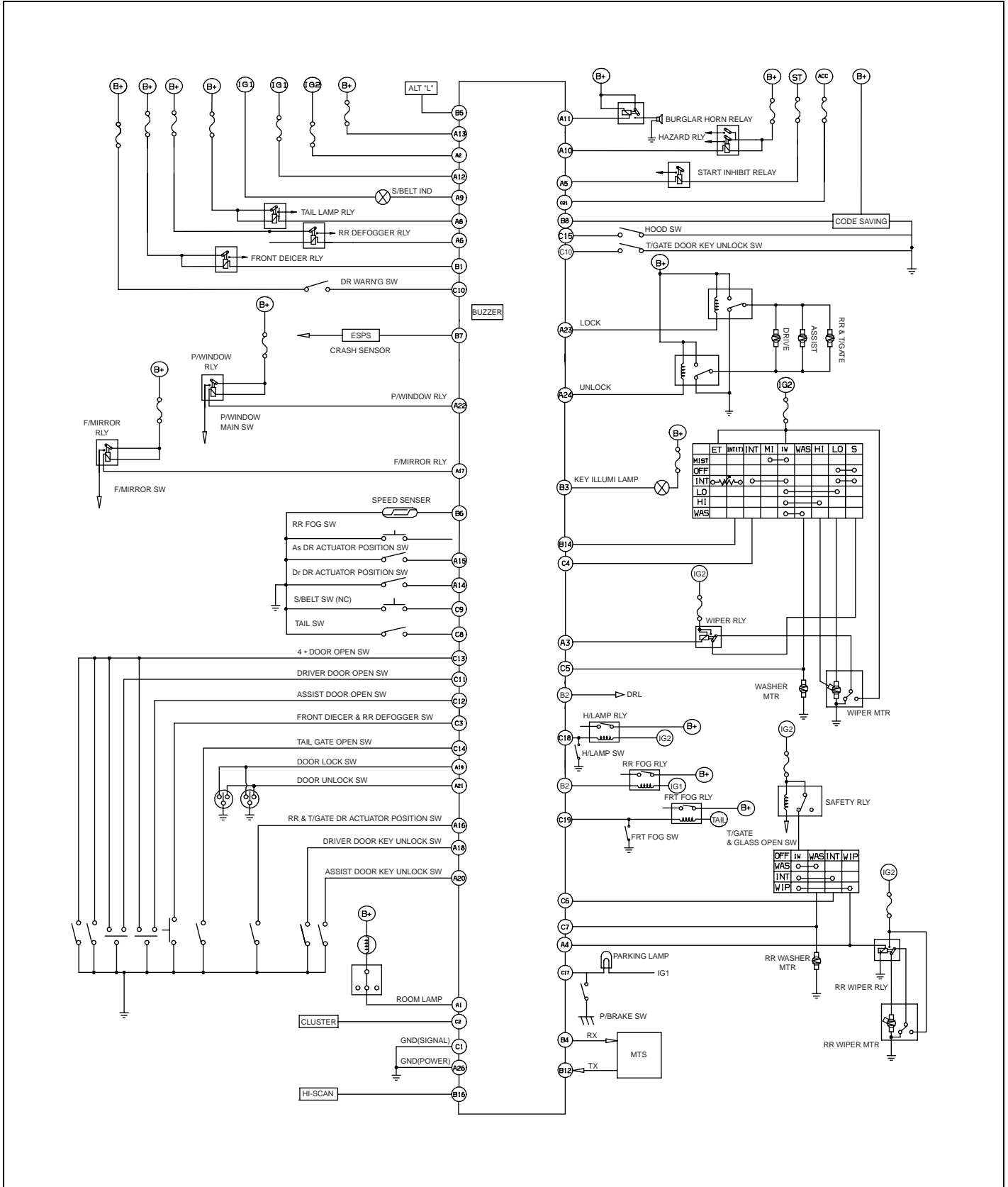

**ETACS CONNECTOR TERMINALS**

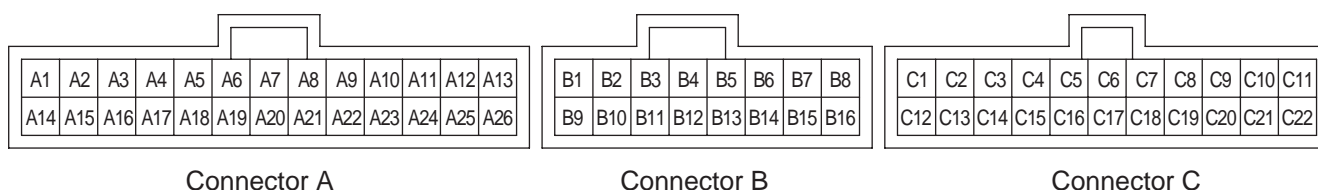

LTIF140D

Terminal No.	Connector A	Connector B	Connector C
1	Room lamp	Windshield deicer relay	Ground
2	IGN 2	Rear fog lamp relay	Cluster
3	Wiper relay	Key hole illumination	Windshield deicer & Rear defogger switch
4	Rear wiper relay	-	Intermittent wiper switch
5	Start inhibit relay	Alternator (L)	Washer switch
6	Rear defogger relay	Speed sensor	Intermittent rear wiper switch
7	D.R.L	Crash sensor	Rear washer switch
8	Tail lamp relay	Code saving	Tail lamp switch
9	Seat belt indicator	-	Seat belt switch
10	Hazard lamp relay	-	Key warning switch
11	Burglar horn relay	-	Driver door open switch
12	IGN1	-	Assist door open switch
13	B+ [For ETACS]	-	4 door open switch
14	Driver door unlock switch	Intermittent wiper volume	Tailgate open switch
15	Assist door unlock switch	-	Hood switch
16	Rear & Tailgate unlock switch	Diagnosis	Tailgate door key unlock switch
17	Mirror folding relay		Parking brake switch
18	Driver door key unlock switch		Head lamp switch
19	Door lock switch		Front fog lamp switch
20	Assist door key unlock switch		Rear fog lamp switch
21	Door unlock switch		ACC
22	Power window relay		-
23	Door lock relay		
24	Door unlock relay		
25			
26	Ground		

ETACS MODULE INPUT SIGNAL TEST

Pin No.	Input signal name	Test condition	Measured value	Ordinary
A1	Room lamp	Door open	1V or less	10V or more
A2	IGN 2	Ignition switch ON	Battery voltage	1V or less
A3	Wiper relay	Intermittent wiper, washer switch ON	1V or less	10V or more
A4	Rear wiper relay	Rear intermittent wiper, washer switch ON	Battery voltage	1V or less
A5	Start inhibit relay	Engine start condition	1V or less	10V or more
A6	Rear defogger relay	Windshield deicer switch & Rear defogger switch ON	1V or less	10V or more
A7	D.R.L	Tail lamp switch ON	1V or less	10V or more
A8	Tail lamp relay	Tail lamp switch ON	1V or less	10V or more
A9	Seat belt indicator	Seat belt is unbuckled	1V or less / 10V or more (1sec period)	1V or less
A10	Hazard lamp relay	Remote control LOCK/UNKOCK	1V or less / 10V or more (1sec period)	10V or more
A11	Burglar horn relay	Remote control LOCK/UNKOCK	1V or less / 10V or more (1sec period)	10V or more
A12	IGN1	Ignition switch ON	Battery voltage	1V or less
A13	B+ [For ETACS]	Constant	Battery voltage	1V or less
A14	Driver door unlock switch	Driver door UNLOCK	5~12V	1V or less
A15	Assist door unlock switch	Assist door UNLOCK	5~12V	1V or less
A16	Rear & Tailgate unlock switch	Rear & Tail gate UNLOCK	5~12V	1V or less
A17	Mirror folding relay	ACC switch ON	1V or less	10V or more
A18	Driver door key unlock switch	Driver door key UNLOCK switch ON	5~12V	1V or less
A19	Door lock switch	Door LOCK ON	5~12V	1V or less
A20	Assist door key unlock switch	Assist door key unlock switch ON	5~12V	1V or less
A21	Door unlock switch	Door unlock switch ON	5~12V	1V or less
A22	Power window relay	Ignition switch ON	1V or less	10V or more
A23	Door lock relay	Remote control & Central door LOCK	1V or less	10V or more
A24	Door unlock relay	Remote control & Central door UNLOCK	1V or less	10V or more
A25	-	-	-	-
A26	Ground	Constant	1V or less	1V or less
B1	Windshield deicer relay	Windshield deicer & Rear defogger switch ON	1V or less	10V or more
B2	Rear fog lamp relay	Rear fog lamp switch ON	1V or less	10V or more

**ETACS (ELECTRONIC TIME AND ALARM CONTROL SYSTEM)**

Pin No.	Input signal name	Test condition	Measured value	Ordinary
B3	Key hole illumination	Key hole illumination ON	1V or less	10V or more
B5	Alternator (L)	Engine start condition	Battery voltage	1V or less
B6	Speed sensor	Speed sensor input	1V or less / 10V or more (1sec period)	10V or more
B7	Crash sensor	Crash sensor signal input	1V or less	10V or more
B8	Code saving	Code saving	1V or less	10V or more
B14	Intermittent wiper volume	Intermittent wiper volume ON	12V 0V	10V or more
B16	Diagnosis	Diagnostic tool signal	1V or less	10V or more
C1	Ground	Constant	1V or less	10V or more
C2	Cluster	Cluster signal input	1V or less	10V or more
C3	Windshield deicer & Rear defogger switch	Windshield deicer & Rear defogger switch ON	1V or less	10V or more
C4	Intermittent wiper switch	Intermittent wiper switch ON	10V or more	1V or less
C5	Washer switch	Washer switch ON	10V or more	1V or less
C6	Intermittent rear wiper switch	Intermittent rear wiper switch ON	10V or more	1V or less
C7	Rear washer switch	Rear washer switch ON	10V or more	1V or less
C8	Tail lamp switch	Tail lamp switch ON	5-12V	1V or less
C9	Seat belt switch	Seat belt is unbuckled	1V or less	10V or more
C10	Key warning switch	Key is inserted into the ignition switch	10V or more	1V or less
C11	Driver door open switch	Driver door open	1V or less	10V or more
C12	Assist door open switch	Assist door open	1V or less	10V or more
C13	4 door open switch	4 door open	1V or less	10V or more
C14	Tailgate open switch	Tailgate open	1V or less	10V or more
C15	Hood switch	Hood open	1V or less	10V or more
C16	Tailgate door key unlock switch	Tailgate door key unlock	1V or less	10V or more
C17	Parking brake switch	Parking brake switch ON	1V or less	10V or more
C18	Head lamp switch	Head lamp switch ON	1V or less	10V or more
C19	Front fog lamp switch	Front fog lamp switch ON	1V or less	10V or more
C20	Rear fog lamp switch	Rear fog switch ON	1V or less	10V or more
C21	ACC	ACC	10V or more	1V or less

**REPLACEMENT** EFB8CDAA

1. Disconnect the negative (-) battery terminal.
2. Remove the center facia panel (C) after pulling it by using regular screw driver (-) at part (A). Take care of fixing clips (B).

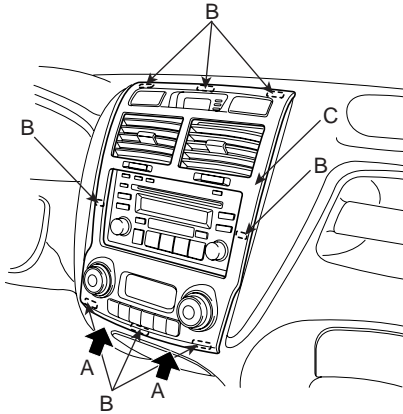

ATIE021A

3. Remove the connectors.
4. Remove the mounting screws then remove the audio unit (A) assembly.

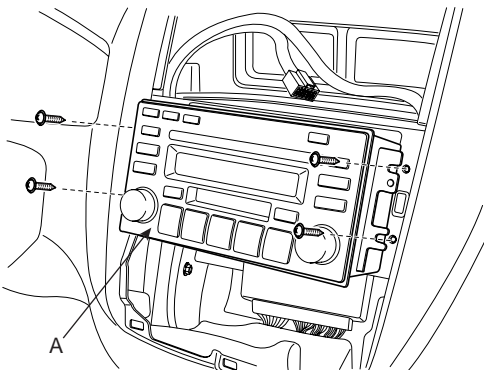

ATIE021E

5. Remove the antenna cable and ETACS module (A) after removing 2 nuts.

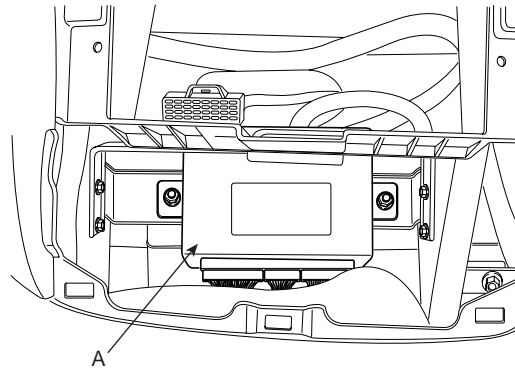

ATIE140E

6. Installation is the reverse of removal.

**INSPECTION** E7CD9EA3

Verify each components operation using related timing charts.

**1. TAIL LAMP AUTO CUT**

- 1) With the tail lamp switched ON, if the ignition is switched OFF and the driver's door opened, the tail lamp should be automatically turned OFF.
- 2) With the ignition switch ON, if the driver's door is opened and the ignition is switched to OFF, the tail lamp should be automatically turned OFF.
- 3) When the tail lamp is cut automatically and the tail lamp switch is turned OFF and ON, the tail lamp illuminates and auto cut function is cancelled.
- 4) When the tail lamp is cut automatically and the ignition key is inserted, the tail lamp illuminates and auto cut function is canceled.
- 5) In case of battery disconnection-connection in AUTO CUT MODE, preserve AUTO CUT MODE.

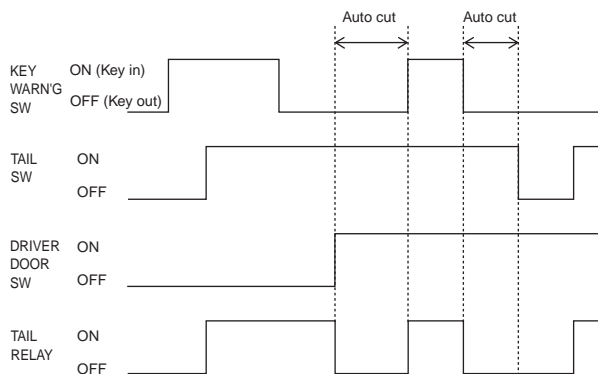

LTGE141A

**2. IGNITION KEYHOLE ILLUMINATION**

- 1) Ignition keyhole illumination is turned ON when the driver or passenger door is opened.
- 2) The "ON" state for ignition keyhole illumination is delayed 10 seconds when the door is closed as in Step 1).
- 3) Ignition keyhole illumination is turned off if the ignition switch is turned ON as in Step 1) & 2).
- 4) Ignition keyhole illumination is turned off if ARM state is entered. See Steps 1) & 2).

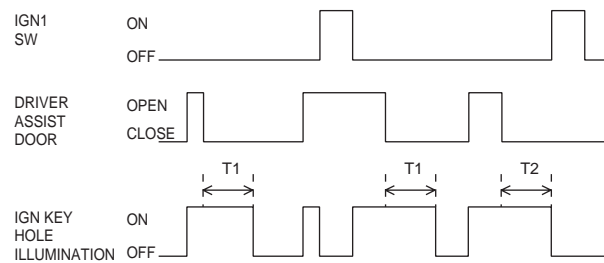

LTGE141B

T1 : 10 ± 1 sec,  
T2 : 0 ~ 10 sec.

**3. DELAYED ROOM LAMP**

- 1) When the first door (driver, or assist or 4doors) is opened, Room lamp is turned on.
- 2) When the door is closed, the room lamp is fade out for 2 seconds after there is on for 30 seconds.
- 3) Regardless of IGN ON/OFF in DOOR OPEN state, ROOM LAMP output is ON.
- 4) When Remote control UNLOCK is received, ROOM LAMP is turned on for 30 seconds.
- 5) While room lamp is on due to Remote control unlock, if another Remote control unlock is received, then room lamp is again on for 30 sec.
- 6) During on for 30 seconds, when Remote control LOCK receive (ARM condition) or IGN2 is ON, put out lights after sensitized for 2 seconds.

- 7) During ON for 30 seconds, when produce all doors LOCK in Dr/As/4DOOR CLOSE state (But, Hood & Tail gate Door exception), put out lights after sensitize for 2 seconds.
- 8) 30 seconds Delay function is suspended when it is DOOR OPEN during 30 seconds Delay action regard to Remote control UNLOCK.(Function achievement by sensitization ROOM LAMP)

- 2) Installation of the battery should not change the state of the locks. (KNOB is LOCK state, do not produce LOCK output even if connect BATTERY despite UNLOCK state,)
- 3) Signals of duration less than 60 milliseconds will be ignored.
- 4) When UNLOCK is input during LOCK output, the LOCK output stops immediately and the UNLOCK output continues. (Vice versa)
- 5) When the LOCK/UNLOCK signal is received by the remote control, the LOCK/UNLOCK output continues for 0.5 seconds.
- 6) When the hazard lamp is on during the LOCK/UNLOCK by the remote control, the LOCK/UNLOCK signal by the remote control shall be ignored.

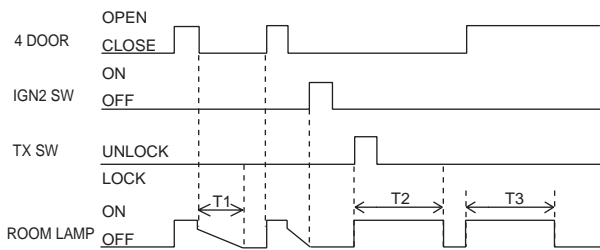

ATGE141C

T1 : 5.5 ±1 sec.,  
 T2 : 30 ±5 sec.,  
 T3 : 20 ±1 min.

4. CENTRAL DOOR LOCK/UNLOCK

1) Central door lock/unlock

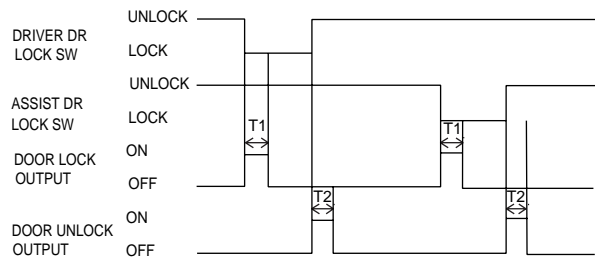

LTGE141D

T1,2 : 0.5 ±0.1 sec.

Function \ Option		Central door Lock	Transmitter (RKE)
Door key UNLOCK	Driver	All unlock	All unlock
	Assist	All unlock	All unlock
Transmitter (RKE)	Lock	-	All lock
	Unlock	-	All unlock
Driver knob	Lock	All lock	All lock
	Unlock	All unlock	Driver unlock
Assist knob	Lock	All lock	All lock
	Unlock	All unlock	Assist unlock
Main door Lock switch	Lock	All lock	All lock
	Unlock	All unlock	All unlock

LTIF141Q

**5. CRASH DOOR UNLOCK**

- 1) If IG1 is on and a crash signal is received, send an unlock pulse to the door locks.
- 2) This function is prior in all door lock functions.
- 3) If door lock switch is locked in door lock switch is unlocked state, after the first crash unlock output, issue unlock pulse for again 5 sec.
- 4) Only one crash unlock can occur during one ignition on cycle.

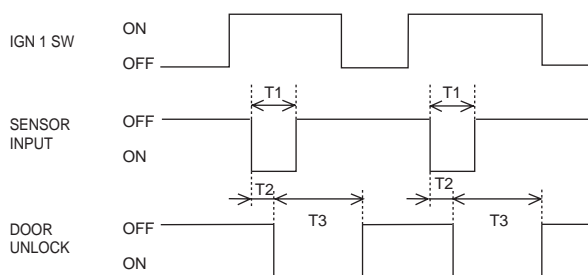

LTIF141F

T1 :  $0.2 \pm 0.02$  sec.,  
 T2 : 0.04 sec.,  
 T3 :  $5 \pm 0.5$ sec.

**6. IGNITION KEY REMINDER**

- 1) If the key is in the ignition and the driver's door or assist door is open and the vehicle is locked using driver's knob or assist knob, then the central locking system will issue an unlock pulse of duration 1 second to the all doors, thus preventing locking of the vehicle.
- 2) If a Knob remains locked, then the central locking shall issue a maximum of 3 pulses of 0.5 second duration to unlock the vehicle. If during these pulses, the door lock knob becomes unlocked, stop the next pulse.
- 3) If during the 3 pulses door is closed or the key is removed, stop the next pulse.

- 4) If after the 3 unlock pulses the knob remains in the locked state, the condition is remembered. 1sec unlock (reset) pulse is issued if there is a change in any of the following inputs: Door warning switch, driver door switch, assist door switch, driver door lock switch, assist door lock switch.
- 5) If a door is open and locked and a key is inserted, issue one unlock pulse of duration 1 sec. (At KEY is inserted after driver seat unlock in 2 TURN UNLOCK vehicle, no issue one unlock pulse)
- 6) When Door is closed in 0.5 seconds after LOCK, an unlock pulse of duration 1sec shall be issued.
- 7) When is Power window main switch LOCK, issue one unlock pulse immediately after 0.5 second LOCK. ( Key warning switch = Keyless switch)
- 8) To further prevent locking of keys in ignition, a guard time of 0.5 seconds is introduced after a door is closed. When key is in ignition and the door changes from open to close and a lock occurs within 0.5 sec, an unlock pulse of duration 1 sec shall be issued.
- 9) If door warning switch is off and ignition input is on then ignition key reminder function is disabled. (If vehicle speed is greater than 3 km/h, ignition key reminder function is disabled.)

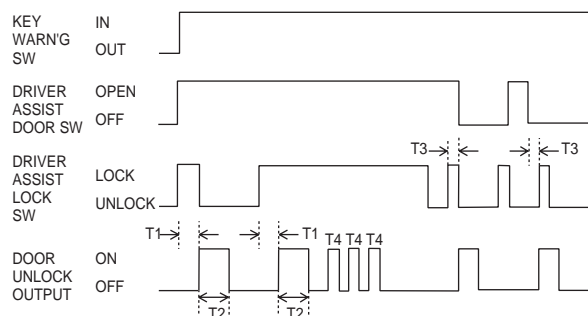

LTIF141G

T1 : MAX 0.1 sec.,  
 T2 : 1.0 sec.,  
 T3 : 0 sec. < T3 < 0.5 sec.  
 T4 : 0.5 sec.

7. SEAT BELT WARNING TIMER

- 1) When the ignition is switched ON, the seat belt warning indicator will illuminate (period: 1.0 sec., duty rate: 50%) and the chime bell will sound (period: 1.0 sec., duty rate: 50%) for total of 6 seconds.
- 2) If the ignition is switched off while the seat belt warning indicator and chime bell are active (Step 1) the indicator and chime bell will be switched OFF. If the seat belt is sensed as fastened during indicator and chime bell output, the chime bell will switch OFF however the seat belt warning indicator will stay illuminated for the remaining seconds.
- 3) If the seat belt is removed, with the ignition switched ON, the seat belt warning indicator and chime bell will activate for 6 seconds.

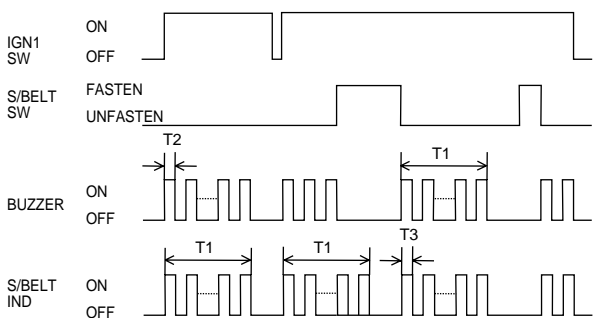

LTGE141H

T1 : 6 ± 1 sec.,  
 T2 : 0.5 ± 0.1 sec (ON TIME),  
 T3 : 0.3 ± 0.1 sec. (ON,OFF TIME)

8. KEY OPERATED WARNING

- 1) If the key is in the ignition and the driver's door is opened, the buzzer is sounded (period: 1.0 sec., duty rate: 50%).
- 2) If the ignition key is removed, or the door is closed, the buzzer is switched OFF immediately.

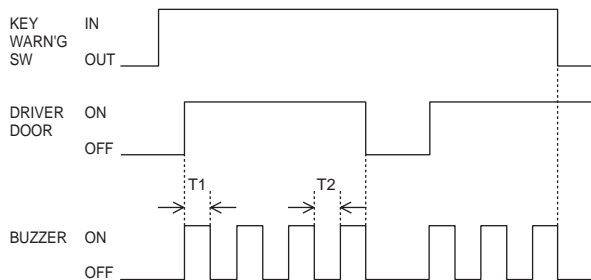

LTGE141I

T1,T2 : 0.5±0.1sec.

9. WINDSHIELD DEICER & REAR DEFOGGER TIMER

- 1) Once ALT "L" is ON, if the defogger is switched ON, the defogger will stay ON for 20 minutes duration.
- 2) If defogger switch is pressed again (see Step 1), or if ignition is switched OFF, the defogger will shut OFF.

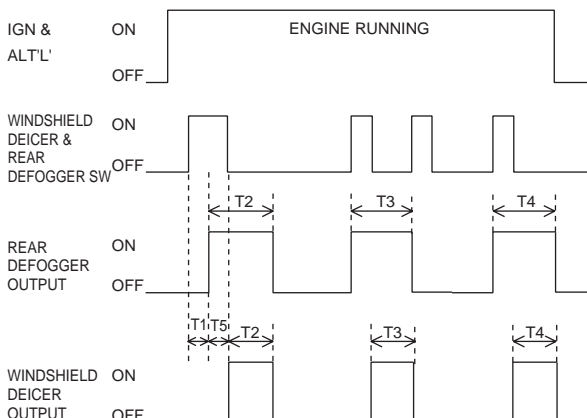

LTIF141J

T1 : 0.06 ± 0.01 sec.,  
 T2 : 20 ± 1 min.

**10. POWER WINDOW TIMER**

- 1) When the ignition is switched OFF, power window output remains ON for 30 seconds and then turns OFF.
- 2) Related to Step 1), if the driver's door or assist door is opened, window power output is turned OFF immediately.
- 3) When the driver's door or assist door is opened, the power window relay output is turned OFF immediately.

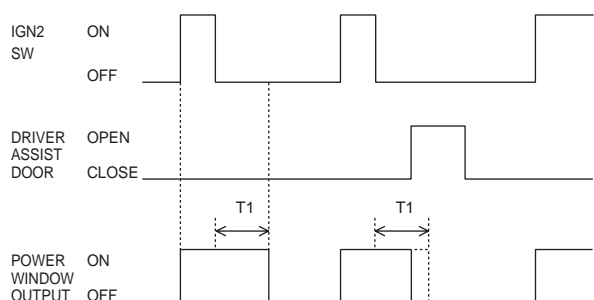

LTGE141K

T1 : 30 ± 3 sec.

**11. REAR WIPER AND WASHER**

- 1) If rear washer switch is turned on while the ignition switch is ON, rear wiper output will turn ON after 0.3 sec.
- 2) If rear washer switch is turned OFF, rear wiper output remains ON for up to 3.8 sec.(T2).

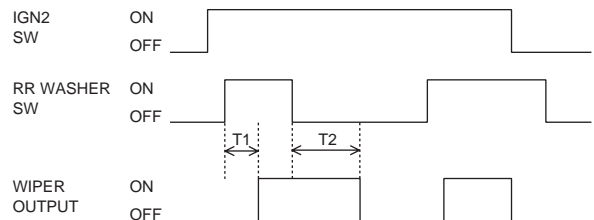

LTGE141L

T1 : 0.3  
T2 : 2.5 ~ 3.8 sec.

- 3) When the ignition switch is ON, if the intermittent rear wiper switch is turned ON, rear wiper output will remain ON for up to 0.7 sec. (T3).

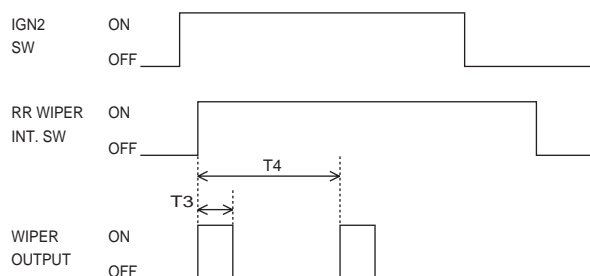

LTGE141M

T3 : 0.7 ± 0.1sec.,  
T4 : 5 ± 0.5sec.

**12. WIPER RELATED TO WASHER**

- 1) When the ignition switch is turned ON:
  - If washer switch is turned on, wiper output is ON after 0.3 sec. (T5)
  - If washer switch is turned OFF, wiper output is OFF after 3.8 sec. (T6)
- 2) If the washer switch is turned OFF within 0.6 sec.(T2) of the ignition switch the wiper will remain ON for up to 0.7 sec.(T3) from the moment that washer switch is turned OFF.

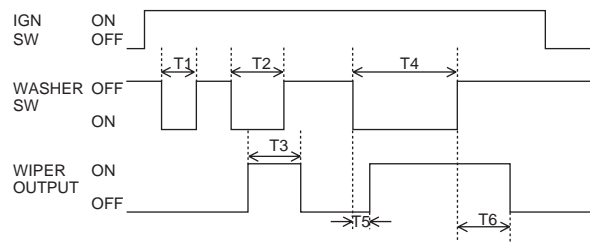

LTIF141N

T1 : Less than 0.2 sec.  
T2 : 0.2 ~0.6 sec. (MIST Function)  
T3 : 0.7 ± 0.1sec.  
T4 : More than 0.6 sec.  
T5 : 0.3sec.  
T6 : 2.5 ~3.8 sec.

13. VARIABLE INTERMITTENT WIPER (WINDSHIELD WIPER)

- 1) With the ignition switch ON, if the intermittent wiper switch is turned on, wiper output is ON according to the setting.
- 2) When the intermittent wiper switch is ON, if the ignition switch is turned ON, wiper output is ON.

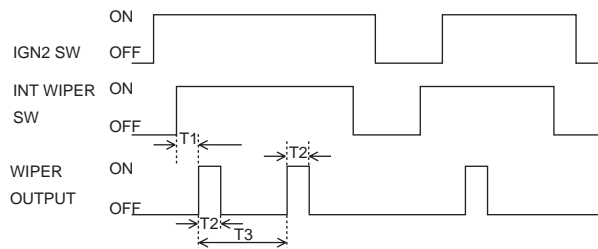

LTIF1410

- T1 : MAX 0.5 sec.,
- T2 :  $0.7 \pm 0.1$ sec.,
- T3 :  $2.6 \pm 0.7$  sec. (FAST),
- T3 :  $18.0 \pm 1.0$ sec. (SLOW) Car speed 0 Km

14. OVER SPEED WARNING (Middle East area)

If vehicle runs over 120km/h, the cluster input is to be set. When the cluster input indicates that vehicle runs over 120km/h, the over speed warning starts.

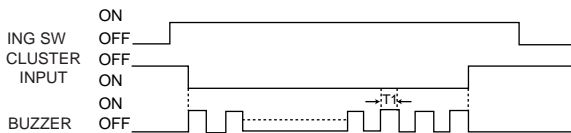

LTGE141T

- T1 :  $1.0 \pm 0.1$ sec.

15. Rear fog lamp control

In case of (IGN1 & tail output) and [ (head lamp low output) or (front fog lamp output) is turned ON ], if rear fog switch is pushed, rear fog lamp is turned ON.

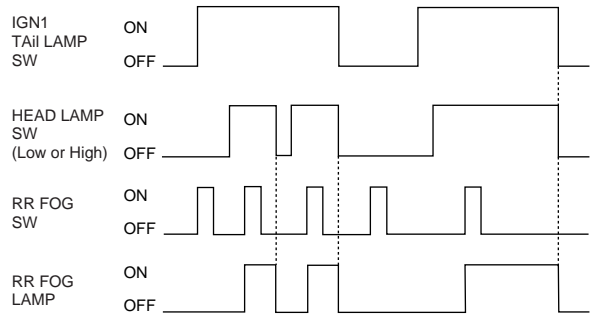

LTGE141S

16. AUTO DOOR LOCK

- 1) When Ignition 2 is on, if the vehicle speed is greater than 40km/h, then door lock activated within 2-3 sec (although one among All Door is Unlock state)
- 2) While drive more than 40km/h even if manufacture Unlock, automatically Door is Lock.
- 3) When Door Lock SW is Unlock state after Auto Door Lock, Door Lock is output 3 times by 0.5 second ON/OFF cycles.
- 4) If change in 3) clause, occur output OFF do.
- 5) After 3) clause, do Reset when is IGN2 OFF after preservation just as it is if there is no Lock change.
- 6) After Lock state conversion in Unlock state after 3 rd output, in case is Unlock again, output 1 times.
- 7) Output again 3 times when produce Unlock in Door except Door that try 3 times.
- 8) Auto Door Lock function malfunctions in Crush Unlock.

**ETACS (ELECTRONIC TIME AND ALARM CONTROL SYSTEM)**

**BE -75**

- 9) It is IGN2 ON in Unlock state to one All Door Lock SW, When Car Speed keeps state more than 40km/h more than  $2.5 \pm 0.5$  second (T1) output Door Lock 3 times by 0.5 second ON/OFF cycles.

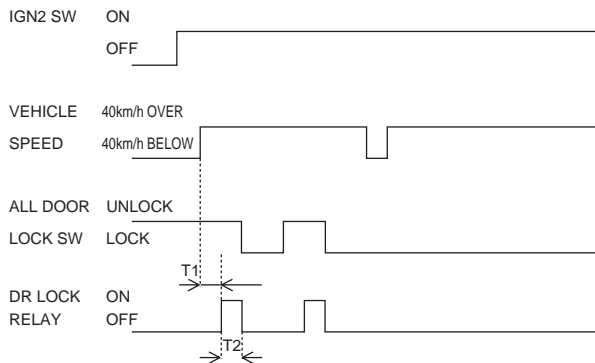

LTIF141V

T1 :  $2.5 \pm 0.5$ sec.  
T2 : 0.5 sec.

- 2) While execute 2) clause in following case, output does OFF immediately.
- If the vehicle speed falls below 10km/h the chime buzzer is deactivated.
  - If the park brake switch is off, the chime buzzer is deactivated.

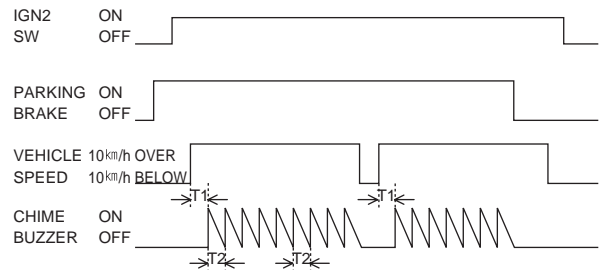

LTIF141S

T1 :  $2.5 \pm 0.5$  sec.  
T2 :  $1.0 \pm 0.1$  sec.

**17. KEY REMOVE DOOR UNLOCK**

Issue on door unlock pulse in case is locked state between all door at KEY separation after IGN SW OFF.

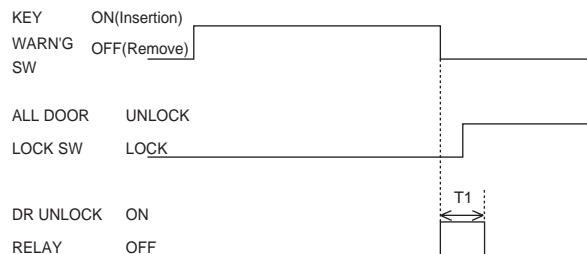

LTIF141R

T1:  $0.5 \pm 0.5$ sec.

**18. PARKING START WARNING**

- 1) When Ignition 2 is on and the park brake switch is on, if the vehicle speed is greater than 10km/h, then the chime buzzer is activated within 2 - 3 sec at a period of 1sec.

**19. MIRROR FOLDING**

- 1) When ACC switch is on, the folding mirror relay output is turned on.
- 2) When acc switch is turned off the folding mirror relay output is maintained on for 30 seconds and then turned off.

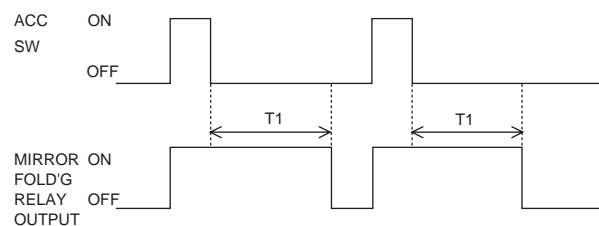

LTIF141U

T1 :  $30 \pm 3$  sec.

# FUSES AND RELAYS

## COMPONENTS E65BDEEF

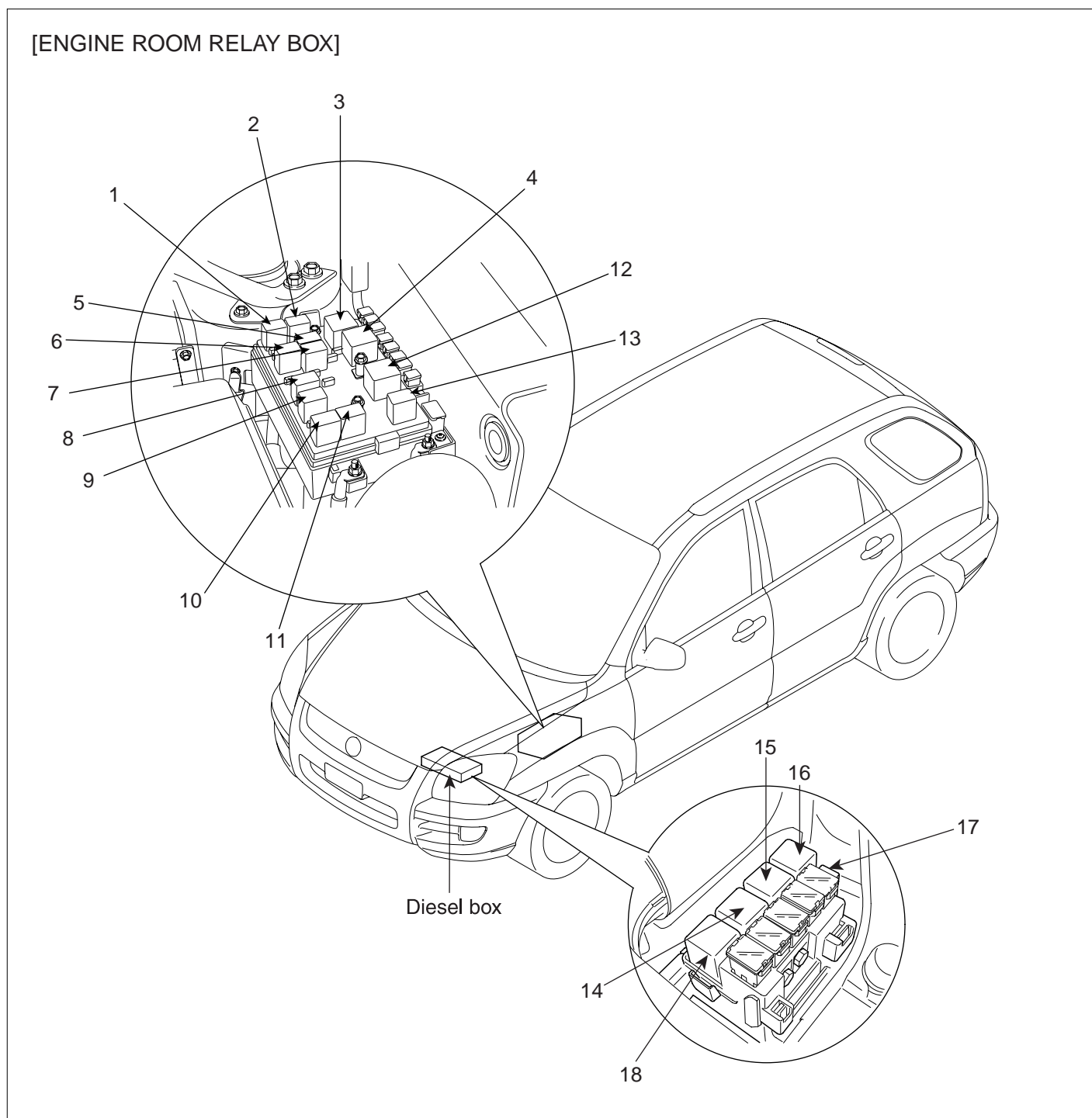

- 1. A/T relay
- 2. Air-conditioner relay
- 3. Main relay
- 4. Start relay
- 5. Fuel pump relay
- 6. Wiper relay

- 7. Windshield deicer relay
- 8. Front fog lamp relay
- 9. Head lamp relay(Low)
- 10. Head lamp relay(High)
- 11. Horn relay
- 12. Condenser fan #1 relay

- 13. Condenser fan #2 relay
- 14. PTC heater relay #1
- 15. PTC heater relay #2
- 16. PTC heater relay #3
- 17. Fuel filter heater relay
- 18. Glow relay

[Passenger compartment relay box]

Passenger compartment junction block

ICM relay box

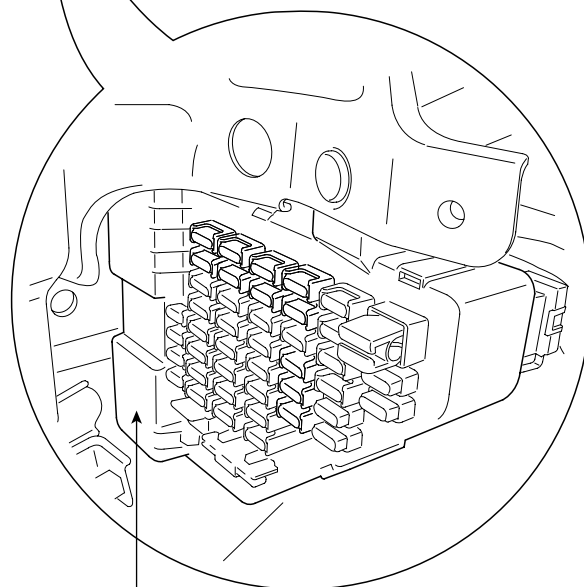
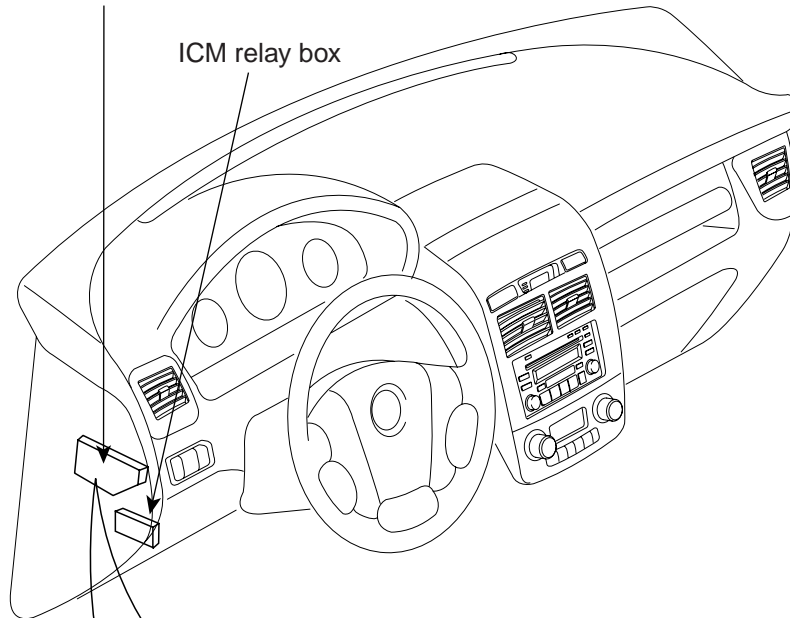

Power window relay, Tail lamp relay, Rear deffogger relay,  
Hazard lamp relay, Tailgate relay, Safety relay

# RELAY BOX (ENGINE COMPARTMENT)

COMPONENT EB4ABB1C

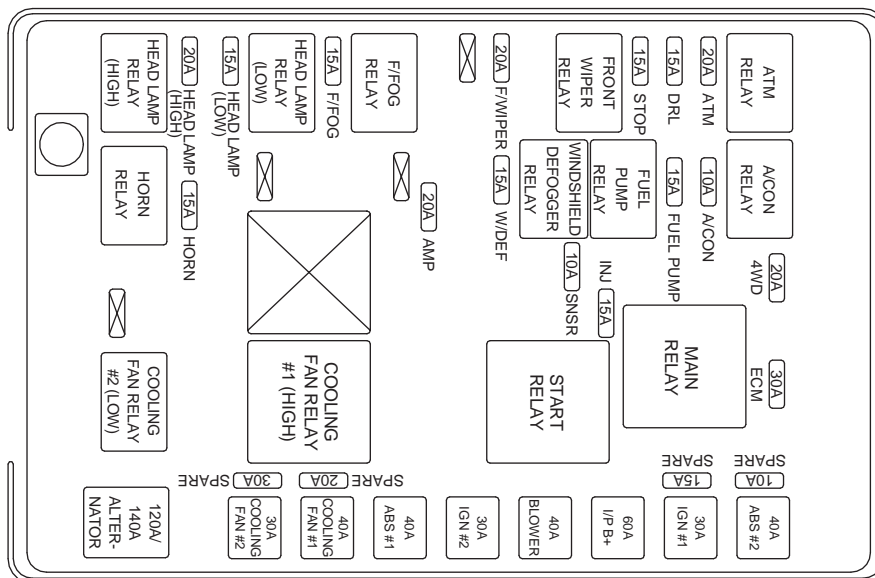

## CIRCUIT

FUSE	(A)	Circuit Protected
ALTERNATOR	120A/140A	Battery, Alternator
I/P B+	60A	I/P Junction Box
BLOWER	40A	Blower Relay
ABS #1	40A	ABS Control Module, ESP Control Module
ABS #2	40A	ABS Control Module, ESP Control Module
COOLING FAN #1	40A	Cooling Fan Relay #1 (HIGH)
COOLING FAN #2	30A	Cooling Fan Relay #2 (LOW)
IGN #1	30A	Ignition Switch (IG1, ACC)
IGN #2	30A	Ignition Switch (IG2, START), Start Relay
ECM	30A	Main Relay, Fuel Pump Relay, SNSR 10A, INJ 10A, ECM
4WD	20A	4WD ECM
F/WIPER	20A	Front Wiper Relay, Front Wiper motor, Multifunction Switch
AMP	20A	Sub Woofer, AMP #1
HEAD LAMP (HIGH)	20A	Head Lamp Relay (HIGH)
ATM	20A	ATM Relay
FUEL PUMP	15A	Fuel Pump Relay
INJ	15A	ECM, Injector, Stop Lamp Switch, EGR Actuator, ISA, Throttle Flap Actuator, Variable Intake Manifold Control Motor #1
STOP	15A	Stop Lamp Switch
W/DEF	15A	Windshield Defogger Relay
F/FOG	15A	F/FOG Relay
HEAD LAMP (LOW)	15A	Head Lamp Relay (LOW)
HORN	15A	Horn Relay, Alternator, Siren Relay
A/CON	10A	A/CON Relay
SNSR	10A	MAF Sensor, PTC HTR Relay, Glow Plug Relay, O <sub>2</sub> Sensor, ECM, SMATRA Crank Shaft Position Sensor
DRL	15A	DRL Control Module

✳️ USE THE DESIGNATED FUSE ONLY

DIESEL BOX

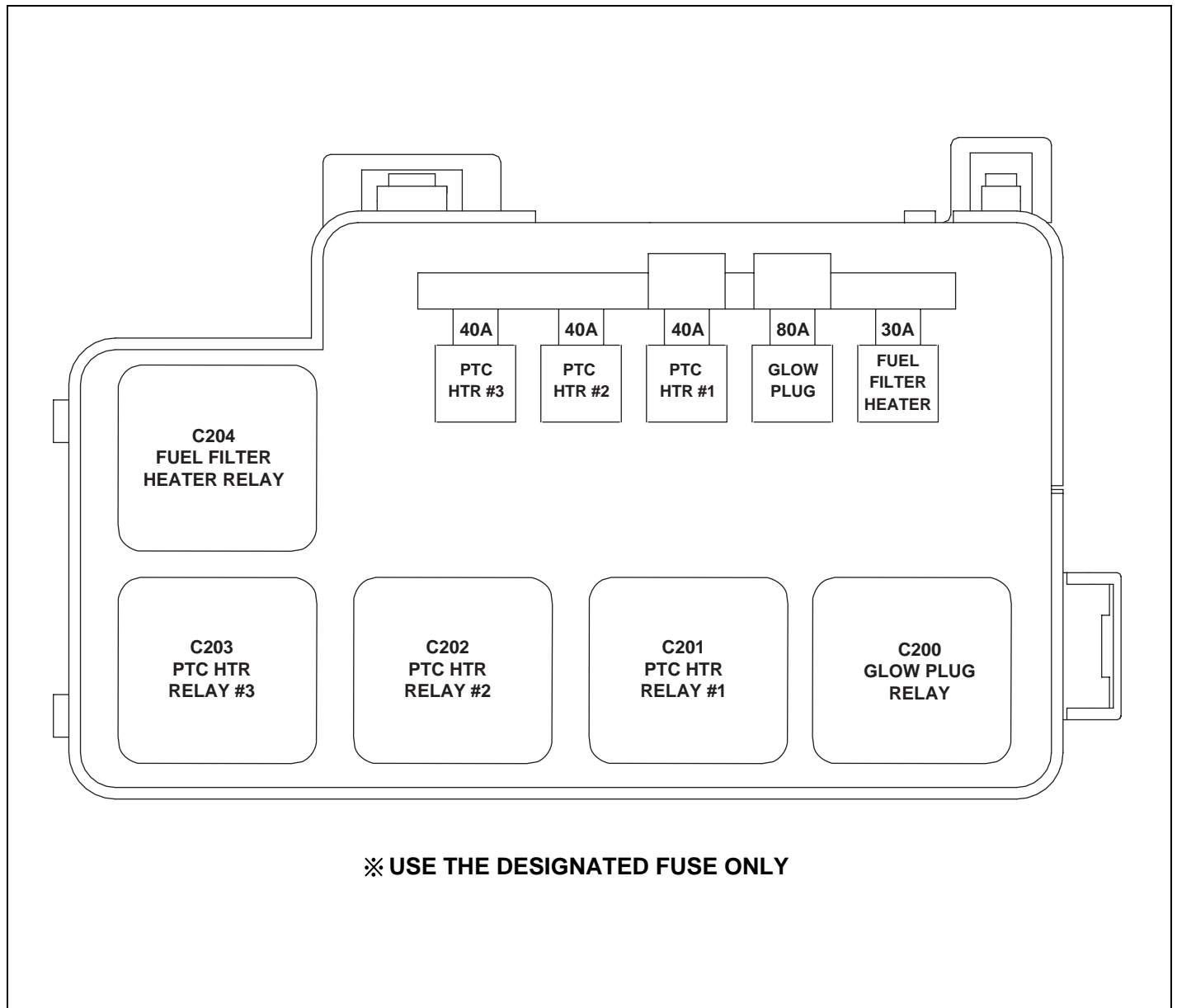

LTIF220G

**INSPECTION** EB1BCECF

**POWER RELAY TEST (TYPE A)**

Check for continuity between the terminals.

1. There should be continuity between the No.30 and No.87 terminals when power and ground are connected to the No.85 and No.86 terminals.
2. There should be no continuity between the No.30 and No.87 terminals when power is disconnected.

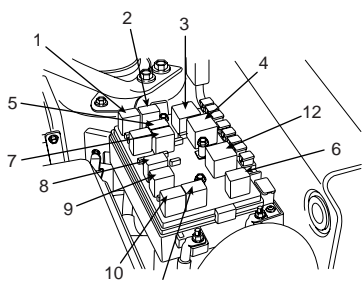

- |                          |                            |
|--------------------------|----------------------------|
| 1. A/T relay             | 7. Windshield deicer relay |
| 2. Air-conditioner relay | 8. Front fog lamp relay    |
| 3. Main relay            | 9. Head lamp relay(low)    |
| 4. Start relay           | 10. Head lamp relay(Hige)  |
| 5. Fuel pump relay       | 11. Horn relay             |
| 6. Wiper relay           | 12. Cooling fan #1 relay   |

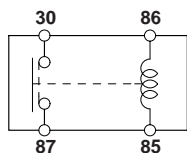
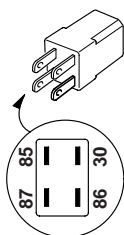

LTIF221A

Terminal	30	87	85	86
Power				
Disconnected			○ — ○	
Connected	○ — ○		⊖ — ⊕	

LTIF221B

**POWER RELAY TEST (TYPE B)**

Check for continuity between the terminals.

1. There should be continuity between the No.30 and No.87 terminals when power and ground are connected to the No.85 and No.86 terminals.
2. There should be no continuity between the No.30 and No.87A terminals when power is disconnected.

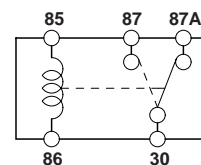
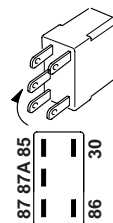
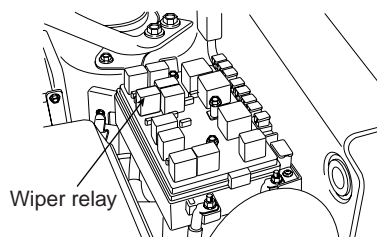

LTIF221C

Terminal	85	86	30	87	87A
Power					
Disconnected			○ — ○		
Connected	⊖ — ⊕		○ — ○		

LTIF221D

**FUSE INSPECTION**

1. Be sure there is no play in the fuse holders, and that the fuses are held securely.
2. Are the fuse capacities for each circuit correct?
3. Are there any blown fuses?  
If a fuse is to be replaced, be sure to use a new fuse of the same capacity. Always determine why the fuse blew first and completely eliminate the problem before installing a new fuse.

# RELAY BOX (PASSENGER COMPARTMENT)

## COMPONENTS E395A08F

< FRONT >

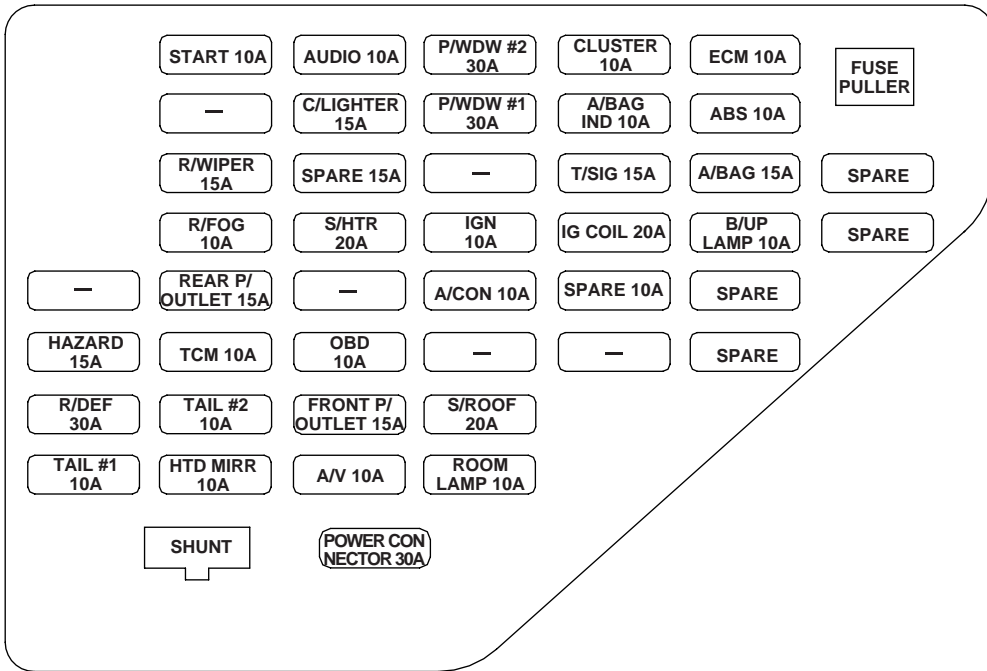

< REAR >

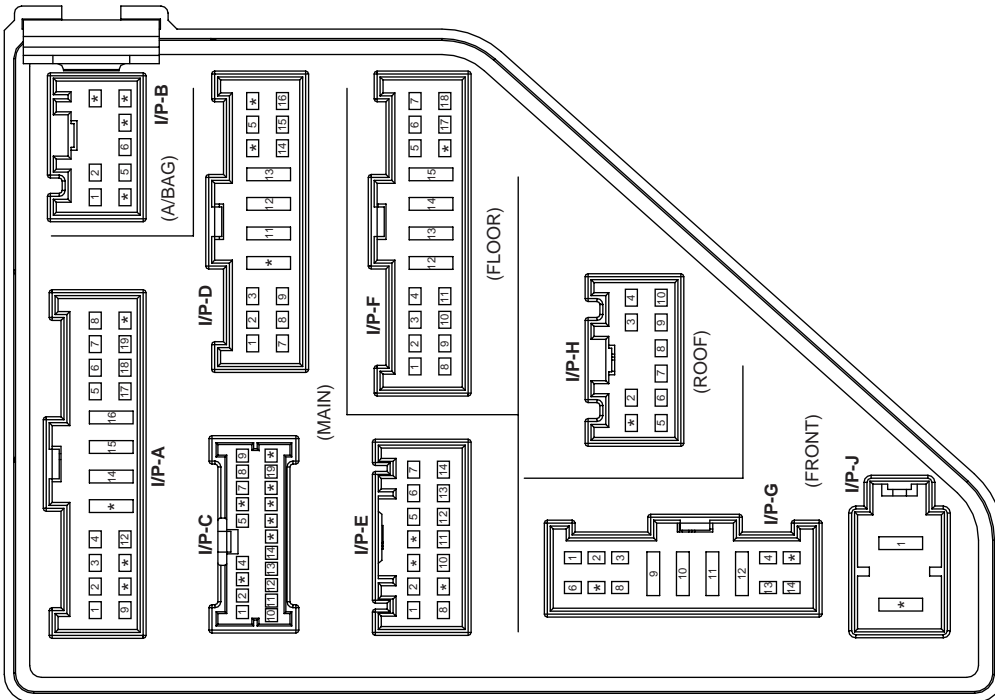

※ USE THE DESIGNATED FUSE ONLY

FUSE	(A)	Circuit Protected
TAIL #1	10A	Rear Combi Lamp RH, Head Lamp RH, F/FOG Relay, DRL Control Module, Illuminations
R/DEF	30A	Rear Defogger Relay, Contact
HAZARD	15A	Hazard Relay, Hazard Switch, ETACM, Instrument Cluster Multifunction Switch, Rear Combi Lamp LH/RH, Head Lamp LH/RH, Side Repeater Lamp LH/RH,
HTD MIRR	15A	Power Outside Mirror Motor LH/RH, A/C Control Module
TAIL #2	10A	Head Lamp LH, Rear Combi Lamp LH, License Lamp LH/RH
TCM	10A	TCM, Immobilizer Control Module
REAR P/OUTLET	15A	Rear Power Outlet
R/FOG	10A	R/FOG Relay
R/WIPER	15A	Instrument Cluster, ETACM, Luggage Lamp, Cargo Lamp, Tailgate Switch, Rear Window Switch, Rear Wiper Relay, Multifunction Switch, Rear Defogger Relay
START	10A	Burglar Alarm Relay, Cruise Control Module, Start Relay Transaxle Range Switch
A/V	10A	Audio
FRONT P/OUTLET	15A	Front Power Outlet
OBD	10A	Data Link Connector, Multipurpose Check Connector
S/HTR	20A	Seat Warmer Switch LH/RH
C/LIGHTER	15A	Cigarette Lighter
AUDIO	10A	Power Outside Mirror Switch, Digital Clock, ETACM Audio
ROOM LAMP	10A	Key Remind Switch, Instrument Cluster, ETACM, Room Lamp A/C Control Module, Digital Clock, Luggage Lamp, Front Door Lamp LH/RH, Map Lamp, Cargo Lamp, Sunroof Switch
S/ROOF	20A	Door Lock / Unlock Relay, Sunroof Controller
A/CON	10A	A/C Control Module, ETACM, Blower Relay, Sunroof Controller Electronic Chrome Mirror
IGN	10A	Head Lamp Relay, AQS Sensor, DRL Control Module, Fuel Filter Heater Relay
P/WDW #1	30A	Front Power Window Switch LH Rear Power Window Switch LH
P/WDW #2	30A	Front Power Window Switch LH/RH Rear Power Window Switch RH
IG COIL	20A	Ignition Coil
T/SIG	15A	Hazard Switch, Auto Light & Photo Sensor
A/BAG IND	10A	Instrument Cluster
CLUSTER	10A	Instrument Cluster, ETACM, Immobilizer Control Module Pre-excitation Resistor, Alternator, DRL Control Module
B/UP LAMP	10A	Back-up Lamp Switch, Transaxle Range Switch
A/BAG	10A	SRS Control Module
ABS	10A	ABS Control Module, ESP Control Module, G-sensor, TCS Switch, ESP Switch, Steering Angle Sensor
ECM	10A	Immobilizer Control Module, Vehicle Speed Sensor, ECM, TCM Pulse Generator 'A/B', Fuel Filter Warning Switch, Cruise Control Module, Mass Air Flow Sensor, 4WD ECM, Stop Lamp Switch, Multifunction Switch

✘ USE THE DESIGNATED FUSE ONLY

**FUSE INSPECTION** E23CEF2E

1. Be sure there is no play in the fuse holders, and that the fuses are held securely.
2. Are the fuse capacities for each circuit correct?
3. Are there any blown fuses?  
If a fuse is to be replaced, be sure to use a new fuse of the same capacity. Always determine why the fuse blew first and completely eliminate the problem before installing a new fuse.

**ICM (INTEGRATED CIRCUIT MODULE)**

**RELAY** EE80A696

The ICM is united with many kinds of relay and installed at the below the relay box(passenger compartment).

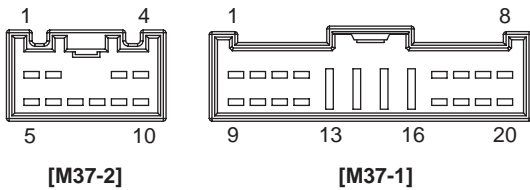
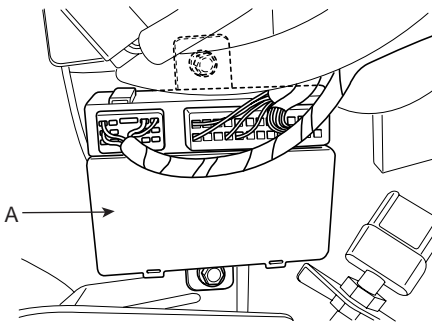

ATIE220F

**ICM (INTEGRATED CIRCUIT MODULE)**

**RELAY TEST** EDD1583D

**DOOR LOCK RELAY**

Check for continuity between the terminals.

1. There should be continuity between the No.17 and No.19 terminals when power and ground are connected to the No.17 and No.20 in the M37-1 terminals.
2. There should be no continuity between the No.17 and No.19 terminals when power is disconnected.

**DOOR UNLOCK RELAY**

Check for continuity between the terminals.

1. There should be continuity between the No.17 and No.18 terminals when power and ground are connected to the No.17 and No.5 in the M37-1 terminal.
2. There should be no continuity between the No.7 and No.18 terminals when power is disconnected.

**REAR FOG RELAY**

1. There should be continuity between the No.9 in the M37-1 and No.4 in the M37-2 terminals when power and ground are connected to the No.1 in the M37-1 and No.3 in the M37-2 terminals.
2. There should be continuity between the No.9 in the M37-1 and No.10 in the M37-2 terminals when power and ground are disconnected to the No.1 in the M37-1 and No.3 in the M37-2 terminals.

**BURGLAR ALARM**

1. There should be continuity between the No.7 and No.9 terminals when power and ground are connected to the No.7 and No.8 in the M37-2 terminals.
2. There should be no continuity between the No.7 and No.9 terminals when power is disconnected.

**BURGLAR ALARM HORN**

1. There should be continuity between the No.6 and No.5 terminals when power and ground are connected to the No.6 and No.1 in the M37-2 terminals.
2. There should be no continuity between the No.6 and No.5 terminals when power is disconnected.

# INDICATORS AND GAUGES

## COMPONENTS E4735D61

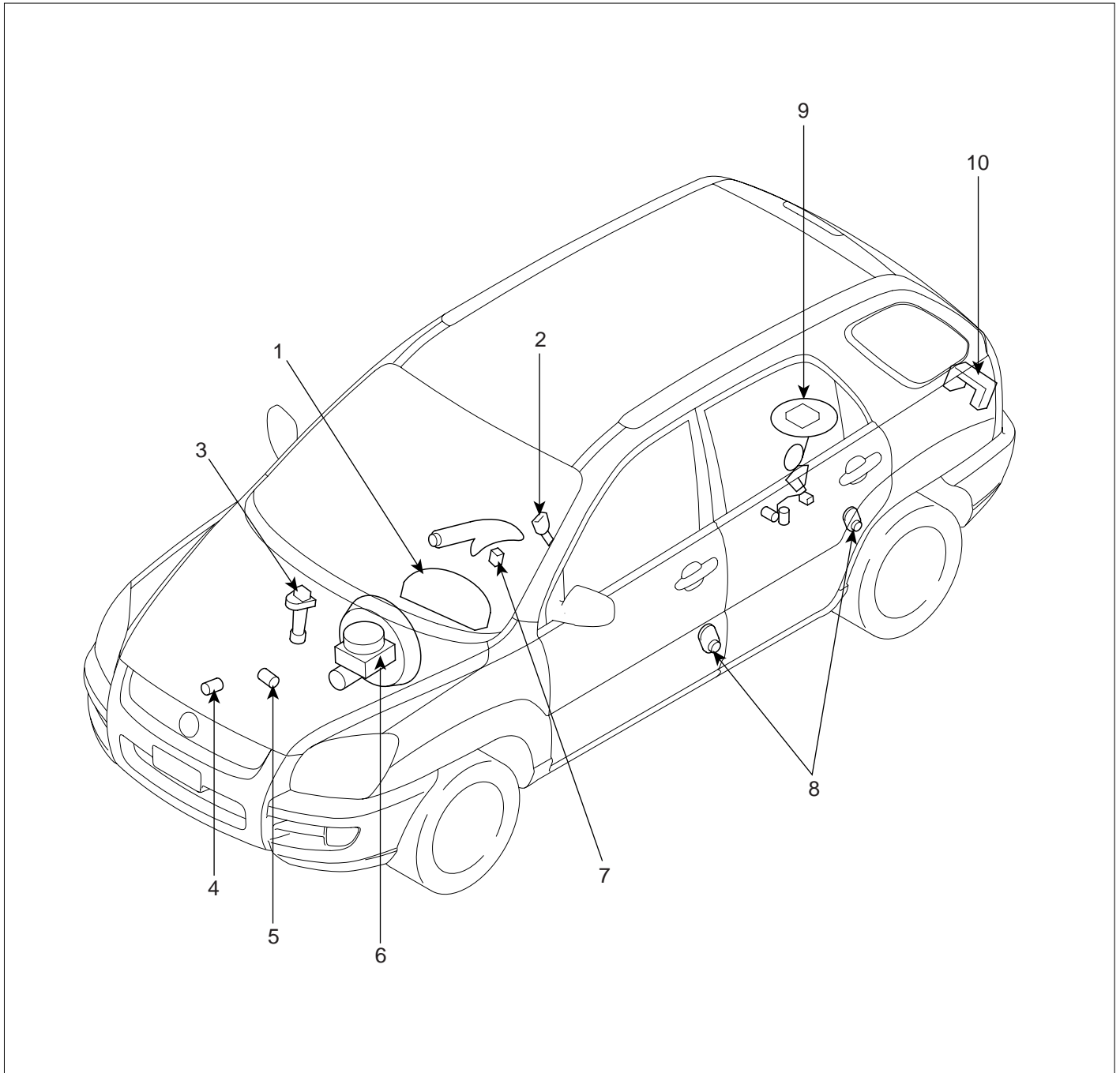

- |                                      |                                     |
|--------------------------------------|-------------------------------------|
| 1. Cluster assembly                  | 6. Brake fluid level warning switch |
| 2. Seat belt switch                  | 7. Parking brake switch             |
| 3. Vehicle speed sensor              | 8. Door switch                      |
| 4. Engine coolant temperature sender | 9. Fuel gauge sender                |
| 5. Oil pressure switch               | 10. Tailgate switch                 |

LTIF260A

# INSTRUMENT CLUSTER

## COMPONENTS E87CAD90

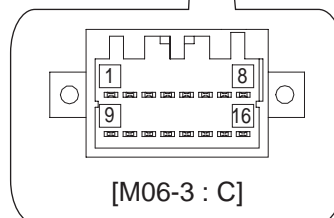
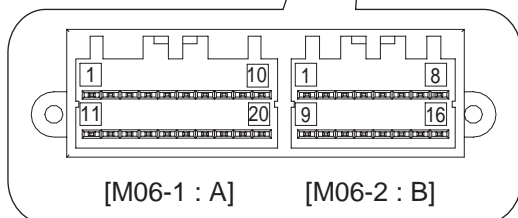
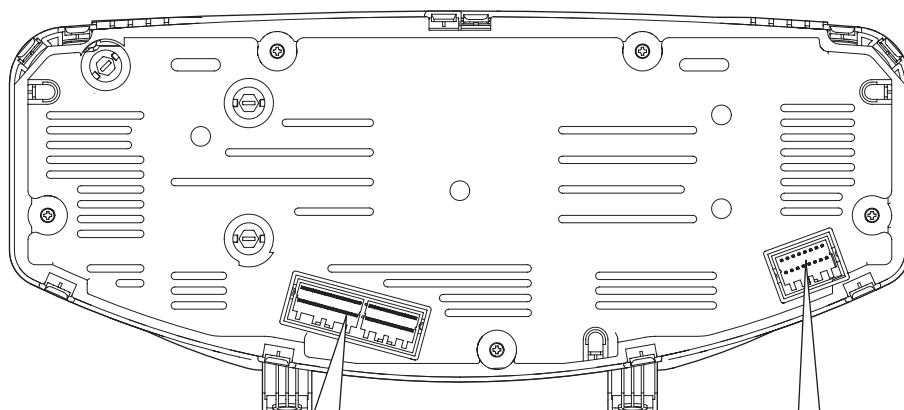
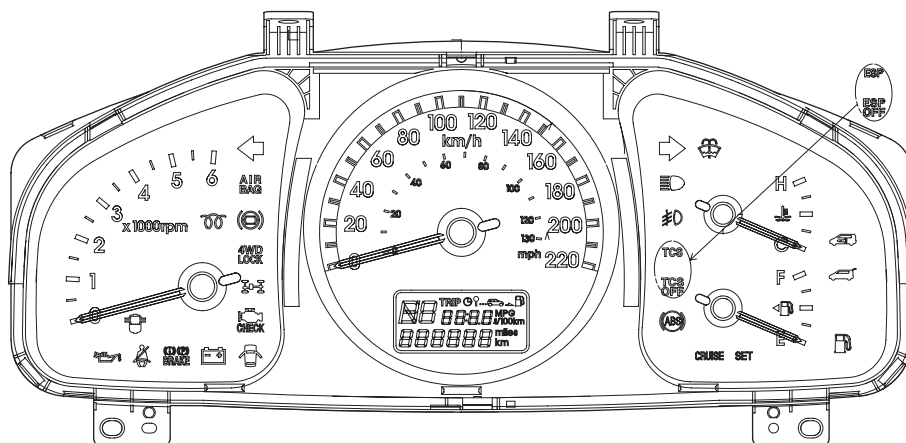

CIRCUIT DIAGRAM E24E7D4D

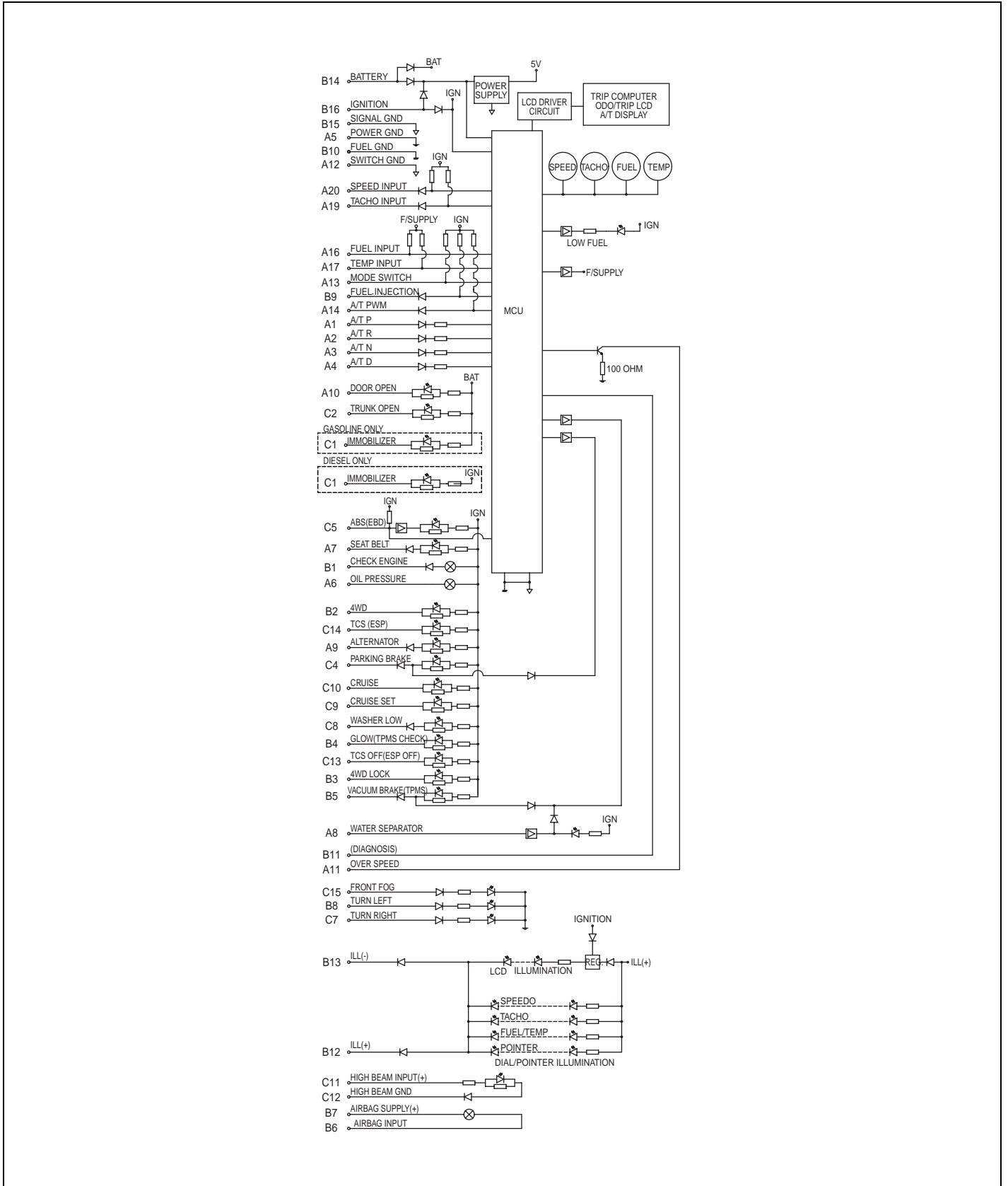

REPLACEMENT E3593F23

1. Disconnect the negative (-) battery terminal.
2. Remove the cluster facia panel (A) after removing 2 screws.
3. Remove the trip switch connector.

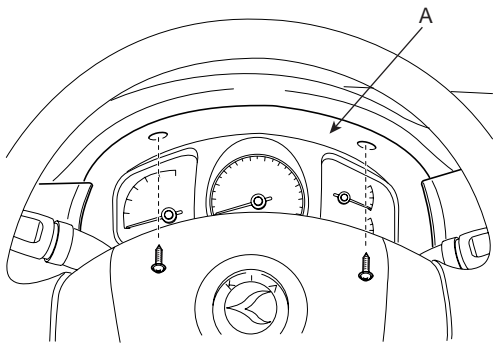

ATIE261A

4. Remove the cluster (A) from the housing after removing 4 screws.

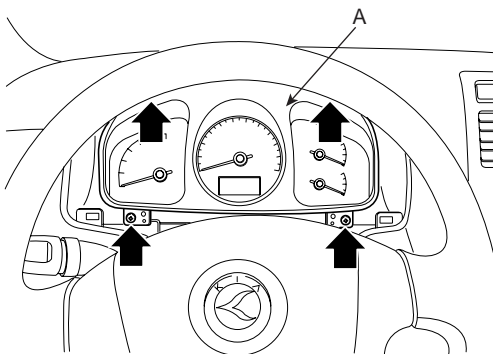

ATIE261B

5. Remove the cluster connector (A) and the cluster (B).

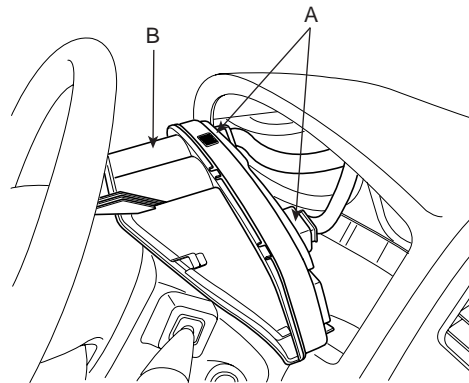

ATIE261C

6. Installation is the reverse of removal.

**INSPECTION** E3EEFF3C

**SPEEDOMETER**

1. Adjust the pressure of the tires to the specified level.
2. Drive the vehicle onto a speedometer tester. Use wheel chocks as appropriate.
3. Check if the speedometer indicator range is within the standard values.



**Do not operate the clutch suddenly or increase/decrease speed rapidly while testing.**



*Tire wear and tire over or under inflation will increase the indication error.*

Velocity (km/h)	20	40	60	80	100
Tolerance (km/h)	+4.7 +0.7	+6.5 +2.5	+9.0 +4	+11.6 +6.0	+14 +8.4
Velocity (km/h)	120	140	160	180	200
Tolerance (km/h)	+16 +10	+18 +12	+21 +14.4	+23 +16.4	+23 +16

Velocity (MPH)	10	20	40	60
Tolerance (MPH)	+3.5 +0.5	+4.0 +1.0	+6.0 +2.4	+8.0 +4.0
Velocity (MPH)	80	100	120	
Tolerance (MPH)	+10.0 +5.4	+12.0 +7.0	+14.0 +9.0	

**VEHICLE SPEED SENSOR**

1. Connect the positive (+) lead from battery to terminal 3 and negative (-) lead to terminal 1.
2. Connect the positive (+) lead from tester to terminal 2 and the negative (-) lead to terminal 1.
3. Rotate the shaft.
4. Check that there is voltage change from approx. 0V to 11V or more between terminals 1 and 2.
5. The voltage change should be 4 times for every revolution of the speed sensor shaft. If operation is not as specified, replace the sensor.

**TACHOMETER**

1. Connect the scan tool to the diagnostic link connector or install a tachometer.
2. With the engine started, compare the readings of the tester with that of the tachometer. Replace the tachometer if the tolerance is exceeded.



- **Reversing the connections of the tachometer will damage the transistor and diodes inside.**
- **When removing or installing the tachometer, be careful not to drop it or subject it to severe shock.**

Revolution(rpm)	1,000	2,000	3,000	4,000
Tolerance(rpm)	±100	±125	±150	±150
Revolution(rpm)	5,000	6,000	7,000	
Tolerance(rpm)	±150	±180	±210	

**FUEL GAUGE**

1. Disconnect the fuel sender connector from the fuel sender.
2. Connect a 3.4 wattages, 12V test bulb to terminals 2 and 3 on the wire harness side connector.
3. Turn the ignition switch to the ON, and then check that the bulb lights up and the fuel gauge needle moves to full.

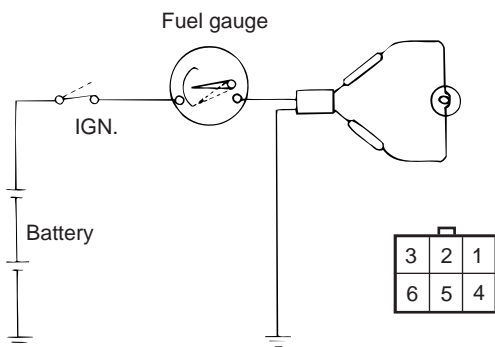

LTIF986A

**FUEL SENDER**

1. Using an ohmmeter, measure the resistance between terminals 5 and 6 at each float level.

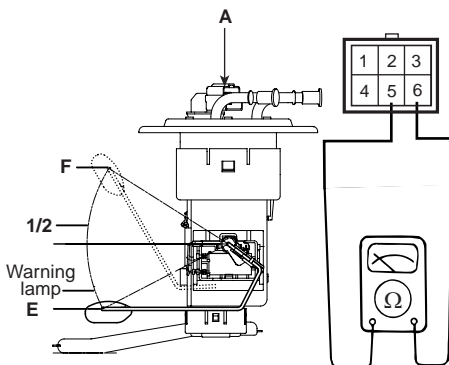

LTIF987A

2. Also check that the resistance changes smoothly when the float is moved from "E" to "F".
3. If the height resistance is unsatisfied, replace the fuel sender as an assembly.

**CAUTION**

After completing this test, wipe the sender dry and reinstall it in the fuel tank.

**SUCTION FUEL GAUGE SENDER**

1. Using an ohmmeter, measure the resistance between terminals 1 and 2 of SUB sender connector (A) at each float level.

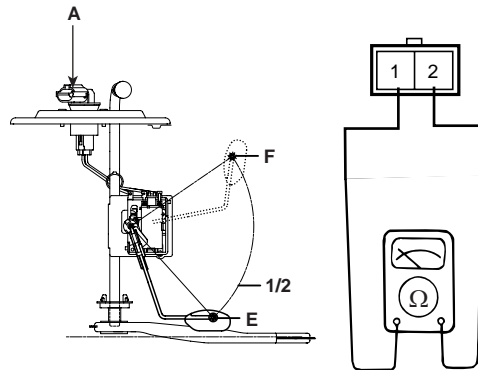

ATIE262C

2. Also check that the resistance changes smoothly when the float is moved from "E" to "F".

Position	Resistance( )
Sender (E)	95.2 ± 1
1/2	90.2 ± 1
Sender (F)	3.8 ± 1

3. If the height resistance is unsatisfied, replace the fuel sender as an assembly.

**ENGINE COOLANT TEMPERATURE GAUGE**

1. Disconnect the wiring connector (A) from the engine coolant temperature sender in the engine compartment.
2. Turn the ignition switch ON. Check that the gauge needle indicates cool. Turn the ignition switch OFF.
3. Connect a 12V, 3.4 wattages test bulb between the harness side connector and ground.
4. Turn the ignition switch ON.

5. Verify that the test bulb flashes and that the indicator moves to HOT. If operation is not specified, replace the engine coolant temperature gauge. Then recheck the system.

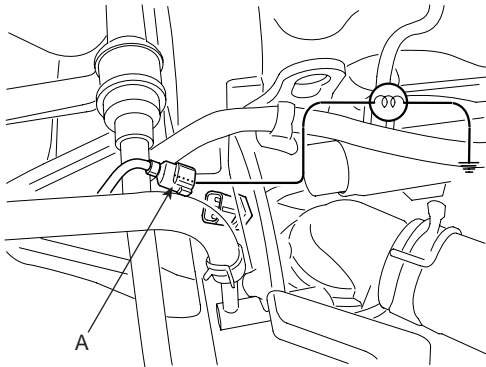

ATIE262D

**ENGINE COOLANT TEMPERATURE SENDER**

1. Using an ohmmeter, measure the resistance between the terminal 2 of sender connector and ground.
2. If the resistance value is not as shown in the table, replace the temperature sender.

Temperature (°C)	49	71	Engine
Gauge angle (°)	-23	-1 ± 2	-
Resistance ( )	195	86.5	Diesel
	128	53.8	Gasoline
Temperature (°C)	110	127.4	Engine
Gauge angle (°)	1 ± 2	23 ± 5	-
Resistance ( )	24	16.1	Diesel
	16.1	14.1	Gasoline

**OIL PRESSURE SWITCH**

1. Check that there is continuity between the oil pressure switch terminal (A) and ground with the engine off.
2. Check that there is no continuity between the terminal and ground with the engine running.
3. If operation is not as specified, replace the switch.

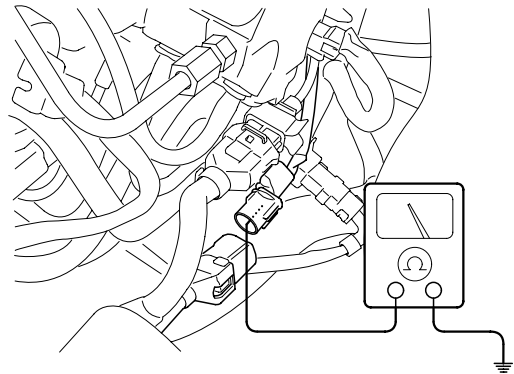

ATIE262E

**OIL PRESSURE WARNING LAMP**

1. Disconnect the connector from the warning switch and ground the terminal on the wire harness side connector.
2. Turn the ignition switch ON. Check that the warning lamp lights up. If the warning lamp doesn't light, test the bulb or inspect the wire harness.

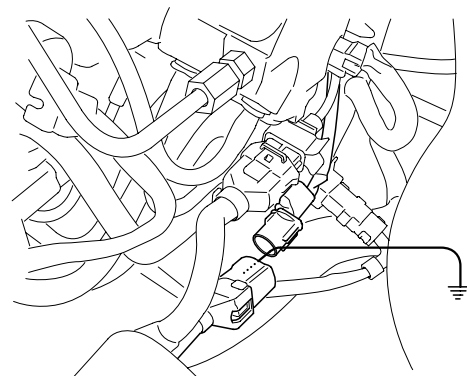

ATIE262F

**BRAKE FLUID LEVEL WARNING SWITCH**

1. Remove the connector from the switch located at the brake fluid reservoir.
2. Verify that continuity exists between switch terminals 1 and 2 while pressing the switch (float) down with a rod.

**BRAKE FLUID LEVEL WARNING LAMP**

1. Start the engine.
2. Release the parking brake.
3. Remove the connector from the brake fluid level warning switch.
4. Ground the connector at the harness side.
5. Verify that the warning lamp lights.

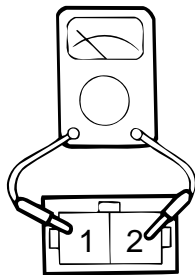
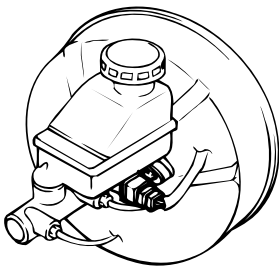

V5BE060M

**PARKING BRAKE SWITCH**

The parking brake switch (A) is a pulling type. It is located under the parking brake lever. To adjust, move the switch mount up and down with the parking brake lever released all the way.

1. Check that there is continuity between the terminal and switch body with the switch ON (Lever is pulled).
2. Check that there is no continuity between the terminal and switch body with the switch OFF (Lever is released).  
If continuity is not as specified, replace the switch or inspect its ground connection.

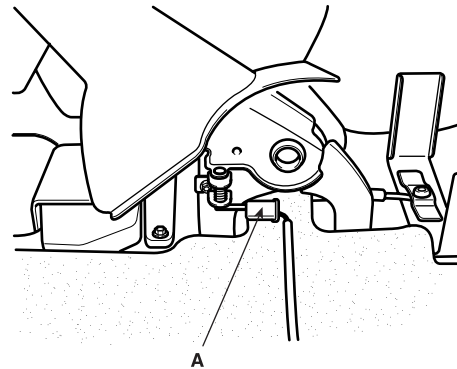

AJGE038B

**DOOR SWITCH**

Remove the door switch and check for continuity between the terminals.

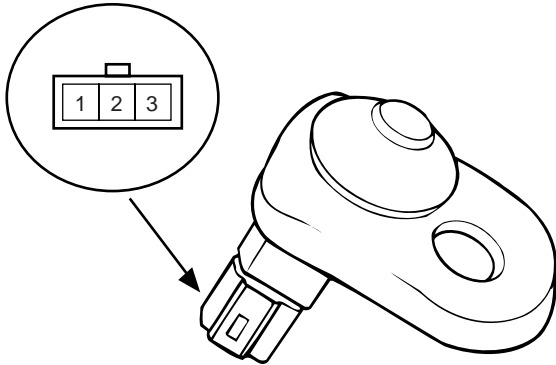

KTKD020A

Terminal	1	2	Ground
Free(Door open)	○	○	○
Push(Door close)			

ETKE021A

**SEAT BELT SWITCH**

1. Remove the connector from the switch.
2. Check for continuity between terminals.

Seat belt condition	Continuity
Fastened	Non-conductive ( )
Not fastened	Conductive ( )

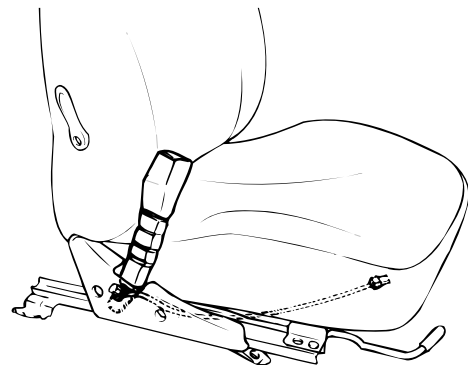

V5BE060Q

**SEAT BELT WARNING LAMP**

With the ignition switch turned ON, verify that the lamp glows.

Seat belt condition	Warning lamp
Fastened	OFF
Not fastened	ON

# POWER DOOR LOCKS

## COMPONENTS E2F74DF7

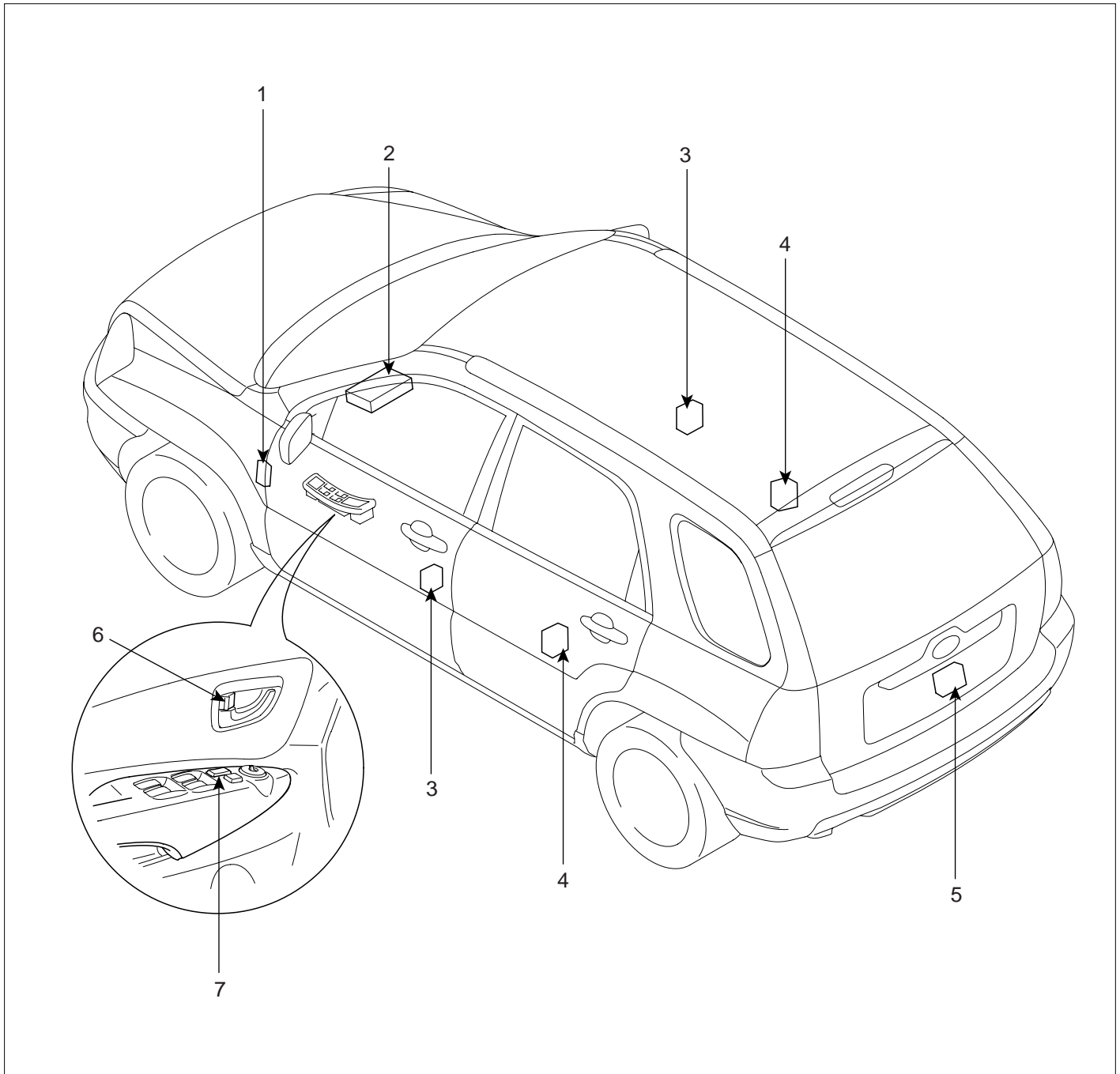

- 1. ICM relay box
- 2. ETACS module
- 3. Front door lock actuator & switch
- 4. Rear door lock actuator & switch
- 5. Tailgate lock actuator & switch
- 6. Door lock knob
- 7. Door lock switch

LTIF280A

**POWER DOOR LOCKS**

**POWER DOOR LOCK ACTUATORS**

**INSPECTION** EBAEA304

**FRONT DOOR LOCK ACTUATOR INSPECTION**

1. Remove the front door trim panel. (Refer to the BD group-front door)
2. Disconnect the 6P connector from the actuator.

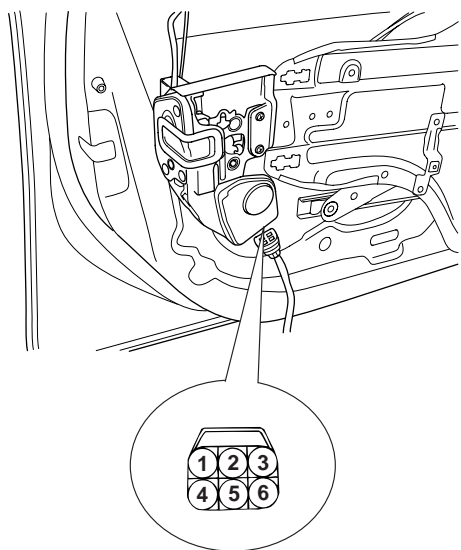

KTKD047A

3. Check actuator operation by connecting power and ground according to the table. To prevent damage to the actuator, apply battery voltage only momentarily.

Position		Terminal	
		4	6
Front left	Lock	⊖	⊕
	Unlock	⊕	⊖
Front right	Lock	⊕	⊖
	Unlock	⊖	⊕

LTIF014A

**REAR DOOR LOCK ACTUATOR INSPECTION**

1. Remove the rear door trim panel. (see BD group-rear door)
2. Disconnect the 6P connector from the actuator.

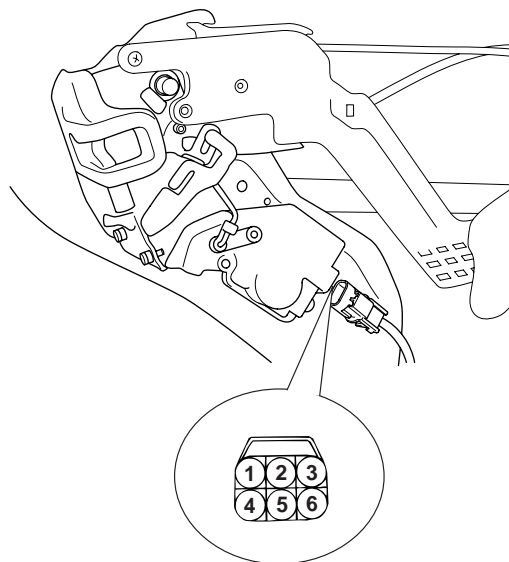

KTKD048A

3. Check actuator operation by connecting power and ground according to the table. To prevent damage to the actuator, apply battery voltage only momentarily.

Position		Terminal	
		2	3
Rear left	Lock	⊕	⊖
	Unlock	⊖	⊕
Rear right	Lock	⊖	⊕
	Unlock	⊕	⊖

ETQF275B

**TAILGATE LOCK ACTUATOR INSPECTION**

1. Remove the tailgate trim panel. (see BD group-tail-gate)
2. Disconnect the 6P connector from the actuator.

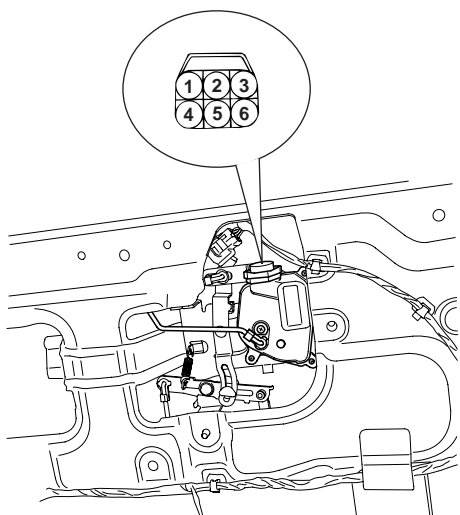

KTQE280F

**FRONT DOOR LOCK SWITCH INSPECTION**

1. Remove the front door trim panel. (Refer to the BD group - front door)
2. Disconnect the 6P connector from the actuator.

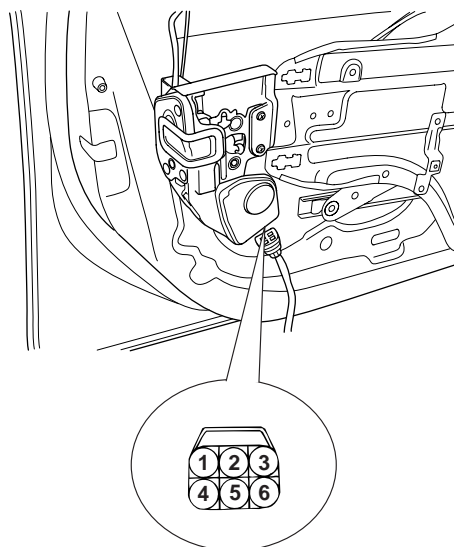

KTKD047A

3. Check actuator operation by connecting power and ground according to the table. To prevent damage to the actuator, apply battery voltage only momentarily.

Terminal	1	2
Lock	⊕	⊖
Unlock	⊖	⊕

LTIF270B

3. Check for continuity between the terminals in each switch position according to the table.

		Terminal		
		1	2	3
Front left	Lock	○	—	○
	Unlock	○	○	
Front right	Lock	○	—	○
	Unlock		○	○

ETQF281A

**POWER DOOR LOCKS**

**REAR DOOR LOCK SWITCH INSPECTION**

1. Remove the rear door trim panel. (Refer to the BD group - rear door)
2. Disconnect the 6P connector from the actuator.

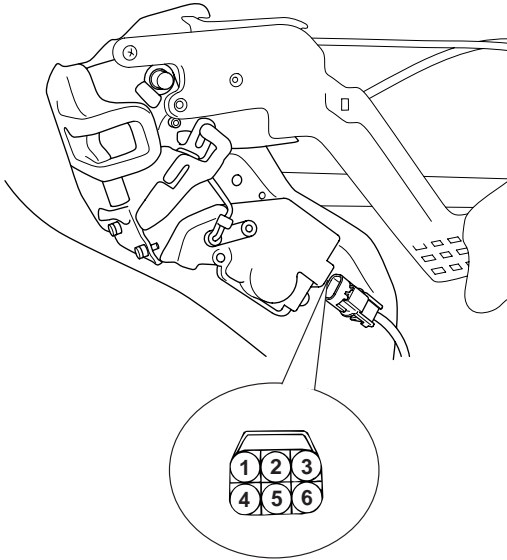

KTKD048A

3. Check for continuity between the terminals in each switch position according to the table.

Position		Terminal		
		4	5	6
Rear left	Lock		○ — ○	
	Unlock	○ — ○		
Rear right	Lock	○ — ○		
	Unlock		○ — ○	

ETQF280B

**TAILGATE LOCK SWITCH INSPECTION**

1. Remove the tailgate trim panel. (see BD group - tail-gate)
2. Disconnect the 6P connector from the actuator.

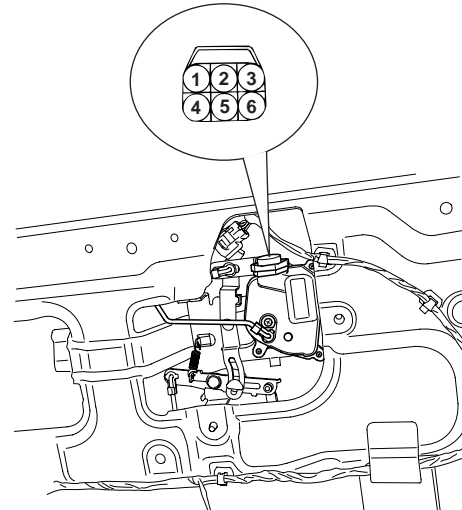

KTQE280F

3. Check for continuity between the terminals in each switch position according to the table.

Position		Terminal		
		4	5	6
Lock			○ — ○	
Unlock		○ — ○		

LTIF262M

## POWER DOOR LOCK RELAY

### INSPECTION EDF38CBC

1. Remove the negative (-) battery terminal.
2. Remove the driver side crash pad lower panel.
3. Remove the ICM relay box (A) after loosening 2 mounting nuts and removing 3 connectors under the junction box (Passenger compartment).

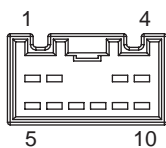
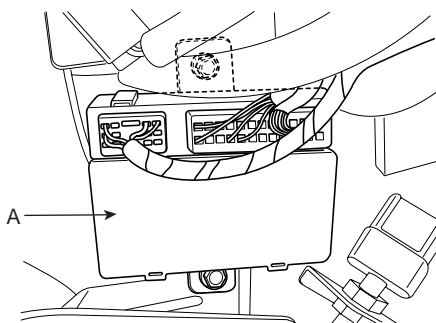

[M37-2]

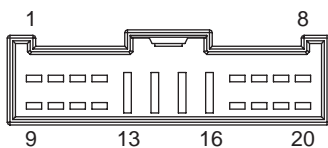

[M37-1]

ATIE220F

4. Check for continuity between the terminals.

### DOOR LOCK

Check for continuity between the terminals.

1. There should be continuity between the No.17 and No.19 terminals when power and ground are connected to the No.17 and No.20 in the M37-1 terminals.
2. There should be no continuity between the No.17 and No.19 terminals when power is disconnected.

### DOOR UNLOCK

1. There should be continuity between the No.17 and No.18 terminals when power and ground are connected to the No.17 and No.5 in the M37-1 terminals.
2. There should be no continuity between the No.17 and No.18 terminals when power is disconnected.

**POWER DOOR LOCK SWITCH**

**INSPECTION** EB2C487C

**DRIVER'S DOOR LOCK SWITCH INSPECTION**

1. Remove the negative (-) battery terminal.
2. Remove the power window switch module by pressing fixing clip part (B) with scraper (A).

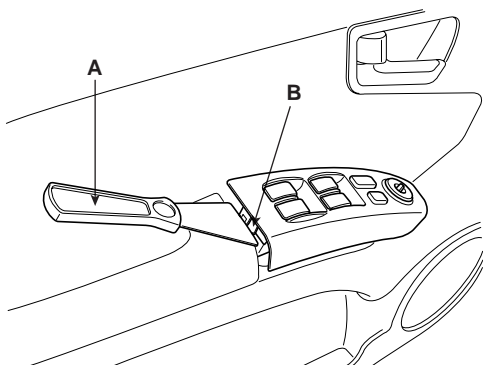

ATIE284A

3. Check for continuity between the terminals in each switch position according to the table.

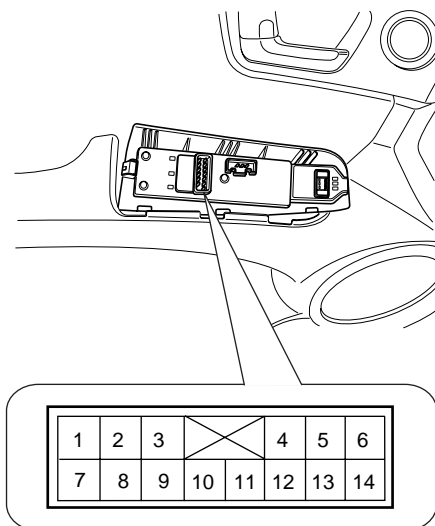

ATIE284B

Terminal Position	4	10	11
Lock		○ — ○	○ — ○
Unlock	○ — ○		

LTIF284C

**ASSIST DOOR LOCK SWITCH INSPECTION**

1. Remove the negative (-) battery terminal.
2. Remove the power window switch module by pressing fixing clip part (B) with scraper (A).

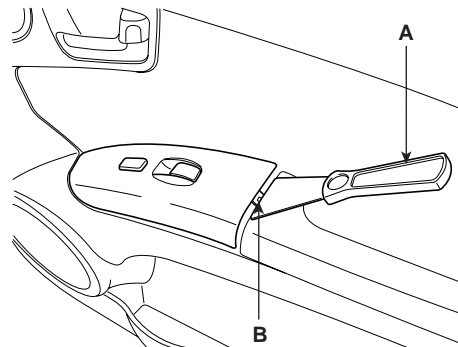

ATIE284D

3. Check for continuity between the terminals in each switch position according to the table.

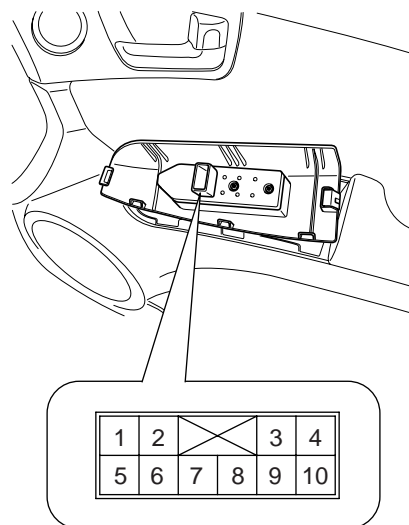

ATIE284E

Terminal Position	3	4	7
Lock		○ — ○	○ — ○
Unlock	○ — ○		○ — ○

LTIF934A

## POWER DOOR MIRRORS

### COMPONENTS E8C6B936

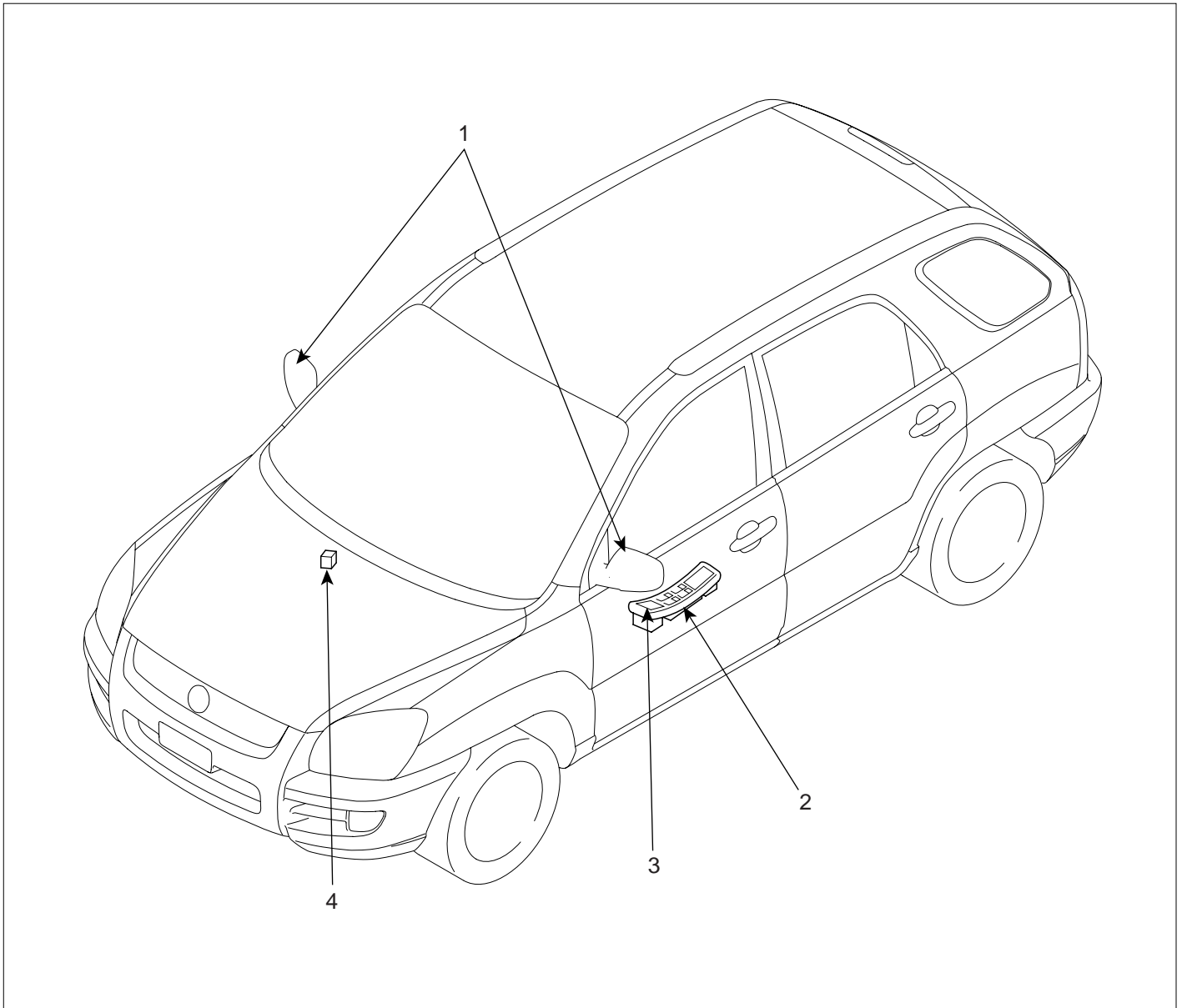

- 1. Power door mirror
- 2. Power door mirror switch

- 3. Mirror folding switch
- 4. Mirror folding relay

LTIF300A

POWER DOOR MIRROR SWITCH

CIRCUIT DIAGRAM E075CB5D

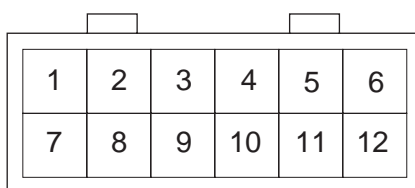
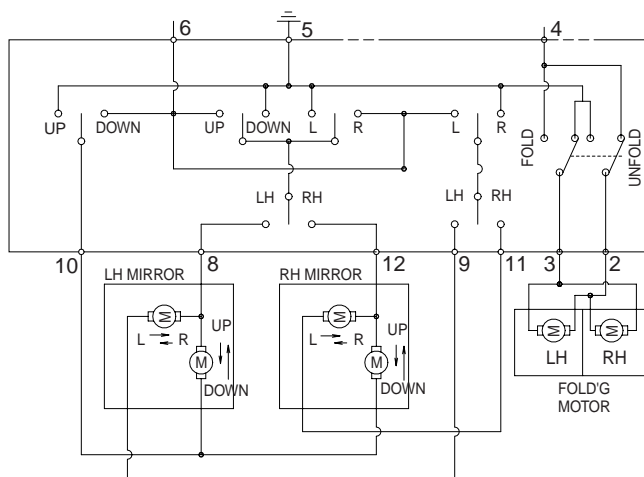
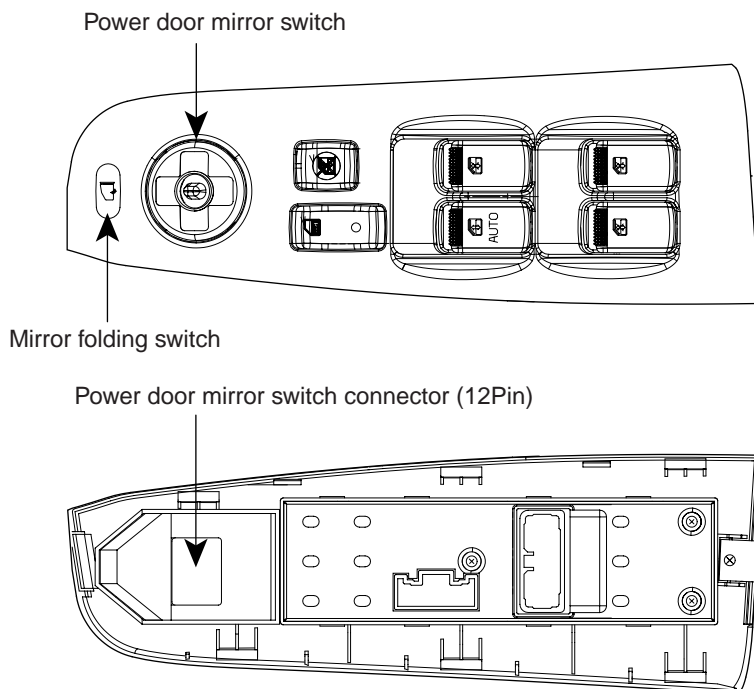

[Power door mirror switch connector]

**INSPECTION** E3C8872E

1. Remove the negative (-) battery terminal.
2. Remove the power window switch module by pressing fixing clip part (B) with scraper (A).

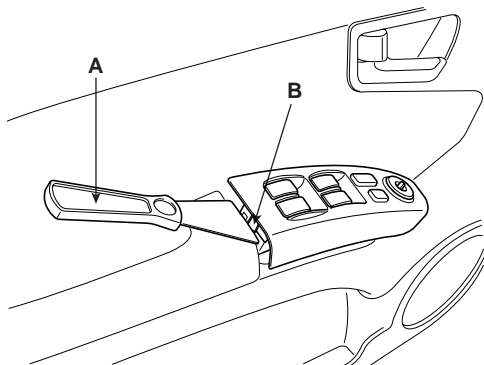

ATIE284A

3. Check for continuity between the terminals in each switch position according to the table.

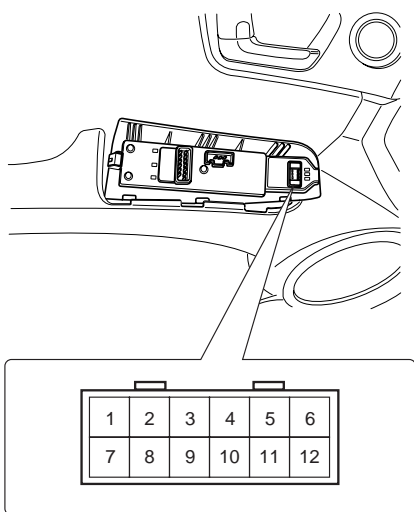

ATIE301B

4. Check for continuity between the terminals in each switch position according to the table.

Class	Terminal Direction	5	6	8	9	10	11	12
		Left	UP	○	○	○	○	○
DOWN	○		○	○	○	○		
OFF	○			○	○	○		
LEFT	○		○	○	○			
RIGHT	○		○	○	○			
Right	UP	○	○			○	○	○
	DOWN	○	○			○	○	○
	OFF	○				○	○	○
	LEFT	○	○			○	○	○
	RIGHT	○	○			○	○	○

<MIRROR FOLDING SWITCH>

LTIF301C

**MIRROR FOLDING SWITCH INSPECTION**

Terminal Position	2	3	4	5
ON(PUSH)	○	○	○	○
OFF(FREE)	○	○	○	○

LTIF301D

**POWER DOOR MIRROR ACTUATOR**

**INSPECTION** E700CF71

1. Disconnect the power door mirror connector from the harness.
2. Apply battery voltage to each terminal as shown in the table and verify that the mirror operates properly.

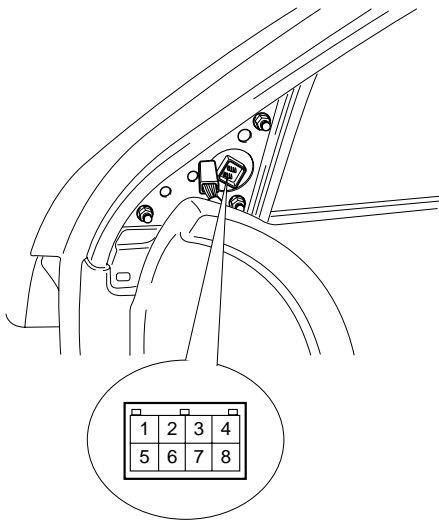

ATIE302B

Terminal Position	1	2	3
UP	+	+	-
DOWN	-	-	+
OFF	+	+	+
LEFT	-	+	-
RIGHT	+	-	+

ETQF195B

**MIRROR HEATER INSPECTION**

Terminal Position	7	8
Heater	○	○

ETQF195D

**MIRROR FOLDING INSPECTION**

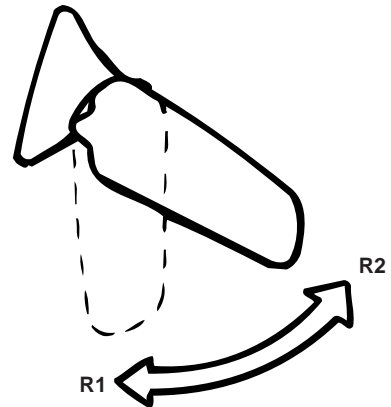

ETJA055B

Terminal Direction	5	6
R1	+	-
R2	-	+

ETQF055A

**MIRROR FOLDING RELAY INSPECTION**

1. Disconnect the negative (-) battery terminal.
2. Remove the center facia panel (C) after pulling it by using regular screw driver(-) at part (A). Take care of fixing clips (B).

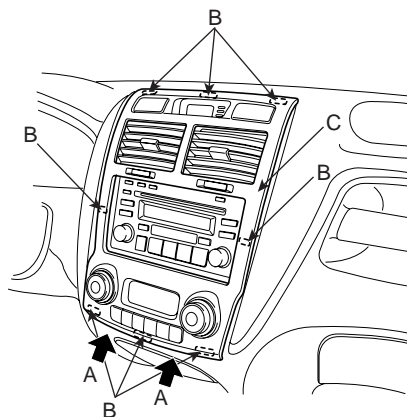

ATIE021A

3. Remove the connectors.
4. Remove the mounting screws then remove the audio unit assembly.

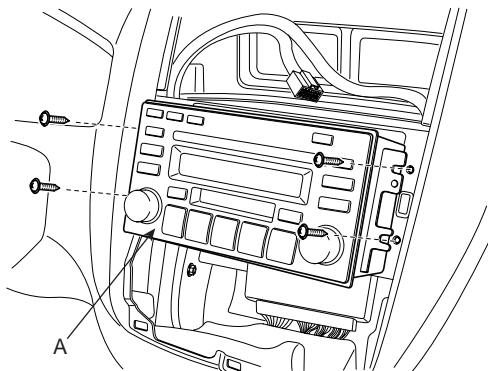

ATIE021E

5. Remove the mirror folding relay after loosening a nut from the cowl cross member bar.

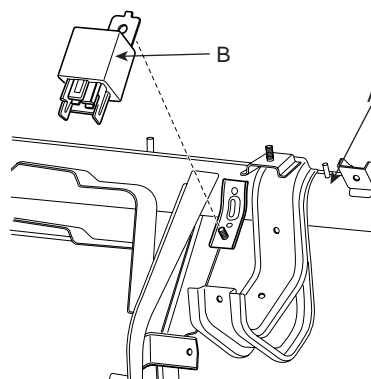

ATIE302F

6. There should be continuity between the No.1 and No.3 terminals when power and ground are connected to the No.2 and No.4 terminals.
7. There should be no continuity between the No.1 and No.3 terminals when power is disconnected.

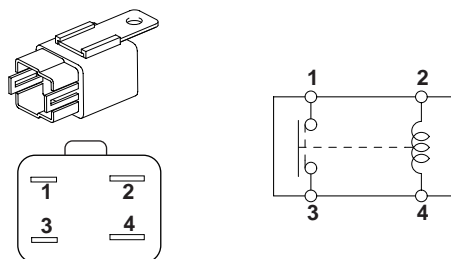

ATIE302G

Terminal Position	2	4	1	3
Disconnected	○ — ○			
Connected	⊖ — ⊕		○ — ○	

LTIF302H

# POWER WINDOWS

## COMPONENTS E18ECF7B

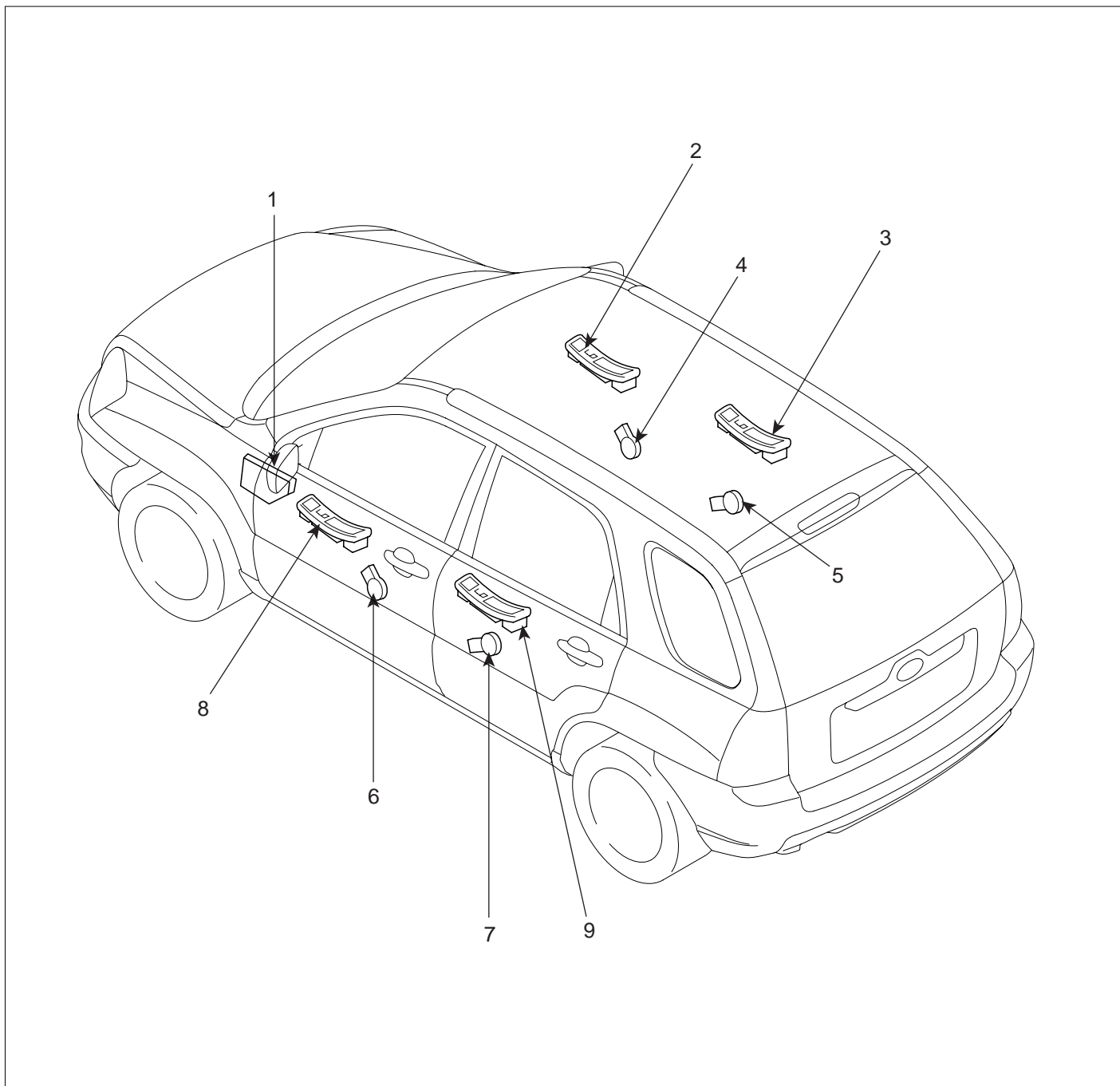

- 1. Passenger compartment junction box  
(Power window relay)
- 2. Assist window switch
- 3. Rear window switch
- 4. Front window motor

- 5. Rear window motor
- 6. Front window motor
- 7. Rear window motor
- 8. Driver window main switch
- 9. Rear window switch

LTIF320A

## POWER WINDOW MOTOR

### INSPECTION EB6CAD01

#### FRONT POWER WINDOW MOTOR INSPECTION

1. Remove the front door trim panel. (Refer to the BD group-front door)
2. Disconnect the 2P connector from the motor.

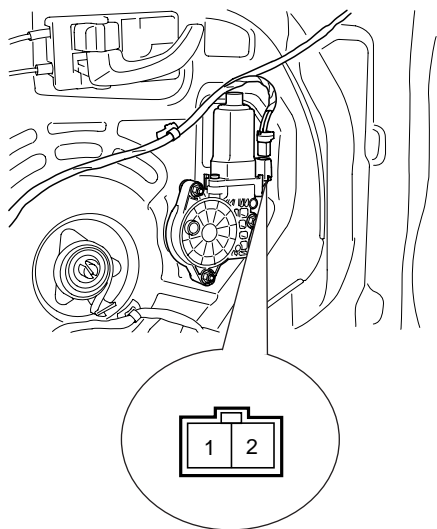

LTIF320B

3. Connect the motor terminals directly to battery voltage (12V) and check that the motor operates smoothly. Next, reverse the polarity and check that the motor operates smoothly in the reverse direction. If the operation is abnormal, replace the motor.

Position		Terminal		1	2
		UP	Clockwise		
LH	UP	Clockwise	⊖	⊕	
	DOWN	Counter-clockwise	⊕	⊖	
RH	DOWN	Clockwise	⊕	⊖	
	UP	Counter-clockwise	⊖	⊕	

ETQF057A

#### REAR POWER WINDOW MOTOR INSPECTION

1. Remove the rear door trim panel. (Refer to the BD group-rear door)
2. Disconnect the 2P connector from the motor.

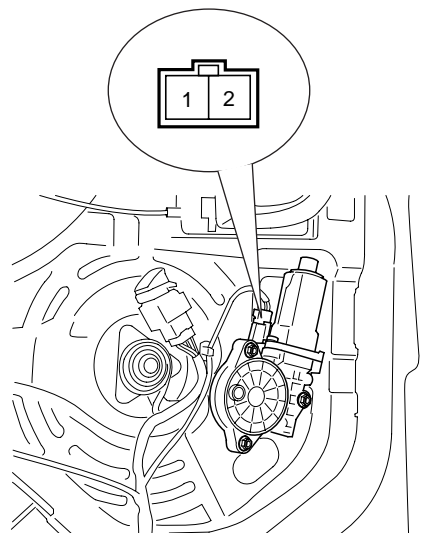

KTQE280B

3. Connect the motor terminals directly to battery voltage (12V) and check that the motor operates smoothly. Next, reverse the polarity and check that the motor operates smoothly in the reverse direction. If the operation is abnormal, replace the motor.

Position		Terminal		1	2
		UP	Clockwise		
LH	UP	Clockwise	⊖	⊕	
	DOWN	Counter-clockwise	⊕	⊖	
RH	DOWN	Clockwise	⊕	⊖	
	UP	Counter-clockwise	⊖	⊕	

ETQF057A

**POWER WINDOW RELAY**

**INSPECTION** EA616BAF

1. Remove the negative (-) battery terminal.
2. Remove the junction box.
3. Check for continuity between the terminals.
4. There should be continuity between the No.1 in the I/P-J terminal and No.12 or 13 in the I/P-F terminal when power and ground are connected to the No.1 in the I/P-J terminal and No.12 in the I/P-C terminal.
5. There should be no continuity between the No.1 in the I/P-J terminal and No.12 or 13 in the I/P-F terminal when power is disconnected.

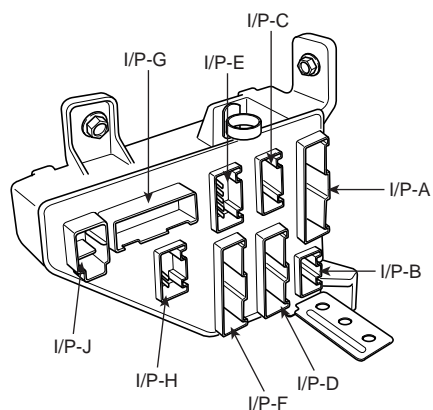

ATIE323A

Terminal Position	I/P-F (12 or 13)	I/P-J (1)	I/P-C (12)	I/P-J (1)
Disconnected			○ — ○	
Connected	○ — ○		⊖ — ⊕	

LTIF323B

**POWER WINDOW SWITCH**

**CIRCUIT DIAGRAM** E00BE3C4

[Power window main switch : Auto down type]

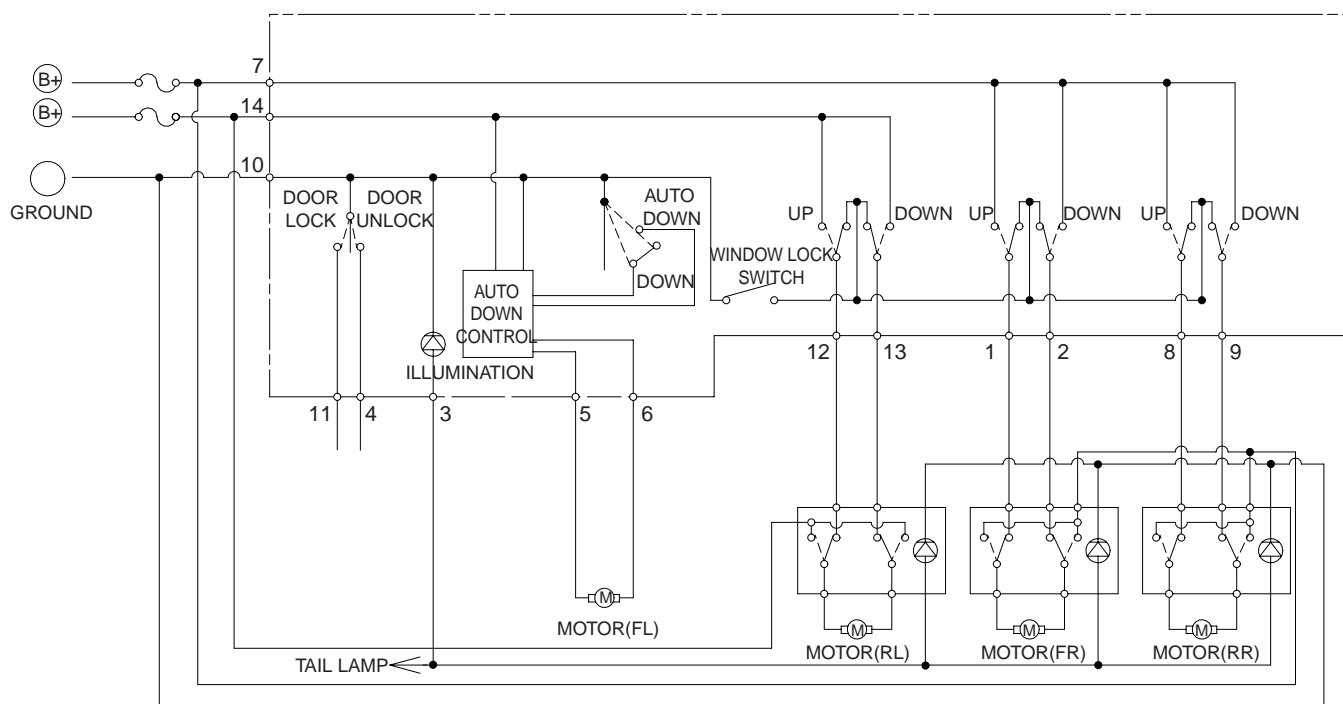
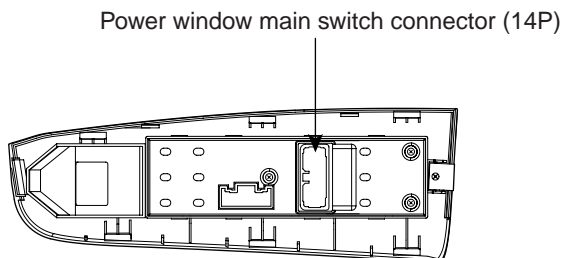
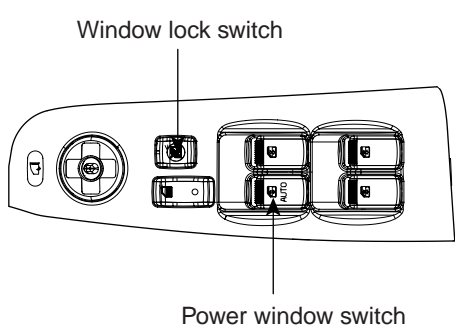

1	2	3	X	4	5	6	
7	8	9	10	11	12	13	14

(Power window main switch connector)

[ Power window sub-switch ]

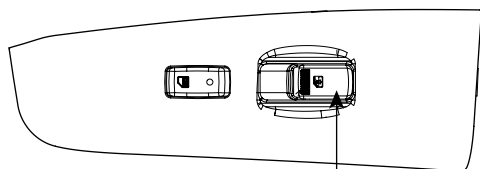

Power window switch

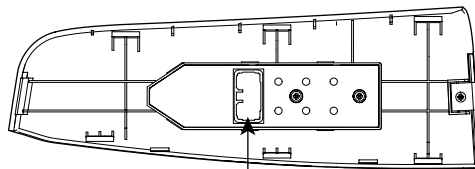

Power window sub-switch connector

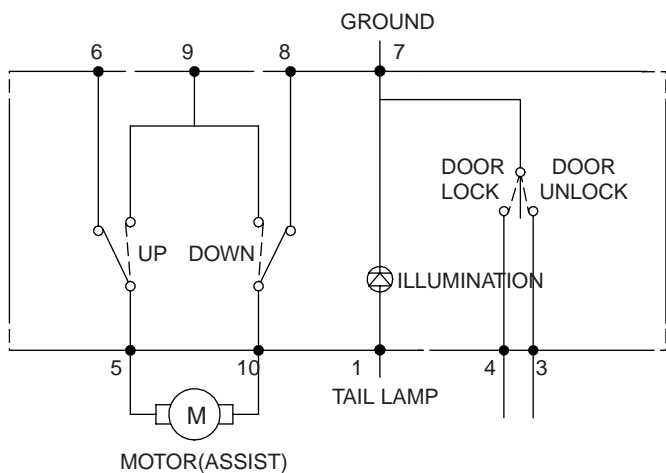

MOTOR (ASSIST)

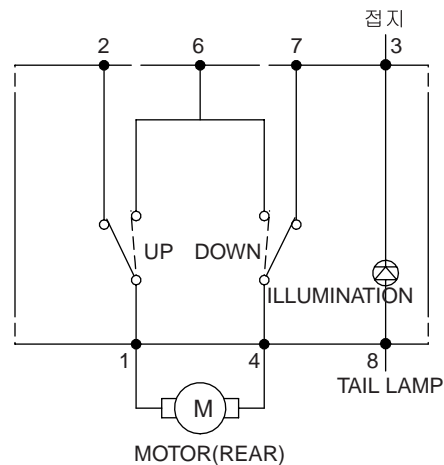

MOTOR (REAR)

[ With door lock switch : Assist ]

1	2	X		3	4
5	6	7	8	9	10

[ Without door lock switch : Assist or Rear ]

1	X		2	3
4	5	6	7	8

**INSPECTION** E7A0517B

**POWER WINDOW MAIN SWITCH INSPECTION**

1. Remove the negative (-) battery terminal.
2. Remove the power window switch module by pressing fixing clip part (B) with scraper (A).

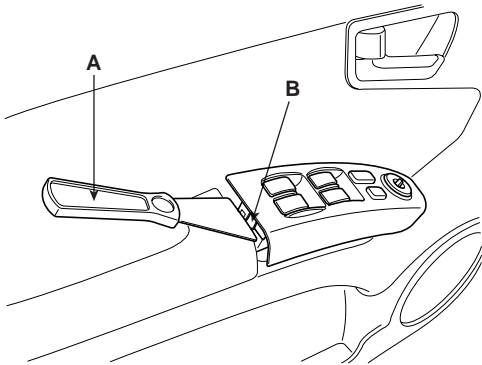

ATIE284A

3. Check for continuity between the terminals. If the continuity condition is not normal, replace the switch.

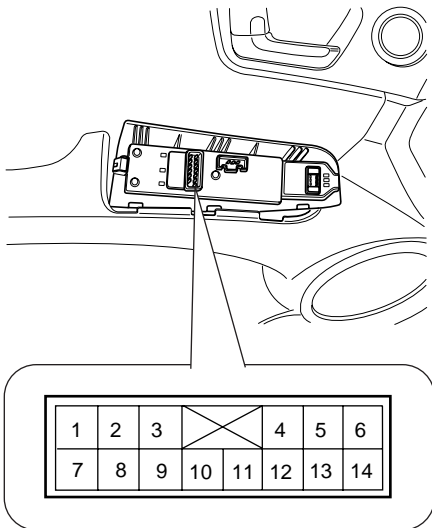

ATIE322D

**POWER WINDOW LOCK SWITCH**

Terminal Position	1	10
NORMAL	○	○
LOCK		

LTIF322E

Terminal Position	Front left				Front right			
	14	5	6	10	1	7	2	10
UP	○	○	○	○	○	○	○	○
OFF		○	○	○	○	○	○	○
DOWN	○	○	○	○	○	○	○	○

  

Terminal Position	Rear left				Rear right			
	12	14	13	10	8	7	9	10
UP	○	○	○	○	○	○	○	○
OFF	○		○	○	○	○	○	○
DOWN	○		○	○	○	○	○	○

LTIF322F

**ASSIST POWER WINDOW SWITCH**

1. Remove the negative (-) battery terminal.
2. Remove the power window switch module by pressing fixing clip part (B) with scraper (A).

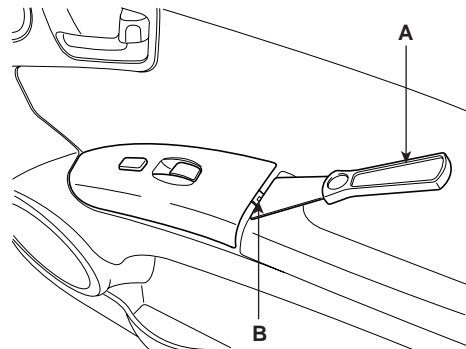

ATIE284D

3. Check for continuity between the terminals. If the continuity condition is not normal, replace the switch.

**REAR POWER WINDOW SWITCH INSPECTION**

1. Remove the negative (-) battery terminal.
2. Remove the power window switch module by pressing fixing clip part (B) with scraper (A).

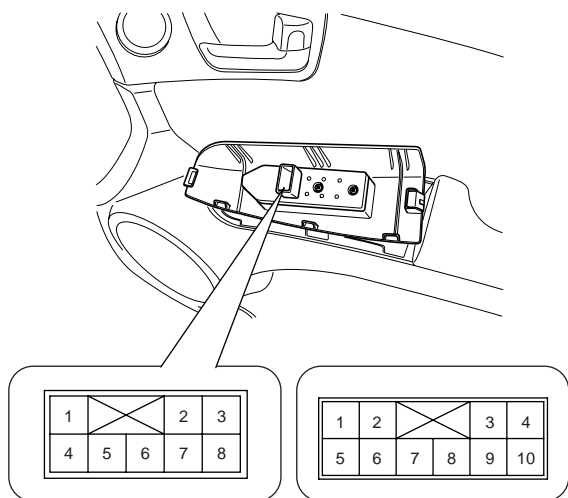

[Without door lock switch]

[With door lock switch]

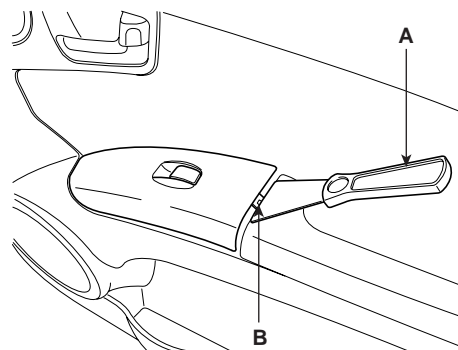

LTIF322G

ATIE322H

**[WITHOUT DOOR LOCK SWITCH]**

Terminal Position \	1	2	4	6	7
UP	○		○	○	○
OFF	○	○	○		○
DOWN	○	○	○		

ETQF946A

**[WITH DOOR LOCK SWITCH]**

Terminal Position \	5	6	8	9	10
UP	○		○	○	○
OFF	○	○	○		○
DOWN	○	○		○	○

ETQF947A

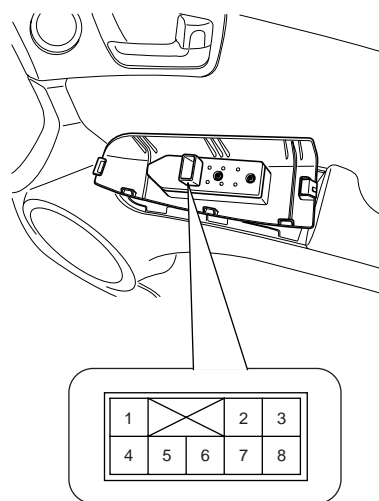

ATIE322I

Terminal Position \	1	2	4	6	7
UP	○		○	○	○
OFF	○	○	○		○
DOWN	○	○	○	○	

ETQF946A

## WINDSHIELD GLASS DEICER

### COMPONENTS EF52BE98

Windshield glass deicer system prevent windshield wiper from freezing in the winter season. It consists of deicer in the lower part of windshield glass, switch and relay. ETACS module receives an input signal from the deicer switch, then controls relay. Operating condition is the same that of rear window defogger system.

Since the alternator "L" is switched ON, if the deicer switch is ON, then deicer output is ON for 20 minutes.

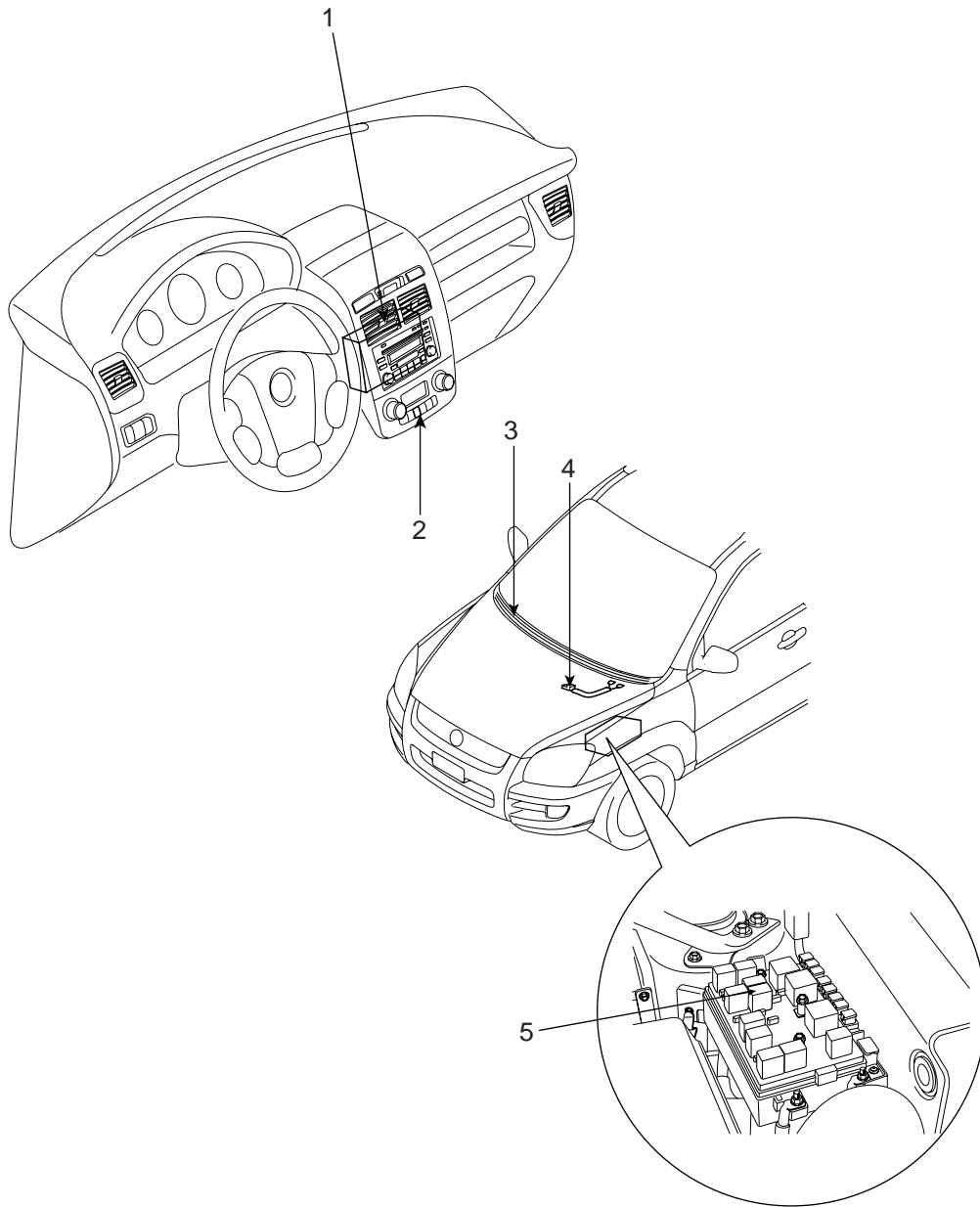

- 1. ETACS module
- 2. Windshield glass deicer switch
- 3. Windshield glass deicer

- 4. Deicer connector
- 5. Windshield glass deicer relay

## WINDSHIELD GLASS DEICER

### INSPECTION EA95EFED

1. Remove the cowl top cover.(Refer to wiper)
2. Disconnect the windshield glass deicer connector (A) from the wiper motor linkage.

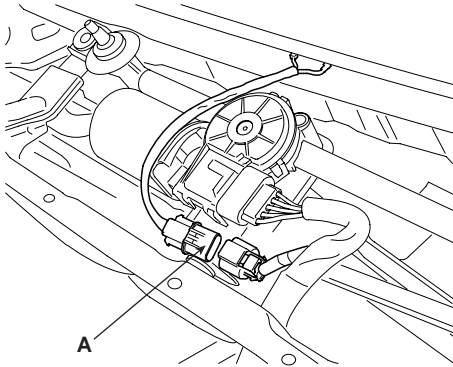

ATIE334B

3. Check for continuity between the terminals of deicer lines.

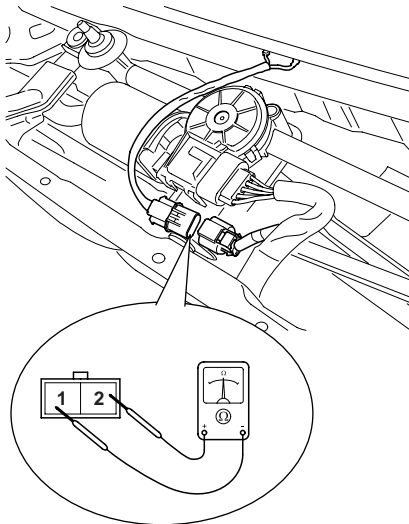

KTQE948A

4. Turn the ignition switch ON and the windshield deicer switch ON, then measure the voltage between the terminals of harness side deicer connector.

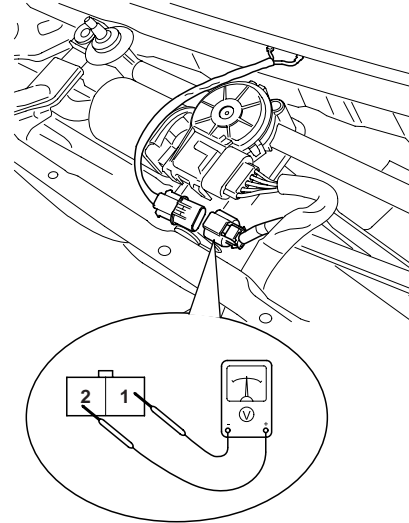

KTQE948B

---

O K : approx. Battery voltage

---

## WINDSHIELD GLASS DEICER SWITCH

### INSPECTION E694481F

1. Remove the negative (-) battery terminal.
2. Remove the center facia panel (C) by pressing hole of part (A) with driver. Take care of fixing clip (B).

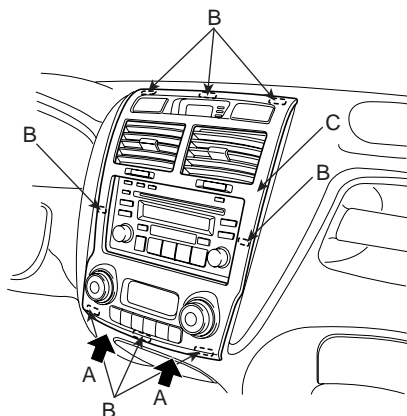

ATIE021A

3. Disconnect the connectors.
4. Using an ohmmeter, inspection the continuity between the terminals after removing to the switch connector.

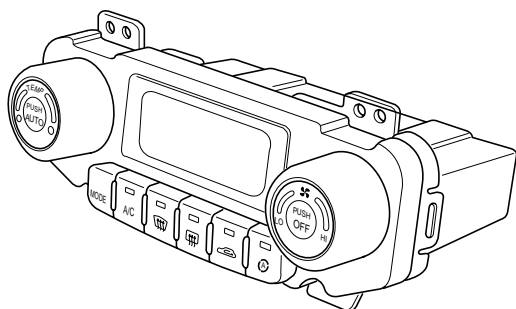

ATIE331A

Terminal Position	M05-2 (7)	M05-1 (3)	M04-2 (21)	M04-2 (13)	M04-1 (26)
ON (Manual)	○ — ○				
ON (Auto)			○ — ○ — ○		
OFF					

LTIF331B

## WINDSHIELD GLASS DEICER TIMER

### INSPECTION EFC324B1

1. Once ALT "L" is ON, if the defogger is switched ON, the defogger will stay ON for 20 minutes duration.
2. If defogger switch is pressed again (see Step 1), or if ignition is switched OFF, the defogger will shut OFF.

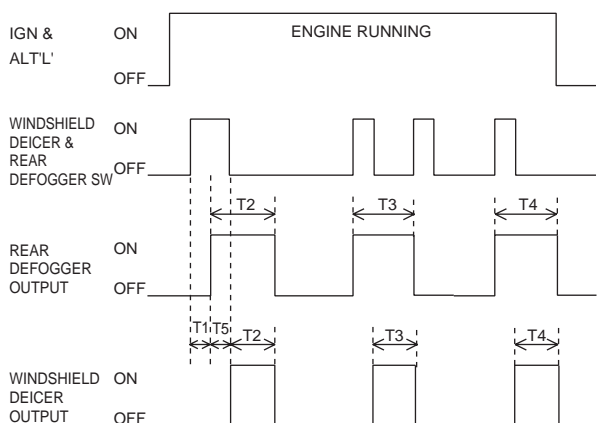

LTIF141J

T1 : 0.06 ± 0.01 sec.,  
T2 : 20 ± 1 min.

## WINDSHIELD GLASS DEICER RELAY

### INSPECTION E99D5582

1. Remove the negative (-) battery terminal.
2. Remove the windshield deicer relay (A) from the engine room relay box.
3. Check for continuity between the terminals.
4. There should be continuity between the No.87 and No.30 terminals when power and ground are connected to the No.86 and No.85 terminals.
5. There should be no continuity between the No.87 and No.30 terminals when power is disconnected.

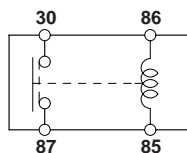
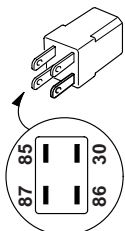
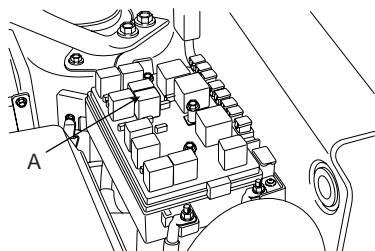

ATIE334A

Terminal	30	87	85	86
Power				
Disconnected			○ — ○	
Connected	○ — ○		⊖ — ⊕	

LTIF221B

## REAR WINDOW DEFOGGER

### COMPONENTS E0BDAC63

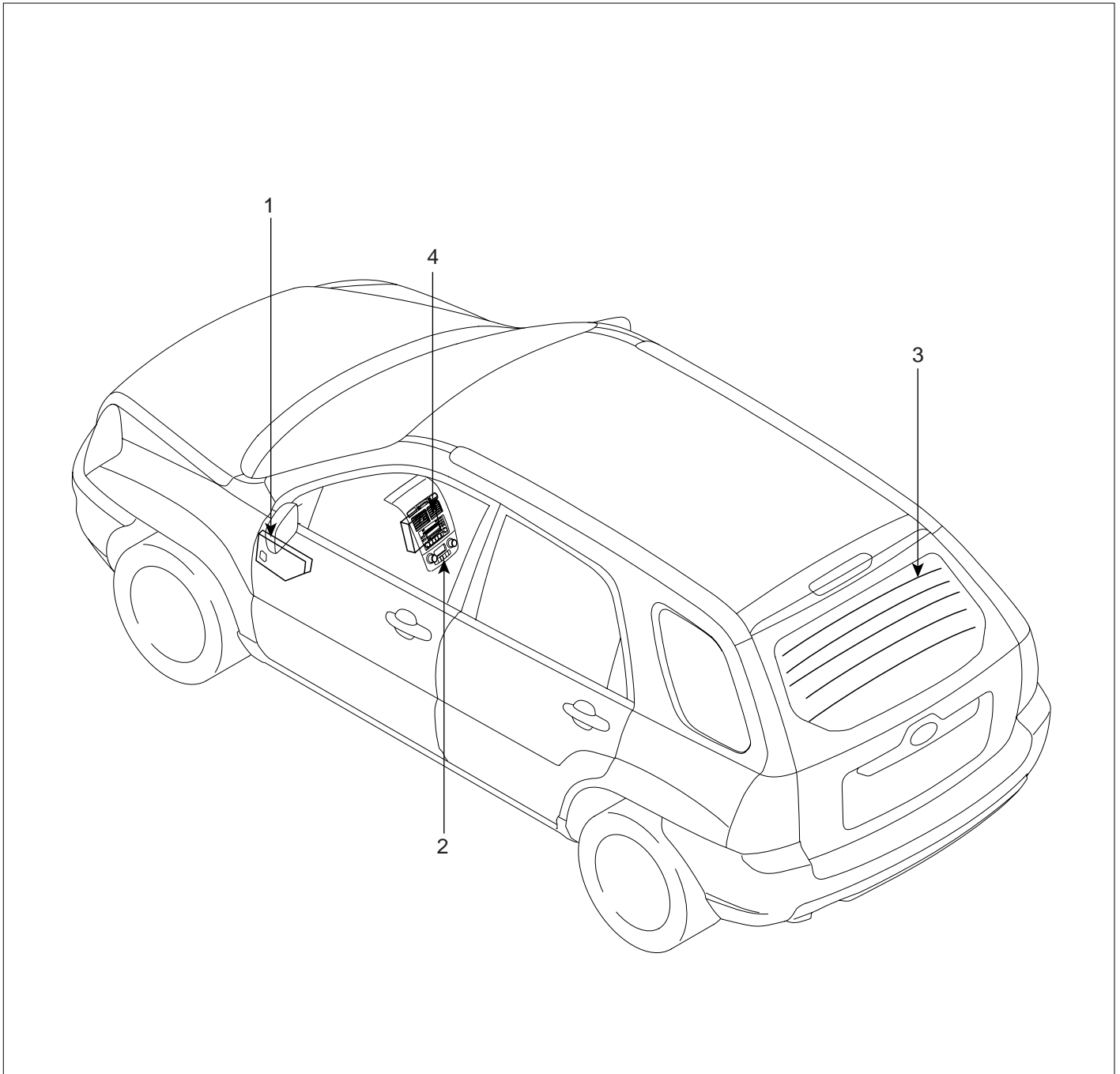

- 1. Passenger compartment junction box
- 2. Rear window defogger switch

- 3. Rear window defogger
- 4. ETACS module

LTIF340B

REAR WINDOW DEFOGGER  
PRINTED HEATER

INSPECTION EE1A8355

 CAUTION

Wrap tin foil around the end of the voltmeter test lead to prevent damaging the heater line. Apply finger pressure on the tin foil, moving the tin foil along the grid line to check for open circuits.

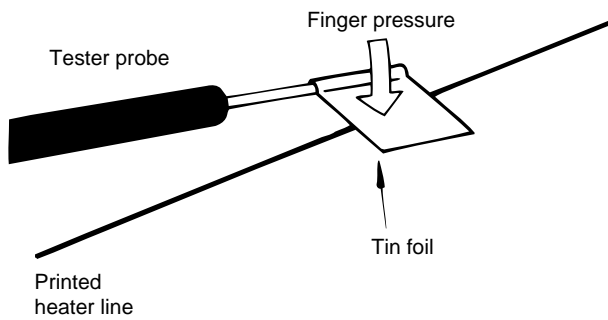

ETA9165A

1. Turn on the defogger switch and use a voltmeter to measure the voltage of each heater line at the glass center point. If a voltage of approximately 6V is indicated by the voltmeter, the heater line of the rear window is considered satisfactory.

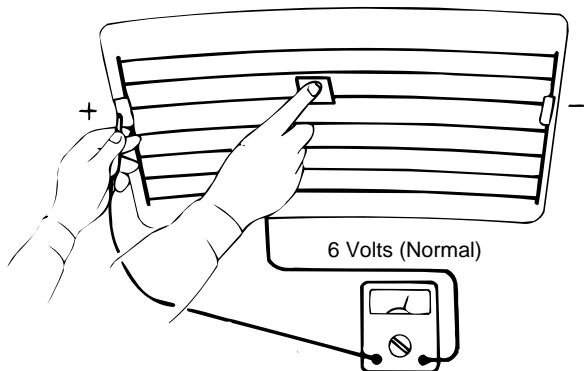

ETA9165B

2. If a heater line is burned out between the center point and (+) terminal, the voltmeter will indicate 12V.

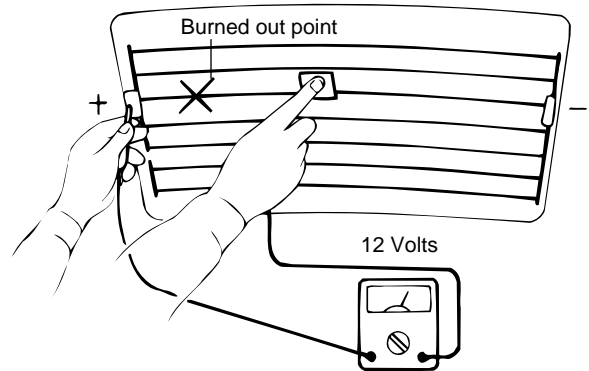

ETA9165C

3. If a heater line is burned out between the center point and (-) terminal, the voltmeter will indicate 0V.

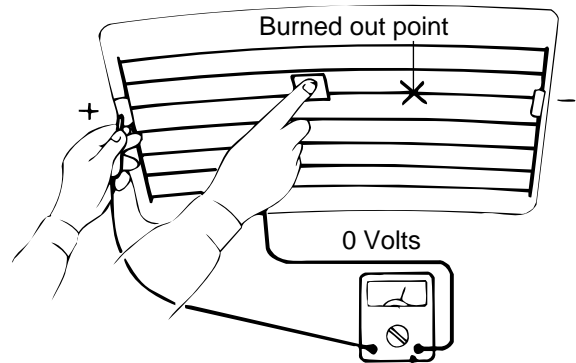

ETA9165D

4. To check for open circuits, slowly move the test lead in the direction that the open circuit seems to exist. Try to find a point where a voltage is generated or changes to 0V. The point where the voltage has changed is the open-circuit point.

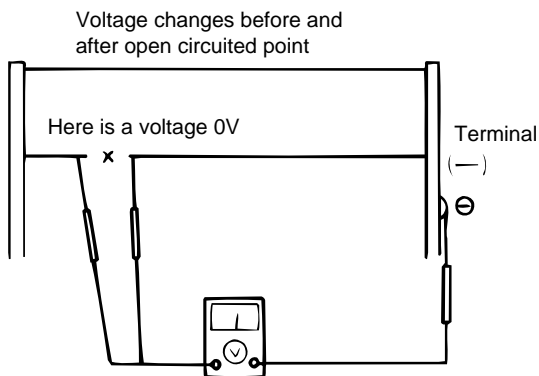

ETA9165E

5. Use an ohmmeter to measure the resistance of each heater line between a terminal and the center of a grid line, and between the same terminal and the center of one adjacent heater line. The section with a broken heater line will have a resistance twice as that in other sections. In the affected section, move the test lead to a position where the resistance sharply changes.

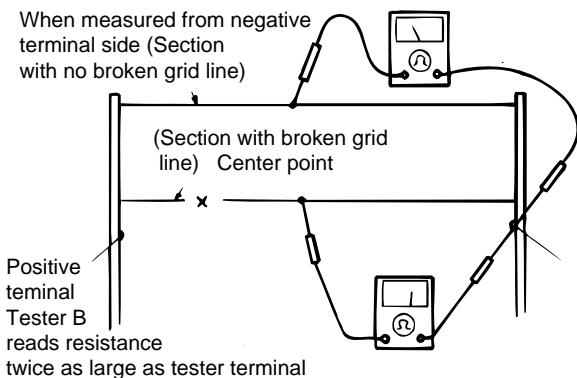

ETA9165F

### REPAIR OF BROKEN HEATER LINE

Prepare the following items :

1. Conductive paint.
2. Paint thinner.
3. Masking tape
4. Silicone remover.
5. Using a thin brush :  
Wipe the glass adjacent to the broken heater line, clean with silicone remover and attach the masking tape as shown. Shake the conductive paint container well, and apply three coats with a brush at intervals of about 15 minutes apart. Remove the tape and allow sufficient time for drying before applying power. For a better finish, scrape away excess deposits with a knife after the paint has completely dried. (Allow 24 hours).

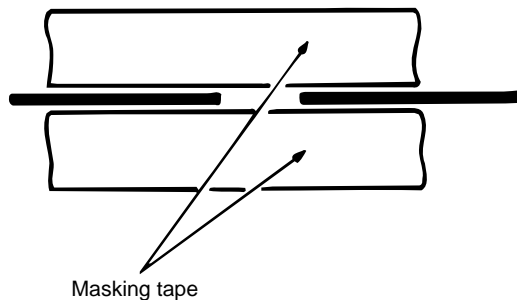

ETA9165G

**REAR WINDOW DEFOGGER SWITCH**

**INSPECTION** E6506ADF

1. Disconnect the negative (-) battery terminal.
2. Remove the center facia panel (C) after pulling it by using regular screw driver(-) at part (A). Take care of fixing clips (B).

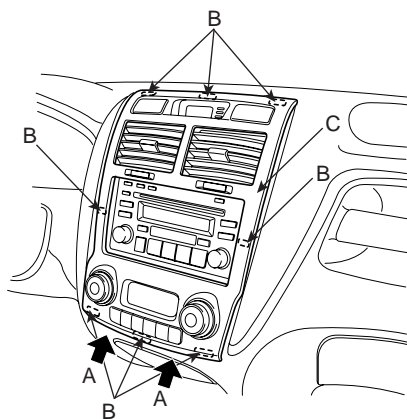

ATIE021A

3. Disconnect the connectors.

4. Using an ohmmeter, inspection the continuity between the terminals after removing to the switch connector.

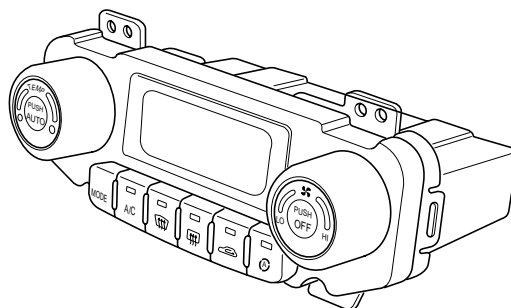

ATIE331A

Terminal Position	M05-2 (7)	M05-1 (3)	M04-2 (21)	M04-2 (13)	M04-1 (26)
ON (Manual)	○	○			
ON (Auto)			○	○	○
OFF					

LTIF331B

## REAR WINDOW DEFOGGER RELAY

### INSPECTION E4578C2E

1. Remove the negative (-) battery terminal.
2. Remove the junction box.
3. Check for continuity between the terminals.
4. There should be continuity between the No.1 in the I/P-J terminal and No.7 in the I/P-F terminal when power and ground are connected to the No.14 in the I/P-D terminal and No.7 in the I/P-C terminal.
5. There should be no continuity between the No.1 in the I/P-J terminal and No.7 in the I/P-F terminal when power is disconnected.

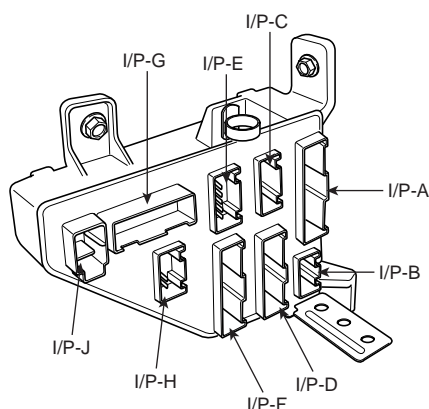

ATIE323A

Terminal Position	I/P-C (7)	I/P-D (14)	I/P-J (1)	I/P-F (7)
Disconnected	○	○		
Connected	⊖	⊕	○	○

LTIF342B

## REAR WINDOW DEFOGGER TIMER

### INSPECTION E90D615A

1. Once ALT "L" is ON, if the defogger is switched ON, the defogger will stay ON for 20 minutes duration.
2. If defogger switch is pressed again (see Step 1), or if ignition is switched OFF, the defogger will shut OFF.

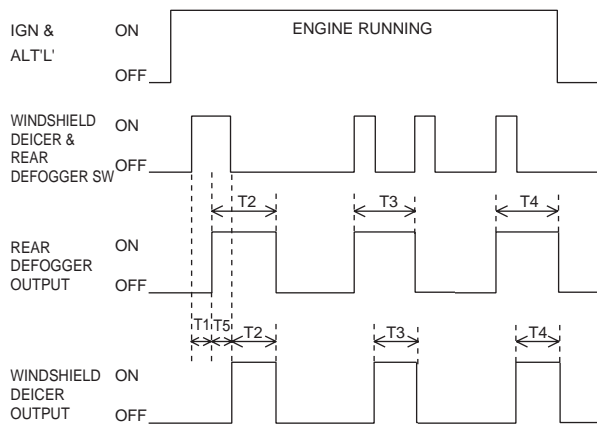

LTIF141J

T1 : 0.06 ± 0.01 sec.,  
T2 : 20 ± 1 min.

## WINDSHIELD WIPER / WASHER

COMPONENT E346F2F6

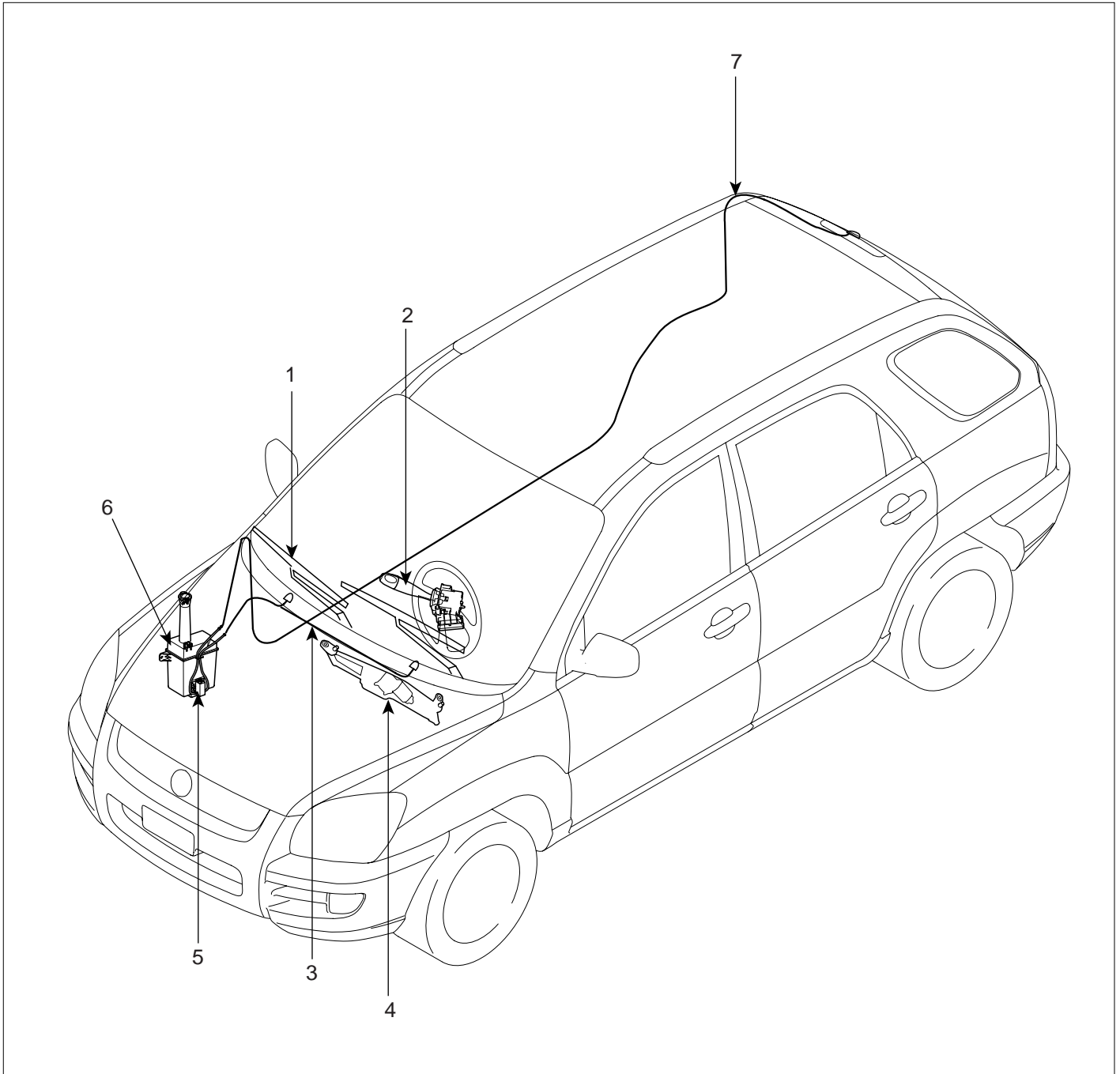

- 1. Windshield wiper arm & blade
- 2. Wiper & washer switch
- 3. Windshield washer hose
- 4. Windshield washer motor & linkage

- 5. Washer motor
- 6. Washer reservoir
- 7. Rear washer hose

LTIF360A

## WINDSHIELD WIPER / WASHER SWITCH

### REPLACEMENT ED1E47E9

1. Remove the steering column upper and lower shrouds (A) after removing 3 screws.

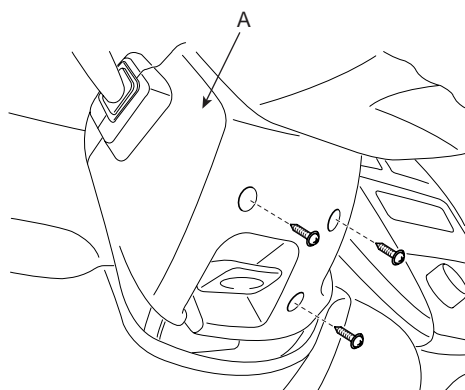

ATIE031B

2. Remove the wiper switch (B) after loosening its 2 screws and connector (A).

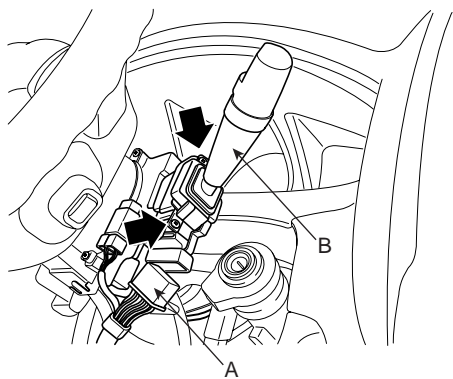

LTIF031D

3. Installation is the reverse of removal.

### INSPECTION E0CE50F4

Check for continuity between the terminals while operating the wiper and washer switch. If it is not normal condition, replace wiper and wiper switch.

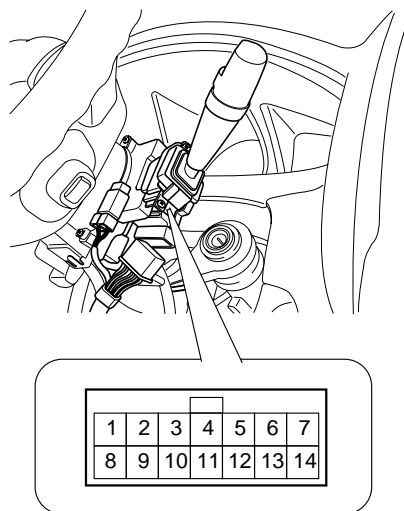

ATIE031G

### WIPER SWITCH

Terminal Position	1	2	3	4	5	6	13	14
MIST				○—○				
OFF		○—○						
INT		○—○			○—○		○—○	○—○
LOW		○—○			○—○			
HI	○—○				○—○			

ETDD075C

### WASHER SWITCH

Terminal Position	5	7
OFF		
ON	○—○	○—○

ETDD075D

# FRONT WIPER MOTOR

## COMPONENTS E52BF8B3

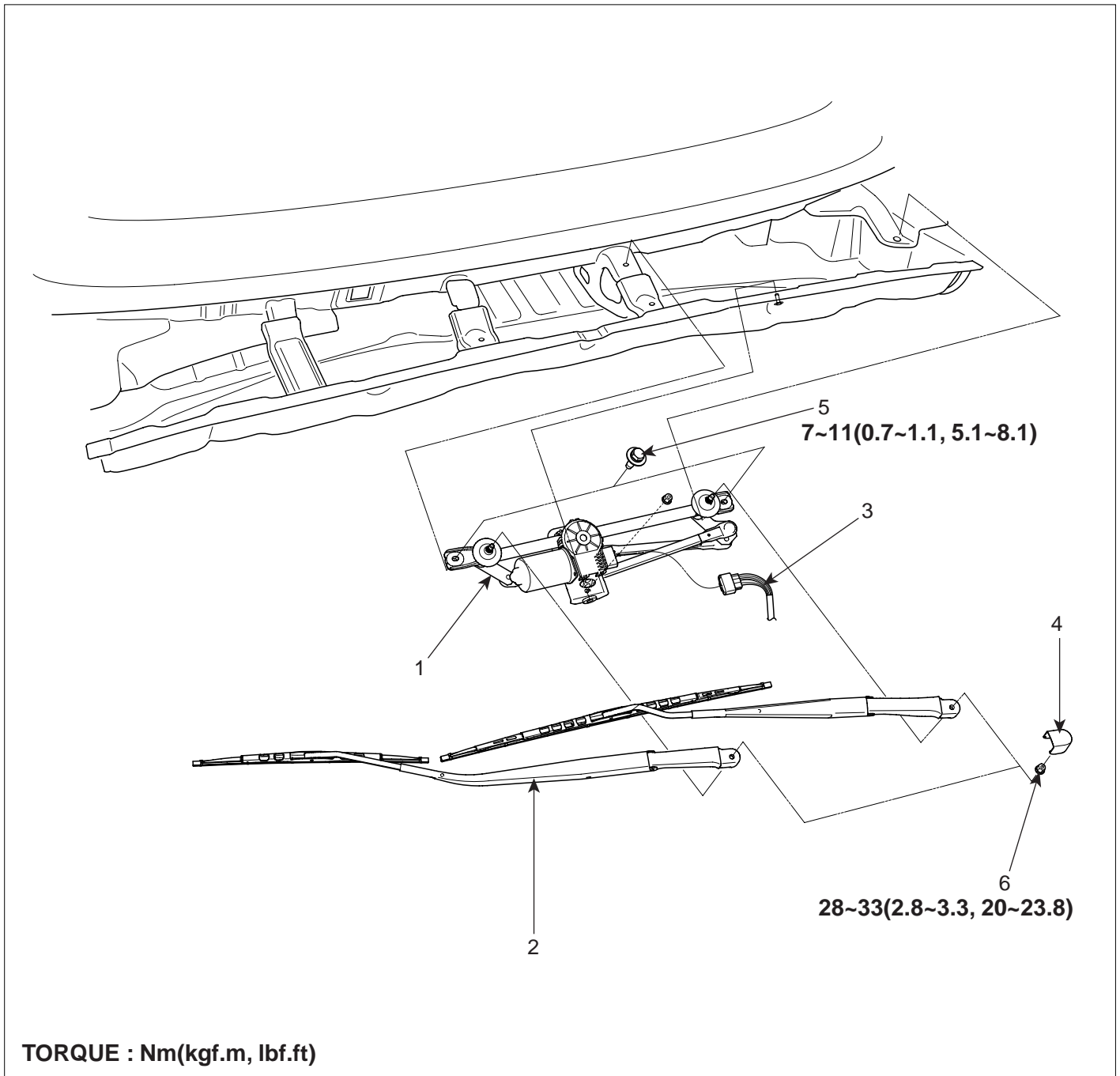

- 1. Wiper motor & link assembly
- 2. Wiper arm & blade
- 3. Wiper motor connector

- 4. Cap
- 5. Bolt
- 6. Nut

LTIF362A

## WINDSHIELD WIPER / WASHER

BE -127

### REMOVAL EFE42F4E

1. Remove the windshield wiper arm and blade after removing a nut (A).

TORQUE :  
28~33 Nm (2.8~3.3 kgf.m, 20~23.8 lbf.ft)

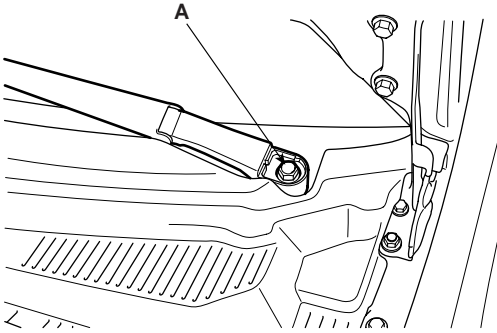

ETKE365A

2. Remove the weather strip then remove the cowl top cover (A) after removing 3 clips (B).

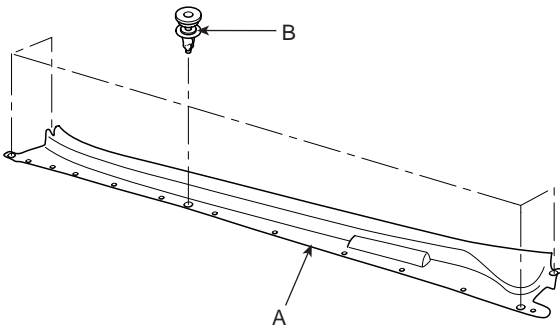

ATIE362C

3. Remove the windshield wiper motor and linkage assembly after removing 2 bolts and a nut. Disconnect the wiper motor connector (A) and windshield deicer connector (B) from the wiper motor & linkage assembly.

TORQUE :  
7~11Nm (0.7~1.1kgf.m, 5.1~8.1 lbf.ft)

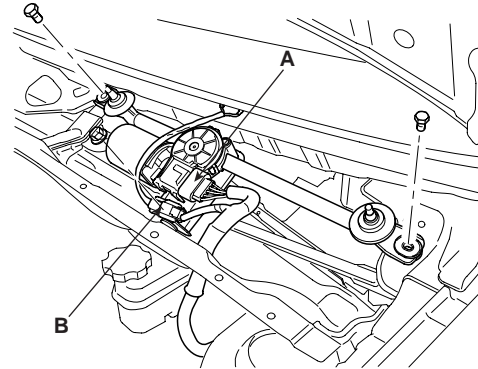

ATIE362D

4. Installation is the reverse of removal.

**INSPECTION** EFDA3CF0

**SPEED OPERATION CHECK**

1. Remove the connector from the wiper motor.
2. Attach the positive (+) lead from the battery to terminal 4 and the negative (-) lead to terminal 1.
3. Check that the motor operates at low speed.
4. Connect the positive (+) lead from the battery to terminal 5 and the negative (-) lead to terminal 1.
5. Check that the motor operates at high speed.

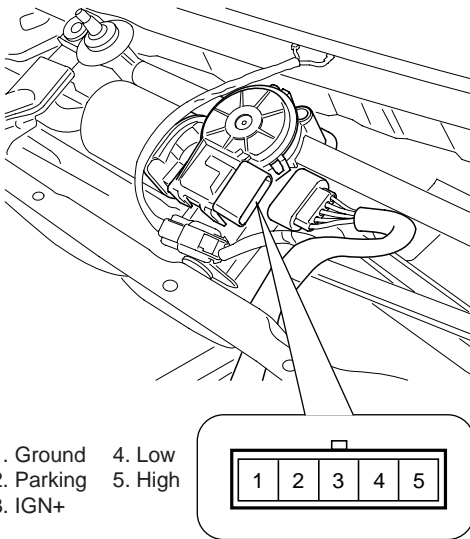

**AUTOMATIC STOP OPERATION CHECK**

1. Operate the motor at low speed using the stalk control
2. Stop the motor operation anywhere except at the off position by disconnecting terminal 4
3. Connect terminals 4 and 2.
4. Connect the positive (+) lead from the battery to terminal 3 and the negative (-) lead to terminal 1.
5. Check that the motor stops running at the off position.

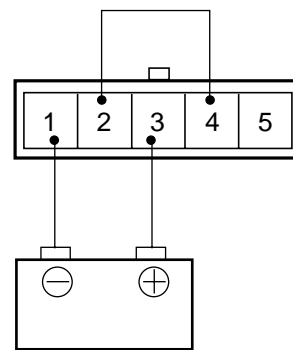

ATIE362E

LTIF310B

**INSTALLATION** EA0FBCFB

1. Install the wiper arm and blade to the specified position.

Specified position	A	B
Distance [in (mm)]	$1.26 \pm 0.2$ (32 ± 5)	$1.26 \pm 0.2$ (32 ± 5)

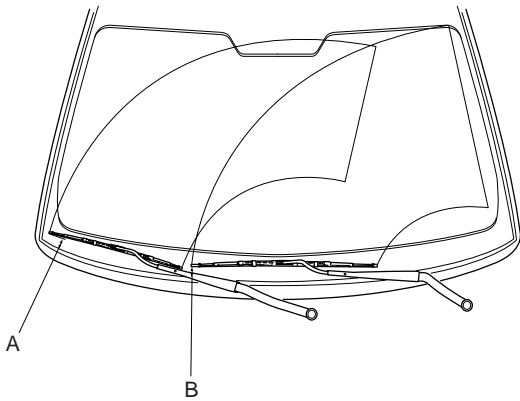

ATGE362C

2. Set the washer nozzle on the specified spray position.

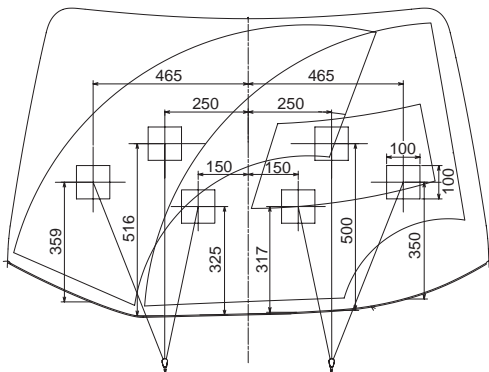

Unit : mm

LTIF362F

## FRONT WASHER MOTOR

### REPLACEMENT E4B36D7E

1. Disconnect the negative (-) battery terminal.
2. Remove the front bumper cover. (Refer to BD group - Front bumper)
3. Remove the washer hose and the washer motor connector (A).
4. Remove the washer reservoir after removing 2 bolts.

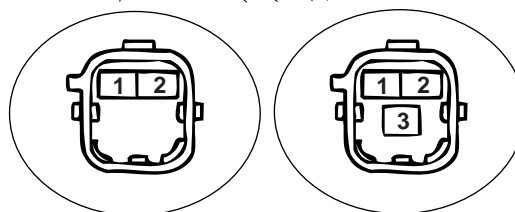
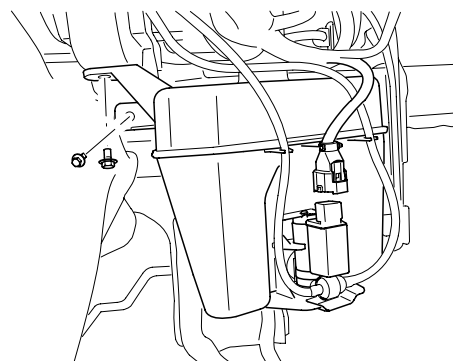
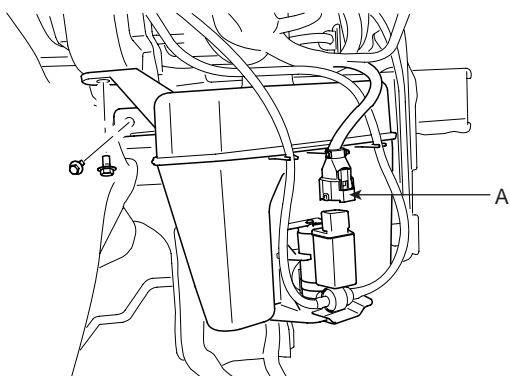

[Windshield washer]

1. Ground
2. Windshield washer(+)

[Windshield & rear washer]

1. Ground
2. Windshield washer(+)
3. Rear washer(+)

ETQF954A

5. Installation is the reverse of removal.

ATIE363A

### INSPECTION EFB5B6F8

1. With the washer motor connected to the reservoir tank, fill the reservoir tank with water.
2. Connect positive (+) battery cables to terminal 2 and negative (-) battery cables to terminal 1 respectively.
3. Check that the motor operates normally and the washer motor runs and water sprays from the front nozzles.
4. If they are abnormal, replace the washer motor.

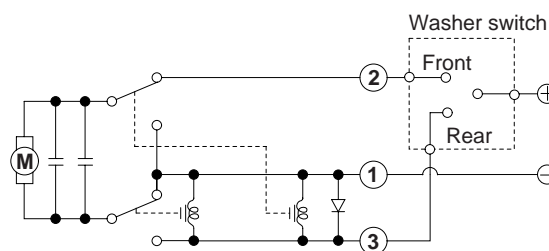

<Windshield & Rear washer motor>

LTIF363B

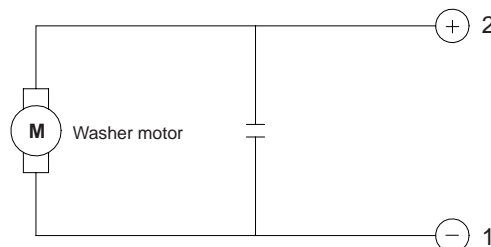

[ Windshield washer motor ]

LTIF363C

# REAR WIPER / WASHER

COMPONENT E41062CB

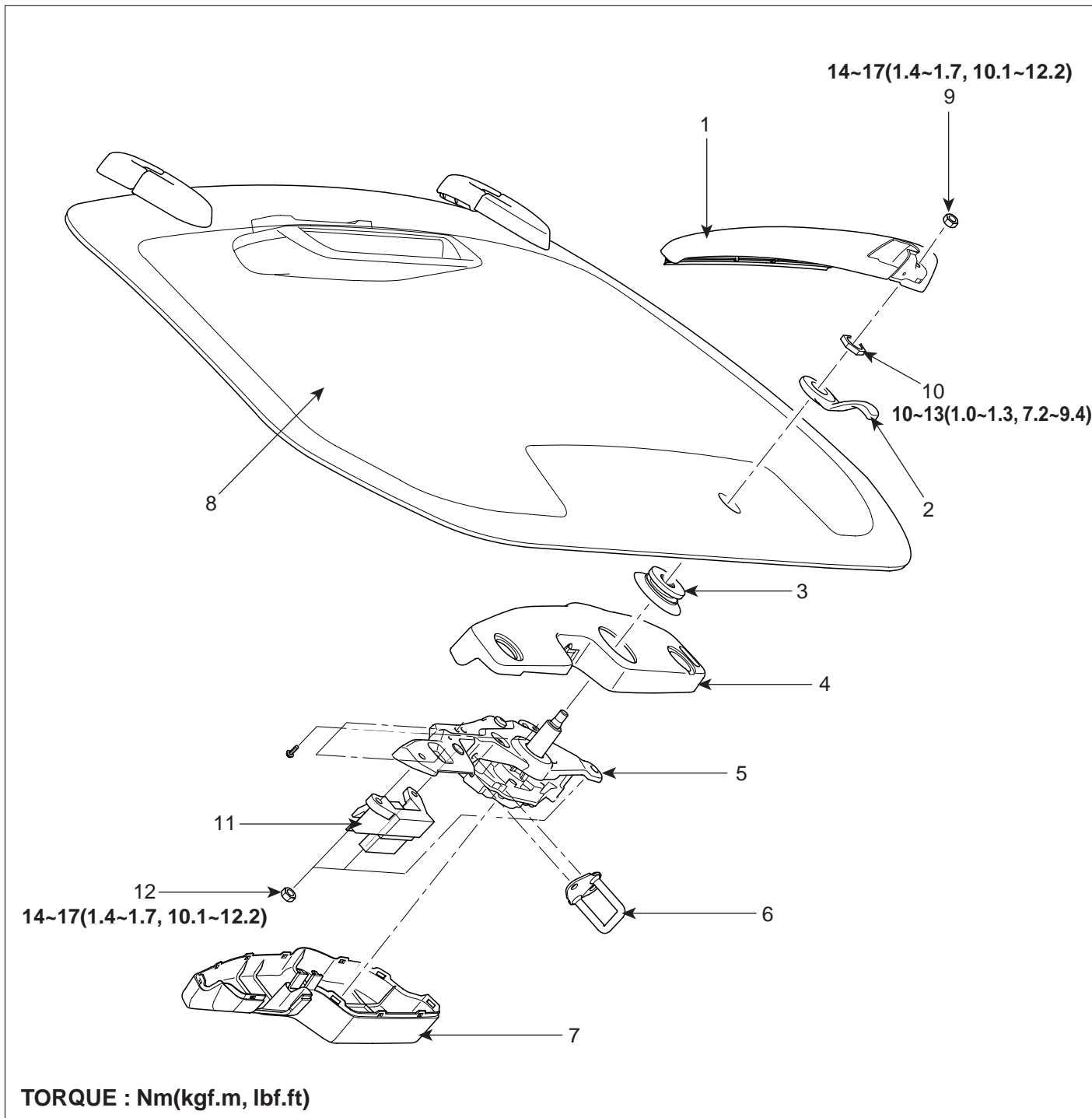

- |                              |                   |
|------------------------------|-------------------|
| 1. Rear wiper arm & blade    | 7. Cover          |
| 2. Tailgate glass handle     | 8. Tailgate glass |
| 3. Grommet                   | 9. Nut            |
| 4. Cover                     | 10. Nut           |
| 5. Rear wiper motor assembly | 11. Switch        |
| 6. Striker                   | 12. Nut           |

## REAR WIPER MOTOR

### REMOVAL EC84C702

1. Detach the wiper cap (A), then remove the rear wiper arm after removing a nut (B).

Tightening torque Nut(B) :  
14~17 Nm (1.4~1.7 kgf.m, 10.1~12.3 lbf.ft)

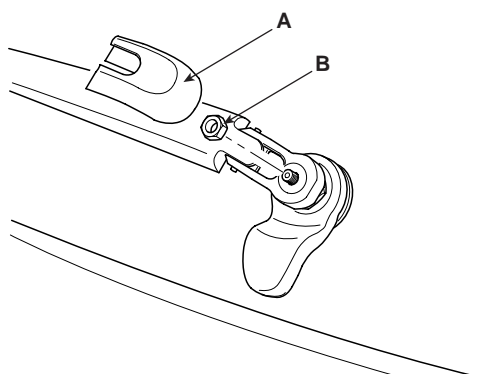

ATIE380B

2. Remove the handle (B) after removing a nut (A).

Tightening torque Nut (A) :  
10~13 Nm (1.0~1.3 kgf.m, 7.2~9.4 lbf.ft)

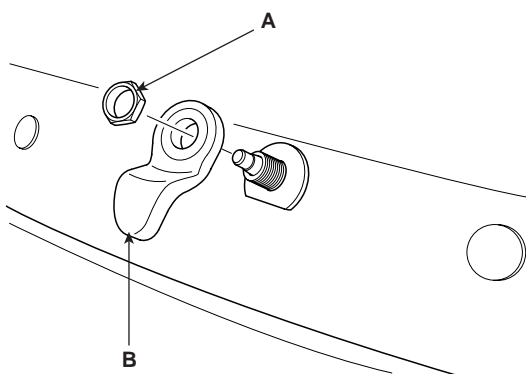

ATIE380C

3. Open the tailgate glass then remove the rear wiper motor cover (A).

4. Disconnect the rear wiper motor connector then remove the rear wiper motor (B) after removing 3 nuts.

Tightening torque Nut :  
14~17 Nm (1.4~1.7 kgf.m, 10.1~12.3 lbf.ft)

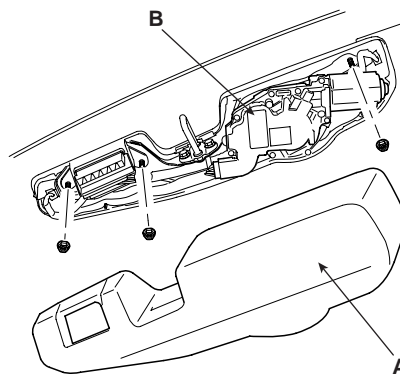

ATIE380D

5. Installation is the reverse of removal.

### INSPECTION E0C3A76E

1. Remove the 4P connector from the rear wiper motor.
2. Connect battery positive (+) and negative (-) cables to terminals 3 and 4 respectively.
3. Check that the motor operates normally. Replace the motor if it operates abnormally.

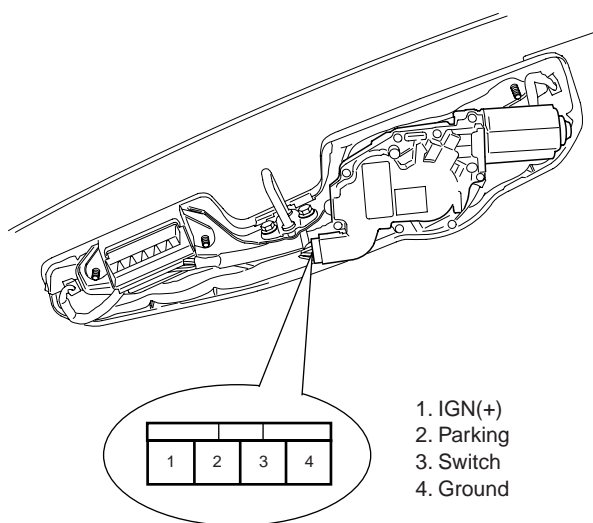

ETQF957A

**AUTOMATIC STOP OPERATION CHECK**

1. Operate the motor at low speed using the stalk control.
2. Stop the motor operation anywhere except at the off position by disconnecting terminal 3.
3. Connect terminals 2 and 3.
4. Connect the positive (+) lead from the battery to terminal 1 and the negative (-) lead to terminal 4.
5. Check that the motor stops running at the off position.

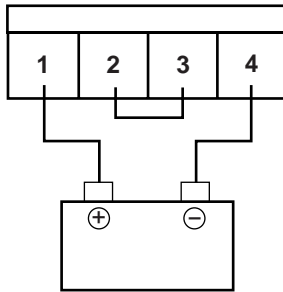

ATGE381F

**INSTALLATION**

ECA7BD85

1. Install the rear wiper arm and blade to the specified position.

Specified position	A
Distance	19 ± 5 mm

Specified position : The first deicer line from bottom of the rear window.

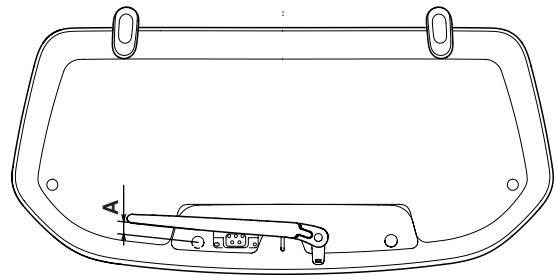

ATIE381A

2. Set the rear washer nozzle on the specified spray position.

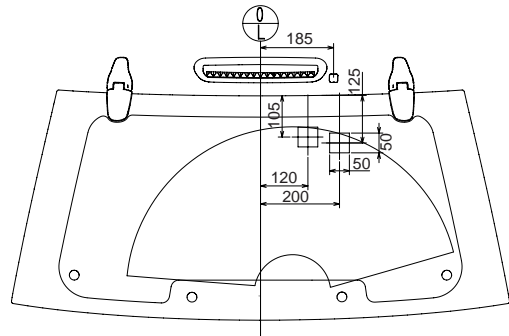

Unit : mm

LTIF381B

## REAR WASHER SWITCH

### INSPECTION EC7FC86D

With the rear wiper & washer switch in each position, make sure that continuity exists between the terminals below. If continuity is not as specified, replace the multifunction switch.

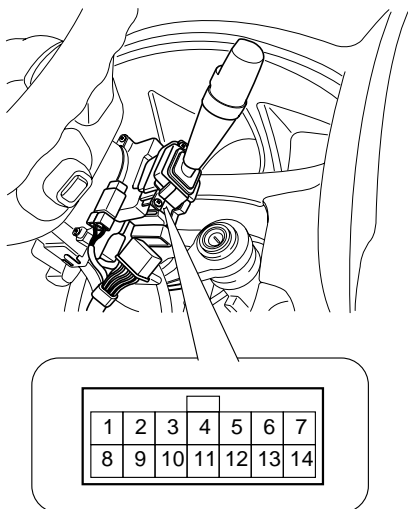

ATIE031G

### REAR WIPER & WASHER SWITCH

Terminal Position	9	10	11	12
Rear washer	○	—	—	○
OFF				
INT	○	○		
ON	○	—	○	
Rear washer	○	—	—	○

LTIF958A

## REAR WASHER MOTOR

### INSPECTION EBCD5BB3

1. With the washer motor connected to the reservoir tank, fill the reservoir tank with water.
2. Remove the front bumper cover. (Refer to the BD group- Front bumper cover)
3. Connect positive (+) and negative (-) battery cables to terminals 3 and 1 respectively to see that the washer motor runs and water is pumped.
4. Check that the motor operates normally.  
Replace the motor if it operates abnormally.

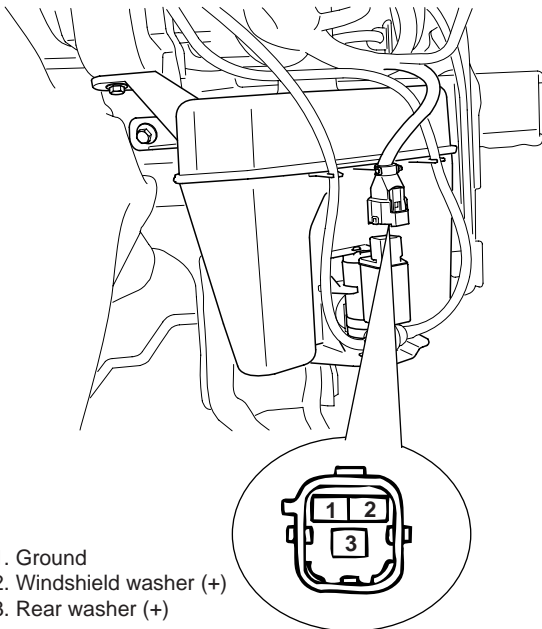

ETQF220E

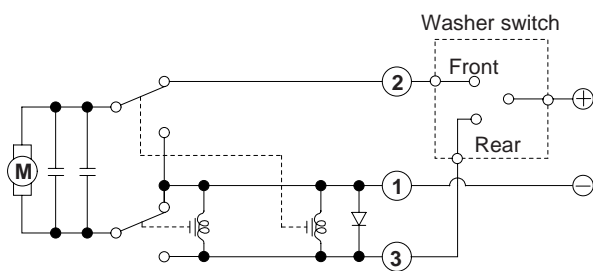

<Windshield & rear washer motor>

ETQF390B

## ELECTROCHROMIC INSIDE REAR VIEW MIRROR

### DESCRIPTION ECA0F1F4

The ECM (Electro Chromic inside rear view Mirror) is for dimming the reflecting light from a vehicle behind at night, in order the user not to be dazzled by the light. The front looking sensor detects brightness of the surroundings, while the rearward looking sensor the strength of the reflecting light so that adjusts the reflexivity of the mirror in the range of 10~70%. But, when the reverse gear is engaged, it stops functioning.

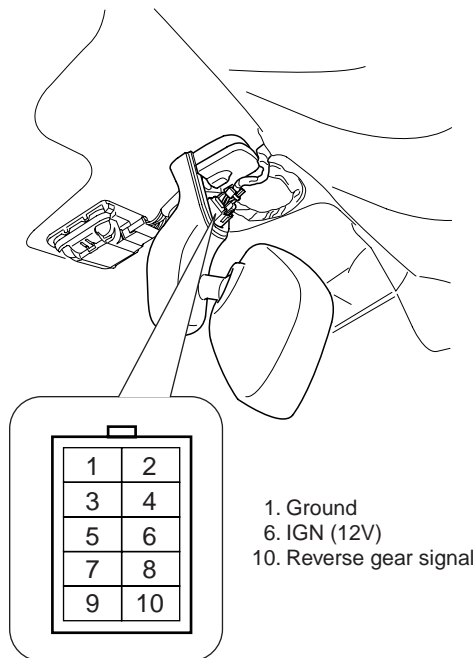

ETQE280J

1. The front looking sensor sees if the brightness of the surroundings is low enough for the mirror to operate its function.
2. The rearward looking sensor detects glaring of the reflecting light from a vehicle behind.

3. The ECM is darkened to the level as determined by the rearward looking sensor. When the glaring is no longer detected, the mirror stops functioning.

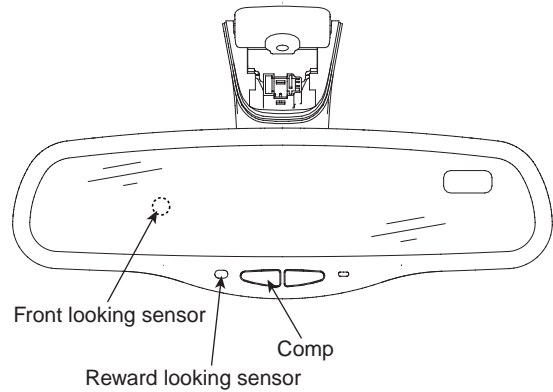

ETQE999A

### COMPASS MIRROR E39BE70E

#### FUNCTION OF THE COMPASS MIRROR

1. Push the 'COMP' button lower of the rear view mirror to turn on the function of the compass mirror so that displays a sign of a direction on the small board in the upper-right side of the mirror.
2. Push the 'COMP' button again to turn off its function.

#### CALIBRATION PROCEDURE

If the compass has been calibrated or set to variance zone number incorrectly, or you are driving in specific places (tunnel, parking lot in building, underground parking lot, near transformer substation, etc.), some phenomenon is occur as follows:

- The display read "C".
- The compass headings become inaccurate.
- The compass heading is not changed.
- Some compass headings are not displayed.
- The compass headings are inaccurate in long distance driving.

This compass automatically calibrates itself while the vehicle is driven as your route takes you in complete circles.. If the vehicle's compass headings become inaccurate continuously, the compass should be manually calibrated as follows:

1. Move the vehicle from the large steel structure or electric power supply cable.
2. Turn on the compass by pressing the COMP button.

3. Check the zone number by pressing the COMP button for more than 4 seconds until the current zone number appears in the display.  
To re-calibrate, hold the COMP button for 3 seconds until C is displayed. If the zone number is different for your country, set the correct zone number referring to "Setting the compass zone" and do the "Calibration procedure" again.
4. Drive your vehicle in at least 2 circles at less than 5 miles per hour (8 km/h) until the compass heading appears. Driving in a circle in right-handed direction and opposite direction are possible and if possible, stop the wiper operation.
5. If the vehicle's compass headings become inaccurate as before, do the following procedure again.

 **NOTE**

*If new vehicle is first driven or if the battery has been disconnected, do the calibration procedure as above.*

**SETTING THE COMPASS ZONE**

This compass must be set to compensate for the variation between true north and magnetic north. To set variation:

1. Find your current location and variance zone number on the zone map. (Refer to owner's manual)
2. Press the COMP button for more than 4 seconds. The current zone number will appear in the display.
3. Release and press the COMP button until the new zone number appears in the display. After you stop pressing the button in, the display will show a compass direction within a few seconds.

 **WARNING**

1. **Do not install the ski rack, antenna, etc. which are attached to the vehicle by means of a magnet. They affect the operation of the compass**
2. **If the compass deviates from the correct indication soon after repeated adjustment, have the compass checked at an authorized dealer.**
3. **The compass may not indicate the correct compass point in tunnels or while driving up or down a steep hill. (The compass returns to the correct compass point when the vehicle moves to an area where the geomagnetism is stabilized.)**

**INSPECTION** E64B8E88

Check it by the procedure below to see if the function of the ECM is normal.

1. Turn the ignition key to the "ON" position.
2. Cover the front looking sensor to stop functioning.
3. Head a light to the rearward looking sensor.
4. The ECM should be darkened as soon as the rearward looking sensor detects the light.

 **NOTE**

*If this test is performed in daytime, the ECM may be darkened as soon as the front looking sensor is covered.*

5. When the reverse gear is engaged, the ECM should not be darkened
6. When heading lights to both the front looking and rearward looking sensors, the ECM should not be darkened.

# SEAT WARMER

## COMPONENTS EE7E83BC

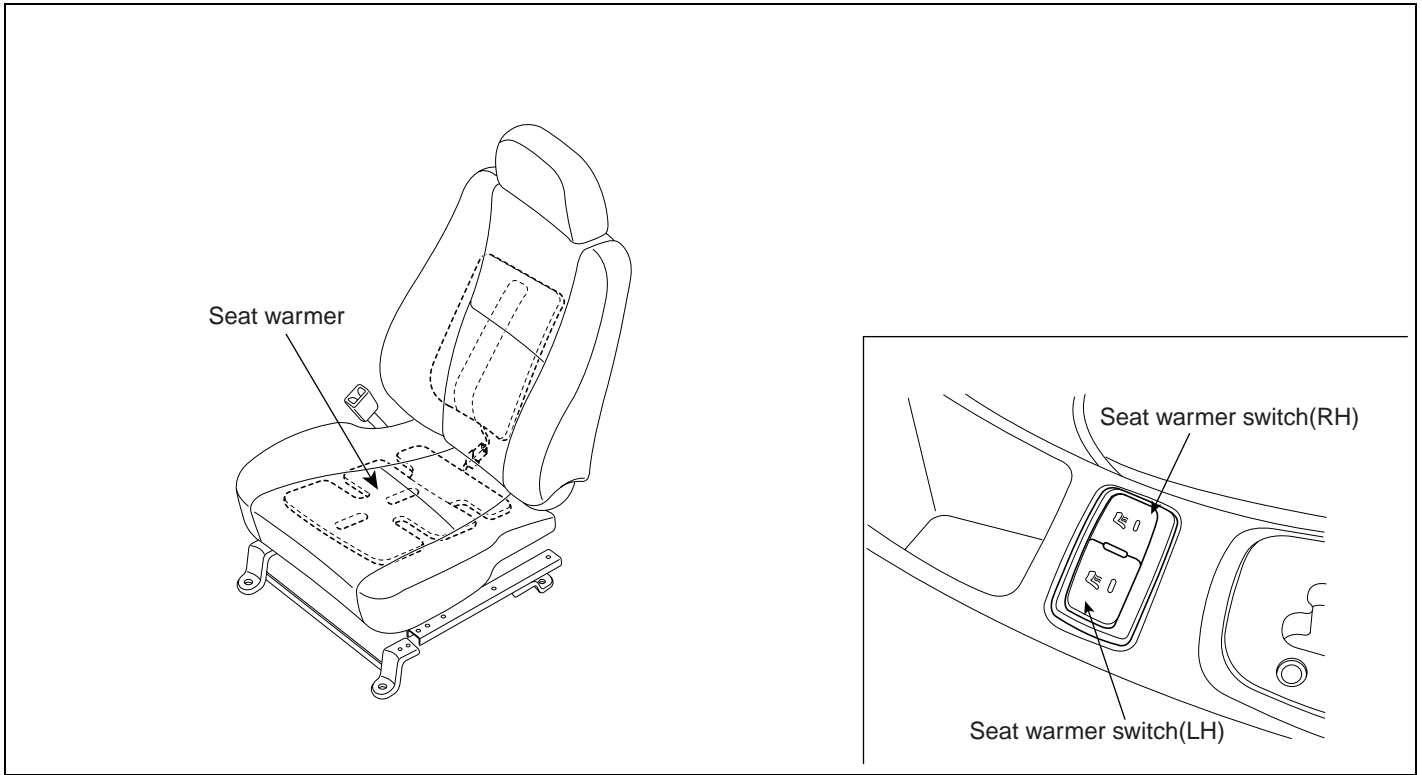

LTIF440A

**SEAT WARMER SWITCH**

**INSPECTION** E7B13F8A

1. Disconnect the negative (-) battery terminal.
2. Remove the seat warmer switch from the floor console upper cover with scraper (A).

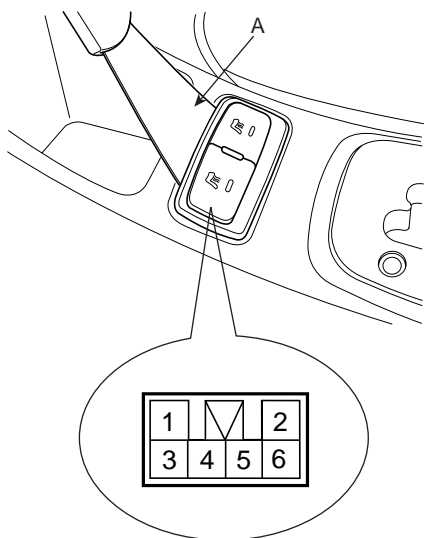

ATIE441A

3. Check for continuity between the terminals in each switch position according to the table.

Terminal Position	2	6	1	4	3
ON					
OFF	Illumination				

LTIF441B

**SEAT WARMER INSPECTION**

1. Check for continuity and measure the resistance between No.1 and NO.3 terminals.

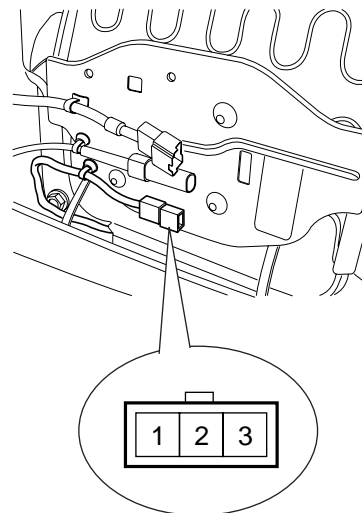

ATIE441D

Standard value: 2.34 ± 10%  
(Cushion: 1.19 ± 10%, Back: 1.15 ± 10%)

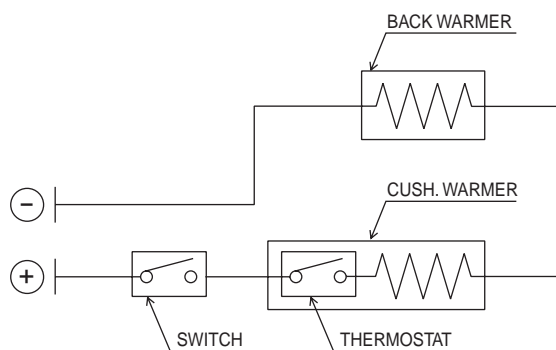

LTGE441C

2. Operate the seat warmer after connecting the 2P connector, and then check for the thermostat by measuring the temperature of seat surface.
3. Check for continuity between the terminals after disconnecting the 3P connector.

Standard value :  
28 ±3.5°C(Continuity), 37 ±3.0 (Short)

# SUNROOF

## COMPONENTS EFEE63D9

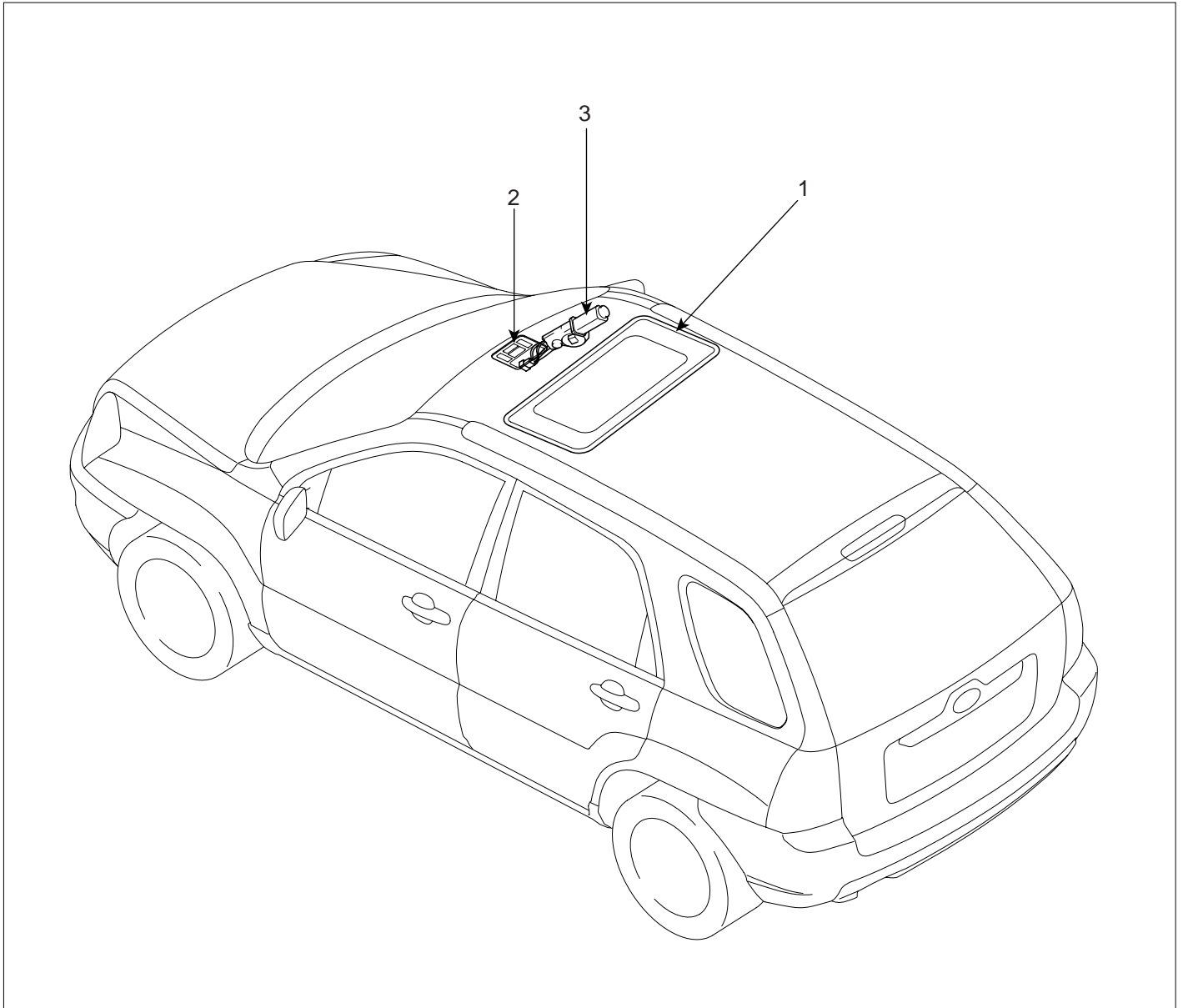

- 1. Sunroof
- 2. Sunroof switch

- 3. Sunroof motor & controller

LTIF480A

CIRCUIT DIAGRAM ED24BFE0

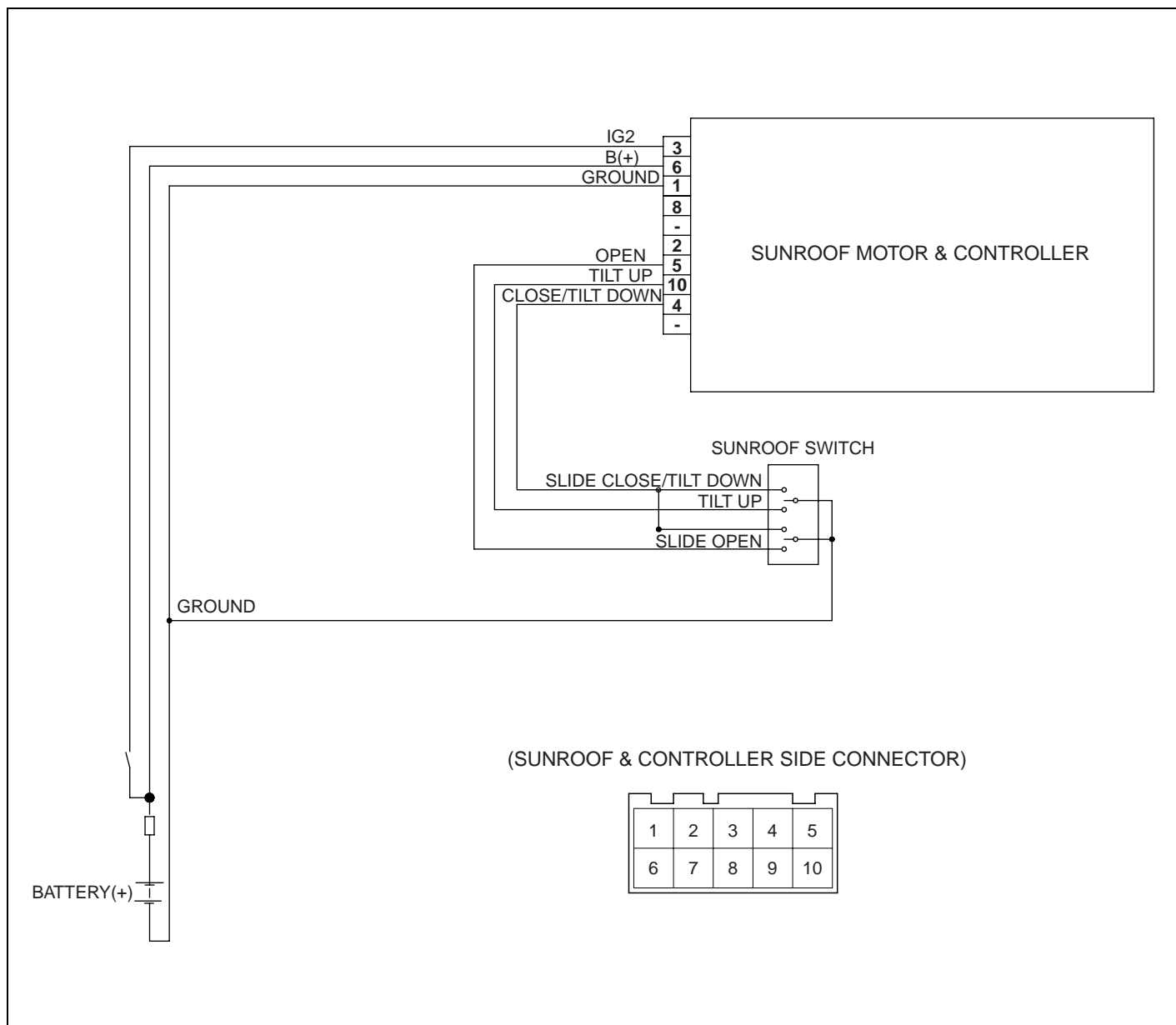

LTIF480B

## SUN ROOF SWITCH

### INSPECTION E83A60F3

1. Disconnect the negative (-) battery terminal.
2. Remove the lens from the overhead console then loose the 2 screws holding the overhead console.

Terminal	2	4	5	6
Slide open	○			○
Slide close	○	○		
Tilt up	○		○	
Tilt down	○	○		

LTCD129C

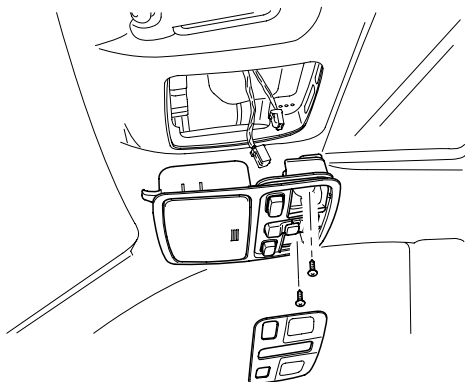

KTQE210G

3. Disconnect the connector (6P) of sunroof switch and the connector (2P) of map lamp then remove the overhead console lamp assembly from the headliner. Check for continuity between the terminals. If the continuity is not as specified, replace the sunroof switch.

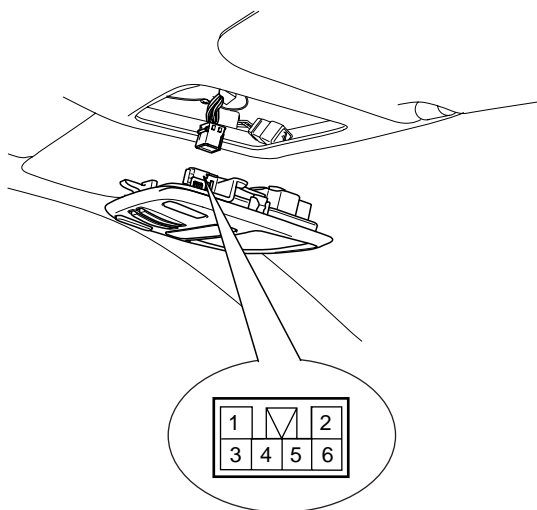

[Switch side connector]

LTIF481B

## SUN ROOF MOTOR

### REPLACEMENT E15C8646

1. Disconnect the negative (-) battery terminal.
2. Remove the lens from the overhead console then loose the 2 screws holding the overhead console.

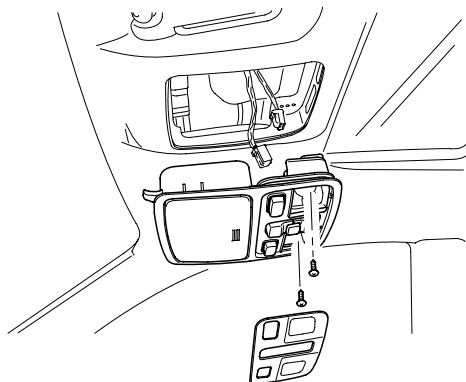

KTQE210G

3. Disconnect the connector (6P) of sunroof switch and the connector (2P) of map lamp then remove the overhead console lamp assembly from the headliner.
4. Remove the sunroof motor (A) after removing 3 screws and disconnect.

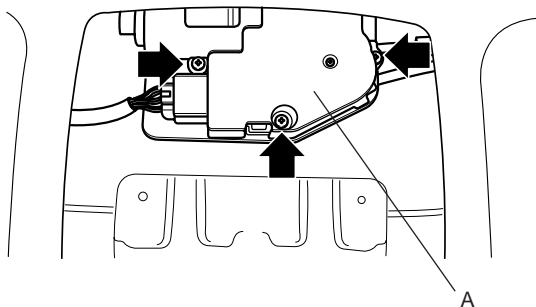

ATGE483A

### INSPECTION E95ABE2E

1. Disconnect the negative (-) battery terminal.
2. Apply the battery voltage to terminal 3, 6 and ground the terminal 1.

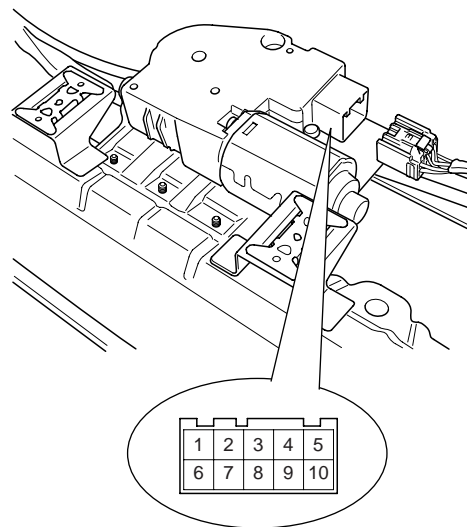

KTQE460A

3. Ground the terminals as below table, and check that the sunroof unit operates as below table.

Function \ Terminal	5	10	4
Tilt up		⊖	
Tilt down			⊖
Slide close			⊖
Slide open	⊖		

LTIF483C

### RESETTING THE SUNROOF E49EBFC7

When your battery happens to be disconnected or discharged, or you use the emergency handle to operate the sunroof, you have to reset your sunroof system as follows.

1. Turn the ignition key to the ON position.
2. In tilt-up position, press the tilt up switch for 3~5 seconds, the slider must be moved 5mm forward and returned original position, then release the switch and let it memorize the initial value of the motor.
3. In above state, press the tilt up switch once again, and hold on until the sunroof system is reset completely by automatically performing the following : Tilt down Slide open Slide close.

# LIGHTING SYSTEM

## COMPONENTS EB338BDB

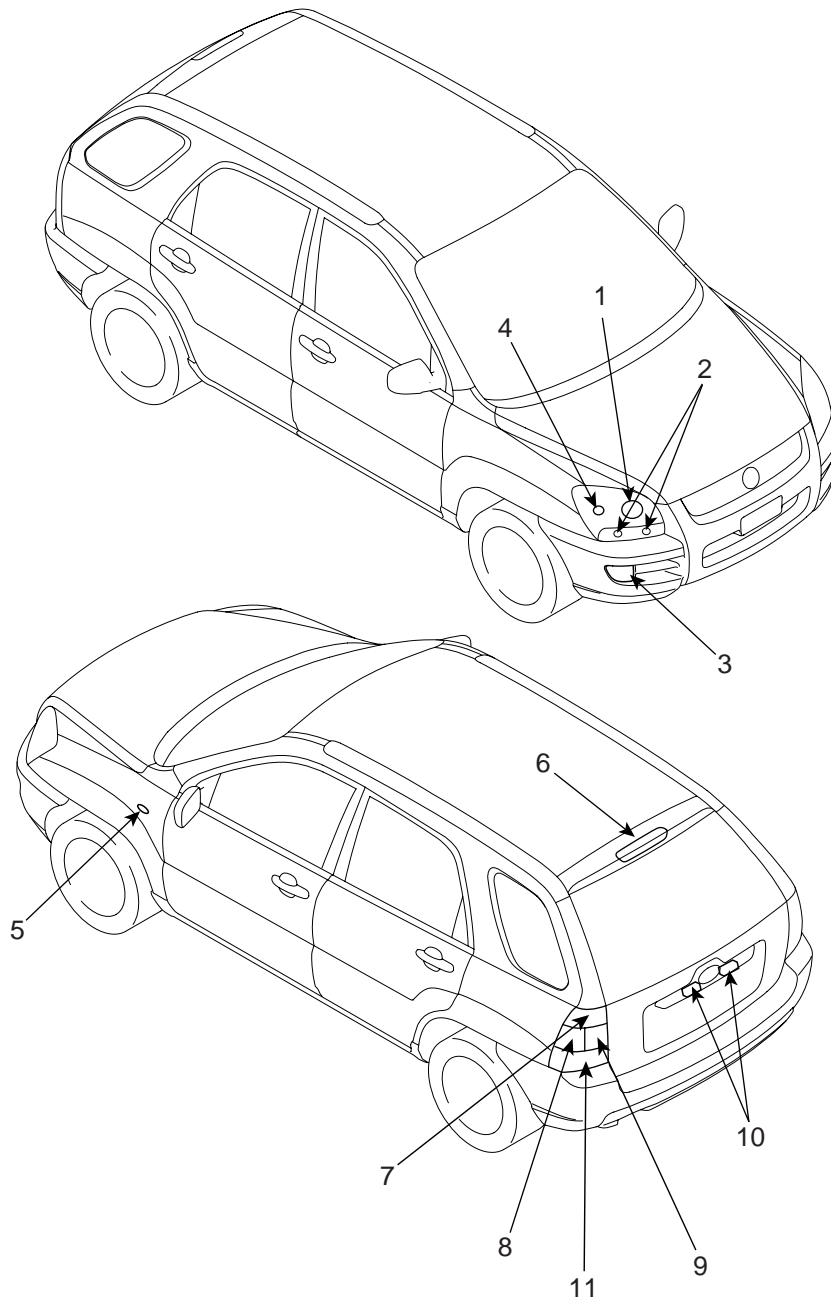

- 1. Head lamp(High/Low)
- 2. Front turn signal lamp
- 3. Front fog lamp
- 4. Position lamp
- 5. Side repeater
- 6. High mounted stop lamp

- 7. Tail/stop lamp
- 8. Rear turn signal lamp
- 9. Back up lamp
- 10. License plate lamp
- 11. Rear fog lamp(Europe)/  
Tail/stop lamp(General)

**LIGHTING SYSTEM**

**BE -145**

**SPECIFICATION** E81FE48B

<b>Items</b>	<b>Bulb Wattage(W)</b>
Head lamp (High/Low)	60/55
Front turn signal lamp	21
Front position lamp	5
Front fog lamp	35
Rear combination lamps	
Tail/stop lamp	21/5
Back up lamp	16
Turn signal lamp	21
Rear fog lamp (Europe)	21
License plate lamp	5
Side repeater	5
Room lamp	10
Overhead console lamp	10 x 2
High mounted stop lamp	LED
Glove box lamp	5
Trunk room lamp	5
Door courtesy lamp	5

## HEAD LAMPS

### REPLACEMENT EC60E036

1. Disconnect the negative (-) battery terminal.
2. Loosen the fastener of radiator grill cover (A) and the mounting bolts.

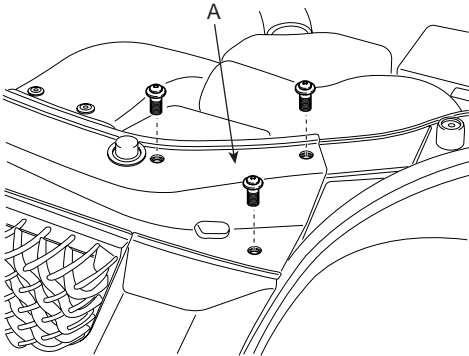

ATIE490B

3. Remove the mounting bar (B) by pulling up after raising the radiator grill cover (A).

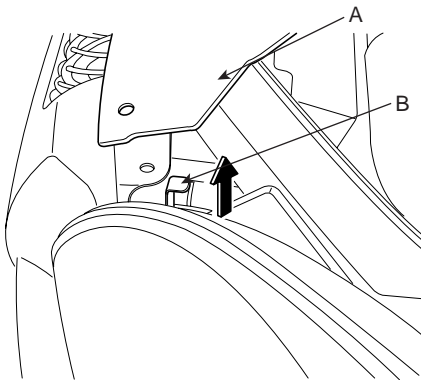

ATIE490C

4. Remove the head lamp assembly after disconnecting the lamp connector.

### NOTE

Take care that holding clip (A) is not to be damaged.

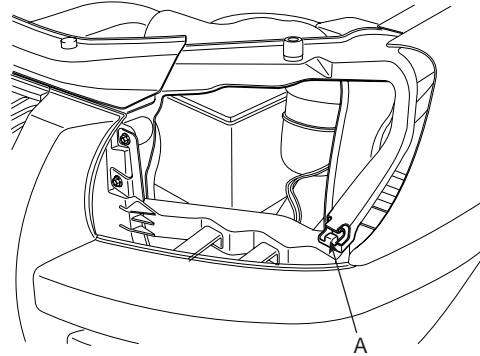

ATIE490D

5. Installation is the reverse of removal.

### HEAD LAMP RELAY INSPECTION EC36770D

1. Pull out the head lamp relay (Low) (A) and head lamp relay (High) (B) from the engine compartment relay box.

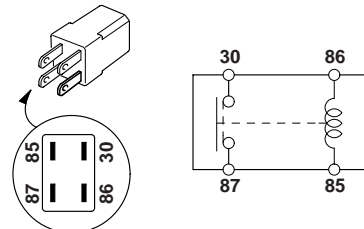
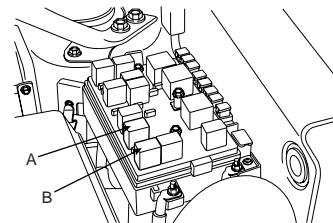

LTIF4911

2. Check for continuity between terminals. There should be continuity between the No.30 and No.87 terminals when power and ground are connected to the No.85 and No.86 terminals

3. There should be no continuity between the No.30 and No.87 terminals when power is disconnected.

Terminal \ Power	30	87	85	86
Disconnected			○ — ○	
Connected	○ — ○		—	+

LTIF221B

**HEAD LAMP AIMING**

**INSTRUCTIONS** E7FCE6A4

The head lamps should be aimed with the proper beam-setting equipment, and in accordance with the equipment manufacturer's instructions.

**NOTE**

*If there are any regulations pertinent to the aiming of head lamps in the area where the vehicle is to be used, adjust so as to meet those requirements.*

Alternately turn the adjusting gear to adjust the head lamp aiming. If beam-setting equipment is not available, proceed as follows :

1. Inflate the tires to the specified pressure and remove any loads from the vehicle except the driver, spare tire, and tools.
2. The vehicle should be placed on a flat floor.
3. Draw vertical lines (Vertical lines passing through respective head lamp centers) and a horizontal line (Horizontal line passing through center of head lamps) on the screen.

4. With the head lamp and battery in normal condition, aim the head lamps so the brightest portion falls on the horizontal and vertical lines. Make vertical and horizontal adjustments to the lower beam using the adjusting wheel.

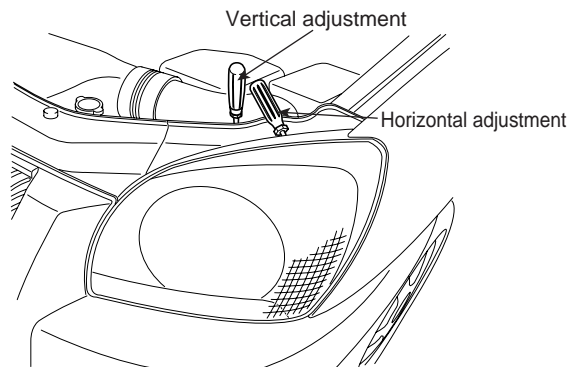

LTIF490E

**FRONT FOG LAMP AIMING**

The front fog lamps should be aimed in the same manner of the head lamps aiming. With the front fog lamps and battery normal condition, aim the front fog lamps by turning the adjusting gear.

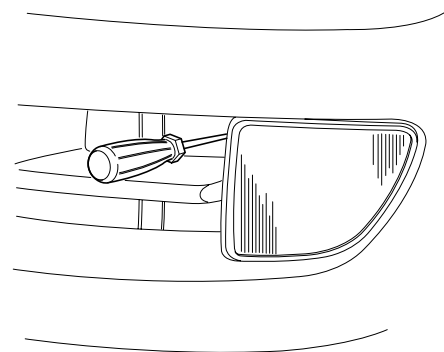

ATIE490F

HEAD LAMP AND FOG LAMP AIMING POINT

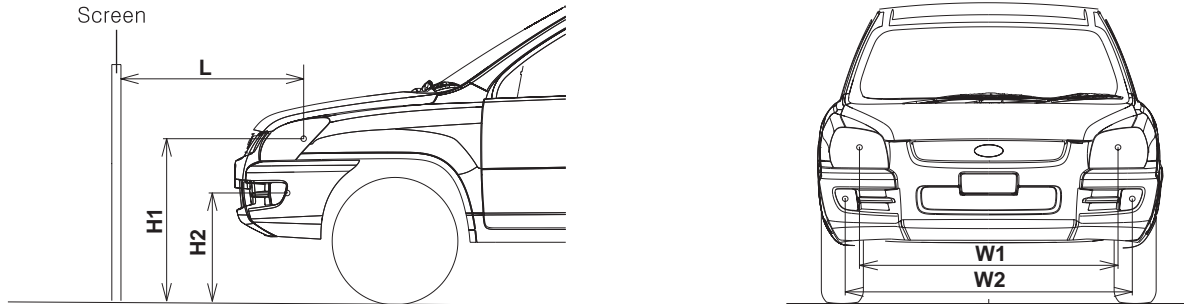

- H1 : Height between the head lamp bulb center and ground(High/low beam)
- H2 : Height between the fog lamp bulb center and ground
- W1 : Distance between the two head lamp bulbs centers(High/low beam)
- W2 : Distance between the two fog lamp bulbs centers
- L : Distance between the head lamp bulb center and screen

LTIF491C

Unit : in(mm)

Vehicle condition	H1	H2	W1	W2	L
Without driver	34.1(866)	22.6(573)	53.5(1,360)	59.4(1,510)	118.1(3,000)
With driver	33.9(862)	22.4(569)			

LTIF491D

1. Turn the low beam on without driver aboard.  
The cut-off line should be projected in the allowable range (shaded region).

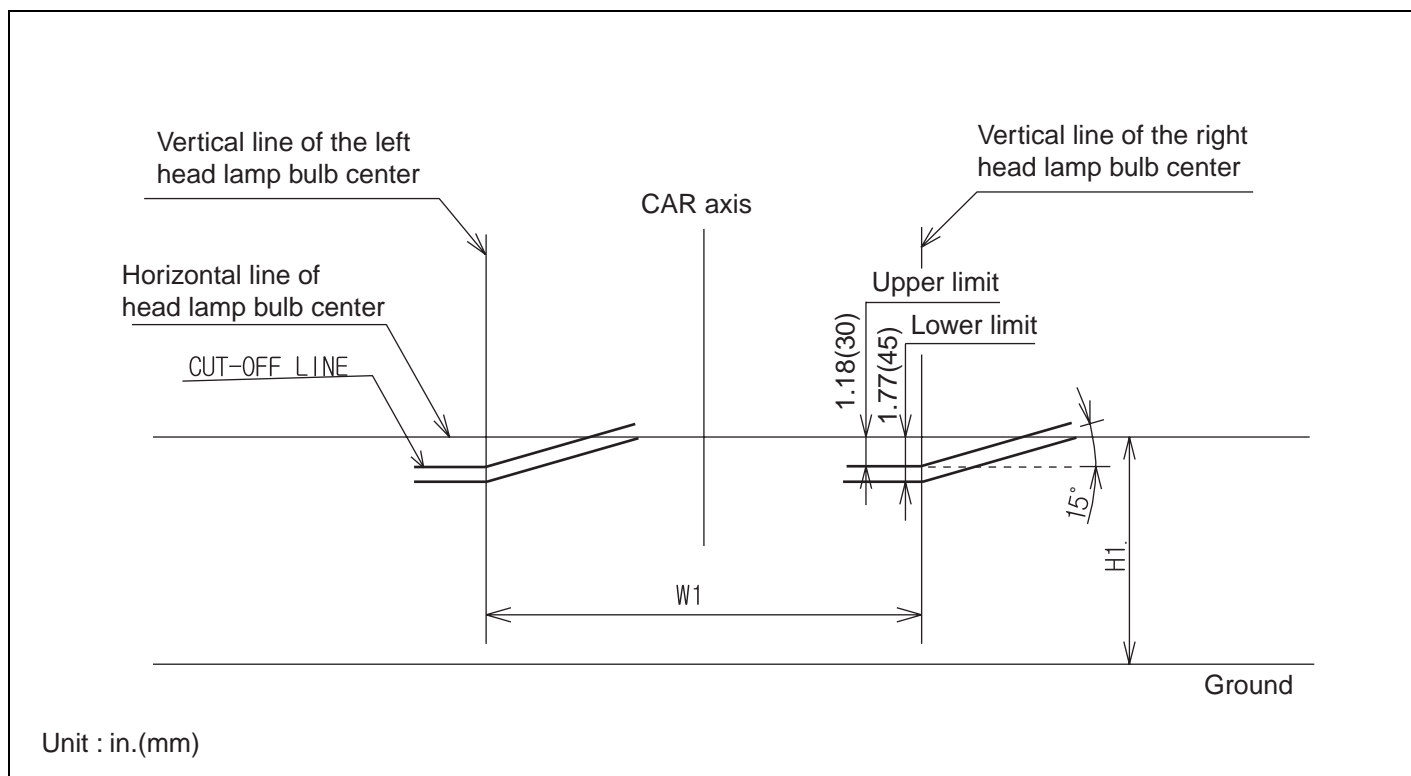

LTIF491E

2. Turn the front fog lamp on without the driver aboard.  
The cut-off line should be projected in the allowable range (shaded region)

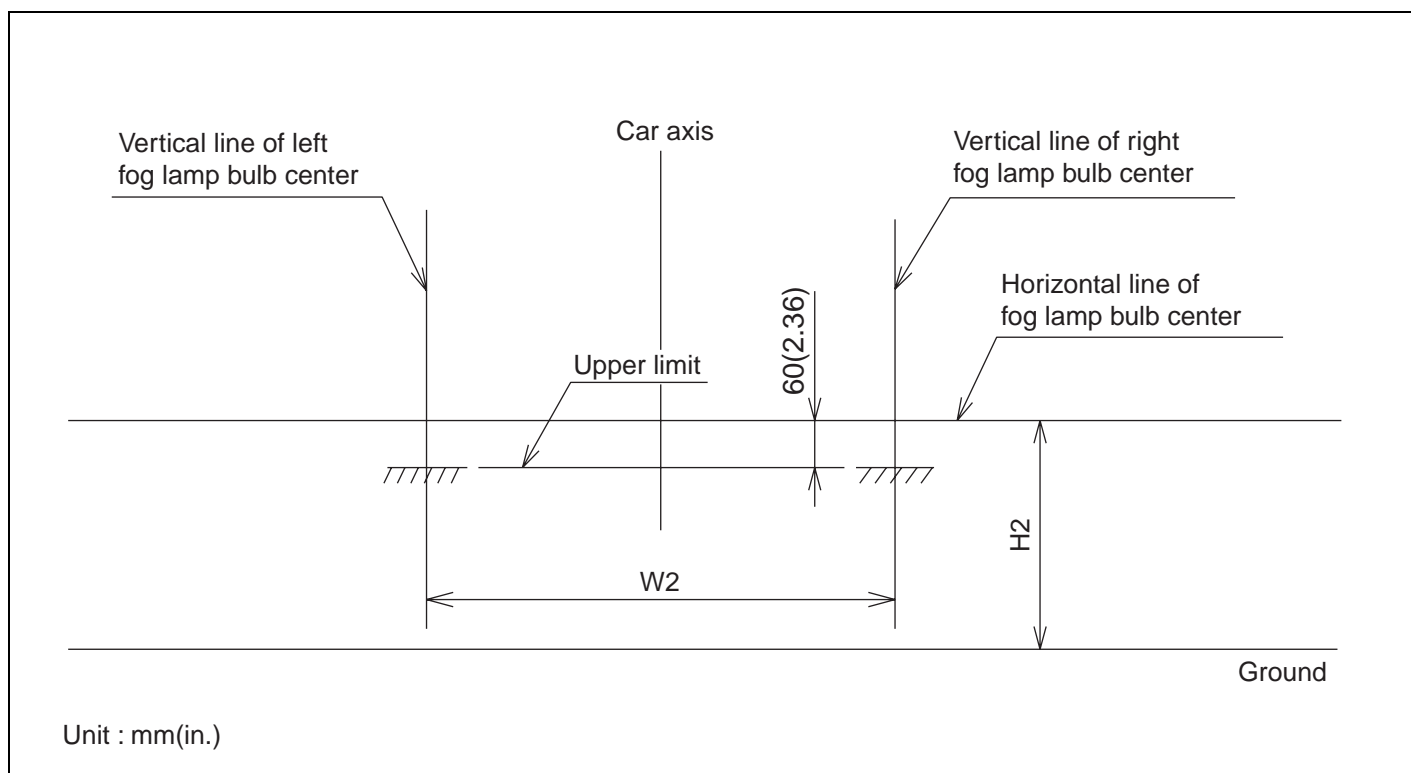

BTGE491G

## TURN SIGNAL LAMP

### REPLACEMENT ECA36B99

1. Disconnect the negative (-) battery terminal.
2. Loosen the screws holding the rear combination lamp then disconnect the 6P connector.

 **NOTE**

*Take care that holding clip (A) is not to be damaged.*

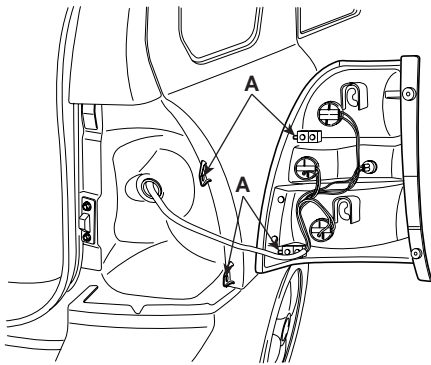

ATIE491J

3. Remove the rear combination lamp and replace the bulbs; stop & tail lamp, turn signal lamp, back up lamp.
4. Installation is the reverse of removal.

**ROOM LAMP**

**REPLACEMENT** EB8BC73D

1. Disconnect the negative (-) battery terminal.
2. Detach the lamp lens from the room lamp with a flat-tip screwdriver then replace the bulb.
3. Remove the room lamp assembly after removing 2 screws and disconnecting the 3P connector.

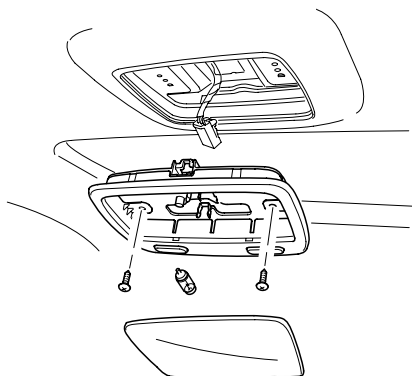

4. Installation is the reverse of removal.

ATIE491K

**INSPECTION** E7FCB4F4

Remove the room lamp assembly then check for continuity between terminals.

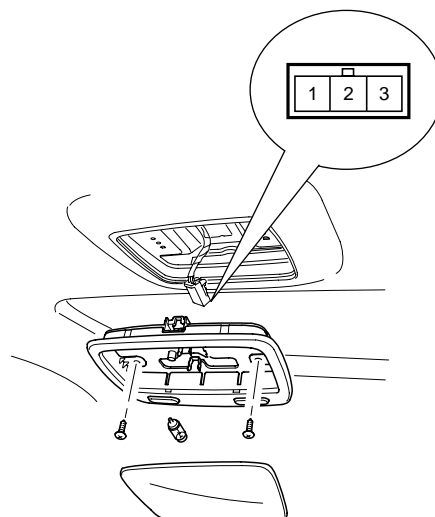

KTQE210F

Terminal / Position	1	2	3
ON		○ — (M) — ○	
DOOR	○ — (M) — ○		
OFF			

LTIF491K

## OVERHEAD CONSOLE LAMP

### REPLACEMENT ECD81DF3

1. Disconnect the negative (-) battery terminal.
2. Remove the lens from the overhead console then loose the 2 screws holding the overhead console.
3. Disconnect the connector (6P) of sunroof switch and the connector (2P) of map lamp then remove the overhead console lamp assembly from the headliner.

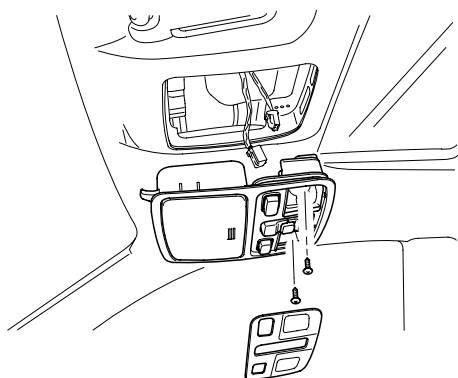

ATIE491L

4. Installation is the reverse of removal.

### INSPECTION E12DEA95

Remove the overhead console lamp assembly then check for continuity between terminals.

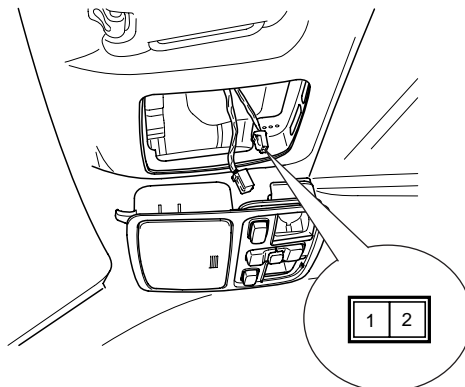

KTQE972A

Terminal	Position	Map lamp switch			
		LH		RH	
		ON	OFF	ON	OFF
1		○		○	
2		○		○	

ETKE007M

**TURN / HAZARD LAMPS**

**INSPECTION** E24DA29C

**HAZARD LAMP SWITCH**

1. Disconnect the negative (-) battery terminal.
2. Remove the hazard lamp switch from the center facia panel and disconnect the 10P connector.

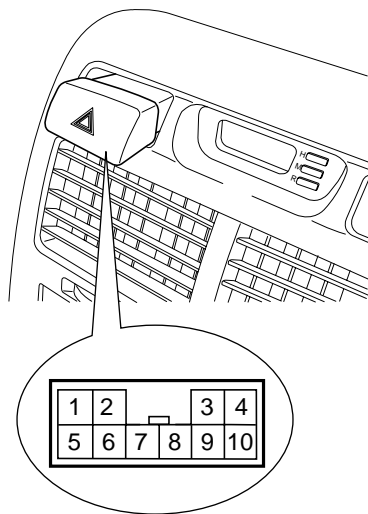

ATIE495A

3. Operate the switch and check for continuity between terminals with an ohmmeter.

Terminal Position	2	3	6	9	10	5	7	8
OFF	○	○				○	—	○
ON	○	○	○	○	○		○	○

Illumination

LTIF491M

**HAZARD LAMP RELAY INSPECTION**

1. Remove the negative (-) battery terminal.
2. Remove the junction box.
3. Check for continuity between the terminals.
4. There should be continuity between the No.1 in the I/P-J terminal and No.11/No.10 in the I/P-G terminal when power and ground are connected to the No.1 in the I/P-J terminal and No.4 in the I/P-C terminal.
5. There should be no continuity between the No.1 in the I/P-J terminal and No.11/No.10 in the I/P-G terminal when power is disconnected.

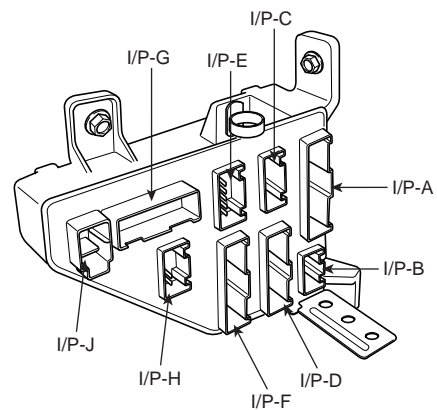

ATIE323A

Terminal Position	I/P-J (1)	I/P-G (11or10)	I/P-C (4)	I/P-J (1)
Disconnected			○	○
Connected	○	○	⊖	⊕

LTIF495C

## FLASHER UNIT

### INSPECTION

E2B7E8C4

1. Disconnect the negative (-) battery terminal.
2. Disconnect the hood release cable from the hood release handle
3. Remove the lower crash pad panel (A).

#### Fastener Locations

▶ : Screw, 3

▷ : Clip, 5

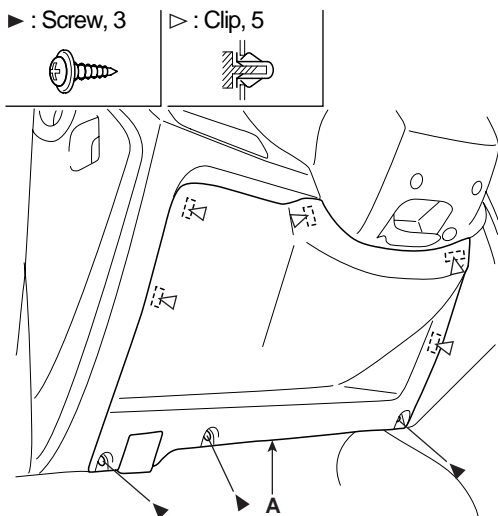

LSIE022D

4. Remove the flasher unit (A) after loosening the nut and disconnecting the connector.

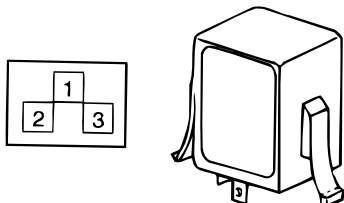
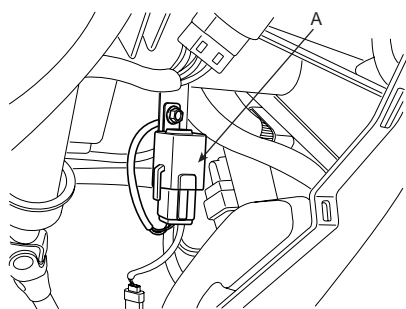

LTIF495E

5. Connect the positive (+) lead from the battery to terminal 2 and the negative (-) lead to terminal 3.

6. Connect the two turn signal lamps in parallel to terminals 1 and 3. Check that the bulbs turn on and off.



### NOTE

The turn signal lamps should flash 60 to 120 times per minute. If one of the front or rear turn signal lamps has an open circuit, the number of flashes will be more than 120 per minute. If operation is not as specified, replace the flasher unit.

**FRONT FOG LAMPS**

**REPLACEMENT** E0DEDF47

1. Disconnect the negative (-) battery terminal.
2. Remove the front bumper.  
(Refer to the BD group - front bumper).
3. Remove the front fog lamp (A) after loosening the screws and disconnecting the fog lamp connector.



ATIE495F

4. Installation is the reverse of removal.

**FRONT FOG LAMP RELAY INSPECTION** E63AC225

1. Pull out the front fog lamp (A) relay from the engine compartment relay box.
2. Check for continuity between terminals. There should be continuity between the No.30 and No.87 terminals when power and ground are connected to the No.85 and No.86 terminals.
3. There should be no continuity between the No.30 and No.87 terminals when power is disconnected.

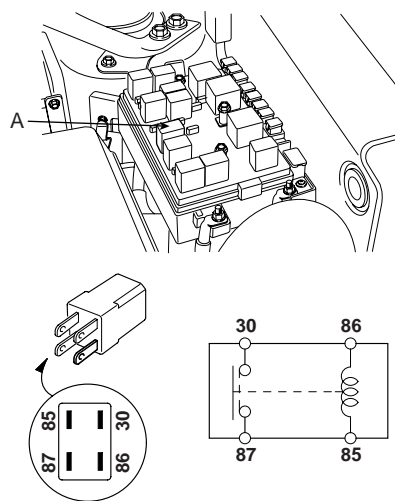

ATIE496A

Terminal	30	87	85	86
Power				
Disconnected			○ — ○	○ — ○
Connected	○ — ○	○ — ○	⊖ — ⊕	⊖ — ⊕

LTIF221B

## REAR FOG LAMPS

### INSPECTION E2C7369D

#### REAR FOG LAMP SWITCH

1. Disconnect the negative (-) battery terminal.
2. Remove the rear fog lamp switch (A) from the center facia panel and disconnect the 6P connector.

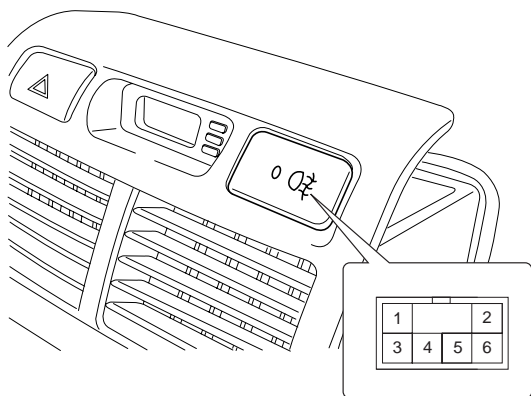

LTIF497A

3. Check for continuity between the terminals in each switch position according to the table.

Terminal Position	2	5	1	4	3	6
ON						
OFF						

LTIF497B

#### REAR FOG LAMP RELAY

1. Remove the negative (-) battery terminal.
2. Remove the ICM (Integrated circuit module) relay.
3. Check for continuity between the terminals.
4. There should be continuity between the No.9 in the M37-1 and No.4 in the M37-2 terminals when power and ground are connected to the No.1 in the M37-1 and No.3 in the M37-2 terminals.
5. There should be continuity between the No.9 in the M37-1 and No.10 in the M37-2 terminals when power and ground are disconnected to the No.1 in the M37-1 and No.3 in the M37-2 terminals.

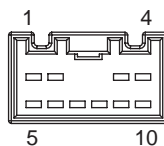
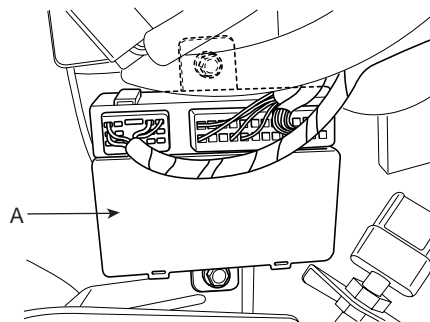

[M37-2]

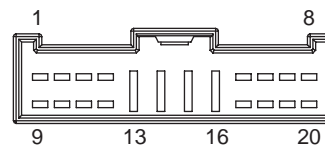

[M37-1]

ATIE220F

## LICENSE LAMPS

### REPLACEMENT EF9B5292

1. Disconnect the negative (-) battery terminal.
2. Remove the license plate lamp after removing 2 screws and lens (A).

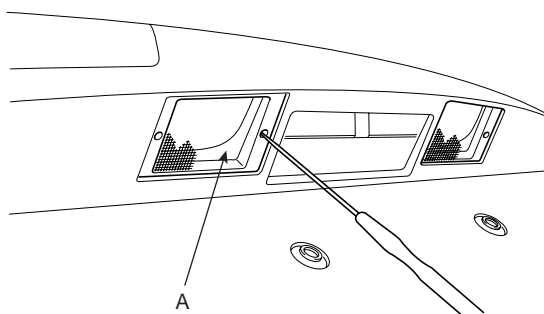

ATIE498A

3. Replace the bulb.
4. Installation is the reverse of removal.

## STOP LAMPS

### HIGH MOUNTED STOP LAMP

#### REPLACEMENT E7E95CBF

1. Disconnect the negative (-) battery terminal.
2. Open the tail gate and then loose the mounting nuts.
3. Remove the high mounted stop lamp after disconnecting the connector of high mounted stop lamp.

 **NOTE**

*Take care that holding clip (A) is not to be damaged.*

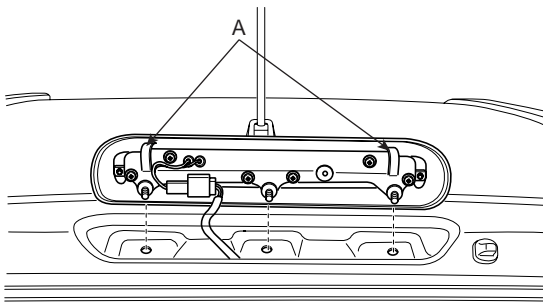

ATIE499A

4. Installation is the reverse of removal.

## TRUNK LAMPS

### REPLACEMENT ED8DF06D

1. Disconnect the negative (-) battery terminal.
2. Detach the lamp lens from the trunk room lamp with a flat-tip screwdriver then replace the bulb.
3. Remove the trunk room lamp assembly after removing 2 screws and disconnecting the 3P connector.

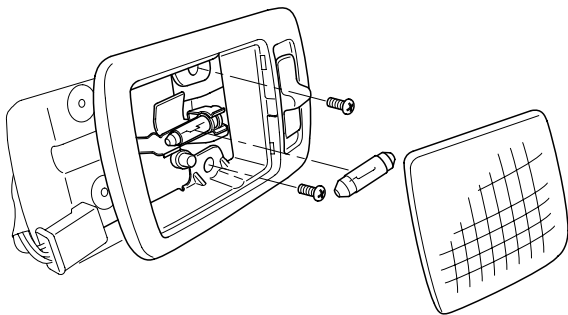

ATIE499B

4. Installation is the reverse of removal.

# AUTO LIGHTING CONTROL SYSTEM

## COMPONENTS ED5CDC5A

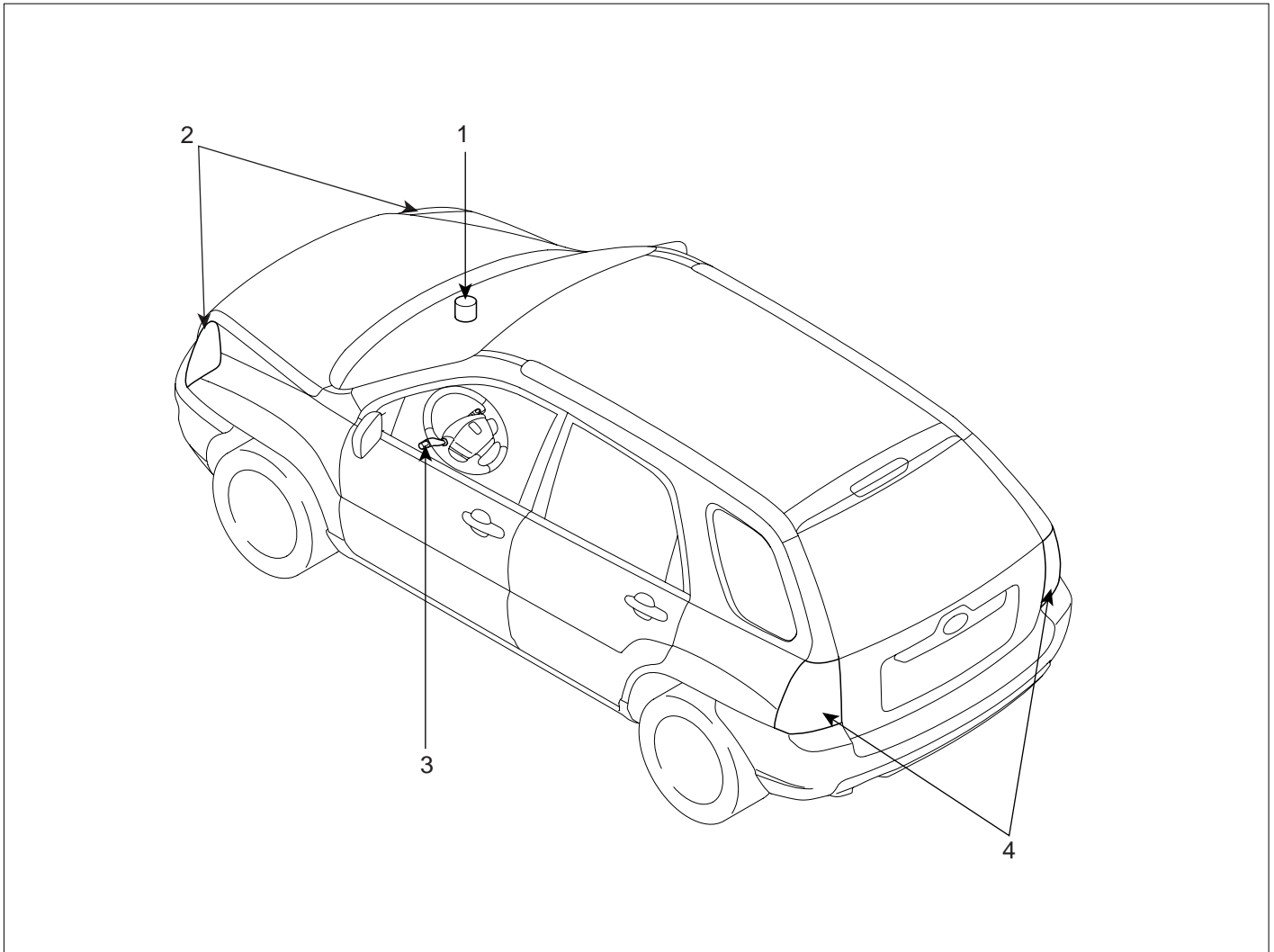

1. Auto light unit  
2. Head lamps

3. Lighting switch (Auto)  
4. Tail lamps

LTIF510A

## AUTO LIGHTING CONTROL SYSTEM

BE -161

### DESCRIPTION E7DFDBC0

The auto light control system operates by using the auto light switch.

If you set the multi-function switch to "AUTO" position, the tail lamp and head lamp will be turned automatically on or off according to external illumination.

### SPECIFICATIONS EC3C3D7B

Items	Specifications
Rated voltage	12V
Load	Max. 200mA (Relay load)
Detection illuminations Tail lamp / Head lamp	ON : 24 ± 5.2 (Lux), 0.81 ±0.05 (V) OFF : 48 ± 10.5 (Lux), 1.41 ±0.05 (V)

CIRCUIT DIAGRAM EB3FA244

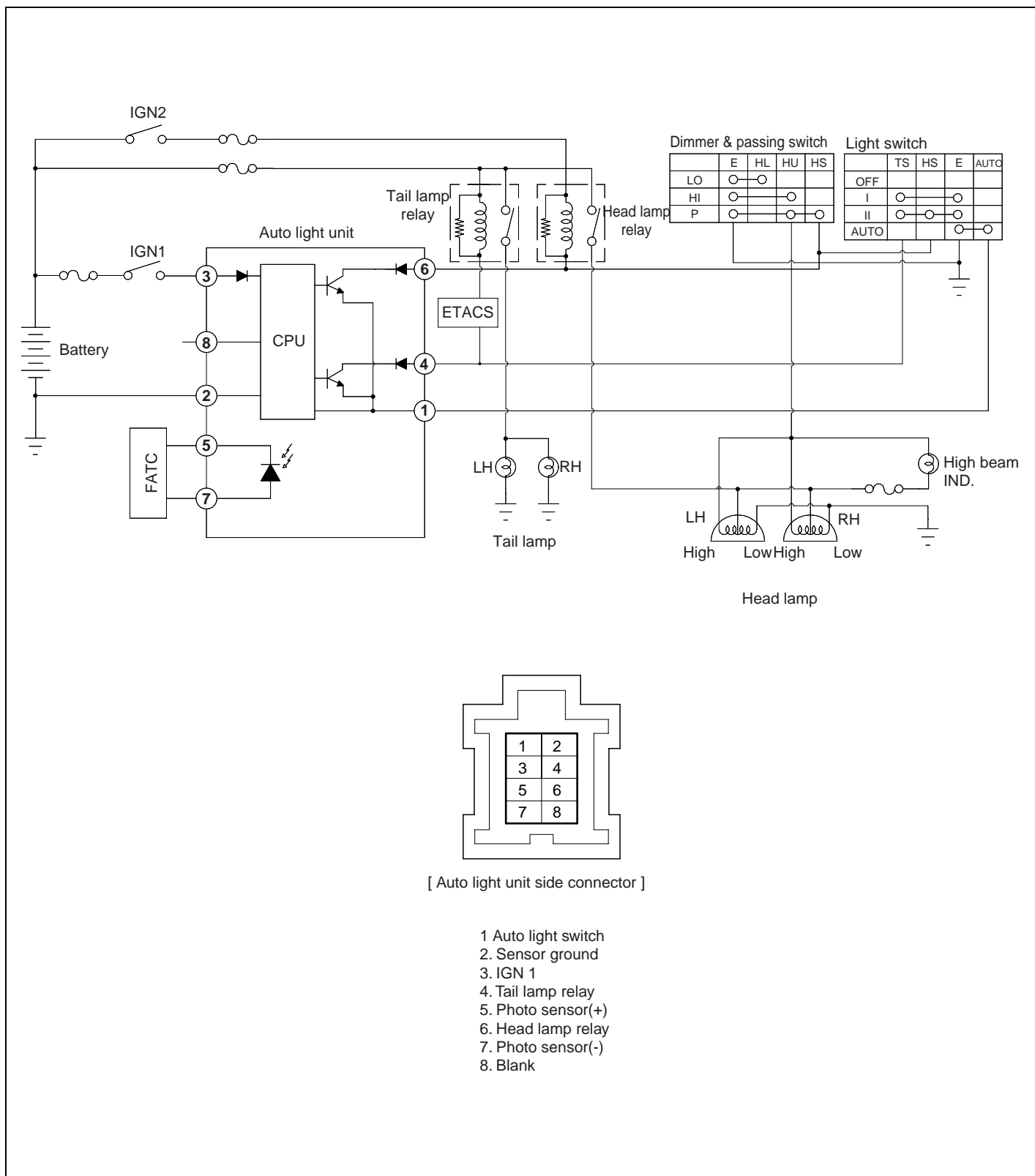

**AUTO LIGHT CONTROL MODULE**

**AUTO LIGHT SENSOR INSPECTION** EF091B01

1. Remove the photo & auto light sensor (A) after removing the defroster center cover from upper the crash pad.

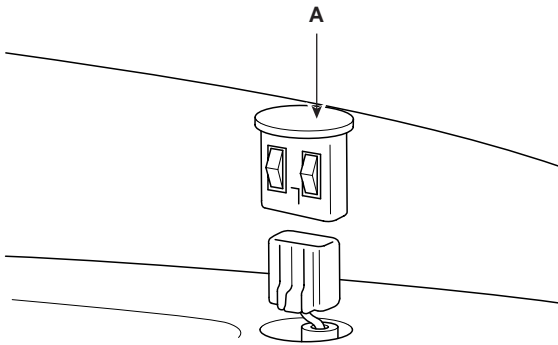

ATIE510B

2. Disconnect the 8P connector from the auto light sensor then inspect the connector on the wire harness side, as shown in the chart.

Tester connection	Condition	Specified condition
1-Ground	Auto light switch ON	Continuity
2-Ground	Constant	Continuity
3-Ground	Ignition switch ON	12V
4-Ground	Constant	5V
	Tail lamp switch ON	0V
6-Ground	Ignition switch ON	12V
	Head lamp switch ON	0V

3. If the circuit is not as specified, inspect the circuits connected to other parts.

## AUTO LIGHT SWITCH

### INSPECTION EC14FFD1

Operate the auto light switch, and then check for continuity between terminals of 18P multi-function switch connector.

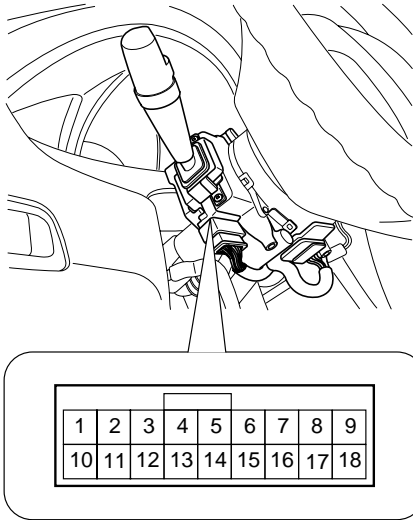

ATIE031E

Terminal Position	14	15	16	17
OFF				
I	○	—————		○
II	○	○	—————	○
AUTO			○	○

LTGE031E

# DAYTIME RUNNING LIGHTS

## CIRCUIT DIAGRAM EB49F300

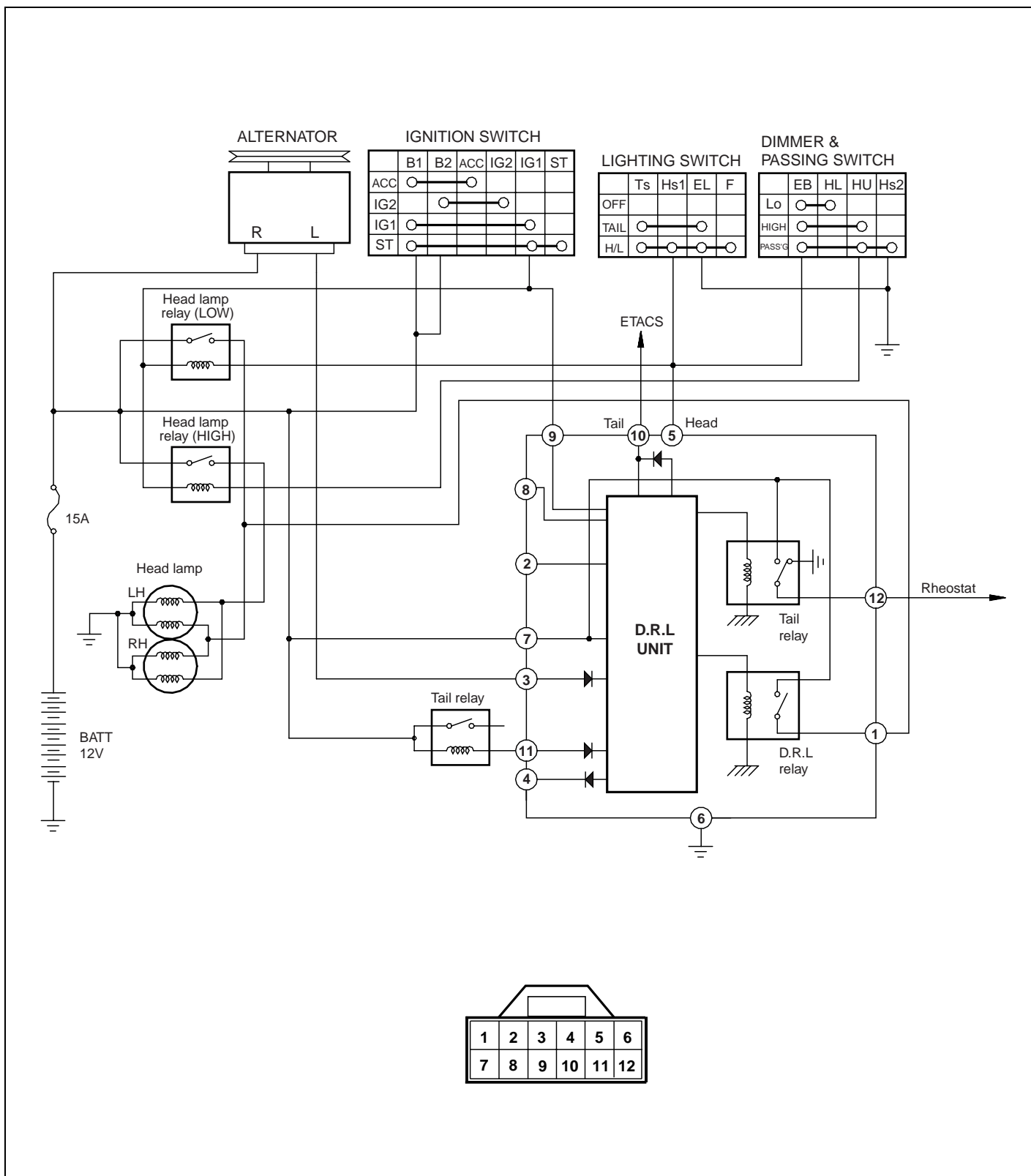

**INSPECTION** E20D3A10

- Daytime running unit (A) is installed at the right side strut housing.

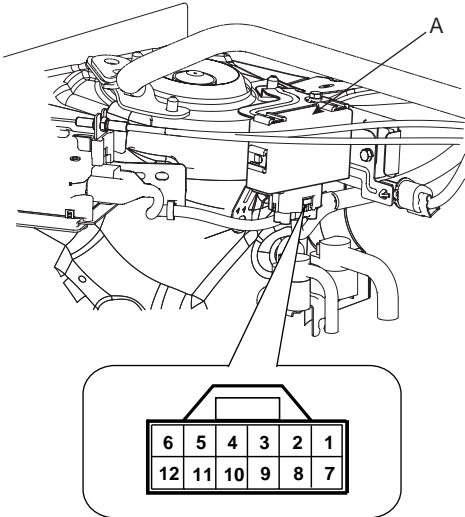

[ DRL module harness side connector ]

LTIF521A

- Check that the light operate according to the following timing chart.

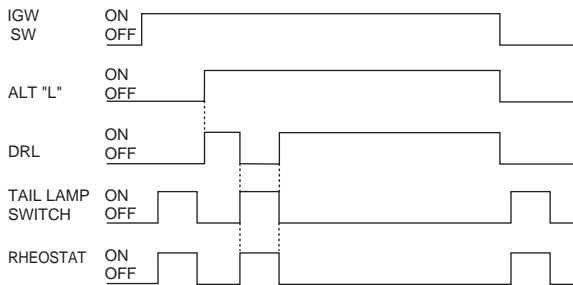

LTHE521A

- Inspect the connector and terminals to be sure they are all making good contact. If the terminals are bent, loose or corroded, repair them as necessary, and recheck the system. If the terminals look OK, go to step 4.

- Make these input tests at the connector  
If any test indicates a problem, find and correct the cause, then recheck the system.  
If all the input tests prove OK, the control unit must be faulty; replace it.

Ter- minal	Test condition	Test: Desired result
1	Headlight ON	Check for voltage to ground: There should be battery voltage.
2	Blank	-
3	Engine running	Check for voltage to ground: There should be battery voltage.
4	Blank	-
5	IG1	Check for voltage to ground: There should be battery voltage.
6	Under all conditions	Check for voltage to ground: There should be continuity.
7	Under all conditions	Check for voltage to ground: There should be battery voltage.
8	Blank	-
9	IG1	Check for voltage to ground: There should be battery voltage.
10	Under all conditions	Check for voltage to ground: There should be battery voltage.
11	Under all conditions	Check for voltage to ground: There should be battery voltage.
12	Under all conditions	Check for voltage to ground: There should be continuity.

# HEAD LAMP LEVELING DEVICE

COMPONENTS E583ECE9

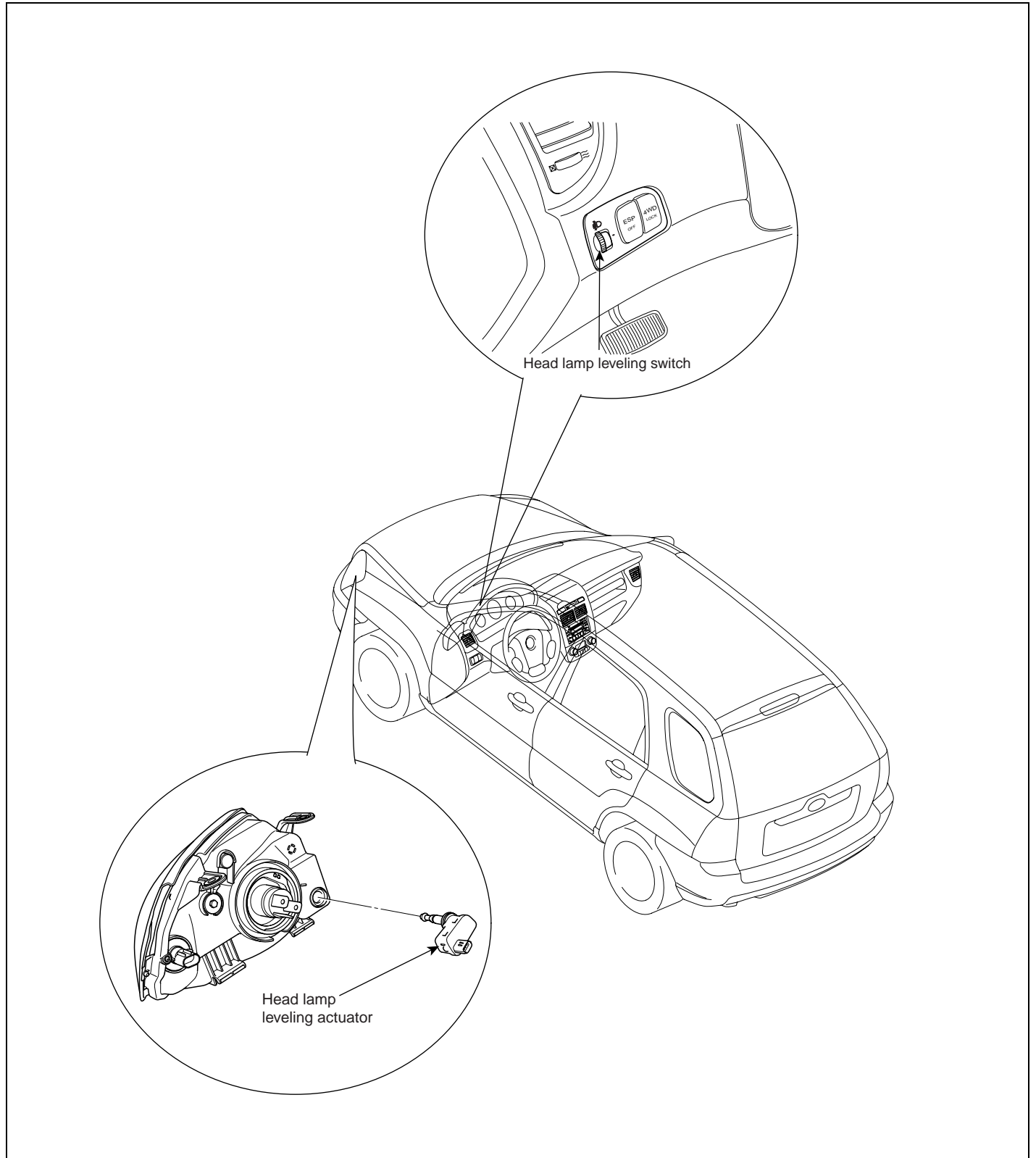

## HEAD LAMP LEVELING ACTUATOR

### REPLACEMENT E5FEEF13

1. Disconnect the negative (-) battery terminal.
2. Remove the head lamp assembly (Refer to the head lamp).
3. Remove the head lamp leveling actuator (A) by loosening the adjusting bolt (B) after rotating it to an arrow direction.

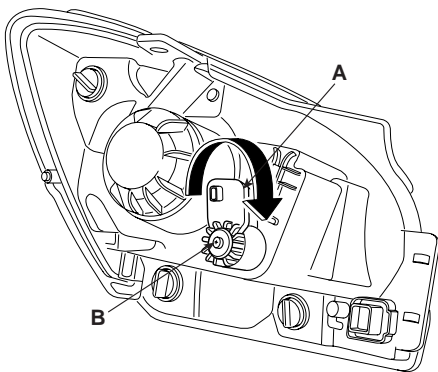

LTIF541A

4. Installation is the reverse of removal procedure.

## HEAD LAMP LEVELING SWITCH

### INSPECTION E442DD7C

1. Disconnect the negative (-) battery terminal.
2. Remove the head lamp leveling switch (A) from the side crash pad and disconnect the 5P connector by using the scraper.

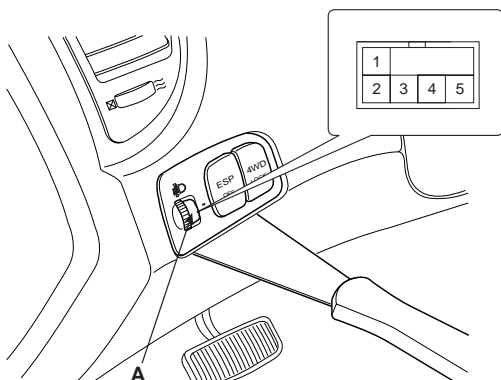

LTIF542B

3. Connect the battery voltage between terminals 5 and 4(Reference voltage=  $V_b$ ).
4. Measure the voltage between terminals 3 and 4(V) at each position.

Position No.	Rotation	Voltage (V)
0	0°	10.80 ± 0.5V
1	20°	8.67 ± 0.5V
2	40°	7.30 ± 0.5V
3	60°	5.92 ± 0.5V

5. If the voltage is not as specified, replace the head lamp leveling switch.

CIRCUIT DIAGRAM EEE5981D

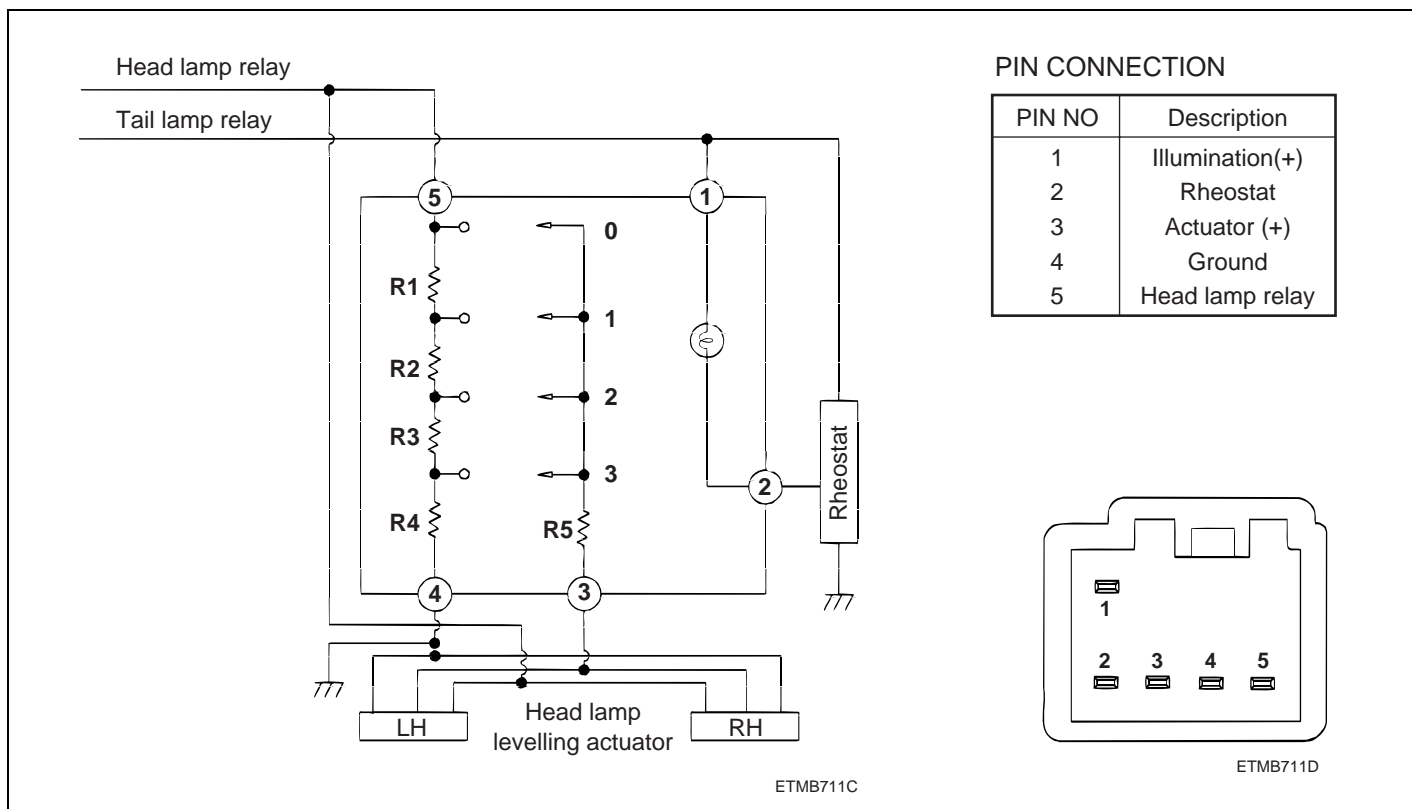

LTIF542A

# IMMOBILIZER CONTROL SYSTEM

## DESCRIPTION E052A04B

The immobilizer system will disable the vehicle unless the proper ignition key is used, in addition to the currently available anti-theft systems such as car alarms, the immobilizer system aims to drastically reduce the rate of auto theft.

There are two types of immobilizer.

One is a "SMARTRA (SMART TRAnsponder Antenna)" type and another is a "shinchang" type.

### 1. SMARTRA type immobilizer

- The "SMARTRA" type immobilizer system is applied to the D2.0 engine and 2.0 engine.
- The SMARTRA system consists of a transponder located in the ignition key, a antenna coil, a SMARTRA unit (A), an indicator light and the ECM.
- The SMARTRA communicates to the ECM (Engine Control Module) via a dedicated communications line. Since the vehicle engine management system is able to control engine mobilization, it is the most suitable unit to control the SMARTRA.

- When the key is inserted in the ignition and turned to the ON position, the antenna coil sends power to the transponder in the ignition key. The transponder then sends a coded signal back through the SMARTRA unit to the ECM.
- If the proper key has been used, the ECM will energize the fuel supply system. The immobilizer indicator light in the cluster will simultaneously come on for more than five seconds, indicating that the SMARTRA unit has recognized the code sent by the transponder.
- If the wrong key has been used and the code was not received or recognized by the ECM the indicator light will continue blinking for about five seconds until the ignition switch is turned OFF.
- If it is necessary to rewrite the ECM to learn a new key, the dealer needs the customer's vehicle, all its keys and the Hi-scan (pro) equipped with an immobilizer program card. Any key that is not learned during rewriting will no longer start the engine.
- The immobilizer system can store up to four key codes.
- If the customer has lost his key, and cannot start the engine, contact HMC motor service station.

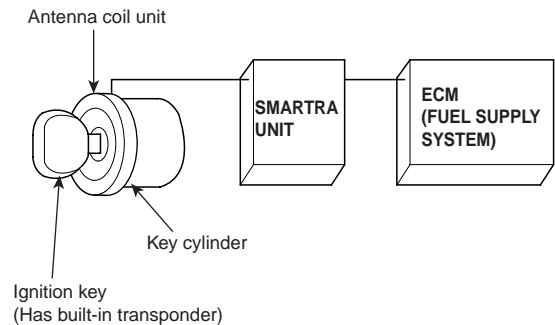
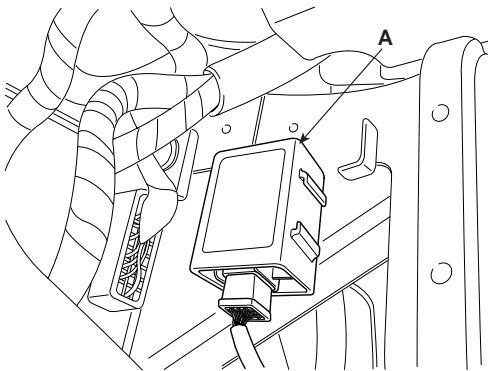

LTIF740G

LTIF740B

2. Shinchang type immobilizer

- The "Shinchang " type immobilizer system is applied to the 2.7 engine.
- The shinchang system consists of a transponder located in the ignition key, a antenna coil, an ICU (Immobilizer control unit), an indicator light and the ECM.
- When the key is inserted in the ignition and turned to the ON position, the antenna coil sends power to the transponder in the ignition key. The transponder then sends a coded signal back through the antenna coil to the ICU (A).

- If it is necessary to rewrite the ICU to learn a new key, the dealer needs the customer's vehicle, all its keys and the Hi-scan (pro) equipped with an immobilizer program card. Any key that is not learned during rewriting will no longer start the engine.
- The immobilizer system can store up to four key codes.
- If the customer has lost his key, and cannot start the engine, contact KMC motor service station.

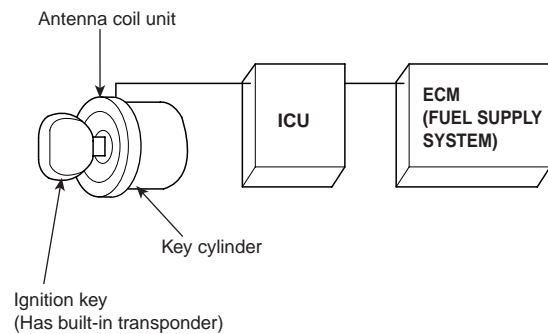
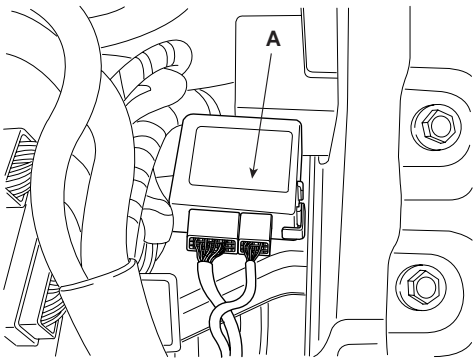

LTIF740C

LTIF740H

- If the ID code transmitted from the key does not match the pre-registered code in the ICU, injection is not performed by the engine ECM. Hence, each vehicle has a set of keys containing a unique ID code which are registered on the ICU. This signal is captured by the antenna coil located in the front section of the steering handle lock and transmitted to the ICU. The ICU analyses and verifies the signal to determine if the signal matches the pre-registered code. If the signal is verified, the ICU transmits a message to the engine ECM to allow injection. The immobilizer indicator light in the cluster will simultaneously come on for more than five seconds, indicating that the ICU has recognized the code sent by the transponder. If the signal is not verified by the ICU, fuel injection is not performed by the engine ECM. The indicator light will continue blinking for five seconds until the ignition switch is turned OFF. Communication between ICU and ECM communicates through the K-line of ECM. K-line is also used for the Communication between ECM and scan tool. There is a relay inside of ICU to switch the communication.

**COMPONENTS OPERATIONS**

E5DC9FAA

**ECM (ENGINE CONTROL MODULE)**

1. SMARTRA type immobilizer  
The ECM carries out a check of the ignition key using a special encryption algorithm, which is programmed into the transponder as well as the ECM simultaneously. Only if the results are equal, the engine can be started. The data of all transponders, which are valid for the vehicle, are stored in the ECM.

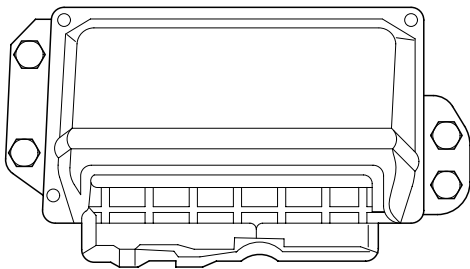

LTIF740D

2. Shinchang type immobilizer  
In the Ignition ON position, the engine ECM receives information from the ICU and permits injection to take place.

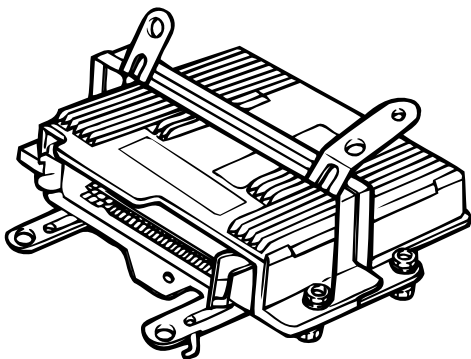

B6BE710E

**ICU (IMMOBILIZER CONTROL UNIT)**

The ICU carries out communication with the built-in transponder in the ignition key. This wireless communication runs on RF (Radio frequency of 125 kHz). The ICU is mounted at the behind of the crush pad under panel close to the antenna coil for RF transmission and receiving. The ICU carries out a check of the ignition key using a special encryption algorithm, which is programmed into the transponder as well as the ICU simultaneously. Only if the results are equal, transmits the signal to the ECM to permits injection. The data of all transponders, which are valid for the vehicle, are stored in the ICU.

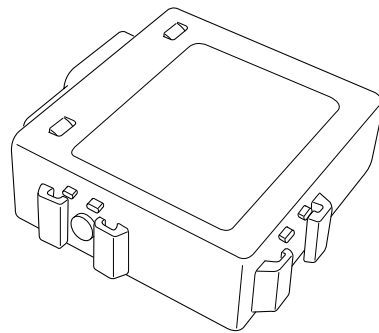

LTIF740E

### SMARTRA UNIT

The SMARTRA carries out communication with the built-in transponder in the ignition key. This wireless communication runs on RF (Radio frequency of 125 kHz). The SMARTRA is mounted at the behind of the crush pad under panel close to the antenna coil for RF transmission and receiving.

The RF signal from the transponder, received by the antenna coil, is converted into messages for serial communication by the SMARTRA device. And, the received messages from the ECM are converted into an RF signal, which is transmitted to the transponder by the antenna.

The SMARTRA does not carry out the validity check of the transponder or the calculation of encryption algorithm. This device is only an advanced interface, which converts the RF data flow of the transponder into serial communication to the ECM and vice versa.

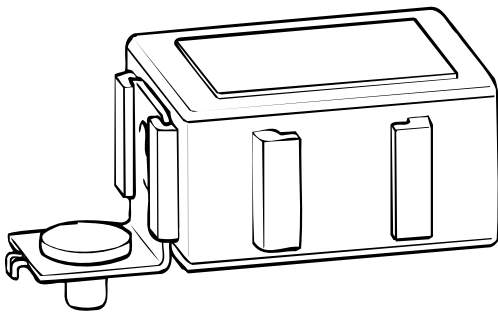

ETNB291C

### TRANSPONDER (BUILT-IN KEYS)

The transponder has an advanced encryption algorithm. During the key teaching procedure, the transponder will be programmed with vehicle specific data. The vehicle specific data are written into the transponder memory. The write procedure is once only; therefore, the contents of the transponder can never be modified or changed.

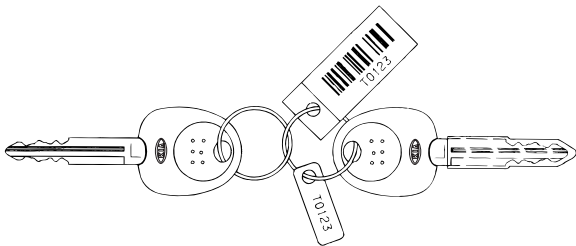

LTIF740I

### ANTENNA COIL

The antenna coil (A) has the following functions.

- The antenna coil supplies energy to the transponder.
- The antenna coil receives signal from the transponder.
- The antenna coil sends transponder signal to the SMARTRA/ICU.

It is located directly in front of the steering handle lock.

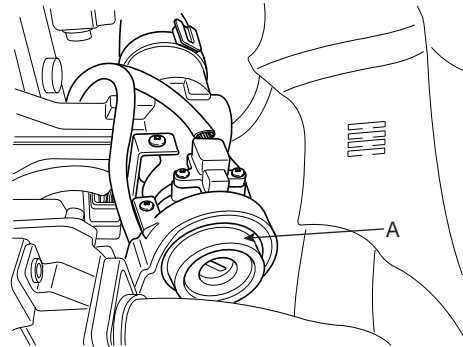

LTIF740F

SYSTEM BLOCK DIAGRAM E7E9977A

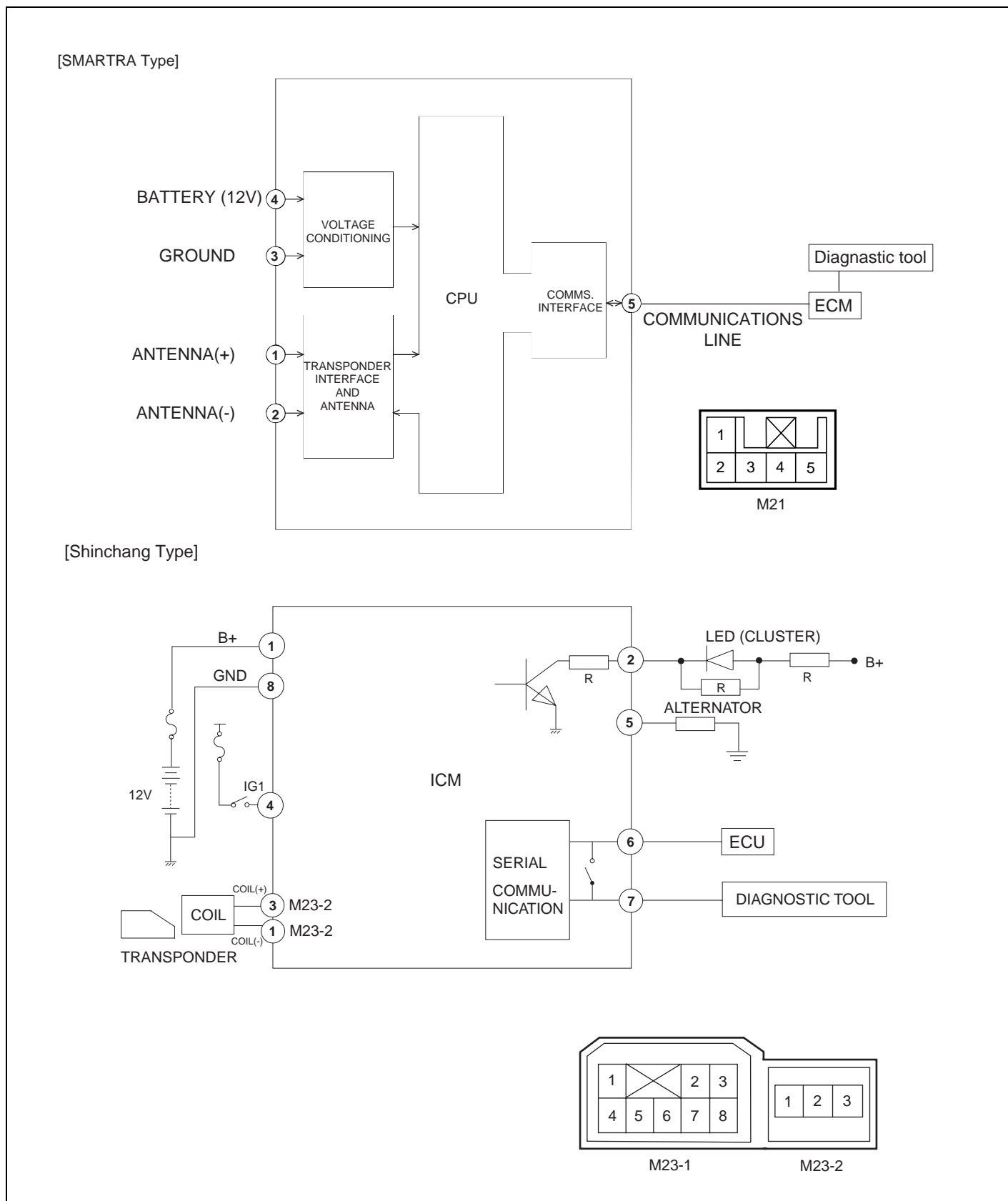



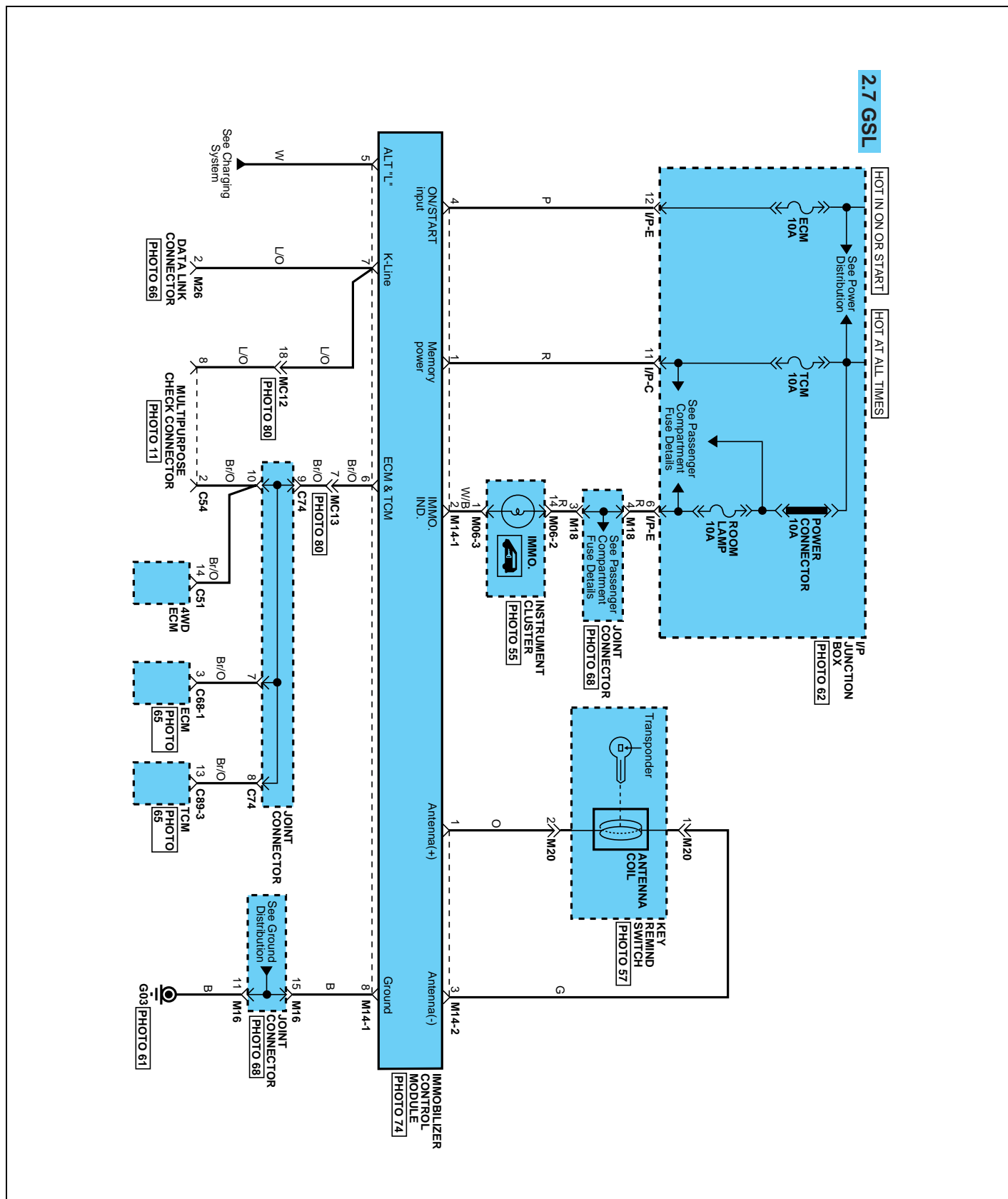

LTIF740K

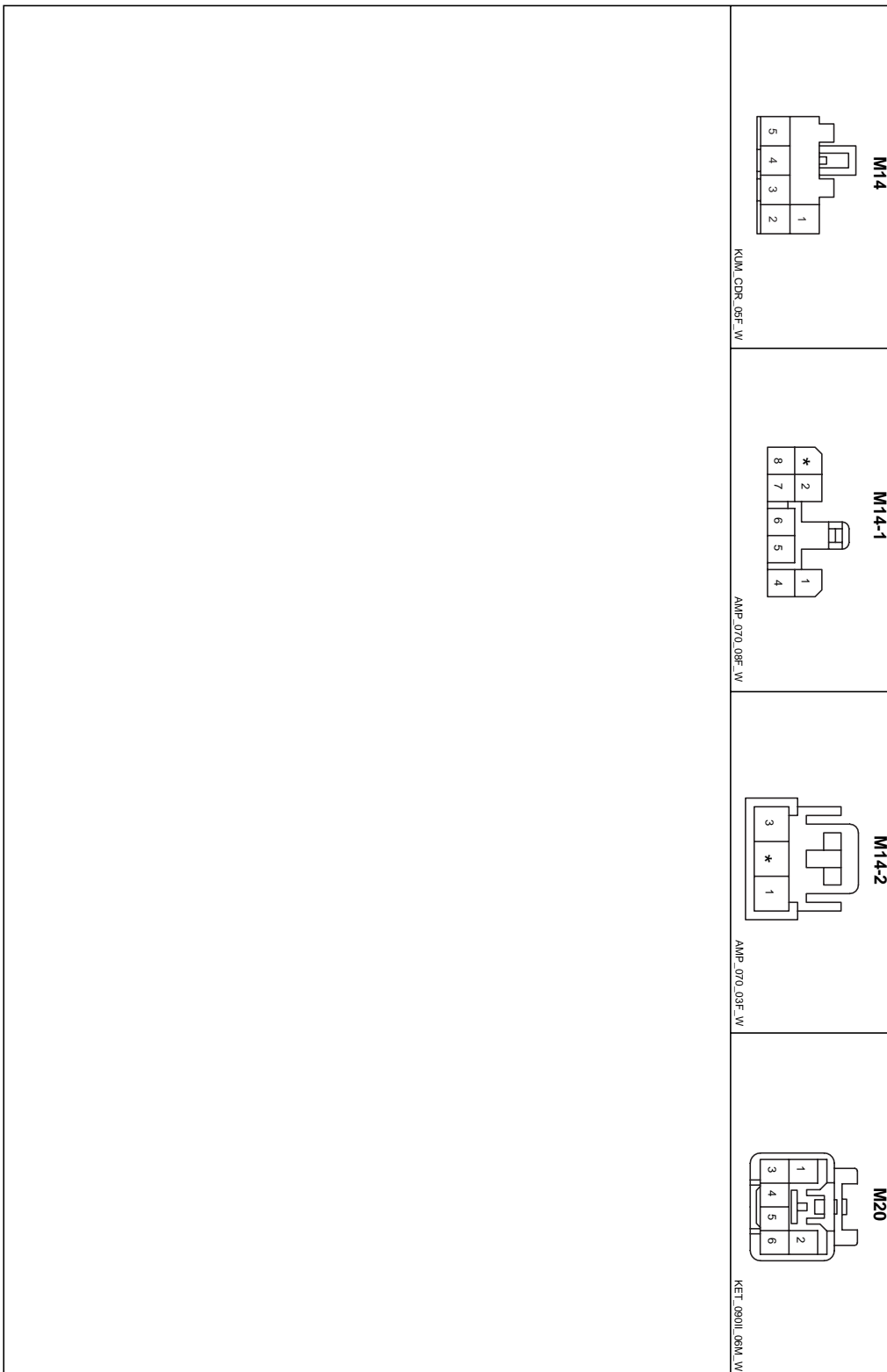

TEACHING PROCEDURES ED85CF8D

1. Key Teaching Procedure

Key teaching must be done after replacing a defective ECM (ICU) or when providing additional keys to the vehicle owner.

The procedure starts with an ECM (ICU) request for vehicle specific data (PIN code: 6digits) from the tester. The "virgin" ECM (ICU) stores the vehicle specific data and the key teaching can be started. The "learnt" ECM (ICU) compares the vehicle specific data from the tester with the stored data. If the data are correct, the teaching can proceed.

If incorrect vehicle specific data have been sent to the ECM (ICU) three times, the ECM (ICU) will reject the request of key teaching for one hour. This time cannot be reduced by disconnecting the battery or any other manipulation. After reconnecting the battery, the timer starts again for one hour.

The key teaching is done by ignition on with the key and additional tester commands. The ECM (ICU) stores the relevant data in the EEPROM and in the transponder. Then the ECM (ICU) runs the authentication required for confirmation of the teaching process. The successful programming is then confirmed by a message to the tester.

If the key is already known to the ECM (ICU) from a previous teaching, the authentication will be accepted and the EEPROM data are updated. There is no changed transponder content (this is impossible for a learnt transponder).

The attempt to repeatedly teach a key, which has been taught already during the same teaching cycle, is recognized by the ECM (ICU). This rejects the key and a message is sent to the tester.

The ECM (ICU) rejects invalid keys, which are presented for teaching. A message is sent to the tester. The key can be invalid due to faults in the transponder or other reasons, which result from unsuccessful programming of data. If the ECM (ICU) detects different authenticators of a transponder and an ECM (ICU), the key is considered to be invalid.

The maximum number of taught keys is 4

If an error occurs during the Immobilizer Service Menu, the ECM (ICU) status remains unchanged and a specific fault code is stored.

If the ECM (ICU) status and the key status do not match for teaching of keys, the tester procedure will

be stopped and a specific fault code will be stored at ECM (ICU).

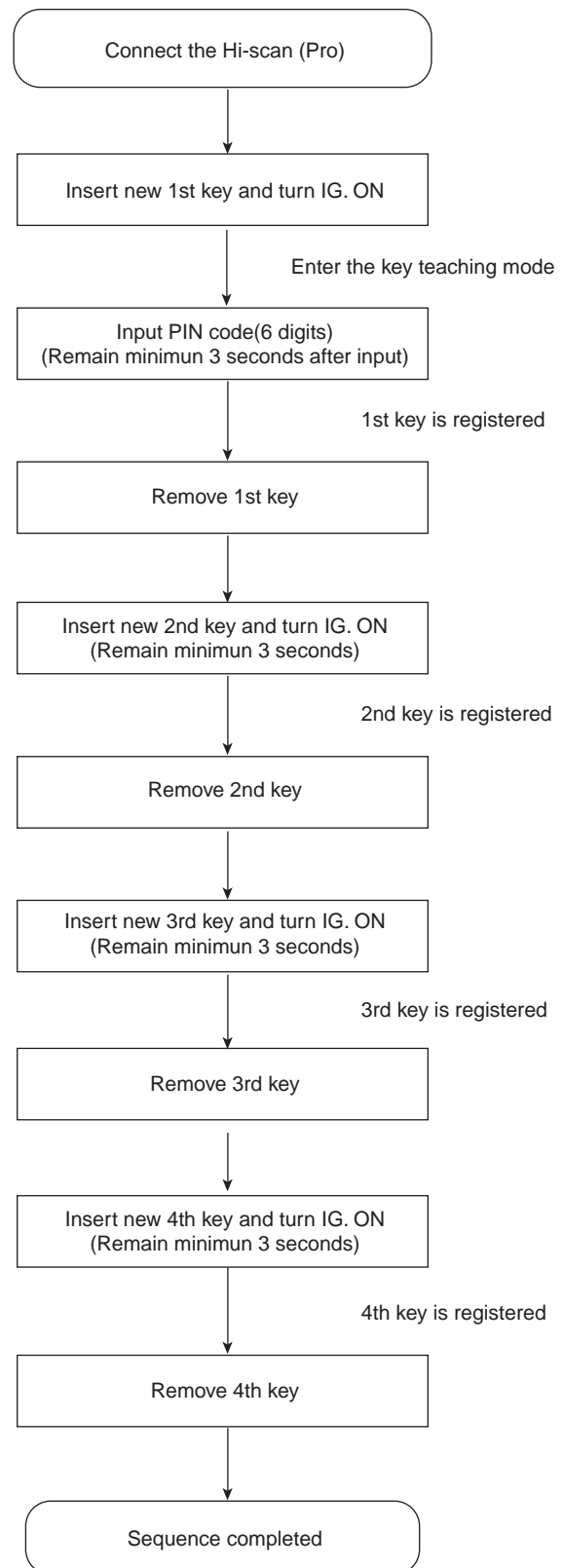

1) ECM learnt status.

1. KIA VEHICLE DIAGNOSIS ▼

MODEL : SPORTAGE

- 01. ENGINE 2.0L(GASOLINE)
- 02. ENGINE 2.7L(GASOLINE)
- 03. ENGINEL(DIESEL)
- 04. AUTOMATIC TRANSAXLE
- 05. ANTI-LOCK BRAKE SYSTEM
- 06. SRS-AIRBAG
- 07. 4WD CONTROL
- 08. IMMOBILIZER**

LTIF741A

1.3 TEACHING

MODEL : SPORTAGE  
SYSTEM : IMMOBILIZER  
STATUS : LEARNT

1st KEY TEACHING  
ARE YOU SURE ? [Y/N]

CODE : 234567

LTIF741D

1. KIA VEHICLE DIAGNOSIS

MODEL : SPORTAGE  
SYSTEM : IMMOBILIZER

- 01. CURRENT DATA
- 02. PASSWORD TEACHING/CHANGING
- 03. TEACHING**
- 04. NEUTRAL MODE
- 05. LIMP HOME MODE

LTIF741B

1.3 TEACHING

MODEL : SPORTAGE  
SYSTEM : IMMOBILIZER  
STATUS : LEARNT

1st KEY TEACHING  
COMPLETED

CODE : 234567

LTIF741E

1.3 TEACHING

MODEL : SPORTAGE  
SYSTEM : IMMOBILIZER  
STATUS : LEARNT

INPUT PIN OF SIX  
FIGURE AND PRESS [ENTER] KEY

CODE : 234567

LTIF741C

1.3 TEACHING

MODEL : SPORTAGE  
SYSTEM : IMMOBILIZER  
STATUS : LEARNT

2st KEY TEACHING  
ARE YOU SURE ? [Y/N]

CODE : 234567

LTIF741F

1.3 TEACHING
MODEL : SPORTAGE SYSTEM : IMMOBILIZER STATUS : LEARNT
2st KEY TEACHING COMPLETED
CODE : 234567

LTIF741G

1.3 TEACHING
MODEL : SPORTAGE SYSTEM : IMMOBILIZER STATUS : VIRGIN
1st KEY TEACHING COMPLETED
CODE : 234567

LTIF741J

- 2) ECM virgin status.  
After replacing new "ECM" scantool displays that ECM is virgin status in Key Teaching mode.  
"VIRGIN" status means that ECM has not matched any PIN code before.

1.3 TEACHING
MODEL : SPORTAGE SYSTEM : IMMOBILIZER STATUS : VIRGIN
INPUT PIN OF SIX FIGURE AND PRESS [ENTER] KEY
CODE : 234567

LTIF741H

1.3 TEACHING
MODEL : SPORTAGE SYSTEM : IMMOBILIZER STATUS : VIRGIN
2st KEY TEACHING ARE YOU SURE ? [Y/N]
CODE : 234567

LTIF741K

1.3 TEACHING
MODEL : SPORTAGE SYSTEM : IMMOBILIZER STATUS : VIRGIN
1st KEY TEACHING ARE YOU SURE ? [Y/N]
CODE : 234567

LTIF741I

1.3 TEACHING
MODEL : SPORTAGE SYSTEM : IMMOBILIZER STATUS : VIRGIN
2st KEY TEACHING COMPLETED
CODE : 234567

LTIF741L

2. User Password Teaching Procedure

The user password for limp home is taught at the service station. The owner of the vehicle can select a number with four digits.

User password teaching is only accepted by a "learnt" ECM (ICU). Before first teaching of user password to an ECM (ICU), the status of the password is "virgin" No limp home function is possible.

The teaching is started by ignition on, with a valid key and sending the user password by tester. After successful teaching, the status of the user password changes from "virgin" to "learnt".

The learnt user password can also be changed. This can be done if the user password status is "learnt" and the tester sends authorization of access, either the old user password or the vehicle specific data. After correct authorization, the ECM (ICU) requests the new user password. The status remains "learnt" and the new user password will be valid for the next limp home mode.

If incorrect user passwords or wrong vehicle specific data have been sent to the ECM (ICU) three times, the ECM (ICU) will reject the request to change the password for one hour. This time cannot be reduced by disconnecting the battery or any other actions. After reconnecting the battery, the timer starts again for one hour.

1) User password teaching

1. KIA VEHICLE DIAGNOSIS
MODEL : SPORTAGE SYSTEM : IMMOBILIZER
01. CURRENT DATA <b>02. PASSWORD TEACHING/CHANGING</b> 03. TEACHING 04. NEUTRAL MODE 05. LIMP HOME MODE

LTIF741M

1.2 PASSWORD TEACHING/CHANGING
MODEL : SPORTAGE SYSTEM : IMMOBILIZER STATUS : VIRGIN
INPUT NEW PASSWORD OF FOUR FIGURES AND PRESS [ENTER] KEY
NEW PASSWORD :

LTIF741N

1.2 PASSWORD TEACHING/CHANGING
MODEL : SPORTAGE SYSTEM : IMMOBILIZER STATUS : VIRGIN
INPUT NEW PASSWORD OF FOUR FIGURES AND PRESS [ENTER] KEY
NEW PASSWORD : 2345

LTIF741O

1.2 PASSWORD TEACHING/CHANGING
MODEL : SPORTAGE SYSTEM : IMMOBILIZER STATUS : VIRGIN
ARE YOU SURE ? [Y/N]
NEW PASSWORD : 2345

LTIF741P

1.2 PASSWORD TEACHING/CHANGING

MODEL : SPORTAGE  
SYSTEM : IMMOBILIZER  
STATUS : VIRGIN

COMPLETED  
PRESS [ESC] TO EXIT

NEW PASSWORD : 2345

LTIF741Q

1.2 PASSWORD TEACHING/CHANGING

MODEL : SPORTAGE  
SYSTEM : IMMOBILIZER  
STATUS : LEARNT

INPUT OLD PASSWORD OF FOUR  
FIGURES AND PRESS [ENTER] KEY

OLD PASSWORD : 2345

LTIF741S

In case of putting wrong password, retry from first step after 10 seconds.

2) User password changing

1. KIA VEHICLE DIAGNOSIS

MODEL : SPORTAGE  
SYSTEM : IMMOBILIZER

01. CURRENT DATA  
**02. PASSWORD TEACHING/CHANGING**  
03. TEACHING  
04. NEUTRAL MODE  
05. LIMP HOME MODE

LTIF741M

1.2 PASSWORD TEACHING/CHANGING

MODEL : SPORTAGE  
SYSTEM : IMMOBILIZER  
STATUS : LEARNT

INPUT NEW PASSWORD OF FOUR  
FIGURES AND PRESS [ENTER] KEY

NEW PASSWORD : 1234

LTIF741T

1.2 PASSWORD TEACHING/CHANGING

MODEL : SPORTAGE  
SYSTEM : IMMOBILIZER  
STATUS : LEARNT

INPUT OLD PASSWORD OF FOUR  
FIGURES AND PRESS [ENTER] KEY

OLD PASSWORD :

LTIF741R

1.2 PASSWORD TEACHING/CHANGING

MODEL : SPORTAGE  
SYSTEM : IMMOBILIZER  
STATUS : LEARNT

ARE YOU SURE ? [Y/N]

NEW PASSWORD : 1234

LTIF741U

1.2 PASSWORD TEACHING/CHANGING

MODEL : SPORTAGE  
SYSTEM : IMMOBILIZER  
STATUS : LEARNT

COMPLETED  
PRESS [ESC] TO EXIT

NEW PASSWORD : 1234

LTIF741V

1.5 LIMP HOME MODE

MODEL : SPORTAGE  
SYSTEM : IMMOBILIZER

INPUT PASSWORD OF FOUR  
FIGURES AND PRESS [ENTER] KEY

PASSWORD :

LTIF741X

**LIMP HOME FUNCTION**

EB5BBD0B

1. LIMP HOME BY TESTER

If the ECM (ICU) detects the fault of the SMARTRA or transponder, the ECM (ICU) will allow limp home function of the immobilizer. Limp home is only possible if the user password (4 digits) has been given to the ECM (ICU) before. This password can be selected by the vehicle owner and is programmed at the service station.

The user password can be sent to the ECM (ICU) via the special tester menu.

Only if the ECM (ICU) is in status "learnt" and the user password status is "learnt" and the user password is correct, the ECM (ICU) will be unlocked for a period of time (30 sec.). The engine can only be started during this time. After the time has elapsed, engine start is not possible.

If the wrong user password is sent, the ECM (ICU) will reject the request of limp home for one hour. Disconnecting the battery or any other action cannot reduce this time. After connecting the battery to the ECM (ICU), the timer starts again for one hour.

1.5 LIMP HOME MODE

MODEL : SPORTAGE  
SYSTEM : IMMOBILIZER

INPUT PASSWORD OF FOUR  
FIGURES AND PRESS [ENTER] KEY

NEW PASSWORD : 2345

LTIF741Y

1.5 LIMP HOME MODE

MODEL : SPORTAGE  
SYSTEM : IMMOBILIZER

COMPLETED  
PRESS [ESC] TO EXIT

LTIF741Z

1. KIA VEHICLE DIAGNOSIS

MODEL : SPORTAGE  
SYSTEM : IMMOBILIZER

01. CURRENT DATA  
02. PASSWORD TEACHING/CHANGING  
03. TEACHING  
04. NEUTRAL MODE  
05. LIMP HOME MODE

LTIF741W

**2. LIMP HOME BY IGNITION KEY**

The limp home can be activated also by the ignition key. The user password can be input to the ECM (ICU) by a special sequence of ignition on/off. Only if the ECM (ICU) is in status "learnt" and the user password status is "learnt" and the user password is correct, the ECM (ICU) will be unlocked for a period

of time (30 sec.). The engine can be started during this time. After the time has elapsed, engine start is not possible. After a new password has been input, the timer (30 sec.) will start again. After ignition off, the ECM (ICU) is locked if the timer has elapsed 8 seconds. For the next start, the input of the user password is requested again.

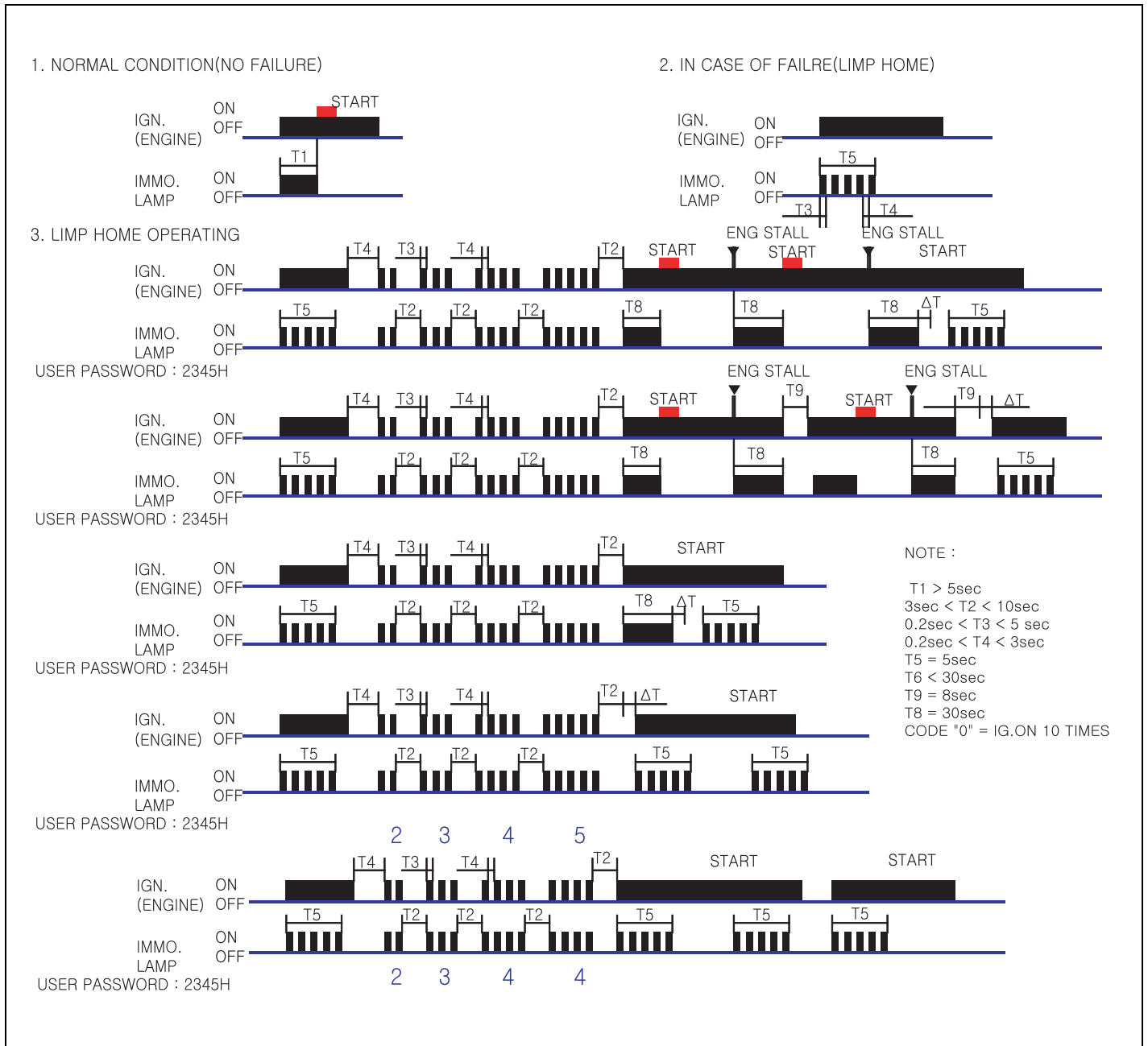

LTIF740N

**DIAGNOSIS OF IMMOBILIZER**

**FAULTS** E52E3C03

- Communication between the ECM and the SMARTRA/ICU.
- Function of the SMARTRA/ICU and the transponder.

- Data (stored in the ECM/ICU related to the immobilizer function.

The following table shows the assignment of immobilizer related faults to each type:

**[D 2.0 ENGINE]**

<b>Immobilizer Related Faults</b>	<b>Fault types</b>	<b>Diagnostic codes</b>
SMARTRA fault	<ol style="list-style-type: none"><li>1. Antenna coil error</li><li>2. Communication line error (Open/Short etc.)</li><li>3. Invalid message from SMARTRA to ECM.</li></ol>	P1690 (SMARTRA no response)
Immobilizer indicator lamp error	<ol style="list-style-type: none"><li>1. Immobilizer indicator lamp error (Cluster)</li></ol>	P1692 (Immobilizer lamp error)
Transponder fault	<ol style="list-style-type: none"><li>1. Corrupted data from transponder.</li><li>2. More than one transponder in the magnetic field (Antenna coil).</li><li>3. No transponder (Key without transponder) in the magnetic field (Antenna coil).</li><li>4. Transponder not in the password mode.</li><li>5. Transponder transport data has been changed.</li><li>6. Transponder programming error.</li></ol>	P1693 (Transponder no response error/ invalid response)
ECM internal permanent memory (EEPROM) fault	<ol style="list-style-type: none"><li>1. ECM internal permanent memory (EEPROM) fault.</li><li>2. Invalid write operation to permanent memory (EEPROM)</li></ol>	P1695 (ECM memory error)
Invalid key fault	<ol style="list-style-type: none"><li>1. Virgin transponder at EMS status "Learnt".</li><li>2. Learnt (Invalid) Transponder at EMS status "Learnt"(Authentication fail).</li></ol>	P1696 (Authentication fail) P1698 (Invalid transponder)
Tester (HI-SCAN) fault	<ol style="list-style-type: none"><li>1. Request from tester is invalid. (Protocol layer violation- Invalid request, check sum error etc.).</li></ol>	P1697 (Tester message error)

**IMMOBILIZER CONTROL SYSTEM**

**BE -187**

[ 2.0 ENGINE]

<b>Immobilizer Related Faults</b>	<b>Fault types</b>	<b>Diagnostic codes</b>
SMARTRA fault	1. Communication line error (Open/Short etc.) 2. Invalid message from SMARTRA to ECM.	P1690 (SMARTRA error)
Antenna coil fault	1. Antenna coil error.	P1691 (Antenna error)
Transponder fault	1. Corrupted data from transponder. 2. More than one transponder in the magnetic field (Antenna coil). 3. No transponder (Key without transponder) in the magnetic field (Antenna coil). 4. Transponder not in the password mode. 5. Transponder transport data has been changed. 6. Transponder programming error.	P1693 (Transponder error)
ECM fault	1. Request from ECM is invalid. (Protocol layer violation- Invalid request, check sum error etc.)	P1694 (ECU signal error)
ECM internal permanent memory (EEPROM) fault	1. ECM internal permanent memory (EEPROM) fault 2. Invalid write operation to permanent memory (EEPROM)	P1695 (ECM memory error)
Invalid key fault	1. Virgin transponder at ECM status "Learnt". 2. Learnt (Invalid) Transponder at ECM status "Learnt"(Authentication fail).	P1696 (Mismatch error)

[ 2.7 ENGINE]

<b>Immobilizer Related Faults</b>	<b>Fault types</b>	<b>Diagnostic codes</b>
ICU internal permanent memory (EEPROM) fault	1. ICU internal permanent memory (EEPROM) fault. 2. Invalid write operation to permanent memory (EEPROM).	P1677 (EMS VIN data error)
ICU fault	1. Communication line error (Open/Short etc.) 2. Invalid message from ICU to ECM.	P1678 (EMS no request)
ICU fault	1. Request from ICU is invalid. (Protocol layer violation- Invalid request, check sum error etc.)	P1679 (EMS data fail)
Antenna coil fault	1. Antenna coil error	P1691 (Antenna error)
Transponder fault	1. Corrupted data from transponder. 2. More than one transponder in the magnetic field (Antenna coil). 3. No transponder (Key without transponder) in the magnetic field (Antenna coil). 4. Transponder not in the password mode. 5. Transponder transport data has been changed. 6. Transponder programming error.	P1693 (Transponder error)
Invalid key fault	1. Virgin transponder at EMS status "Learnt". 2. Learnt (Invalid) Transponder at EMS status "Learnt"(Authentication fail).	P1698 (Transponder invalid)

**PROBLEMS AND REPLACEMENT**

**PARTS:** EAF314BE

Problem	Part set	Scan tool required?
All keys have been lost	Blank key (4)	YES
Antenna coil unit does not work	Antenna coil unit	NO
ECM/ICU does not work	ECM/ICU	YES
Ignition switch does not work	Ignition switch with Antenna coil unit	YES
Unidentified vehicle specific data occurs	Key, ECM/ICU	YES
SMARTRA unit does not work	SMARTRA unit	NO

**REPLACEMENT OF ECM/ICU AND SMARTRA**

In case of a defective ECM/ICU, the unit has to be replaced with a "virgin" or "neutral" ECM/ICU. All keys have to be taught to the new ECM/ICU. Keys, which are not taught to the ECM/ICU, are invalid for the new ECM/ICU (Refer to key teaching procedure). The vehicle specific data have to be left unchanged due to the unique programming of transponder.

In case of a defective SMARTRA, there is no special procedure required. A new SMARTRA device simply replaces the old one. There are no transponder-related data stored in this device.

1. Things to remember before a replacement (ECM/ICU)

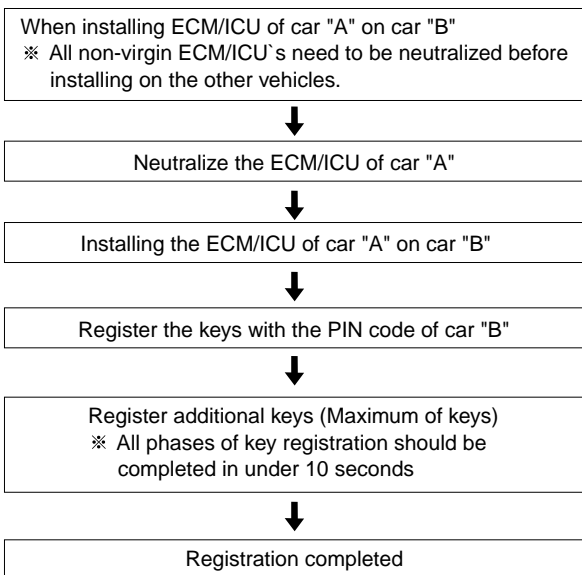

LTIF746A

2. Things to remember before a replacement (Keys & Additional registration)

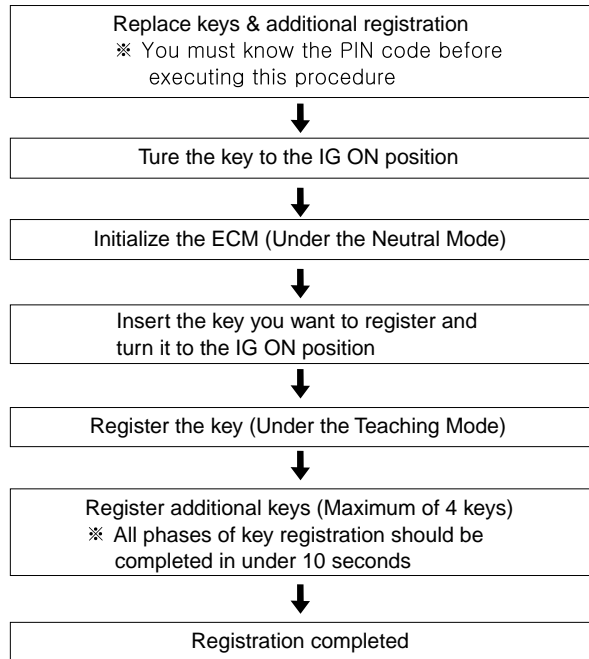

LTIF746B

**NOTE**

- When there is only one key registered and you wish to register another key, you need to re-register the key which was already registered.
- When the key #1 is registered and master key #2 is not registered, Put the key #1 in the IG/ON or the start position and remove it. The engine can be started with the unregistered key #2. (Note that key #2 must be used within 10 seconds of removing key #1)
- When the key #1 is registered and key #2 is not registered, put the unregistered master key #2 in the IG/ON or the start position. The engine cannot be started even with the registered key #1.
- When you inspect the immobilizer system, refer to the above paragraphs 1, 2 and 3. Always remember the 10 seconds zone.
- If the pin code & password are entered incorrectly on three consecutive inputs, the system will be locked for one hour.
- Be cautious not to overlap the transponder areas.
- Problems can occur at key registration or vehicle starting if the transponders should overlap.

**NEUTRALISING OF ECM/ICU**

The ECM/ICU can be set to the "neutral" status by a tester.

A valid ignition key is inserted and after ignition on is recorded, the ECM/ICU requests the vehicle specific data from the tester. The communication messages are described at "Neutral Mode" After successfully receiving the data, the ECM/ICU is neutralized.

The ECM/ICU remains locked. Neither the limp home mode nor the "twice ignition on" function, is accepted by the ECM/ICU.

The teaching of keys follows the procedure described for the virgin ECM/ICU. The vehicle specific data have to be unchanged due to the unique programming of the transponder. If data should be changed, new keys with a virgin transponder are requested.

**[D2.0, 2.0 engine]**

This function is for neutralizing the ECM and Key. Ex) when lost key, Neutralize the ECM then teach keys. (Refer to the Things to do when Key & PIN Code the ECM can be set to the "neutral" status by a scanner. A valid ignition key is inserted and after ignition on is recorded, the ECM requests the vehicle specific data from the scanner. The communication messages are described at " Neutral Mode". After successfully receiving the data, the ECM is neutralized.

The ECM remains locked. Neither the limp home mode nor the "twice ignition on" function is accepted by ECM.

The teaching of keys follows the procedure described for virgin ECM. The vehicle specific data have to be unchanged due to the unique programming of transponder. If data should be changed, new keys with virgin transponder are requested.

**[ 2.7 engine]**

This function is for neutralizing the ICU and ECU.

When replacing the ICU and ECM, The ICU and ECM need neutralization by scanner.

When neutralization immobilizer system, EEPROM data (VIN code, Password, Pin code, Key data) in the immobilizer are erased.

After doing neutralization of ICU by scanner, it is necessary to turn the key "OFF ON" Because ECM is neutralized by ICU.

 **NOTE**

- Neutralizing setting condition
  - In case of ECM status "Learnt" regardless of user password "Virgin or Learnt".
  - Input correct PIN code by scanner.
  - Neutralizing meaning .
    - : PIN code (6) & user password (4) deletion.
    - : Locking of ECM (except key teaching permission)

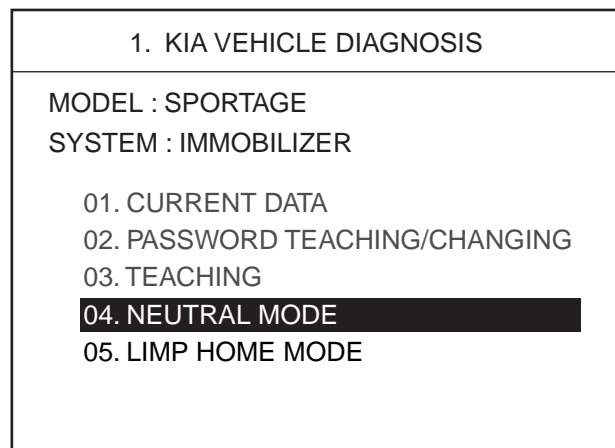

LTIF745A

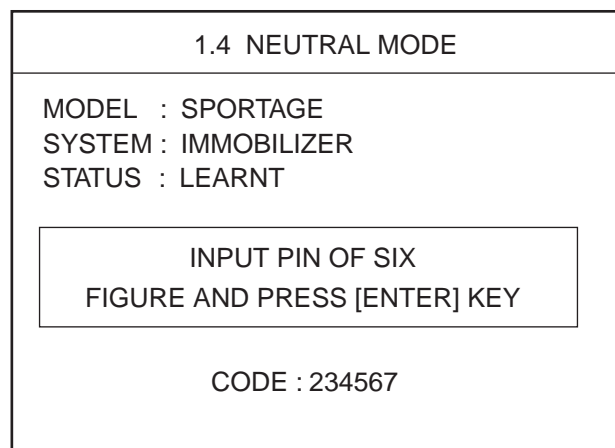

LTIF745E

1.4 NEUTRAL MODE
MODEL : SPORTAGE SYSTEM : IMMOBILIZER STATUS : NEUTRAL
COMPLETED PRESS [ESC] TO EXIT

LTIF745B

1. KIA VEHICLE DIAGNOSIS
MODEL : SPORTAGE SYSTEM : IMMOBILIZER
01. CURRENT DATA 02. PASSWORD TEACHING/CHANGING 03. TEACHING 04. NEUTRAL MODE 05. LIMP HOME MODE

LTIF745C

1.1 CURRENT DATE
01. NO. OF LEARNT KEY 0
02. ECU STATUS NEUTRAL
03. KEY STATUS NOT CHECK

FIX SCRN FULL PART GRPH HELP

LTIF745D

# IGNITION SYSTEM

## IGNITION SWITCH

### REPLACEMENT E5B27FB5

1. Disconnect the negative (-) battery terminal.
2. Disconnect the hood release cable from the hood release handle.
3. Remove the lower crash pad panel (A).

#### Fastener Locations

▶ : Screw, 3

▷ : Clip, 5

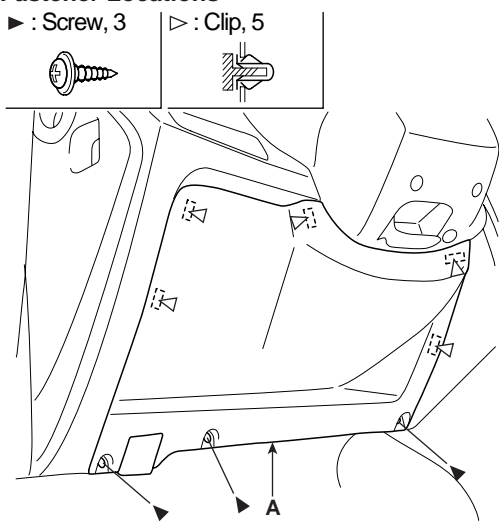

LSIE022D

4. Remove the ignition switch (A) after loosening the screw and disconnecting the 6P connector.

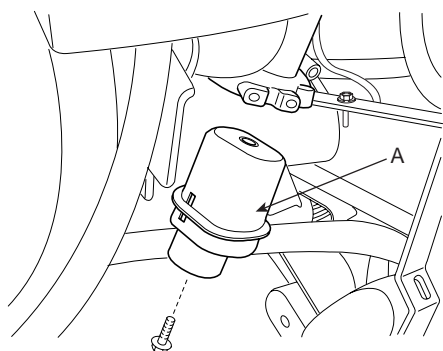

ATIE781A

5. Remove the steering column shaft (Refer to the ST group).

6. Remove the key warning switch (A) and key illumination lamp (B) after loosening the screws and disconnecting the 6P connector.

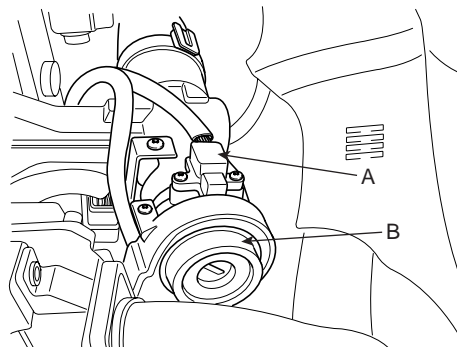

ATIE781B

7. If it is necessary to remove the key lock cylinder (A), remove the key lock cylinder (A) after pushing lock pin (B) with key ACC.

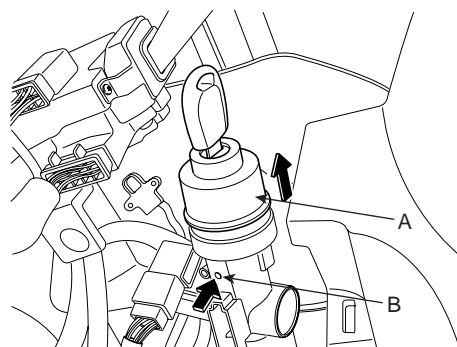

ATIE781C

8. Installation is the reverse of removal procedure.

**INSPECTION** EF0ABC07

1. Disconnect the ignition switch connector and key warning switch connector from under the steering column.
2. Check for continuity between the terminals.
3. If continuity is not specified, replace the switch.

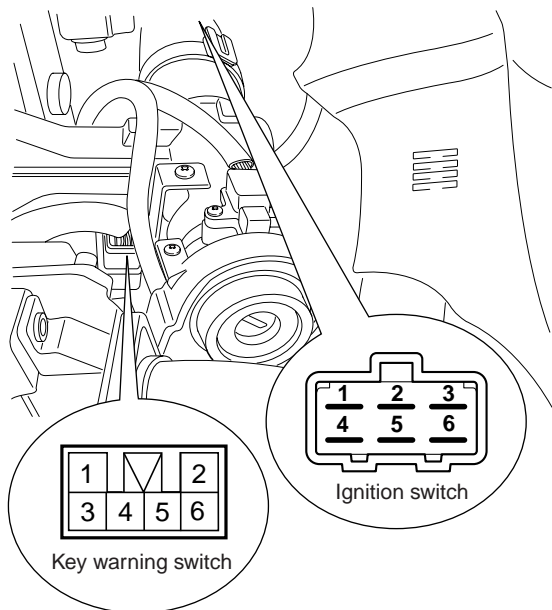

LTIF781D

POSITION	KEY	IGNITION SWITCH						STEERING		KEY WARNING SWITCH		KEY HOLE ILLUMINATION	
		2	4	6	5	3	1	TRAVEL	TRAVEL	5	6	3	4
LOCK	REMOVAL							LOCK					
	INSERT							LOCK	UNLOCK				
ACC		○—○					UNLOCK						
ON		○—○—○			○—○								
START	○—○—○			○—○—○									

LTIF781E

**DTC P1677 EMS VIN DATA ERROR (EMS HAS DIFFERENT VIN)**

**GENERAL DESCRIPTION** E4DF5620

Immobilizer Control Unit (ICU) supplies power to the coil antenna, receives and analyses signal from the transponder, transmits signal to engine ECM and stores VIN(Not the number on the bulkhead of vehicle but Vehicle Identification Number for Immobilizer ) data which composes of ID code and password.

**DTC DESCRIPTION** EB9CCAAA

ICU stores VIN which composes of ID code and password. This DTC is defined that VIN of EMS is inconsistent data of ICU.

**DTC DETECTING CONDITION** EFEA2C16

Item	Detecting condition	Possible cause
Enable Condition	• IG ON	• Faulty EMS
Detecting factors	• EMS VIN DATA error	
Detecting Criteria	• Inconsistent data between EMS and ICU	

**SIGNAL WAVEFORM AND DATA** EB2A2EF7

Current Data

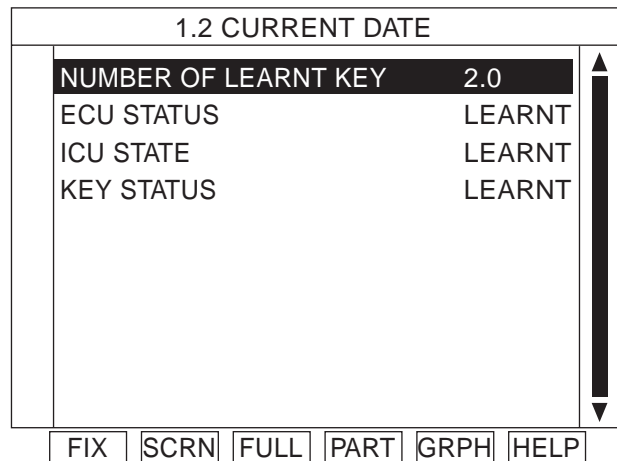

Fig 1

LTIF744A

EMS Status	Engine start with valid key	Engine start by limp home	Teaching of key	Teaching or changing of user password
Not yet checked	No	No	No	No
Virgin	No	No	Yes	No
Learnt	Yes	Yes, with learnt user password	Yes	Yes
Neutral	No	No	Yes	No
Locked by timer	No	No	No	No

Fig 2

LTIF742B

Current Data from Immobilizer will show the numbers of Key learnt, ECM status, ICU status, and Key status as Fig 1. Immobilizer function table depending on ECM status as Fig 2.

Thanks to this current data, the symptom of unable starting is probably assumed what problem it is.

1. ECU : VIN - It is Vehicle ID number which consists of ID code and password, not the vehicle body number,
  - 1) Virgin (This is status that ECM does not memorize VIN)
  - 2) Neutral (This is a status that VIN is erased on the ECM by special command from scantool)
  - 3) Learnt (This is a status that VIN is learnt on the ECM by special command from scantool)
  - 4) Not yet checked (The status is stored in permanent memory (EEPROM or Flash etc.). In case of not plausible data from this circuit the EMS cannot check the status.
2. ICU : VIN - It is Vehicle ID number which consists of ID code and password, not the vehicle body number,
  - 1) Virgin (This is status that ICU does not memorize VIN)
  - 2) Neutral (This is a status that VIN is erased on the ICU by special command from scantool)
  - 3) Learnt (This is a status that VIN is learnt on the ICU by special command from scantool)
  - 4) Not yet checked (The status is stored in permanent memory (EEPROM or Flash etc.). In case of not plausible data from this circuit the ICU cannot check the status.
  - 5) Locked by timer (After a certain number of incorrect user Password(4) or PIN Code(6) the ECM is locked for one hour and no inputs are accepted during this time)
3. KEY :
  - 1) Virgin (It means the key in the key cylinder has not matched with ICU yet)
  - 2) Learnt (It means the key in the key cylinder has matched with ICU)
  - 3) Invalid (mismatched)
    - Key with NO Transponder
    - More than 1(One) Transponder in the magnetic field
    - No Transponder in the magnetic field
    - TP data blocked
    - TP data does not exist
    - TP data changed
    - TP Teaching error
    - Multiple TP data input

- 4) Not yet checked [The status is stored in permanent memory (EEPROM or Flash etc)].  
In case of not plausible data from this circuit the ICU cannot check the status.

**MONITOR SCANTOOL DATA** E3B9BBED

- 1. Ignition "ON" and Engine "OFF".
- 2. After connecting Scantool, Monitor the DTCs and CURRENT DATA to check key status.

1.2 CURRENT DATE	
NUMBER OF LEARNT KEY	2.0
ECU STATUS	LEARNT
ICU STATE	LEARNT
KEY STATUS	LEARNT

FIX    SCRN    FULL    PART    GRPH    HELP

Fig 1

LTIF744A

- 3. Are both Key and ECU status learnt?

**YES**

Fault is intermittent caused by poor contact in the ICU and/or the engine ECU connector or was repaired and ICU memory was not cleared. Thoroughly check connectors for looseness, poor connection, bending, corrosion, contamination, deterioration, or damage.

Repair or replace as necessary and then go to "Verification of Vehicle Repair" procedure.

**NO**

If ECU status is not yet checked" is displayed, check engine ECU and then go to "Verification of Vehicle Repair" procedure.

**NOTE**

Be sure that P1677 can be displayed, when engine ECU has a different VIN DATA(Engine ECU is replaced by another vehicle's ECU) with ICU.

**VERIFICATION OF VEHICLE REPAIR** E5AEBD7C

After a repair, it is essential to verify that the fault has been corrected.

1. Connect scan tool and monitor "CURRENT DATA".
2. Select "Diagnostic Trouble Codes(DTCs)" mode and Clear the DTCs.
3. Are any DTCs present?

**YES**

Go to the applicable troubleshooting procedure.

**NO**

System is performing to specification at this time.

**DTC P1678 EMS NO REQUEST ( EMS DATA LINE OPEN, NO IMMO.)**

**GENERAL DESCRIPTION** EAB6CCD3

In the Ignition ON position, the engine ECM receives information from the ICM and permits injection to take place If the CODE memorized in ECM is conceded with ICM.

When the ID code from the transponder is verified by the ICM then the registering sequence is complete and a answer signal is sent to the ECM.

The ICM sends a START or NO START signal to the ECM.

**DTC DESCRIPTION** EAB5AC14

This DTC is defined as that there is no request code from EMS for 5 sec after ignition ON.

**DTC DETECTING CONDITION** E1FEBDA6

Item	Detecting condition	Possible cause
Enable Condition	• IG ON	• Open in harness between EMS and ICU • Faulty EMS
Detecting factors	• EMS no request	
Detecting Criteria	• No request from EMS for 5 sec	

**MONITOR SCANTOOL DATA** EFA24279

1. Ignition "ON" & Engine "OFF".
2. After connecting Scantool, Monitor the DTCs and CURRENT DATA to check key status.

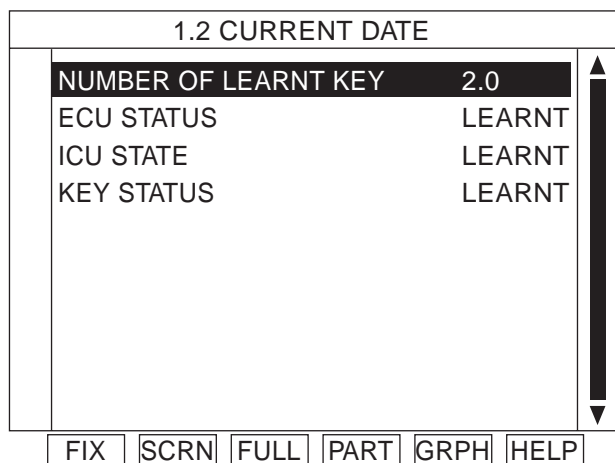

Fig 1

3. Are both Key and ECU status learnt?

**YES**

Go to "W/Harness Inspection" procedure.

**NO**

If ECU status is not yet checked" is displayed, check engine ECU and then go to "Verification of Vehicle Repair" procedure.



**NOTE**

*Be sure that P1678 can be displayed, when engine ECU is replaced by "Non-immobilizer" engine ECU.*

**TERMINAL AND CONNECTOR INSPECTION** E05C7E6F

1. Many malfunctions in the electrical system are caused by poor harness(es) and terminals. Faults can also be caused by interference from other electrical systems and mechanical or chemical damage.
2. Thoroughly check connectors for looseness, poor connection, bending, corrosion, contamination, deterioration, or damage.
3. Has a problem been found?

**YES**

Repair as necessary and then go to "Verification of Vehicle Repair" procedure.

**NO**

Go to "Signal Circuit Inspection" procedure.

**SIGNAL CIRCUIT INSPECTION** EC9F42BC

1. Ignition "OFF".
2. Disconnect ICU and engine ECU connector.

3. Measure resistance between terminal "6" of the ICU harness and "3" of the engine ECU harness.

Specification : Approx. 0

**NOTE**

The ICU communicate with the engine ECU by dedicated communication line.

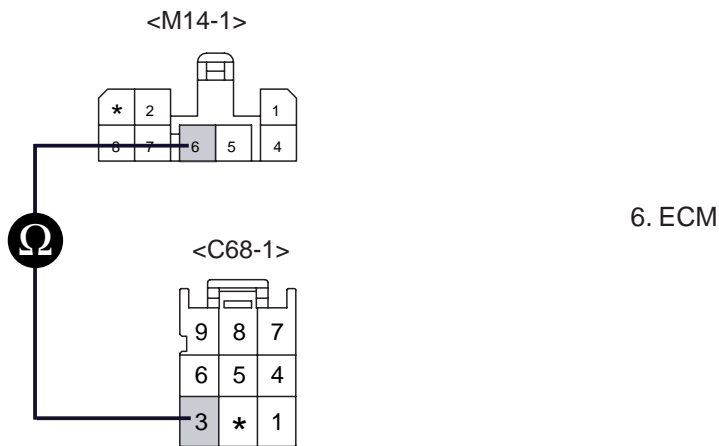

LTIF744B

4. Is measured resistances within specification?

**YES**

Go to "Verification of Vehicle Repair " procedure.

**NO**

Check for open or short in signal harness. Repair as necessary and then go to "Verification of Vehicle Repair" procedure.

**VERIFICATION OF VEHICLE REPAIR** E5628FAC

After a repair, it is essential to verify that the fault has been corrected.

1. Connect scan tool and monitor "CURRENT DATA".
2. Select "Diagnostic Trouble Codes(DTCs)" mode and Clear the DTCs.
3. Are any DTCs present?

**YES**

Go to the applicable troubleshooting procedure.

**NO**

System is performing to specification at this time.

**DTC P1679 EMS DATA FAIL (DATA FRAME, CS, MESSAGE ERROR)**

**GENERAL DESCRIPTION** E2EDBFCA

When the ID code from the transponder is verified by the ICU then the registering sequence is complete and a answer signal is sent to the EMS.  
The ICU sends a START or NO START signal to the EMS.

**DTC DESCRIPTION** ED1DF2C1

This DTC is defined as Invalid request from EMS or corrupted data.

**DTC DETECTING CONDITION** E6E3E1D7

Item	Detecting condition	Possible cause
Enable Condition	<ul style="list-style-type: none"><li>• IG ON</li></ul>	<ul style="list-style-type: none"><li>• Faulty EMS</li><li>• Faulty ICU</li></ul>
Detecting factors	<ul style="list-style-type: none"><li>• EMS Data fail</li></ul>	
Detecting Criteria	<ul style="list-style-type: none"><li>• Data frame error</li><li>• Check sum error</li><li>• Message error</li></ul>	

**MONITOR SCANTOOL DATA** EA1B1A65

1. Ignition "ON" and Engine "OFF".
2. Connect Scan tool and clear the DTCs.

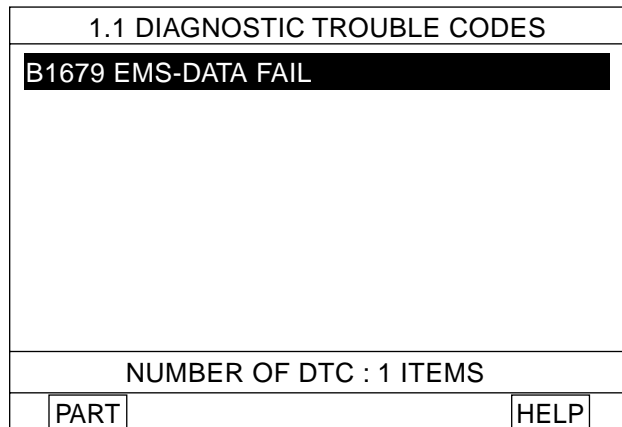

LTIF744C

3. Is DTC P1679 displayed again?

**YES**

Go to "Component Inspection" procedure.

**NO**

Fault is intermittent caused by poor contact in the ICU and/or the antenna coil connector or was repaired and ICU memory was not cleared. Thoroughly check connectors for looseness, poor connection, bending, corrosion, contamination, deterioration, or damage.  
Repair or replace as necessary and then go to "Verification of Vehicle Repair" procedure.

**COMPONENT INSPECTION**

E8B7BD59

**CHECK ECU**

1. Ignition "ON" and Engine "OFF".
2. Neutralize ICU and engine ECU with scanner.

 **NOTE**

1. *Be sure that PIN code is prepared before performing neutralization and key teaching.*
2. *After doing neutralization of ICU by scanner, It is necessary to turn the key "OFF ON". Because ECM is neutralized by ICU.*
3. Substitute with a known-good neutral ECU, and perform key teaching.
4. Monitor CURRENT DATA and DTCs.
5. Is DTC P1679 displayed again?

**YES**

Go to "Check ICU" procedure as below.

**NO**

Replace the engine ECU and Perform key, password teaching.

 **NOTE**

*Before replace the engine ECU, perform neutralization of the ICU.*

Check for proper operation and the go to "Verification of Vehicle Repair" procedure.

**CHECK ICU**

1. Ignition "ON" and Engine "OFF".
2. Neutralize ICU and engine ECU with scanner.

 **NOTE**

1. *Be sure that PIN code is prepared before performing neutralization and key teaching.*
2. *After doing neutralization of ICU by scanner, It is necessary to turn the key "OFF ON". Because ECM is neutralized by ICU.*
3. Substitute with a known-good neutral ICU, and perform key teaching.
4. Monitor CURRENT DATA and DTCs.

5. Is DTC P1679 displayed again?

**YES**

Thoroughly check connectors for looseness, poor connection, bending, corrosion, contamination, deterioration, or damage.

Repair or replace as necessary and then go to "Verification of Vehicle Repair" procedure.

**NO**

Replace the ICU and Perform key, password teaching.



**NOTE**

*Before replace the ICU, perform neutralization of the engine ECU.*

Check for proper operation and the go to "Verification of Vehicle Repair" procedure.

**VERIFICATION OF VEHICLE REPAIR** E0FF262F

After a repair, it is essential to verify that the fault has been corrected.

1. Connect scan tool and monitor "CURRENT DATA".
2. Select "Diagnostic Trouble Codes(DTCs)" mode and Clear the DTCs.
3. Are any DTCs present?

**YES**

Go to the applicable troubleshooting procedure.

**NO**

System is performing to specification at this time.

**DTC P1690 SMARTRA NO RESPONSE**

**GENERAL DESCRIPTION** E54D2A5B

The SMARTRA carries out communication with the built-in transponder of the ignition key. This wireless communication runs on RF (Radio frequency of 125 kHz). The SMARTRA is mounted at the ignition lock close to the antenna coil for RF transmission and receiving.

The RF signal from the transponder received by the antenna coil is converted into messages for serial communication by the SMARTRA device. And the received messages from the ECM are converted into an RF signal, which is transmitted, to the transponder by the antenna. The SMARTRA does not carry out the validity check of transponder or the calculation of encryption algorithm. This device is only an advanced interface, which converts the RF data flow of the transponder into serial communication to ECM and vice versa.

**DTC DESCRIPTION** EDA4D797

**[D2.0 ENGINE]**

This DTC is defined that ECM has No answer from SMARTRA because of SMARTRA error.

**[ 2.0 ENGINE]**

This DTC is defined that ECM has No answer or Invalid message from SMARTRA to ECM because of SMARTRA faulty.

**DTC DETECTING CONDITION** E3E5CB2B

**[D2.0 ENGINE]**

Item		Detecting Condition	Possible cause
Enable Condition		<ul style="list-style-type: none"><li>IG ON</li></ul>	<ul style="list-style-type: none"><li>Open or short in Antenna circuit</li><li>Faulty SMARTRA</li><li>Faulty ECM</li></ul>
Detecting Factors		<ul style="list-style-type: none"><li>Antenna Coil error (Case 1)</li><li>Invalid request from ECM or Corrupted data (Case 2)</li><li>Transponder Program error (Case 3)</li></ul>	
Case 1	Detecting Window	<ul style="list-style-type: none"><li>Before transponder communications</li></ul>	
	Detecting Criteria	<ul style="list-style-type: none"><li>Antenna open/short circuit</li></ul>	
Case 2	Detecting Window	<ul style="list-style-type: none"><li>ECM request message</li></ul>	
	Detecting Criteria	<ul style="list-style-type: none"><li>Protocol layer violation-Invalid request or invalid check sum</li></ul>	
Case 3	Detecting Window	<ul style="list-style-type: none"><li>During Transponder Write EEPROM page request While Transponder is in authorized state.</li></ul>	
	Detecting Criteria	<ul style="list-style-type: none"><li>Corrupted data from Transponder(TP), or more than on TP in the field, or no TP in the field.</li></ul>	

[ 2.0 ENGINE]

Item	Detecting Condition	Possible cause
Enable Condition	<ul style="list-style-type: none"> <li>IG ON</li> </ul>	<ul style="list-style-type: none"> <li>Open or Short in SMARTRA Circuit</li> <li>Faulty SMARTRA</li> <li>Faulty ECM</li> </ul>
Detecting Criteria	<ul style="list-style-type: none"> <li>No answer from SMARTRA</li> <li>Invalid message from SMARTRA to ECM</li> </ul>	

**SIGNAL WAVEFORM** E6DC4139

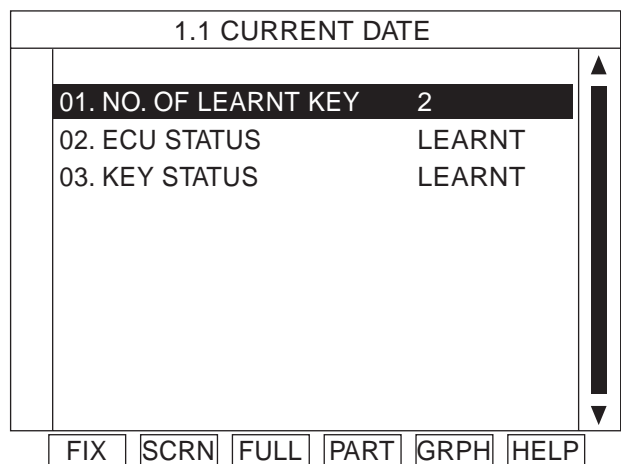

Fig 1

LTIF742A

EMS Status	Engine start with valid key	Engine start by limp home	Teaching of key	Teaching or changing of user password
Not yet checked	No	No	No	No
Virgin	No	No	Yes	No
Learnt	Yes	Yes, with learnt user password	Yes	Yes
Neutral	No	No	Yes	No
Locked by timer	No	No	No	No

Fig 2

LTIF742B

1. ECM :

- 1) Virgin(This is status at the end of ECM production line before delivery to customer)
- 2) Neutral (This is a status that is erased all data regarding immobilizer by special command from scanner)
- 3) Not Check (The status is stored in permanent memory (EEPROM or Flash etc.) In case of not plausible data from this circuit the ECM cannot check the status.
- 4) Locked by timer (After a certain number of incorrect user Password(4) or PIN Code(6) the ECM is locked for one hour and no inputs are accepted during this time)

2. KEY :

- 1) Virgin (It means the key in the key cylinder has not matched with ECM yet)
- 2) Invalid (mismatched)
  - Key with NO Transponder
  - More than 1(One) Transponder in the magnetic field
  - No Transponder in the magnetic field
  - TP data blocked
  - TP data does not exist
  - TP data changed
  - TP Teaching error
  - Multiple TP data input

Current Data from Immobilizer will show the numbers of Key learnt, ECM status, and Key status as Fig 1. Thanks to this current data, the symptom of unable starting is probably assumed what problem it is. Fig 2. shows possibility of Engine start, Teaching or changing of user password according to ECM status.

**MONITOR SCANTOOL DATA** E41011D6

- 1. Ignition "ON" & Engine "OFF".
- 2. Connect Scan tool and clear the DTCs.
- 3. If the DTCs are retrieved again, monitor "CURRENT DATA" to check No. of Learnt key, ECM and KEY status.

1.1 CURRENT DATE	
01. NO. OF LEARNT KEY	0
02. ECU STATUS	VIRGIN
03. KEY STATUS	VIRGIN

FIX    SCRN    FULL    PART    GRPH    HELP

Fig 1

LTIF742C

1.1 CURRENT DATE	
01. NO. OF LEARNT KEY	1
02. ECU STATUS	NOT CHECK
03. KEY STATUS	INVALID

FIX   SCRN   FULL   PART   GRPH   HELP

Fig 2

LTIF742D

1.1 CURRENT DATE	
01. NO. OF LEARNT KEY	1
02. ECU STATUS	LEARNT
03. KEY STATUS	INVALID

FIX   SCRN   FULL   PART   GRPH   HELP

Fig 3

LTIF742E

1.1 CURRENT DATE	
01. NO. OF LEARNT KEY	2
02. ECU STATUS	LEARNT
03. KEY STATUS	LEARNT

FIX   SCRN   FULL   PART   GRPH   HELP

Fig 4

LTIF742F

- Fig 1 : ECM has not matched with any Key yet.
- Fig 2 : ECM Internal Failure.
- Fig 3 : IG On with unmatched key.
- Fig 4 : 2(two) Keys have been matched with ECM.

4. Are both Key and ECM status learnt?

**YES**

Fault is intermittent caused by poor contact in the SMARTRA's and/or ECM's connector or was repaired and ECM memory was not cleared. Thoroughly check connectors for looseness, poor connection, bending, corrosion, contamination, deterioration, or damage.

Repair or replace as necessary and then go to "Verification of Vehicle Repair" procedure.

**NO**

Go to "W/Harness Inspection" procedure.

**TERMINAL AND CONNECTOR INSPECTION** EA249733

1. Many malfunctions in the electrical system are caused by poor harness and terminals.  
Faults can also be caused by interference from other electrical systems, and mechanical or chemical damage.
2. Thoroughly check connectors for looseness, poor connection, bending, corrosion, contamination, deterioration, or damage.
3. Has a problem been found?

**YES**

Repair as necessary and go to "Verification of Vehicle Repair" procedure.

**NO**

Go to " Power Circuit Inspection " procedure.

**POWER SUPPLY CIRCUIT INSPECTION** EAD1EB98

1. Ignition "OFF".
2. Disconnect SMARTRA connector.
3. Ignition "ON" & Engine "OFF".
4. Measure voltage between terminal 4 of the SMARTRA harness connector and chassis ground.

---

Specification : B+

---

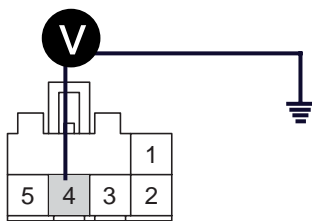

- 3. Ground
- 4. Power

LTIF742G

5. Is the measured voltage within specifications?

**YES**

Go to "Signal Circuit Inspection" procedure.

**NO**

Check open or short in power harness.

Check that 10A SENSOR fuse located between Control relay and Smartra is open or blown off.

Repair as necessary and go to "Verification of Vehicle repair" procedure.

**SIGNAL CIRCUIT INSPECTION** EAB8DF86

**[D2.0 ENGINE]**

1. Check for short in harness.
  - 1) Ignition "OFF".
  - 2) Disconnect SMARTRA connector.
  - 3) Ignition "ON" & Engine "OFF".
  - 4) Measure voltage between terminal 5 of the SMARTRA harness connector and chassis ground.

---

Specification : Approx. 6.0V

---

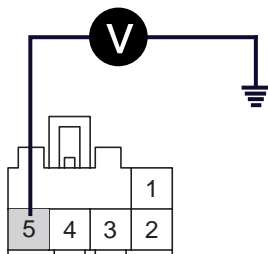

5. Signal

LTIF742H

- 5) Is the measured voltage within specifications?

**YES**

Go to "Check for open in harness" as below.

**NO**

Check short in signal harness.

Repair as necessary and go to "Verification of Vehicle repair" procedure.

2. Check for open in harness
  - 1) Ignition "OFF".
  - 2) Disconnect SMARTRA connector.
  - 3) Measure resistance between terminal 5 of the SMARTRA harness connector and terminal 11 of ECM harness connector.

Specification : Approx. below 1

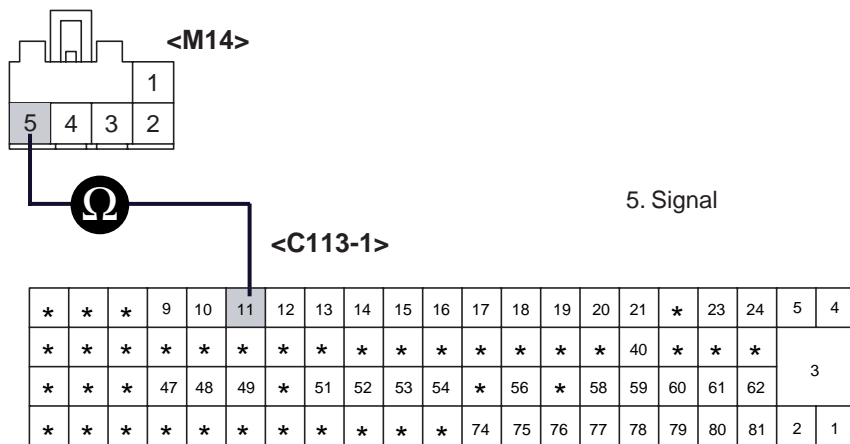

LTIF742I

- 4) Is the measured resistance within specifications?

**YES**

Go to "Ground Circuit Inspection" procedure.

**NO**

Check for open in signal harness.

Repair as necessary and go to "Verification of Vehicle repair" procedure.

[ 2.0 ENGINE]

1. Check for short in harness.
  - 1) Ignition "OFF".
  - 2) Disconnect SMARTRA connector.
  - 3) Ignition "ON" & Engine "OFF".
  - 4) Measure voltage between terminal 5 of the SMARTRA harness connector and chassis ground.

---

Specification : Approx. 6.0V

---

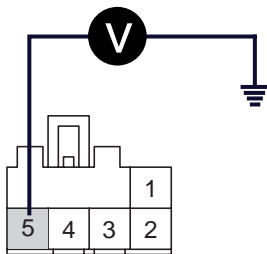

5. Signal

LTIF742H

- 5) Is the measured voltage within specifications?

**YES**

Go to "Check for open in harness" as below.

**NO**

Check short in signal harness.

Repair as necessary and go to "Verification of Vehicle repair" procedure.

2. Check for open in harness

- 1) Ignition "OFF".
- 2) Disconnect SMARTRA connector.
- 3) Measure resistance between terminal 5 of the SMARTRA harness connector and terminal 47 of ECM harness connector.

Specification : Approx. below 1

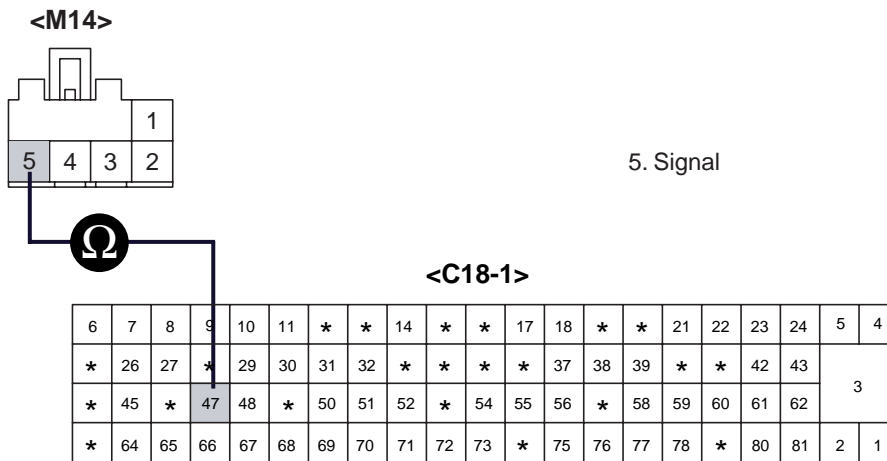

LTIF743B

4) Is the measured resistance within specifications?

**YES**

Go to "Ground Circuit Inspection" procedure.

**NO**

Check for open in signal harness.

Repair as necessary and go to "Verification of Vehicle repair" procedure.

**GROUND CIRCUIT INSPECTION** EC1FA19E

**[D2.0 ENGINE]**

1. Check for open in harness between SMARTRA and Chassis ground.
  - 1) Ignition "OFF".
  - 2) Disconnect SMARTRA connector.
  - 3) Measure resistance between terminal 3 of the SMARTRA harness connector and Chassis ground.

---

Specification : Approx. below 1

---

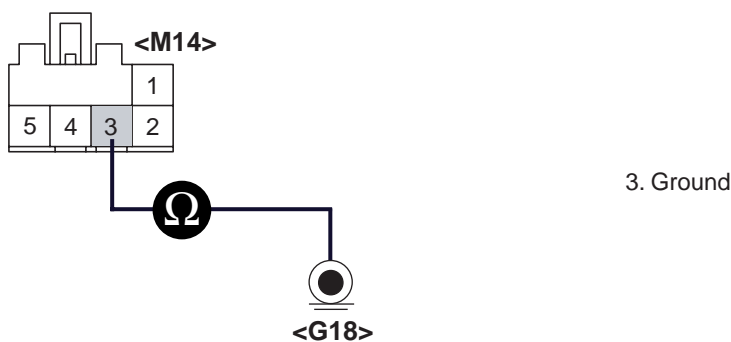

LTIF742J

- 4) Is the measured resistance within specifications?

**YES**

Go to "Component Inspection" procedure.

**NO**

Check for open in ground harness.

Make sure that Chassis ground G18 is firmly tightened properly.

Repair as necessary and go to "Verification of Vehicle Repair" procedure.

[ 2.0 ENGINE]

1. Check for open in harness between SMARTRA and ECM.
  - 1) Ignition "OFF".
  - 2) Disconnect SMARTRA connector.
  - 3) Measure resistance between terminal 3 of the SMARTRA harness connector and terminal 71 of ECM harness connector.

Specification : Approx. below 1

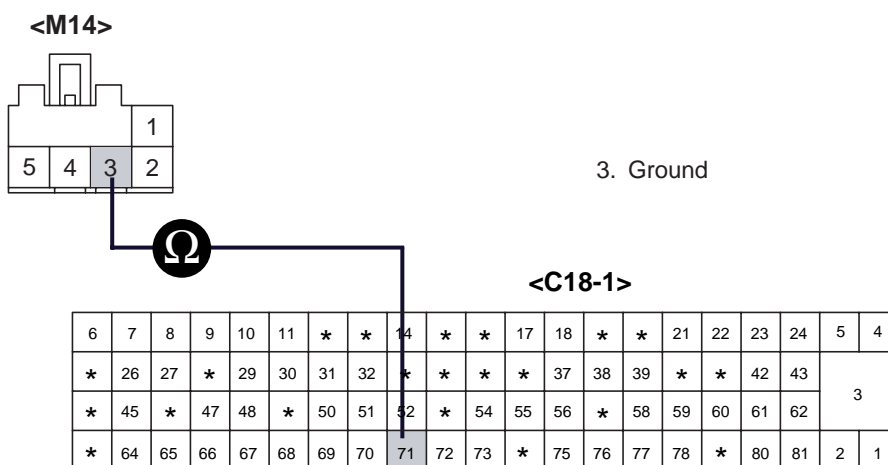

LTIF743C

- 4) Is the measured resistance within specifications?

**YES**

Go to "Component Inspection" procedure.

**NO**

Check for open in ground harness.

Repair as necessary and go to "Verification of Vehicle repair" procedure.

COMPONENT INSPECTION E4AF76EF

[D2.0 ENGINE]

1. Check Antenna Coil
  - 1) Ignition " OFF".
  - 2) Disconnect SMARTRA connector.
  - 3) Measure resistance between terminal 1 and 2 of the SMARTRA harness connector.

---

Specification : Approx. 8.6

---



LTIF742K

- 4) Is the measured resistance within specifications?

**YES**

Go to " Check SMARTRA" as below.

**NO**

Check for open or short in harness between SMARTRA and Antenna coil, repair or replace as necessary. And then, go to "Verification of Vehicle Repair" procedure.

2. Check SMARTRA

- 1) Ignition " ON" & Engine "OFF".
- 2) Perform the Neutral, Teaching, and Password teaching/ changing mode according to 2. ECM neutralization, 3.Key Teaching Procedure, 4. Password teaching/Changing in "Reference Data" described in General Information.

 **NOTE**

*Be sure that PIN code is prepared before performing neutral mode.*

- 3) Is Key teaching completed?

**YES**

Go to "Verification of Vehicle Repair" procedure.

**NO**

Substitute with a known-good SMARTRA and check for proper operation. If the problem is corrected, replace SMARTRA and go to "Check ECM" as below.

 **NOTE**

*In case of faulty SMARTRA, there are no special procedures required. A new SMARTRA device simply replaces the old one. (There are no transponder-related data stored in this device.)*

3. Check ECM

- 1) Ignition " ON" & Engine "OFF".
- 2) Perform Key Teaching Procedure in "Reference Data" described in General Information.
- 3) Is the Key teaching completed?

**YES**

Thoroughly check connectors for looseness, poor connection, bending, corrosion, contamination, deterioration, or damage. Repair or replace as necessary and then go to " Verification of Vehicle Repair" procedure.

**NO**

Substitute with a known-good ECM and check for proper operation. If the problem is corrected, replace ECM and then go to " Verification of Vehicle repair" procedure.

 **NOTE**

1. *Don't forget to prepare for the PIN of the vehicle before removing ECM from the vehicle.*
2. *Remember that substituting with a known-good ECM should be followed "The things to remember before repair(1)" in "Reference Data in General Information".  
(In case of faulty ECM, it has to be replaced with "VIRGIN" or " NEUTRAL" ECM.)*
3. *Strongly recommend to register PIN which is given by KMC or the regional office when replacing a new ECM.*

[ 2.0 ENGINE]

1. Check SMARTRA

- 1) Ignition " ON" & Engine "OFF".
- 2) Perform neutral mode, key teaching/changing and password teaching according to description in "System inspection" procedure.

 **NOTE**

*Be sure that PIN code is prepared before performing neutral mode.*

- 3) Is Key teaching completed?

**YES**

Go to " Check ECM " as below.

**NO**

Substitute with a known-good SMARTRA and check for proper operation. If the problem is corrected, replace SMARTRA and Go to "Verification of Vehicle Repair" procedure.

 **NOTE**

*In case of faulty SMARTRA, there are no special procedures required. A new SMARTRA device simply replaces the old one. (There are no transponder-related data stored in this device.)*

2. Check ECM

- 1) Ignition " ON" & Engine "OFF".
- 2) Perform Key teaching/changing mode again.
- 3) Is the Key teaching completed?

**YES**

Go to "Verification of Vehicle Repair" procedure.

**NO**

Substitute with a known-good ECM and check for proper operation. If the problem is corrected, replace ECM and then go to " Verification of Vehicle repair" procedure.

 **NOTE**

1. *Don't forget to prepare for the PIN of the vehicle before removing ECM from the vehicle.*
2. *Remember that substituting with a known-good ECM should be followed "The things to remember before repair(1)" in "System Inspection" procedure. (In case of faulty ECM, it has to be replaced with "VIRGIN" or "NEUTRAL" ECM.)"*
3. *Strongly recommend to register PIN which is given by KMC or the regional office when replacing a new ECM.*

**VERIFICATION OF VEHICLE REPAIR** E44DFA03

After a repair, it is essential to verify that the fault has been corrected.

1. Connect scan tool and monitor CURRENT DATA to check No. of Learnt key, ECM and KEY status.
2. Select Diagnostic Trouble Codes(DTCs)" mode and Clear the DTCs.
3. Are any DTCs present?

**YES**

Go to the applicable troubleshooting procedure.

**NO**

System is performing to specification at this time.

**DTC P1691 ANTENNA COIL ERROR**

**GENERAL DESCRIPTION** E72EBDEF

[ 2.0 ENGINE]

This wireless communication runs on RF . The SMARTRA is mounted at the ignition lock close to the antenna coil for RF transmission and receiving. The RF signal from the transponder received by the antenna coil is converted into messages for serial communication by the SMARTRA device. And the received messages from the EMS are converted into an RF signal, which is transmitted, to the transponder by the antenna.

[ 2.7 ENGINE]

The coil antenna has the following functions.

1. The coil antenna supplies energy to the transponder.
2. The coil antenna receives signal from the transponder.
3. The coil antenna sends transponder signal to the ICU.

It is located directly in front of the steering handle lock.

**DTC DESCRIPTION** E9CCFC3A

This DTC is defined as Antenna coil open or short circuit.

**DTC DETECTING CONDITION** E62AB99B

[ 2.0 ENGINE]

Item	Detecting Condition	Possible cause
Enable Condition	• IG ON	• Open or short in coil circuit • Faulty Antenna Coil • Faulty SMARTRA • Faulty ECM
Detecting factors	• Antenna signal error	
Detecting Window	• Before transponder communications	
Detecting Criteria	• Antenna open/short circuit	

[ 2.7 ENGINE]

Item	Detecting Condition	Possible cause
Enable Condition	• IG ON	• Open or short in coil circuit • Faulty Antenna Coil
Detecting factors	• Antenna signal error	
Detecting Window	• Before transponder communications	
Detecting Criteria	• Antenna open/short circuit	



## IGNITION SYSTEM

BE -221

### TERMINAL AND CONNECTOR INSPECTION EDD245B6

#### [ 2.0 ENGINE]

Refer to DTC P1690.

#### [ 2.7 ENGINE]

1. Many malfunctions in the electrical system are caused by poor harness(es) and terminals. Faults can also be caused by interference from other electrical systems and mechanical or chemical damage.
2. Thoroughly check connectors for looseness, poor connection, bending, corrosion, contamination, deterioration, or damage.
3. Has a problem been found?

**YES**

Repair as necessary and then go to "Verification of Vehicle Repair" procedure.

**NO**

Go to "Control Circuit Inspection" procedure.

### POWER SUPPLY CIRCUIT INSPECTION EE6D5BB2

#### [ 2.0 ENGINE]

Refer to DTC P1690.

### SIGNAL CIRCUIT INSPECTION EE650FB4

#### [ 2.0 ENGINE]

Refer to DTC P1690.

### GROUND CIRCUIT INSPECTION ECFD546E

#### [ 2.0 ENGINE]

Refer to DTC P1690.

### CONTROL CIRCUIT INSPECTION E1E07BD3

#### [ 2.7 ENGINE]

1. Ignition "OFF".
2. Disconnect ICU and Antenna coil connector.

3. Measure resistance between terminal "1(3)" of the ICU harness and "2(1)" of the Antenna coil harness.

Specification : Approx. 0

 **NOTE**

ICM energizes antenna coil from Antenna coil (+) to Antenna coil (-).

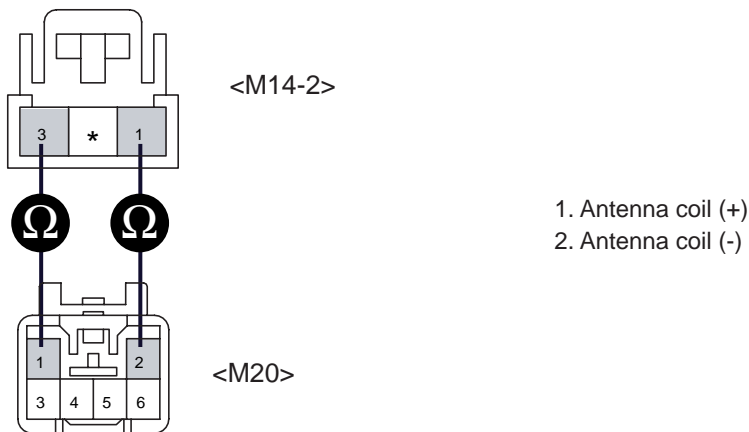

LTIF743I

4. Are measured resistances within specification?

**YES**

Go to "Component Inspection" procedure.

**NO**

Check for open or short in signal harness. Repair as necessary and then go to "Verification of Vehicle Repair" procedure.

**COMPONENT INSPECTION** ECDEF30C

[ 2.0 ENGINE ]

1. Check Antenna Coil
  - 1) Ignition " OFF".
  - 2) Disconnect SMARTRA connector.

- 3) Measure resistance between terminal 1 and 2 of the SMARTRA connector (Component side)

Specification : Approx. 8.6

<M14>

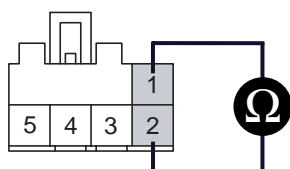

1. Antenna coil(+)
2. Antenna coil(-)

LTIF743F

- 4) Is the measured resistance within specifications?

**YES**

Go to " Check SMARTRA" as below.

**NO**

Substitute with a known-good Antenna Coil and check for proper operation. If the problem is corrected, replace Antenna Coil. And then, go to "Verification of Vehicle Repair" procedure.

2. Check SMARTRA

- 1) Ignition " ON" & Engine "OFF".
- 2) Perform neutral mode, key teaching/changing and password teaching according to description in "System inspection" procedure.

 **NOTE**

Be sure that PIN code is prepared before performing neutral mode.

- 3) Is Key teaching completed?

**YES**

Go to "Verification of Vehicle Repair" procedure.

**NO**

Substitute with a known-good SMARTRA and check for proper operation. If the problem is corrected, replace SMARTRA and Go to "Verification of Vehicle Repair" procedure.

 **NOTE**

In case of faulty SMARTRA, there are no special procedures required. A new SMARTRA device simply replaces the old one. (There are no transponder-related data stored in this device.)

[ 2.7 ENGINE]

1. Check antenna coil
  - 1) Ignition "OFF".
  - 2) Disconnect Antenna coil connector.
  - 3) Measure resistance between terminal "1" and "2" of the Antenna coil harness.

---

Specification : Approx. 7.5

---

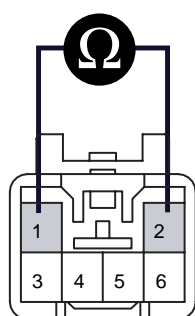

1. Antenna coil (+)
2. Antenna coil (-)

LTIF743J

- 4) Is measured resistance within specification?

**YES**

Thoroughly check connectors for looseness, poor connection, bending, corrosion, contamination, deterioration, or damage.

Repair or replace as necessary and then go to "Verification of Vehicle Repair" procedure.

**NO**

Substitute with a known-good Antenna Coil and check for proper operation.

If the problem is corrected, replace Antenna Coil and then go to "Verification of Vehicle Repair" procedure.

**VERIFICATION OF VEHICLE REPAIR** ECD547FC

Refer to DTC P1690.

**DTC P1692 IMMOBILIZER LAMP ERROR**

**GERNERAL DESCRIPTION**

E44635E1

The driver is informed about successful authentication by immobilizer lamp at dashboard. The lamp is "ON" after successful authentication until the detection of minimum engine speed for ECM operation (begin of engine cranking).

After the IG ON, the Immobilizer lamp will be turned ON for 30 seconds then, goes off if the immobilizer system is O.K. In case of the immobilizer system is failed, the immobilizer lamp will be blinking for 5 times then goes off.

**DTC DESCRIPTION**

ED0FBC2F

This DTC will be resulting from the Immobilizer Lamp error or Non-immobilizer ECM causing No communication between Scanner and Immobilizer.

**DTC DETECTING CONDITION**

E14A00AD

Item	Detecting Condition	Possible cause
Enable Condition	• IG ON	• Short in Lamp circuit
Detecting Criteria	• Line : Short circuit	

**SYSTEM INSPECTION**

E04C6549

1. Ignition "ON" & Engine "OFF".
2. Check Immobilizer indicator lamp.

 **NOTE**

1. *Normal Condition : After the IG ON, the Immobilizer lamp will be turned ON for 30 seconds then, goes off if the immobilizer system is O.K.*
  2. *Malfunction on Immobilizer system : The immobilizer lamp will be blinking for 5 times then goes off.*
3. Is the immobilizer lamp operating correctly?

**YES**

Fault is intermittent caused by poor contact in the lamp's and/or ECM's connector or was repaired and ECM memory was not cleared. Thoroughly check connectors for looseness, poor connection, bending, corrosion, contamination, deterioration, or damage. Repair or replace as necessary and then go to " Verification of Vehicle Repair" procedure.

**NO**

Go to " Component Inspection" procedure.

**COMPONENT INSPECTION** EEC0CBD5

1. Check Immobilizer indicator control
  - 1) Ignition "OFF".
  - 2) Disconnect ECM connector.
  - 3) Ignition "ON" & Engine "OFF".
  - 4) Measure voltage between terminal 17 of ECM harness connector and chassis ground.

Specification : Approx. 11V

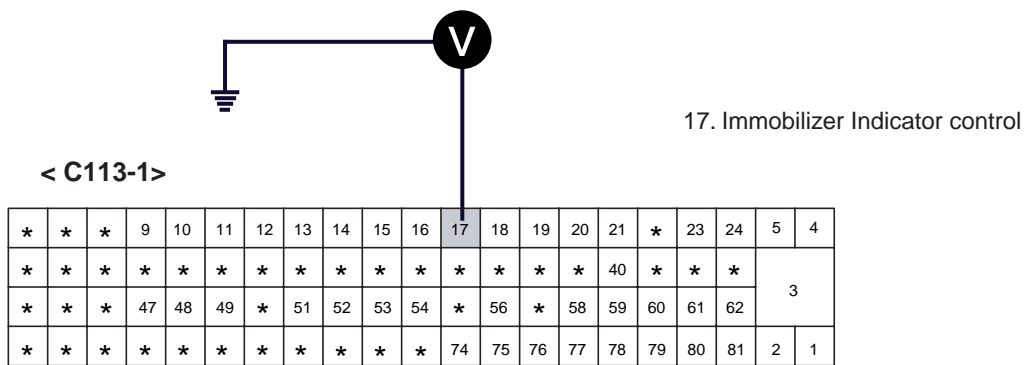

LTIF743D

- 5) Is the measured voltage within specifications?

**YES**

Go to " Check Immobilizer indicator bulb" as below.

**NO**

Check for short to battery in the control circuit.

Repair or replace as necessary and then, go to "Verification of Vehicle Repair" procedure.

## IGNITION SYSTEM

BE -227

2. Check Immobilizer bulb
  - 1) Ignition " OFF".
  - 2) Disconnect ECM connector.
  - 3) Jump between terminal 17 of ECM harness connector and Chassis ground with jumper wire.
  - 4) Ignition "ON" and Engine "OFF".

---

Specification : Immobilizer lamp "ON".

---

- 5) Is the Immobilizer indicator lamp turned "ON"?

**YES**

Substitute with a known-good ECM and check for proper operation. If the problem is corrected, replace ECM and then go to " Verification of Vehicle repair" procedure.

 **NOTE**

1. Don't forget to prepare for the PIN of the vehicle before removing ECM from the vehicle.
2. Remember that substituting with a known-good ECM should be followed "The things to remember before repair(1) in "Reference Data in General Information" (In case of faulty ECM, it has to be replaced with "VIRGIN" or " NEUTRAL" ECM.)
3. Strongly recommend to register PIN which is given by KMC or the regional office when replacing a new ECM.

**NO**

Repair or replace as necessary and then, go to "Verification of Vehicle Repair" procedure.

## VERIFICATION OF VEHICLE REPAIR EEF9C5A3

After a repair, it is essential to verify that the fault has been corrected.

1. Connect scan tool and monitor CURRENT DATA to check No. of Learnt key, ECM and KEY status.
2. Select Diagnostic Trouble Codes(DTCs)" mode and Clear the DTCs.
3. Are any DTCs present?

**YES**

Go to the applicable troubleshooting procedure.

**NO**

System is performing to specification at this time.

**DTC P1693 TRANSPONDER NO RESPONSE ERROR / INVALID RESPONSE**

**GENERAL DESCRIPTION** EECF9660

**[D2.0, 2.0 ENGINE]**

During the key teaching procedure the transponder will be programmed with vehicle specific data. The vehicle specific data are written into the transponder memory. The write procedure is unique; therefore the content of transponder can never be modified or changed. The data are a string of 9 bytes defined by vehicle manufacturer.

The transponder memory is split into two strings called authenticator and key password. After this programming the transponder memory is locked and the data (PIN code) cannot be read or changed respectively. The transponder status changes from "virgin" to "learnt". Additionally every transponder includes a unique IDE (Identifier number) of 32 bit. Unique means that the IDE of all transponder is different from each other. The IDE is programmed by the transponder manufacturer and is a read-only value. The authenticator and the key password are not transferred from ECM to transponder or vice versa. Only the results from the encryption algorithm are transferred. It is almost impossible to calculate the vehicle specific data from the encryption result.

For teaching of keys and special purposes the ECM is connected to the tester device.

When IG is ON, the coil supplies energy to the transponder which in turn accumulates energy in the condenser. Once the energy supply from the coil has stopped, using the stored energy in the condenser, the transponder transmits the ID CODE (stored within the ASIC).

**[ 2.7 ENGINE]**

A transponder is incorporated in the head section of the key. The antenna coil supplies energy to the transponder. The transponder accumulates energy in the condenser. Once the energy supply from the coil has stopped, using the stored energy in the condenser, the transponder transmits the ID CODE (stored within the ASIC).

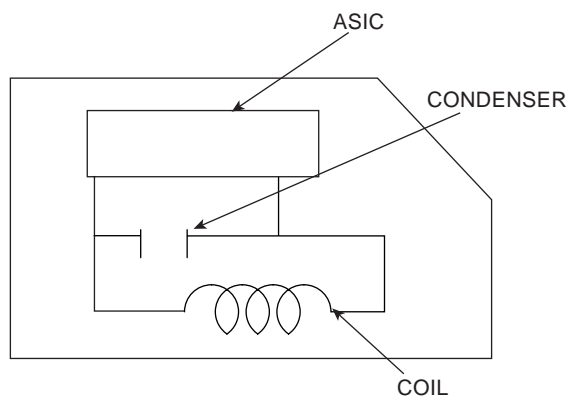

LTIF743K

When Ignition is set 'ON' the ICM receives a request signal from the ECM and starts ID Code registering sequence. If the ID code format from the transponder is not correct, the ICM repeatedly performs the registering sequence.

When the correct ID code format is registered, the code is verified by the ICM. If the code is not verified, the registering sequence is repeated a maximum of 5 times which is equivalent to 1 second duration.

Once the correct ID code is registered and verified after Ignition is turned ON, the registering sequence is not reperformed until Ignition is turned OFF.

**IGNITION SYSTEM**

**DTC DESCRIPTION** EB712EDD

**[D2.0 ENGINE]**

This DTC is defined as Invalid Transponder Data and Password mode invalid.

**[ 2.0 ENGINE]**

This DTC is defined as Invalid Transponder Data , Transponder program error and Password mode invalid.

**[ 2.7 ENGINE]**

This DTC is defined as Invalid(More than one TP or No TP in the magnetic field) Transponder Data.

**DTC DETECTING CONDITION** E64ABD5C

**[D2.0 ENGINE]**

Item		Detecting Condition	Possible cause
Enable Condition		<ul style="list-style-type: none"><li>• IG ON</li></ul>	<ul style="list-style-type: none"><li>• Transponder Key</li></ul>
Detecting Factors		<ul style="list-style-type: none"><li>• Invalid Transponder Data (Invalid TP EEPROM page contents after 3 attempts by ECM) (Case 1)</li><li>• Password mode invalid (Case 2)</li></ul>	
Case 1	Detecting Window	<ul style="list-style-type: none"><li>• During Transponder IDE</li><li>• During Transponder Authentication requests</li><li>• During Transponder Write EEPROM page requests</li><li>• During Transponder Read EEPROM page requests</li></ul>	
	Detecting Criteria	<ul style="list-style-type: none"><li>• Corrupted data form Transponder (Tp), or more than one TP in the field, or no TP in the field.</li></ul>	
Case 2	Detecting Window	<ul style="list-style-type: none"><li>• During Transponder Write or Read EEPROM Page.</li></ul>	
	Detecting Criteria	<ul style="list-style-type: none"><li>• TP not in password mode, or Transponder transport data has been changed.</li></ul>	

[ 2.0 ENGINE]

Item		Detecting Condition	Possible cause
Enable Condition		<ul style="list-style-type: none"> <li>• IG ON</li> </ul>	<ul style="list-style-type: none"> <li>• Transponder Error</li> <li>• Faulty SMARTRA</li> <li>• Faulty ECM</li> </ul>
Detecting Factors		<ul style="list-style-type: none"> <li>• Invalid Transponder Data (Case 1)</li> <li>• Transponder Program Error (Case 2)</li> <li>• Password mode invalid (Case 3)</li> </ul>	
Case 1	Detecting Window	<ul style="list-style-type: none"> <li>• During Transponder IDE</li> <li>• During Transponder Authentication requests</li> <li>• During Transponder Write EEPROM page requests</li> <li>• During Transponder Read EEPROM page requests</li> </ul>	
	Detecting Criteria	<ul style="list-style-type: none"> <li>• Corrupted data form Transponder (Tp), or more than one TP in the field, or no TP in the field.</li> </ul>	
Case 2	Detecting Window	<ul style="list-style-type: none"> <li>• During Transponder Write EEPROM Page request while transponder is in authorized state.</li> </ul>	
	Detecting Criteria	<ul style="list-style-type: none"> <li>• Corrupted data from Transponder(TP),or more than one TP in the field or no TP in the field.</li> </ul>	
Case 3	Detecting Window	<ul style="list-style-type: none"> <li>• During Transponder Write or Read EEPROM Page.</li> </ul>	
	Detecting Criteria	<ul style="list-style-type: none"> <li>• TP not in password mode, or Transponder transport data has been changed.</li> </ul>	

[ 2.7 ENGINE]

Item		Detecting Condition	Possible cause
Enable Condition		<ul style="list-style-type: none"> <li>• IG ON</li> </ul>	<ul style="list-style-type: none"> <li>• Faulty Transponder</li> </ul>
Detecting Factors		<ul style="list-style-type: none"> <li>• Transponder error</li> </ul>	
Detecting Window		<ul style="list-style-type: none"> <li>• During Transponder IDE</li> <li>• During Transponder Authentication requests</li> <li>• During Transponder Write EEPROM page requests</li> <li>• During Transponder Read EEPROM page requests</li> </ul>	
Detecting Criteria		<ul style="list-style-type: none"> <li>• Corrupted data form Transponder (Tp), or more than one TP in the field, or no TP in the magnetic field.</li> </ul>	

**MONITOR SCANTOOL DATA** EC90D19D

[D2.0, 2.0 ENGINE]

Refer to DTC P1690.

[ 2.7 ENGINE]

1. Ignition "ON" & Engine "OFF".
2. After connecting Scantool, Monitor the DTCs and CURRENT DATA to check key status.

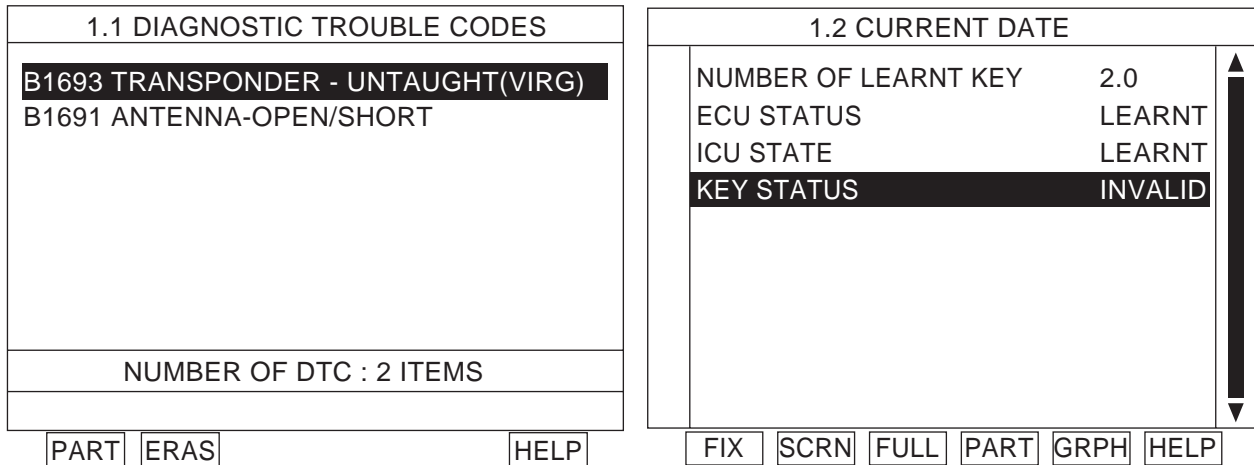

LTIF743E

**NOTE**

When DTC P1693 occurs, DTC P1691 can be displayed simultaneously.

3. Are DTSs and CURRENT DATA displayed as above when using another virgin or learnt key?

**YES**

If key status not changed from "invalid" to "virgin or learnt", This is not transponder(key) problem. Check for "antenna coil(harness) refer to P1691 antenna error" and then go to "Verification of Vehicle repair" procedure.

**NO**

If key status changed from "invalid" to "virgin or learnt", Substitute with a known-good Transponder and check for proper operation.

If the problem is corrected, replace a virgin Transponder and then go to "Verification of Vehicle Repair" procedure.

**NOTE**

1. When replacing the key, it is necessary to teach the key.
2. Be sure that PIN code is prepared before performing key teaching.

**COMPONENT INSPECTION** E6CC9B3D

**[D2.0 ENGINE]**

1. Check Transponder

- 1) Ignition "ON" & Engine "OFF".
- 2) Perform neutral mode, key teaching and password teaching/changing according to "3. ECM Neutralization, 2. Key Teaching Procedure, 4. Password Teaching in Reference Data" described in General Information.

 **NOTE**

*Be sure that PIN code is prepared before performing neutral mode.*

- 3) Is the neutral, teaching and password teaching/changing mode completed?

**YES**

Thoroughly check connectors for looseness, poor connection, bending, corrosion, contamination, deterioration, or damage. Repair or replace as necessary and then go to "Verification of Vehicle Repair" procedure.

**NO**

Substitute with a known-good virgin Transponder and monitor CURRENT DATA.

If the key status is displayed as "Virgin", replace Transponder.

Refer to "7. things to remember before a repair(2)" and perform key teaching mode according to "2. Key Teaching Procedure belongs to Reference Data" described in General Information.

Go to "Verification of Vehicle Repair" procedure.

**[ 2.0 ENGINE]**

1. Check Transponder

- 1) Ignition "ON" & Engine "OFF".
- 2) Perform neutral mode, key teaching and password teaching/changing(Refer to "Reference Data in General Information").

 **NOTE**

*Be sure that PIN code is prepared before performing neutral mode.*

- 3) Is the neutral, teaching and password teaching/changing mode completed?

**YES**

Go to "Check SMARTRA" as below.

**NO**

Substitute with a known-good virgin Transponder and monitor CURRENT DATA.

If the key status is displayed as "Virgin", replace Transponder.

Perform key teaching mode ( Refer to things to remember before a repair(2) in " Reference Data"

Go to "Verification of Vehicle Repair" procedure.

2. Check SMARTRA

- 1) Ignition " ON" & Engine "OFF".
- 2) Perform the Neutral, Teaching, and Password teaching/ changing mode according to 2. ECM neutralization, 3.Key Teaching Procedure, 4. Password teaching/Changing in "Reference Data" described in General Information.

 **NOTE**

*Be sure that PIN code is prepared before performing neutral mode.*

- 3) Is Key teaching completed?

**YES**

Go to " Check ECM " as below.

**NO**

Substitute with a known-good SMARTRA and check for proper operation. If the problem is corrected, replace SMARTRA and Go to "Verification of Vehicle Repair" procedure.

 **NOTE**

*In case of faulty SMARTRA, there are no special procedures required. A new SMARTRA device simply replaces the old one. (There are no transponder-related data stored in this device.)*

3. Check ECM

- 1) Ignition " ON" & Engine "OFF".
- 2) Perform Key Teaching Procedure in "Reference Data" described in General Information.
- 3) Is the Key teaching completed?

**YES**

Go to "Verification of Vehicle Repair" procedure.

**NO**

Substitute with a known-good ECM and check for proper operation. If the problem is corrected, replace ECM and then go to " Verification of Vehicle repair" procedure.

 **NOTE**

1. *Don't forget to prepare for the PIN of the vehicle before removing ECM from the vehicle.*
2. *Remember that substituting with a known-good ECM should be followed "The things to remember before repair(1)" in "System Inspection" procedure. (In case of faulty ECM, it has to be replaced with "VIRGIN" or "NEUTRAL" ECM.)*
3. *Strongly recommend to register PIN which is given by KMC or the regional office when replacing a new ECM.*

**VERIFICATION OF VEHICLE REPAIR** E6F9926F

Refer to DTC P1690.

**DTC P1694 ECU SIGNAL ERROR**

**GENERAL DESCRIPTION** E2D1A228

The ECM and the SMARTRA communicate by dedicated line. During this communication of ECM and SMARTRA the K line of ECM cannot be used for communication. The ECM controls the communication either to SMARTRA or to other devices(e.g. scanner) on K line by switching of a multiplexer and specific communication procedures. The multiplexer is a part of ECM hard ware.

**DTC DESCRIPTION** ECD55437

This DTC is defined as invalid request from ECM or corrupted data.

**DTC DETECTING CONDITION** ED8FAD1B

Item	Detecting Condition	Possible cause
Enable Condition	<ul style="list-style-type: none"><li>• IG ON</li></ul>	<ul style="list-style-type: none"><li>• Faulty ECM</li></ul>
Detecting factors	<ul style="list-style-type: none"><li>• Request from Control unit is invalid</li></ul>	
Detecting Window	<ul style="list-style-type: none"><li>• ECM request message</li></ul>	
Detecting Criteria	<ul style="list-style-type: none"><li>• Protocol layer violation - Invalid request, Invalid check sum.)</li></ul>	

**MONITOR SCANTOOL DATA** E167E42C

Refer to DTC P1690.

**COMPONENT INSPECTION** E2F940D3

1. Check ECM

- 1) Ignition " ON" & Engine "OFF".
- 2) Perform Key Teaching Procedure in "Reference Data" described in General Information.
- 3) Is the Key teaching completed?

**YES**

Thoroughly check connectors for looseness, poor connection, bending, corrosion, contamination, deterioration, or damage. Repair or replace as necessary and then go to " Verification of Vehicle Repair" procedure.

**NO**

Substitute with a known-good ECM and check for proper operation. If the problem is corrected, replace ECM and then go to " Verification of Vehicle repair" procedure.

 **NOTE**

1. Don't forget to prepare for the PIN of the vehicle before removing ECM from the vehicle.
2. Remember that substituting with a known-good ECM should be followed "The things to remember before repair(1)" in "Reference Data in General Information".  
(In case of faulty ECM, it has to be replaced with "VIRGIN" or " NEUTRAL" ECM.)
3. Strongly recommend to register PIN which is given by KMC or the regional office when replacing a new ECM.

**VERIFICATION OF VEHICLE REPAIR** EED2E4CC

Refer to DTC P1690.

**DTC P1695 EMS MEMORY ERROR**

**GENERAL DESCRIPTION** EA9C6522

**[D2.0 ENGINE]**

The relevant data for the immobilizer function are stored at permanent memory (EEPROM or Flash etc.).

The immobilizer data are stored by three independent entries.

The data from EEPROM are evaluated by "2 of 3 decision". That means all three entries are read and the content is compared before authentication process.

If the contents of all entries are equal, the authentication will run without additional measures.

If only the contents of two entries are equal, the authentication will run and fault code "EEPROM defective" is stored at ECM.

If the contents of all three entries are different from each other, no authentication will be possible and the fault code "EEPROM defective" will be stored. The limp home function cannot be activated. The ECM shall be replaced if the EEPROM related fault occurs again after new teaching of all keys.

**[ 2.0 ENGINE]**

This DTC is defined as not only ECM have inconsistent data of EEPROM for number of keys taught, user password state and invalid write operation to EEPROM but ECM can not recognize the unique PIN code during Key Authentication.

**DTC DESCRIPTION** EBB6D72B

**[D2.0 ENGINE]**

This DTC is defined as not only ECM have inconsistent data of EEPROM for number of keys taught, user password state and invalid write operation to EEPROM but ECM can not recognize the unique PIN code during Key Authentication.

**[ 2.0 ENGINE]**

This DTC is defined as that ECM, indicator or scantool have some problem.

**DTC DETECTING CONDITION** EAD40E7F

**[D2.0 ENGINE]**

Item		Detecting Condition	Possible cause
Enable Condition		<ul style="list-style-type: none"><li>IG ON</li></ul>	<ul style="list-style-type: none"><li>Faulty ECM</li></ul>
Case 1	Detecting Criteria	<ul style="list-style-type: none"><li>ECM internal permanent memory(EEPROM or Flash etc.) fault.</li><li>Invalid write operation to permanent memory(EEPROM or Flash etc.) fault.</li></ul>	
Case 2	Detecting Criteria	<ul style="list-style-type: none"><li>Not plausible vehicle specific data stored at ECM or corrupted data for KEY IDE.</li><li>Virgin key at learnt ECM</li></ul>	

**[ 2.0 ENGINE]**

Item		Detecting Condition	Possible cause
Enable Condition		<ul style="list-style-type: none"><li>IG ON</li></ul>	<ul style="list-style-type: none"><li>Faulty ECM</li></ul>
Detecting Criteria	EEPROM	<ul style="list-style-type: none"><li>Inconsistent data of EEPROM</li><li>Invalid write operation to EEPROM</li></ul>	

## IGNITION SYSTEM

BE -237

### MONITOR SCANTOOL DATA E D F F 0 A 1 C

Refer to DTC P1690.

### COMPONENT INSPECTION E 6 A C A E 9 7

#### 1. Check ECM

- 1) Ignition " ON" & Engine "OFF".
- 2) Perform the Neutral, Teaching, and Password teaching/ changing mode according to 2. ECM neutralization, 3.Key Teaching Procedure, 4. Password teaching/Changing in "Reference Data" described in General Information.
- 3) Are both neutral and teaching mode completed?

**YES**

Thoroughly check connectors for looseness, poor connection, bending, corrosion, contamination, deterioration, or damage.

Repair or replace as necessary and then go to "Verification of Vehicle Repair" procedure.

**NO**

Substitute with a known-good ECM and check for proper operation. If the problem is corrected, replace ECM and then go to " Verification of Vehicle repair" procedure.

#### **NOTE**

1. *Don't forget to prepare for the PIN of the vehicle before removing ECM from the vehicle.*
2. *Remember that substituting with a known-good ECM should be followed "The things to remember before repair(1) in "Reference Data in General Information" (In case of faulty ECM, it has to be replaced with "VIRGIN" or " NEUTRAL" ECM.)*
3. *Strongly recommend to register PIN which is given by KMC or the regional office when replacing a new ECM.*

### VERIFICATION OF VEHICLE REPAIR E 2 C 6 D 7 E D

Refer to DTC P1690.

**DTC P1696 AUTHENTICATION FAIL**

**GENERAL DESCRIPTION** E25E1D9F

**[D2.0 ENGINE]**

The relevant data for the immobilizer function are stored at permanent memory (EEPROM or Flash etc.). The immobilizer data are stored by three independent entries. The data from EEPROM are evaluated by "2 of 3 decision". That means all three entries are read and the content is compared before authentication process. If the contents of all entries are equal, the authentication will run without additional measures. If only the contents of two entries are equal, the authentication will run and fault code "EEPROM defective" is stored at ECM. If the contents of all three entries are different from each other, no authentication will be possible and the fault code "EEPROM defective" will be stored. The limp home function cannot be activated. The ECM shall be replaced if the EEPROM related fault occurs again after new teaching of all keys.

**[ 2.0 ENGINE]**

The ECM and the SMARTRA communicate by dedicated line. During this communication of ECM and SMARTRA the K line of ECM cannot be used for communication. The ECM controls the communication either to SMARTRA or to other devices(e.g. scanner) on K line by switching of a multiplexer and specific communication procedures. The multiplexer is a part of ECM hard ware.

**DTC DESCRIPTION** E4FD5A1F

**[D2.0 ENGINE]**

This DTC is defined as Virgin TP or Invalid TP with "Learnt" ECM status (Authentication fail). Refer to the Authentication Flow Chart described in System Inspection Procedure.

**[ 2.0 ENGINE]**

This DTC is defined as that ECM, indicator or scantool have some problem.

**DTC DETECTING CONDITION** EB81A7FA

**[D2.0 ENGINE]**

Item	Detecting Condition	Possible cause
Enable Condition	<ul style="list-style-type: none"><li>IG ON</li></ul>	<ul style="list-style-type: none"><li>Faulty ECM</li></ul>
Detecting Criteria	<ul style="list-style-type: none"><li>Authentication Failure after 3 attempts by ECM</li></ul>	

**[ 2.0 ENGINE]**

Item	Detecting Condition	Possible cause
Enable Condition	<ul style="list-style-type: none"><li>IG ON</li></ul>	<ul style="list-style-type: none"><li>Scantool Error</li><li>Faulty Transponder</li><li>Faulty SMARTRA</li><li>Faulty ECM</li></ul>
Immobilizer indicator or ECM Faults	<ul style="list-style-type: none"><li>Not plausible VSS data stored at ECM.</li><li>Virgin key at Learnt ECM.</li><li>No valid data from SMARTRA after 3 attempts by ECM.</li><li>Invalid tester message or unexpected requests by tester(e.g. exceeding the maximum limit of twice IG ON or teaching trials)</li></ul>	

## IGNITION SYSTEM

BE -239

### MONITOR SCANTOOL DATA E3A6F2B0

Refer to DTC P1690.

### TERMINAL AND CONNECTOR INSPECTION E32DC164

[ 2.0 ENGINE]

Refer to DTC P1690.

### POWER SUPPLY CIRCUIT INSPECTION EE137423

[ 2.0 ENGINE]

Refer to DTC P1690.

### SIGNAL CIRCUIT INSPECTION E7FFDE23

[ 2.0 ENGINE]

Refer to DTC P1690.

### GROUND CIRCUIT INSPECTION E0EF3DDC

[ 2.0 ENGINE]

Refer to DTC P1690.

**COMPONENT INSPECTION** E921276D

**[D2.0 ENGINE]**

Refer to DTC P1695.

**[ 2.0 ENGINE]**

1. Check Transponder
  - 1) Ignition "ON" & Engine "OFF".
  - 2) Perform neutral mode, key teaching and password teaching/changing.  
(Refer to "Reference Data in General Information")

 **NOTE**

Be sure that PIN code is prepared before performing neutral mode.

- 3) Is the neutral, teaching and password teaching/changing mode completed?

**YES**

Go to "Check Antenna Coil" as below.

**NO**

Substitute with a known-good virgin Transponder and monitor CURRENT DATA.  
If the key status is displayed as "Virgin", replace Transponder.  
Perform key teaching mode ( Refer to things to remember before a repair(2) in " Reference Data"  
Go to "Verification of Vehicle Repair" procedure.

2. Check Antenna Coil
  - 1) Ignition " OFF".
  - 2) Disconnect SMARTRA connector.
  - 3) Measure resistance between terminal 1 and 2 of the SMARTRA connector (Component side)

---

Specification : Approx. 8.6

---

<M14>

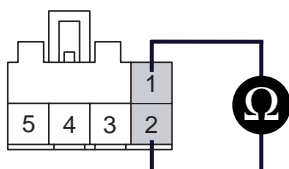

1. Antenna coil(+)
2. Antenna coil(-)

- 4) Is the measured resistance within specifications?

**YES**

Go to " Check SMARTRA" as below.

**NO**

Substitute with a known-good Antenna Coil and check for proper operation. If the problem is corrected, replace Antenna Coil. And then, go to "Verification of Vehicle Repair" procedure.

3. Check SMARTRA

- 1) Ignition " ON" & Engine "OFF".
- 2) Perform neutral mode, key teaching/changing and password teaching according to description in "System inspection" procedure.



*Be sure that PIN code is prepared before performing neutral mode.*

- 3) Is Key teaching completed?

**YES**

Fault is intermittent caused by poor contact in the SMARTRA and/or ECM's connector or was repaired and ECM memory was not cleared. Thoroughly check connectors for looseness, poor connection, bending, corrosion, contamination, deterioration, or damage. Repair or replace as necessary and then go to "Verification of Vehicle Repair" procedure.

**NO**

Substitute with a known-good SMARTRA and check for proper operation. If the problem is corrected, replace SMARTRA and go to "Check ECM" as below.



*In case of faulty SMARTRA, there are no special procedures required. A new SMARTRA device simply replaces the old one. (There are no transponder-related data stored in this device.)*

4. Check ECM

- 1) Ignition " ON" & Engine "OFF".
- 2) Perform Key teaching/changing mode again.
- 3) Is the 1st Key teaching completed?

**YES**

Go to "Verification of Vehicle Repair" procedure.

**NO**

Substitute with a known-good ECM and check for proper operation. If the problem is corrected, replace ECM and then go to " Verification of Vehicle repair" procedure.



**NOTE**

1. *Don't forget to prepare for the PIN of the vehicle before removing ECM from the vehicle.*
2. *Remember that substituting with a known-good ECM should be followed "The things to remember before repair(1)" in "System Inspection" procedure. (In case of faulty ECM, it has to be replaced with "VIRGIN" or "NEUTRAL" ECM.)*
3. *Strongly recommend to register PIN which is given by KMC or the regional office when replacing a new ECM.*

**VERIFICATION OF VEHICLE REPAIR** EEFE4D72

Refer to DTC P1690.

**DTC P1697 HI-SCAN MESSAGE ERROR**

**GENERAL DESCRIPTION** EEA2714D

The ECM and the SMARTRA communicate by dedicated line. During this communication of ECM and SMARTRA the K line of ECM cannot be used for communication. The ECM controls the communication either to SMARTRA or to other devices(e.g. scanner) on K line by switching of a multiplexer and specific communication procedures. The multiplexer is a part of ECM hard ware.

**DTC DESCRIPTION** ED4A6F6E

This DTC is defined as Invalid tester message or unexpected requests by tester and Locked by timer (e.g. exceeding the maximum limit of twice ignition On or teaching trials)

**DTC DETECTING CONDITION** ECDFFFB8

Item	Detecting Condition	Possible cause
Enable Condition	<ul style="list-style-type: none"><li>• IG ON</li></ul>	<ul style="list-style-type: none"><li>• Poor connection between Scanner and DLC(Data Link connector)</li><li>• Scanner Program Error</li><li>• Locked by timer (e.g. exceeding the maximum limit of twice ignition On or teaching trials)</li></ul>
Detecting Criteria	<ul style="list-style-type: none"><li>• Request from Tester is Invalid(Tester Error) : (Protocol layer violation - Invalid request, check sum error etc.)</li><li>• Locked by timer (e.g. exceeding the maximum limit of twice ignition On or teaching trials)</li></ul>	

**MONITOR SCANTOOL DATA** EBDFF09E

1. Ignition "ON" & Engine "OFF".
2. Connect Scan tool and clear the DTCs.
3. Monitor Current Data for Immobilizer System.
4. Retry to communication from the vehicle selection menu although once communication is failed.

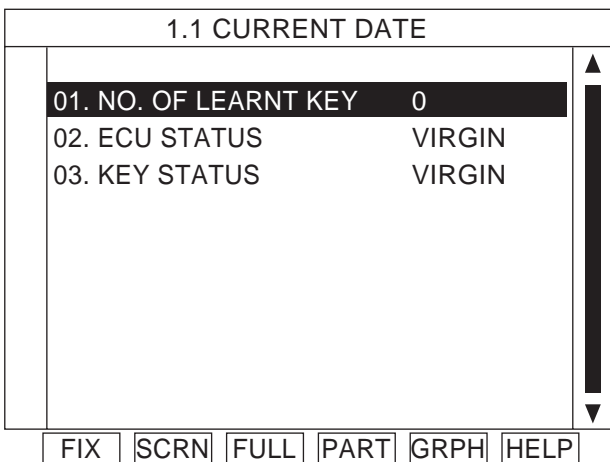

Fig 1

1.1 CURRENT DATE	
01. NO. OF LEARNT KEY	1
02. ECU STATUS	NOT CHECK
03. KEY STATUS	INVALID

FIX    SCR�N    FULL    PART    GRPH    HELP

Fig 2

LTIF742D

1.1 CURRENT DATE	
01. NO. OF LEARNT KEY	1
02. ECU STATUS	LEARNT
03. KEY STATUS	INVALID

FIX    SCR�N    FULL    PART    GRPH    HELP

Fig 3

LTIF742E

1.1 CURRENT DATE	
01. NO. OF LEARNT KEY	2
02. ECU STATUS	LEARNT
03. KEY STATUS	LEARNT

FIX    SCR�N    FULL    PART    GRPH    HELP

Fig 4

LTIF742F

- Fig 1 : ECM has not matched with any Key yet.
- Fig 2 : ECM Internal Failure.
- Fig 3 : IG On with unmatched key.
- Fig 4 : 2(two) Keys have been matched with ECM.

5. Is the communication possible between scan tool and Immobilizer system?

**YES**

In case that ECM status is locked, wait for one hour with IG Key On. Be sure that the battery is fully enough to stay for an hour with IG ON.

Repair or replace as necessary and then go to "Verification of Vehicle Repair" procedure.

**NO**

Check DLC cable connection between Scanner and DLC. And, update the program card with the latest version. Finally try communication between scan tool and Immobilizer system.

Substitute with a known-good scan tool and check for proper operation. If the problem is corrected, go to "Verification of Vehicle repair" procedure.

**VERIFICATION OF VEHICLE REPAIR** E34F52EA

Refer to DTC P1690.

**DTC P1698 INVALID TP (TP HAS DIFFERENT PIN)**

**GENERAL DESCRIPTION** E1A51A01

**[D2.0 ENGINE]**

Refer to DTC P1693.

**[ 2.7 ENGINE]**

Refer to DTC P1693.

**DTC DESCRIPTION** E7F309AD

**[D2.0 ENGINE]**

This DTC is defined as Virgin Key at Learnt ECM or Invalid Key IDE.

**[ 2.7 ENGINE]**

This DTC is defined as Invalid(virgin or invalid) Transponder Data.

**DTC DETECTING CONDITION** EE93C67B

**[D2.0 ENGINE]**

Item	Detecting Condition	Possible cause
Enable Condition	<ul style="list-style-type: none"><li>IG ON</li></ul>	<ul style="list-style-type: none"><li>Virgin Key at learnt ECM</li><li>Invalid Key</li></ul>
Detecting Factors	<ul style="list-style-type: none"><li>Invalid Key IDE after 3 attempts by ECM</li><li>Virgin Key at Learnt ECM</li></ul>	

**[ 2.7 ENGINE]**

Item	Detecting Condition	Possible cause
Enable Condition	<ul style="list-style-type: none"><li>IG ON</li></ul>	<ul style="list-style-type: none"><li>Faulty TP(Virgin or Invalid)</li></ul>
Detecting Factors	<ul style="list-style-type: none"><li>Invalid TP</li></ul>	
Detecting Criteria	<ul style="list-style-type: none"><li>Virgin TP at EMS STATUS "Learnt"</li><li>Learnt(Invalid) TP at EMS status "Learnt"(Authentication fail)</li></ul>	

MONITOR SCANTOOL DATA EEFEB5DA

[D2.0 ENGINE]

Refer to DTC P1690.

[ 2.7 ENGINE]

1. Ignition "ON" & Engine "OFF".
2. After connecting Scantool, Monitor the DTCs and CURRENT DATA to check key status.

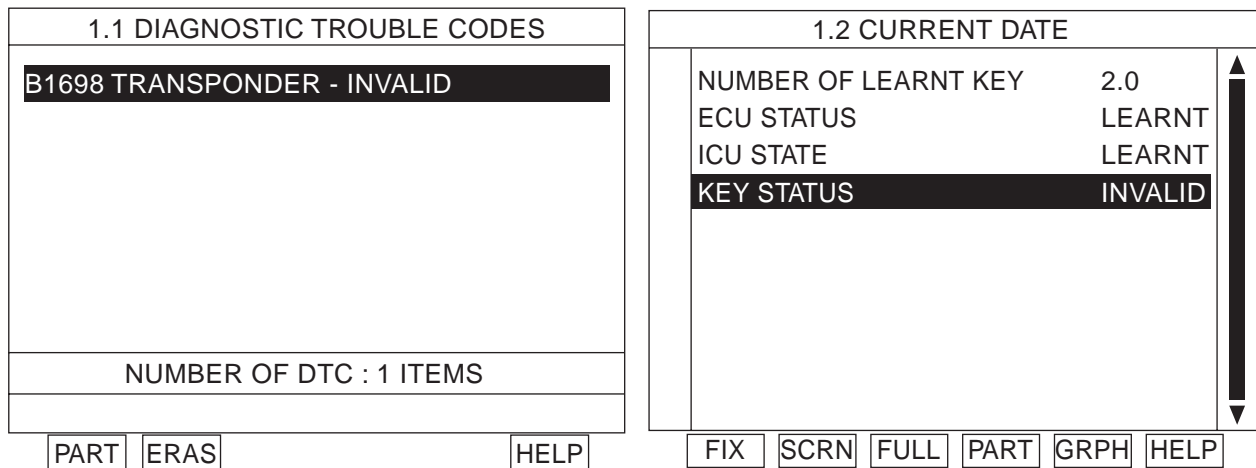

LTIF743G

3. Are DTSs and CURRENT DATA displayed as above?

**YES**

If key status is "invalid" is displayed, check transponder(key) and then go to "Verification of Vehicle Repair" procedure.

 **NOTE**

1. Be sure that P1698 is displayed, when transponder(key) is unintentionally exchanged with another key.
2. Be sure that P1698 is displayed, when using virgin transponder(key) with learnt ICU.
3. Be sure that P1698 is displayed by abnormal stop when key teaching is performed by learnt key(with same PIN code)

**NO**

Fault is intermittent caused by poor contact in the ICU and/or the antenna coil connector or was repaired and ICU memory was not cleared. Thoroughly check connectors for looseness, poor connection, bending, corrosion, contamination, deterioration, or damage.

Repair or replace as necessary and then go to "Verification of Vehicle Repair" procedure.

**SYSTEM INSPECTION** E413C990

**[D2.0 ENGINE]**

1. Ignition "ON" & Engine "OFF".
2. Perform Key Teaching Procedure in "Reference Data" described in General Information.
3. Is the TEACHING mode completed.

**YES**

4. Go to "Verification of Vehicle Repair" procedure.

**NO**

Substitute with a known-good virgin Transponder and monitor key status on CURRENT DATA.  
If the key status is displayed as "Virgin", replace Transponder.  
Perform teaching mode, go to "Verification of Vehicle Repair" procedure.

**VERIFICATION OF VEHICLE REPAIR** E08F457B

Refer to DTC P1690.