

EE-2

Engine Electrical System

General Information

Specifications

Ignition System

Items		Specification	
Ignition coil	Primary resistance	0.62 ± 10 %	
	Secondary resistance	7.0kΩ ± 15 %	
Spark plugs	Unleaded	NGK	IFR5G-11
		Gap	1.0 ~ 1.1 mm (0.0394 ~ 0.0433 in.)
	Leaed	NGK	BKR5ES
		Gap	0.8 ~ 0.9 mm (0.0315 ~ 0.0354 in)

Starting System

Items		Specification	
Starter	Rated voltage	12 V, 1.4 kW	
	No. of pinion teeth	8	
	No-load characteristics	Voltage	11.5 V
		Ampere	85A, MAX
		Speed	2,600 rpm, MIN

Charging System

Items		Specification
Alternator	Rate voltage	13.5 V, 130A
	Speed in use	1,000 ~ 18,000 rpm
	Voltage regulator	IC regulator built-in type
	Regulator setting voltage	12.4 ~ 14.8 V
Battery	Type	64 - 27 FL
	Cold cranking amperage [at -18°C(-0.4°F)]	660 A
	Reserve capacity	145 min
	Specific gravity [at 25°C(77°F)]	1.280 ± 0.01

NOTICE

- *COLD CRANKING AMPERAGE* is the amperage a battery can deliver for 30 seconds and maintain a terminal voltage of 7.2V or greater at a specified temperature.
- *RESERVE CAPACITY RATING* is amount of time a battery can deliver 25A and maintain a minimum terminal voltage of 10.5V at 26.7°C(80.1°F).

• Battery type notation:

□	□	-	□	□	□	□
①			②		③	④

- ① : 5HR capacity
- ② : Battery length
- ③ : Battery width
- ④ : Terminal location

SGKEE8100N

General Information

Troubleshooting

Ignition System

Symptom	Suspect area	Remedy
Engine will not start or is hard to start (Crank OK)	Ignition lock switch	Inspect ignition lock switch, or replace as required
	Ignition coil	Inspect ignition coil, or replace as required
	Spark plugs	Inspect spark plugs, or replace as required
	Ignition wiring disconnected or broken	Repair wiring, or replace as required
Rough idle or stalls	Ignition wiring	Repair wiring, or replace as required
	Ignition coil	Inspect ignition coil, or replace as required
Engine hesitates/poor acceleration	Spark plugs and spark plug cables	Inspect spark plugs / cable, or replace as required
	Ignition wiring	Repair wiring, or replace as required
Poor mileage	Spark plugs and spark plug cables	Inspect spark plugs / cable, or replace as required

Charging System

Symptom	Suspect area	Remedy
Charging warning indicator does not light with ignition switch "ON" and engine off.	Fuse blown	Check fuses
	Light burned out	Replace light
	Wiring connection loose	Tighten loose connection
	Electronic voltage regulator	Replace voltage regulator
Charging warning indicator does not go out with engine running. (Battery requires frequent recharging)	Drive belt loose or worn	Adjust belt tension or replace belt
	Battery cable loose, corroded or worn	Inspect cable connection, repair or replace cable
	Electronic voltage regulator or alternator	Replace voltage regulator or alternator
	Wiring	Repair or replace wiring
Overcharge	Electronic voltage regulator	Replace voltage regulator
	Voltage sensing wire	Repair or replace wiring
Discharge	Drive belt loose or worn	Adjust belt tension or replace belt
	Wiring connection loose or short circuit	Inspect wiring connection, repair or replace wiring
	Electronic voltage regulator or alternator	Replace voltage regulator or alternator
	Poor grounding	Inspect ground or repair
	Worn battery	Replace battery

EE-4

Engine Electrical System

Starting System

Symptom	Suspect area	Remedy
Engine will not crank	Battery charge low	Charge or replace battery
	Battery cables loose, corroded or worn out	Repair or replace cables
	Transaxle range switch (Vehicle with automatic transaxle only)	Refer to TR group-automatic transaxle
	Fuse blown	Replace fuse
	Starter motor faulty	Replace
	Ignition switch faulty	Replace
Engine cranks slowly	Battery charge low	Charge or replace battery
	Battery cables loose, corroded or worn out	Repair or replace cables
	Starter motor faulty	Replace
Starter keeps running	Starter motor	Replace
	Ignition switch	Replace
Starter spins but engine will not crank	Short in wiring	Repair wiring
	Pinion gear teeth broken or starter motor	Replace
	Ring gear teeth broken	Replace fly wheel or torque converter

Reference Service Tools

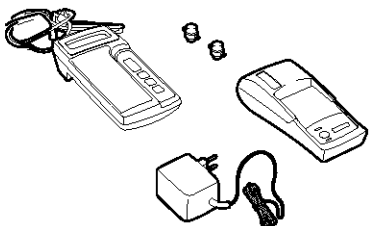
Tool (Number and name)	Illustration	Use
Micro-570 Battery checker	 LBLG001A	(Using with Terminal Printer_182-003A)

General Information

The Micro 570 Analyzer

The MICRO 570 Analyzer provides the ability to test the charging and starting systems, including the battery, starter and alternator.

⚠ CAUTION

Because of the possibility of personal injury, always use extreme caution and appropriate eye protection when working with batteries.

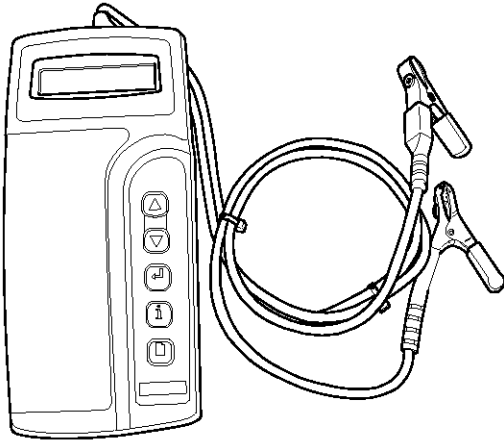

EBRF004A

Keypad

The MICRO570 button on the key pad provides the following functions :

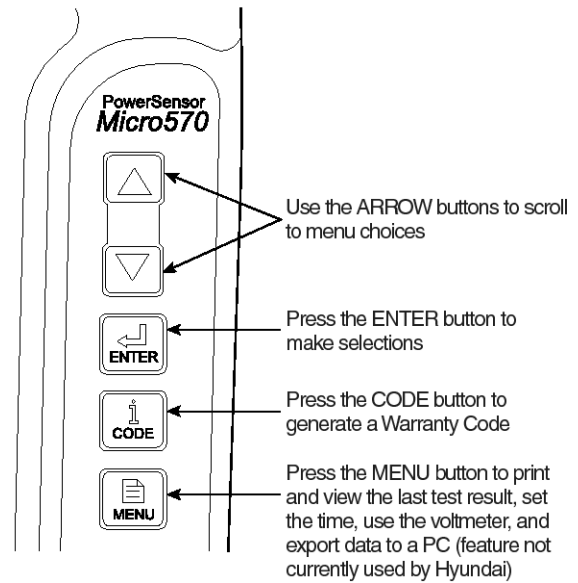

EBRF005A

EE-6

Engine Electrical System

Battery Test Procedure

1. Connect the tester to the battery.
 - Red clamp to battery positive (+) terminal.
 - Black clamp to battery negative (-) terminal.

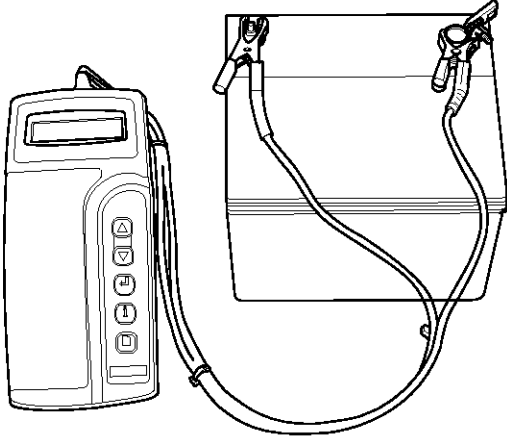

EBRF006A

CAUTION

Connect clamps securely. If "CHECK CONNECTION" message is displayed on the screen, reconnect clamps securely.

2. The tester will ask if the battery is connected "IN A VEHICLE" or "OUT OF A VEHICLE". Make your selection by pressing the arrow buttons; then press ENTER.

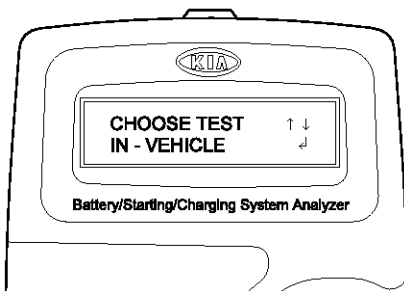

BBGE017A

3. Choose either CCA or CCP and press the ENTER button.

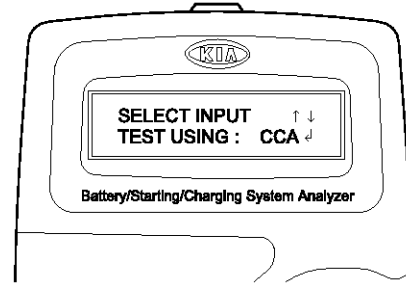

BBGE018A

NOTICE

- CCA : Cold cranking amps, is an SAE specification for cranking batteries at -18°C (0°F).
 - CCP : Cold cranking amps, is an SAE specification for korean manufacturer's for cranking batteries at -18°C (0°F).
4. Set the CCA value displayed on the screen to the CCA value marked on the battery label by pressing up and down buttons and press ENTER.

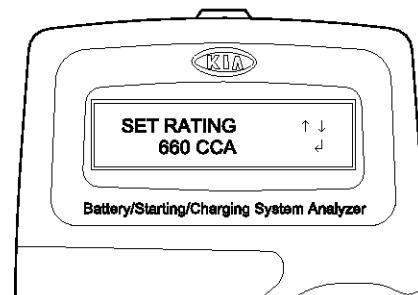

BBGE019A

NOTICE

The battery ratings(CCA) displayed on the tester must be identical to the ratings marked on battery label.

General Information

5. The tester (Micro570) displays battery test results including voltage and battery ratings.

A relevant action must be given according to the test results by referring to the battery test results as shown in the table below.

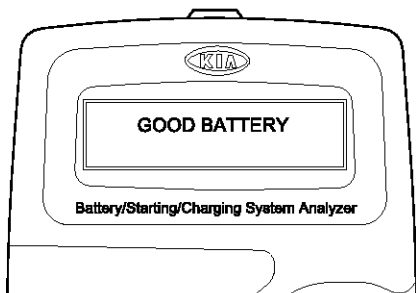

BBGE020A

NOTICE

The battery ratings (CCA) displayed on the tester must be identical to the ratings marked on battery label.

6. To conduct starter test, continuously, press ENTER.

Battery Test Results

Result On Printer	Remedy
Good battery	No action is required
Good recharge	Battery is in a good state Recharge by running engine 15 minutes at idle with on accessories on. Retest to assure Good.
Charge & Retest	Battery is not charged properly - Charge and test the battery again (Failure to charge the battery fully may read incorrect measurement value)
Replace battery	- Replace battery and recheck the charging system. (Improper connection between battery and vehicle cables may cause "REPLACE BATTERY", retest the battery after removing cables and connecting the tester to the battery terminal directly prior to replacing the battery)
Bad cell-replace	- Charge and retest the battery. And then, test results may cause "REPLACE BATTERY", replace battery and recheck the charging system

WARNING

Whenever filing a claim for battery, the print out of the battery test results must be attached.

EE-8

Engine Electrical System

Starter Test Procedure

1. After the battery test, press ENTER immediately for the starter test.

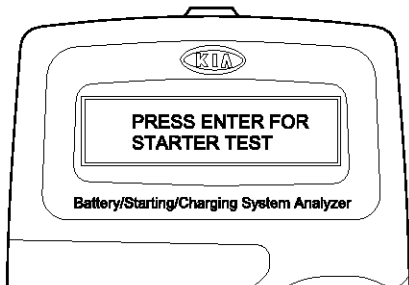

BBGE021A

2. After pressing ENTER key, start the engine.

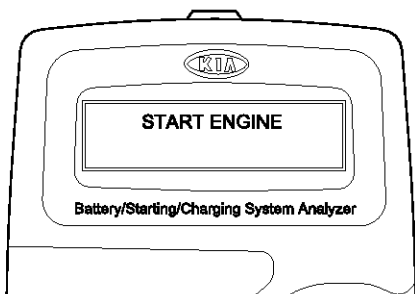

BBGE022A

3. Cranking voltage and starter test results will be displayed on the screen.

Take a relevant action according to the test results by referring to the starter test results as given below.

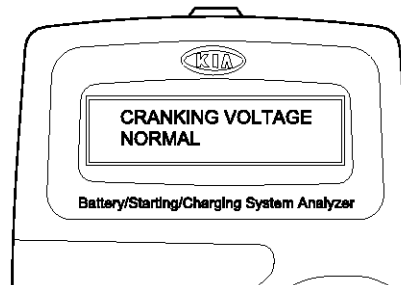

BBGE023A

4. To continue charging system test, press ENTER.

Starter Test Results

Result On Printer	Remedy
Cranking voltage normal	System shows a normal starter draw
Cranking voltage low	Cranking voltage is lower than normal level - Check starter
Charge battery	The state of battery charge is too low to test - Charge the battery and retest
Replace battery	- Replace battery - If the vehicle is not started though the battery condition of "Good and fully charged" is displayed. - Check wiring for open circuit, battery cable connection, starter and repair or replace as necessary. - If the engine does crank, check fuel system.

General Information

Charging System Test Procedure

1. Press ENTER to begin charging system test.

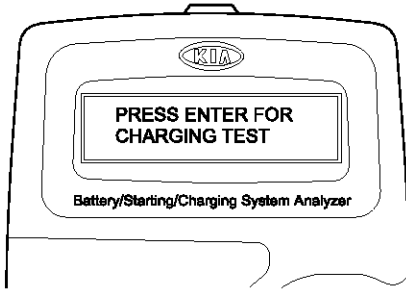

BBGE024A

2. ENTER button is pressed, the tester displays the actual voltage of alternator.
Press ENTER to test the charging system.

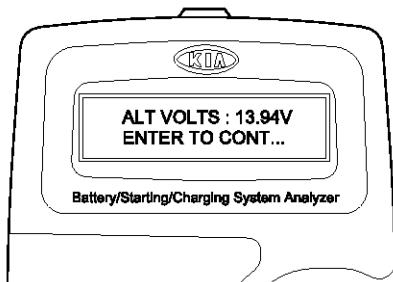

BBGE025A

3. Turn off all electrical load and rev engine for 5 seconds by pressing the accelerator pedal.

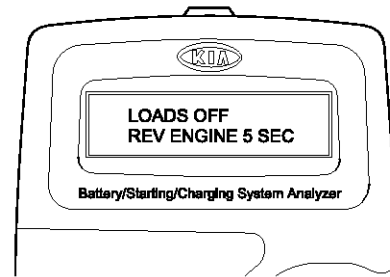

BBGE026A

4. Press ENTER.

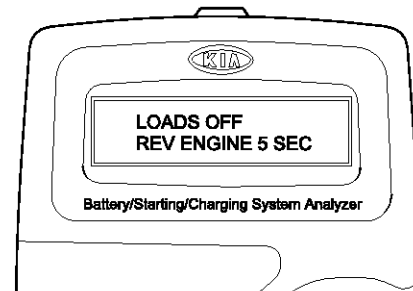

BBGE027A

EE-10

Engine Electrical System

5. The MICRO 570 analyzer charging system output at idle for comparison to other readings.

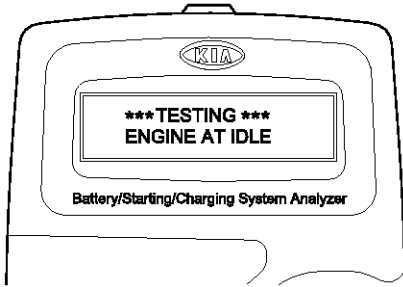

BBGE028A

6. Take a relevant action according to the test results by referring to the table below after shutting off the engine and disconnect the tester clamps from the battery.

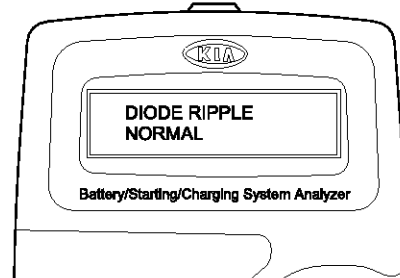

BBGE029A

Charging System Test Results

Result On Printer	Remedy
Charging system normal/ Diode ripple normal	Charging system is normal
No charging voltage	Alternator does not supply charging current to battery - Check belts, connection between alternator and battery Replace belts or cable or alternator as necessary
Low charging voltage	Alternator does not supply charging current to battery and electrical load to system fully - Check belts and alternator and replace as necessary
High charging voltage	The voltage from alternator to battery is higher than normal limit during voltage regulating. - Check connection and ground and replace regulator as necessary - Check electrolyte level in the battery
Excess ripple detected	One or more diodes in the alternator is not functioning properly - Check alternator mounting and belts and replace as necessary

Ignition System

Description

Ignition timing is controlled by the electronic control ignition timing system. The standard reference ignition timing data for the engine operating conditions are preprogrammed in the memory of the ECM (Engine Control Module).

The engine operating conditions (speed, load, warm-up condition, etc.) are detected by the various sensors. Based on these sensor signals and the ignition timing data, signals to interrupt the primary current are sent to the ECM. The ignition coil is activated, and timing is controlled.

On-vehicle Inspection

Spark Test

1. Remove the ignition coil connector(A).

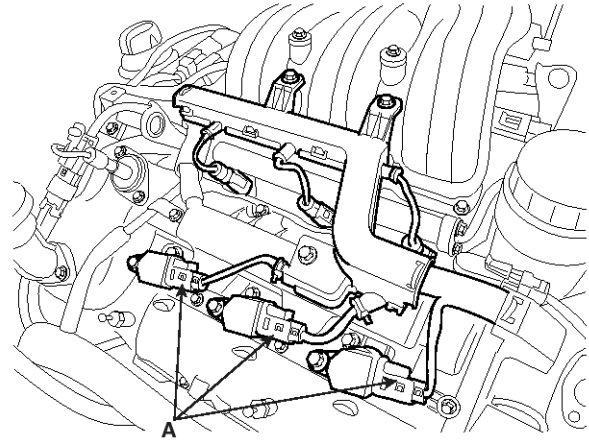

SBHEE8049D

NOTICE

When removing the ignition coil connector, pull the lock pin(A) and push the clip(B).

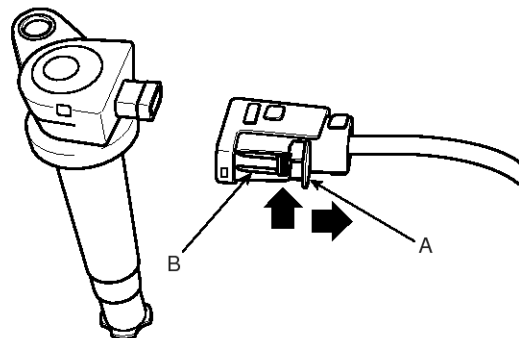

ABGE003A

2. Remove the ignition coil(A).

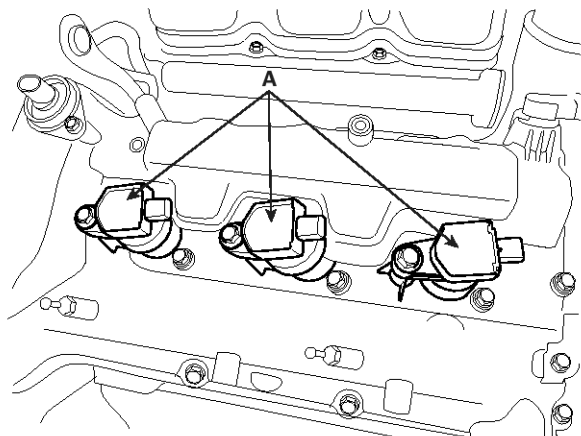

SBHEM8050D

3. Using a spark plug socket, remove the spark plug.
4. Install the spark plug to the ignition coil.
5. Ground the spark plug to the engine.

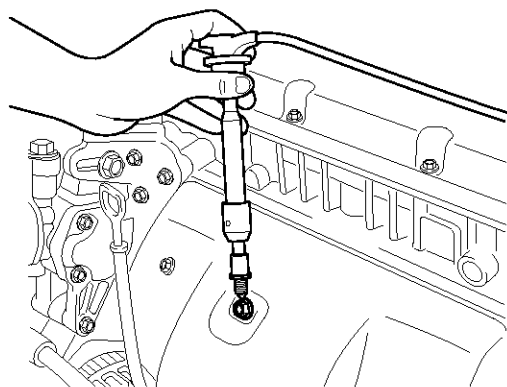

ABGE001A

6. Check if spark occurs while engine is being cranked.

NOTICE

To prevent fuel being injected from injectors while the engine is being cranked, disconnect the injector connector.

Crank the engine for no more than 5 ~ 10 seconds.

7. Inspect all the spark plugs.
8. Using a spark plug socket, install the spark plug.
9. Install the ignition coil.
10. Reconnect the ignition coil connector.

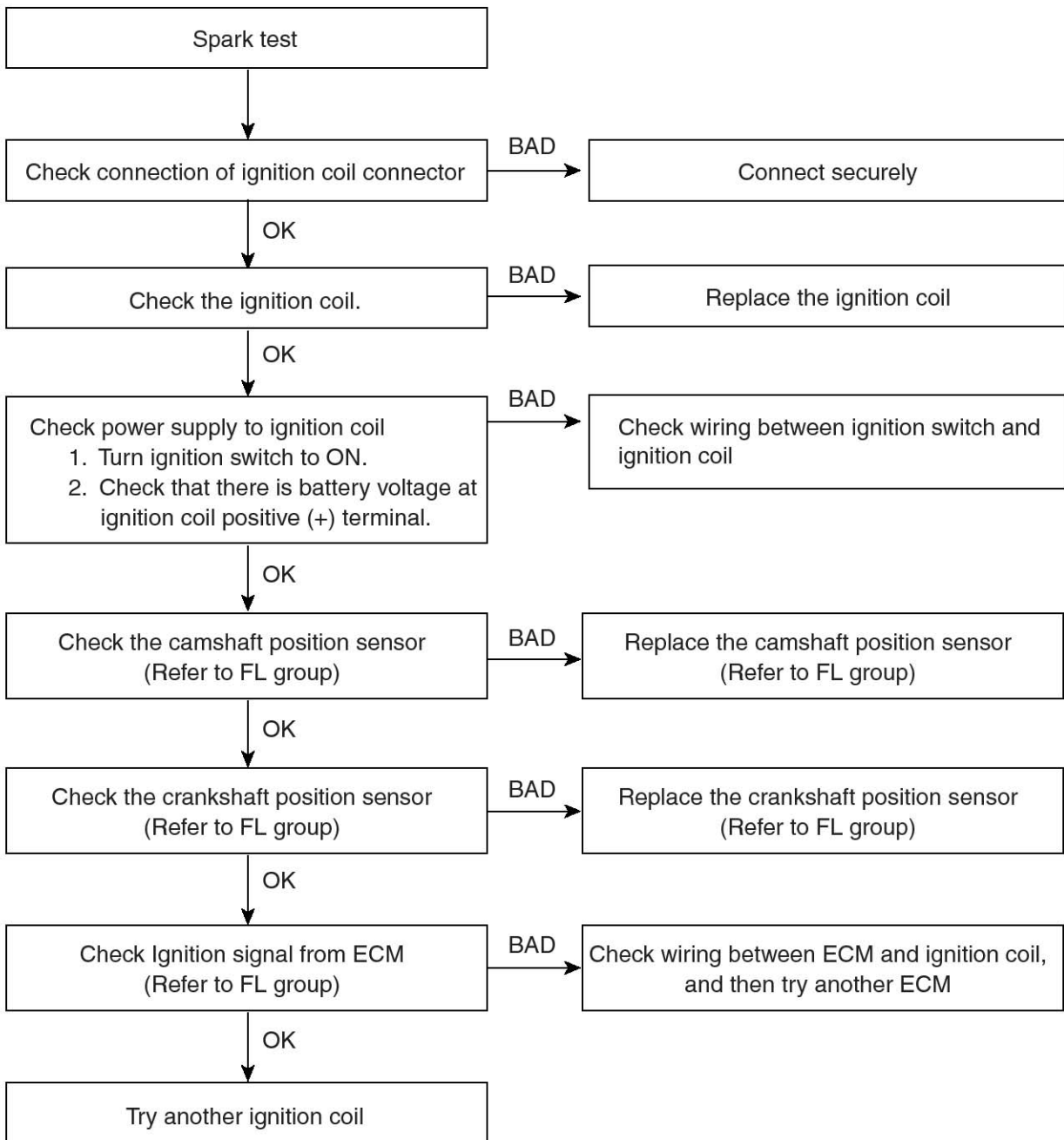

SBHEE9020L

EE-14

Engine Electrical System

Inspect Spark Plug

1. Remove the ignition coil connector(A).

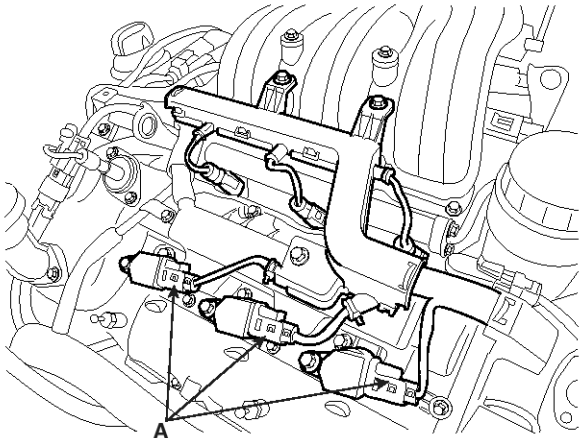

SBHEE8049D

NOTICE

When removing the ignition coil connector, pull the lock pin(A) and push the clip(B).

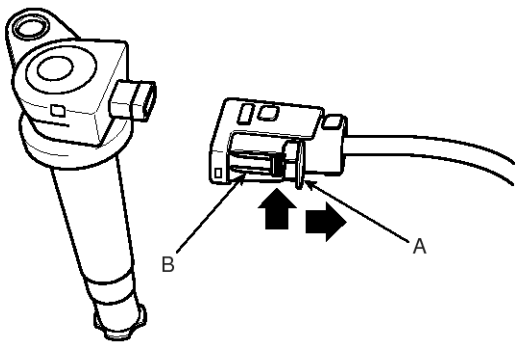

ABGE003A

2. Remove the ignition coil(A).

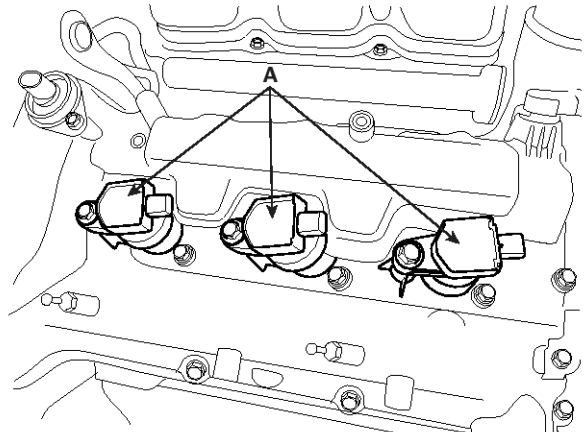

SBHEM8050D

3. Using a spark plug socket, remove the spark plug.

CAUTION

Be careful that no contaminants enter through the spark plug holes.

4. Inspect the electrodes (A) and ceramic insulator (B).

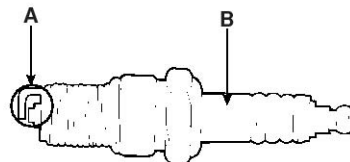

EBKD002K

Inspection Of Electrodes

Condition	Dark deposits	White deposits
Description	<ul style="list-style-type: none">- Fuel mixture too rich- Low air intake	<ul style="list-style-type: none">- Fuel mixture too lean- Advanced ignition timing- Insufficient plug tightening torque

Ignition System

5. Check the electrode gap (A).

Standard :

1.0 ~ 1.1 mm (0.0394 ~ 0.0433 in.) - Unleaded

0.8 ~ 0.9 mm (0.0315 ~ 0.0354 in.) - Leaded

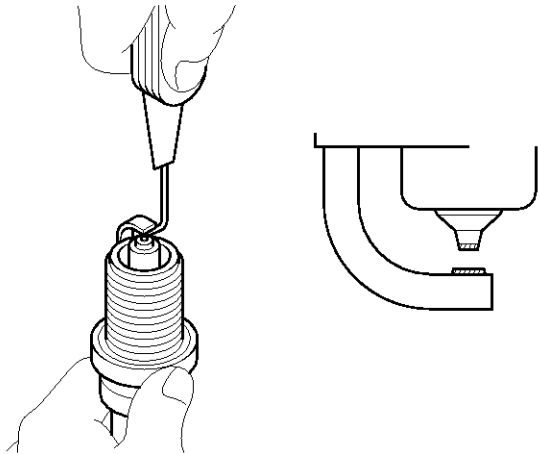

EBKE002L

Inspect Ignition Coil

1. Measure the primary coil resistance between terminals (+) and (-).

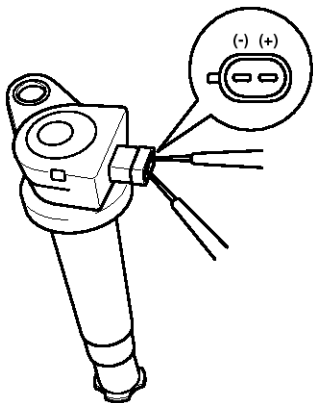

ABGE004A

Standard value: $0.62\Omega \pm 10\%$

**Replacement
Ignition Coil**

1. Remove the engine cover.
2. Disconnect the ignition coil connector(A).

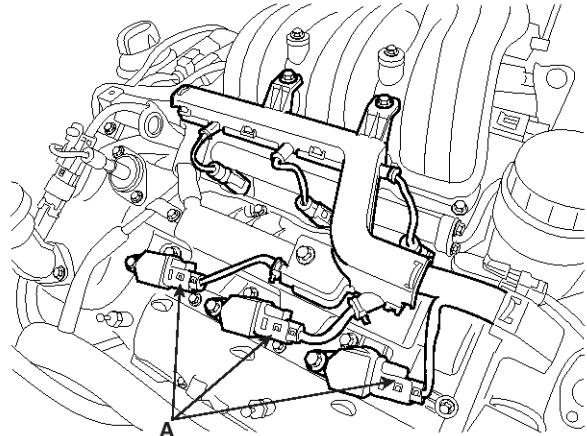

SBHEE8049D

NOTICE

When removing the ignition coil connector, pull the lock pin(A) and push the clip(B).

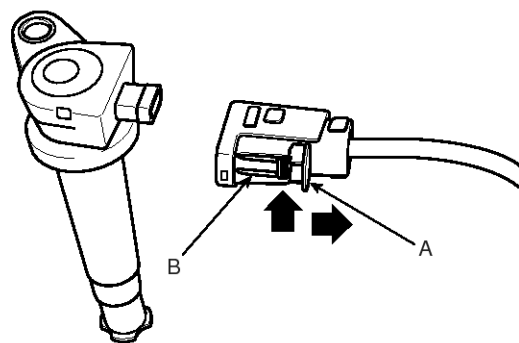

ABGE003A

EE-16

Engine Electrical System

3. Remove the ignition coil (A).

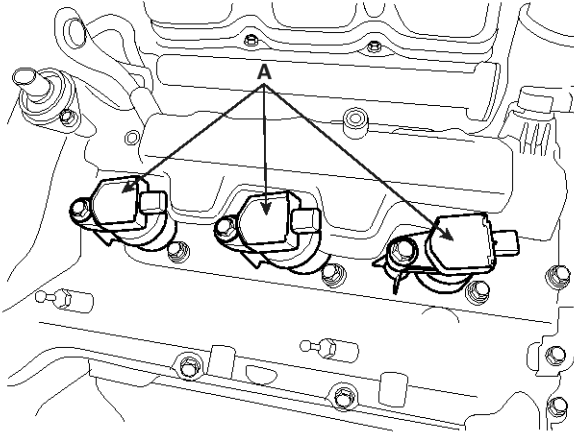

SBHEM8050D

4. Installation is the reverse of removal.

Charging System

Description

The charging system includes a battery, an alternator with a built-in regulator, and the charging indicator light and wire.

The Alternator has built-in diodes, each rectifying AC current to DC current.

Therefore, DC current appears at alternator "B" terminal.

In addition, the charging voltage of this alternator is regulated by the ECM.

The main components of the alternator are the rotor, stator, rectifier, capacitor, brushes, bearings and V-ribbed belt pulley. The brush holder contains a built-in electronic voltage regulator.

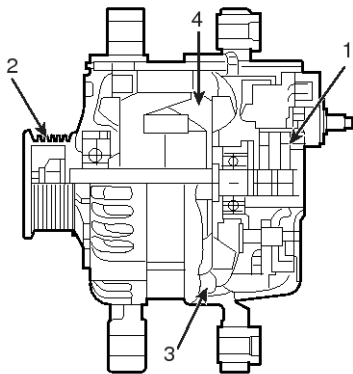

SBHEE8060D

1. Brush
2. Drive belt pulley
3. Stator
4. Rotor

On-vehicle Inspection

⚠ CAUTION

- Check that the battery cables are connected to the correct terminals.
- Disconnect the battery cables when the battery is given a quick charge.
- Never disconnect the battery while the engine is running.

Check The Battery Terminals And Fuses

1. Check that the battery terminals are not loose or corroded.
2. Check the fuses for continuity.

Inspect Drive Belt

Visually check the belt for excessive wear, frayed cords etc.

If any defect has been found, replace the drive belt.

📌 NOTICE

Cracks on the rib side of a belt are considered acceptable. If the belt has chunks missing from the ribs, it should be replaced.

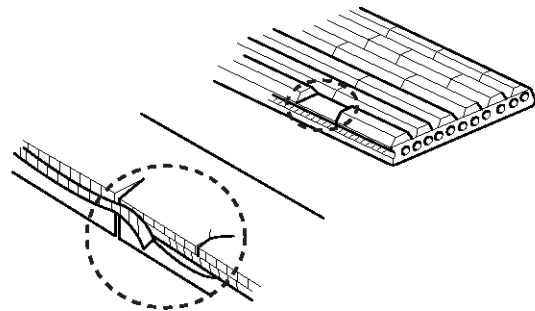

EBKD004B

Visually Check Alternator Wiring And Listen For Abnormal Noises

1. Check that the wiring is in good condition.
2. Check that there is no abnormal noise from the alternator while the engine is running.

EE-18

Engine Electrical System

Check Discharge Warning Light Circuit

1. Warm up the engine and then turn it off.
2. Turn off all accessories.
3. Turn the ignition switch "ON". Check that the discharge warning light is lit.
4. Start the engine. Check that the light is lit.

If the light does not go off as specified, troubleshoot the discharge light circuit.

Voltage Drop Test Of Alternator Output Wire

This test determines whether or not the wiring between the alternator "B" terminal and the battery (+) terminal is good by the voltage drop method.

Preparation

1. Turn the ignition switch to "OFF".
2. Disconnect the output wire from the alternator "B" terminal. Connect the (+) lead wire of ammeter to the "B" terminal of alternator and the (-) lead wire of ammeter to the output wire. Connect the (+) lead wire of voltmeter to the "B" terminal of alternator and the (-) lead wire of voltmeter to the (+) terminal of battery.

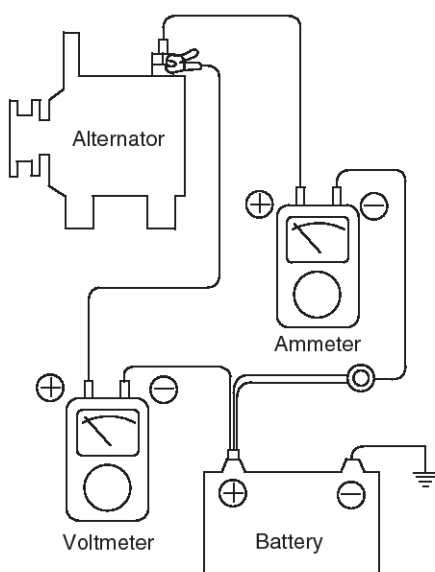

BBGE002A

Test

1. Start the engine.
2. Turn on the headlamps, blower motor, A/C and rear defrost and set the engine speed until the ammeter indicates 30A.

And then, read the voltmeter at this time.

Result

1. The voltmeter may indicate the standard value.

Standard value: 0.2V max

2. If the value of the voltmeter is higher than expected (above 0.2V max.), poor wiring is suspected. In this case check the wiring from the alternator "B" terminal to the battery (+) terminal. Check for loose connections, color change due to an over-heated harness, etc. Correct them before testing again.

3. Upon completion of the test, set the engine speed at idle.

Turn off the headlamps, blower motor and the ignition switch.

Output Current Test

This test determines whether or not the alternator gives an output current that is equivalent to the normal output.

Preparation

1. Prior to the test, check the following items and correct as necessary.

Check the battery installed in the vehicle to ensure that it is in good condition. The battery checking method is described in the section "Battery".

The battery that is used to test the output current should be one that has been partially discharged. With a fully charged battery, the test may not be conducted correctly due to an insufficient load.

Check the tension of the alternator drive belt. The belt tension check method is described in the section "Inspect drive belt".

2. Turn off the ignition switch.
3. Disconnect the battery ground cable.
4. Disconnect the alternator output wire from the alternator "B" terminal.
5. Connect a DC ammeter (0 to 150A) in series between the "B" terminal and the disconnected output wire. Be sure to connect the (-) lead wire of the ammeter to the disconnected output wire.

NOTICE

Tighten each connection securely, as a heavy current will flow. Do not rely on clips.

6. Connect a voltmeter (0 to 20V) between the "B" terminal and ground. Connect the (+) lead wire to the alternator "B" terminal and (-) lead wire to a good ground.
7. Attach an engine tachometer and connect the battery ground cable.

Charging System

8. Leave the engine hood open.

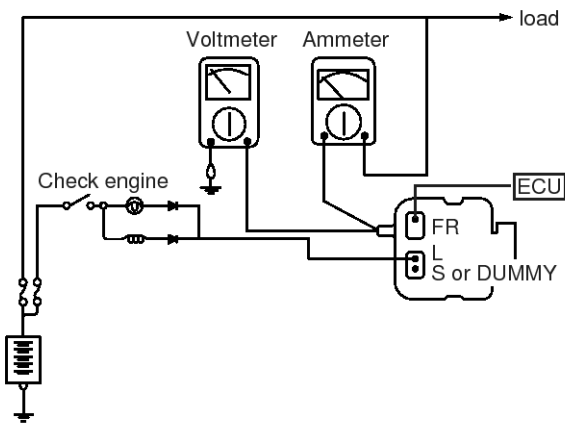

SCMEE6022N

Test

1. Check to see that the voltmeter reads as the same value as the battery voltage. If the voltmeter reads 0V, and the open circuit in the wire between alternator "B" terminal and battery (-) terminal or poor grounding is suspected.
2. Start the engine and turn on the headlamps.
3. Set the headlamps to high beam and the heater blower switch to HIGH, quickly increase the engine speed to 2,500 rpm and read the maximum output current value indicated by the ammeter.

NOTICE

After the engine start up, the charging current quickly drops.

Therefore, the above operation must be done quickly to read the maximum current value correctly.

Result

1. The ammeter reading must be higher than the limit value. If it is lower but the alternator output wire is in good condition, remove the alternator from the vehicle and test it.

Limit value : 91A min.

NOTICE

- The output current value changes with the electrical load and the temperature of the alternator itself.

Therefore, the nominal output current may not be obtained. If such is the case, keep the headlamps on the cause discharge of the battery, or use the lights of another vehicle to increase the electrical load.

The nominal output current may not be obtained if the temperature of the alternator itself or ambient temperature is too high.

In such a case, reduce the temperature before testing again.

2. Upon completion of the output current test, lower the engine speed to idle and turn off the ignition switch.
3. Disconnect the battery ground cable.
4. Remove the ammeter and voltmeter and the engine tachometer.
5. Connect the alternator output wire to the alternator "B" terminal.
6. Connect the battery ground cable.

EE-20

Engine Electrical System

Regulated Voltage Test

The purpose of this test is to check that the electronic voltage regulator controls voltage correctly.

Preparation

1. Prior to the test, check the following items and correct if necessary.
Check that the battery installed on the vehicle is fully charged. The battery checking method is described in the section "Battery".
Check the alternator drive belt tension. The belt tension check method is described in the section "Inspect drive belt".
2. Turn ignition switch to "OFF".
3. Disconnect the battery ground cable.
4. Connect a digital voltmeter between the "B" terminal of the alternator and ground. Connect the (+) lead of the voltmeter to the "B" terminal of the alternator. Connect the (-) lead to good ground or the battery (-) terminal.
5. Disconnect the alternator output wire from the alternator "B" terminal.
6. Connect a DC ammeter (0 to 150A) in series between the "B" terminal and the disconnected output wire.
Connect the (-) lead wire of the ammeter to the disconnected output wire.
7. Attach the engine tachometer and connect the battery ground cable.

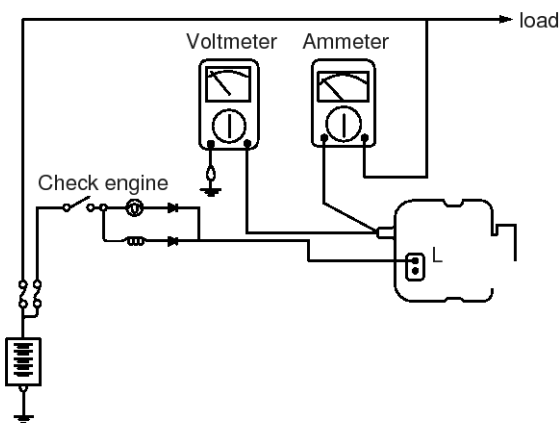

SCMEE6023N

Test

1. Turn on the ignition switch and check to see that the voltmeter indicates the following value.

Voltage: Battery voltage

If it reads 0V, there is an open circuit in the wire between the alternator "B" terminal and the battery and the battery (-) terminal.

2. Start the engine. Keep all lights and accessories off.
3. Run the engine at a speed of about 2,500 rpm and read the voltmeter when the alternator output current drops to 30A or less

Result

1. If the voltmeter reading agrees with the value listed in the regulating voltage table below, the voltage regulator is functioning correctly. If the reading is other than the standard value, the voltage regulator or the alternator is faulty.

Regulating voltage : 12.4 ~ 14.8V

2. Upon completion of the test, reduce the engine speed to idle, and turn off the ignition switch.
3. Disconnect the battery ground cable.
4. Remove the voltmeter and ammeter and the engine tachometer.
5. Connect the alternator output wire to the alternator "B" terminal.
6. Connect the battery ground cable.

Alternator

Replaement

1. Disconnect the negative cable(A) from the battery.

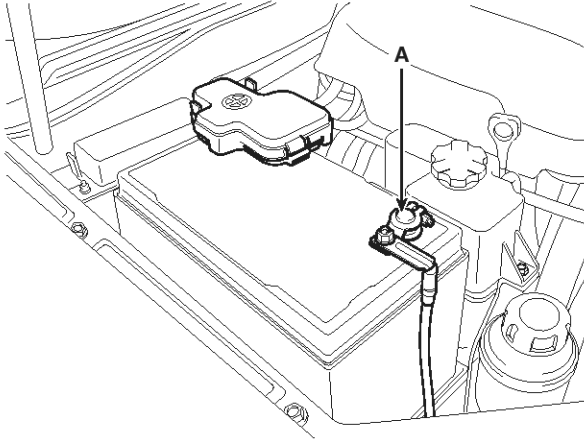

SHMM19043N

2. Remove the engine cover (A).

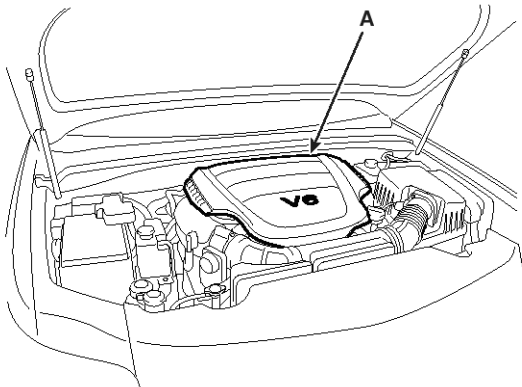

SHMEE9103L

3. Remove the radiator grill upper guard (A).

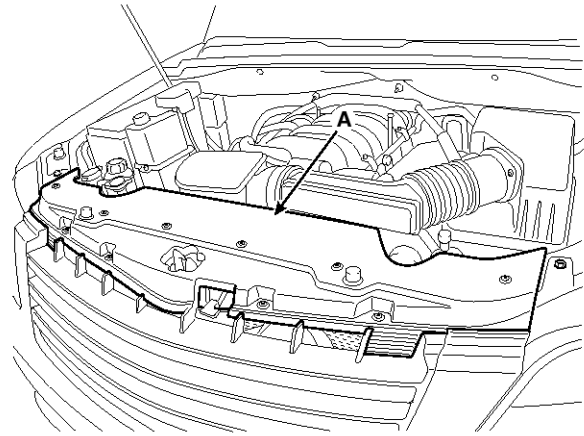

SHMM19045N

4. Disconnect the AFS connector (A) and breather hose (B) and then remove the air cleaner assembly (C).

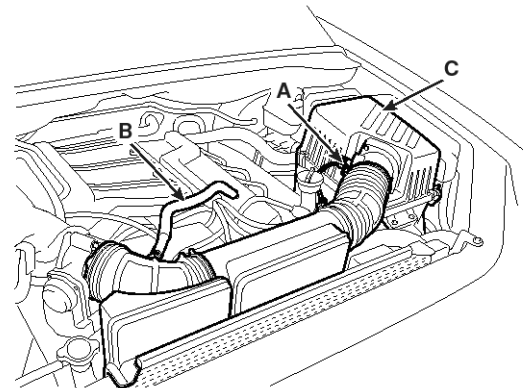

SHMEE9105L

EE-22

Engine Electrical System

5. Remove the drive belt (A).

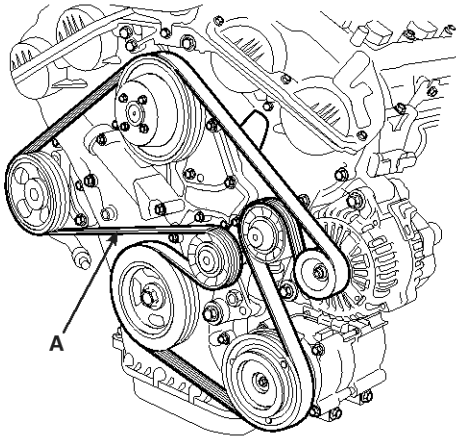

SBHEM8058D

6. Disconnect the alternator connector (A) and cable (B) from the 'B' terminal.

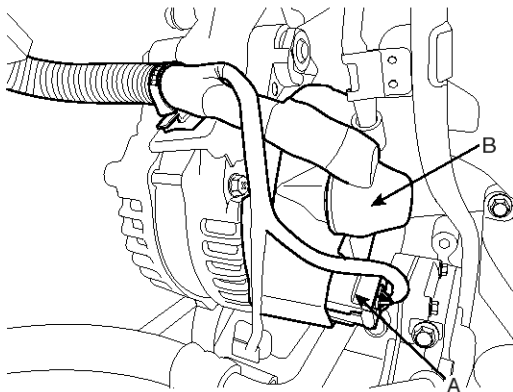

SBHEE8001D

7. Remove the alternator (A).

Tightening torque :

26.5 ~ 33.3 N.m (2.7 ~ 3.4 kgf.m, 19.5 ~ 24.6 lb-ft)

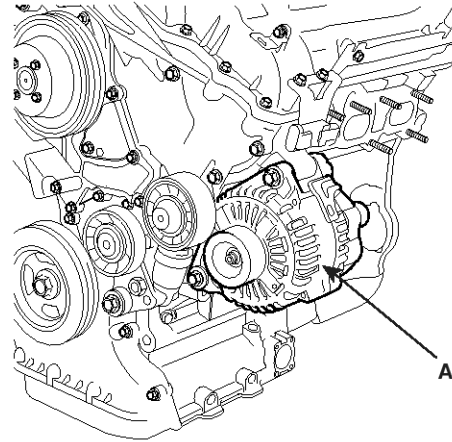

KDRF104A

8. Installation is reverse order of removal.

Battery

Description

1. The maintenance-free battery is, as the name implies, totally maintenance free and has no removable battery cell caps.
2. Water never needs to be added to the maintenance-free battery.
3. The battery is completely sealed, except for small vent holes in the cover.

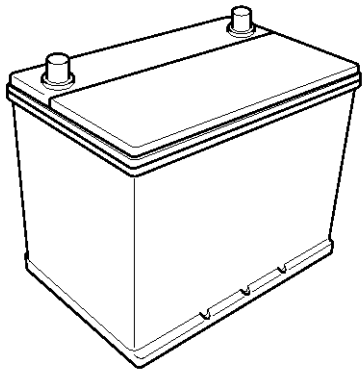

EBJD008A

Inspection

Battery Diagnostic Flow

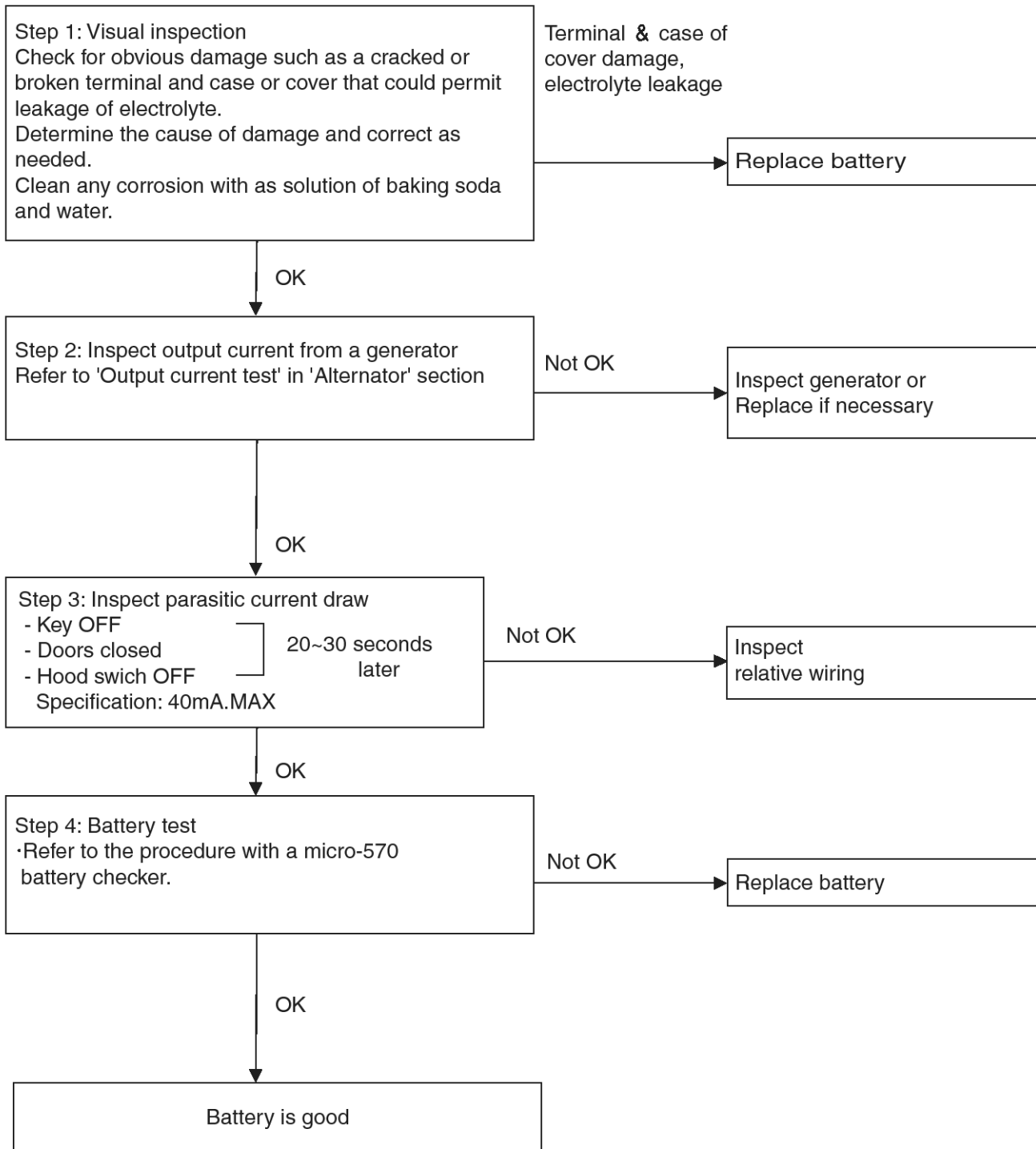

Load Test

1. Perform the following steps to complete the load test procedure for maintenance free batteries.
2. Connect the load tester clamps to the terminals and proceed with the test as follow:
 - 1) If the battery has been on charge, remove the surface charge by connecting a 300 ampere load for 15 seconds.
 - 2) Connect the voltmeter and apply the specified load.
 - 3) Read the voltage after the load has been applied for 15 seconds.
 - 4) Disconnect the load.
 - 5) Compare the voltage reading with the minimum and replace the battery if battery test voltage is below that shown in the voltage table.

Voltage	Temperature
9.6V	20°C (68.0°F) and above
9.5V	16°C (60.8°F)
9.4V	10°C (50.0°F)
9.3V	4°C (39.2°F)
9.1V	-1°C (30.2°F)
8.9V	-7°C (19.4°F)
8.7V	-12°C (10.4°F)
8.5V	-18°C (-0.4°F)

NOTICE

- If the voltage is greater than shown in the table, the battery is good.
- If the voltage is less than shown in the table, replace the battery.

Battery Diagnostic Test (2)

1. Make sure the ignition switch and all accessories are in the OFF position.
2. Disconnect the battery cables (negative first).
3. Remove the battery from the vehicle.

CAUTION

Care should be taken in the event the battery case is cracked or leaking, to protect your skin from the electrolyte.

Heavy rubber gloves (not the household type) should be worn when removing the battery.

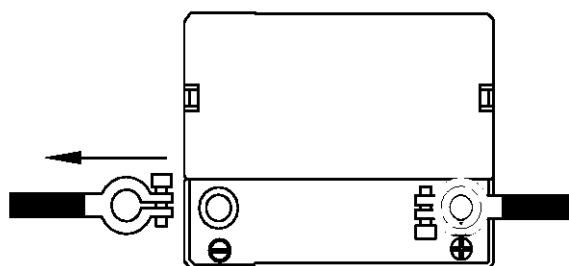

EBJD008B

4. Inspect the battery tray for damage caused by the loss of electrolyte. If acid damage is present, it will be necessary to clean the area with a solution of clean warm water and baking soda. Scrub the area with a stiff brush and wipe off with a cloth moistened with baking soda and water.
5. Clean the top of the battery with the same solution as described above.
6. Inspect the battery case and cover for cracks. If cracks are present, the battery must be replaced.
7. Clean the battery posts with a suitable battery post tool.
8. Clean the inside surface of the terminal clamps with a suitable battery cleaning tool. Replace damaged or frayed cables and broken terminal clamps.
9. Install the battery in the vehicle.
10. Connect the cable terminals to the battery post, making sure tops of the terminals are flush with the tops of the posts.
11. Tighten the terminal nuts securely.

12. Coat all connections with light mineral grease after tightening.

⚠ CAUTION

When batteries are being charged, an explosive gas forms beneath the cover of each cell. Do not smoke near batteries being charged or which have recently been charged. Do not break live circuit at the terminals of batteries being charged.

A spark will occur when the circuit is broken. Keep open flames away from battery.

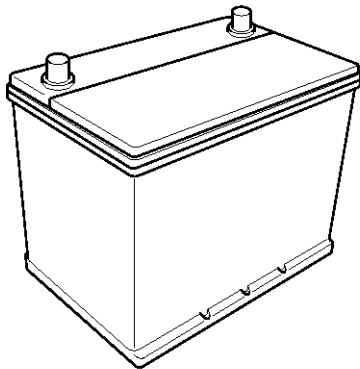

EBJD008A

Starting System

Description

The starting system includes the battery, starter, solenoid switch, ignition switch, inhibitor switch (A/T), ignition lock switch, connection wires and the battery cable.

When the ignition key is turned to the start position, current flows and energizes the starter motor's solenoid coil.

The solenoid plunger and clutch shift lever are activated, and the clutch pinion engages the ring gear.

The contacts close and the starter motor cranks. In order to prevent damage caused by excessive rotation of the starter armature when the engine starts, the clutch pinion gear overruns.

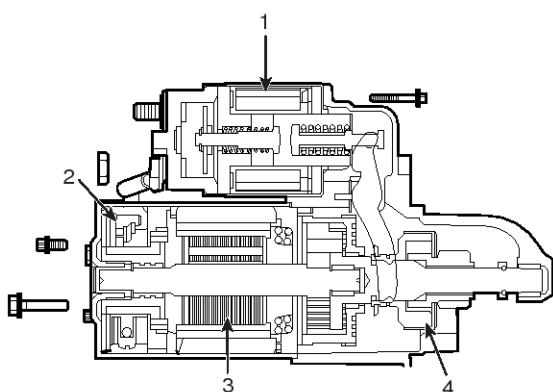

SBHEE8061D

1. Solenoid
2. Brush
3. Armature
4. Overrun clutch

Troubleshooting Starter Circuit

NOTICE

The battery must be in good condition and fully charged.

1. Disconnect the fuel pump connector
2. With the shift lever in N or P (A/T) or clutch pedal pressed (M/T), turn the ignition switch to "START"

If the starter normally cranks the engine, starting system is OK. If the starter will not crank the engine at all, go to next step.

If it won't disengage from the ring gear when you release key, check for the following until you find the cause.

- Solenoid plunger and switch malfunction.
 - Dirty pinion gear or damaged overrunning clutch.
3. Check the battery condition. Check electrical connections at the battery, battery negative cable connected to the body, engine ground cables, and the starter for looseness and corrosion. Then try starting the engine again.

If the starter cranks normally the engine, repairing the loose connection repaired the problem. The starting system is now OK.

If the starter still does not crank the engine, go to next step.

4. Disconnect the connector from the S-terminal of solenoid. Connect a jumper wire from the B-terminal of solenoid to the S-terminal of solenoid.

If the starter cranks the engine, go to next step.

If the starter still does not crank the engine, remove the starter, and repair or replace as necessary.

5. Check the following items in the order listed until you find the open circuit.
 - Check the wire and connectors between the driver's under-dash fuse/relay box and the ignition switch, and between the driver's under-dash fuse/relay box and the starter.
 - Check the ignition switch (Refer to ignition system in BE Group).
 - Check the transaxle range switch connector or ignition lock switch connector.
 - Inspect the starter relay.

EE-28

Engine Electrical System

Starter Solenoid Test

1. Disconnect the field coil wire from the M-terminal of solenoid switch.
2. Connect the battery as shown. If the starter pinion pops out, it is working properly. To avoid damaging the starter, do not leave the battery connected for more than 10 seconds.

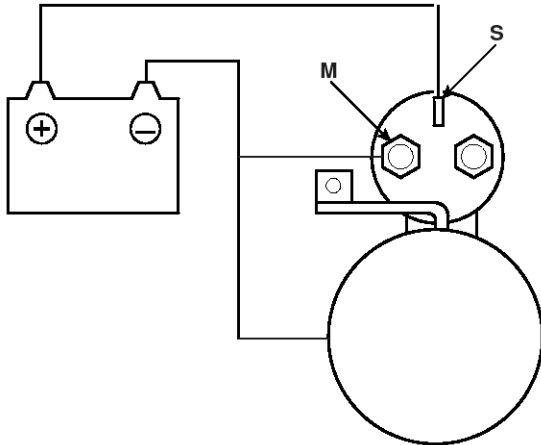

KBSE203D

3. Disconnect the battery from the M terminal.
If the pinion does not retract, the hold-in coil is working properly. To avoid damaging the starter, do not leave the battery connected for more than 10 seconds.

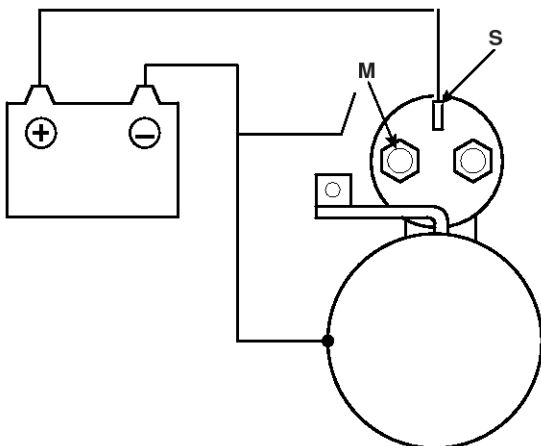

KBSE203E

4. Disconnect the battery also from the body. If the pinion retracts immediately, it is working properly. To avoid damaging the starter, do not leave the battery connected for more than 10 seconds.

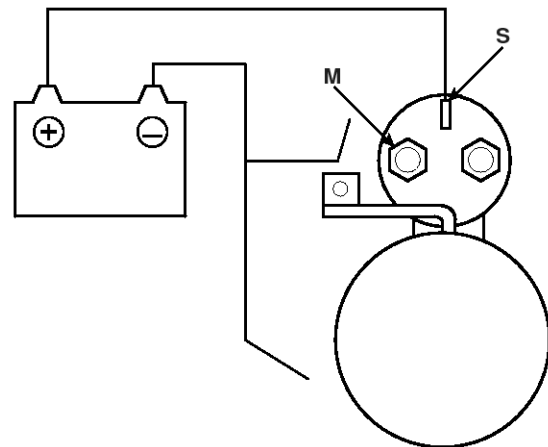

KBSE203F

Starting System

Free Running Test

1. Place the starter motor in a vise equipped with soft jaws and connect a fully-charged 12-volt battery to starter motor as follows.
2. Connect a test ammeter (100-ampere scale) and carbon pile rheostats as shown in the illustration.
3. Connect a voltmeter (15-volt scale) across starter motor.

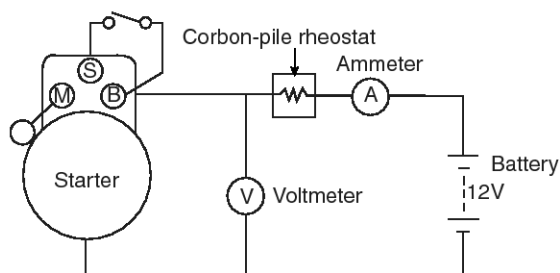

BBGE005A

4. Rotate carbon pile to the off position.
5. Connect the battery cable from battery's negative post to the starter motor body.
6. Adjust until battery voltage shown on the voltmeter reads 11volts.
7. Confirm that the maximum amperage is within the specifications and that the starter motor turns smoothly and freely.

Current : 85A MAX

Speed : 2,600 rpm MIN

EE-30

Engine Electrical System

Starter

Components

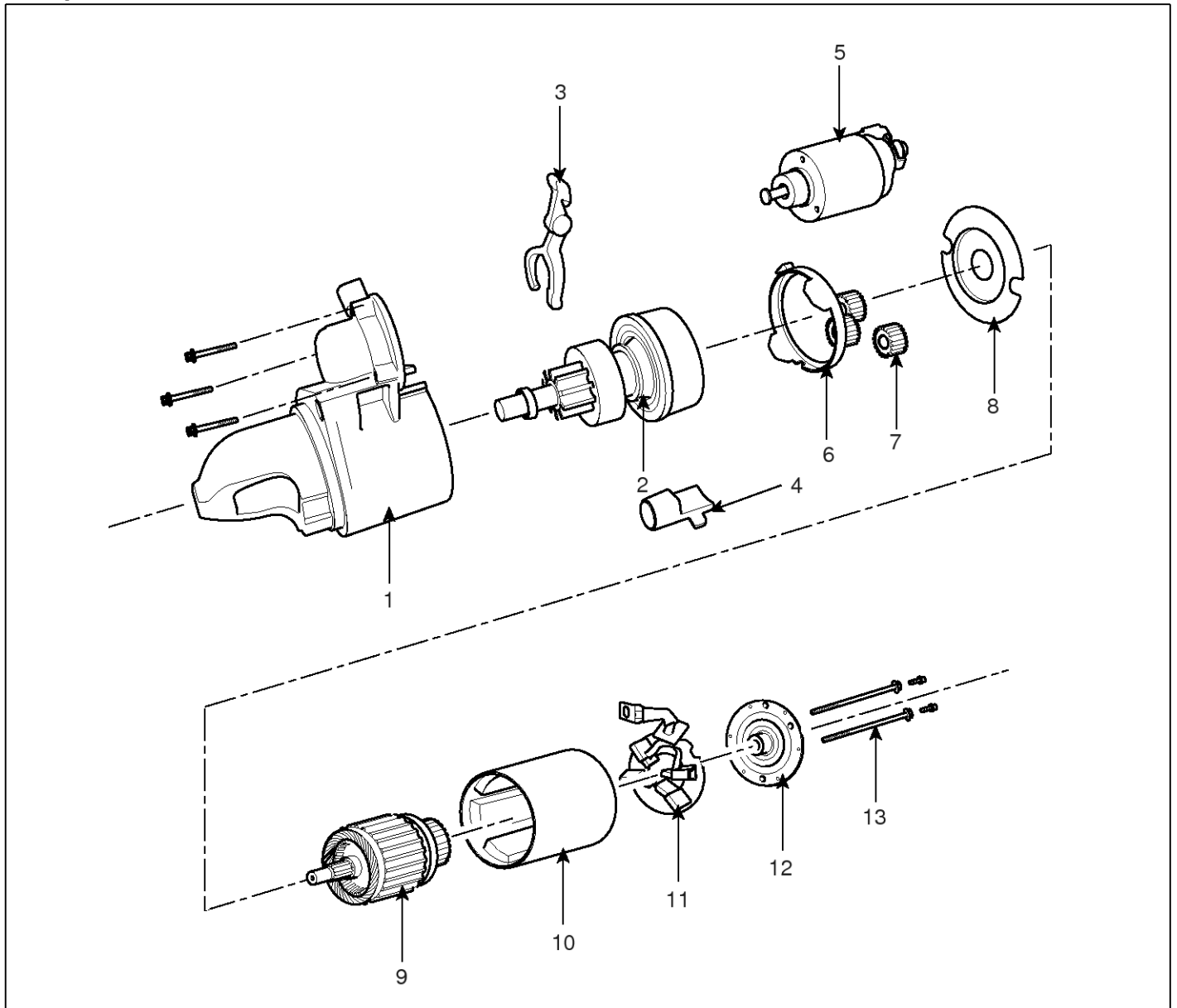

SBHEE8011D

- 1. Front bracket
- 2. Planet gear shaft assembly
- 3. Lever
- 4. Lever packing
- 5. Magnet switch
- 6. Packing
- 7. Planet gear

- 8. Shield
- 9. Armature assembly
- 10. York assembly
- 11. Brush holder assembly
- 12. Rear bracket
- 13. Through bolt

Starting System

Replaement

1. Disconnect the negative cable(A) from the battery.

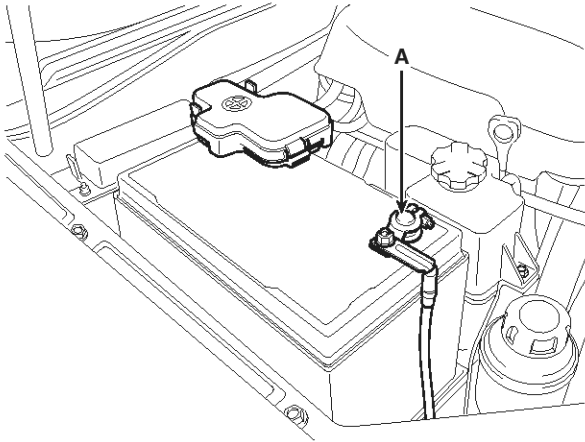

SHMM19043N

2. Remove the LH engine mounting bracket nut (A).

Tightening torque :

88.3 ~ 107.9 N.m (9.0 ~ 11.0 kgf.m, 65.1 ~ 79.6 lb-ft)

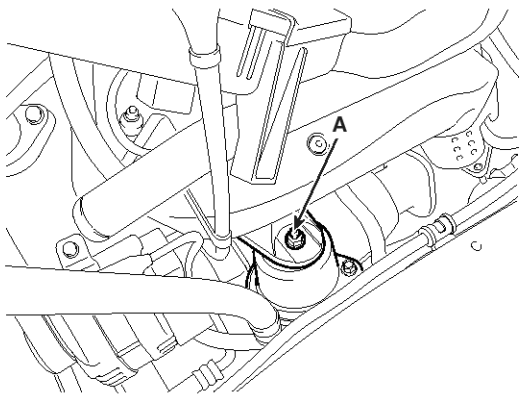

SHMEE9107L

3. Lift up the engine assembly slightly by using a jack to get access to the side of engine.
4. Remove the engine support bracket (A) and the starter protector (B).

Tightening torque :

(A) 49.0 ~ 63.7 N.m (5.0 ~ 6.5 kgf.m, 36.2 ~ 47.0 lb-ft)

(B) 0.9 ~ 1.4 N.m (8.8 ~ 13.7 kgf.m, 6.5 ~ 10.1 lb-ft)

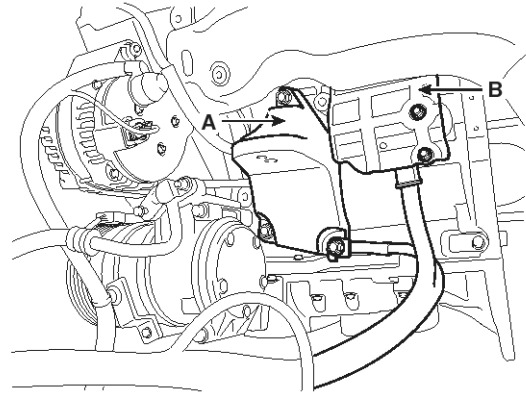

SHMEE9108L

5. Disconnect the starter cable (A) from the B terminal on the solenoid, and the connector (B) from the S terminal, and then remove the wiring protector.

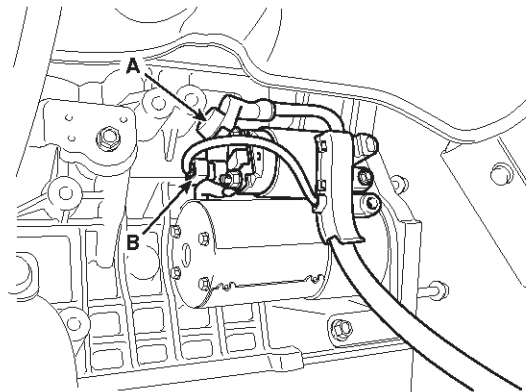

SHMEE9109L

EE-32

Engine Electrical System

6. Remove the starter (A)..

Tightening torque :

49.0 ~ 63.7 N.m (5.0 ~ 6.5 kgf.m, 36.2 ~ 47.0 lb-ft)

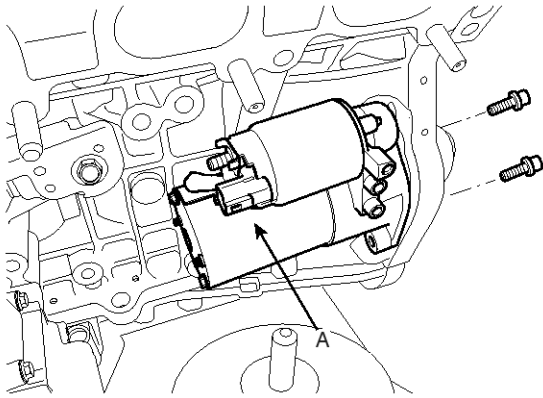

SBHEE8005D

7. Installation is reverse order of removal.

Disassembly

1. Disconnect the M-terminal on the magnet switch assembly.

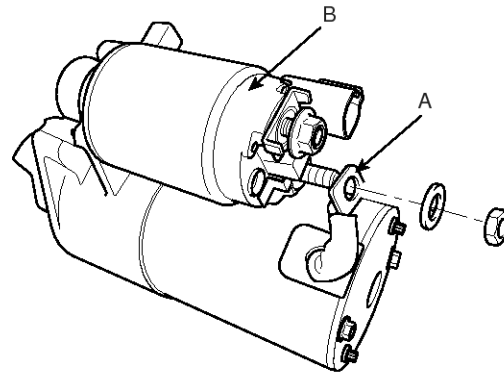

SBHEE8006D

2. After loosening the 3 screws (A), detach the magnet switch assembly (B).

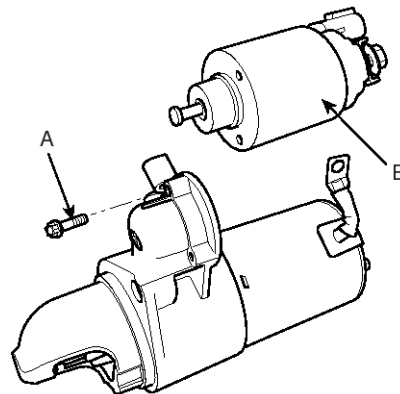

SBHEE8007D

Starting System

3. Loosen the through bolts (A).

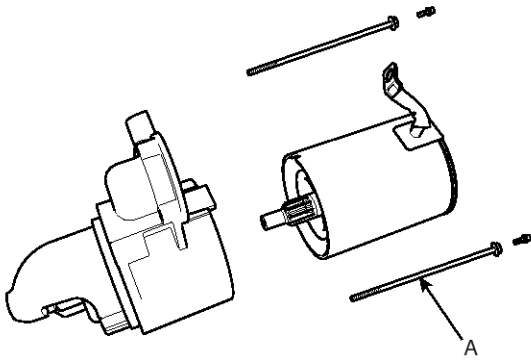

SBHEE8008D

4. Remove the brush holder assembly (A), yoke (B) and armature (C).

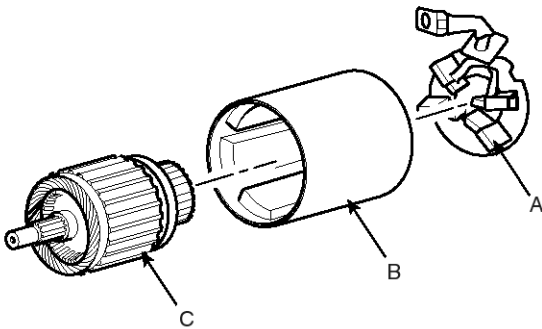

SBHEE8013D

5. Remove the shield (A) and packing (B).

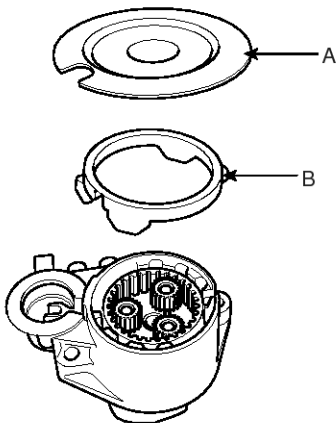

SBHEE8009D

6. Remove the lever plate (A) and lever packing (B).

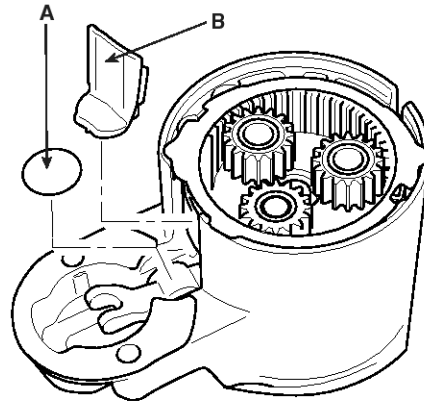

SBHEE8014D

7. Disconnect the planet gear (A).

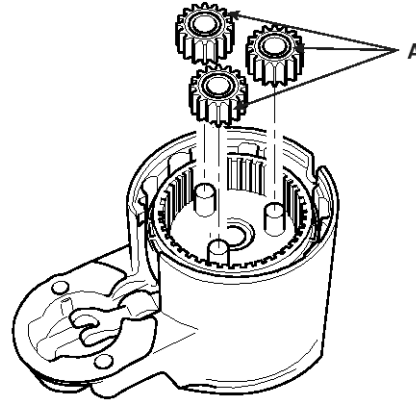

SBHEE8015D

8. Disconnect the planet shaft assembly (A) and lever (B).

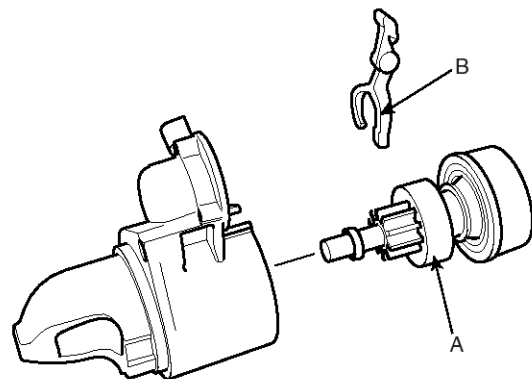

SBHEE8016D

EE-34

Engine Electrical System

9. Press the stop ring (A) using a socket (B).

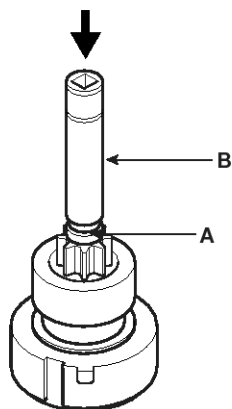

EBKD011K

10. After removing the stopper (A) using stopper pliers (B).

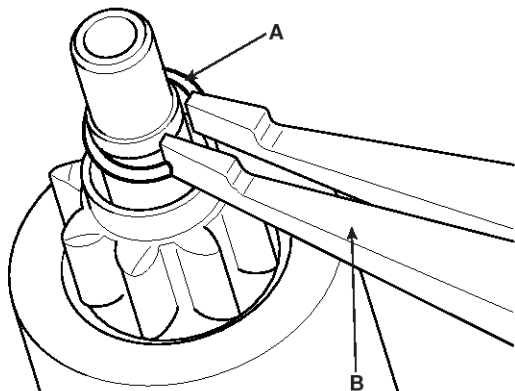

EBKD011L

11. Disconnect the stop ring (A), overrunning clutch (B), internal gear (C) and planet shaft (D).

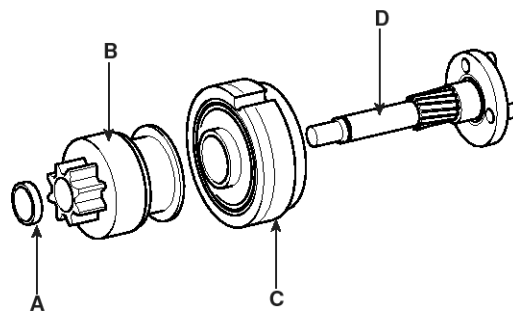

EBKD011M

12. Reassembly is the reverse of disassembly.

NOTICE

Using a suitable pulling tool (A), pull the overrunning clutch stop ring (B) over the stopper (C).

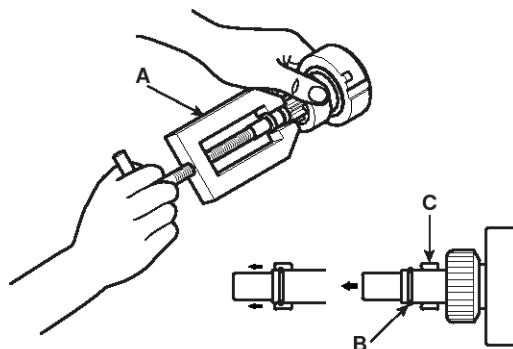

EBKD011O

Starting System

Inspection

Armature Inspection And Test

1. Remove the starter.
2. Disassemble the starter as shown at the beginning of this procedure.
3. Inspect the armature for wear or damage from contact with the permanent magnet. If there is wear or damage, replace the armature.

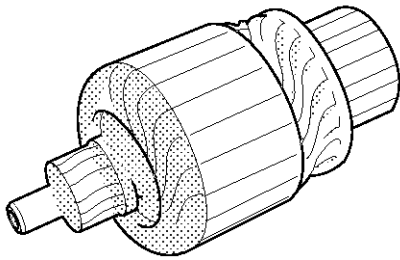

EBKD012A

4. Check the commutator (A) surface. If the surface is dirty or burnt, resurface with emery cloth or a lathe within the following specifications, or recondition with #500 or #600 sandpaper (B).

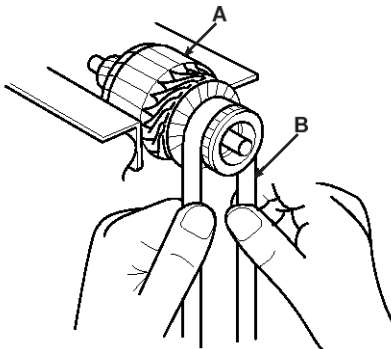

EBKD012B

5. Measure the commutator (A) runout.
 - If the commutator runout is within the service limit, check the commutator for carbon dust or brass chips between the segments.
 - If the commutator run out is not within the service limit, replace the armature.

Commutator runout

Standard (New): 0.05mm (0.0019in.) max

Service limit: 0.08mm (0.0031in.)

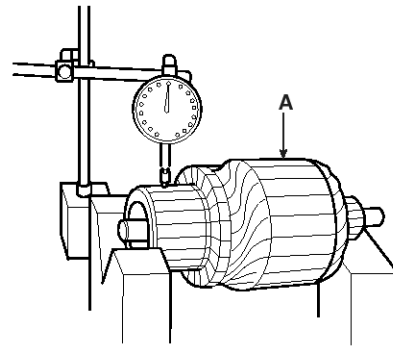

EBKD012D

6. Check the mica depth (A). If the mica is too high (B), undercut the mica with a hacksaw blade to the proper depth. Cut away all the mica (C) between the commutator segments. The undercut should not be too shallow, too narrow, or v-shaped (D).

Commutator mica depth

Standard (New) : 0.7 mm (0.0275in.)

Limit : 0.2mm (0.0079 in.)

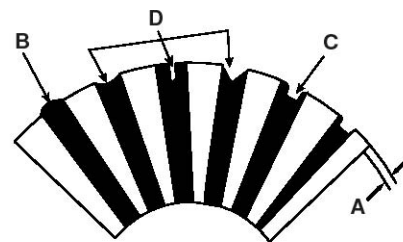

EBKD012E

EE-36

Engine Electrical System

7. Check for continuity between the segments of the commutator. If an open circuit exists between any segments, replace the armature.

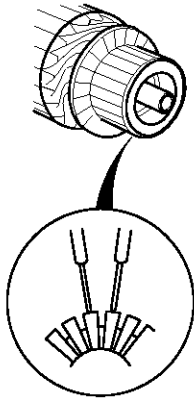

EBKD012F

8. Check with an ohmmeter that no continuity exists between the commutator (A) and armature coil core (B), and between the commutator and armature shaft (C). If continuity exists, replace the armature.

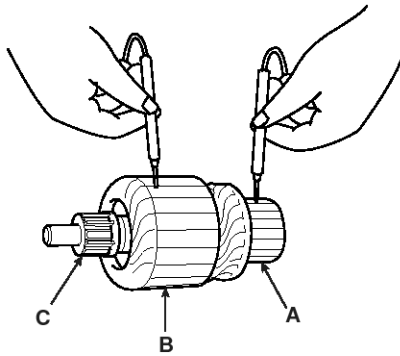

EBKD012G

Inspect Starter Brush

Brushes that are worn out, or oil-soaked, should be replaced.

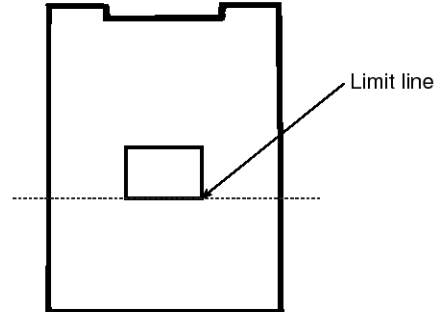

EBRF022A

Starter Brush Holder Test

1. Check that there is no continuity between the (+) brush holder (A) and (-) brush holder (B). If there is no continuity, replace the brush holder assembly.

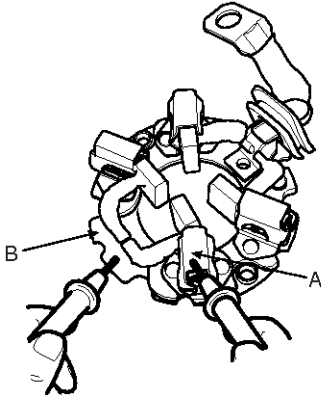

SBHEE8010D

Overrunning Clutch

1. Slide the overrunning clutch along the shaft.
Replace it if it does not slide smoothly.
2. Rotate the overrunning clutch both ways.

Does it lock in one direction and rotate smoothly in reverse? If it does not lock in either direction or it locks in both directions, replace it.

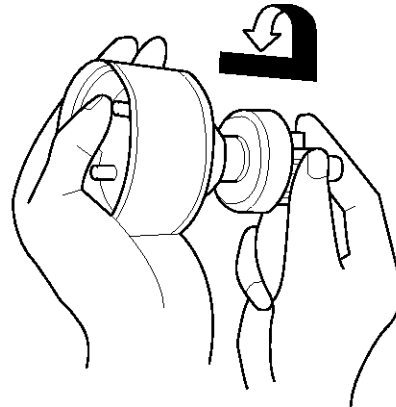

EBKD012J

3. If the starter drive gear is worn or damaged, replace the overrunning clutch assembly. (the gear is not available separately).

Check the condition of the flywheel or torque converter ring gear if the starter drive gear teeth are damaged.

Cleaning

1. Do not immerse parts in cleaning solvent. Immersing the yoke assembly and/or armature will damage the insulation. Wipe these parts with a cloth only.
2. Do not immerse the drive unit in cleaning solvent. The overrun clutch is pre-lubricated at the factory and solvent will wash lubrication from the clutch.
3. The drive unit may be cleaned with a brush moistened with cleaning solvent and wiped dry with a cloth.

Starter Relay

Inspection

1. Remove the fuse box cover.
2. Remove the starter relay.
3. Using an ohmmeter, check that there is continuity between each terminal.

Terminal	Continuity
30 - 87	NO
85 - 86	YES

4. Apply 12V to terminal 85 and ground to terminal 86.
Check for continuity between terminals 30 and 87.

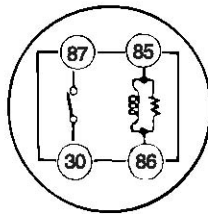
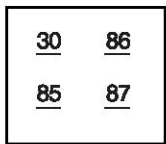

LDAD510B

5. If there is no continuity, replace the starter relay.
6. Install the starter relay.
7. Install the fuse box cover.

Cruise Control System

Cruise Control System System Block Diagram

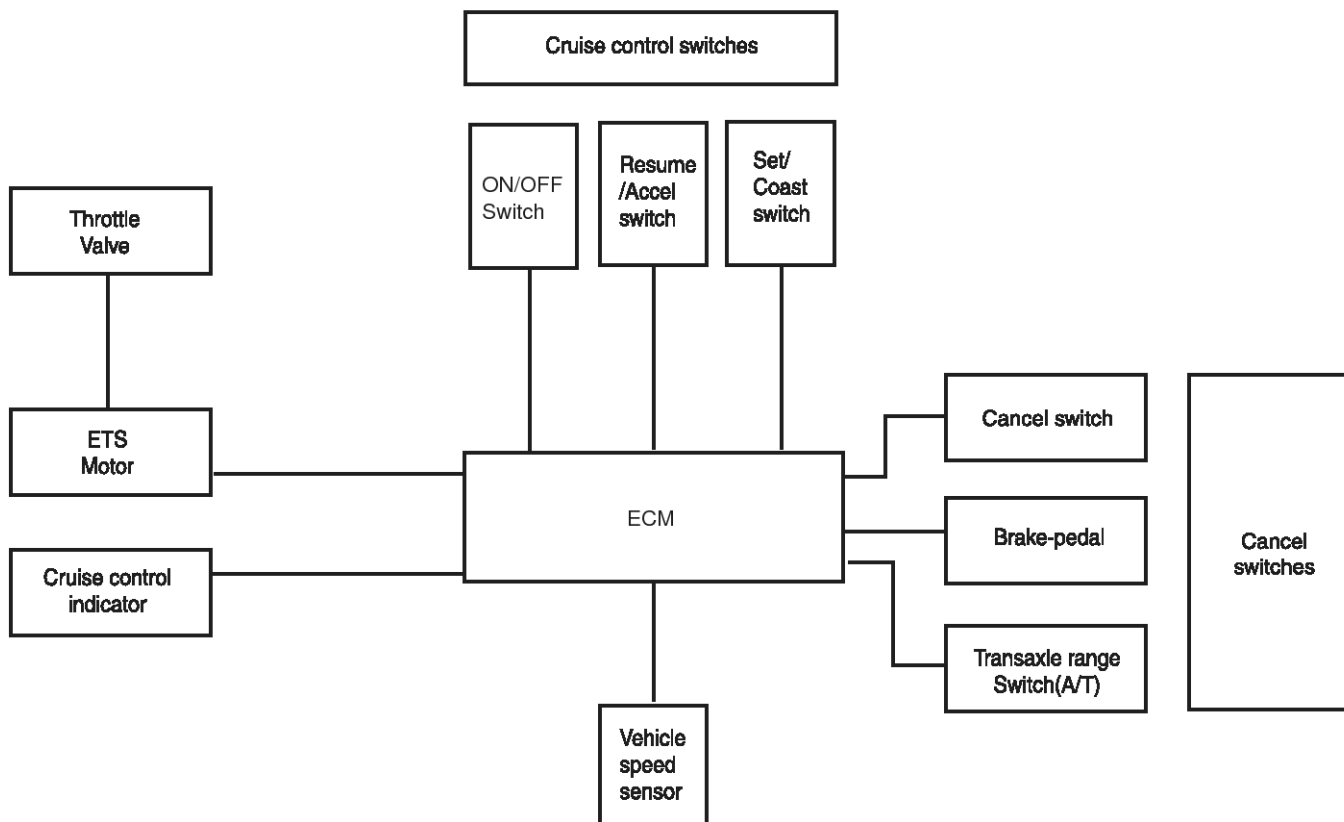

SBHEE9021L

Component Parts And Function Outline

Component part		Function
Vehicle-speed sensor		Converts vehicle speed to pulse.
ECM		Receives signals from sensor and control switches.
Cruise control indicator		Illuminate when CRUISE main switch is ON (Built into cluster)
Cruise Control switches	ON/OFF switch	Switch for automatic speed control power supply.
	Resume/Accel switch	Controls automatic speed control functions by Resume/Accel switch (Set/Coast switch)
	Set/Coast switch	
Cancel switch	Cancel switch	Sends cancel signals to ECM.
	Brake-pedal switch	
	Transaxle range switch (A/T)	
ETS motor		Regulates the throttle valve to the set opening by ECM.

* ETS : Electronic Throttle System

Cruise Control

Cruise control system is engaged by the "ON/OFF" main switch located on right of steering wheel column. The system has the capability to cruise, coast, resume speed, and accelerate, and raise "tab-up" or lower "tab-down" set speed.

It also has a safety interrupt, engaged upon depressing brake or shifting select lever.

The ECM is the control module for this system.

The main components of cruise control system are mode control switches, transaxle range switch, brake switch, vehicle speed sensor, ECM and ETS motor that connect throttle body.

The ECM contains a low speed limit which will prevent system engagement below a minimum speed of 40km/h (25mph).

The operation of the controller is controlled by mode control switches located on steering wheel.

Transaxle range switch and brake switch are provided to disengage the cruise control system. When the brake pedal is depressed or select lever shifted, the cruise control system is electrically disengaged and the throttle is returned to the idle position.

Cruise main switch

Cruise control system is engaged by pressing the "ON/OFF" push button. Releasing the "ON/OFF" push button will release throttle, clears cruise memory speed, and puts vehicle in a non-cruise mode.

Coast/Set switch

COAST/SET switch located on right of steering wheel column has two positions - "Normal" and "Depressed".
The set position - With COAST/SET switch depressed and then released the cruise speed will be set at the speed the vehicle was going when COAST/SET switch was released. The coast position - With COAST/SET switch fully depressed, driver can lower cruise speed. To decrease cruise speed, COAST/SET switch is held in, disengaging cruise control system. When vehicle has slowed to required cruise speed, releasing COAST/SET switch will re-engage system at new selected speed.

The tab down - To lower vehicle speed, cruise must be engaged and operating. Tab down is done by quickly pressing and releasing COAST/SET switch. Do not hold

COAST/SET switch in depressed position.

Tab down is a function in which vehicle speed is decrease by 1 mph (1.6km/h)

Resume/Accel switch

RES/ACCEL switch located on right of steering wheel column has two positions - "Normal" and "Depressed".

The resume position - With RES/ACCEL switch depressed and then release, this switch also returns cruise control operation to last speed (Which is temporarily disengaged by Cancel switch or Brake pedal), setting when momentarily operating RES/ACCEL switch by constant acceleration.

The accel position - With RES/ACCEL switch depressed and held in, disengaging cruise control system, when vehicle has accelerated to required cruise speed, releasing RES/ACCEL switch will re-engage speed at new selected speed.

The tab up - To increase vehicle speed, the cruise must be engaged and operating.

Tab up is done by quickly pressing and releasing RES/ACCEL switch less than 0.5 second. Do not hold RES/ACCEL switch in depressed position. Tab up is a function in which cruise speed can be increased by 1mph (1.6km/h).

Cancel switch

Cruise control system is temporarily disengaged by pressing "CANCEL" switch.

Cruise speed canceled by this switch will be recovered by RES/ACCEL switch

Cruise Control System

Trouble Symptom Charts

Trouble Symptom 1

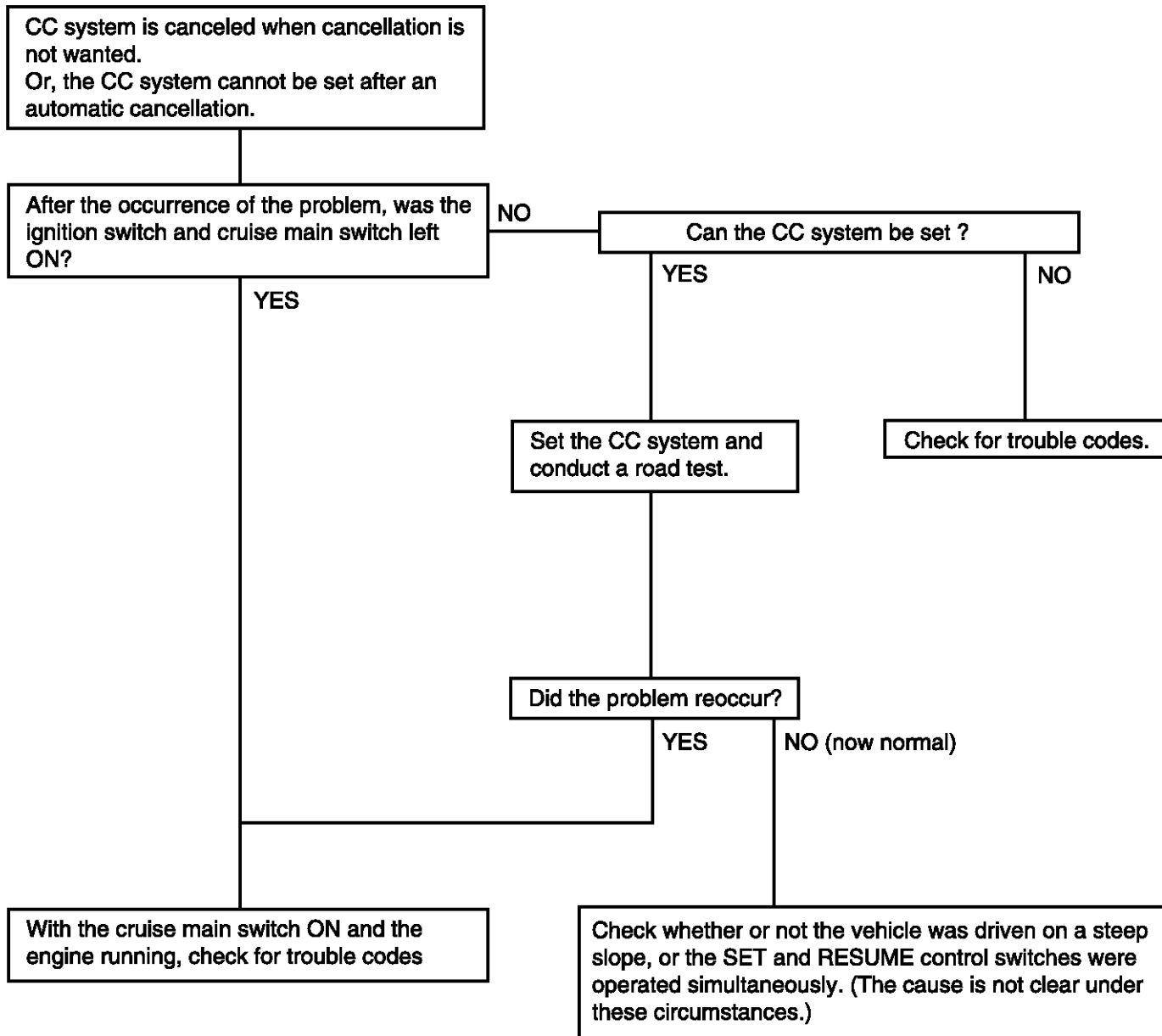

CC : Cruise Control
ECM: Engine Control Module

SCMEE6006N

EE-42

Engine Electrical System

Trouble Symptom 2

Trouble symptom	Probable cause	Remedy
The set vehicle speed varies greatly upward or downward "Surging" (repeated alternating acceleration and deceleration) occurs after setting	Malfunction of the vehicle speed sensor or circuit	Repair the vehicle speed sensor system, or replace the part
	Malfunction of ECM	Check input and output signals at ECM

Trouble Symptom 3

Trouble symptom	Probable cause	Remedy
The CC system is not canceled when the brake pedal is depressed	Damaged or disconnected wiring of the brake pedal switch	Repair the harness or replace the brake pedal switch
	Malfunction of the ECM signals	Check input and output signals at ECM

Trouble Symptom 4

Trouble symptom	Probable cause	Remedy
The CC system is not canceled when the shift lever is moved to the "N" position (It is canceled, however, when the brake pedal is depressed)	Damaged or disconnected wiring of inhibitor switch input circuit	Repair the harness or repair or replace the inhibitor switch
	Improper adjustment of inhibitor switch	
	Malfunction of the ECM signals	Check input and output signals at ECM

Trouble Symptom 5

Trouble symptom	Probable cause	Remedy
Cannot decelerate (coast) by using the SET switch	Temporary damaged or disconnected wiring of SET switch input circuit	Repair the harness or replace the SET switch
	Malfunction of the ECM signals	Check input and output signals at ECM

Trouble Symptom 6

Trouble symptom	Probable cause	Remedy
Cannot accelerate or resume speed by using the RESUME switch	Damaged or disconnected wiring, or short circuit, or RESUME switch input circuit	Repair the harness or replace the RESUME switch
	Malfunction of the ECM signals	Check input and output signals at ECM

Trouble Symptom 7

Trouble symptom	Probable cause	Remedy
CC system can be set while driving at a vehicle speed of less than 40km/h (25mph), or there is no automatic cancellation at that speed	Malfunction of the vehicle-speed sensor or circuit	Repair the vehicle speed sensor system, or replace the part
	Malfunction of the ECM signals	Check input and output signals at ECM

Cruise Control System

EE-43

Trouble Symptom 8

Trouble symptom	Probable cause	Remedy
The cruise main switch indicator lamp does not illuminate (But CC system is normal)	Damaged or disconnected bulb of cruise main switch indicator lamp	Repair the harness or replace the part.
	Harness damaged or disconnected	

Inspection Chart For Diagnostic Trouble Codes (DTC)

DTC	Description
P0564	Cruise Control Multi-Function Input A Circuit
P0565	Cruise Control ON signal
P0566	Cruise Control OFF Signal
P0567	Cruise Control RESUME Signal
P0568	Cruise Control SET Signal

Cruise Control System

EE-45

P0564 Cruise Control Multi-Function Input A Circuit

General Description

The cruise control system keeps the vehicle running at a fixed speed until a signal canceling this fixed speed is received. When the main switch is turned on with vehicle in the running mode, the battery voltage is applied to the ECM. When a signal from the control switch is input to the ECM while the vehicle is in state, the ECM controls the ETS motor to make a car go at a steady speed you want. Also, while the system is operating, "CRUISE" indicator lamp in the meter assembly lights up.

DTC Description

If the switch signal's voltage is not within the calibrated ranges when ECM checks the switch signal under detecting condition, ECM sets P0564.

DTC Detecting Condition

Item	Detecting Condition	Possible cause
DTC Strategy	<ul style="list-style-type: none">Monitors the status of the invalid input when the input voltage is converted to the switch input signals.	<ul style="list-style-type: none">Poor connectionOpen or short in cruise switch circuitFaulty cruise switchFaulty ECM
Enable Conditions	<ul style="list-style-type: none">Engine is runningIgnition voltage $\geq 9V$Cruise control system type is learned	
Threshold value	<ul style="list-style-type: none">Invalid switch signal is monitored	
Diagnosis Time	<ul style="list-style-type: none">More than 7.8 seconds failure for 9.36 seconds test	
MIL On Condition	<ul style="list-style-type: none">NO MIL ON(DTC only)	

Specification

Item	Resistance(Ω)
ON/OFF switch	$3.9\text{ k}\Omega \pm 5\%$
SET switch	$220\ \Omega \pm 5\%$
RESUME switch	$910\ \Omega \pm 5\%$
CANCEL switch	$0\ \Omega \pm 5\%$

EE-46

Engine Electrical System

Diagnostic Circuit Diagram

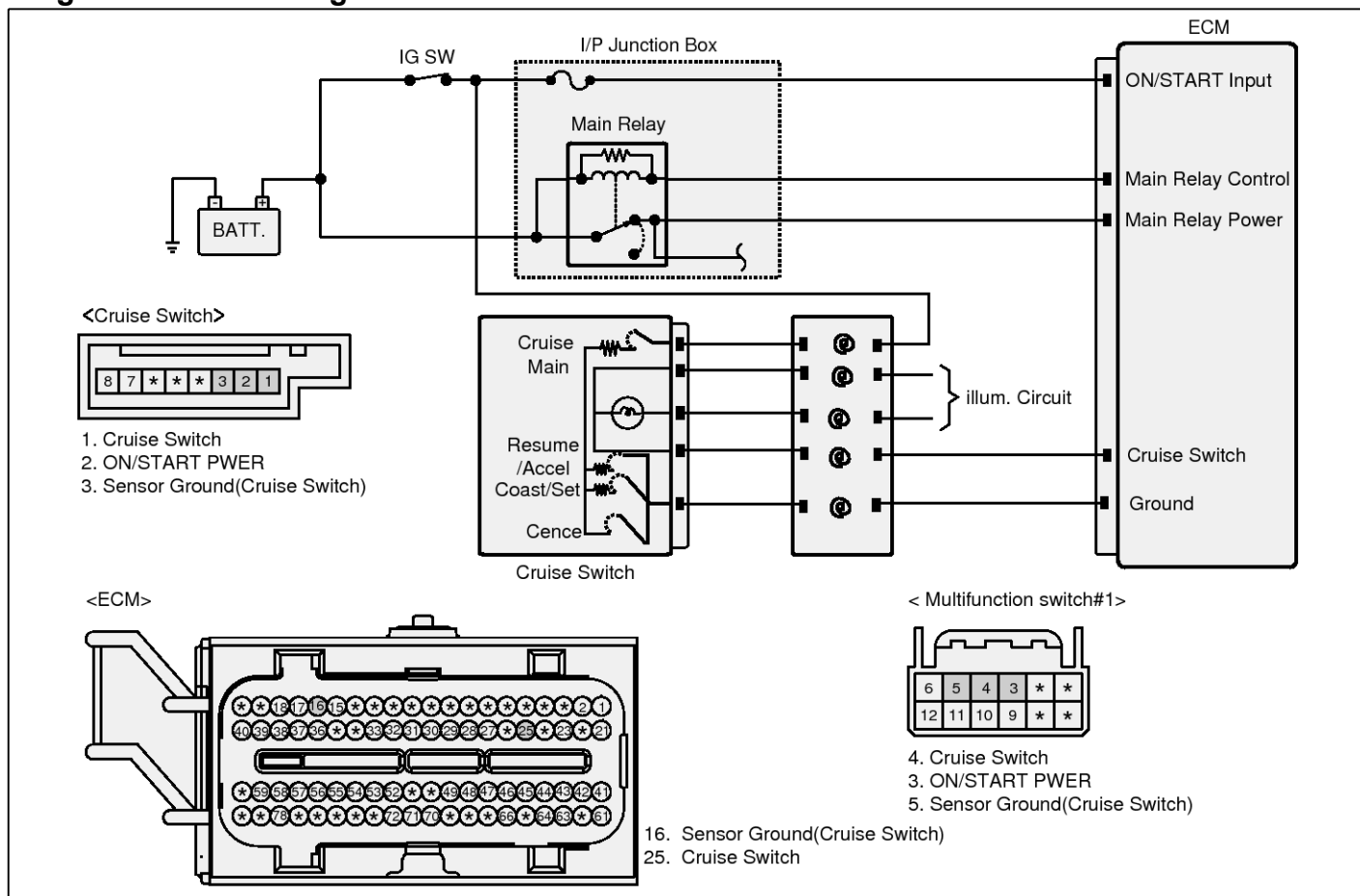

SHMFL9533L

Cruise Control System

EE-47

Monitor Scantool Data

1. Connect scantool to Data Link Connector(DLC).
2. IG "ON".

3. Select "DTC" button, and then Press "DTC Status" to check DTC's information from the DTCs menu.
4. Read "DTC Status" parameter.

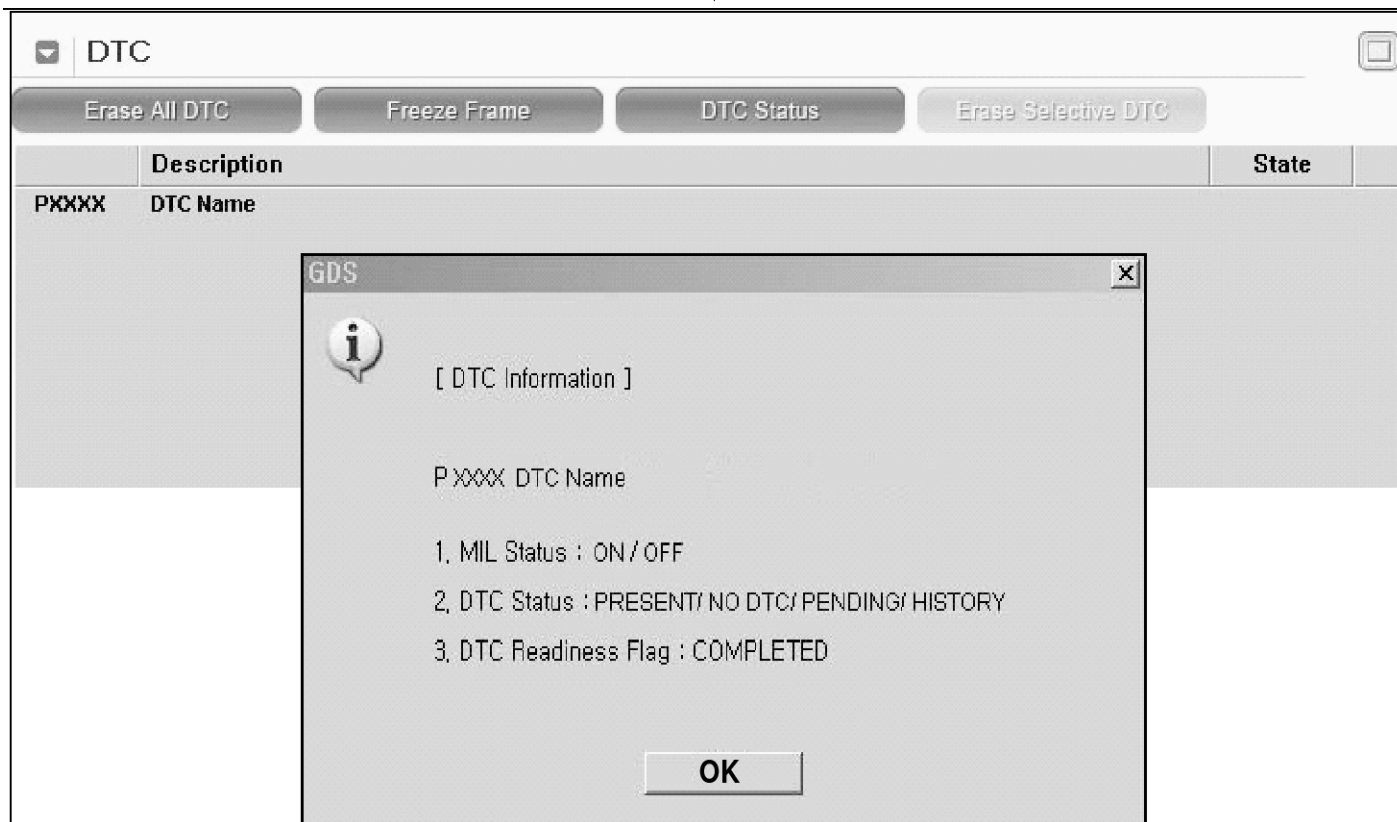

SHMFL9605L

5. Is parameter displayed "Present fault"?

YES ▶ Go to "Terminal and Connector inspection" procedure.

NO ▶ Fault is intermittent caused by poor contact in the sensor's and/or ECM's connector or was repaired and ECM memory was not cleared. Thoroughly check connectors for looseness, poor connection, ending, corrosion, contamination, deterioration, or damage. Repair or replace as necessary and go to "Verification of Vehicle Repair" procedure.

Terminal and Connector inspection

1. Many malfunctions in the electrical system are caused by poor harness and terminals. Faults can also be caused by interference from other electrical systems, and mechanical or chemical damage..
2. Thoroughly check connectors for looseness, poor connection, bending, corrosion, contamination, deterioration, or damage.
3. Has a problem been found?

YES ▶ Repair as necessary and go to "Verification of Vehicle Repair" procedure

NO ▶ Go to " Component Inspection" procedure.

EE-48

Engine Electrical System

Power Circuit Inspection

■ Check voltage

1. IG "OFF" and disconnect Cruise switch connector.
2. IG "ON"
3. Measure voltage between power terminal of Cruise switch harness connector and chassis ground.

Specification : Approx. B+

4. Is the measured voltage within specification ?

YES ▶ Go to "Signal Circuit Inspection" procedure.

NO ▶ Repair open or short to ground in harness and go to "Verification of Vehicle Repair" procedure.

Signal Circuit Inspection

■ Check voltage

1. IG "OFF" and disconnect Cruise switch connector.
2. IG "ON"
3. Measure voltage between signal terminal of Cruise switch harness connector and chassis ground.

Specification : Approx. 5V

4. Is the measured voltage within specification ?

YES ▶ Go to "Component Inspection" procedure.

NO ▶ Go to "Check short in harness" as follows.

■ Check short in harness

1. IG "OFF" and disconnect Cruise switch connector and ECM connector.
2. Measure resistance between signal and power terminals of Cruise switch harness connector.
3. Measure resistance between signal and ground terminals of Cruise switch harness connector.

Specification : Infinite

4. Is the measured resistance within specification ?

YES ▶ Go to "Check open in harness" as follows.

NO ▶ Repair short in control harness and go to "Verification of Vehicle Repair" procedure.

■ Check open in harness

1. IG "OFF" and disconnect Cruise switch connector and ECM connector.
2. Measure resistance between signal terminal of Cruise switch harness connector and cruise signal terminal of ECM harness connector.

Specification : Approx. below 1Ω

3. Is the measured resistance within specification ?

YES ▶ Go to "Component Inspection" procedure.

NO ▶ Repair open in harness, and go to "Verification of Vehicle Repair" procedure.

Component Inspection

■ Check auto cruise switch

1. IG "OFF" and disconnect Cruise switch connector.
2. Measure resistance between signal and ground terminals of Cruise switch connector with 'RESUME' switch depressed.(Component side)
3. Measure resistance between signal and ground terminals of Cruise remoon connector with each switch depressed.(Component side)

Specification :

Item	Resistance(Ω)
ON/OFF switch	3.9 kΩ ± 5%
SET switch	220 Ω ± 5%
RESUME switch	910 Ω ± 5%
CANCEL switch	0 Ω ± 5%

4. Is the measured resistance within specification ?

YES ▶ Substitute with a known - good ECM and check for proper operation. If the problem is corrected, replace ECM and go to "Verification of Vehicle Repair" procedure.

ⓘ NOTICE

There is a memory reset function on scantool that can erase optional parts automatically detected and memorized by ECM. Before or after testing ECM on the vehicle, use this function to reuse the ECM on the others

NO ▶ Substitute with a known - good auto cruise switch and check for proper operation. If the problem is corrected, replace auto cruise switch and go to "Verification of Vehicle Repair" procedure.

Verification of Vehicle Repair

After a repair, it is essential to verify that the fault has been corrected.

1. Connect scantool and select "DTC" button.
2. Press "DTC Status" button and confirm that "DTC Readiness Flag" indicates "Completed". If not, drive the vehicle within conditions noted in the freeze frame data or enable conditions.
3. Read "DTC Status" parameter.
4. Is parameter displayed "History(Not Present) fault"?

YES ▶ System performing to specification at this time. Clear the DTC.

NO ▶ Go to the applicable troubleshooting procedure.

EE-50

Engine Electrical System

P0565 Cruise Control On Signal

General Description

The cruise control system keeps the vehicle running at a fixed speed until a signal canceling this fixed speed is received. When the main switch is turned on with vehicle in the running mode, the battery voltage is applied to the ECM. When a signal from the control switch is input to the ECM while the vehicle is in state, the ECM controls the ETS motor to make a car go at a steady speed you want. Also, while the system is operating, "CRUISE" indicator lamp in the meter assembly lights up.

DTC Description

If the main switch signal is switching too frequently or stuck for too long, ECM sets P0565.

DTC Detecting Condition

Item	Detecting Condition	Possible cause
DTC Strategy	<ul style="list-style-type: none">Monitors the switch is switching too frequently or stuck for too long.	<ul style="list-style-type: none">Poor connectionFaulty cruise switchFaulty ECM
Enable Conditions	<ul style="list-style-type: none">Engine is runningIgnition voltage $\geq 9V$Cruise control system type is learned	
Threshold value	<ul style="list-style-type: none">Input switch signal is switching too frequently or stuck	
Diagnosis Time	<ul style="list-style-type: none">Switching: more than 1 second failure for 300 seconds testStuck: more than 75 seconds failure for 300 seconds test	
MIL On Condition	<ul style="list-style-type: none">NO MIL ON(DTC only)	

Specification

Item	Resistance(Ω)
ON/OFF switch	$3.9\text{ k}\Omega \pm 5\%$
SET switch	$220\ \Omega \pm 5\%$
RESUME switch	$910\ \Omega \pm 5\%$
CANCEL switch	$0\ \Omega \pm 5\%$

Cruise Control System

EE-51

Diagnostic Circuit Diagram

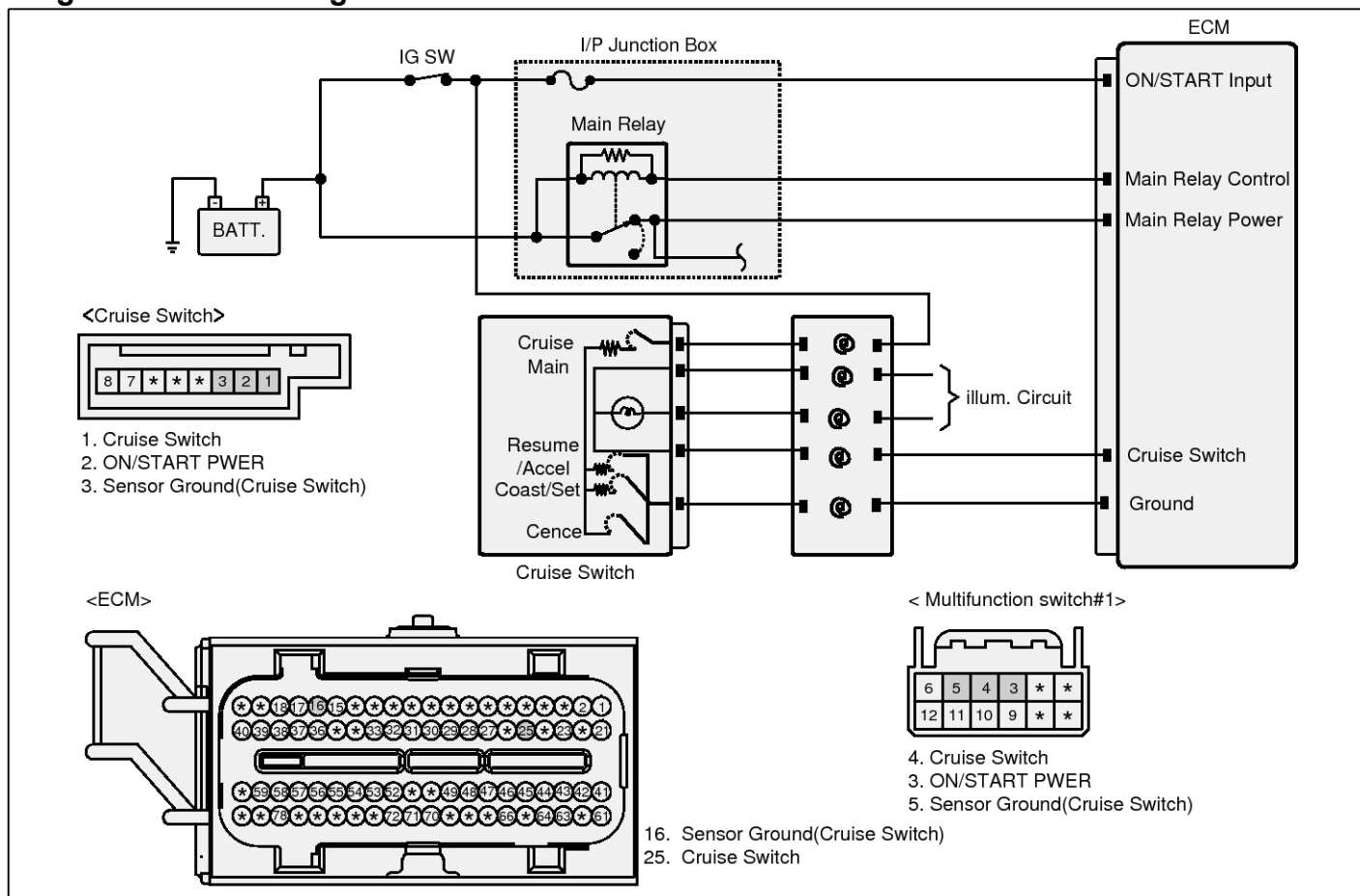

SHMFL9533L

EE-52

Engine Electrical System

Monitor Scantool Data

1. Connect scantool to Data Link Connector(DLC).
2. IG "ON".

3. Select "DTC" button, and then Press "DTC Status" to check DTC's information from the DTCs menu.
4. Read "DTC Status" parameter.

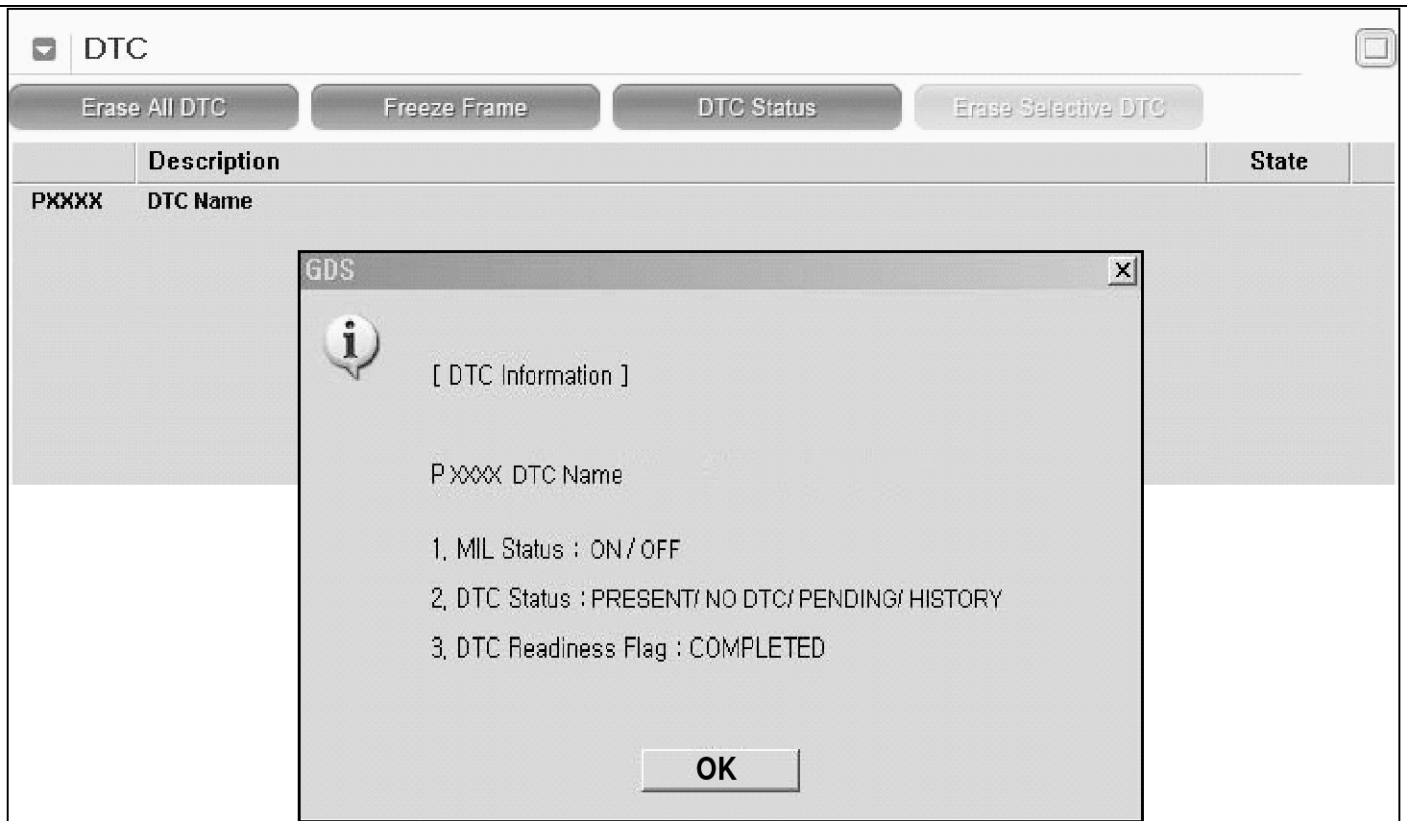

SHMFL9605L

5. Is parameter displayed "Present fault"?

YES ▶ Go to "Terminal and Connector inspection" procedure.

NO ▶ Fault is intermittent caused by poor contact in the sensor's and/or ECM's connector or was repaired and ECM memory was not cleared. Thoroughly check connectors for looseness, poor connection, ending, corrosion, contamination, deterioration, or damage. Repair or replace as necessary and go to "Verification of Vehicle Repair" procedure.

Terminal and Connector inspection

1. Many malfunctions in the electrical system are caused by poor harness and terminals. Faults can also be caused by interference from other electrical systems, and mechanical or chemical damage..
2. Thoroughly check connectors for looseness, poor connection, bending, corrosion, contamination, deterioration, or damage.
3. Has a problem been found?

YES ▶ Repair as necessary and go to "Verification of Vehicle Repair" procedure

NO ▶ Go to " Component Inspection" procedure.

Cruise Control System

Component Inspection

■ Check auto cruise switch

1. IG "OFF" and disconnect Cruise switch connector.
2. Measure resistance between signal and power terminals of Cruise switch connector with 'ON/OFF' switch depressed.(Component side)

Specification :

Item	Resistance(Ω)
ON/OFF switch	3.9 k Ω \pm 5%

3. Is the measured resistance within specification ?

YES ▶ Substitute with a known - good ECM and check for proper operation. If the problem is corrected, replace ECM and go to "Verification of Vehicle Repair" procedure.

NOTICE

There is a memory reset function on scantool that can erase optional parts automatically detected and memorized by ECM. Before or after testing ECM on the vehicle, use this function to reuse the ECM on the others

NO ▶ Substitute with a known - good auto cruise switch and check for proper operation. If the problem is corrected, replace auto cruise switch and go to "Verification of Vehicle Repair" procedure.

Verification of Vehicle Repair

After a repair, it is essential to verify that the fault has been corrected.

1. Connect scantool and select "DTC" button.
2. Press "DTC Status" button and confirm that "DTC Readiness Flag" indicates "Completed". If not, drive the vehicle within conditions noted in the freeze frame data or enable conditions.
3. Read "DTC Status" parameter.
4. Is parameter displayed "History(Not Present) fault"?

YES ▶ System performing to specification at this time. Clear the DTC.

NO ▶ Go to the applicable troubleshooting procedure.

EE-54

Engine Electrical System

P0566 Cruise Control Off Signal

General Description

The cruise control system keeps the vehicle running at a fixed speed until a signal canceling this fixed speed is received. When the main switch is turned on with vehicle in the running mode, the battery voltage is applied to the ECM. When a signal from the control switch is input to the ECM while the vehicle is in state, the ECM controls the ETS motor to make a car go at a steady speed you want. Also, while the system is operating, "CRUISE" indicator lamp in the meter assembly lights up.

DTC Description

If the cancel switch signal is switching too frequently or stuck for too long, ECM sets P0566.

DTC Detecting Condition

Item	Detecting Condition	Possible cause
DTC Strategy	<ul style="list-style-type: none">Monitors the switch is switching too frequently or stuck for too long.	<ul style="list-style-type: none">Poor connectionFaulty cruise switchFaulty ECM
Enable Conditions	<ul style="list-style-type: none">Engine is runningIgnition voltage $\geq 9V$Cruise control system type is learned	
Threshold value	<ul style="list-style-type: none">Input switch signal is switching too frequently or stuck	
Diagnosis Time	<ul style="list-style-type: none">Switching: more than 1 second failure for 300 seconds testStuck: more than 75 seconds failure for 300 seconds test	
MIL On Condition	<ul style="list-style-type: none">NO MIL ON(DTC only)	

Specification

Item	Resistance(Ω)
ON/OFF switch	$3.9\text{ k}\Omega \pm 5\%$
SET switch	$220\ \Omega \pm 5\%$
RESUME switch	$910\ \Omega \pm 5\%$
CANCEL switch	$0\ \Omega \pm 5\%$

Cruise Control System

Diagnostic Circuit Diagram

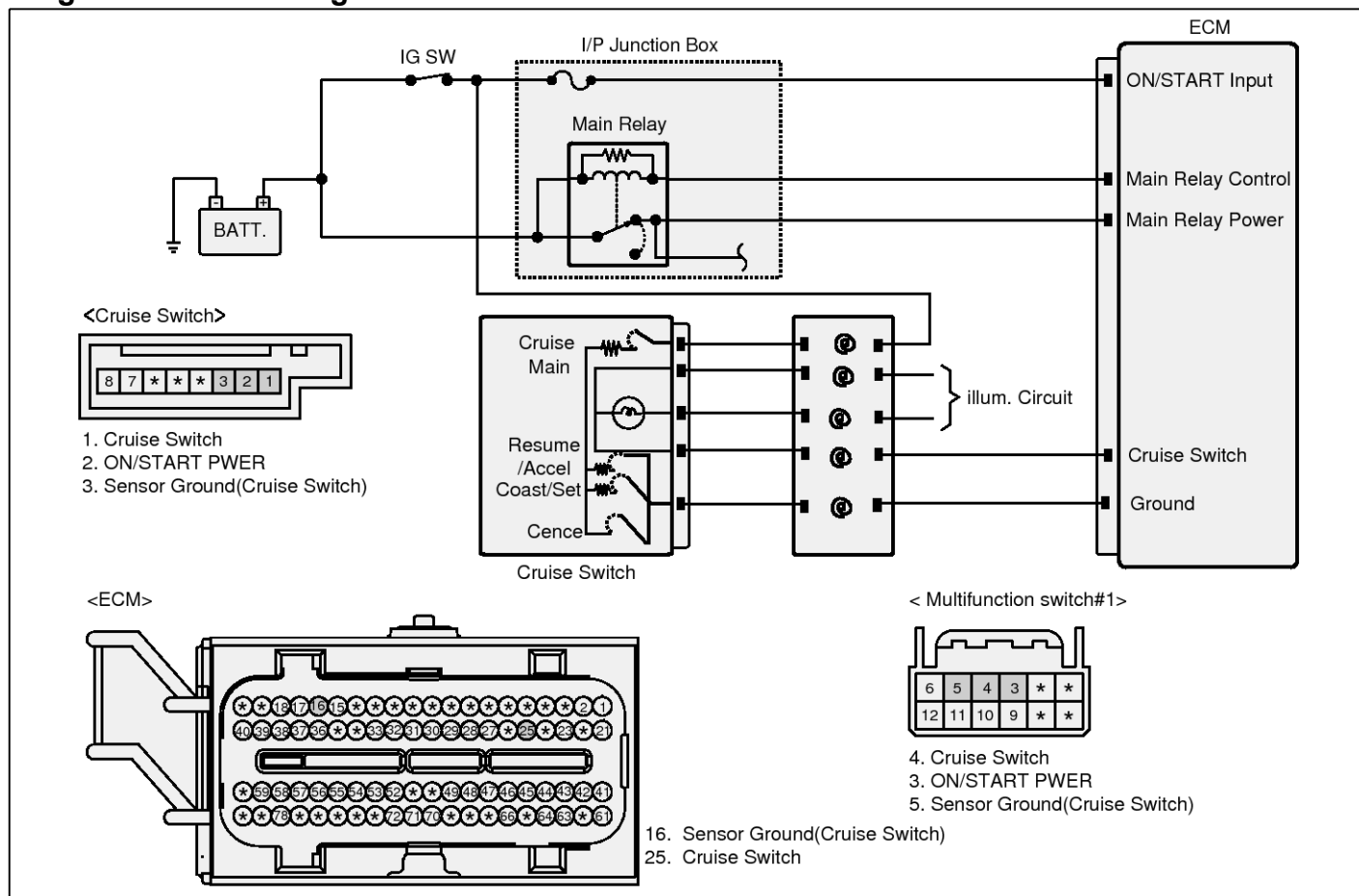

SHMFL9533L

EE-56

Engine Electrical System

Monitor Scantool Data

1. Connect scantool to Data Link Connector(DLC).
2. IG "ON".

3. Select "DTC" button, and then Press "DTC Status" to check DTC's information from the DTCs menu.
4. Read "DTC Status" parameter.

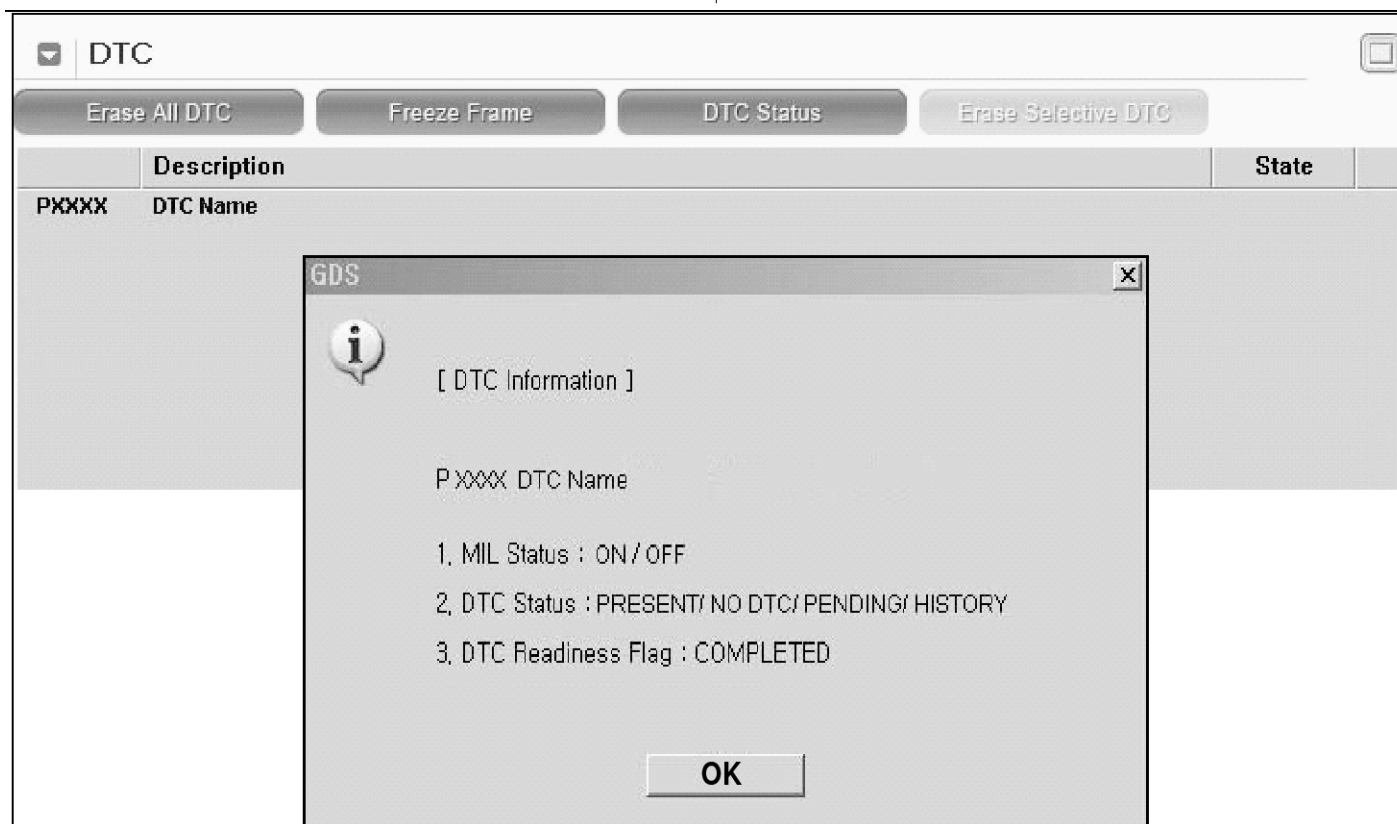

SHMFL9605L

5. Is parameter displayed "Present fault"?

YES ▶ Go to "Terminal and Connector inspection" procedure.

NO ▶ Fault is intermittent caused by poor contact in the sensor's and/or ECM's connector or was repaired and ECM memory was not cleared. Thoroughly check connectors for looseness, poor connection, ending, corrosion, contamination, deterioration, or damage. Repair or replace as necessary and go to "Verification of Vehicle Repair" procedure.

Terminal and Connector inspection

1. Many malfunctions in the electrical system are caused by poor harness and terminals. Faults can also be caused by interference from other electrical systems, and mechanical or chemical damage..
2. Thoroughly check connectors for looseness, poor connection, bending, corrosion, contamination, deterioration, or damage.
3. Has a problem been found?

YES ▶ Repair as necessary and go to "Verification of Vehicle Repair" procedure

NO ▶ Go to " Component Inspection" procedure.

Cruise Control System

Component Inspection

■ Check auto cruise switch

1. IG "OFF" and disconnect Cruise switch connector.
2. Measure resistance between signal and ground terminals of Cruise remote connector with 'CANCEL' switch depressed.(Component side)

Specification :

Item	Resistance(Ω)
CANCEL switch	$0 \Omega \pm 5\%$

3. Is the measured resistance within specification ?

YES ▶ Substitute with a known - good ECM and check for proper operation. If the problem is corrected, replace ECM and go to "Verification of Vehicle Repair" procedure.e.

NOTICE

There is a memory reset function on scantool that can erase optional parts automatically detected and memorized by ECM. Before or after testing ECM on the vehicle, use this function to reuse the ECM on the others

NO ▶ Substitute with a known - good auto cruise switch and check for proper operation. If the problem is corrected, replace auto cruise switch and go to "Verification of Vehicle Repair" procedure.

Verification of Vehicle Repair

After a repair, it is essential to verify that the fault has been corrected.

1. Connect scantool and select "DTC" button.
2. Press "DTC Status" button and confirm that "DTC Readiness Flag" indicates "Completed". If not, drive the vehicle within conditions noted in the freeze frame data or enable conditions.
3. Read "DTC Status" parameter.
4. Is parameter displayed "History(Not Present) fault"?

YES ▶ System performing to specification at this time. Clear the DTC.

NO ▶ Go to the applicable troubleshooting procedure.

EE-58

Engine Electrical System

P0567 Cruise Control Resume Signal

General Description

The cruise control system keeps the vehicle running at a fixed speed until a signal canceling this fixed speed is received. When the main switch is turned on with vehicle in the running mode, the battery voltage is applied to the ECM. When a signal from the control switch is input to the ECM while the vehicle is in state, the ECM controls the ETS motor to make a car go at a steady speed you want. Also, while the system is operating, "CRUISE" indicator lamp in the meter assembly lights up.

DTC Description

If the RESUME switch signal is switching too frequently or stuck for too long, ECM sets P0567.

DTC Detecting Condition

Item	Detecting Condition	Possible cause
DTC Strategy	<ul style="list-style-type: none">Monitors the switch is switching too frequently or stuck for too long.	<ul style="list-style-type: none">Poor connectionFaulty cruise switchFaulty ECM
Enable Conditions	<ul style="list-style-type: none">Engine is runningIgnition voltage $\geq 9V$Cruise control system type is learned	
Threshold value	<ul style="list-style-type: none">Input switch signal is switching too frequently or stuck	
Diagnosis Time	<ul style="list-style-type: none">Switching: more than 1 second failure for 300 seconds testStuck: more than 75 seconds failure for 300 seconds test	
MIL On Condition	<ul style="list-style-type: none">NO MIL ON(DTC only)	

Specification

Item	Resistance(Ω)
ON/OFF switch	$3.9\text{ k}\Omega \pm 5\%$
SET switch	$220\ \Omega \pm 5\%$
RESUME switch	$910\ \Omega \pm 5\%$
CANCEL switch	$0\ \Omega \pm 5\%$

Cruise Control System

Diagnostic Circuit Diagram

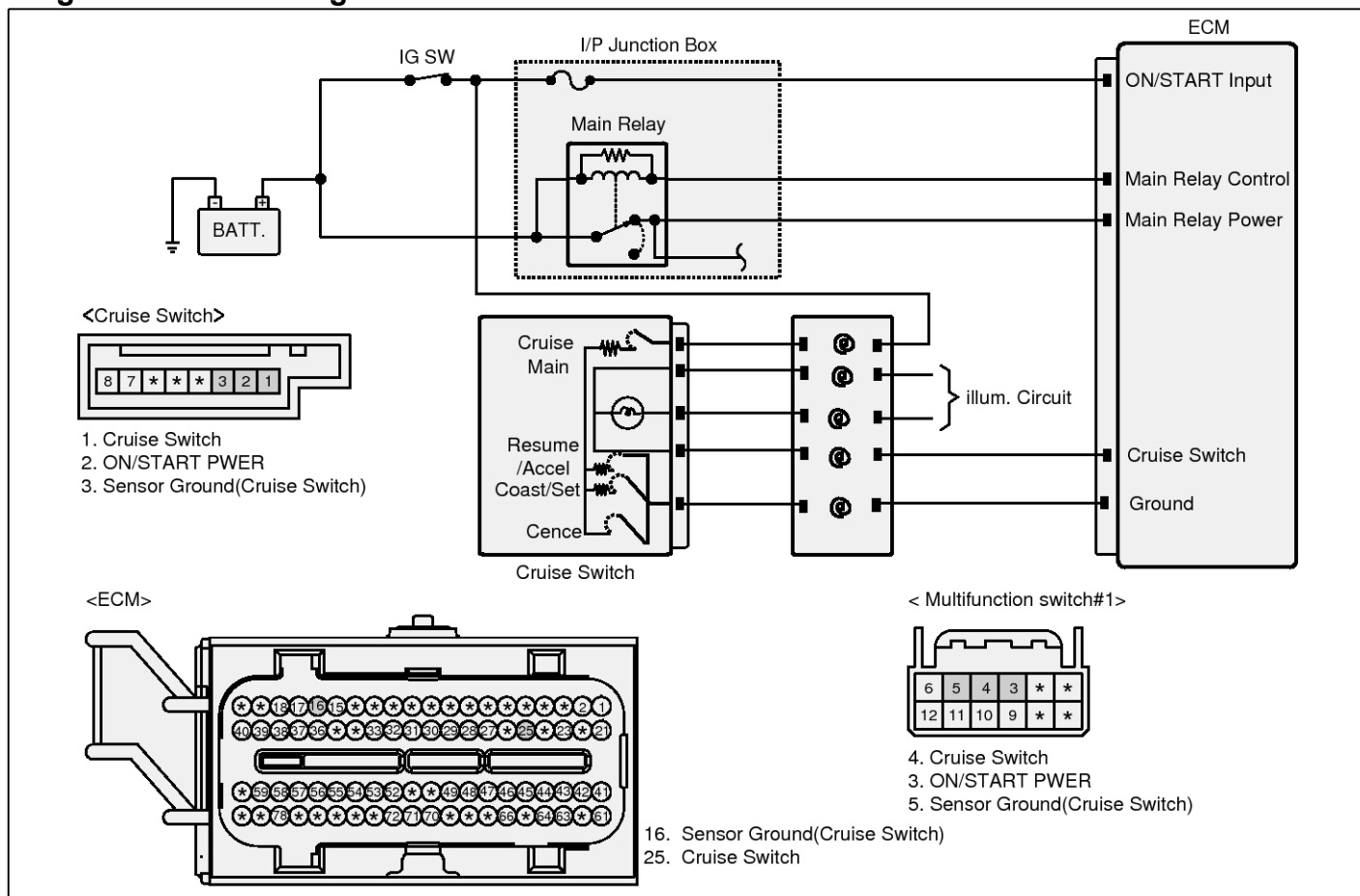

SHMFL9533L

EE-60

Engine Electrical System

Monitor Scantool Data

1. Connect scantool to Data Link Connector(DLC).
2. IG "ON".

3. Select "DTC" button, and then Press "DTC Status" to check DTC's information from the DTCs menu.
4. Read "DTC Status" parameter.

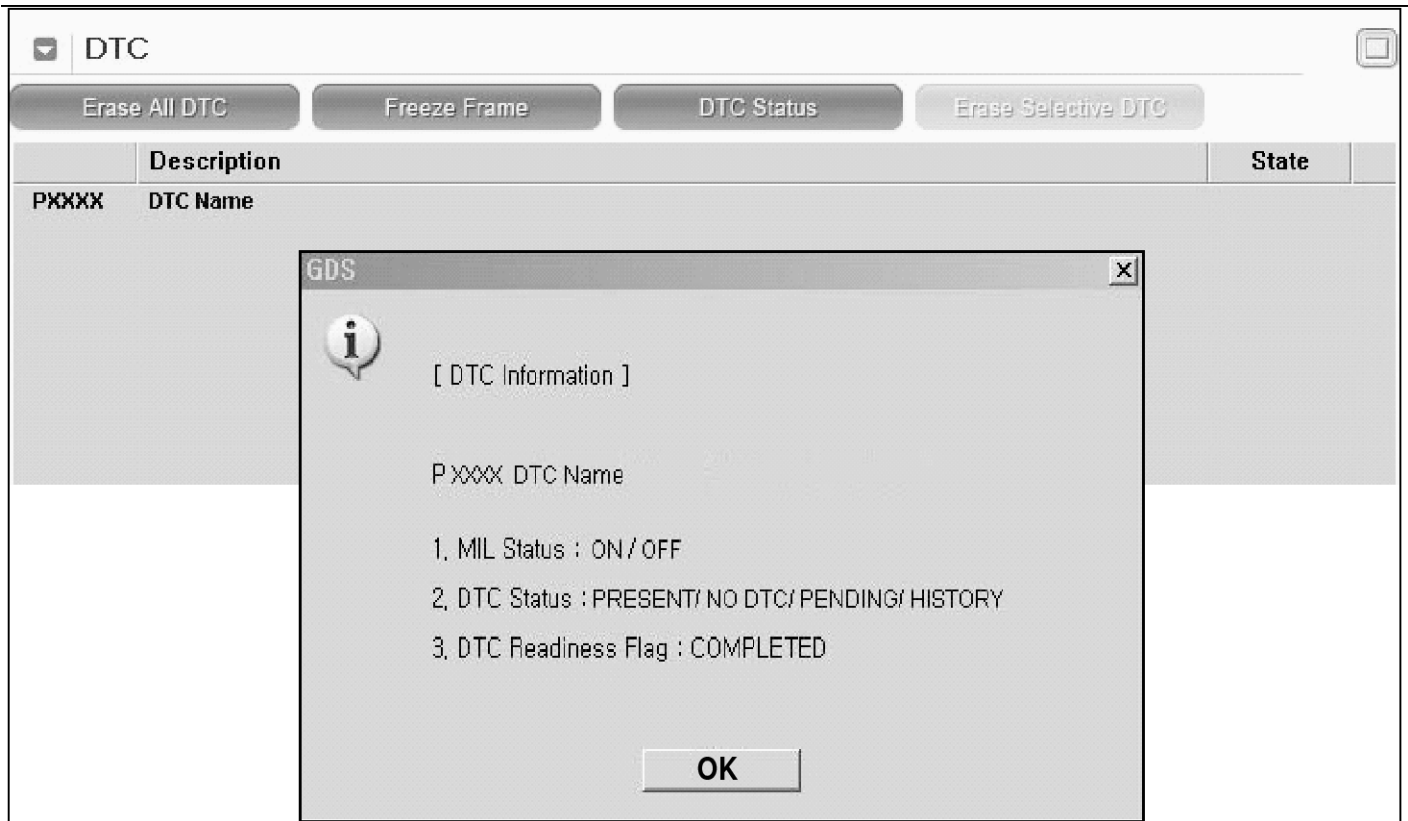

SHMFL9605L

5. Is parameter displayed "Present fault"?

YES ▶ Go to "Terminal and Connector inspection" procedure.

NO ▶ Fault is intermittent caused by poor contact in the sensor's and/or ECM's connector or was repaired and ECM memory was not cleared. Thoroughly check connectors for looseness, poor connection, ending, corrosion, contamination, deterioration, or damage. Repair or replace as necessary and go to "Verification of Vehicle Repair" procedure.

Terminal and Connector inspection

1. Many malfunctions in the electrical system are caused by poor harness and terminals. Faults can also be caused by interference from other electrical systems, and mechanical or chemical damage..
2. Thoroughly check connectors for looseness, poor connection, bending, corrosion, contamination, deterioration, or damage.
3. Has a problem been found?

YES ▶ Repair as necessary and go to "Verification of Vehicle Repair" procedure

NO ▶ Go to " Component Inspection" procedure.

Cruise Control System

Component Inspection

■ Check auto cruise switch

1. IG "OFF" and disconnect Cruise switch connector.
2. Measure resistance between signal and ground terminals of Cruise switch connector with 'RESUME' switch depressed.(Component side)

Specification :

Item	Resistance(Ω)
RESUME switch	910 $\Omega \pm 5\%$

3. Is the measured resistance within specification ?

YES ▶ Substitute with a known - good ECM and check for proper operation. If the problem is corrected, replace ECM and go to "Verification of Vehicle Repair" procedure.

NOTICE

There is a memory reset function on scantool that can erase optional parts automatically detected and memorized by ECM. Before or after testing ECM on the vehicle, use this function to reuse the ECM on the others

NO ▶ Substitute with a known - good auto cruise switch and check for proper operation. If the problem is corrected, replace auto cruise switch and go to "Verification of Vehicle Repair" procedure.

Verification of Vehicle Repair

After a repair, it is essential to verify that the fault has been corrected.

1. Connect scantool and select "DTC" button.
2. Press "DTC Status" button and confirm that "DTC Readiness Flag" indicates "Completed". If not, drive the vehicle within conditions noted in the freeze frame data or enable conditions.
3. Read "DTC Status" parameter.
4. Is parameter displayed "History(Not Present) fault"?

YES ▶ System performing to specification at this time. Clear the DTC.

NO ▶ Go to the applicable troubleshooting procedure.

EE-62

Engine Electrical System

P0568 Cruise Control Set Signal

General Description

The cruise control system keeps the vehicle running at a fixed speed until a signal canceling this fixed speed is received. When the main switch is turned on with vehicle in the running mode, the battery voltage is applied to the ECM. When a signal from the control switch is input to the ECM while the vehicle is in state, the ECM controls the ETS motor to make a car go at a steady speed you want. Also, while the system is operating, "CRUISE" indicator lamp in the meter assembly lights up.

DTC Description

If the SET switch signal is switching too frequently or stuck for too long, ECM sets P0568.

DTC Detecting Condition

Item	Detecting Condition	Possible cause
DTC Strategy	<ul style="list-style-type: none">Monitors the switch is switching too frequently or stuck for too long.	<ul style="list-style-type: none">Poor connectionFaulty cruise switchFaulty ECM
Enable Conditions	<ul style="list-style-type: none">Engine is runningIgnition voltage $\geq 9V$Cruise control system type is learned	
Threshold value	<ul style="list-style-type: none">Input switch signal is switching too frequently or stuck	
Diagnosis Time	<ul style="list-style-type: none">Switching: more than 1 second failure for 300 seconds testStuck: more than 75 seconds failure for 300 seconds test	
MIL On Condition	<ul style="list-style-type: none">NO MIL ON(DTC only)	

Specification

Item	Resistance(Ω)
ON/OFF switch	$3.9\text{ k}\Omega \pm 5\%$
SET switch	$220\ \Omega \pm 5\%$
RESUME switch	$910\ \Omega \pm 5\%$
CANCEL switch	$0\ \Omega \pm 5\%$

Cruise Control System

Diagnostic Circuit Diagram

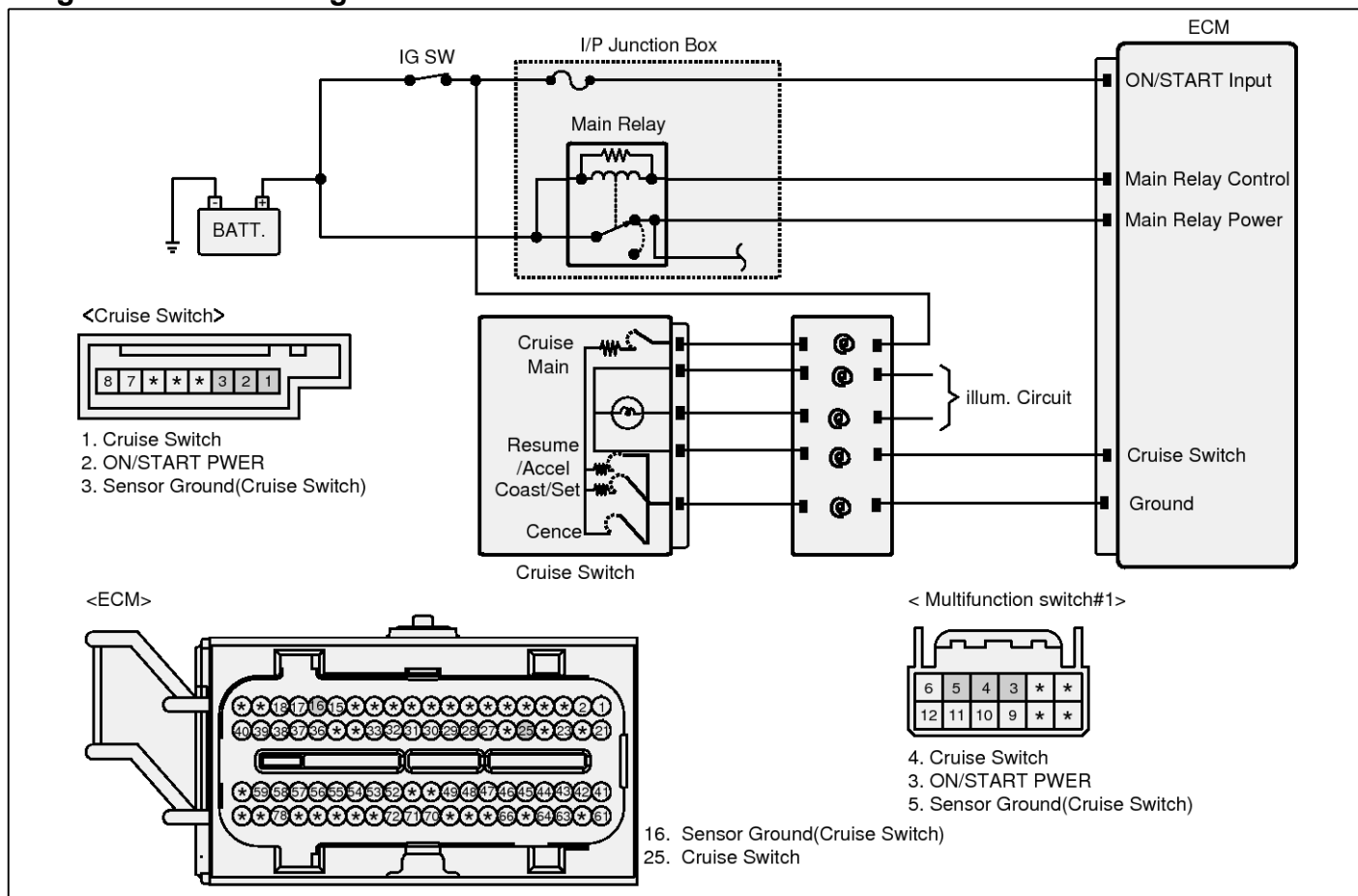

SHMFL9533L

EE-64

Engine Electrical System

Monitor Scantool Data

1. Connect scantool to Data Link Connector(DLC).
2. IG "ON".

3. Select "DTC" button, and then Press "DTC Status" to check DTC's information from the DTCs menu.
4. Read "DTC Status" parameter.

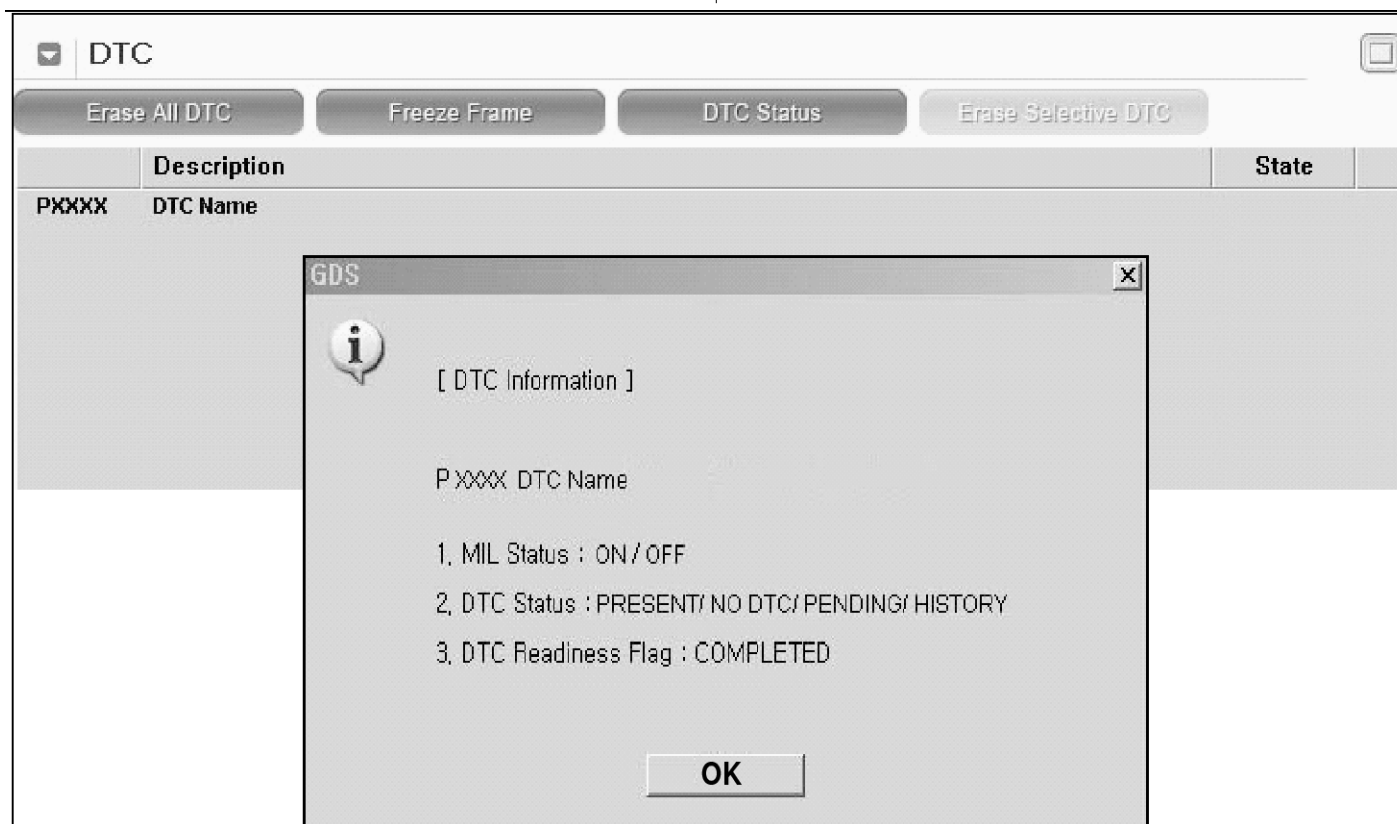

SHMFL9605L

5. Is parameter displayed "Present fault"?

YES ▶ Go to "Terminal and Connector inspection" procedure.

NO ▶ Fault is intermittent caused by poor contact in the sensor's and/or ECM's connector or was repaired and ECM memory was not cleared. Thoroughly check connectors for looseness, poor connection, ending, corrosion, contamination, deterioration, or damage. Repair or replace as necessary and go to "Verification of Vehicle Repair" procedure.

Terminal and Connector inspection

1. Many malfunctions in the electrical system are caused by poor harness and terminals. Faults can also be caused by interference from other electrical systems, and mechanical or chemical damage..
2. Thoroughly check connectors for looseness, poor connection, bending, corrosion, contamination, deterioration, or damage.
3. Has a problem been found?

YES ▶ Repair as necessary and go to "Verification of Vehicle Repair" procedure

NO ▶ Go to "Component Inspection" procedure.

Cruise Control System

Component Inspection

■ Check auto cruise switch

1. IG "OFF" and disconnect Cruise switch connector.
2. Measure resistance between signal and ground terminals of Cruise switch connector with "SET" switch depressed.(Component side)

Specification :

Item	Resistance(Ω)
SET switch	220 Ω \pm 5%

3. Is the measured resistance within specification ?

YES ▶ Substitute with a known - good ECM and check for proper operation. If the problem is corrected, replace ECM and go to "Verification of Vehicle Repair" procedure.

NOTICE

There is a memory reset function on scantool that can erase optional parts automatically detected and memorized by ECM. Before or after testing ECM on the vehicle, use this function to reuse the ECM on the others

NO ▶ Substitute with a known - good auto cruise switch and check for proper operation. If the problem is corrected, replace auto cruise switch and go to "Verification of Vehicle Repair" procedure.

Verification of Vehicle Repair

After a repair, it is essential to verify that the fault has been corrected.

1. Connect scantool and select "DTC" button.
2. Press "DTC Status" button and confirm that "DTC Readiness Flag" indicates "Completed". If not, drive the vehicle within conditions noted in the freeze frame data or enable conditions.
3. Read "DTC Status" parameter.
4. Is parameter displayed "History(Not Present) fault"?

YES ▶ System performing to specification at this time. Clear the DTC.

NO ▶ Go to the applicable troubleshooting procedure.

EE-66

Engine Electrical System

Cruise Control Switch

Circuit Diagram

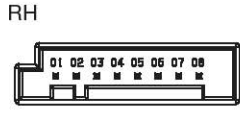
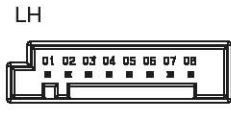
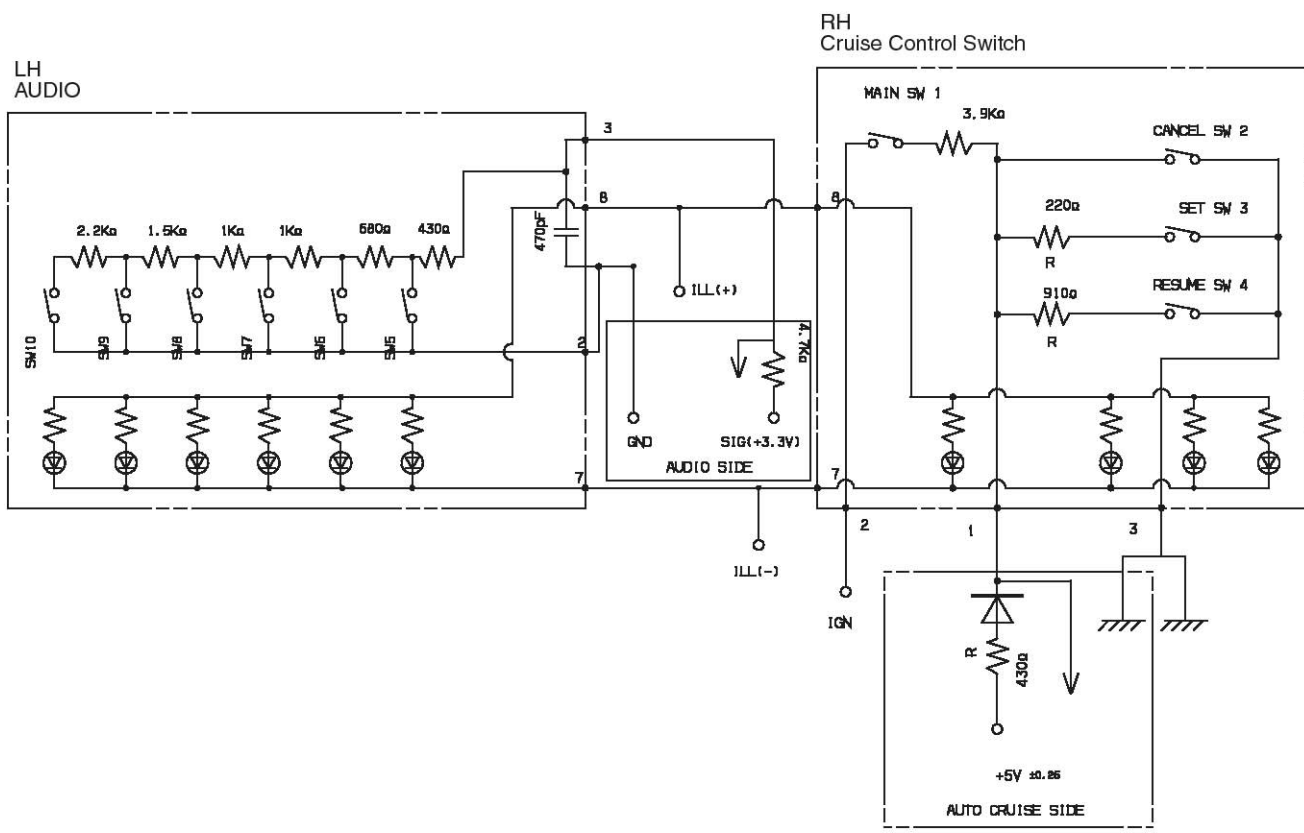

NO	CONNECTOR
1	NC
2	AUDIO H/UNIT (GND)
3	AUDIO H/UNIT (SIG IN)
4	NC
5	NC
6	NC
7	ILL (-)
8	ILL (+)

NO	CONNECTOR
1	CRUISE SW (SIG IN)
2	CRUISE MAIN SW (IGN)
3	CRUISE SW (SIG OUT)
4	NC
5	NC
6	NC
7	ILL (-)
8	ILL (+)

Cruise Control System

EE-67

Removal

1. Disconnect the battery (-) terminal.
2. Remove the air-bag module from the steering wheel. (Refer to RT group)
3. Disconnect the cruise control main switch connector and then remove the cruise control switch.
4. Installation is the reverse of removal.

Inspection

Measuring Resistance

1. Disconnect the cruise control switch connector from the control switch.

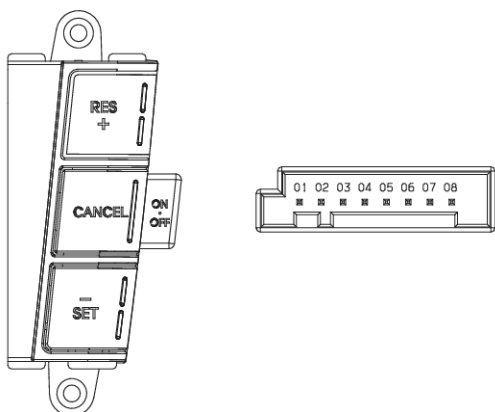

SHMEE9101L

2. Measure resistance between terminals on the control switch when each function switch is ON (switch is depressed).

Function switch	Terminal	Resistance
CANCEL	1-3	0Ω
SET -	1-3	220Ω
RES +	1-3	910Ω
ON / OFF	1-2	3900Ω

3. If not within specification, replace switch.

Measuring Voltage

1. Connect the cruise control switch connector to the control switch.

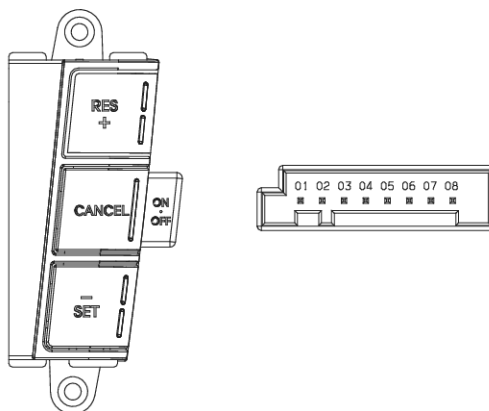

SHMEE9101L

2. Measure voltage between terminals on the harness side connector when each function switch is ON (switch is depressed).

Function switch	Terminal	Voltage
CANCEL	1-3	0V ~ 0.22V
SET -	1-3	1.28V ~ 1.77V
RES +	1-3	2.78V ~ 3.22V
ON / OFF	1-2	-

3. If not within specification, replace switch.