

Automatic Transaxle (A5SR1/2)

GENERAL

AUTOMATIC TRANSAXLE

AUTOMATIC TRANSAXLE SYSTEM

GENERAL

SPECIFICATION EFE42B17

Type		A5SR1	A5SR2
Driving system		2WD/4WD	
T/CON	Type	3 elements, 1 stage, 2 phase	
	Identification inscription [Nominal diameter (mm)]	8 (Φ250)	8 (Φ260)
	Stall torque ratio	1.76	1.84
Transmission	Manipulating system		Remote control flow transmission (Cable method)
	Shift position	P	Fix output axle (Engine start allowed)
		R	Reverse
		N	Neutral (Engine start allowed)
		D	1 2 3 4 5
	Gear ratio	1st	3.827
		2nd	2.368
		3rd	1.520
		4th	1.000
		5th	0.834
		Reverse	2.613
		Final gear ratio	3.333
	Control method		Electronic control
	Function	Lock-up control	Equipped
		Operating fluid pressure control	Equipped
		Real time feedback transmission control	Equipped
		Transmission pattern auto change control	Equipped
		Self-diagnosis control	Equipped
		Fail-safe function	Equipped
		Sports mode function	Equipped
	Speedometer gear teeth (drive/driven)		6/14
	Oil pump	Type	Trochoid oil pump
		Driving system	Engine drive
ATF oil	The recommended	APOLLOIL ATF RED-1	
	Quantity	10 (10.57 US qt, 8.8 Imp.qt)	

AUTOMATIC TRANSAXLE SYSTEM

DESCRIPTION E6A4E767

We have employed A5SR1/ 2, the 5th speed automatic transmission with full range electronic control and sports mode that provides smooth driving with lesser transmission shock as well as pleasant driving from manual transmission.

A/t electronic control system is the system where an optimized transmission has been realized from taking a grasp of driving status, A/T internal status at A/T control unit that has integrated with control valve assembly.

This paper describes apparatus cross-sectional view, major controls and control circuit diagram, major components and their functions, and etc.

A5SR1/ 2

Item	Contents
Improved transmission feel	<ul style="list-style-type: none">- Integrated control over engine and A/T (CAN communication control) system employed- Turbine sensor 1.2 employed- Real time feedback control at all phases applied
Improved driving	<ul style="list-style-type: none">- Sports mode function employed- Snow mode function employed (2WD applied)- Gear ratio extension
Improved fuel consumption	<ul style="list-style-type: none">- Slip lock-up employed- Full range lock-up employed (Larger lock-up zone)- E-flow torque converter employed (Improved driving efficiency)- Small transmission power train employed
Improved safety	<ul style="list-style-type: none">- Transmission lock apparatus (P range maintenance apparatus affixed) employed
Improved maintenance	<ul style="list-style-type: none">- Electronic system diagnosis tester (hi-scan) counterpart

MAJOR COMPONENTS AND THEIR FUNCTIONS

Part name	Acronyms	Function
Front brake	F/B	Fastens the front sun gear
Input clutch	I/ C	Engages the input shaft, with the middle annulus gear and the front annulus gear
Direct clutch	D/C	Engages the rear planetary carrier with a rear sun gear
High & low reverse clutch	H&LR/C	Engages the middle sun gear with the rear sun gear
Reverse brake	R/B	Fastens the rear planetary carrier
Forward brake	FWD/B	Fastens the middle sun gear
Low cost brake	LC/B	Fastens the middle sun gear
1st one-way clutch	1st OWC	Allows the rear sun gear to turn freely forward relative to the mid sun gear but fastens it for reverse rotation
Forward one-way clutch	FWD OWC	Allows the mid sun gear to turn freely in the forward direction but fastens it for reverse rotation
3rd one-way clutch	3rd OWC	Allows the front sun gear to turn freely in the forward direction but fastens it for reverse rotation

AUTOMATIC TRANSAXLE SYSTEM

COMPONENTS

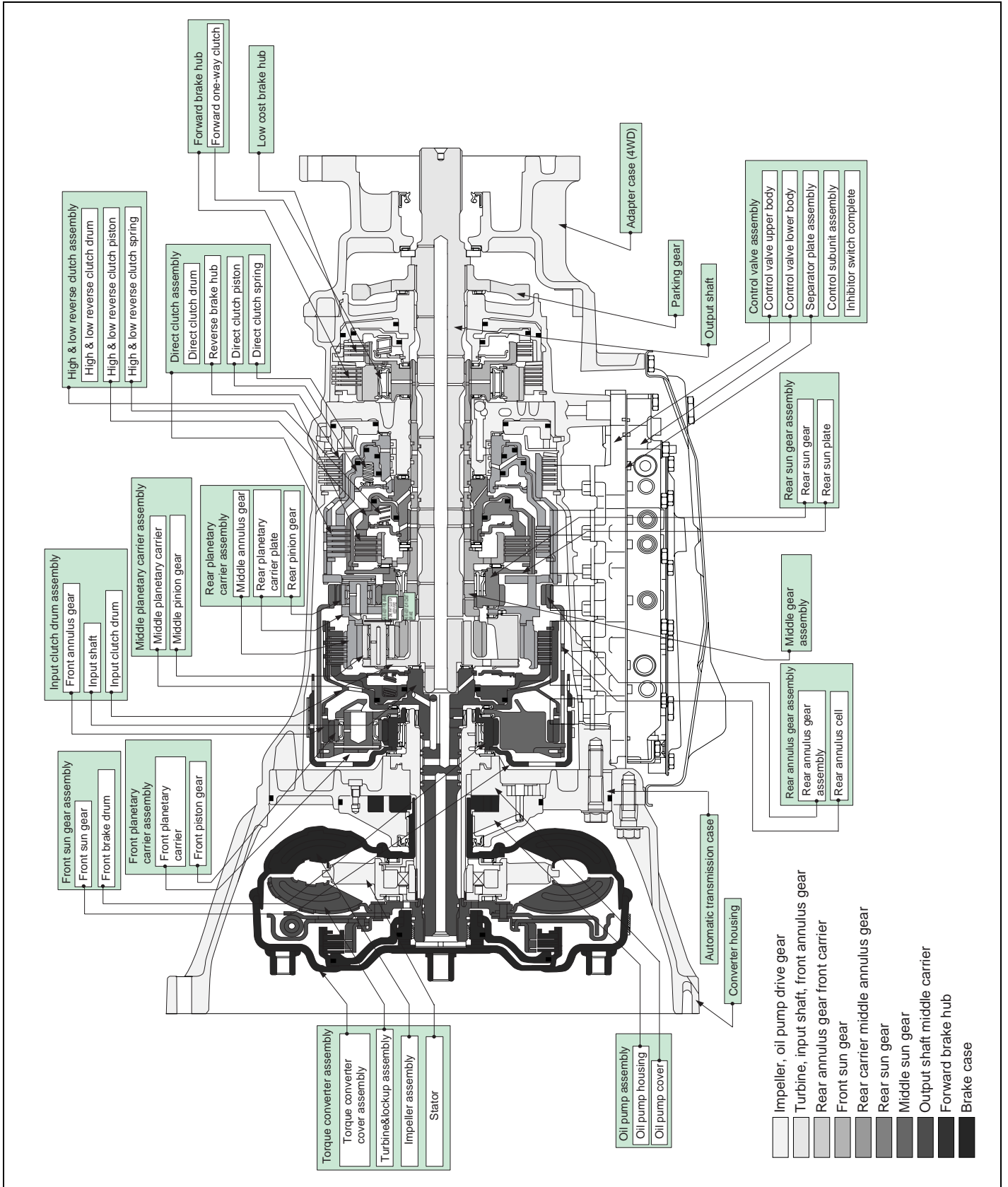

OPERATION

EB4B997D

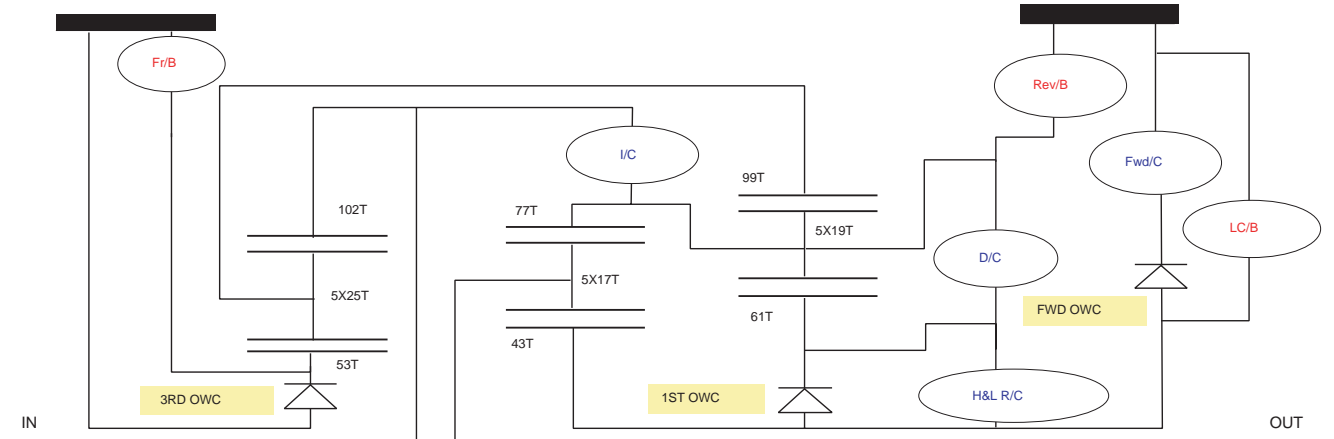

Shift Position	I/C	H&L R/C	D/C	Rev/B	Fr/B	LC/B	Fwd/B	Ratio1 OWC	Forward OWC	Ratio 2 OWC	Remarks
P		△			△						Parking position
R		0		0	0			⊙		⊙	Reverse position
N		△			△	△'''					Neutral position
D	1st	△"			△		0	⊙	⊙	⊙	Automatic shift 1↔2↔3 ↔4↔5
	2nd		0		△		0		⊙	⊙	
	3rd		0	0			△	◇		⊙	
	4th	0	0	0			△	◇			
	5th	0	0				△	◇		◇	
5M	5th	0	0		0		△	◇		◇	Fix to the 5th speed
4M	4th	0	0	0			△	◇			Fix to the 4th speed
3M	3rd		0	0	0		△	◇		⊙	Fix to the 3rd speed
2M	2nd			0	0	0	0		⊙	⊙	Fix to the 2nd speed
1M	1st		0		0	0	0	⊙	⊙	⊙	Fix to the 1st speed

0 : Operates.

⊙ : Operates during progressive acceleration.

◇ : Operates and effects power transmission while coasting.

△ : Line pressure is applied but does not affect power transmission.

△" : Operates under conditions shown in the high & low reverse clutch operating condition.

△''' : Operates under conditions shown in the LC/B operating condition.

Note) Delay control is applied during D(4,3,2,1) ⇒ N shift.

AUTOMATIC TRANSAXLE SYSTEM

OPERATING PRINCIPLES OF EACH RANGE

1. N range
Since the forward and reverse brakes are released, driving force of input shaft is not transmitted to output shaft.
2. P range
 - Since the forward and reverse brakes are released, as those in the N range, driving force of input shaft is not transmitted to output shaft.
 - Parking pawl that is linked with select lever parking gear meshes with and fastens output shaft mechanically.
3. D, M2, M3, M4, M5 range 1st speed
 - Fastens the front brake.
 - The front brake and the forward one-way clutch regulate reverse rotation of the mid sun gear.
 - The 1st one-way clutch regulates reverse rotation of the rear sun gear.
 - The 3rd one-way clutch regulates reverse rotation of the front sun gear.

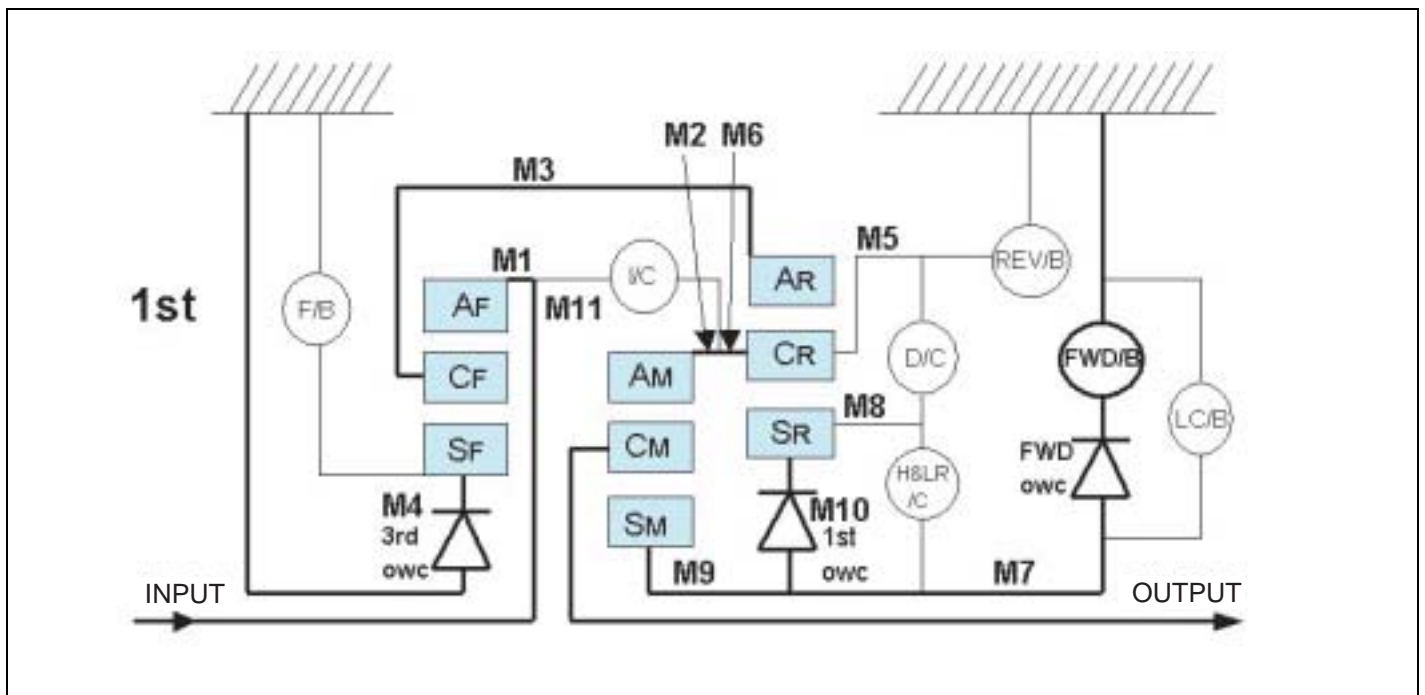

LLAE002A

- Since the middle sun gear rotates forward during deceleration, the forward one-way clutch runs idle and engine brake is not activated.

*** POWER FLOW**

Input shaft Front internal gear Front carrier Rear internal gear Rear carrier Middle internal gear Middle carrier Output shaft

- 4. D, M3, M4, M5 range ratio 2nd
 - Fasten the front brake.
 - The front brake and the forward one-way clutch regulate reverse rotation of the mid sun gear.
- The 3rd one-way clutch regulates reverse rotation of the front sun gear.

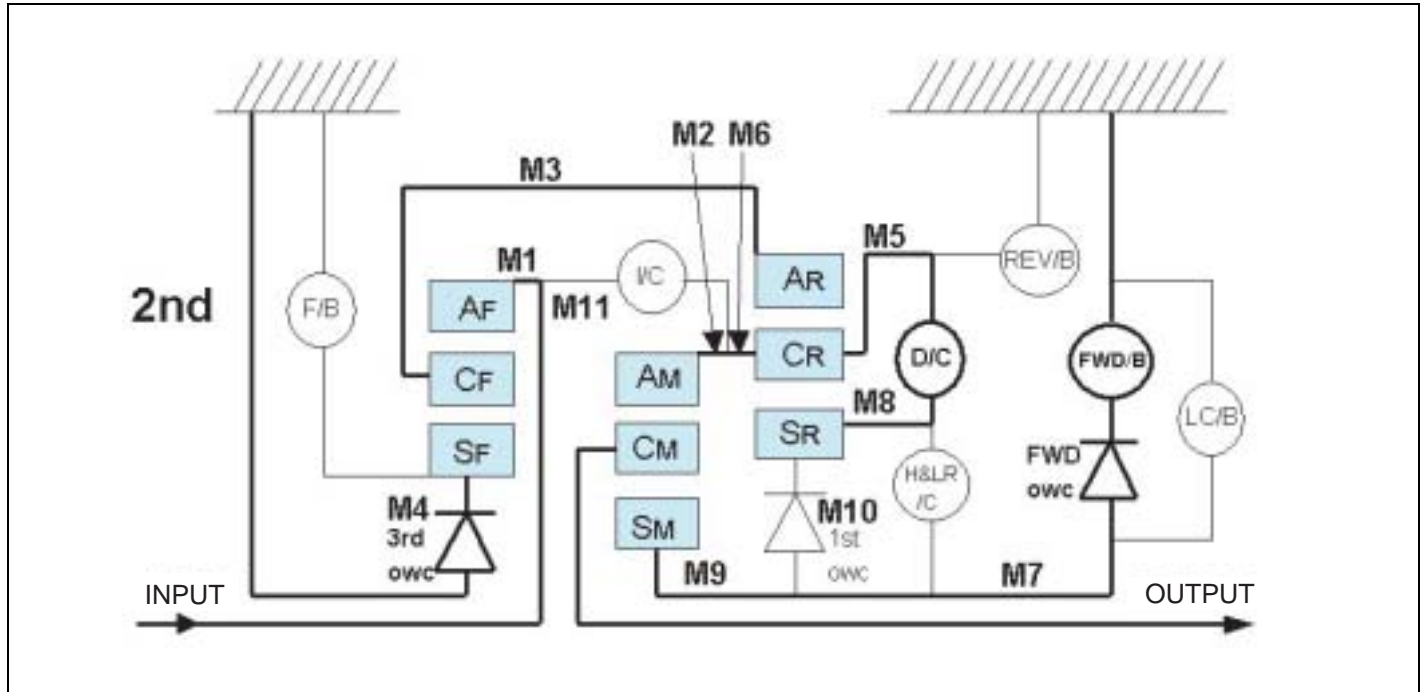

LLAE002B

The direct clutch is coupled and the rear carrier and the rear sun gear are connected.

*** POWER FLOW**

Input shaft Front internal gear Front carrier Rear internal gear Rear carrier Rear carrier Middle internal gear Middle carrier Output shaft

- 5. D, M3, M4, M5 range 3rd speed
 - Fastens the front brake.

- The 3rd one-way clutch regulates reverse rotation of the front sun gear.

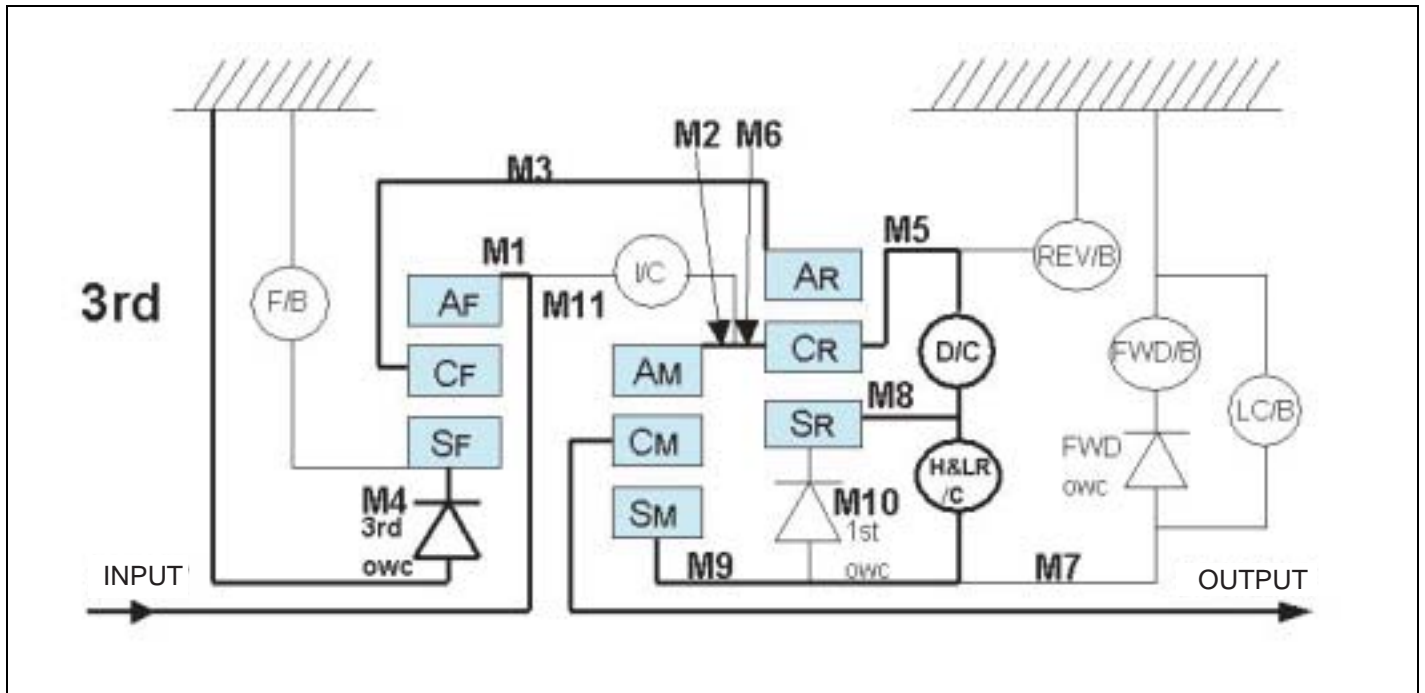

LLAE002C

- The high & low reverse clutch is coupled and the middle and rear sun gears are connected.

*** POWER FLOW**

Input shaft Front internal gear Front carrier Rear internal gear Rear carrier Rear carrier Middle internal gear Middle carrier Output shaft

6. D, M4, M5 range 4th speed
- The front brake is released and sun gear turns freely forward.
 - The input clutch is coupled and the front and middle internal gears are connected.

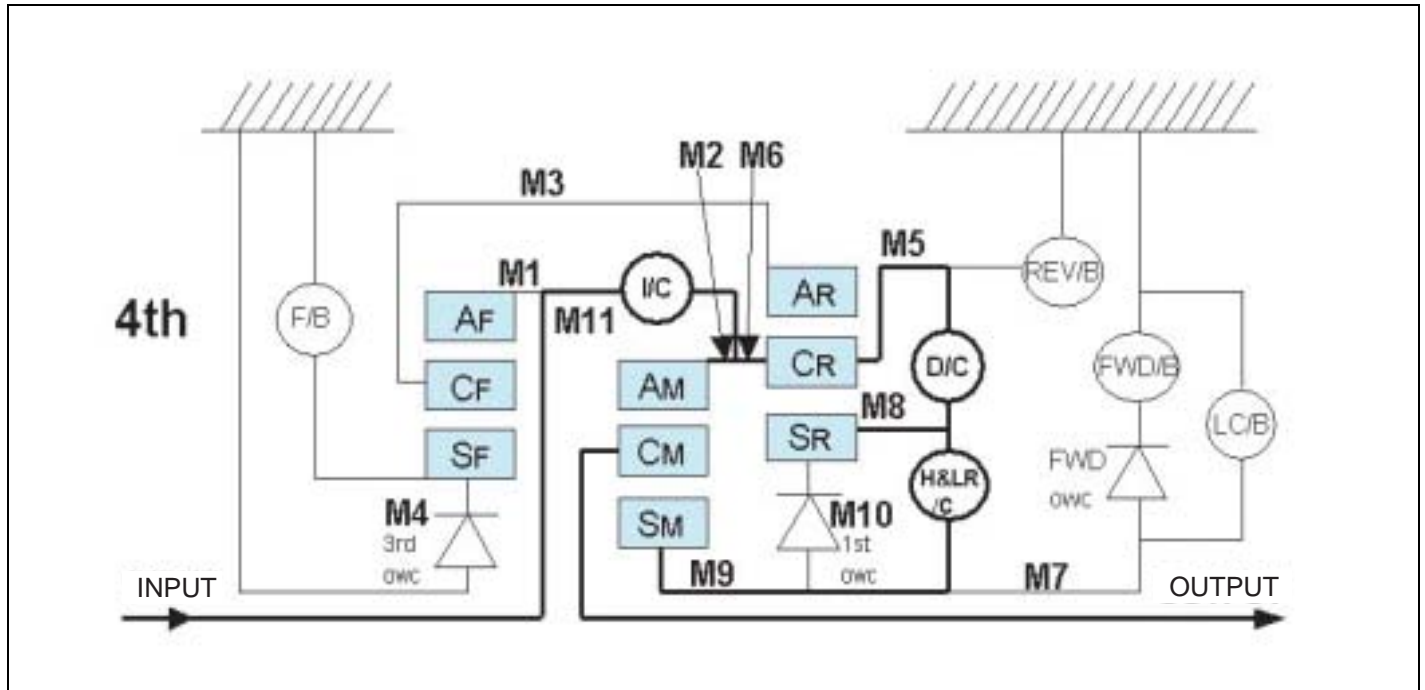

LLAE002D

- Driving force is conveyed to the front internal gear, the middle internal gear, and the rear carrier and the three planetary gears rotate forward as a unit.

*** POWER FLOW**

Input shaft Front internal gear Front carrier Rear internal gear Rear carrier Middle internal carrier Middle carrier Output shaft

7. D, M5 range 5th speed
- The front brake fastens the front sun gear.
 - The direct clutch is released and the rear carrier and rear sun gear are disconnected.

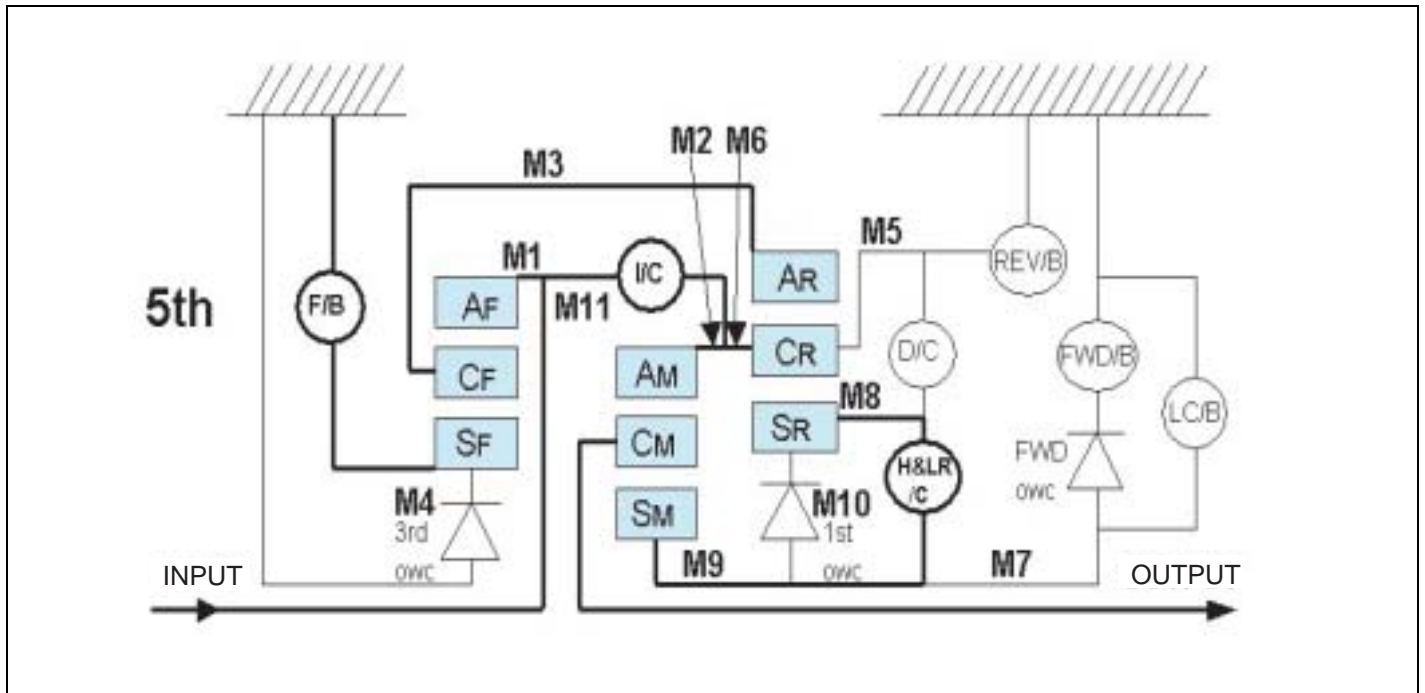

LLAE002E

*** POWER FLOW**

Input shaft Front internal Front carrier Rear
 internal input shaft Middle internal Rear
 carrier Rear sun gear Middle sun carrier Middle
 carrier Output shaft

8. R range

- The front brake fastens the front sun gear.
- The high & low reverse clutch is coupled and the middle and rear sun gears are connected.
- The reverse brake fastens the rear carrier.

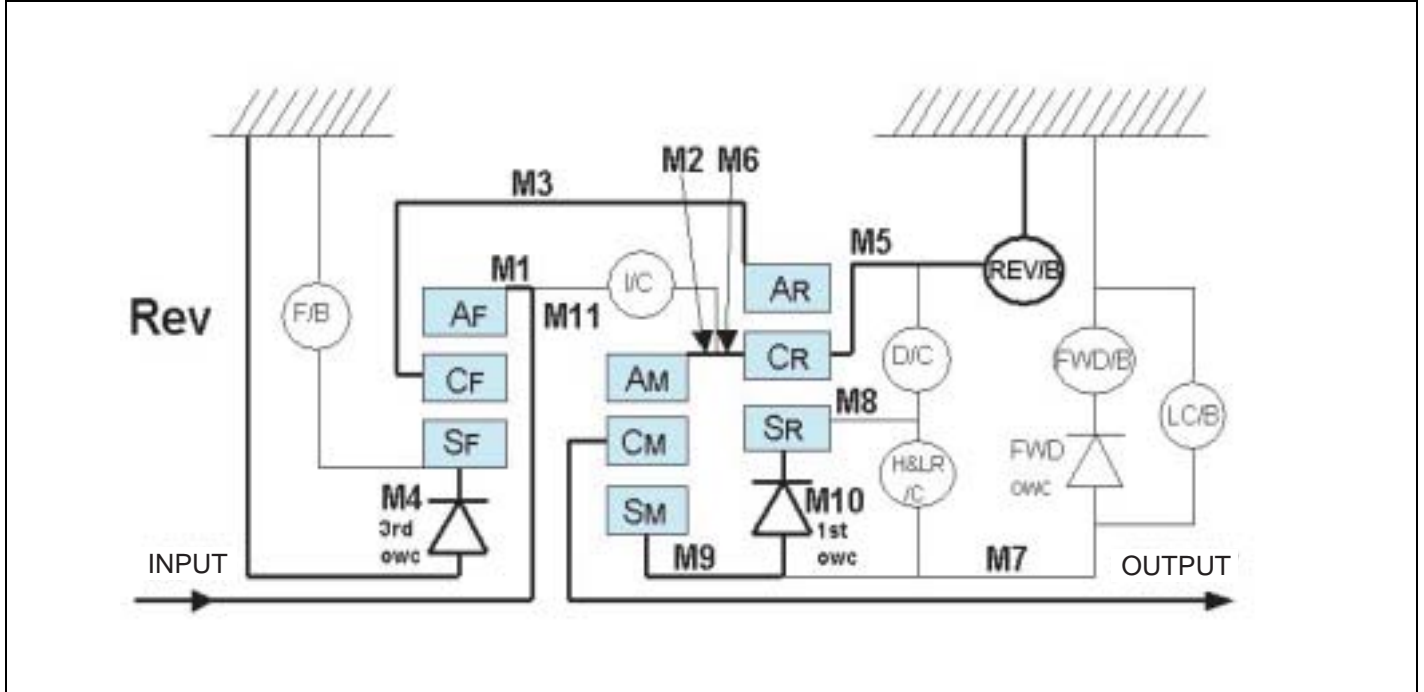

LLAE002F

*** POWER FLOW**

Input shaft Front internal Front carrier Rear internal
Rear sun gear Middle sun gear Middle carrier
Output shaft

CONTROL SYSTEM DIAGRAM

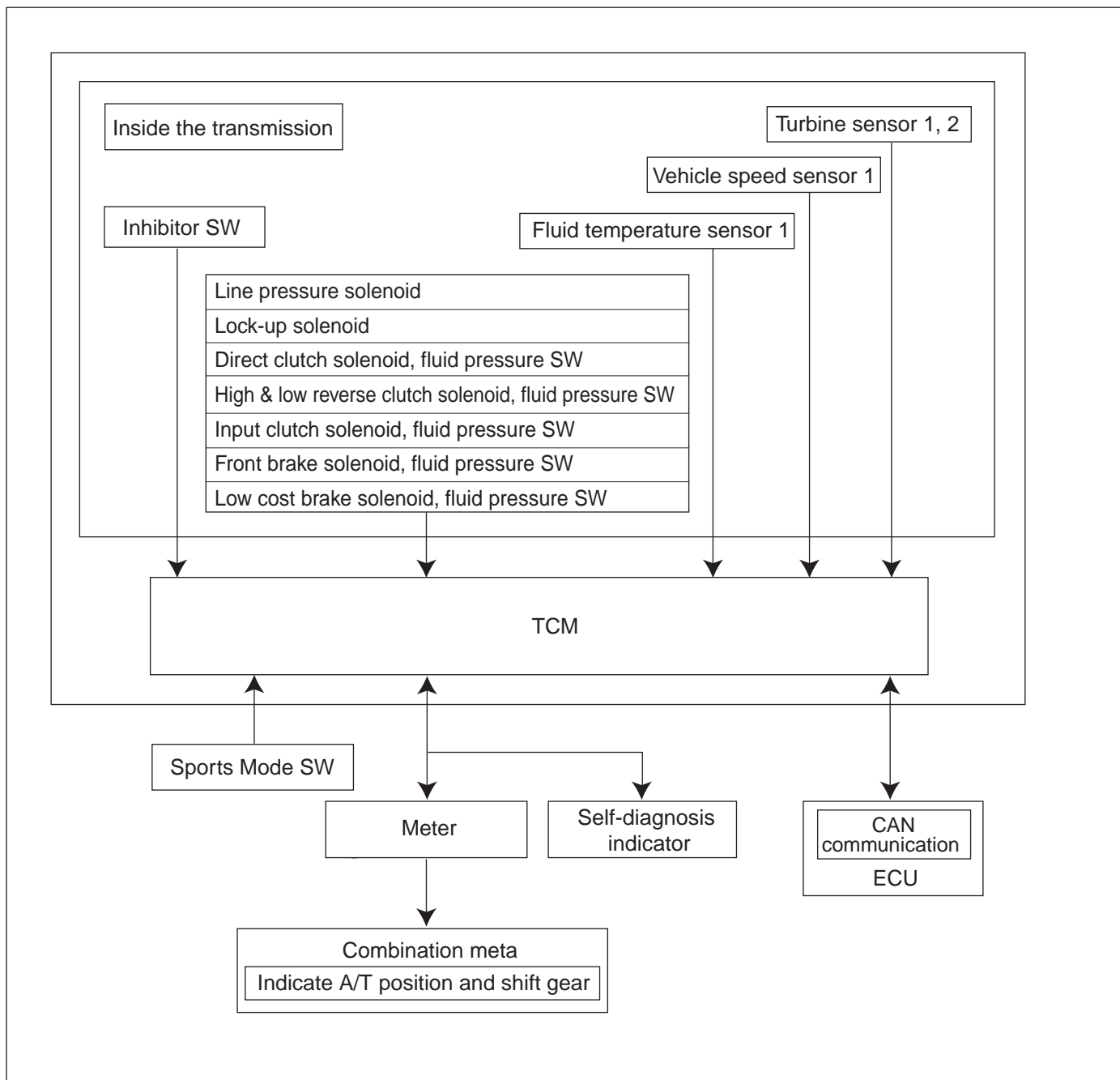

LLAE002G

MAIN COMMUNICATION SIGNAL

Input to ECM (CAN)	Output to ECM(CAN)	Input from external sys.	Output to external sys.
-	-	A/T driving mode SW	Self-diagnosis indicator
Engine torque signal	Output revolution signal	Sports mode SW	Range signal (P, R, N, D)
Engine revolution signal	Turbine sensor signal	Up SW	Range signal
-	Torque reduction request signal	Down SW	Reverse lamp signal
Accelerator opening signal		Stop lamp SW	N position signal
Power		4x4 Low signal	

LINE PRESSURE CONTROL

- If the engine control unit sends the input torque signal equivalent to the engine driving force to the A/T control unit (TCM), the A/T control unit (TCM) controls line pressure solenoid.
- This line pressure solenoid controls the pressure regulator valve as the signal pressure and adjusts the pressure of the operating oil discharged from the oil pump to the line pressure most appropriate to the driving plate.

LINE PRESSURE SYSTEM DIAGRAM

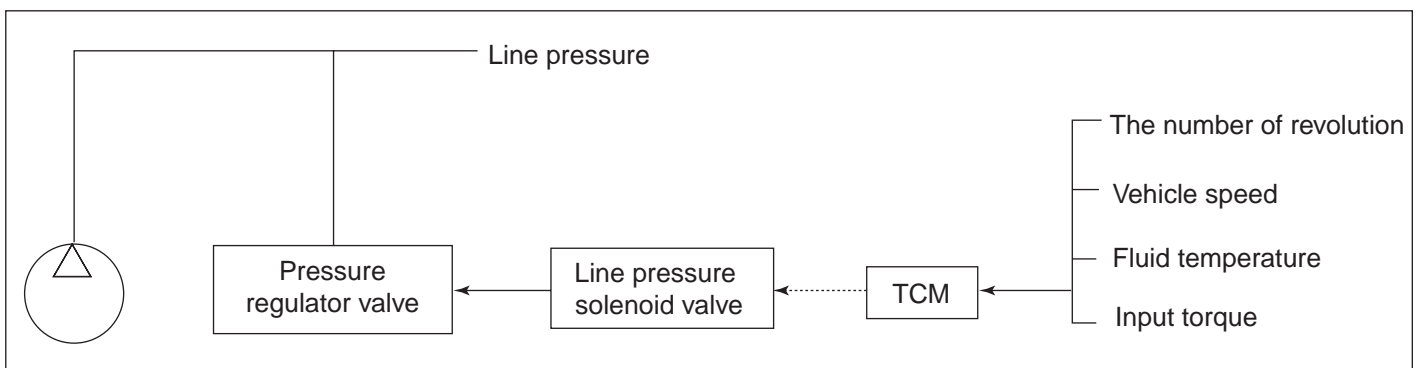

LLAE002H

LINE PRESSURE CONTROL BASED ON LINE PRESSURE CHARACTERISTIC PATTERN OF A/T CONTROL UNIT (TCM)

- A/T control unit (TCM) has stored in memory a number of patterns for the optimum line pressure characteristics according to driving conditions.
- In order to obtain the most appropriate line pressure characteristic to meet the current driving state, the TCM controls the line pressure solenoid current valve and thus controls the line pressure.
 - Normal line pressure control.
Each clutch is adjusted to the necessary pressure to match the engine drive force.

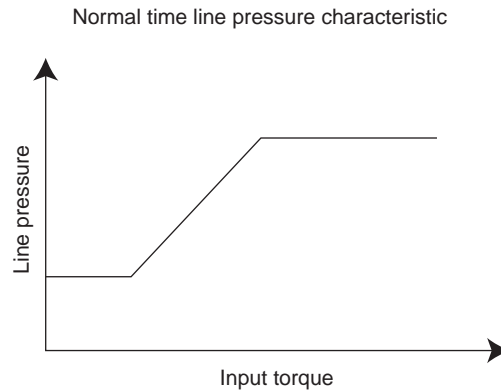

LLAE002I

- Back-up control (Engine brake)
Line pressure according to speed is set during shift down by select operation while driving.

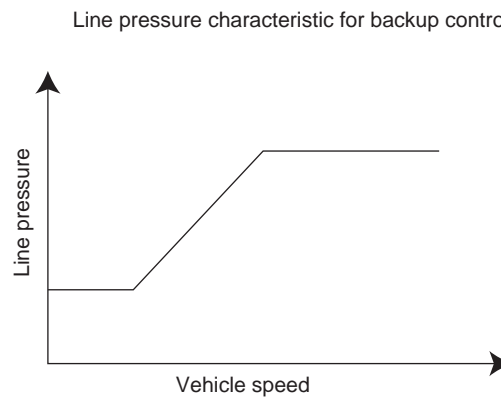

LLAE002J

- During shift change
Set to line pressure that is necessary for shift change. Therefore, line pressure characteristic is set according to input torque and shift types.

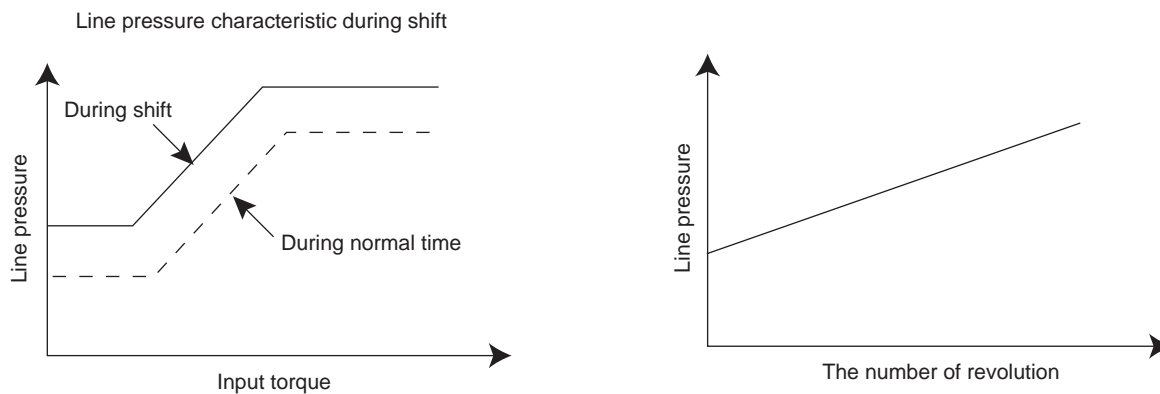

LLAE002K

- At low fluid temperature
When the A/T fluid temperature drops below the prescribed temperature, in order to speed up the action of each friction element, the line pressure is set higher than the normal line pressure characteristic.

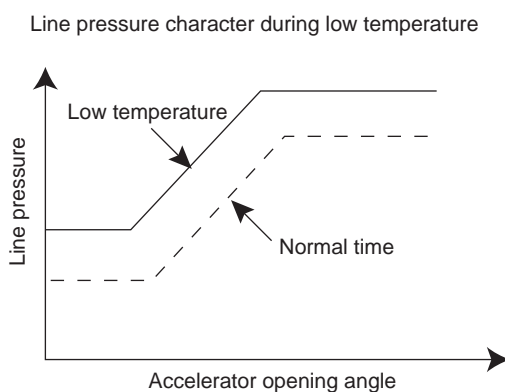

LLAE002L

SHIFT CONTROL

- The clutch pressure control solenoid is controlled by the signals from the switches and sensors. Thus the clutch pressure is adjusted to be appropriate to the engine load state and vehicle driving state. It becomes possible to finely control the clutch hydraulic pressure with high precision and a smoother shift change characteristic is attained.

SHIFT CONTROL SYSTEM DIAGRAM

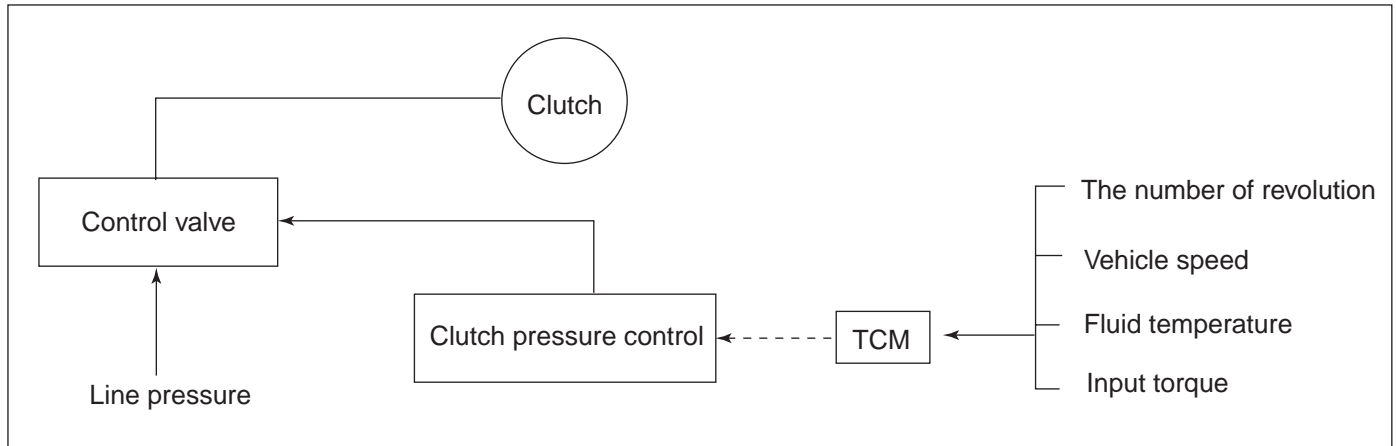

LLAE002M

Shift description

Controls clutches with optimum timing and fluid pressure in response to engine speed, engine torque information, and etc.

LOCK-UP CONTROL

Lock-up control is to enhance delivery efficiency by preventing the torque converter from slipping, engaging the lock-up piston into the torque converter.

It operates lock-up solenoid control in response to a signal from A/T control unit (TCM) and lock-up control valve behavior control, engages or releases the lock up piston of the torque converter.

LOCK-UP OPERATING CONDITION TABLE

Select lever	D range			Sports mode	
Gear position	5	4	3	5	4
Lock-up	○	-	-	○	○
Slip lock-up	○	○	-	-	-

LLAE002N

Lock-up control valve control

- In the lock-up control valve, there is operating fluid pressure circuit linked into the lock-up piston and lock-up solenoid operates valve shift in response to a signal from the A/T control unit.
- Operating fluid pressure circuit that is applied to the lock-up piston chamber is controlled with the release or apply sides.

LOCK-UP CONTROL SYSTEM DIAGRAM

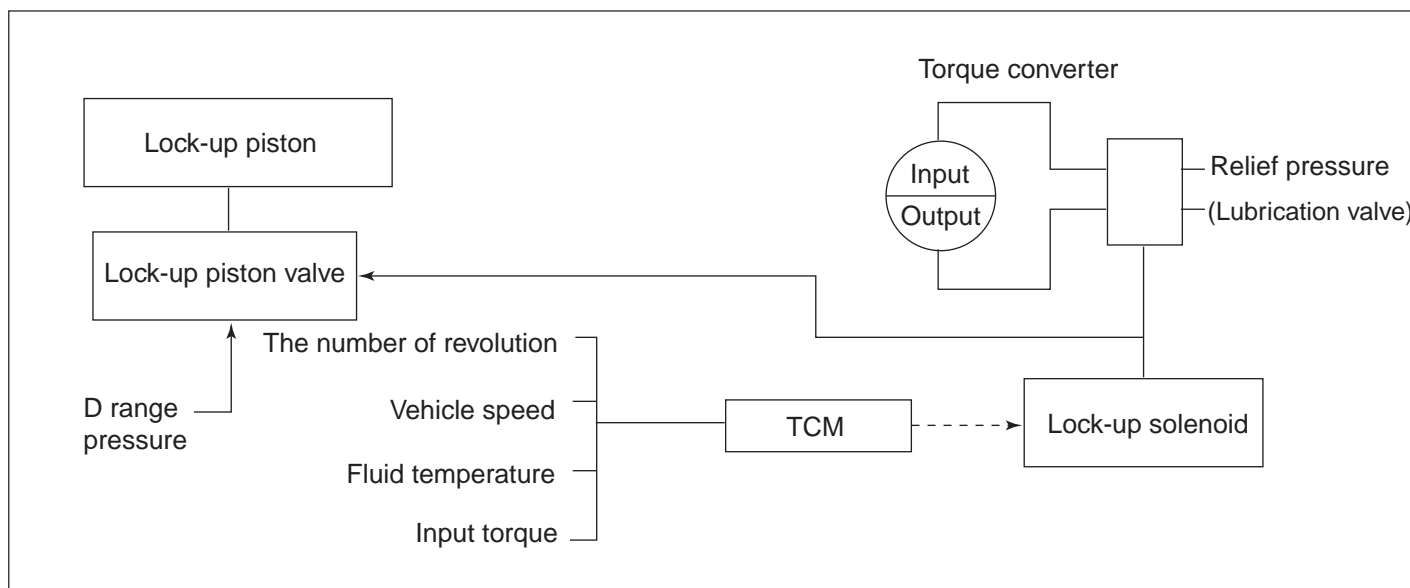

Lock-up released

- In the lock-up control valve, there is operating fluid pressure circuit connected into the lock-up piston and lock-up solenoid operates valve shift in response to a signal from the A/T control unit. Therefore, the lock-up piston is not coupled.

Lock-up applied

- During the lock-up applied status, lock-up apply pressure is generated having the lock-up control valve to L/U by the lock-up solenoid. Therefore, press the lock-up piston to be coupled.

Smooth lock-up control

- A/T control unit (TCM) controls current value that is output to the lock-up solenoid when shifting lock-up applied state from lock-up released state. Therefore the lock-up clutch is temporarily set to half-clutched state when shifting the lock-up applied state to reduce the shock.

Half-clutched state

- Changes current value that is output to the lock-up solenoid from A/T control unit (TCM) to gradually increase lock-up solenoid pressure. In this way, the lock up apply pressure gradually rises and while the lock-up piston is put into half-clutched status, the lock-up piston operating pressure is increased and the coupling is completed smoothly.

Slip lock-up control

- In the slip region, A/T control unit controls current value of the lock-up solenoid to half-clutched status. Therefore lock-up operates from low speed absorbing torque fluctuation of engine. Thereby fuel consumption was increased during low accelerator opening with 4th, and 5th gears at low speed.

ENGINE BRAKE CONTROL

- The forward one-way clutch delivers driving force from the engine to the rear wheel but reverse driving from the wheel drive is not delivered since the one-way clutch is idling. Therefore low coast brake solenoid is operated to prevent the forward one-way clutch from idling so that the engine brake is operated in the same as before.

ENGINE BRAKE CONTROL SYSTEM DIAGRAM

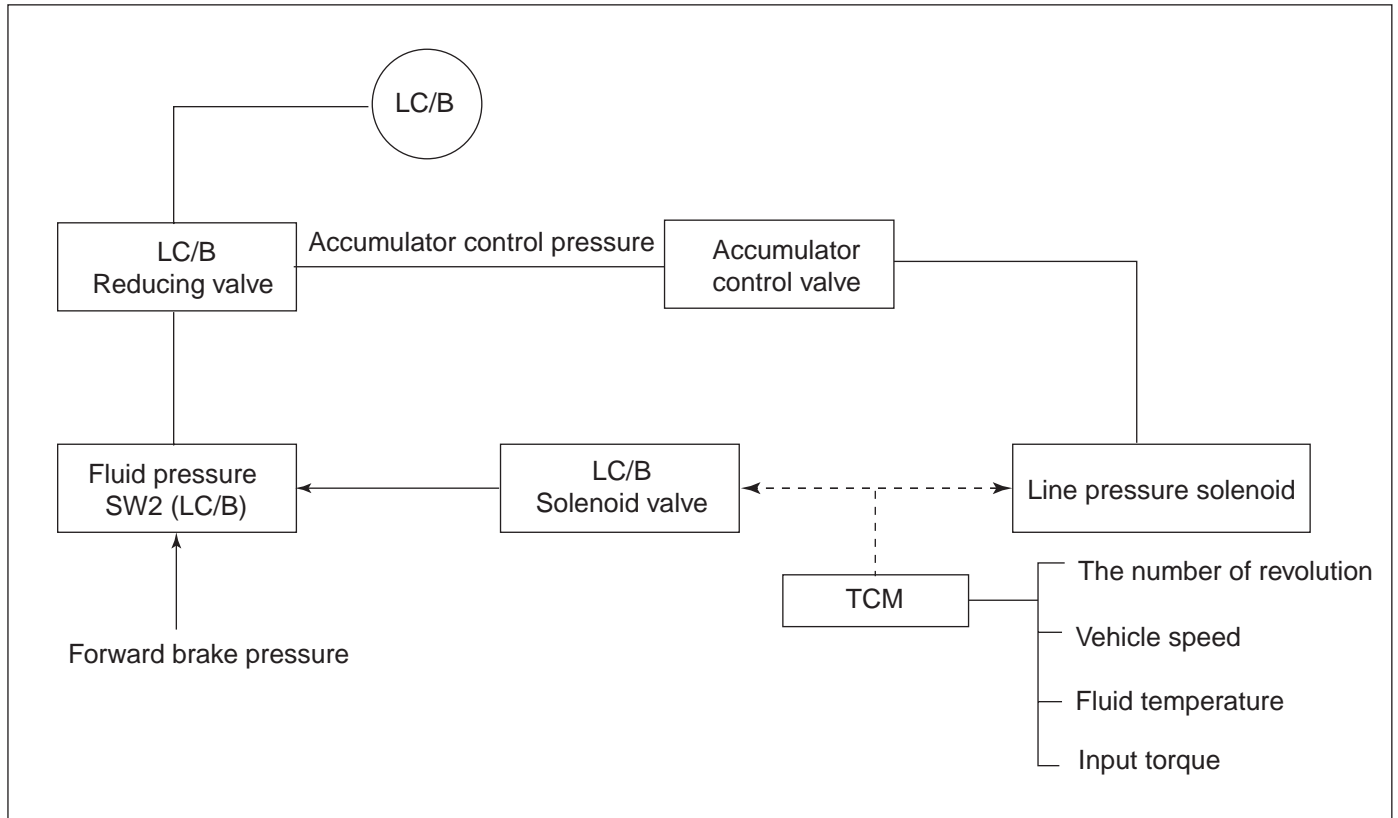

LLAE002P

- The operation of the low coast brake solenoid switches the low coast brake switch valve and controls the coupling and releasing of the low coast brake. The low coast brake reducing valve controls the low coast brake coupling force.

CONTROL VALVE

CONTROL VALVE FUNCTIONS

Valve name	Function
Torque converter regulator valve	Regulates line pressure to the optimum pressure (torque converter operating pressure) to prevent pressure applied to the torque converter from being excessive.
Pressure regulator valve Pressure regulator plug Pressure regulator sleeve	Regulates oil pump discharge pressure to the optimum pressure (line pressure) in response to the driving conditions.
Front brake control valve	Regulates line pressure to the optimum pressure (front brake pressure) to be applied to the front brake during the front brake apply.
Accumulator control valve	Regulates pressure applied to the accumulator piston, and the low coast reducing valve (accumulator control pressure) in response to the driving conditions (regulates clutch pressure at 1st, 2nd, 3rd, 5th gears).
Pilot valve A	Regulates line pressure to the regular pressure required by line pressure control, shift control, and lock-up control (pilot pressure).
Pilot valve B	Regulates line pressure to the regular pressure required by shift control (pilot pressure).
Low coast brake switching valve	Provides the low coast brake reducing valve with line pressure during engine brake operation.
Low coast brake reducing valve	Regulates line pressure to the optimum pressure to be applied to the low coast brake when the low coast brake is coupled.
N-R accumulator	Produces the stabilizing pressure for when N-R is selected.
Direct clutch piston switching valve	Operates in 4th gear and switches the direct clutch coupling capacity.
High & low reverse clutch control valve	Regulates line pressure to the optimum pressure (high & low reverse clutch pressure) to be applied to the high & low reverse clutch when the high & low reverse clutch is coupled (regulates clutch pressure in 1st, 3rd, 4th, 5th gears).
Input clutch control valve	Regulates line pressure to the optimum pressure (input clutch pressure) to be applied to the input clutch when the input clutch is coupled (regulates clutch pressure in 4th, 5th gears).
Direct clutch control valve	Regulates line pressure to the optimum pressure (direct clutch pressure) to be applied to the direct clutch when the direct clutch is coupled (regulates clutch pressure in 2nd, 3rd, 4th gears).
Lock-up control valve Lock-up control plug Lock-up control sleeve	Switches lock-up to operating or released. Also, by performing the lock-up operation transiently, lock-up smoothly.
Torque converter lubrication valve	Operates to switch torque converter, cooling, and oil path of lubrication system during lock-up.
Cool bypass valve	Allows excess oil to by pass cooler circuit without being fed into it.
Line pressure relief valve	Discharges excess oil from line pressure circuit.
N-D accumulator	Produces the stabilizing pressure for when N-D is selected.
Manual valve	Delivers line pressure to each circuit in response to each select position. Circuit to which line pressure is not sent drain.

FUNCTION OF PRESSURE SWITCH

Name	Function
Fluid pressure switch 1 (FR/B)	Detects abnormal fluid pressure of the front brake. When it detects any malfunction, it puts the system into fail-safe mode.
Fluid pressure switch 2(LC/B)	Detects abnormal fluid pressure of the low coast brake. When it detects any malfunction, it puts the system into fail-safe mode.
Fluid pressure switch 3(I/C)	Detects abnormal fluid pressure of the input clutch. When it detects any malfunction, it puts the system into fail-safe mode.
Fluid pressure switch 5(D/C)	Detects abnormal fluid pressure of the direct clutch. When it detects any malfunction, it puts the system into fail-safe mode.
Fluid pressure switch 6(H&LR/C)	Detects abnormal fluid pressure of the high & low reverse clutch. When it detects any malfunction, it puts the system into fail-safe mode.

SUB ROM UNIT

1. Installing location: The valve body upper part
2. Function: To obtain A/T fluid pressure stability by compensating for solenoid & valve body unit fluid pressure differential.
3. Principle: Install additional ROM onto valve body of automatic transmission and input fluid pressure differential of solenoid & valve body so that TCM reads the input data to perform fluid pressure compensation.

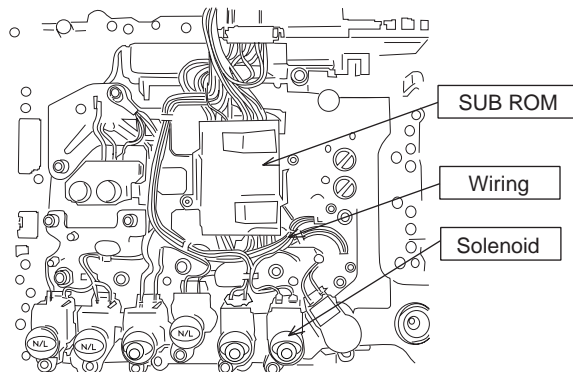

LLAE117A

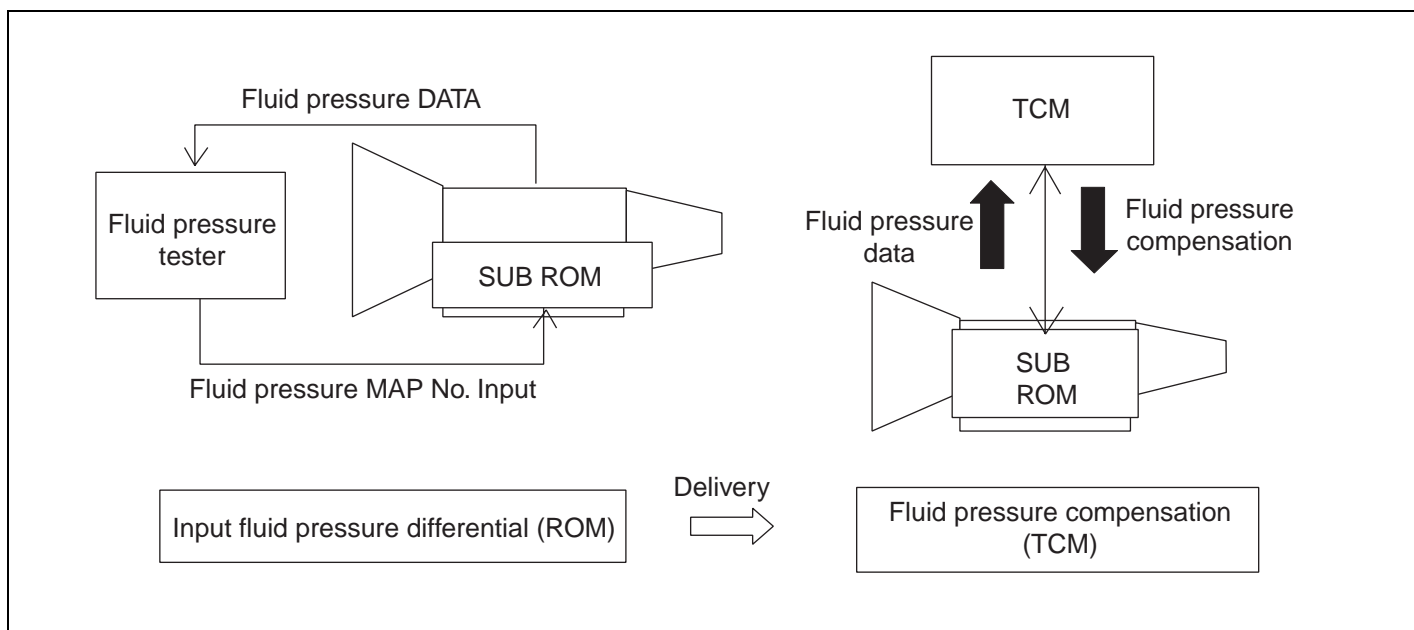

LLAE117B

4. Maintenance

- 1) When replacing with a new TCM in the vehicle
 - TCM automatically reads SUB ROM DATA during I.G ON. At this time, shift range valve is off for about 2.5 second.
- 2) When replacing A/T (regardless of new or old ones) in the vehicle
 - Must erase SUB ROM DATA stored in TCM.
 - Erase SUB ROM DATA in SCAN TOOL delete mode during shift stage in R-range + accelerator opening angle maintains 50% + I.G ON.
 - TCM reads SUB ROM DATA from a new A/T upon I.G ON again after I.G OFF.
- 3) Moving TCM from vehicle A to another vehicle B
 - Perform the same way as in 2) above.

AUTOMATIC TRANSAXLE SYSTEM

**VALVE BODY FLUID PRESSURE CIRCUIT
DIAGRAM (D RANGE) E5EB94AB**

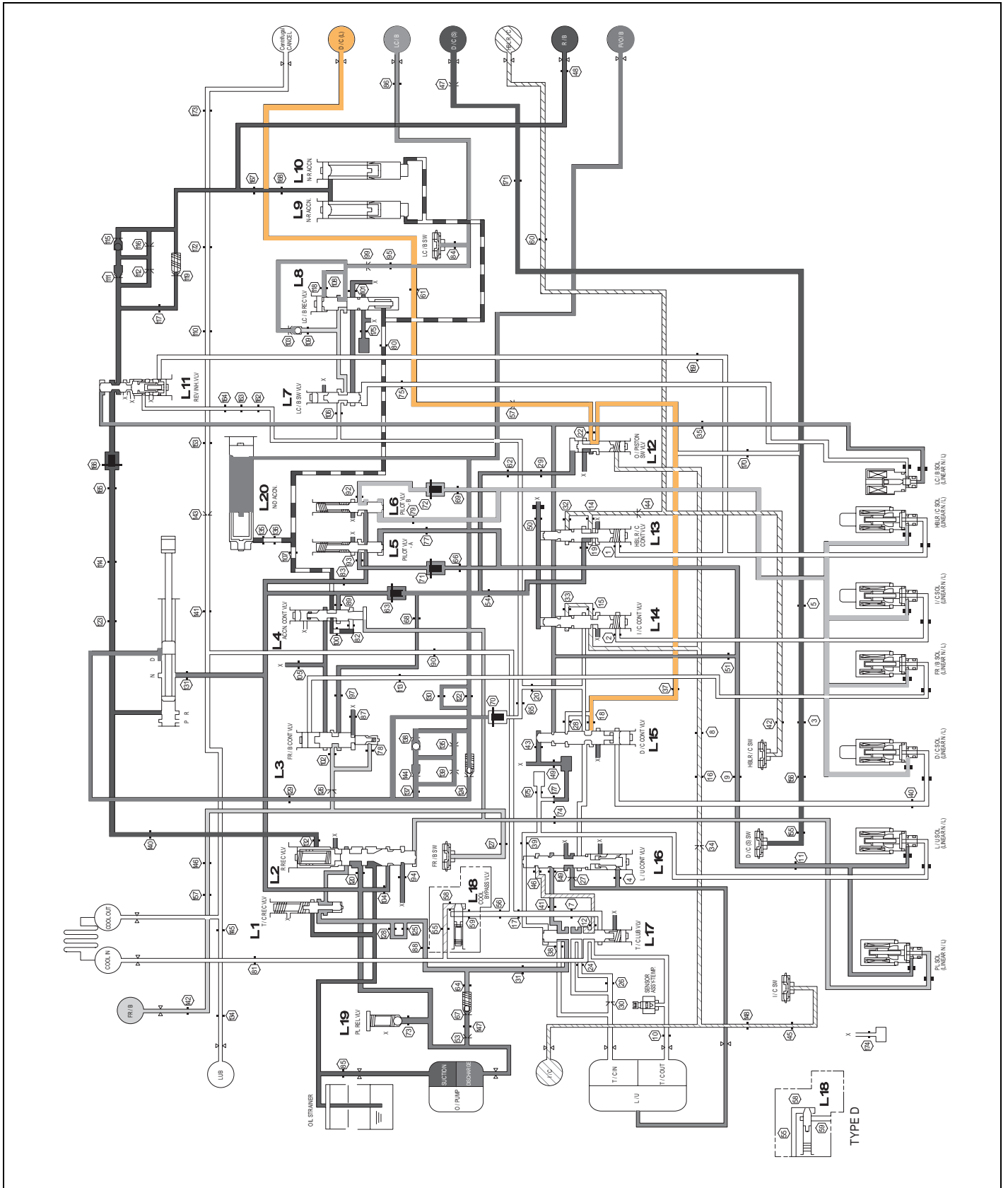

LLAE006A

* Refer to body valves for L(number) valve name.

1ST GEAR

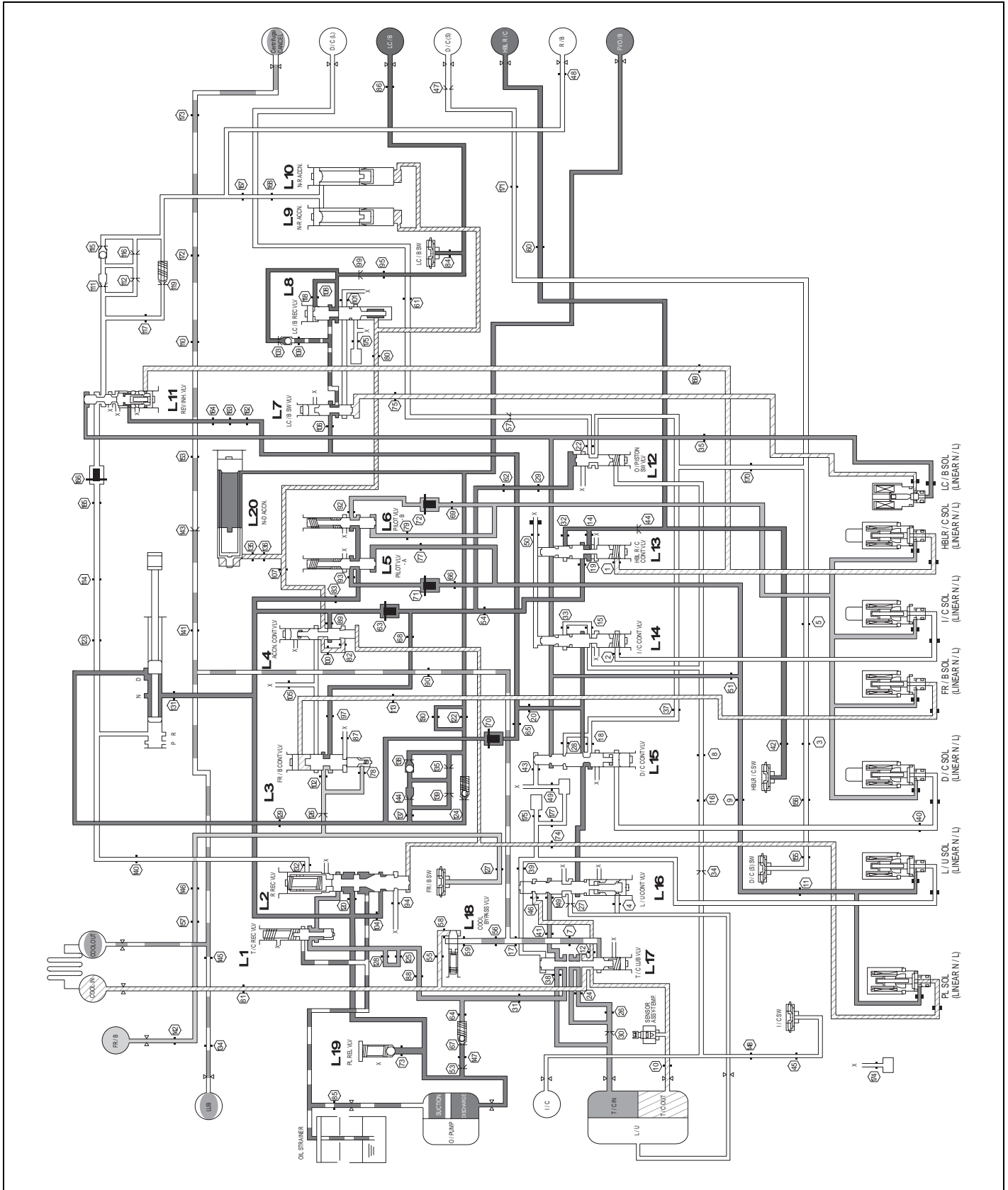

LLAE006B

AUTOMATIC TRANSAXLE SYSTEM

2ND GEAR

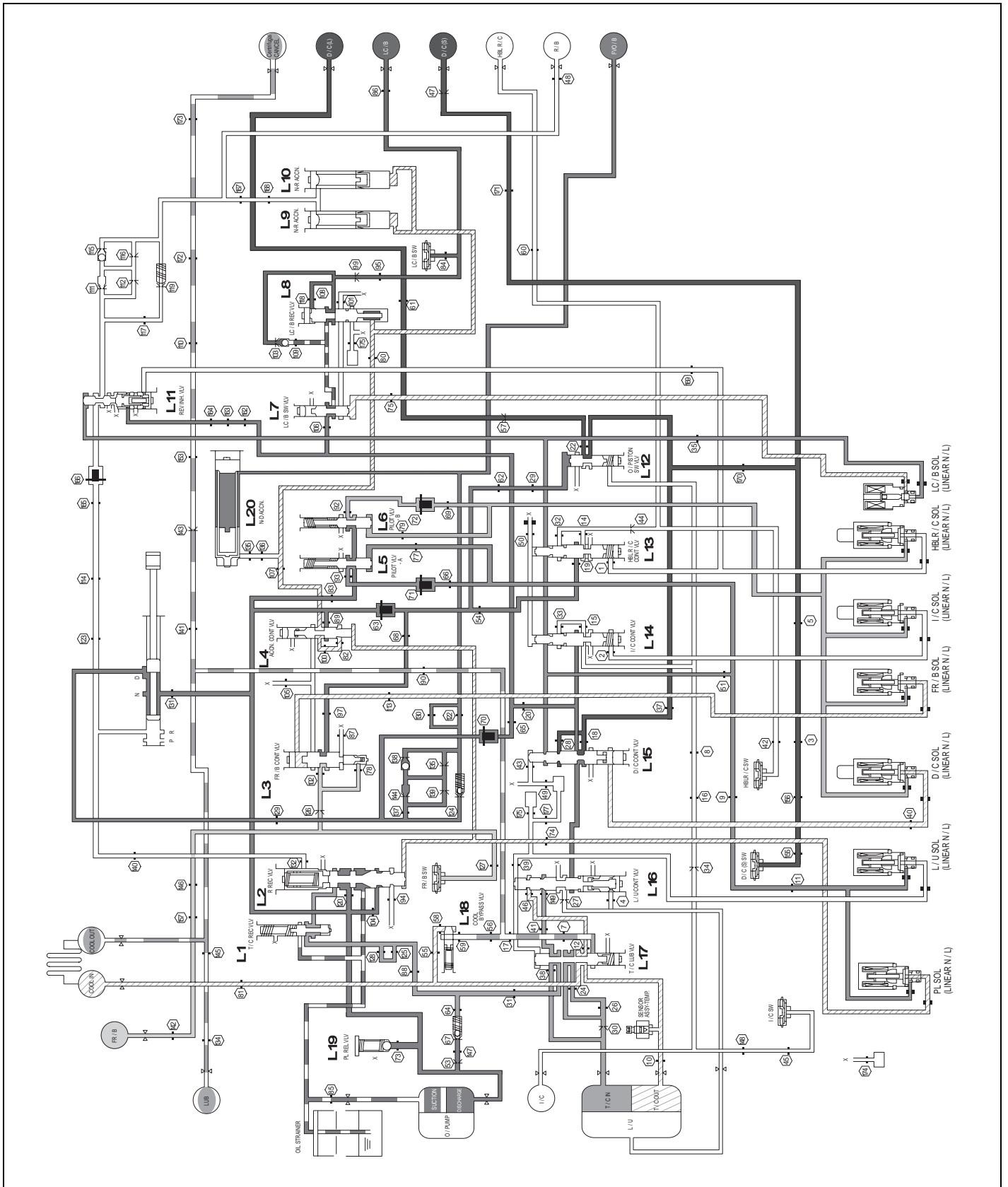

LLAE006C

3RD GEAR

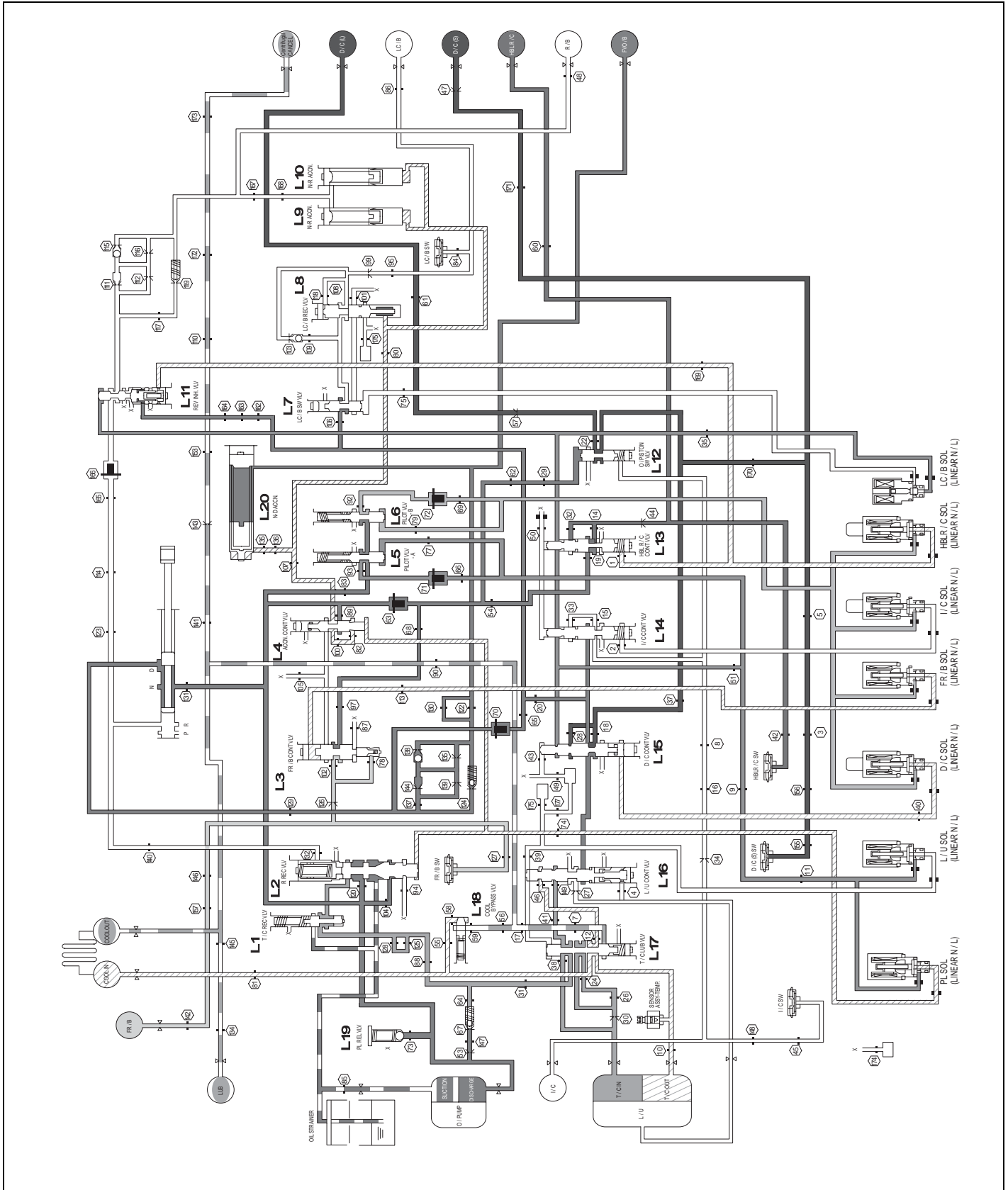

LLAE006D

AUTOMATIC TRANSAXLE SYSTEM

4TH GEAR

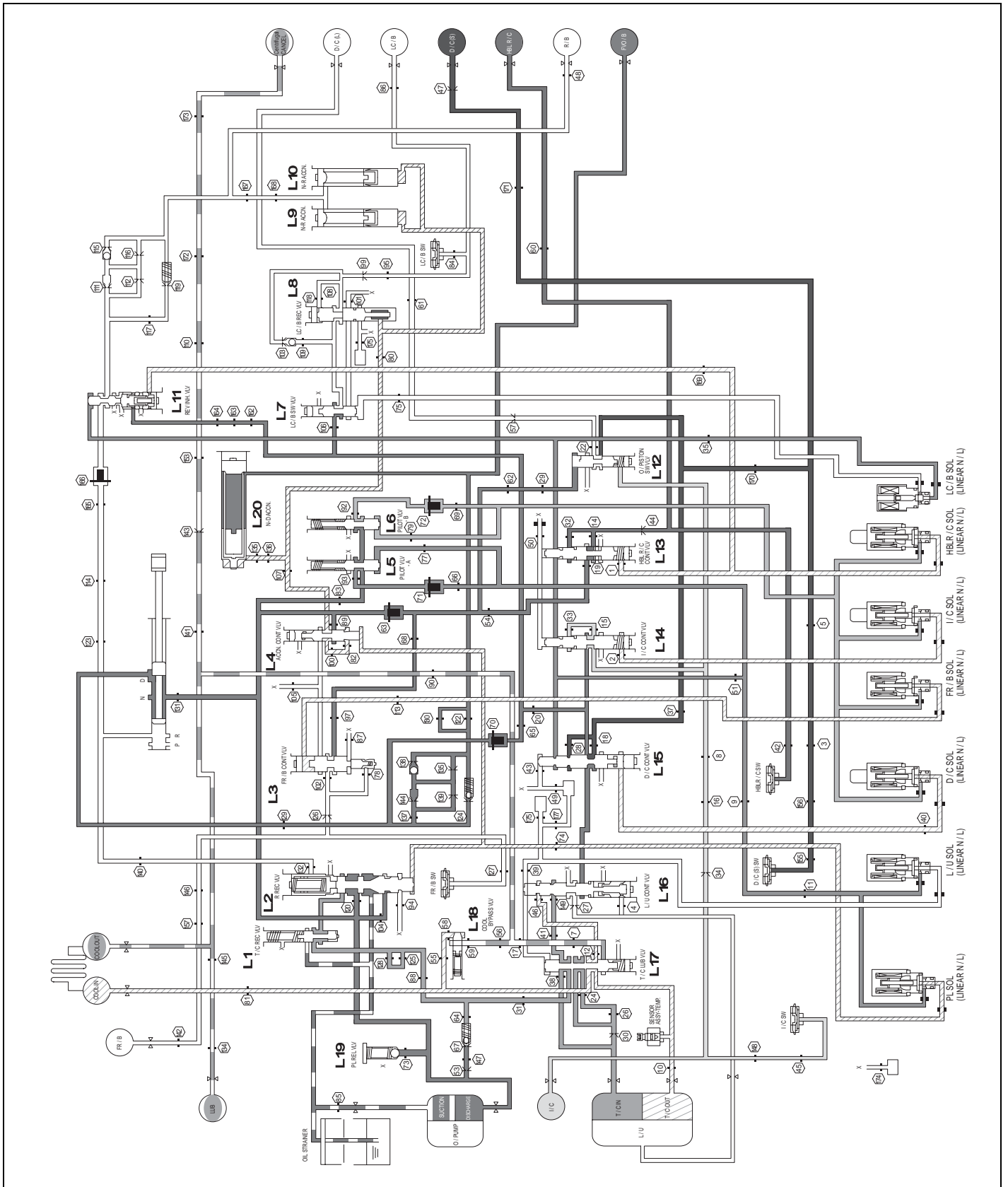

LLAE006E

5TH GEAR (LOCK-UP)

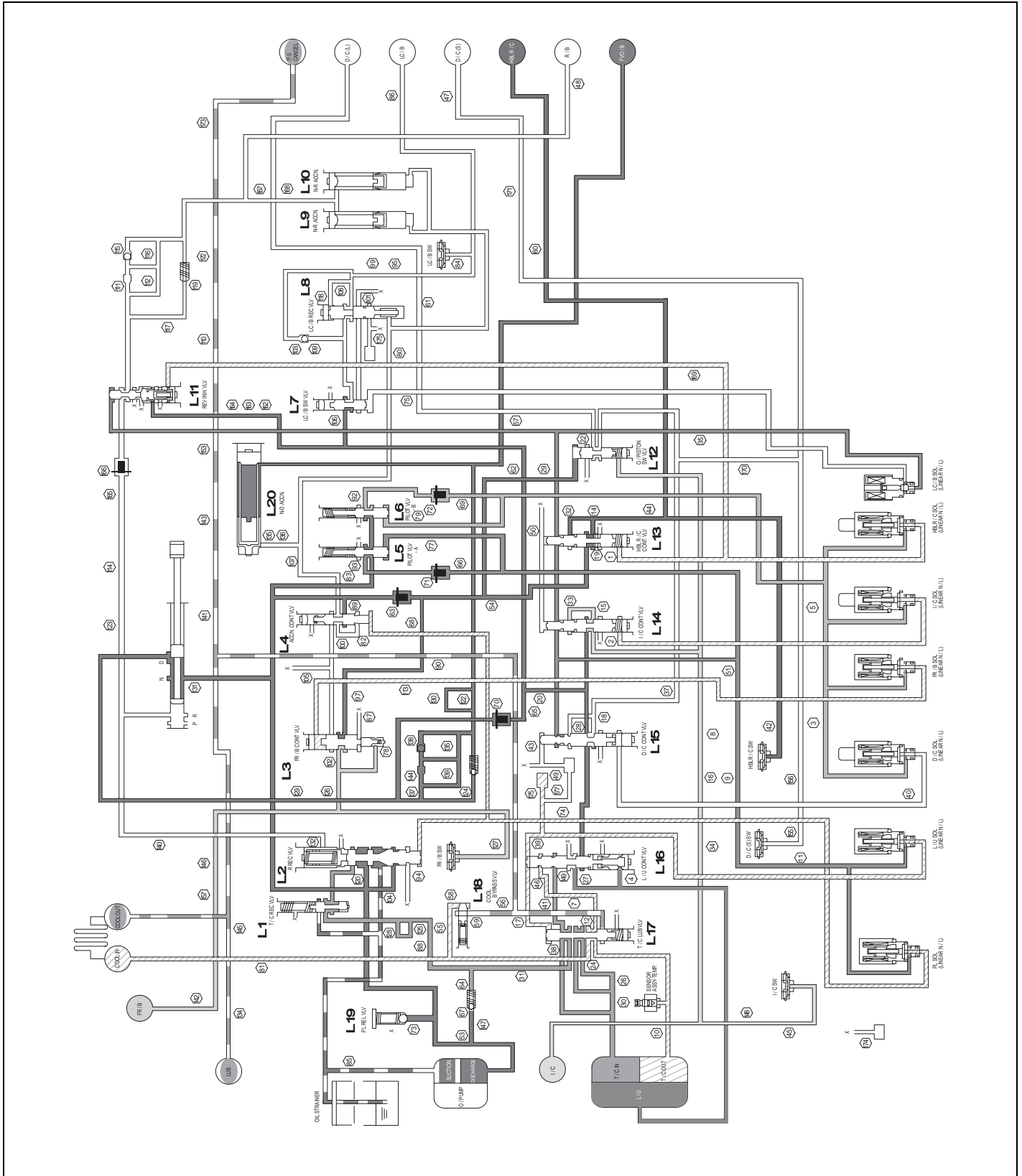

LLAE006F

5TH GEAR

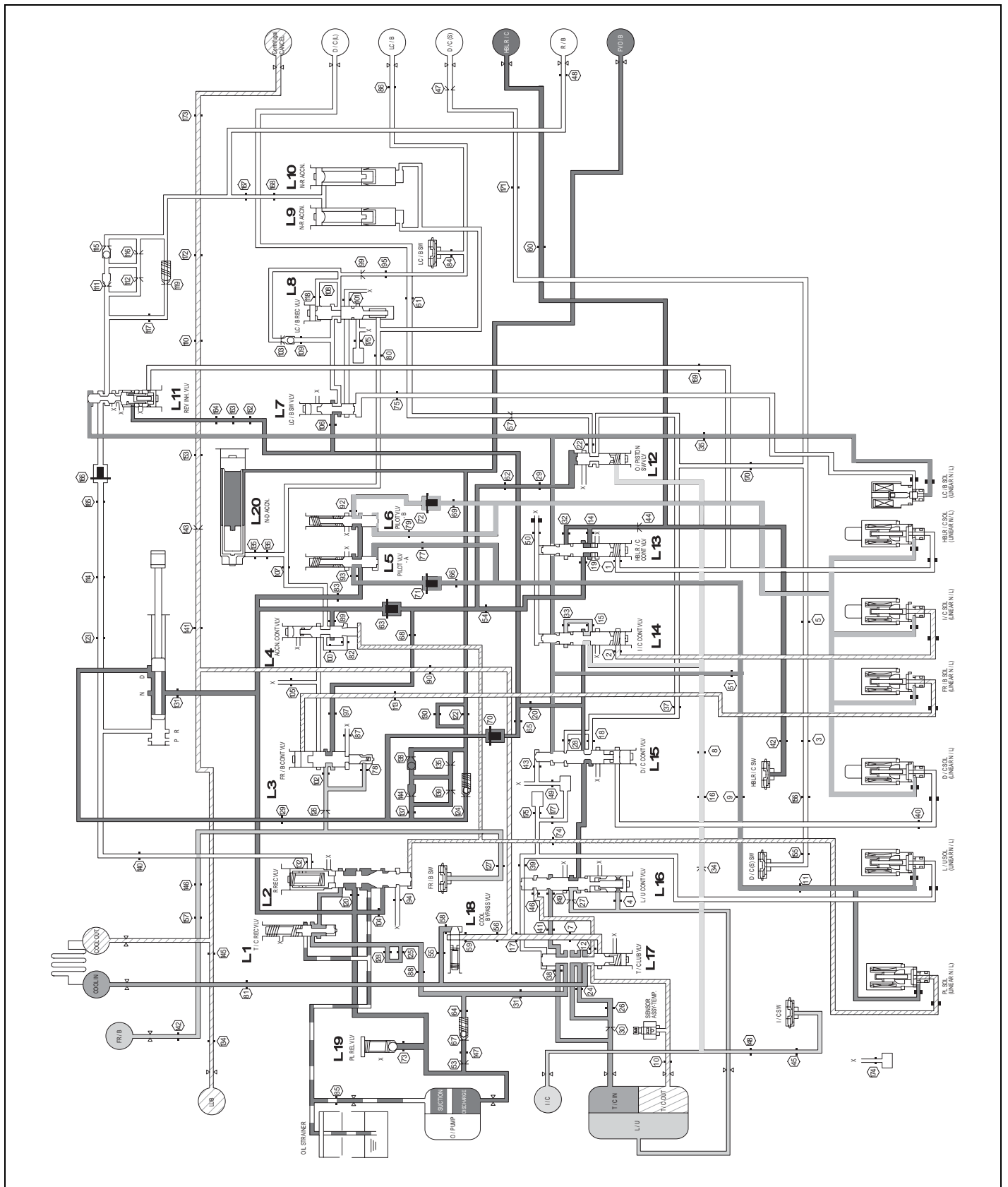

P&N RANGE

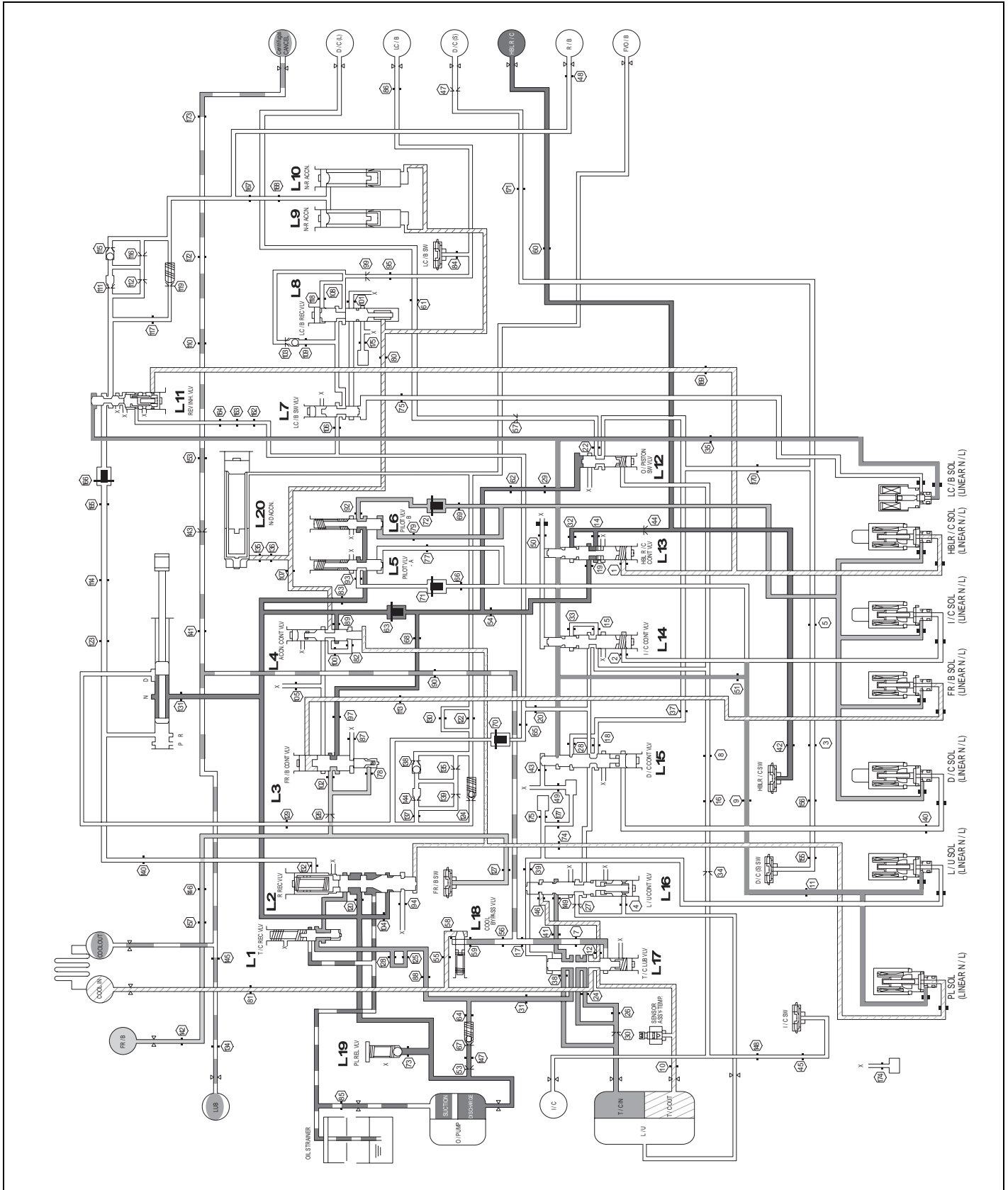

LLAE006H

AUTOMATIC TRANSAXLE SYSTEM

R RANGE

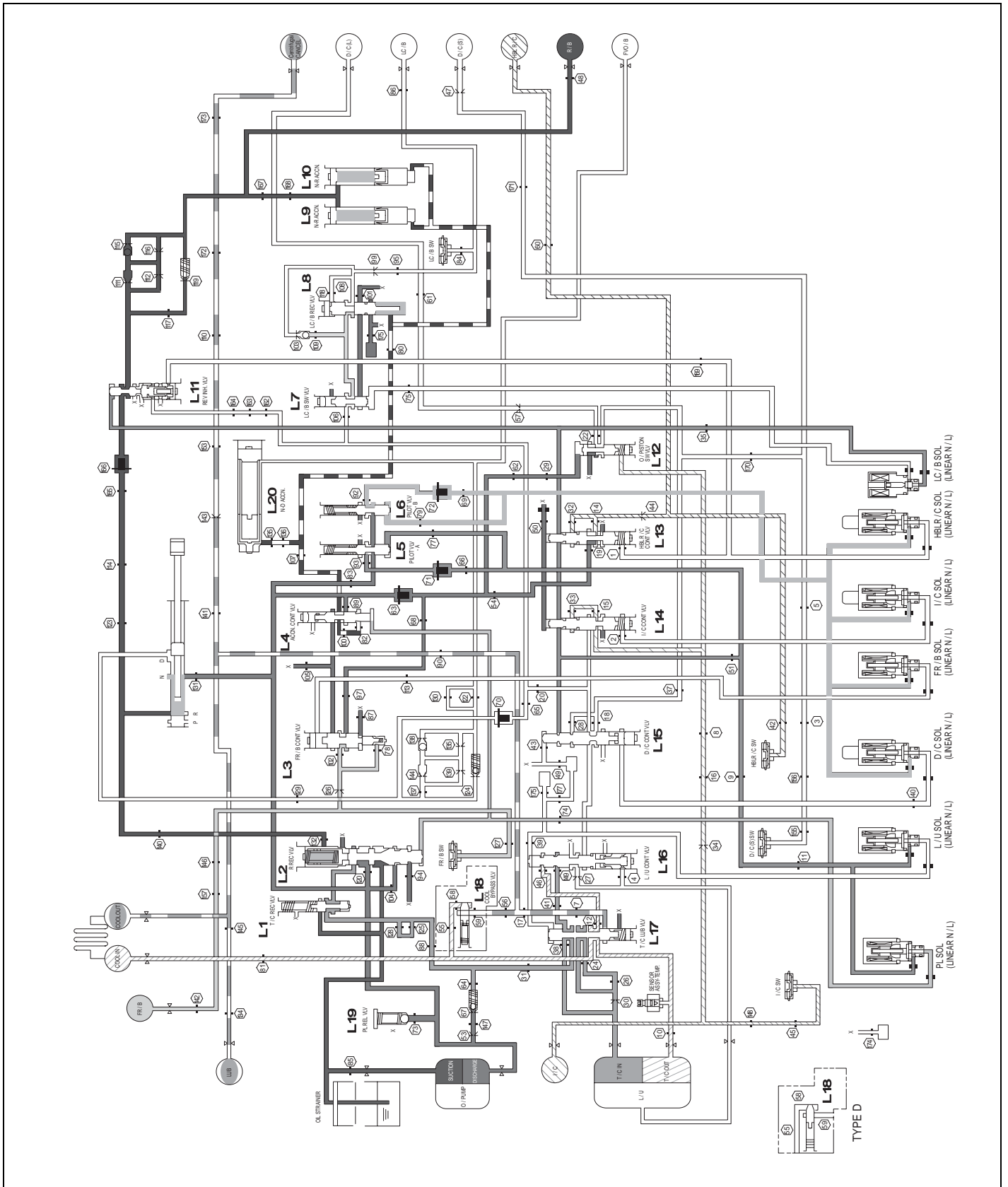

BASIC INSPECTION ADJUSTMENT

EF75F3A9

TRANSAXLE FLUID LEVEL

INSPECTION

1. Drive the vehicle until the fluid reaches normal operating temperature [70~80°C(158~176°F)].
2. Place the vehicle on a level surface.
3. Move the gear selector lever through all gear positions. This will fill the torque converter with trans fluid. Set the selector lever to the "N" (Neutral) position.
4. Before removing the oil level gauge, wipe all contaminants from around the oil level gauge. Then take out the oil level gauge and check the condition of the fluid.

NOTE

If the fluid smells as if it is burning, it means that the fluid has been contaminated by fine particles from the bushes and friction materials, a transmission overhaul may be necessary.

5. Check that the fluid level is in the "HOT" mark on the oil level gauge. If fluid level is low, add automatic transaxle fluid until the level reaches the "HOT" mark.

Automatic transaxle fluid :
APOLLOIL ATF RED-1
ATF capacity: 10 (10.57 US qt, 8.8 Imp.qt)

NOTE

Low fluid level can cause a variety of abnormal conditions because it allows the pump to take in air along with fluid. Air trapped in the hydraulic system forms bubbles, which are compressible. Therefore, pressures will be erratic, causing delayed shifting, slipping clutches and brakes, etc. Improper filling can also raise fluid level too high. When the transaxle has too much fluid, gears churn up foam and cause the same conditions which occur with low fluid level, resulting in accelerated deterioration of automatic transaxle fluid. In either case, air bubbles can cause overheating, and fluid oxidation, which can interfere with normal valve, clutch, and brake operation. Foaming can also result in fluid escaping from the transaxle vent where it may be mistaken for a leak.

6. Insert the oil level gauge securely.

NOTE

When new, automatic transmission fluid should be red, The red dye is added so the assembly plant can identify it as transmission fluid and distinguish it from engine oil or antifreeze. The red dye, which is not an indicator of fluid quality, is not permanent. As the vehicle is driven the transmission fluid will begin to look darker. The color may eventually appear light brown.

REPLACEMENT

If you have a fluid changer, use this changer to replace the fluid. If you do not have a fluid replace the fluid by the following procedure.

1. Disconnect the hose, which connects the transmission and the oil cooler (inside the radiator).
2. Start the engine and let the fluid drain out.

Running conditions : "N" range with engine idling

CAUTION

The engine should be stopped within one minute after it is started. If the fluid has all drained out before then, the engine should be stopped at that point.

3. Remove the drain plug(A) from the bottom of the transmission case to drain the fluid.

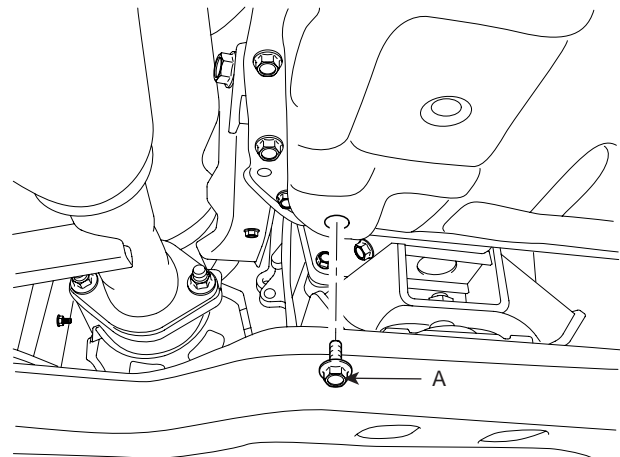

SBLAT6030L

4. Install the drain plug via the gasket, and tighten it the specified torque.

TORQUE:
58.83~63.74Nm (6~6.5kgf.m, 43.39~47.01lb-ft)

5. Pour the new fluid in through the oil filler tube.



CAUTION

Stop pouring if the full volume of fluid cannot be poured in.

6. Repeat the procedure in step (2).



NOTE

Check the old fluid for contamination. If it has been contaminated, repeat the steps (5) and (6).

7. Pour the new fluid in through the oil filler tube.
8. Reconnect the hose, which was disconnected in step (1) above, and firmly replace the oil level gauge. (In case of this "replace", this means after wiping off any dirt around the oil level gauge, insert it into the filler tube.)
9. Start the engine and run it at idle for 1~2 minutes.
10. Move the select lever through all positions, and then move it to the "N" or "P" position.
11. Drive the vehicle until the fluid temperature rises to the normal temperature (70~80°C(158~176°F)), and then check the fluid level again. The fluid level must be at the HOT mark.
12. Firmly insert the oil level gauge into the oil filler tube.

TROUBLESHOOTING E1F24B52

DIAGNOSTIC TROUBLE CODES (INSPECTION PROCEDURE)

Check the Diagnostic Trouble Codes

1. Turn the ignition switch to OFF.
2. Connect the Hi-scan tool to the DLC connector for diagnosis.
3. Turn the ignition switch to ON.
4. Check the diagnostic trouble codes using the Hi-scan tool.
5. Read the output diagnostic trouble codes. Then follow the remedy procedures according to the "DIAGNOSTIC TROUBLE CODE DESCRIPTION" on the following pages.

 **NOTE**

- A maximum of 10 diagnostic trouble codes (in the sequence of occurrence) can be stored in the Random Access Memory (RAM) incorporated within the control module.
- The same diagnostic trouble code can be stored one time only.
- If the number of stored diagnostic trouble codes or diagnostic trouble patterns exceeds 10, already stored diagnostic trouble codes will be erased in sequence, beginning with the oldest.
- Do not disconnect the battery until all diagnostic trouble codes or diagnostic trouble patterns have been read out, because all stored diagnostic trouble codes or diagnostic trouble patterns will be cancelled when the battery is disconnected.
- All diagnostic trouble codes are deleted from memory the 200th time the ATF temperature reaches 50°C (122°F) after memorization of the most recent diagnostic code.

6. Delete the diagnostic trouble code.
7. Disconnect the Hi-scan tool.

 **NOTE**

DTC cleaning should only be done with the scan tool.

AUTOMATIC TRANSAXLE SYSTEM

DIAGNOSTIC TROUBLE CODE TABLE

[DSL 2.5]

No.	Code	Item	MIL	Re- mark
1	P0705	TRANSMISSION RANGE SENSOR CIRCUIT MALFUNCTION (PRND Input)	X	AT-42
2	P0711	TRANSMISSION FLUID TEMPERATURE SENSOR A RATIONALITY		AT-48
3	P0712	TRANSMISSION FLUID TEMPERATURE SENSOR A STUCK OFF(HIGH INPUT)		AT-54
4	P0713	TRANSMISSION FLUID TEMPERATURE SENSOR A STUCK ON(LOW INPUT)		AT-56
5	P0716	A/T INPUT SPEED SENSOR CIRCUIT - OPEN or SHORT(GND)		AT-58
6	P0721	A/T OUTPUT SPEED SENSOR CIRCUIT - OPEN or SHORT(GND)		AT-74
7	P0741	TORQUE CONVERTER CLUTCH STUCK OFF		AT-106
8	P0743	TCC CONTROL SOLENOID VALVE CIRCUIT - OPEN or SHORT(GND)		AT-112
9	P0748	PRESSURE CONTROL SOLENOID VALVE-A CIRCUIT - OPEN or SHORT(GND)		AT-115
10	P0751	SHIFT SOLENOID "A(I/C SOLENOID)" PERPOMANCE OR STUCK OFF		AT-120
11	P0752	SHIFT SOLENOID "A(I/C SOLENOID)" PERPOMANCE OR STUCK ON		AT-125
12	P0753	SHIFT SOLENOID "A(I/C SOLENOID)" CIRCUIT - OPEN or SHORT(GND)		AT-127
13	P0756	SHIFT SOLENOID "B(Fr/B SOLENOID)" PERPOMANCE OR STUCK OFF		AT-132
14	P0757	SHIFT SOLENOID "B(Fr/B SOLENOID)" PERPOMANCE OR STUCK ON		AT-137
15	P0758	SHIFT SOLENOID "B(Fr/B SOLENOID)" CIRCUIT - OPEN or SHORT(GND)	X	AT-139
16	P0761	SHIFT SOLENOID "C(D/C SOLENOID)" PERPOMANCE OR STUCK OFF	X	AT-144
17	P0762	SHIFT SOLENOID "C(D/C SOLENOID)" PERPOMANCE OR STUCK ON	X	AT-149
18	P0763	SHIFT SOLENOID "C(D/C SOLENOID)" CIRCUIT - OPEN or SHORT(GND)	X	AT-151
19	P0766	SHIFT SOLENOID "D(H & LR/C SOLENOID)" PERPOMANCE OR STUCK OFF	X	AT-156
20	P0767	SHIFT SOLENOID "D(H & LR/C SOLENOID)" PERPOMANCE OR STUCK ON		AT-161
21	P0768	SHIFT SOLENOID "D(H & LR/C SOLENOID)" CIRCUIT - OPEN or SHORT(GND)		AT-163
22	P0772	SHIFT SOLENOID "E(LC/B SOLENOID)" PERPOMANCE OR STUCK OFF		AT-168
23	P0773	SHIFT SOLENOID "E(LC/B SOLENOID)" CIRCUIT - OPEN or SHORT(GND)		AT-172
24	P0863	CAN COMMUNICATION BUS OFF		AT-182
25	P0893	MULTIPLE GEARS ENGAGED		AT-186

[GSL 3.3/3.8]

No.	Code	Item	MIL	Re-mark
1	P0601	INTERNAL CONTROL MODULE MEMORY CHECK SUM ERROR		AT-37
2	P0641	SENSOR REFERENCE VOLTAGE "A" CIRCUIT - OPEN		AT-39
3	P0705	TRANSMISSION RANGE SENSOR CIRCUIT MALFUNCTION (PRND Input)		AT-42
4	P0711	TRANSMISSION FLUID TEMPERATURE SENSOR A RATIONALITY		AT-48
5	P0712	TRANSMISSION FLUID TEMPERATURE SENSOR A STUCK OFF(HIGH INPUT)		AT-54
6	P0713	TRANSMISSION FLUID TEMPERATURE SENSOR A STUCK ON(LOW INPUT)		AT-56
7	P0716	A/T INPUT SPEED SENSOR CIRCUIT - OPEN or SHORT(GND)		AT-58
8	P0717	A/T INPUT SPEED SENSOR CIRCUIT - NO SIGNAL		AT-66
9	P0721	A/T OUTPUT SPEED SENSOR CIRCUIT - OPEN or SHORT(GND)		AT-74
10	P0731	GEAR 1 INCORRECT RATIO		AT-82
11	P0732	GEAR 2 INCORRECT RATIO		AT-88
12	P0733	GEAR 3 INCORRECT RATIO		AT-93
13	P0734	GEAR 4 INCORRECT RATIO		AT-97
14	P0735	GEAR 5 INCORRECT RATIO		AT-102
15	P0741	TORQUE CONVERTER CLUTCH STUCK OFF		AT-106
16	P0743	TCC CONTROL SOLENOID VALVE CIRCUIT - OPEN or SHORT(GND)		AT-112
17	P0748	PRESSURE CONTROL SOLENOID VALVE-A CIRCUIT - OPEN or SHORT(GND)		AT-115
18	P0753	SHIFT SOLENOID "A(I/C SOLENOID)" CIRCUIT - OPEN or SHORT(GND)		AT-127
19	P0758	SHIFT SOLENOID "B(Fr/B SOLENOID)" CIRCUIT - OPEN or SHORT(GND)		AT-139
20	P0763	SHIFT SOLENOID "C(D/C SOLENOID)" CIRCUIT - OPEN or SHORT(GND)		AT-151
21	P0768	SHIFT SOLENOID "D(H&LR/C SOLENOID)" CIRCUIT - OPEN or SHORT(GND)		AT-163
22	P0773	SHIFT SOLENOID "E(LC/B SOLENOID)" CIRCUIT - OPEN or SHORT(GND)		AT-172
23	P0819	UP AND DOWN SHIFT SWITCH TO TRANSMISSION RANGE CORRELATION	X	AT-176
24	U0001	CAN COMMUNICATION BUS		AT-190
25	U0100	LOST COMMUNICATION WITH PCM "A"		AT-194

DTC P0601 EEPROM-CHECK SUM ERROR

COMPONENT LOCATION EA71F251

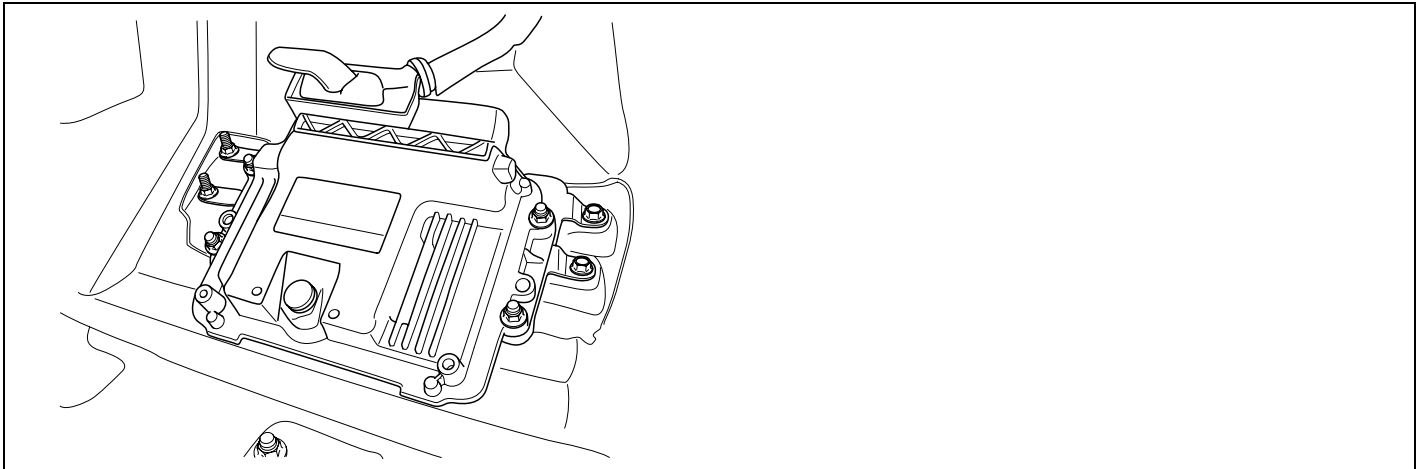

SBLAT6200L

GENERAL DESCRIPTION EFF06479

The TCU check ROM I.D all the time, in order to maintain for best condition and surrounding.

DTC DESCRIPTION E239491D

The TCU set this code when the ROM I.D is changed by external force or input non-available data.

DTC DETECTING CONDITION EC25D0F8

Item	Detecting Condition	Possible cause
DTC Strategy	<ul style="list-style-type: none">• Check sum fault	<ul style="list-style-type: none">• Faulty TCM
Enable Conditions	<ul style="list-style-type: none">• IG "on"	
Threshold value	<ul style="list-style-type: none">• Checksum fault or TCU internal Failure	
Diagnostic Time	<ul style="list-style-type: none">• More than 1sec	
Fail Safe	<ul style="list-style-type: none">• Locked in 3rd gear	

MONITOR SCANTOOL DATA E28D4FFB

1. Connect scantool to data link connector(DLC).
2. Ignition "ON".
3. Confirm the "ROM I.D".
4. Perform the "ROM UP-DATE".
5. Perform the Re-diagnosis
6. Is "DTC" disappeared?

YES

Fault is intermittent caused by poor contact in the sensor's and/or PCM/TCM's connector or was repaired and PCM/TCM memory was not cleared. Thoroughly check connectors for looseness, poor connection, bending, corrosion, contamination, deterioration or damage. Repair or replace as necessary and go to "Verification of Vehicle Repair" procedure.

NO

Replace PCM/TCM as necessary and then go to "Verification of Vehicle Repair" procedure.

VERIFICATION OF VEHICLE REPAIR E41990B1

After a repair, it is essential to verify that the fault has been corrected.

1. Connect scantool and select "Diagnostic Trouble Codes(DTCs)" mode.
2. Using a scantool, Clear DTC.
3. Operate the vehicle within DTC Enable conditions in General information.
4. Are any DTCs present?

YES

Go to the applicable troubleshooting procedure.

NO

System performing to specification at this time.

DTC P0641 SENSOR REFERENCE VOLTAGE "A" CIRCUIT OPEN

COMPONENT LOCATION EEE7C17

Refer to DTC P0601.

GENERAL DESCRIPTION E4A2D7DF

The TCM monitors voltage that supplied to solenoid valve.

DTC DESCRIPTION EE53B1A

The TCM sets this code when supplying voltage to TCM is lower or higher than specification.

DTC DETECTING CONDITION EE53B1A

Item	Detecting Condition	Possible cause
DTC Strategy	<ul style="list-style-type: none">• Check voltage range	<ul style="list-style-type: none">• Faulty TCM
Enable Conditions	<ul style="list-style-type: none">• Battery voltage > 11.7V	
Threshold value	<ul style="list-style-type: none">• 10.4V < Sensor supply voltage > 16V	
Diagnostic Time	<ul style="list-style-type: none">• More than 0.2sec	
Fail Safe	<ul style="list-style-type: none">• Damper clutch "OFF"• Prevention of pressure adaptation	

MONITOR SCANTOOL DATA E44BB402

1. Connect scantool to data link connector(DLC).
2. Ignition "ON" & Engine "OFF".
3. Monitor the "BATTERY VOLTAGE and A/T MAIN RELAY VOLTAGE" parameter on the scantool.

Specification : approx. 12V

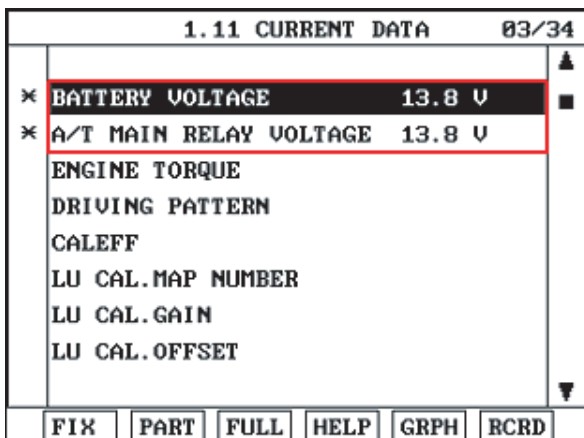

4. Does "BATTERY VOLTAGE and A/T MAIN RELAY VOLTAGE" follow the reference data?

YES

Fault is intermittent caused by poor contact in the sensor's and/or PCM/TCM's connector or was repaired and PCM/TCM memory was not cleared. Thoroughly check connectors for looseness, poor connection, bending, corrosion, contamination, deterioration or damage. Repair or replace as necessary and go to "Verification of Vehicle Repair" procedure.

NO

Go to "Terminal & connector inspection" procedure.

TERMINAL & CONNECTOR INSPECTION ECBDE7AB

- 1. Many malfunctions in the electrical system are caused by poor harness and terminals. Faults can also be caused by interference from other electrical systems, and mechanical or chemical damage.
- 2. Thoroughly check connectors for looseness, poor connection, bending, corrosion, contamination, deterioration, or damage.
- 3. Has a problem been found?

YES

Repair as necessary and go to "Verification of vehicle Repair" procedure.

NO

Go to "Power supply circuit inspection" procedure.

POWER SUPPLY CIRCUIT INSPECTION E5402EEB

- 1. IG "ON" Engine "OFF".
- 2. Disconnect the "PCM/TCM" connector.
- 3. Measure voltage between terminal No"29" of TCM harness connector and chassis ground and then terminal No"73" of the TCM harness connector and chassis ground.

Specification : approx. 12V

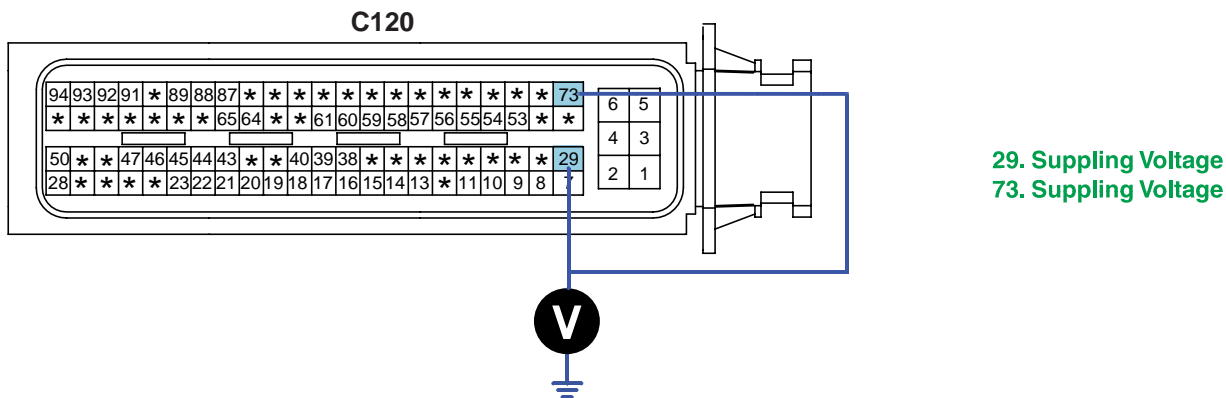

4. Is voltage within specifications?

YES

Fault is intermittent caused by poor contact in the sensor's and/or PCM/TCM's connector or was repaired and PCM/TCM memory was not cleared. And go to Verification of Vehicle Repair procedure.

NO

Substitute with a known-good PCM/TCM and check for proper operation. If the problem is corrected, replace PCM/TCM as necessary and then go to "Verification of Vehicle Repair" procedure.

VERIFICATION OF VEHICLE REPAIR E9BF9C0F

Refer to DTC P0601.

DTC P0705 TRANSAXLE RANGE SWITCH (TR SWITCH)

COMPONENT LOCATION E505DFFD

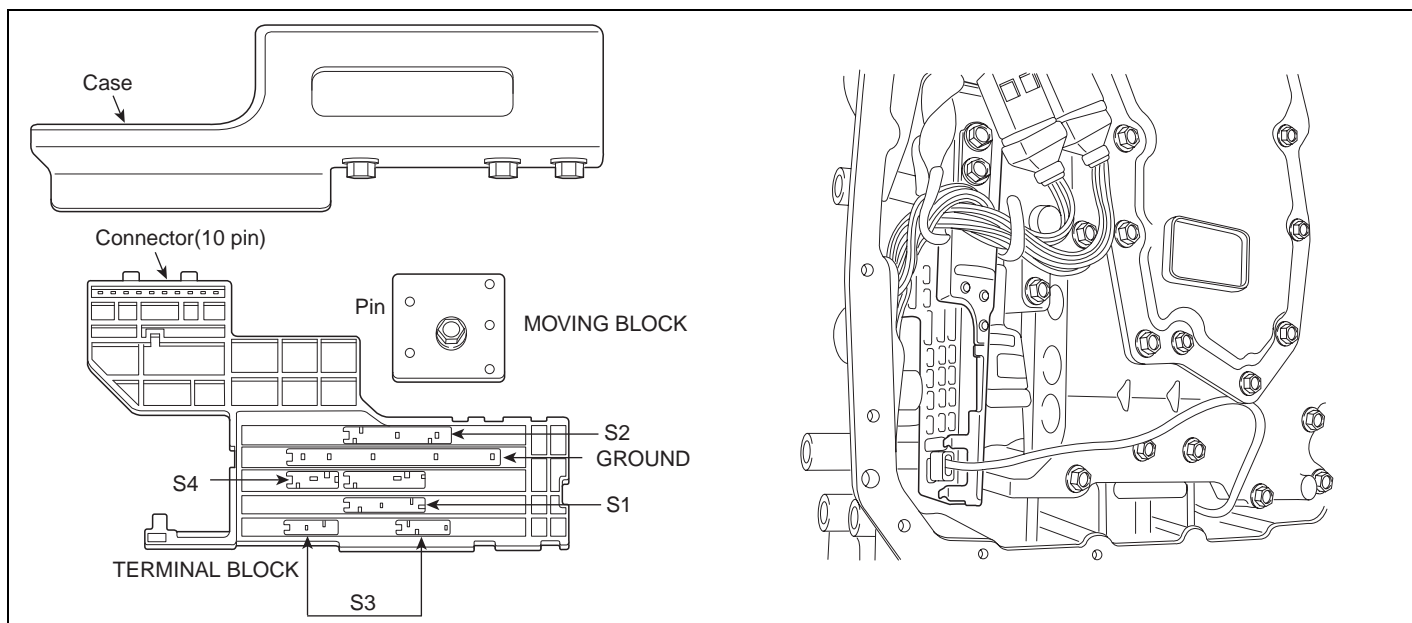

SBLAT6100L

GENERAL DESCRIPTION E37B66E4

The TRANSMISSION Range Switch sends the shift lever position information to the TCM using a 5V signal. Deciding each TCM range depend on 4 s/w signal. Standard patterns are fixed and these patterns are on the Specification table as listed below. For example, when s/w 1,2,4 are 'ON(0V)' and s/w 3 is 'OFF(5V)', TCM recognizes 'D Range'. When the shift lever is in the D (Drive) position the output signal of Tansaxle Range Switch is 12V and in all other positions the voltage is 0V. The TCM judges the shift lever position by reading all signals, for the TRANSMISSION Range Switch, simultaneously.

DTC DESCRIPTION EDB095D4

The TCM sets this code when patterns are without Specification of the table shown below. The TRANSMISSION Range Switch has no output signal for an extended period of time.

AUTOMATIC TRANSAXLE SYSTEM

DTC DETECTING CONDITION EBEC8AEB

[DSL 2.5]

Item	Detecting Condition	Possible cause
DTC Strategy	<ul style="list-style-type: none"> Range decision by switch pattern 	<ul style="list-style-type: none"> OPEN OR SHORT IN CIRCUIT Faulty TRANSMISSION RANGE SWITCH Faulty TCM
Enable Conditions	<ul style="list-style-type: none"> Vehicle speed 10km/h[6.2MPH] Throttle opening 12.5% 	
Threshold value	<ul style="list-style-type: none"> Detect irregular range pattern (REFER TO SPECIFICATION) 	
Diagnostic Time	<ul style="list-style-type: none"> More than 2sec 	
Fail Safe	<ul style="list-style-type: none"> SELECT POSITION IS REGARDED AS "D" INDICATOR DECISION "OFF" START RERAY SIGNAL "OFF" REVERSE LAMP SIGNAL "OFF" 	

[GSL 3.3/3.8]

Item	Detecting Condition	Possible cause
DTC Strategy	<ul style="list-style-type: none"> Range decision by switch pattern 	<ul style="list-style-type: none"> OPEN OR SHORT IN CIRCUIT Faulty TRANSMISSION RANGE SWITCH Faulty TCM
Enable Conditions	<ul style="list-style-type: none"> Always 	
Threshold value	<ul style="list-style-type: none"> "INHIBITOR SWITCH" pattern check. 	
Diagnostic Time	<ul style="list-style-type: none"> More than 10sec 	
Fail Safe	<ul style="list-style-type: none"> SELECT POSITION IS REGARDED AS "D" INDICATOR DECISION "OFF" REVERSE LAMP SIGNAL "OFF" 	

SPECIFICATION EE4C763C

A/T RANGE PATTERN

A/T range switch				Range swsitch	Remarks
SW1	SW2	SW3	SW4		
OFF	OFF	OFF	OFF	Pst	P start
OFF	OFF	ON	OFF	P	P
OFF	OFF	ON	ON	P-R	Intermediate
ON	OFF	ON	ON	R	R
ON	OFF	ON	OFF	N-R	Intermediate
ON	OFF	OFF	OFF	Nst	N start
ON	OFF	OFF	ON	N-D	Intermediate
ON	ON	OFF	ON	D	D
OFF	ON	OFF	ON	3	3
OFF	ON	ON	ON	2	2
OFF	ON	ON	OFF	1	1
Irregular Pattern				Other	

[OFF= 5V, ON = 0V]

MONITOR SCANTOOL DATA

EF6B38A6

1. Connect scantool to data link connector(DLC).
2. Ignition "ON" & Engine "OFF".
3. Monitor the "TRANSMISSION RANGE SWITCH" parameter on the scantool.
4. Move selector lever from "P" range to "D" range.

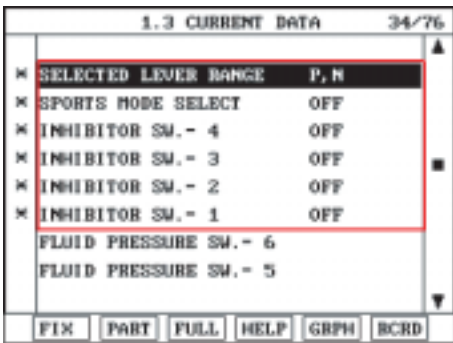

FIG.1)

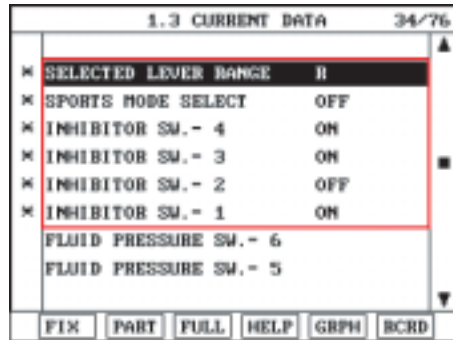

FIG.2)

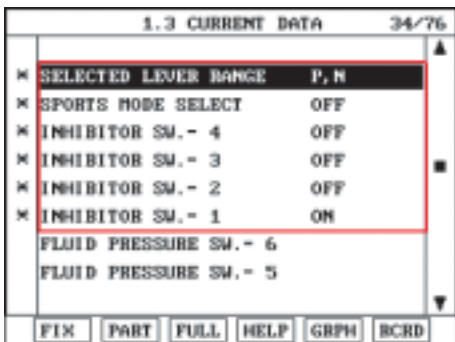

FIG.3)

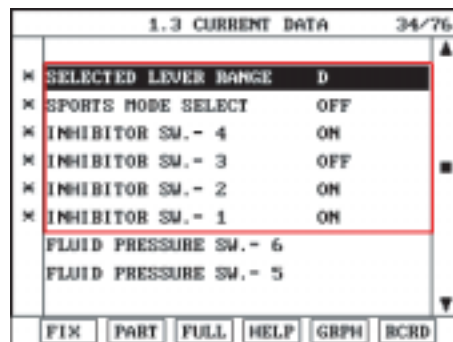

FIG.4)

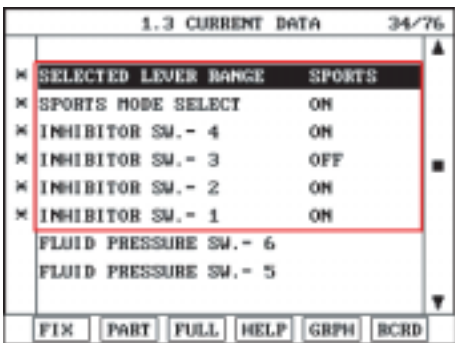

FIG.5)

- FIG.1) P RANGE
- FIG.2) R RANGE
- FIG.3) N RANGE
- FIG.4) D RANGE
- FIG.5) SPORTS MODE

AUTOMATIC TRANSAXLE SYSTEM

AT -45

5. Does "TRANSMISSION RANGE SWITCH" follow the reference data?

YES

Fault is intermittent caused by poor contact in the sensor's and/or PCM/TCM's connector or was repaired and PCM/TCM memory was not cleared. Thoroughly check connectors for looseness, poor connection, bending, corrosion, contamination, deterioration or damage. Repair or replace as necessary and go to "Verification of Vehicle Repair" procedure.

NO

Go to "Terminal & connector inspection" procedure.

TERMINAL & CONNECTOR INSPECTION EDDEB23B

1. Many malfunctions in the electrical system are caused by poor harness and terminals. Faults can also be caused by interference from other electrical systems, and mechanical or chemical damage.
2. Thoroughly check connectors for looseness, poor connection, bending, corrosion, contamination, deterioration, or damage.
3. Has a problem been found?

YES

Repair as necessary and go to "Verification of vehicle Repair" procedure.

NO

Go to "Signal circuit inspection" procedure.

SIGNAL CIRCUIT INSPECTION E2A878C4

1. Disconnect "C06-3/C106-3" connector.
2. Ignition "ON" & Engine "OFF".
3. Measure voltage between each terminal "1,2,3,4" of the TCM side harness connector and chassis ground.

Specification : approx. 5V

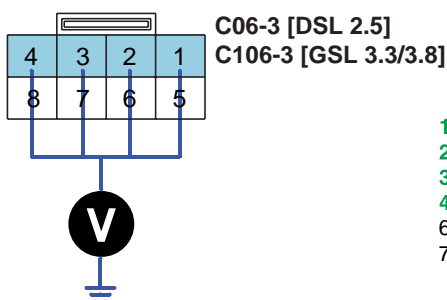

SBLAT6102L

4. Is voltage within specifications?

YES

Go to "Component inspection" procedure.

NO

Check for open or short in harness. Repair as necessary and Go to "Verification of Vehicle Repair" procedure. If signal circuit in harness is OK, Substitute with a known-good PCM/TCM and check for proper operation. If the problem is corrected, replace PCM/TCM as necessary and go to "Verification of Vehicle Repair" procedure.

COMPONENT INSPECTION EE64569B

1. Ignition "OFF".
2. Disconnect "C06-3/C106-3" connector.
3. Measure the resistance between each terminal of the sensor.

Specification :

PIN No.	GND	1(S1)	2(S2)	3(S3)	4(S4)	IND
P-ST	●					P
P-R(middle)	●				●	-
R	●	●		●	●	R
N-R(middle)	●	●	●		●	-
N-ST	●	●				N
N-D(middle)	●	●	●	●		-
D	●	●	●		●	D

● : SWITCH IS ON(GND LEVER)
 - : RANGE INDICATER LAMP "OFF" AND MAINTAIN PREVIOUS RANGE

[RANGE SWITCH continuity check table]

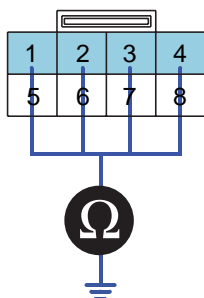

C06-3 [DSL 2.5]
 C106-3 [GSL 3.3/3.8]
 Component side

1. TRANSMISSION RANGE SWITCH SW1
2. TRANSMISSION RANGE SWITCH SW2
3. TRANSMISSION RANGE SWITCH SW3
4. TRANSMISSION RANGE SWITCH SW4
6. TURBINE SENSOR 1
7. TURBINE SENSOR 2

4. Is resistance within specifications?

YES

Thoroughly check connectors for looseness, poor connection, bending, corrosion, contamination, deterioration, or damage. Repair or replace as necessary and then go to "Verification of Vehicle Repair" procedure.

NO

Check for open or short in harness. Repair as necessary and Go to "Verification of Vehicle Repair" procedure. If signal circuit in harness is OK, Substitute with a known-good "TRANSMISSION RANGE SWITCH" and check for proper operation. If the problem is corrected, replace "TRANSMISSION RANGE SWITCH" as necessary and go to "Verification of Vehicle Repair" procedure.

VERIFICATION OF VEHICLE REPAIR E53F1BDD

After a repair, it is essential to verify that the fault has been corrected.

1. Connect scantool and select "Diagnostic Trouble Codes(DTCs)" mode.
2. Using a scantool, Clear DTC.
3. Operate the vehicle within DTC Enable conditions in General information.
4. Are any DTCs present?

YES

Go to the applicable troubleshooting procedure.

NO

System performing to specification at this time.

DTC P0711 TRANSAXLE FLUID TEMPERATURE SENSOR RATIONALITY

COMPONENT LOCATION EE2FDAD9

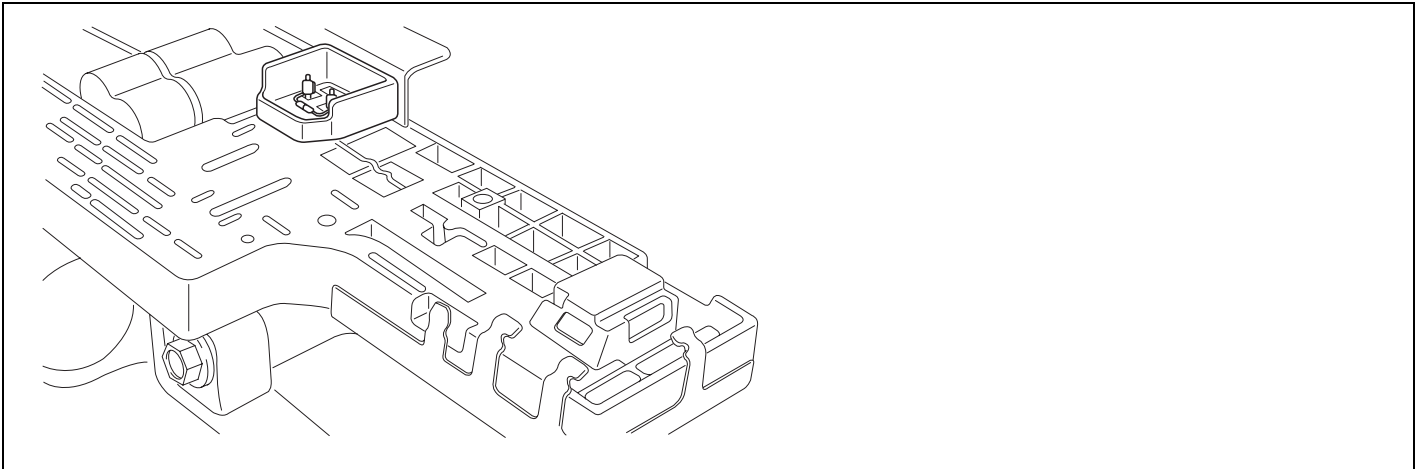

SBLAT6110L

GENERAL DESCRIPTION E71EE02E

The automatic transmission fluid(ATF) temperature sensor A is installed in the INHIBITOR SWITCH and fluid(ATF) temperature sensor B is installed in the valve body. Sensor "B" is measure the oil temperature that inflowed in from Torque convertor. This sensors use a thermistor whose resistance changes according to the temperature changes. The TCM supplies a 5V reference voltage to the sensor, and the output voltage of the sensor changes when the ATF temperature varies. The automatic transmission fluid(ATF) temperature provides very important data for the TCM's control of the Torque Converter Clutch, and is also used for many other purposes.

DTC DESCRIPTION EA59CCAF

This DTC is for checking sensor failure. This code is set if the temperture data from Oil Temperture sensor is fixed between -4°F and 32°F or 32°F and 68°F for 10min. after driving a behicle.

AUTOMATIC TRANSAXLE SYSTEM

DTC DETECTING CONDITION EFEB37C

[DSL 2.5]

Item	Detecting Condition	Possible cause
DTC Strategy	<ul style="list-style-type: none"> Fluctuation of A/T fluid temperature 	ATF T/S : Automatic Transmission Fluid Temperature Sensor <ul style="list-style-type: none"> OPEN OR SHORT IN CIRCUIT Faulty ATF T/S 1 Faulty TCM
Enable Conditions	<ul style="list-style-type: none"> A/T range switch is D range Vehicle speed 6.2MPH(10km/h) Throttle opening 12.5% Engine speed 305rpm 	
Threshold value	<ul style="list-style-type: none"> -4°F A/T fluid temperature < 32°F for cumulative total of 10 minutes or 32°F A/T fluid temperature < 68°F for cumulative total of 10 minutes(refer fig.2 Diagnostic logic for ATF temp. sensor) 	
Diagnostic Time	<ul style="list-style-type: none"> 10minutes accumulative total 	
Fail Safe	<ul style="list-style-type: none"> S-MODE is Inhibited 5th gear is Inhibite 	

[GSL 3.3/3.8]

Item	Detecting Condition	Possible cause
DTC Strategy	<ul style="list-style-type: none"> Rationality 	ATF T/S : Automatic Transmission Fluid Temperature Sensor <ul style="list-style-type: none"> OPEN OR SHORT IN CIRCUIT Faulty ATF T/S 1 Faulty TCM
Enable Conditions	<ul style="list-style-type: none"> Always 	
Threshold value	<ul style="list-style-type: none"> Oil temp. at IG "ON" - Coolant temp. at IG "ON" > 10°C 	
Diagnostic Time	<ul style="list-style-type: none"> More than 2 sec 	
Fail Safe	<ul style="list-style-type: none"> Fluid temperature is regarded as 80°C 	

SPECIFICATION E42BB6FD

	PIN No	TEMPERATURE (°F)	RESISTANCE (K)	VOLTAGE (V)
ATF 1	C06-1/C106-1 : 9 ~ Earth	32	Approx. 15	Approx. 3.3
		68	Approx. 6.5	Approx. 2.7
		176	Approx. 0.9	Approx. 0.9
ATF 2	C06-2/C106-2 : 1 ~ Earth	32	Approx. 10.5	Approx. 3.3
		68	Approx. 4.3	Approx. 2.5
		176	Approx. 0.5	Approx. 0.7

MONITOR SCANTOOL DATA EEF3D5D0

1. Connect scantool to data link connector(DLC).
2. Engine "ON".
3. Monitor the "TRANSAXLE FLUID TEMPERATURE SENSOR "1" parameter on the scantool.

Specification : Increasing Gradually

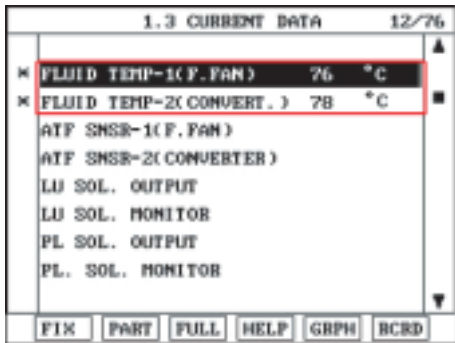

FIG.1)

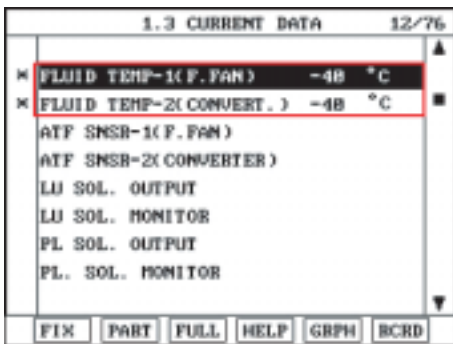

FIG.2)

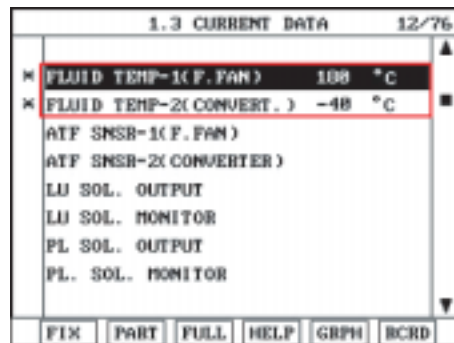

FIG.3)

FIG.1) Normal

FIG.2) Signal harness open

FIG.3) Signal harness ground short

SBLAT6111L

4. Does "TRANSMISSION FLUID TEMPERATURE SENSOR " follow the reference data?

YES

Fault is intermittent caused by poor contact in the sensor's and/or PCM/TCM's connector or was repaired and PCM/TCM memory was not cleared. Thoroughly check connectors for looseness, poor connection, bending, corrosion, contamination, deterioration or damage. Repair or replace as necessary and go to "Verification of Vehicle Repair" procedure.

NO

Go to "Terminal & connector inspection" procedure.

TERMINAL & CONNECTOR INSPECTION EEB04194

1. Many malfunctions in the electrical system are caused by poor harness and terminals. Faults can also be caused by interference from other electrical systems, and mechanical or chemical damage.
2. Thoroughly check connectors for looseness, poor connection, bending, corrosion, contamination, deterioration, or damage.
3. Has a problem been found?

YES

Repair as necessary and go to "Verification of vehicle Repair" procedure.

NO

Go to "Signal circuit inspection" procedure.

SIGNAL CIRCUIT INSPECTION EF9D4BA0

1. Ignition "ON" & Engine "OFF".
2. Disconnect the "ATF 1[C06-1/C106-1] and ATF 2[C06-2/C106-2]" connector.
3. Measure the voltage between terminal "9" of the "ATF 1 [C06-1/C106-1]" harness connector and chassis ground.

Specification : Approx. 5 V

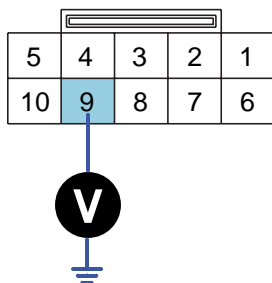

**C06-1 [DSL 2.5]
C106-1 [GSL 3.3/3.8]**

- 1.VIGN-OUT 1
- 2.DATA BIT 1
- 3.PSB 2
- 4.PSC 2
- 5.SEL 1
- 6.SEL 2
- 7.SEL 3
- 8.GND
- 9.ATF 1**
- 10.VSP 1

SBLAT6112L

4. Is voltage within specifications?

YES

Go to "Component Inspection" procedure.

NO

Check for open or short in harness. Repair as necessary and Go to "Verification of Vehicle Repair" procedure. If signal circuit in harness is OK, Go to "CHECK TCM" of the "Component Inspection" procedure.

COMPONENT INSPECTION E41CBBC3

1. CHECK "TRANSMISSION FLUID TEMPERATURE SENSOR"

- 1) Ignition "OFF" .
- 2) Disconnect the "ATF 1 [C06-1/C106-1] and ATF 2 [C06-2/C106-2]" connector.
- 3) Measure the rasistance between terminal "9" of the "ATF 1 [C06-1/C106-1]" harness connector and chassis ground.

Specification : Refer to " Reference data"

[REFERENCE DATA]

	PIN No	TEMPERATURE (°F)	RESISTANCE (K)	VOLTAGE (V)
ATF 1	C06-1/C106-1 : 9 ~ Earth	32	Approx. 15	Approx. 3.3
		68	Approx. 6.5	Approx. 2.7
		176	Approx. 0.9	Approx. 0.9
ATF 2	C06-2/C106-2 : 1 ~ Earth	32	Approx. 10.5	Approx. 3.3
		68	Approx. 4.3	Approx. 2.5
		176	Approx. 0.5	Approx. 0.7

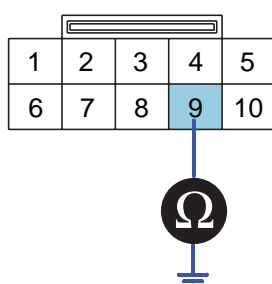

C06-1 [DSL 2.5]
C106-1 [GSL 3.3/3.8]
Component side

- 1.VIGN-OUT 1
- 2.DATA BIT 1
- 3.PSB 2
- 4.PSC 2
- 5.SEL 1
- 6.SEL 2
- 7.SEL 3
- 8.GND
- 9.ATF 1
- 10.VSP 1

SBLAT6113L

- 4) Is resistance within specifications?

YES

Go to "CHECK PCM/TCM" as below.

NO

Check for open or short in harness. Repair as necessary and Go to "Verification of Vehicle Repair" procedure. Replace "TRANSMISSION FLUID TEMPERATURE SENSOR 1" as necessary and Go to "Verification of Vehicle Repair" procedure.

2. CHECK TCM

- 1) Ignition "ON" & Engine "OFF".
- 2) Disconnect the "ATF 1 [C06-1/C106-1] " connector.
- 3) Install scantool and select a SIMU-SCAN.
- 4) Simulate voltage (0 5V) to "TRANSMISSION FLUID TEMPERATURE SENSOR 1, 2" signal circuit.

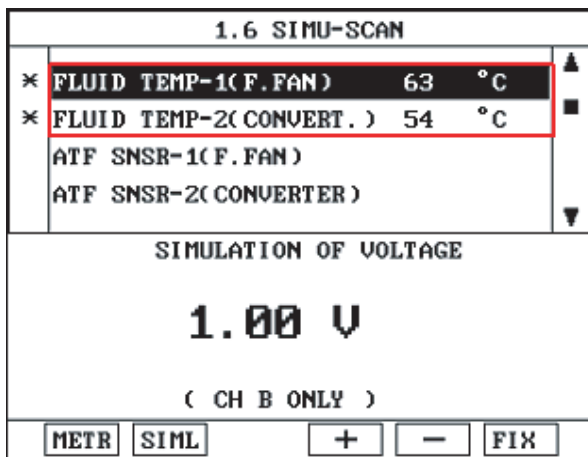

FIG.1)

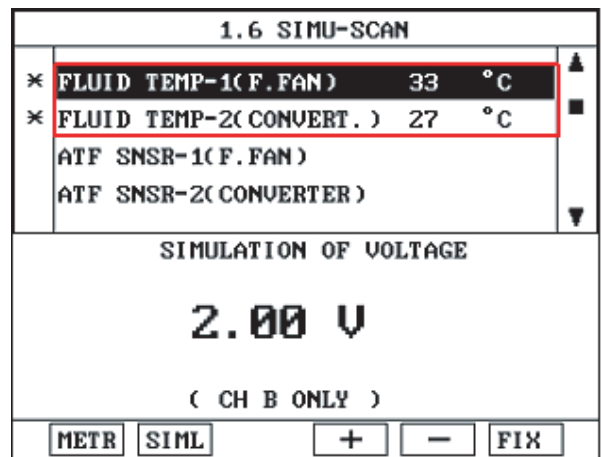

FIG.2)

FIG.1) INPUT 1.02V → 63°C
FIG.2) INPUT 2.00V → 33°C

※ The values are subject to change according to vehicle model or conditions.

SBLAT6114L

5) Is FLUID TEMP. SENSOR signal value changed according to simulation voltage?

YES

Thoroughly check connectors for looseness, poor connection, bending, corrosion, contamination, deterioration, or damage. Repair or replace as necessary and then go to "Verification of Vehicle Repair" procedure.

NO

Substitute with a known-good TCM and check for proper operation. If the problem is corrected, replace TCM as necessary and go to "Verification of Vehicle Repair" procedure.

VERIFICATION OF VEHICLE REPAIR E680C266

After a repair, it is essential to verify that the fault has been corrected.

1. Connect scantool and select "Diagnostic Trouble Codes(DTCs)" mode.
2. Using a scantool, Clear DTC.
3. Operate the vehicle within DTC Enable conditions in General information.
4. Are any DTCs present?

YES

Go to the applicable troubleshooting procedure.

NO

System performing to specification at this time.

AT -54

AUTOMATIC TRANSAXLE (A5SR1/2)

DTC P0712 FLUID(OIL) TEMPERATURE SENSOR CIRCUIT - LOW

COMPONENT LOCATION E48B298D

Refer to DTC P0711.

GENERAL DESCRIPTION EA6EB3E2

Refer to DTC P0711.

DTC DESCRIPTION EFD3AE8

Refer to DTC P0711.

DTC DETECTING CONDITION E07AEA21

[DSL 2.5]

Item	Detecting Condition	Possible cause
DTC Strategy	<ul style="list-style-type: none">Fluctuation of A/T fluid temperature	ATF T/S :Automatic Transmission Fluid Temperature Sensor <ul style="list-style-type: none">OPEN IN CIRCUITFaulty ATF T/S 1Faulty TCM
Enable Conditions	<ul style="list-style-type: none">A/T range switch is D rangeVehicle speed 6.2MPH(10km/h)Throttle opening 12.5%Engine speed 305rpm	
Threshold value	<ul style="list-style-type: none">A/T fluid is below then -4°F for 10 minutes (refer fig.2 Diagnostic logic for ATF temp. sensor)	
Diagnostic Time	<ul style="list-style-type: none">10minutes accumulative total	
Fail Safe	<ul style="list-style-type: none">S-MODE is Inhibited5th gear is Inhibite	

[GSL 3.3/3.8]

Item	Detecting Condition	Possible cause
DTC Strategy	<ul style="list-style-type: none">Check the voltage range	ATF T/S : Automatic Transmission Fluid Temperature Sensor <ul style="list-style-type: none">OPEN IN CIRCUITFaulty ATF T/S 1
Enable Conditions	<ul style="list-style-type: none">Battery voltage > 10V	
Threshold value	<ul style="list-style-type: none">Input voltage < 0.05V	
Diagnostic Time	<ul style="list-style-type: none">More than 2 sec	
Fail Safe	<ul style="list-style-type: none">Fluid temperature is regarded as 80°C	

SPECIFICATION EA6B3DFD

Refer to DTC P0711.

MONITOR SCANTOOL DATA E2CB1D26

Refer to DTC P0711.

AUTOMATIC TRANSAXLE SYSTEM

AT -55

TERMINAL & CONNECTOR INSPECTION E23BB628

Refer to DTC P0711.

SIGNAL CIRCUIT INSPECTION E4D9E65E

1. Ignition "ON" & Engine "OFF".
2. Disconnect the "ATF 1[C06-1/C106-1] and ATF 2[C06-2/C106-2]" connector.
3. Measure the voltage between terminal "9" of the "ATF 1 [C06-1/C106-1]" harness connector and chassis ground.

Specification : Approx. 5 V

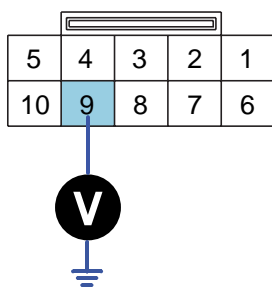

C06-1 [DSL 2.5]
C106-1 [GSL 3.3/3.8]

- 1.VIGN-OUT 1
- 2.DATA BIT 1
- 3.PSB 2
- 4.PSC 2
- 5.SEL 1
- 6.SEL 2
- 7.SEL 3
- 8.GND
- 9.ATF 1
- 10.VSP 1

SBLAT6112L

4. Is voltage within specifications?

YES

Go to "Component Inspection" procedure.

NO

Check for open in harness. Repair as necessary and Go to "Verification of Vehicle Repair" procedure.

COMPONENT INSPECTION E7BC367A

Refer to DTC P0711.

VERIFICATION OF VEHICLE REPAIR EDAE0B63

Refer to DTC P0711.

AT -56

AUTOMATIC TRANSAXLE (A5SR1/2)

DTC P0713 FLUID(OIL) TEMPERATURE SENSOR CIRCUIT - HIGH

COMPONENT LOCATION E2AA6EFF

Refer to DTC P0711.

GENERAL DESCRIPTION E2FC2200

Refer to DTC P0711.

DTC DESCRIPTION EC33B44D

Refer to DTC P0711.

DTC DETECTING CONDITION E96422CB

[DSL 2.5]

Item	Detecting Condition	Possible cause
DTC Strategy	<ul style="list-style-type: none">Fluctuation of A/T fluid temperature	ATF T/S :Automatic Transmission Fluid Temperature Sensor <ul style="list-style-type: none">OPEN IN CIRCUITFaulty ATF T/S 1Faulty TCM
Enable Conditions	<ul style="list-style-type: none">A/T range switch is D rangeVehicle speed 6.2MPH(10km/h)Throttle opening 12.5%Engine speed 305rpm	
Threshold value	<ul style="list-style-type: none">A/T fluid is over than 180degrees for 10 minutes(refer fig.2 Diagnostic logic for ATF temp. sensor)	
Diagnostic Time	<ul style="list-style-type: none">10minutes accumulative total	
Fail Safe	<ul style="list-style-type: none">S-MODE is Inhibited5th gear is Inhibite	

[GSL 3.3/3.8]

Item	Detecting Condition	Possible cause
DTC Strategy	<ul style="list-style-type: none">Check the voltage range	ATF T/S : Automatic Transmission Fluid Temperature Sensor <ul style="list-style-type: none">OPEN OR SHORT IN CIRCUITFaulty ATF T/S 1Faulty TCM
Enable Conditions	<ul style="list-style-type: none">Oil temp. at IG "ON" -39°CEngine speed > 1000rpmOutput speed 500rpmEngine coolant temp. 70°CDelay time = 160sec	
Threshold value	<ul style="list-style-type: none">Input voltage > 4.8V	
Diagnostic Time	<ul style="list-style-type: none">10 minutes accumulative total	
Fail Safe	<ul style="list-style-type: none">Fluid temperature is regarded as 80°C	

AUTOMATIC TRANSAXLE SYSTEM

AT -57

SPECIFICATION EF876B5E

Refer to DTC P0711.

MONITOR SCANTOOL DATA EC65CE6B

Refer to DTC P0711.

TERMINAL & CONNECTOR INSPECTION EFC0B06F

Refer to DTC P0711.

SIGNAL CIRCUIT INSPECTION ECAD37FF

Refer to DTC P0712.

COMPONENT INSPECTION E438B851

Refer to DTC P0711.

VERIFICATION OF VEHICLE REPAIR E5CF477D

Refer to DTC P0711.

DTC P0716 INPUT SPEED SENSOR RANGE/PERFORMANCE

COMPONENT LOCATION EB7BFDFE

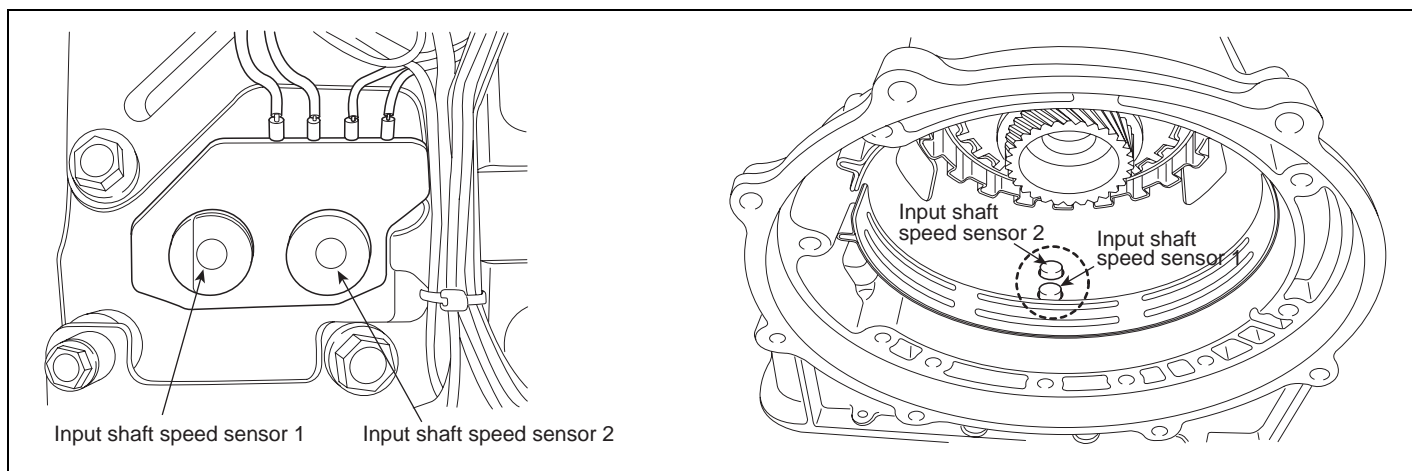

SBLAT6120L

GENERAL DESCRIPTION E3ABBCE0

The Input Sensor of RXC Auto transmission is composed of S1(Sensor1) and S2(Sensor2). S1 inputs signal to TCM only at 4th gear and S2 does at 1st, 2nd, 3rd, 4th and 5th gear. Therefore, sensing pulse frequency outputted from 2 of signal, TCM calculates Inputshaft speed and compute Turbine rotation. This value is mainly used to control the optimum fluid pressure during shifting.

DTC DESCRIPTION EF6DAECB

The TCM sets this code if an output pulse-signal is not detected, from the INPUT SPEED SENSOR 1 or 2, when the vehicle is running faster than 24.85MPH(40km/h). The Fail-Safe function will be set by the TCM if this code is detected.

DTC DETECTING CONDITION E6F78E7D

[DSL 2.5]

Item	Detecting Condition	Possible cause
DTC Strategy	<ul style="list-style-type: none"> Speed rationality check 	<ul style="list-style-type: none"> Signal circuit is open or short Sensor power circuit is open Sensor ground circuit is open Faulty INPUT SPEED SENSOR 1 Faulty TCM
Enable Conditions	<ul style="list-style-type: none"> Vehicle speed > 24.85MPH(40km/h) Engine speed > 1500 rpm Throttle opening 12.5% A/T range switch is D range 	
Threshold value	<ul style="list-style-type: none"> Input speed < 600rpm 	
Diagnostic Time	<ul style="list-style-type: none"> more than 5sec 	
Fail Safe	<ul style="list-style-type: none"> "Nt" is regarded as 600rpm(Nt = 600rpm) S-MODE is Inhibited 5th gear is Inhibited 	

AUTOMATIC TRANSAXLE SYSTEM

[GSL 3.3/3.8]

Item	Detecting Condition	Possible cause
DTC Strategy	<ul style="list-style-type: none"> • Speed rationality check 	<ul style="list-style-type: none"> • Signal circuit is open or short • Sensor power circuit is open • Sensor ground circuit is open • Faulty INPUT SPEED SENSOR 1 • Faulty TCM
Enable Conditions	<ul style="list-style-type: none"> • Battery voltage > 10V • Output speed > 200rpm • Engine speed > 700 rpm • State of "TRANSMISSION" is "STATIC" • The time after the last shift was finished 500sec 	
Threshold value	<ul style="list-style-type: none"> • Input speed1 > 50rpm 	
Diagnostic Time	<ul style="list-style-type: none"> • More than 2sec 	
Fail Safe	<ul style="list-style-type: none"> • "Input speed" is regarded as 600rpm(Nt = 600rpm) • Shift prevention over 4th gear • Prevention of manual shift • Prevention of pressure adaptation 	

SPECIFICATION

E5ACEF55

NAME	PIN NO	Measurement condition	Spec
Turbine Sensor1	6	<ul style="list-style-type: none"> • 1gear • 12.42MPH(20km/h) • Idle SW OFF 	Approx. 1.1K(Hz)
Turbine Sensor2	7	<ul style="list-style-type: none"> • 4gear • 31MPH(50km/h) • Idle SW OFF 	

CAUTION

Scan tool data link cable is maintain to connecting condition.

SIGNAL WAVEFORM & DATA

EB50540C

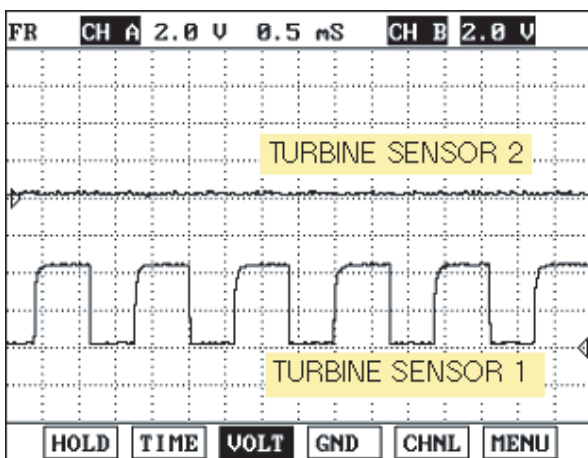

FIG.1)

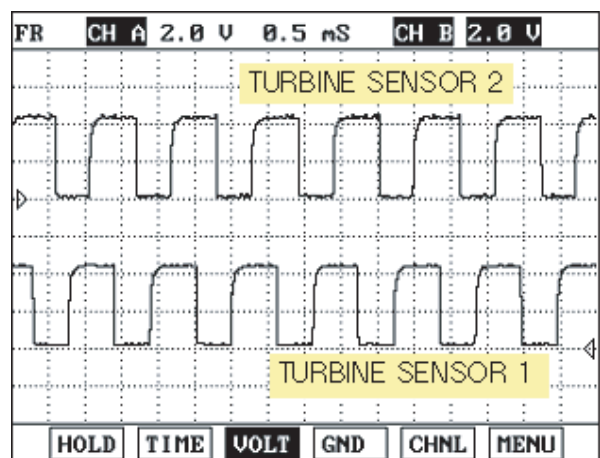

FIG.2)

FIG.1) 1GEAR

FIG.2) 4 GEAR

Caution:TURBINE SENSOR 2 CAN BE DETECTED 5V IN FIG.1

MONITOR SCANTOOL DATA E1F16A86

1. Connect scantool to data link connector(DLC).
2. Engine "ON".
3. Monitor the "INPUT SPEED SENSOR 1" parameter on the scantool.
4. Driving at speed of over 12.42MPH(20km/h) at 1gear.

Specification : Increasing Gradually

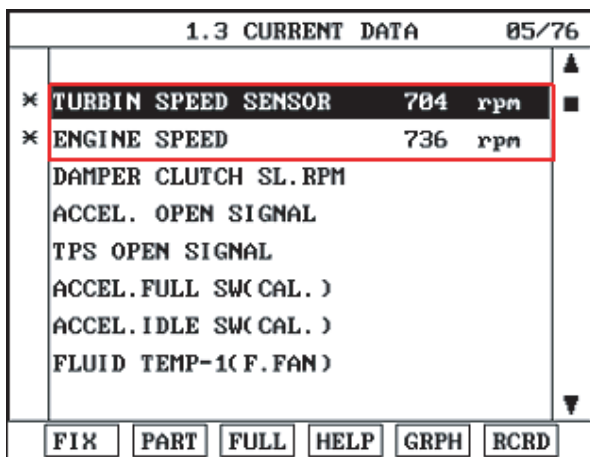

FIG.1)

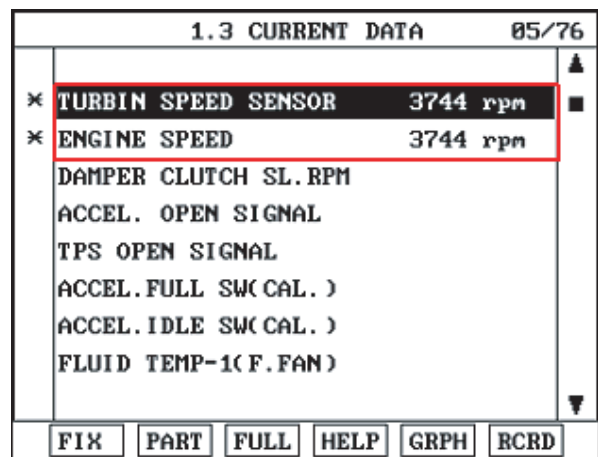

FIG.2)

FIG.1) Low speed
FIG.2) High speed

SBLAT6122L

5. Does "INPUT SPEED SENSOR" follow the reference data?

YES

Fault is intermittent caused by poor contact in the sensor's and/or PCM/TCM's connector or was repaired and PCM/TCM memory was not cleared. Thoroughly check connectors for looseness, poor connection, bending, corrosion, contamination, deterioration or damage. Repair or replace as necessary and go to "Verification of Vehicle Repair" procedure.

NO

Go to "Terminal & connector inspection" procedure.

TERMINAL & CONNECTOR INSPECTION EB2FE4FA

1. Many malfunctions in the electrical system are caused by poor harness and terminals. Faults can also be caused by interference from other electrical systems, and mechanical or chemical damage.
2. Thoroughly check connectors for looseness, poor connection, bending, corrosion, contamination, deterioration, or damage.
3. Has a problem been found?

YES

Repair as necessary and go to "Verification of Vehicle Repair" procedure.

NO

Go to "Signal circuit inspection" procedure.

SIGNAL CIRCUIT INSPECTION E9BE3DEC

1. Ignition "ON" & Engine "OFF".
2. Disconnect the "C06-3/C106-3" connector.
3. Measure voltage between terminal "6" of the C06-3/C106-3 harness connector and chassis ground.

Specification : Approx. 5 V

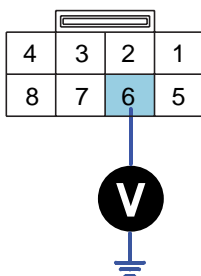

C06-3 [DSL 2.5]
C106-3 [GSL 3.3/3.8]

1. TRANSMISSION RANGE SWITCH SW1
2. TRANSMISSION RANGE SWITCH SW2
3. TRANSMISSION RANGE SWITCH SW3
4. TRANSMISSION RANGE SWITCH SW4
6. **TURBINE SENSOR 1**
7. TURBINE SENSOR 2

SBLAT6123L

4. Is voltage within specifications?

YES

Go to "Power supply circuit inspection" procedure.

NO

Check for open or short in harness. Repair as necessary and Go to "Verification of Vehicle Repair" procedure. If signal circuit in harness is OK, Go to "Check TCM" of the "Component Inspection" procedure.

POWER SUPPLY CIRCUIT INSPECTION E254C4E3

1. Remove "OIL PAN".
2. Ignition "ON", Engine "OFF".
3. Connect the "C06-3/C106-3 and Shift CM" connector.
4. Measure resistance between terminal "4" of the TURBINE SENSOR harness connector and chassis ground.

Specification : approx. 12V

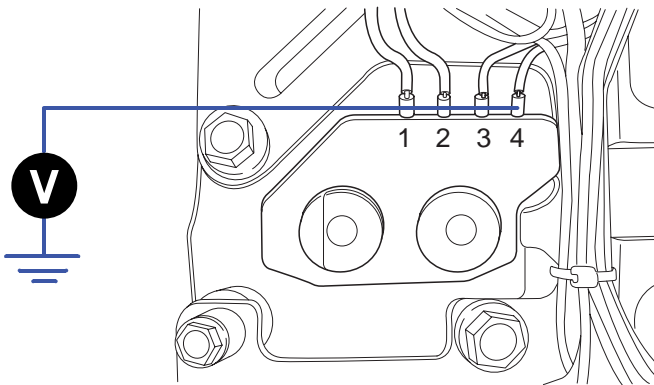

SBLAT6124L

5. Is voltage within specifications ?

YES

Go to "Ground circuit inspection" procedure.

NO

Check for open or short in harness. Repair as necessary and Go to "Verification of Vehicle Repair" procedure. If power circuit in harness is OK, Substitute with a known-good Shift CM and check for proper operation. If the problem is corrected, replace Shift CM as necessary and go to "Verification of Vehicle Repair" procedure.

GROUND CIRCUIT INSPECTION EFFB9D41

1. Remove "OIL PAN".
2. Engine "OFF".
3. Disconnect the "C06-3/C106-3 and Shift CM" connector.
4. Measure resistance between terminal "3" of the INPUT SPEED SENSOR harness connector and chassis ground.

Specification : approx. 0

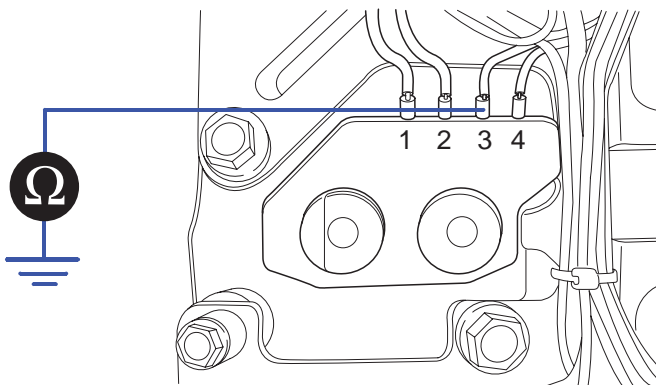

SBLAT6125L

5. Is resistance within specifications?

YES

Go to "Component inspection" procedure.

NO

Check for open in harness. Repair as necessary and Go to "Verification of Vehicle Repair" procedure.

COMPONENT INSPECTION EFBD73FE

1. Check "TURBINE SENSOR 2"

- 1) Ignition "ON" & Engine "OFF".
- 2) Connect the "C06-3/C106-3" connector.
- 3) Measure Frequency between terminal "6" of the C06-3/C106-3 harness connector and chassis ground.

Specification :

NAME	PIN NO	Measurement condition	Spec
Turbine Sensor1	6	<ul style="list-style-type: none">• 1gear• 12.42MPH(20km/h)• Idle SW OFF	Approx. 1.1K(Hz)
Turbine Sensor2	7	<ul style="list-style-type: none">• 4gear• 31MPH(50km/h)• Idle SW OFF	

 **CAUTION**

Scan tool data link cable is maintain to connecting condition.

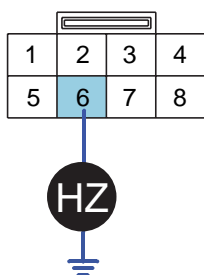

C06-3 [DSL 2.5]
C106-3 [GSL 3.3/3.8]
Component side

- 1. TRANSMISSION RANGE SWITCH SW1
- 2. TRANSMISSION RANGE SWITCH SW2
- 3. TRANSMISSION RANGE SWITCH SW3
- 4. TRANSMISSION RANGE SWITCH SW4
- 6. **TURBINE SENSOR 1**
- 7. TURBINE SENSOR 2

SBLAT6126L

4) Is frequency within specifications?

YES

Go to "CHECK TCM " as below.

NO

Replace "TURBINE SENSOR" as necessary and Go to "Verification of Vehicle Repair" procedure.

2. CHECK TCM

- 1) Ignition "ON" & Engine "OFF".
- 2) Disconnect "C06-3/C106-3" connector.
- 3) Install scantool and select a SIMU-SCAN.
- 4) Simulate frequency to TURBINE SENSOR 1 signal circuit.

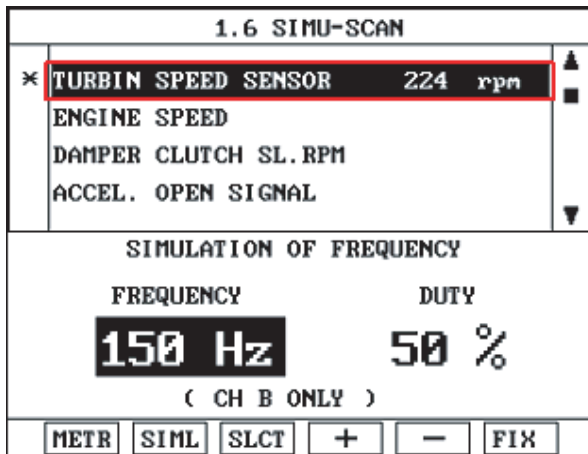

FIG.1)

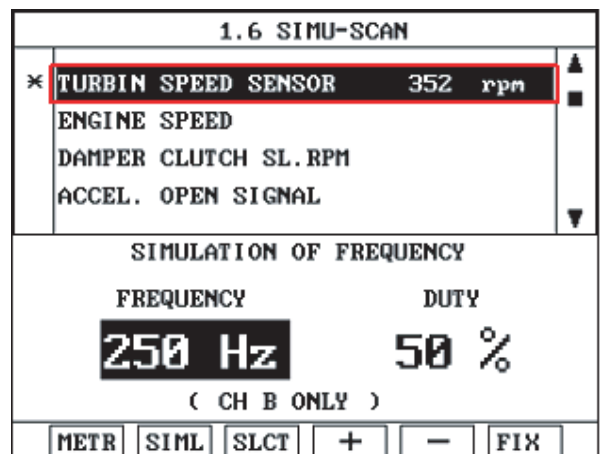

FIG.2)

FIG.1) INPUT 150HZ → 224rpm
FIG.2) INPUT 250HZ → 352rpm

※ The values are subject to change according to vehicle model or conditions.

SBLAT6127L

5) Is "TURBINE SENSOR 1" signal value changed according to simulation frequency?

YES

Thoroughly check connectors for looseness, poor connection, bending, corrosion, contamination, deterioration, or damage. Repair or replace as necessary and then go to "Verification of Vehicle Repair" procedure.

NO

Substitute with a known-good TCM and check for proper operation. If the problem is corrected, replace TCM as necessary and go to "Verification of Vehicle Repair" procedure.

VERIFICATION OF VEHICLE REPAIR E1EE0F5E

After a repair, it is essential to verify that the fault has been corrected.

1. Connect scantool and select "Diagnostic Trouble Codes(DTCs)" mode.
2. Using a scantool, Clear DTC.
3. Operate the vehicle within DTC Enable conditions in General information.
4. Are any DTCs present?

YES

Go to the applicable troubleshooting procedure.

NO

System performing to specification at this time.

DTC P0717 INPUT SPEED SENSOR CIRCUIT - NO SIGNAL

COMPONENT LOCATION E92DD061

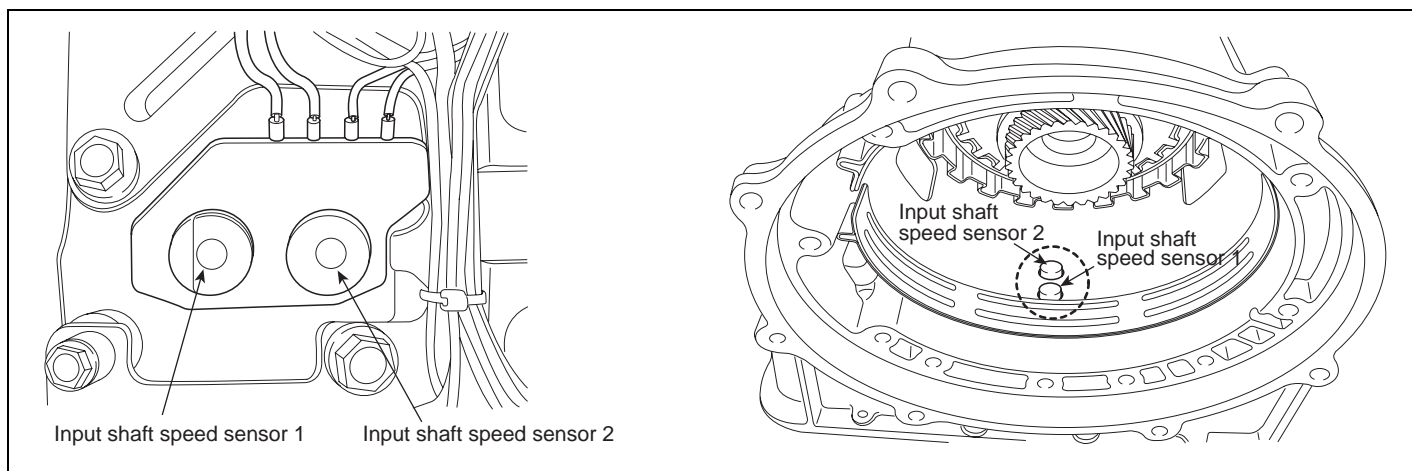

SBLAT6120L

GENERAL DESCRIPTION ECF4EAEA

The Input Sensor of RXC Auto transmission is composed of S1(Sensor1) and S2(Sensor2). S1 inputs signal to TCM only at 4th gear and S2 does at 1st, 2nd, 3rd, 4th and 5th gear. Therefore, sensing pulse frequency outputted from 2 of signal, TCM calculates Inputshaft speed and compute Turbine rotation. This value is mainly used to control the optimum fluid pressure during shifting.

DTC DESCRIPTION E5DB565D

The TCM sets this code if an output pulse-signal is not detected, from the INPUT SPEED SENSOR 1 or 2, when the vehicle is running faster than 24.85MPH(40km/h). The Fail-Safe function will be set by the TCM if this code is detected.

DTC DETECTING CONDITION EF2A0530

Item	Detecting Condition	Possible cause
DTC Strategy	<ul style="list-style-type: none"> Speed rationality check 	<ul style="list-style-type: none"> Signal circuit is open or short Sensor power circuit is open Sensor ground circuit is open Faulty INPUT SPEED SENSOR 1 Faulty TCM
Enable Conditions	<ul style="list-style-type: none"> Battery voltage > 10V Output speed > 1000rpm Engine speed(Only current gear is the 1st gear) > 3000 rpm Engine speed(2.3.4.5 gear) > 700 rpm Position lever = "D" 	
Threshold value	<ul style="list-style-type: none"> Input speed1 50rpm 	
Diagnostic Time	<ul style="list-style-type: none"> More than 2sec 	
Fail Safe	<ul style="list-style-type: none"> "Input speed" is regarded as 600rpm(Nt = 600rpm) Shift prevention over 4th gear Prevention of manual shift Prevention of pressure adaptation 	

AUTOMATIC TRANSAXLE SYSTEM

AT -67

SPECIFICATION E0AA6D77

NAME	PIN NO	Measurement condition	Spec
Turbine Sensor1	6	<ul style="list-style-type: none"> • 1gear • 12.42MPH(20km/h) • Idle SW OFF 	Approx. 1.1K(Hz)
Turbine Sensor2	7	<ul style="list-style-type: none"> • 4gear • 31MPH(50km/h) • Idle SW OFF 	

CAUTION

Scan tool data link cable is maintain to connecting condition.

SIGNAL WAVEFORM EA4D3AAD

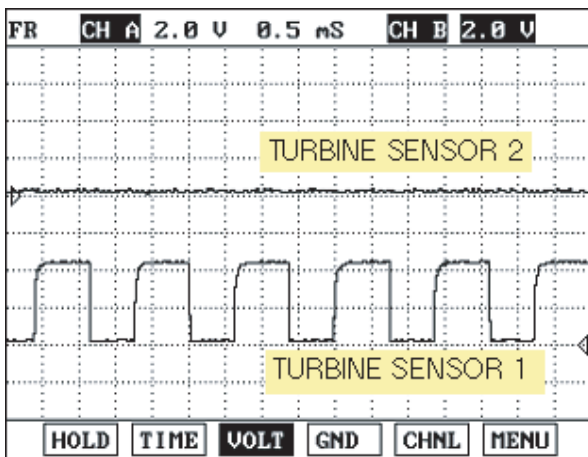

FIG.1)

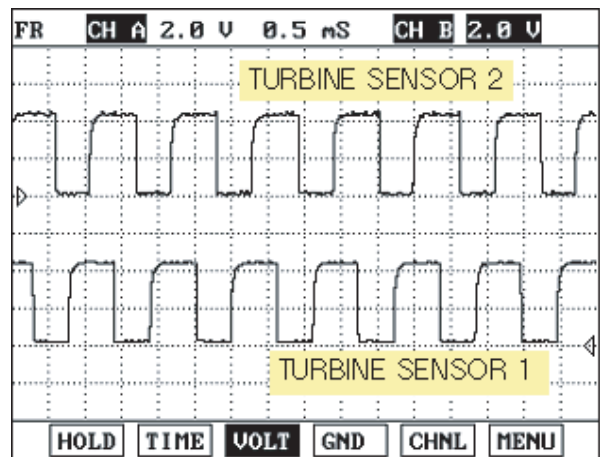

FIG.2)

FIG.1) 1GEAR
FIG.2) 4 GEAR

Caution: TURBINE SENSOR 2 CAN BE DETECTED 5V IN FIG.1

SBLAT6121L

MONITOR SCANTOOL DATA E5FF0AEF

1. Connect scantool to data link connector(DLC).
2. Engine "ON".
3. Monitor the "INPUT SPEED SENSOR 1" parameter on the scantool.
4. Driving at speed of over 12.42MPH(20km/h) at 1gear.

Specification : Increasing Gradually

1.11 CURRENT DATA 01/59	
ENGINE SPEED	786 rpm
INPUT SPEED(PC-A)	658.8rpm
TURBIN SPEED SENDOR 1	8.8 rpm
TURBIN SPEED SENDOR 2	628.8rpm
TCC SLIP RPM	25.8 rpm
CURRENT GEAR POSITION	P N
SELECTED LEVER RANGE	P
INHIBITOR SWITCH 1	

FIG.1)

1.11 CURRENT DATA 01/59	
ENGINE SPEED	661 rpm
INPUT SPEED(PC-A)	8.8 rpm
TURBIN SPEED SENDOR 1	8.8 rpm
TURBIN SPEED SENDOR 2	8.8 rpm
TCC SLIP RPM	658.8rpm
CURRENT GEAR POSITION	REVERSE
SELECTED LEVER RANGE	R
INHIBITOR SWITCH 1	

FIG.2)

1.11 CURRENT DATA 01/59	
ENGINE SPEED	656 rpm
INPUT SPEED(PC-A)	8.8 rpm
TURBIN SPEED SENDOR 1	8.8 rpm
TURBIN SPEED SENDOR 2	8.8 rpm
TCC SLIP RPM	654.8rpm
CURRENT GEAR POSITION	1 GEAR
SELECTED LEVER RANGE	D
INHIBITOR SWITCH 1	

FIG.3)

1.11 CURRENT DATA 01/59	
ENGINE SPEED	1927 rpm
INPUT SPEED(PC-A)	1898.rpm
TURBIN SPEED SENDOR 1	8.8 rpm
TURBIN SPEED SENDOR 2	1887.rpm
TCC SLIP RPM	14.8 rpm
CURRENT GEAR POSITION	1 GEAR
SELECTED LEVER RANGE	D
INHIBITOR SWITCH 1	

FIG.4)

1.11 CURRENT DATA 01/59	
ENGINE SPEED	1005 rpm
INPUT SPEED(PC-A)	1862.rpm
TURBIN SPEED SENDOR 1	8.8 rpm
TURBIN SPEED SENDOR 2	1857.rpm
TCC SLIP RPM	26.8 rpm
CURRENT GEAR POSITION	2 GEAR
SELECTED LEVER RANGE	D
INHIBITOR SWITCH 1	

FIG.5)

1.11 CURRENT DATA 01/59	
ENGINE SPEED	2148 rpm
INPUT SPEED(PC-A)	2116.rpm
TURBIN SPEED SENDOR 1	8.8 rpm
TURBIN SPEED SENDOR 2	2879.rpm
TCC SLIP RPM	32.8 rpm
CURRENT GEAR POSITION	3 GEAR
SELECTED LEVER RANGE	D
INHIBITOR SWITCH 1	

FIG.6)

1.11 CURRENT DATA 01/59	
ENGINE SPEED	1907 rpm
INPUT SPEED(PC-A)	1986.rpm
TURBIN SPEED SENDOR 1	1838.rpm
TURBIN SPEED SENDOR 2	3822.rpm
TCC SLIP RPM	8.8 rpm
CURRENT GEAR POSITION	4 GEAR
SELECTED LEVER RANGE	D
INHIBITOR SWITCH 1	

FIG.7)

1.11 CURRENT DATA 01/59	
ENGINE SPEED	2838 rpm
INPUT SPEED(PC-A)	2848.rpm
TURBIN SPEED SENDOR 1	8.8 rpm
TURBIN SPEED SENDOR 2	2872.rpm
TCC SLIP RPM	8.8 rpm
CURRENT GEAR POSITION	5 GEAR
SELECTED LEVER RANGE	D
INHIBITOR SWITCH 1	

FIG.8)

FIG.1) "P,N" range

FIG.2) "R" range

FIG.3) "D" range 1st gear, vehicle speed = 0

FIG.4) "D" range 1st gear

FIG.5) "D" range 2nd gear

FIG.6) "D" range 3rd gear

FIG.7) "D" range 4th gear

FIG.8) "D" range 5th gear

AUTOMATIC TRANSAXLE SYSTEM

AT -69

5. Does "INPUT SPEED SENSOR" follow the reference data?

YES

Fault is intermittent caused by poor contact in the sensor's and/or PCM/TCM's connector or was repaired and PCM/TCM memory was not cleared. Thoroughly check connectors for looseness, poor connection, bending, corrosion, contamination, deterioration or damage. Repair or replace as necessary and go to "Verification of Vehicle Repair" procedure.

NO

Go to "Terminal & connector inspection" procedure.

TERMINAL & CONNECTOR INSPECTION EC63CFB6

1. Many malfunctions in the electrical system are caused by poor harness and terminals. Faults can also be caused by interference from other electrical systems, and mechanical or chemical damage.
2. Thoroughly check connectors for looseness, poor connection, bending, corrosion, contamination, deterioration, or damage.
3. Has a problem been found?

YES

Repair as necessary and go to "Verification of Vehicle Repair" procedure.

NO

Go to "Signal circuit inspection" procedure.

SIGNAL CIRCUIT INSPECTION EABF6385

1. Ignition "ON" & Engine "OFF".
2. Disconnect the "C106-3" connector.
3. Measure voltage between terminal "6" of the C106-3 harness connector and chassis ground.

Specification : Approx. 5 V

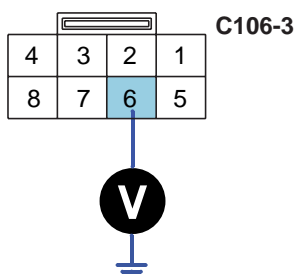

1. TRANSMISSION RANGE SWITCH SW1
2. TRANSMISSION RANGE SWITCH SW2
3. TRANSMISSION RANGE SWITCH SW3
4. TRANSMISSION RANGE SWITCH SW4
6. **TURBINE SENSOR 1**
7. TURBINE SENSOR 2

SBLAT6204L

4. Is voltage within specifications?

YES

Go to "Power supply circuit inspection" procedure.

NO

Check for open or short in harness. Repair as necessary and Go to "Verification of Vehicle Repair" procedure. If signal circuit in harness is OK, Go to "Check TCM" of the "Component Inspection" procedure.

POWER SUPPLY CIRCUIT INSPECTION EDD609D6

1. Remove "OIL PAN".
2. Ignition "ON", Engine "OFF".
3. Connect the "C106-3 and Shift CM" connector.
4. Measure resistance between terminal "4" of the TURBINE SENSOR harness connector and chassis ground.

Specification : approx. 12V

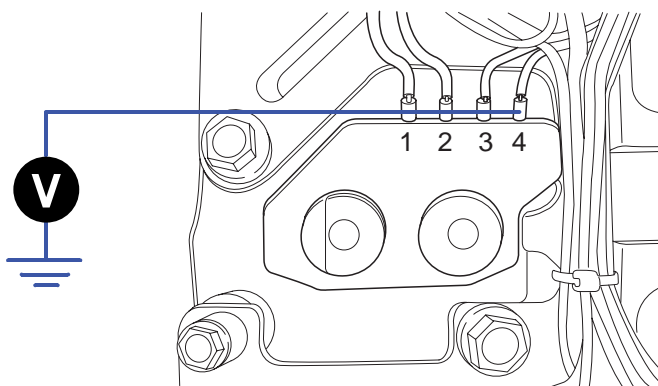

SBLAT6124L

5. Is voltage within specifications ?

YES

Go to "Ground circuit inspection" procedure.

NO

Check for open or short in harness. Repair as necessary and Go to "Verification of Vehicle Repair" procedure. If power circuit in harness is OK, Substitute with a known-good Shift CM and check for proper operation. If the problem is corrected, replace Shift CM as necessary and go to "Verification of Vehicle Repair" procedure.

GROUND CIRCUIT INSPECTION EB485BFF

1. Remove "OIL PAN".
2. Engine "OFF".
3. Disconnect the "C106-3 and Shift CM" connector.
4. Measure resistance between terminal "3" of the INPUT SPEED SENSOR harness connector and chassis ground.

Specification : approx. 0

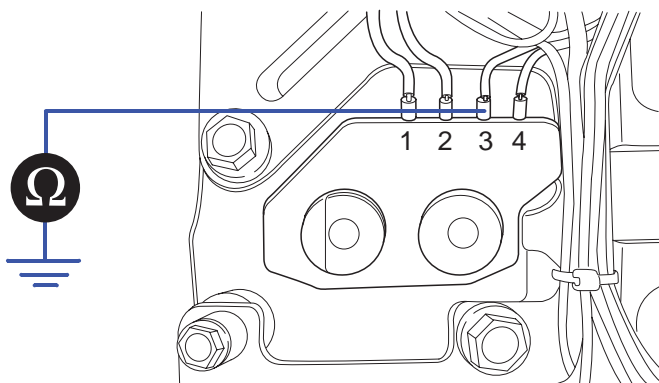

SBLAT6125L

5. Is resistance within specifications?

YES

Go to "Component inspection" procedure.

NO

Check for open in harness. Repair as necessary and Go to "Verification of Vehicle Repair" procedure.

COMPONENT INSPECTION ED2F6EB7

1. Check "TURBINE SENSOR 2"

- 1) Ignition "ON" & Engine "OFF".
- 2) Connect the "C106-3" connector.
- 3) Measure Frequency between terminal "6" of the C106-3 harness connector and chassis ground.

Specification :

NAME	PIN NO	Measurement condition	Spec
Turbine Sensor1	6	<ul style="list-style-type: none">• 1gear• 12.42MPH(20km/h)• Idle SW OFF	Approx. 1.1K(Hz)
Turbine Sensor2	7	<ul style="list-style-type: none">• 4gear• 31MPH(50km/h)• Idle SW OFF	

⚠ CAUTION

Scan tool data link cable is maintain to connecting condition.

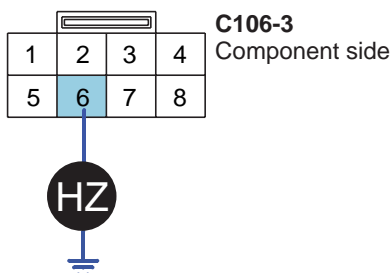

1. TRANSMISSION RANGE SWITCH SW1
2. TRANSMISSION RANGE SWITCH SW2
3. TRANSMISSION RANGE SWITCH SW3
4. TRANSMISSION RANGE SWITCH SW4
6. **TURBINE SENSOR 1**
7. TURBINE SENSOR 2

SBLAT6205L

4) Is frequency within specifications?

YES

Go to "CHECK TCM " as below.

NO

Replace "TURBINE SENSOR" as necessary and Go to "Verification of Vehicle Repair" procedure.

2. CHECK TCM

- 1) Ignition "ON" & Engine "OFF".
- 2) Disconnect "C106-3" connector.
- 3) Install scantool and select a SIMU-SCAN.
- 4) Simulate frequency to TURBINE SENSOR 1 signal circuit.

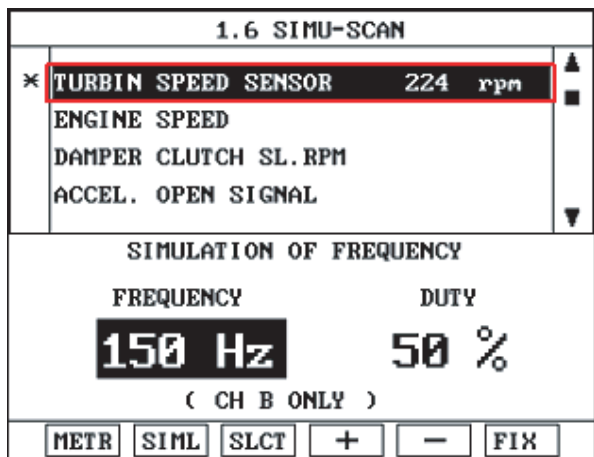

FIG.1)

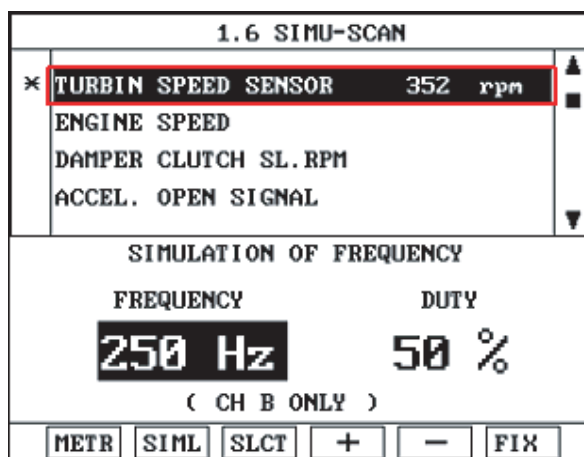

FIG.2)

FIG.1) INPUT 150HZ → 224rpm

FIG.2) INPUT 250HZ → 352rpm

※ The values are subject to change according to vehicle model or conditions.

SBLAT6127L

5) Is "TURBINE SENSOR 1" signal value changed according to simulation frequency?

YES

Thoroughly check connectors for looseness, poor connection, bending, corrosion, contamination, deterioration, or damage. Repair or replace as necessary and then go to "Verification of Vehicle Repair" procedure.

NO

Substitute with a known-good TCM and check for proper operation. If the problem is corrected, replace TCM as necessary and go to "Verification of Vehicle Repair" procedure.

VERIFICATION OF VEHICLE REPAIR E06CFAEB

After a repair, it is essential to verify that the fault has been corrected.

1. Connect scantool and select "Diagnostic Trouble Codes(DTCs)" mode.
2. Using a scantool, Clear DTC.
3. Operate the vehicle within DTC Enable conditions in General information.
4. Are any DTCs present?

YES

Go to the applicable troubleshooting procedure.

NO

System performing to specification at this time.

DTC P0721 AT OUTPUT SPEED SENSOR CIRCUIT - OPEN OR SHORT(GND)

COMPONENT LOCATION EDFEC73C

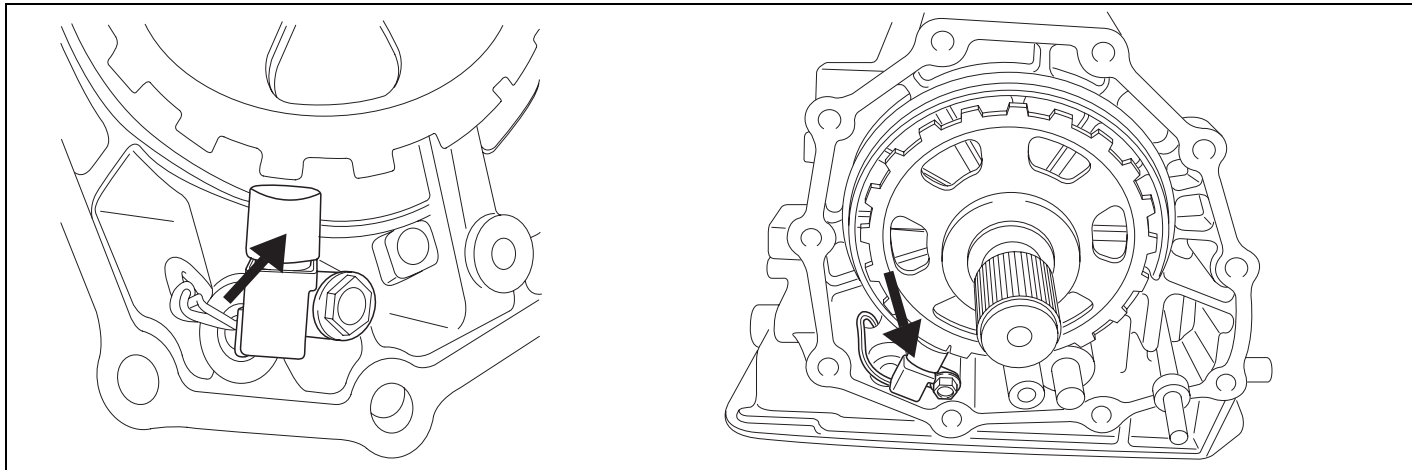

SBLAT6130L

GENERAL DESCRIPTION EA08C074

The OUTPUT SPEED SENSOR outputs waveform signals according to the revolutions of the output shaft of the transmission. The Output Speed Sensor is installed in front of the Parking Gear to determine the Parking Gear rpms by counting the frequency of the pulses. This value, together with the throttle position data, is mainly used to decide the optimum gear position.

DTC DESCRIPTION E55BEB33

The TCM sets this code if the calculated value of the signals is noticeably different from the value calculated, using the Vehicle Speed Sensor output, when the vehicle is running faster than 18.6MPH(30km/h). The TCM will initiate the fail safe function if this code is detected.

DTC DETECTING CONDITION E1DCBBC8

[DSL 2.5]

Item	Detecting Condition	Possible cause
DTC Strategy	<ul style="list-style-type: none"> Speed rationality check 	<ul style="list-style-type: none"> Signal circuit is open or short Sensor power circuit is open Sensor ground circuit is open Faulty OUTPUT SPEED SENSOR Faulty TCM
Enable Conditions	<ul style="list-style-type: none"> Vehicle speed 18.6MPH(30km/h) or engine speed > 3500 rpm (in case of failure at vehicle speed) A/T range switch is D range Throttle opening 12.5% 	
Threshold value	<ul style="list-style-type: none"> output speed < 5 pulse (Reference 18 pulses per 1 output revolution) 	
Diagnostic Time	<ul style="list-style-type: none"> more than 2sec 	
Fail Safe	<ul style="list-style-type: none"> Substitute for VSS. If Faulty in VSS, Locked into 4th gear (RETURN TO FAILSAFE: 5 < Vehicle speed < 20 SENSOR 1,2) 	

AUTOMATIC TRANSAXLE SYSTEM

AT -75

[GSL 3.3/3.8]

Item	Detecting Condition	Possible cause
DTC Strategy	<ul style="list-style-type: none"> • Speed rationality check 	<ul style="list-style-type: none"> • Signal circuit is open or short • Sensor power circuit is open • Sensor ground circuit is open • Faulty OUTPUT SPEED SENSOR • Faulty TCM
Enable Conditions	<ul style="list-style-type: none"> • Battery voltage > 10V • Lever position = "D" • Input speed > 1200 rpm • Output speed > 3000 rpm 	
Threshold value	<ul style="list-style-type: none"> • Output speed = 0 rpm 	
Diagnostic Time	<ul style="list-style-type: none"> • More than 4sec 	
Fail Safe	<ul style="list-style-type: none"> • Shift prevention over 4th gear • Prevention of manual shift • Prevention of pressure adaptation • Output speed from vehicle speed 	

SPECIFICATION E3E77D7E

NAME	PIN NO	Measurement condition	Spec
OUTPUT SPEED SENSOR	10	<ul style="list-style-type: none"> • 12.42MPH(20km/h) 	Approx. 149(Hz)

SIGNAL WAVEFORM E9878B7C

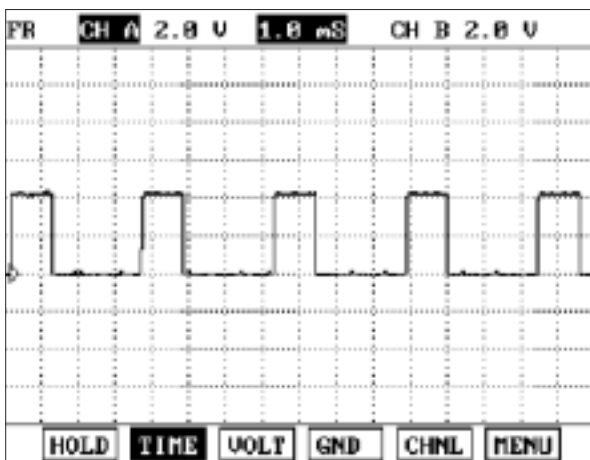

FIG.1)

FIG.1) LOW - SPEED
FIG.2) HIGH - SPEED

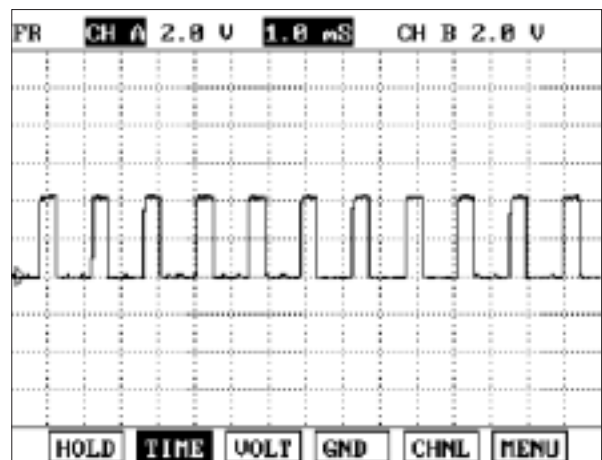

FIG.2)

SBLAT6131L

MONITOR SCANTOOL DATA EF0CD50F

1. Connect scantool to data link connector(DLC).
2. Engine "ON".
3. Monitor the "OUTPUT SPEED SENSOR" parameter on the scantool.
4. Driving at speed of over 5km/h.

Specification : Increasing Gradually

1.3 CURRENT DATA			02/76
×	USS 1(A/T)	11 MPH	
×	USS 2(ECU)	11 MPH	
×	OUTPUT SPEED SNSR	448 rpm	
×	TURBIN SPEED SENSOR	1760 rpm	
×	ENGINE SPEED	1760 rpm	
×	CURRENT GEAR POS.	1 GEAR	
×	CURRENT SHIFT MODE	SPORTS	
×	SELECTED LEVER RANGE	SPORTS	

FIG.1)

1.3 CURRENT DATA			02/76
×	USS 1(A/T)	50 MPH	
×	USS 2(ECU)	50 MPH	
×	OUTPUT SPEED SNSR	2016 rpm	
×	TURBIN SPEED SENSOR	1664 rpm	
×	ENGINE SPEED	1728 rpm	
×	CURRENT GEAR POS.	5 GEAR	
×	CURRENT SHIFT MODE	SPORTS	
×	SELECTED LEVER RANGE	D	

FIG.2)

FIG.1) Low-speed
FIG.2) High-speed

SBLAT6132L

5. Does "OUTPUT SPEED SENSOR" follow the reference data?

YES

Fault is intermittent caused by poor contact in the sensor's and/or PCM/TCM's connector or was repaired and PCM/TCM memory was not cleared. Thoroughly check connectors for looseness, poor connection, bending, corrosion, contamination, deterioration or damage. Repair or replace as necessary and go to "Verification of Vehicle Repair" procedure.

NO

Go to "Terminal & connector inspection" procedure.

TERMINAL & CONNECTOR INSPECTION EC2FFE16

- Many malfunctions in the electrical system are caused by poor harness and terminals. Faults can also be caused by interference from other electrical systems, and mechanical or chemical damage.
- Thoroughly check connectors for looseness, poor connection, bending, corrosion, contamination, deterioration, or damage.
- Has a problem been found?

YES

Repair as necessary and go to "Verification of Vehicle Repair" procedure.

NO

Go to "Signal circuit inspection" procedure.

SIGNAL CIRCUIT INSPECTION EFD1E861

1. CHECK "OUTPUT SPEED SENSOR SIGNAL CIRCUIT 1"

- 1) Ignition "ON" & Engine "OFF".
- 2) Disconnect the "C06-1/C106-1" connector.
- 3) Measure voltage between terminal "10" of the C06-1/C106-1 harness connector and chassis ground.

Specification : approx. 5V

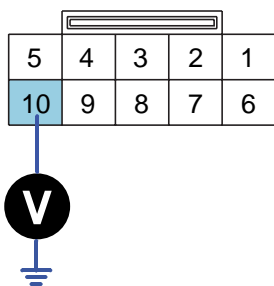

C06-1 [DSL 2.5]
C106-1 [GSL 3.3/3.8]

- 1.VIGN-OUT 1
- 2.DATA BIT 1
- 3.PSB 2
- 4.PSC 2
- 5.SEL 1
- 6.SEL 2
- 7.SEL 3
- 8.GND
- 9.ATF 1
- 10.OUTPUT SPEED SENSOR

SBLAT6133L

4) Is voltage within specifications?

YES

Go to "OUTPUT SPEED SENSOR SIGNAL CIRCUIT 2" as below.

NO

Check for open or short in harness. Repair as necessary and Go to "Verification of Vehicle Repair" procedure. If signal circuit in harness is OK, Go to "Component Inspection" procedure.

2. CHECK "OUTPUT SPEED SENSOR SIGNAL CIRCUIT 2"

- 1) Remove "OIL PAN".
- 2) Connect the "C06-1/C106-1" connector.
- 3) Ignition "ON" & Engine "OFF".
- 4) Disconnect the "OUTPUT SPEED SENSOR" connector.

- 5) Measure voltage between terminal "WHITE COLOR" of the OUTPUT SPEED SENSOR harness connector and chassis ground.

Specification : approx. 5V

(TRANSMISSION RANGE SWITCH SIDE)

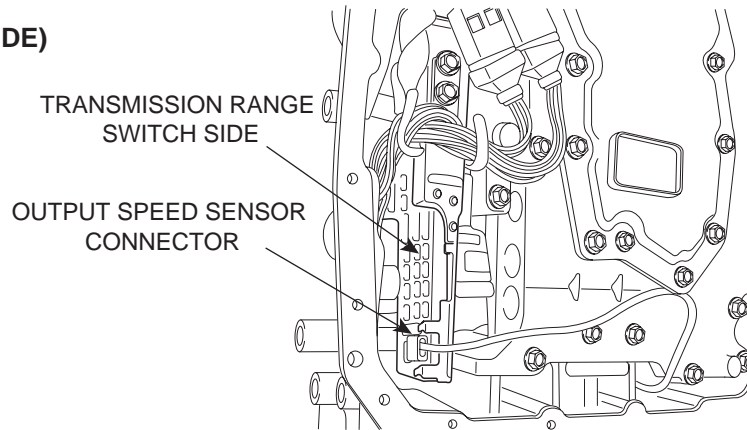
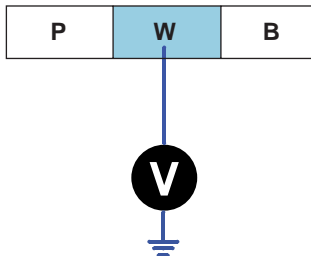

SBLAT6134L

- 6) Is voltage within specifications?

YES

Go to "Power supply circuit inspection" procedure.

NO

Check for open or short in harness(H-02[A]~TRANSMISSION RANGE SWITCH). Repair as necessary and Go to "Verification of Vehicle Repair" procedure.

If signal circuit in harness is OK, Replace "TRANSMISSION RANGE SWITCH" as necessary and Go to "Verification of Vehicle Repair" procedure.

POWER SUPPLY CIRCUIT INSPECTION E990A97A

1. Remove "OIL PAN".
2. Connect the "C06-1/C106-1" connector.
3. Ignition "ON" & Engine "OFF".
4. Disconnect the "OUTPUT SPEED SENSOR" connector.
5. Measure voltage between terminal "PINK COLOR" of the OUTPUT SPEED SENSOR harness connector and chassis ground.

Specification : approx. 12V

(TRANSMISSION RANGE SWITCH SIDE)

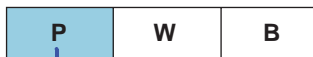

TRANSMISSION RANGE SWITCH SIDE
OUTPUT SPEED SENSOR CONNECTOR

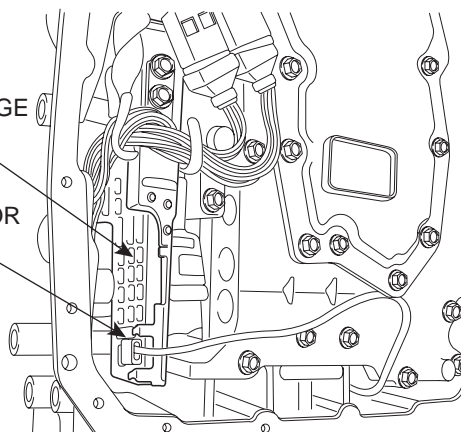

SBLAT6135L

6. Is voltage within specifications?

YES

Go to "Ground circuit Inspection" procedure.

NO

Replace "TRANSMISSION RANGE SWITCH" as necessary and Go to "Verification of Vehicle Repair" procedure.

GROUND CIRCUIT INSPECTION E3E15A3E

1. Ignition "OFF" & Engine "OFF".
2. Remove "OIL PAN".
3. Connect the "C06-1/C106-1" connector.
4. Disconnect the "OUTPUT SPEED SENSOR" connector.
5. Measure resistance between terminal "BLACK COLOR" of the OUTPUT SPEED SENSOR harness connector and chassis ground.

Specification : approx. 0

(TRANSMISSION RANGE SWITCH SIDE)

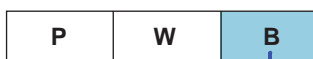

TRANSMISSION RANGE SWITCH SIDE
OUTPUT SPEED SENSOR CONNECTOR

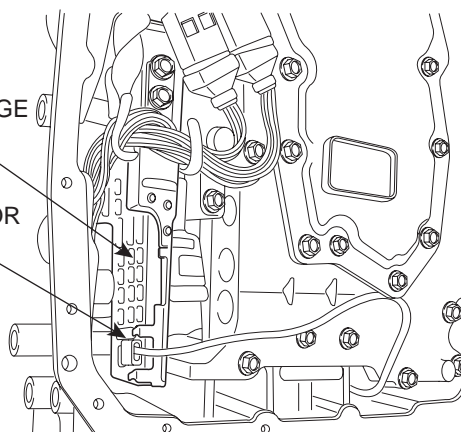

SBLAT6136L

6. Is resistance within specifications?

YES

Substitute with a known-good "OUTPUT SPEED SENSOR" and check for proper operation. If the problem is corrected, replace "OUTPUT SPEED SENSOR" as necessary and go to "Verification of Vehicle Repair" procedure.

NO

Replace "TRANSMISSION RANGE SWITCH" as necessary and Go to "Verification of Vehicle Repair" procedure.

COMPONENT INSPECTION EBFAA523

CHECK TCM

1. Ignition "ON" & Engine "OFF".
2. Disconnect "C06-1/C106-1" connector.
3. Install scantool and select a SIMU-SCAN.
4. Simulate frequency to OUTPUT SPEED SENSOR signal circuit.

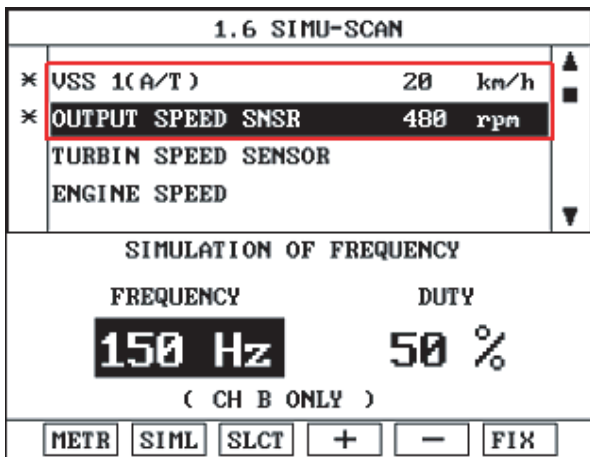

FIG.1)

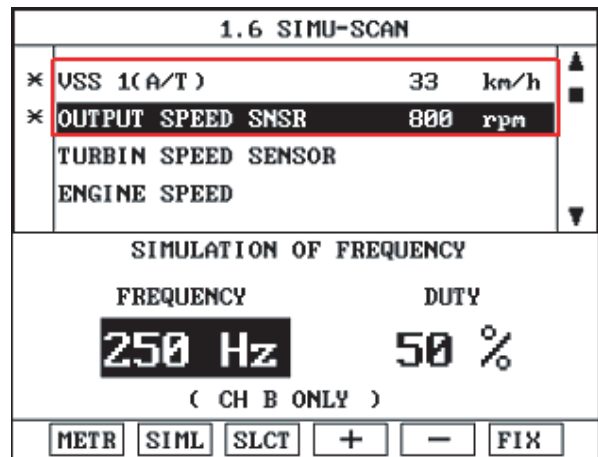

FIG.2)

FIG.1) INPUT 150HZ → 480rpm

FIG.2) INPUT 250HZ → 800rpm

※ The values are subject to change according to vehicle model or conditions.

5. Is "OUTPUT SPEED SENSOR" signal value changed according to simulation frequency?

YES

Thoroughly check connectors for looseness, poor connection, bending, corrosion, contamination, deterioration, or damage. Repair or replace as necessary and then go to "Verification of Vehicle Repair" procedure.

NO

Substitute with a known-good TCM and check for proper operation. If the problem is corrected, replace TCM as necessary and go to "Verification of Vehicle Repair" procedure.

VERIFICATION OF VEHICLE REPAIR EC146A6C

After a repair, it is essential to verify that the fault has been corrected.

1. Connect scantool and select "Diagnostic Trouble Codes(DTCs)" mode.
2. Using a scantool, Clear DTC.
3. Operate the vehicle within DTC Enable conditions in General information.
4. Are any DTCs present?

YES

Go to the applicable troubleshooting procedure.

NO

System performing to specification at this time.

DTC P0731 GEAR 1 INCORRECT RATIO

COMPONENT LOCATION EA6FE550

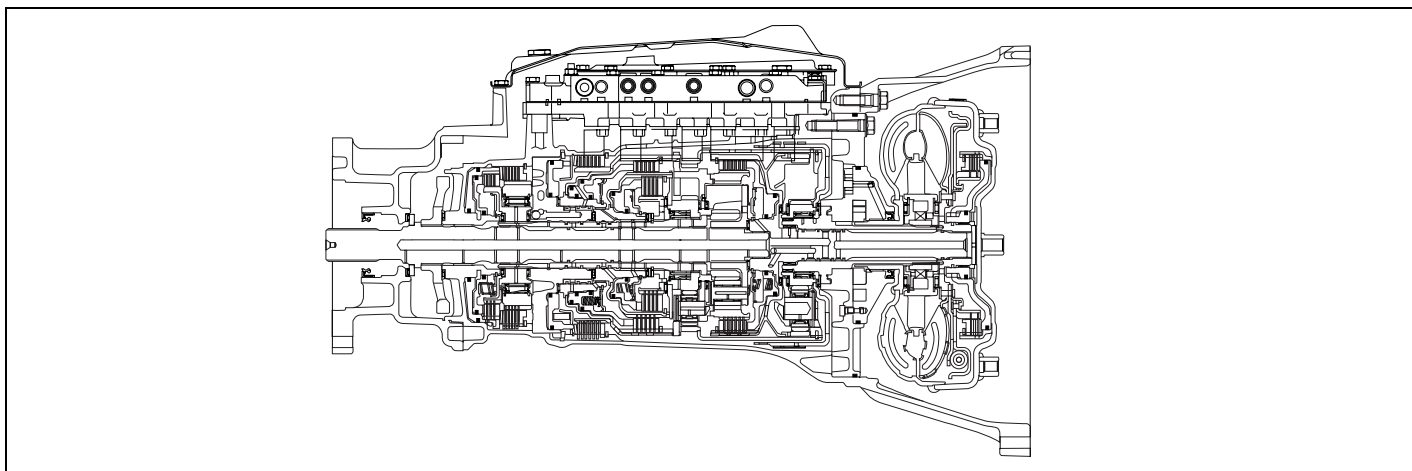

SBLAT6210L

GENERAL DESCRIPTION EADAED55

The value of the input shaft speed should be equal to the value of the output shaft speed, when multiplied by the 1st gear ratio, while the transaxle is engaged in the 1st gear. For example, if the output speed is 1000 rpm and the 1st gear ratio is 3.827, then the input speed is 3827 rpm.

DTC DESCRIPTION EE85EBBB

This code is set if the value of input shaft speed is not equal to the value of the output shaft, when multiplied by the 1st gear ratio, while the transaxle is engaged in 1st gear. This malfunction is mainly caused by mechanical troubles such as control valve sticking or solenoid valve malfunctioning rather than an electrical issue.

DTC DETECTING CONDITION E5009A92

Item	Detecting Condition	Possible cause
DTC Strategy	<ul style="list-style-type: none">• 1st gear incorrect ratio	<ul style="list-style-type: none">• Faulty input speed sensor• Faulty output speed sensor• Faulty inside transmission element
Enable Conditions	<ul style="list-style-type: none">• Engine speed > 600rpm• 150rpm > Output speed < 6000rpm• Lever Position = "D"• Input speed > 600rpm• A/T oil temp output -10°C• Throttle opening > 15%• The time after the last shift was finish > 1sec	
Threshold value	<ul style="list-style-type: none">• Input speed - output speed × 1st gear ratio 200rpm	
Diagnostic Time	<ul style="list-style-type: none">• More than 1sec	
Fail Safe	<ul style="list-style-type: none">• 4th gear Limp-Home mode	

SIGNAL WAVEFORM EADA829C

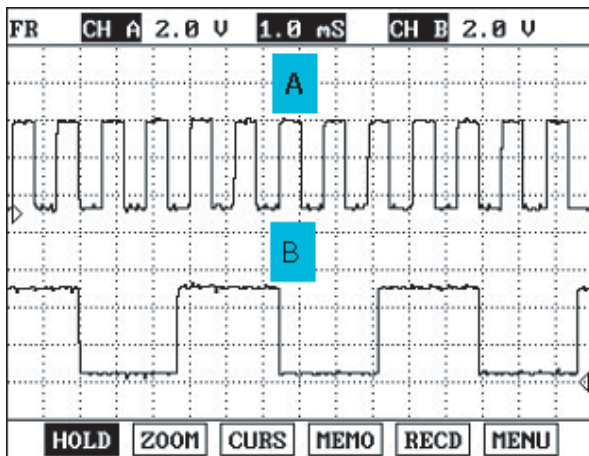

FIG.1)

A : INPUT SPEED SENSOR
B : OUTPUT SPEED SENSOR

SBLAT6211L

MONITOR SCANTOOL DATA EE18F60D

1. Connect scantool to data link connector(DLC).
2. Engine "ON".
3. Monitor the "ENGINE SPEED, INPUT SPEED SENSOR, OUTPUT SPEED SENSOR, GEAR POSITION" parameter on the scantool.
4. Perform the "STALL TEST" with gear position "1"

Specification : 2300 ± 200 engine rpm

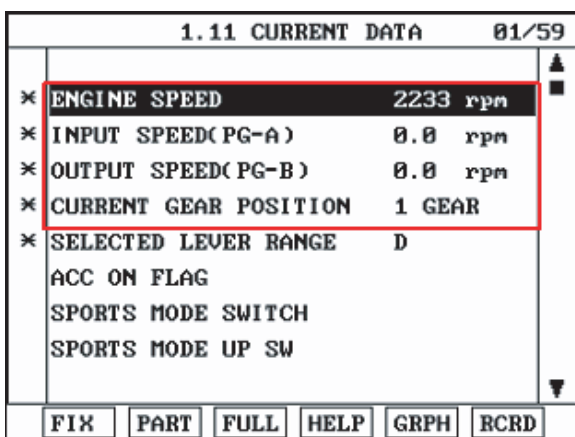

SBLAT6212L

OPERATING ELEMENT OF EACH SHIFTING RANGE

Shifting Position	Input clutch	High&Low Reverse Clutch	Direct clutch	Reverse Brake	Front Brake	Low Coast Brake	Forward Brake	1st OwnWayClutch	Forward OwnWayClutch	3rd OwnWayClutch
P		▲			▲					
R		●		●	●			●		●
N		▲			▲	★				
D	1st gear	★			▲		●	●	●	●
	2nd gear		●		▲		●		●	●
	3rd gear	●	●		●		▲	◆		●
	4th gear	●	●	●			▲	◆		
	5th gear	●	●			●	▲	◆		◆

● : WORKING.

◆ : PARTICIPATE IN DELIVERY TORQUE WHEN COAST DRIVING.

▲ : SUPPLING OIL PRESSURE TO ELEMENT, BUT NOT EFFECT ON OUTPUT.

★ : TEMPORARY WORKING.

SBLAT6213L

Stall test procedure in D1 and reason

Procedure

1. Warm up the engine
2. After positioning the select lever in "D", depress the foot brake pedal fully. After that, depress the accelerator pedal to the maximum

* The slippage of 1st gear operating parts can be detected by stall test in D

Reason for stall test

1. If there is no mechanical defaults in A/T, all slippage occurs in the torque converter.
2. Therefore, engine revolution is output, but input and output speed revolution must be "zero" due to wheel's lock.
3. If 1st gear operating parts have faults, input speed revolution will be out of specification.
4. If output speed revolution is output. It means that the foot brake force is not applied fully. Remeasuring is required.

5. Is "STALL TEST " within specification?

YES

Go to "Signal Circuit Inspection" procedure.

NO

Go to "Component inspection" procedure.

⚠ CAUTION

Do not let anybody stand in front of or behind the vehicle while this test is being carried out. Check the A/T fluid level and temperature and the engine coolant temperature.

- *Fluid level : At the hot mark on the oil level gauge.*
- *Fluid temperature : 176 °F~ 212 °F (80~100 °C).*
- *Engine coolant temperature : 176 °F~ 212 °F (80~100 °C).*

Chock both rear wheels(left and right).

Pull the parking brake lever on with the brake pedal fully depressed.

The throttle should not be left fully open for more than eight seconds.

If carrying out the stall test two or more times, move the select lever to the "N" position and run the engine at 1,000 rpm to let the A/T fluid cool down before carrying out subsequent tests.

SIGNAL CIRCUIT INSPECTION EC2F6D2D

1. Connect Scantool.
2. Engine "ON".
3. Monitor the "INPUT & OUTPUT SPEED SENSOR" parameter on the scantool.
4. Accelerate the Engine speed until about 2000 rpm in the 1st gear.

Specification : INPUT SPEED - (OUTPUT SPEED × 1st GEAR RATIO) 200 RPM

1.11 CURRENT DATA		01/59
× ENGINE SPEED	2044 rpm	
× INPUT SPEED(PG-A)	2050.rpm	
× TURBIN SPEED SENDOR 1	0.0 rpm	
× TURBIN SPEED SENDOR 2	2070.rpm	
× OUTPUT SPEED(PG-B)	544.0rpm	
× CURRENT GEAR POSITION	1 GEAR	
× SELECTED LEVER RANGE	D	
INHIBITOR SWITCH 1		

FIX PART FULL HELP GRPH RCRD

SBLAT6214L

5. Does "INPUT & OUTPUT SPEED SENSOR" within specifications?

YES

Go to "Component Inspection" procedure.

NO

Check for electrical noise of circuit in INPUT & OUTPUT SPEED SENSOR or replace INPUT & OUTPUT SPEED SENSOR. Repair as necessary and go to "Verification of Vehicle Repair" procedure.

COMPONENT INSPECTION EFAF5E2F

1. Connect Scantool.
2. Engine "ON".
3. Monitor the "OIL PRESSURE. S/W 1,2,3,5,6" parameter on the scantool.
4. Move select lever to "D" range and operate vehicle within 1st gear condition.

Shift position		Oil Pressure Switch				
		I/C(SW3)	H & LR/C(SW6)	H & LR/C(SW6)	FR/B(SW1)	LC/B(SW2)
P		X	O	X	O	X
R		X	O	X	O	X
N		X	O	X	O	X
D	1st gear	X	X	X	O	X
	2nd gear	X	X	O	O	X
	3rd gear	X	O	O	O	X
	4th gear	O	O	O	X	X
	5th gear	O	O	X	O	X

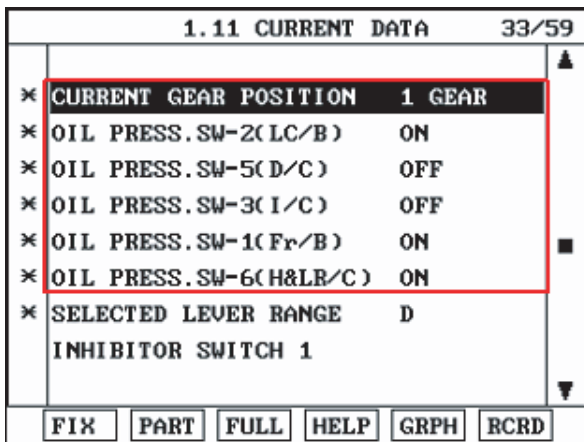

SBLAT6216L

5. Does "OIL PRESSURE. S/W 1,2,3,5,6 " follow the reference data?

YES

Repair AUTO TRANSAXLE(Clutch or Brake) as necessary and Go to "Verification of Vehicle Repair" procedure.

NO

Replace AUTO TRANSAXLE (BODY CONTROL VALVE faulty) as necessary and go to "Verification of Vehicle Repair " procedure.

VERIFICATION OF VEHICLE REPAIR ED60FCCF

After a repair, it is essential to verify that the fault has been corrected.

1. Connect scan tool and select "Diagnostic Trouble Codes(DTCs)" mode.
2. Using a scantool, Clear DTC.
3. Operate the vehicle within DTC Enable conditions in general information.
4. Are any DTCs present ?

YES

Go to the applicable troubleshooting procedure.

NO

System performing to specification at this time.

DTC P0732 GEAR 2 INCORRECT RATIO

COMPONENT LOCATION EEBC4CC1

Refer to DTC P0731.

GENERAL DESCRIPTION EEA5DCDF

The value of the input shaft speed should be equal to the value of the output shaft speed, when multiplied by the 2nd gear ratio, while the transaxle is engaged in the 2nd gear. For example, if the output speed is 1000 rpm and the 2nd gear ratio is 2.368, then the input speed is 2368 rpm.

DTC DESCRIPTION EDDF71B5

This code is set if the value of input shaft speed is not equal to the value of the output shaft, when multiplied by the 2nd gear ratio, while the transaxle is engaged in 2nd gear. This malfunction is mainly caused by mechanical troubles such as control valve sticking or solenoid valve malfunctioning rather than an electrical issue.

DTC DETECTING CONDITION E08BCE29

Item	Detecting Condition	Possible cause
DTC Strategy	<ul style="list-style-type: none">• 2nd gear incorrect ratio	<ul style="list-style-type: none">• Faulty input speed sensor• Faulty output speed sensor• Faulty inside transmission element
Enable Conditions	<ul style="list-style-type: none">• Engine speed > 600rpm• 150rpm > Output speed < 6000rpm• Lever Position = "D"• Input speed > 600rpm• A/T oil temp output -10°C• Throttle opening > 15%• The time after the last shift was finish > 1sec	
Threshold value	<ul style="list-style-type: none">• Input speed - output speed × 2nd gear ratio 200rpm	
Diagnostic Time	<ul style="list-style-type: none">• More than 1sec	
Fail Safe	<ul style="list-style-type: none">• 4th gear Limp-Home mode	

SIGNAL WAVEFORM EBC9ECA5

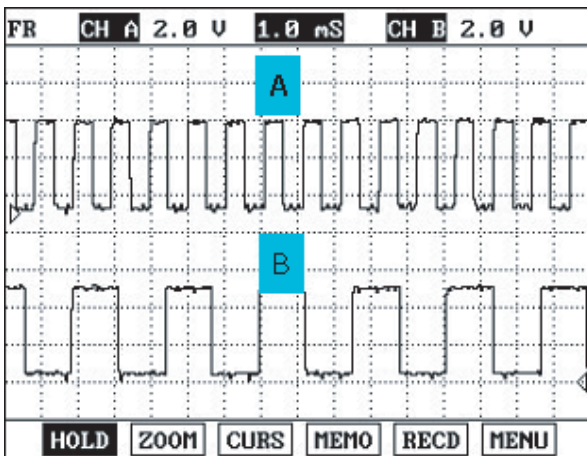

FIG.1)

A : INPUT SPEED SENSOR
B : OUTPUT SPEED SENSOR

SBLAT6221L

MONITOR SCANTOOL DATA EFFC49FC

1. Connect scantool to data link connector(DLC).
2. Engine "ON".
3. Monitor the "ENGINE SPEED, INPUT SPEED SENSOR, OUTPUT SPEED SENSOR, GEAR POSITION" parameter on the scantool.
4. Perform the "STALL TEST" with gear position "2"

Specification : 2300 ± 200 engine rpm

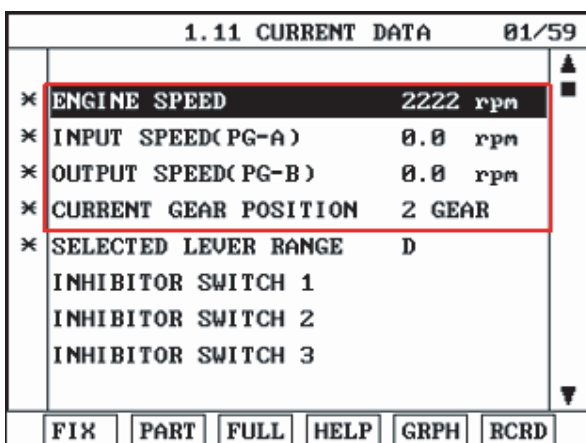

SBLAT6222L

OPERATING ELEMENT OF EACH SHIFTING RANGE

Shifting Position	Input clutch	High&Low Reverse Clutch	Direct clutch	Reverse Brake	Front Brake	Low Coast Brake	Forward Brake	1st OwnWayClutch	Forward OwnWayClutch	3rd OwnWayClutch
P		▲			▲					
R		●		●	●			●		●
N		▲			▲	★				
D	1st gear	★			▲		●	●	●	●
	2nd gear		●		▲		●		●	●
	3rd gear	●	●		●		▲	◆		●
	4th gear	●	●	●			▲	◆		
	5th gear	●	●			●	▲	◆		◆

● : WORKING.

◆ : PARTICIPATE IN DELIVERY TORQUE WHEN COAST DRIVING.

▲ : SUPPLING OIL PRESSURE TO ELEMENT, BUT NOT EFFECT ON OUTPUT.

★ : TEMPORARY WORKING.

SBLAT6213L

Stall test procedure in D2 and reason

Procedure

1. Warm up the engine
2. After positioning the select lever in "D", depress the foot brake pedal fully. After that, depress the accelerator pedal to the maximum

* The slippage of 2nd gear operating parts can be detected by stall test in D2

Reason for stall test

1. If there is no mechanical defaults in A/T, all slippage occurs in the torque converter.
2. Therefore, engine revolution is output, but input and output speed revolution must be "zero" due to wheel's lock.
3. If 2nd gear operating parts have faults, input speed revolution will be out.
4. If output speed revolution is output. It means that the foot brake force is not applied fully. Remeasuring is required.

5. Is "STALL TEST " within specification?

YES

Go to "Signal Circuit Inspection" procedure.

NO

Go to "Component inspection" procedure.

CAUTION

Do not let anybody stand in front of or behind the vehicle while this test is being carried out. Check the A/T fluid level and temperature and the engine coolant temperature.

- *Fluid level : At the hot mark on the oil level gauge.*
- *Fluid temperature : 176 °F~ 212 °F (80~100 °C).*
- *Engine coolant temperature : 176 °F~ 212 °F (80~100 °C).*

Chock both rear wheels(left and right).

Pull the parking brake lever on with the brake pedal fully depressed.

The throttle should not be left fully open for more than eight seconds.

If carrying out the stall test two or more times, move the select lever to the "N" position and run the engine at 1,000 rpm to let the A/T fluid cool down before carrying out subsequent tests.

SIGNAL CIRCUIT INSPECTION E2EA6E31

1. Connect Scantool.
2. Engine "ON".
3. Monitor the "INPUT & OUTPUT SPEED SENSOR" parameter on the scantool.
4. Accelerate the Engine speed until about 2000 rpm in the 2nd gear.

Specification : INPUT SPEED - (OUTPUT SPEED × 2nd GEAR RATIO) 200 RPM

1.11 CURRENT DATA		01/59
× ENGINE SPEED	1975 rpm	
× INPUT SPEED(PG-A)	1953. rpm	
× TURBIN SPEED SENDOR 1	0.0 rpm	
× TURBIN SPEED SENDOR 2	1939. rpm	
× OUTPUT SPEED(PG-B)	817.0rpm	
× CURRENT GEAR POSITION	2 GEAR	
× SELECTED LEVER RANGE	D	
INHIBITOR SWITCH 1		

SBLAT6224L

5. Does "INPUT & OUTPUT SPEED SENSOR" within specifications?

YES

Go to "Component Inspection" procedure.

NO

Check for electrical noise of circuit in INPUT & OUTPUT SPEED SENSOR or replace INPUT & OUTPUT SPEED SENSOR. Repair as necessary and go to "Verification of Vehicle Repair" procedure.

COMPONENT INSPECTION EA3FA4DF

1. Connect Scantool.
2. Engine "ON".
3. Monitor the "OIL PRESSURE. S/W 1,2,3,5,6" parameter on the scantool.
4. Move select lever to "D" range and operate vehicle within 2nd gear condition.

Shift position		Oil Pressure Switch				
		I/C(SW3)	H & LR/C(SW6)	H & LR/C(SW6)	FR/B(SW1)	LC/B(SW2)
P		X	O	X	O	X
R		X	O	X	O	X
N		X	O	X	O	X
D	1st gear	X	X	X	O	X
	2nd gear	X	X	O	O	X
	3rd gear	X	O	O	O	X
	4th gear	O	O	O	X	X
	5th gear	O	O	X	O	X

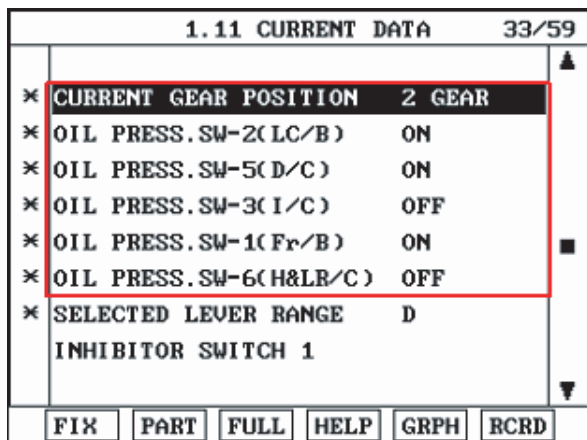

SBLAT6226L

5. Is oil pressure value within specifications?

YES

Repair AUTO TRANSAXLE(Clutch or Brake) as necessary and Go to "Verification of Vehicle Repair" procedure.

NO

Replace AUTO TRANSAXLE (BODY CONTROL VALVE faulty) as necessary and go to "Verification of Vehicle Repair " procedure.

VERIFICATION OF VEHICLE REPAIR EC89F2AB

Refer to DTC P0731.

DTC P0733 GEAR 3 INCORRECT RATIO

COMPONENT LOCATION E1416B7E

Refer to DTC P0731.

GENERAL DESCRIPTION E4992E3F

The value of the input shaft speed should be equal to the value of the output shaft speed, when multiplied by the 3rd gear ratio, while the transaxle is engaged in the 3rd gear. For example, if the output speed is 1,000 rpm and the 3rd gear ratio is 1.520, then the input speed is 1520 rpm.

DTC DESCRIPTION EB54FE5F

This code is set if the value of input shaft speed is not equal to the value of the output shaft, when multiplied by the 3rd gear ratio, while the transaxle is engaged in 3rd gear. This malfunction is mainly caused by mechanical troubles such as control valve sticking or solenoid valve malfunctioning rather than an electrical issue.

DTC DETECTING CONDITION EE6E366A

Item	Detecting Condition	Possible cause
DTC Strategy	<ul style="list-style-type: none">• 3rd gear incorrect ratio	<ul style="list-style-type: none">• Faulty input speed sensor• Faulty output speed sensor• Faulty inside transmission element
Enable Conditions	<ul style="list-style-type: none">• Engine speed > 600rpm• 150rpm > Output speed < 6000rpm• Lever Position = "D"• Input speed > 600rpm• A/T oil temp output -10°C• Throttle opening > 15%• The time after the last shift was finish > 1sec	
Threshold value	<ul style="list-style-type: none">• Input speed - output speed × 3rd gear ratio 200rpm	
Diagnostic Time	<ul style="list-style-type: none">• More than 1sec	
Fail Safe	<ul style="list-style-type: none">• 4th gear Limp-Home mode	

SIGNAL WAVEFORM EA7B27E4

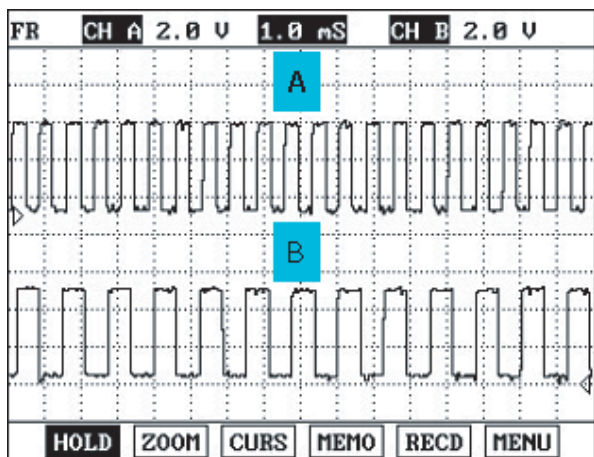

FIG.1)

A : INPUT SPEED SENSOR
B : OUTPUT SPEED SENSOR

SBLAT6231L

SIGNAL CIRCUIT INSPECTION ECBFCD4A

1. Connect Scantool.
2. Engine "ON".
3. Monitor the "INPUT & OUTPUT SPEED SENSOR" parameter on the scantool.
4. Accelerate the Engine speed until about 2000 rpm in the 3rd gear.

Specification : INPUT SPEED - (OUTPUT SPEED × 3rd GEAR RATIO) 200 RPM

1.11 CURRENT DATA		01/59
× ENGINE SPEED	2015 rpm	
× INPUT SPEED(PG-A)	1996. rpm	
× TURBIN SPEED SENDOR 1	0.0 rpm	
× TURBIN SPEED SENDOR 2	1990. rpm	
× OUTPUT SPEED(PG-B)	1311. rpm	
× CURRENT GEAR POSITION	3 GEAR	
× SELECTED LEVER RANGE	D	
INHIBITOR SWITCH 1		

FIX PART FULL HELP GRPH RCRD

SBLAT6232L

AUTOMATIC TRANSAXLE SYSTEM

5. Does "INPUT & OUTPUT SPEED SENSOR" within specifications?

YES

Go to "Component Inspection" procedure.

NO

Check for electrical noise of circuit in INPUT & OUTPUT SPEED SENSOR or replace INPUT & OUTPUT SPEED SENSOR. Repair as necessary and go to "Verification of Vehicle Repair" procedure.

COMPONENT INSPECTION

E19E7130

1. Connect Scantool.
2. Engine "ON".
3. Monitor the "OIL PRESSURE. S/W 1,2,3,5,6" parameter on the scantool.
4. Move select lever to "D" range and operate vehicle within 3rd gear condition.

Shift position	Oil Pressure Switch					
	I/C(SW3)	H & LR/C(SW6)	H & LR/C(SW6)	FR/B(SW1)	LC/B(SW2)	
P	X	O	X	O	X	
R	X	O	X	O	X	
N	X	O	X	O	X	
D	1st gear	X	X	X	O	X
	2nd gear	X	X	O	O	X
	3rd gear	X	O	O	O	X
	4th gear	O	O	O	X	X
	5th gear	O	O	X	O	X

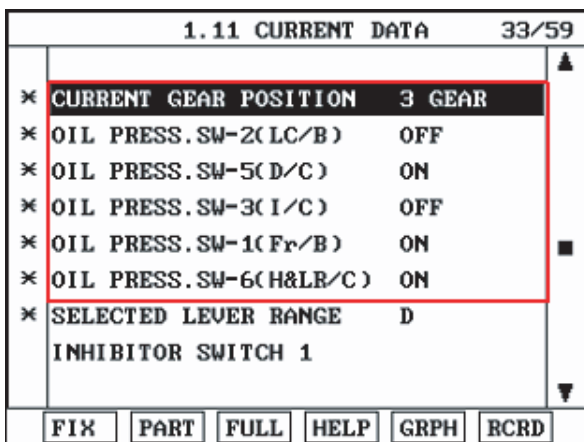

5. Is oil pressure value within specifications?

YES

Repair AUTO TRANSAXLE(Clutch or Brake) as necessary and Go to "Verification of Vehicle Repair" procedure.

NO

Replace AUTO TRANSAXLE (BODY CONTROL VALVE faulty) as necessary and go to "Verification of Vehicle Repair" procedure.

VERIFICATION OF VEHICLE REPAIR E3EE0C3B

Refer to DTC P0731.

DTC P0734 GEAR 4 INCORRECT RATIO

COMPONENT LOCATION E0D64D2E

Refer to DTC P0731.

GENERAL DESCRIPTION E06C48DB

The value of the input shaft speed should be equal to the value of the output shaft speed, when multiplied by the 4th gear ratio, while the transaxle is engaged in the 4th gear. For example, if the output speed is 1,000 rpm and the 4th gear ratio is 1.000, then the input speed is 1000 rpm.

DTC DESCRIPTION E62C6B75

This code is set if the value of input shaft speed is not equal to the value of the output shaft, when multiplied by the 4th gear ratio, while the transaxle is engaged in 4th gear. This malfunction is mainly caused by mechanical troubles such as control valve sticking or solenoid valve malfunctioning rather than an electrical issue.

DTC DETECTING CONDITION E2B814E9

Item	Detecting Condition	Possible cause
DTC Strategy	<ul style="list-style-type: none">• 4th gear incorrect ratio	<ul style="list-style-type: none">• Faulty input speed sensor• Faulty output speed sensor• Faulty inside transmission element
Enable Conditions	<ul style="list-style-type: none">• Engine speed > 600rpm• 150rpm > Output speed < 6000rpm• Lever Position = "D"• Input speed > 600rpm• A/T oil temp output -10°C• Throttle opening > 15%• The time after the last shift was finish > 1sec	
Threshold value	<ul style="list-style-type: none">• Input speed - output speed × 4th gear ratio 200rpm	
Diagnostic Time	<ul style="list-style-type: none">• More than 1sec	
Fail Safe	<ul style="list-style-type: none">• 4th gear Limp-Home mode	

SIGNAL WAVEFORM EC042485

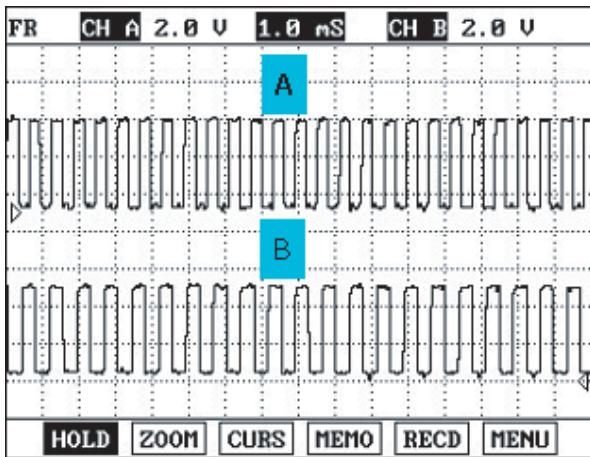

FIG.1)

A : INPUT SPEED SENSOR
B : OUTPUT SPEED SENSOR

SBLAT6241L

MONITOR SCANTOOL DATA E47CB401

1. Connect scantool to data link connector(DLC).
2. Engine "ON".
3. Monitor the "ENGINE SPEED, INPUT SPEED SENSOR, OUTPUT SPEED SENSOR, GEAR POSITION" parameter on the scantool.
4. Perform the "STALL TEST" with gear position "4"

Specification : 2300 ± 200 engine rpm

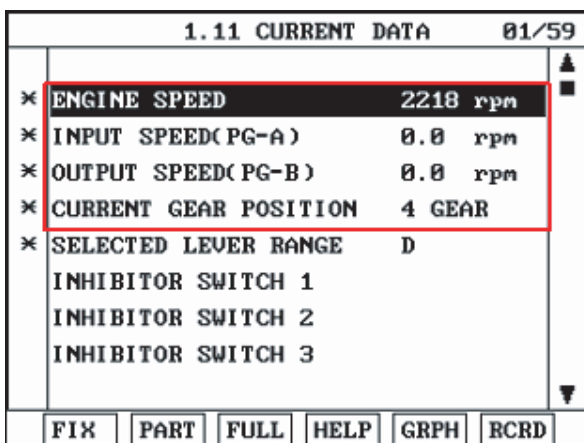

SBLAT6242L

OPERATING ELEMENT OF EACH SHIFTING RANGE

Shifting Position	Input clutch	High&Low Reverse Clutch	Direct clutch	Reverse Brake	Front Brake	Low Coast Brake	Forward Brake	1st OwnWayClutch	Forward OwnWayClutch	3rd OwnWayClutch
P		▲			▲					
R		●		●	●			●		●
N		▲			▲	★				
D	1st gear	★			▲		●	●	●	●
	2nd gear		●		▲		●		●	●
	3rd gear		●	●	●		▲	◆		●
	4th gear	●	●	●			▲	◆		
	5th gear	●	●			●		▲	◆	◆

- : WORKING.
- ◆ : PARTICIPATE IN DELIVERY TORQUE WHEN COAST DRIVING.
- ▲ : SUPPLING OIL PRESSURE TO ELEMENT, BUT NOT EFFECT ON OUTPUT.
- ★: TEMPORARY WORKING.

SBLAT6213L

Stall test procedure in D4 and reason

Procedure

1. Warm up the engine
2. After positioning the select lever in "D" or "ON" of the HOLD SW (Operate UP SHIFT in case of "SPORTS MODE"),depress the foot brake pedal fully after that, depress the accelerator pedal to the maximum.

* The slippage of 4th gear operating parts can be detected by stall test in D4

Reason for stall test

1. If there is no mechanical defaults in A/T, all slippage occurs in the torque converter.
2. Therefore, engine revolution is output, but input and output speed revolution must be "zero" due to wheel's lock.
3. If 4th gear operating parts have faults, input speed revolution will be out.
4. If output speed revolution is output. It means that the foot brake force is not applied fully. Remeasuring is required.

5. Is "STALL TEST " within specification?

YES

Go to "Signal Circuit Inspection" procedure.

NO

Go to "Component inspection" procedure.

 **CAUTION**

*Do not let anybody stand in front of or behind the vehicle while this test is being carried out.
Check the A/T fluid level and temperature and the engine coolant temperature.*

- *Fluid level : At the hot mark on the oil level gauge.*
- *Fluid temperature : 176 °F~ 212 °F (80~100 °C).*
- *Engine coolant temperature : 176 °F~ 212 °F (80~100 °C).*

Chock both rear wheels(left and right).

Pull the parking brake lever on with the brake pedal fully depressed.

The throttle should not be left fully open for more than eight seconds.

If carrying out the stall test two or more times, move the select lever to the "N" position and run the engine at 1,000 rpm to let the A/T fluid cool down before carrying out subsequent tests.

SIGNAL CIRCUIT INSPECTION E5D1EB2B

1. Connect Scantool.
2. Engine "ON".
3. Monitor the "INPUT & OUTPUT SPEED SENSOR" parameter on the scantool.
4. Accelerate the Engine speed until about 2000 rpm in the 4th gear.

Specification : INPUT SPEED - (OUTPUT SPEED × 4th GEAR RATIO) 200 RPM

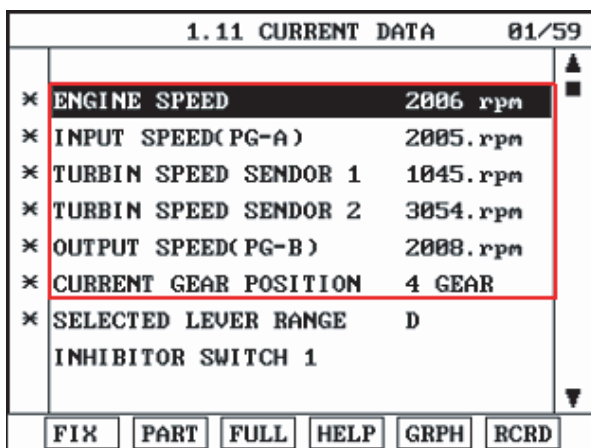

1.11 CURRENT DATA		01/59
* ENGINE SPEED	2006 rpm	
* INPUT SPEED(PG-A)	2005. rpm	
* TURBIN SPEED SENDOR 1	1045. rpm	
* TURBIN SPEED SENDOR 2	3054. rpm	
* OUTPUT SPEED(PG-B)	2008. rpm	
* CURRENT GEAR POSITION	4 GEAR	
* SELECTED LEVER RANGE	D	
INHIBITOR SWITCH 1		

FIX PART FULL HELP GRPH RCRD

SBLAT6244L

5. Does "INPUT & OUTPUT SPEED SENSOR" within specifications?

YES

Go to "Component Inspection" procedure.

NO

Check for electrical noise of circuit in INPUT & OUTPUT SPEED SENSOR or replace INPUT & OUTPUT SPEED SENSOR. Repair as necessary and go to "Verification of Vehicle Repair" procedure.

AUTOMATIC TRANSAXLE SYSTEM

COMPONENT INSPECTION ECBA4DDA

1. Connect Scantool.
2. Engine "ON".
3. Monitor the "OIL PRESSURE. S/W 1,2,3,5,6" parameter on the scantool.
4. Move select lever to "D" range and operate vehicle within 4th gear condition.

Shift position		Oil Pressure Switch				
		I/C(SW3)	H & LR/C(SW6)	H & LR/C(SW6)	FR/B(SW1)	LC/B(SW2)
P		X	O	X	O	X
R		X	O	X	O	X
N		X	O	X	O	X
D	1st gear	X	X	X	O	X
	2nd gear	X	X	O	O	X
	3rd gear	X	O	O	O	X
	4th gear	O	O	O	X	X
	5th gear	O	O	X	O	X

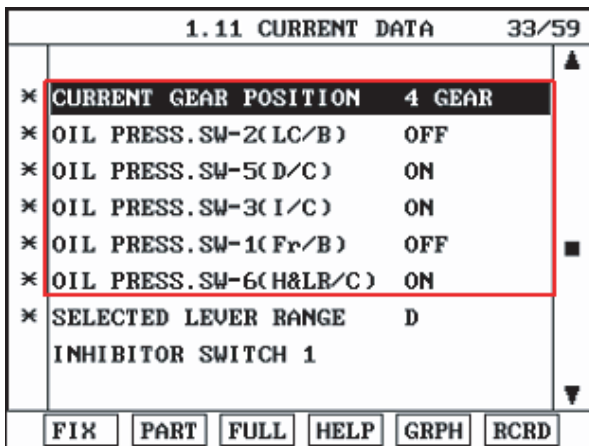

SBLAT6246L

5. Is oil pressure value within specifications?

YES

Repair AUTO TRANSAXLE(Clutch or Brake) as necessary and Go to "Verification of Vehicle Repair" procedure.

NO

Replace AUTO TRANSAXLE (BODY CONTROL VALVE faulty) as necessary and go to "Verification of Vehicle Repair" procedure.

VERIFICATION OF VEHICLE REPAIR EB85B35F

Refer to DTC P0731.

DTC P0735 GEAR 5 INCORRECT RATIO

COMPONENT LOCATION E4CF3ACE

Refer to DTC P0731.

GENERAL DESCRIPTION EBA8E7AA

The value of the input shaft speed should be equal to the value of the output shaft speed, when multiplied by the 5th gear ratio, while the transaxle is engaged in the 5th gear. For example, if the output speed is 1,000 rpm and the 5th gear ratio is 0.834, then the input speed is 834 rpm.

DTC DESCRIPTION E9A6FA8B

This code is set if the value of input shaft speed is not equal to the value of the output shaft, when multiplied by the 5th gear ratio, while the transaxle is engaged in 5th gear. This malfunction is mainly caused by mechanical troubles such as control valve sticking or solenoid valve malfunctioning rather than an electrical issue.

DTC DETECTING CONDITION EF0616A0

Item	Detecting Condition	Possible cause
DTC Strategy	<ul style="list-style-type: none">• 5th gear incorrect ratio	<ul style="list-style-type: none">• Faulty input speed sensor• Faulty output speed sensor• Faulty inside transmission element
Enable Conditions	<ul style="list-style-type: none">• Engine speed > 600rpm• 150rpm > Output speed < 6000rpm• Lever Position = "D"• Input speed > 600rpm• A/T oil temp output -10°C• Throttle opening > 15%• The time after the last shift was finish > 1sec	
Threshold value	<ul style="list-style-type: none">• Input speed - output speed × 5th gear ratio 200rpm	
Diagnostic Time	<ul style="list-style-type: none">• More than 1sec	
Fail Safe	<ul style="list-style-type: none">• 4th gear Limp-Home mode	

SIGNAL WAVEFORM EDE87ABE

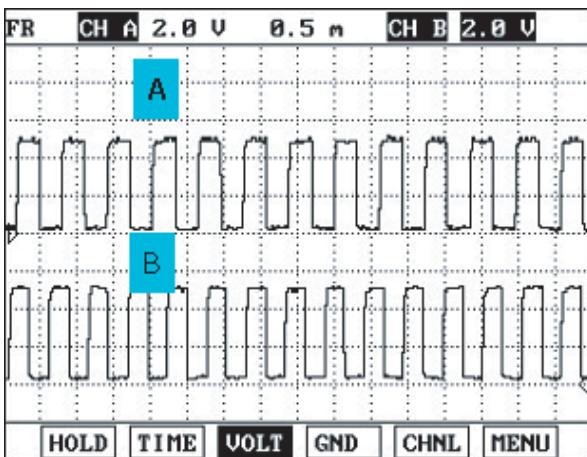

FIG.1)

A : INPUT SPEED SENSOR
B : OUTPUT SPEED SENSOR

SBLAT6251L

SIGNAL CIRCUIT INSPECTION EAABDA2A

1. Connect Scantool.
2. Engine "ON".
3. Monitor the "INPUT & OUTPUT SPEED SENSOR" parameter on the scantool.
4. Accelerate the Engine speed until about 2000 rpm in the 5th gear.

Specification : INPUT SPEED - (OUTPUT SPEED × 5th GEAR RATIO) 200 RPM

1.11 CURRENT DATA		01/59
×	ENGINE SPEED	1972 rpm
×	INPUT SPEED(PG-A)	1972.rpm
×	TURBIN SPEED SENDOR 1	0.0 rpm
×	TURBIN SPEED SENDOR 2	1973.rpm
×	OUTPUT SPEED(PG-B)	2370.rpm
×	CURRENT GEAR POSITION	5 GEAR
×	SELECTED LEVER RANGE	D
	INHIBITOR SWITCH 1	

FIX PART FULL HELP GRPH RCRD

SBLAT6252L

5. Does "INPUT & OUTPUT SPEED SENSOR" within specifications?

YES

Go to "Component Inspection" procedure.

NO

Check for electrical noise of circuit in INPUT & OUTPUT SPEED SENSOR or replace INPUT & OUTPUT SPEED SENSOR. Repair as necessary and go to "Verification of Vehicle Repair" procedure.

COMPONENT INSPECTION EEBEEAFA

1. Connect Scantool.
2. Engine "ON".
3. Monitor the "OIL PRESSURE. S/W 1,2,3,5,6" parameter on the scantool.
4. Move select lever to "D" range and operate vehicle within 5th gear condition.

Shift position	Oil Pressure Switch					
	I/C(SW3)	H & LR/C(SW6)	H & LR/C(SW6)	FR/B(SW1)	LC/B(SW2)	
P	X	O	X	O	X	
R	X	O	X	O	X	
N	X	O	X	O	X	
D	1st gear	X	X	X	O	X
	2nd gear	X	X	O	O	X
	3rd gear	X	O	O	O	X
	4th gear	O	O	O	X	X
	5th gear	O	O	X	O	X

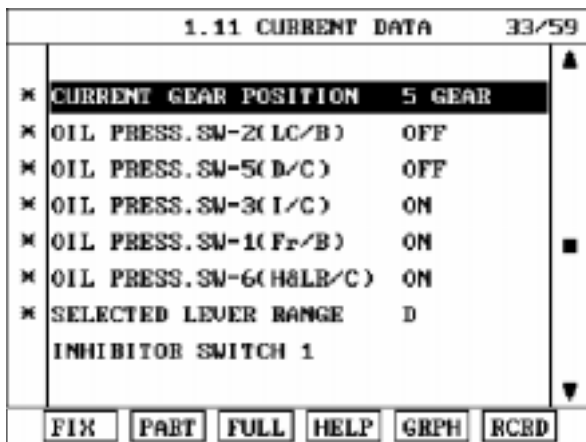

5. Is oil pressure value within specifications?

YES

Repair AUTO TRANSAXLE(Clutch or Brake) as necessary and Go to "Verification of Vehicle Repair" procedure.

NO

Replace AUTO TRANSAXLE (BODY CONTROL VALVE faulty) as necessary and go to "Verification of Vehicle Repair" procedure.

VERIFICATION OF VEHICLE REPAIR EFD7A16E

Refer to DTC P0731.

DTC P0741 TORQUE CONVERTER CLUTCH CIRCUIT - STUCK OFF

COMPONENT LOCATION E0DEDAD0

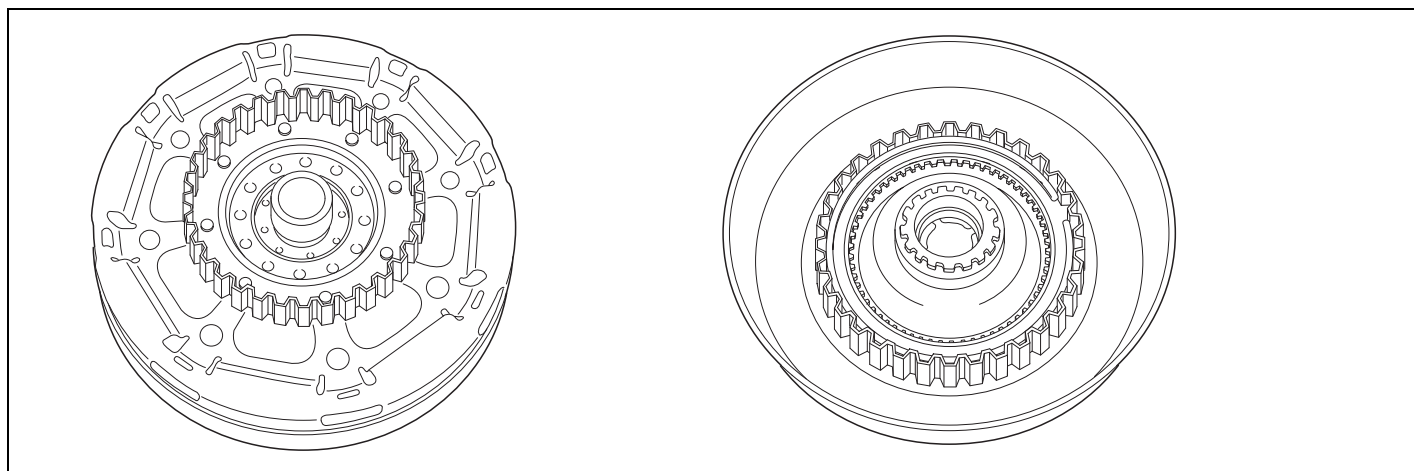

SBLAT6140L

GENERAL DESCRIPTION EAADC733

The PCM/TCM controls the locking and unlocking of the Torque Converter Clutch (or Damper Clutch), to the input shaft of the transmission, by applying hydraulic pressure. The main purpose of T/C clutch control is to save fuel by decreasing the hydraulic load inside the T/C. The TCM outputs duty pulses to control the Damper Clutch Control Solenoid Valve(DCCSV) and hydraulic pressure is applied to DC according to the DCC duty ratio value.

When the duty ratio is high, high pressure is applied and the Damper Clutch is locked. The normal operating range of the Damper Clutch Control current is from 0.05A(unlocked) to 0.75A(locked).

DTC DESCRIPTION ECDE68D4

The PCM/TCM increases the duty ratio to engage the Damper Clutch by monitoring slip rpms (difference vlaue between engine speed and turbine speed).

To decrease the slip of the Damper Clutch, the TCM increases the duty ratio by applying more hyraulic pressure.

When slip rpm does not drop under some value with 100% duty ratio, the PCM/TCM determines that the Torque Converter Clutch is stuck OFF and sets this code.

AUTOMATIC TRANSAXLE SYSTEM

DTC DETECTING CONDITION ED8EACE0

[DSL 2.5]

Item		Detecting Condition	Possible cause
DTC Strategy		<ul style="list-style-type: none"> Stuck "OFF" 	TORQUE CONVERTER (DAMPER) CLUTCH : TCC <ul style="list-style-type: none"> Faulty TCC or oil pressure system Faulty TCC solenoid valve Faulty body control valve Faulty TCM
Enable Conditions	case1	<ul style="list-style-type: none"> Vehicle speed 6.2MPH(10km/h) Engine speed > 305 rpm A/T range switch is D range 68°F A/T fluid temperature 212°F 	
	case2	<ul style="list-style-type: none"> Vehicle speed 6.2MPH(10km/h) Engine speed > 305 rpm A/T range switch is D range 68°F A/T fluid temperature 212°F 	
Threshold Value	case1	<ul style="list-style-type: none"> Calculated slip (engine speed-input speed) > 40rpm+Vsp1/2 at 5th gear full lock up 	
	case2	<ul style="list-style-type: none"> Calculated slip (engine speed-input speed) Target slip speed+65rpm at 4th, 5th gear slip lock up 	
Diagnostic Time		<ul style="list-style-type: none"> more than 30sec 	
Fail Safe		<ul style="list-style-type: none"> Lock-up control is prohibited Slip lock-up control is prohibited 	

[GSL 3.3/3.8]

Item	Detecting Condition	Possible cause
DTC Strategy	<ul style="list-style-type: none"> Stuck "OFF" 	TORQUE CONVERTER(DAMPER) CLUTCH : TCC <ul style="list-style-type: none"> Faulty TCC or oil pressure system Faulty TCC solenoid valve Faulty body control valve Faulty TCM
Enable Conditions	<ul style="list-style-type: none"> Duty of "Damper clutch solenoid valve" = 100% Input speed > 0rpm 	
Threshold value	<ul style="list-style-type: none"> Calculated slip (engine speed-input speed) > 100rpm 	
Diagnostic Time	<ul style="list-style-type: none"> More than 5sec 	
Fail Safe	<ul style="list-style-type: none"> Damper clutch "OFF" 	

MONITOR SCANTOOL DATA E9A77934

1. Connect scantool to data link connector(DLC).
2. Engine "ON".
3. Select "D RANGE" and drive vehicle 5 gear.
4. Monitor the "TORQUE CONVERTER(DAMPER) CLUTCH" parameter on the scantool .

Specification :

[DSL 2.5]

TCC SLIP < 40RPM+ Vsp1/2(In condition that LU(TCC) SOL. current > 6.5A)

[GSL 3.3/3.8]

Calculated slip (engine speed-input speed) < 100rpm

[DSL 2.5]

1.3 CURRENT DATA		07/76
* TURBIN SPEED SENSOR	0 rpm	
* ENGINE SPEED	736 rpm	
* DAMPER CLUTCH SL. RPM	254 rpm	
* LU SOL. OUTPUT	0.01 A	
* LU SOL. MONITOR	0.00 A	
* CURRENT GEAR POS.	1 GEAR	
* SHIFT RANGE INDICATOR	D	
SELECTED LEVER RANGE		

FIX PART FULL HELP GRPH RCRD

FIG.1)

FIG.1) : Non-operating Lock-up Clutch



1.3 CURRENT DATA		07/76
* TURBIN SPEED SENSOR	2720 rpm	
* ENGINE SPEED	2720 rpm	
* DAMPER CLUTCH SL. RPM	0 rpm	
* LU SOL. OUTPUT	0.45 A	
* LU SOL. MONITOR	0.57 A	
* CURRENT GEAR POS.	4 GEAR	
* SHIFT RANGE INDICATOR	-	
SELECTED LEVER RANGE		

FIX PART FULL HELP GRPH RCRD

FIG.2)

FIG.2) : Operating Lock-up Clutch

SBLAT6141L

[GSL 3.3/3.8]

1.11 CURRENT DATA		89/59
ENGINE SPEED	721 rpm	
INPUT SPEED(PG-A)	781.8rpm	
TCC SLIP RPM	8.8 rpm	
TCCSV(LU)	8.8 %	
TCCSV CURRENT(LU)	48.8 mA	
TCCSV PRESSURE(LU)	-43.5psi	
CURRENT GEAR POSITION	P N	
SELECTED LEVER RANGE	N	

FIG.1)

1.11 CURRENT DATA		89/59
ENGINE SPEED	895 rpm	
INPUT SPEED(PG-A)	848.8rpm	
TCC SLIP RPM	53.8 rpm	
TCCSV(LU)	8.8 %	
TCCSV CURRENT(LU)	48.8 mA	
TCCSV PRESSURE(LU)	-43.5psi	
CURRENT GEAR POSITION	REVERSE	
SELECTED LEVER RANGE	R	

FIG.2)

1.11 CURRENT DATA		89/59
ENGINE SPEED	1839 rpm	
INPUT SPEED(PG-A)	1821.rpm	
TCC SLIP RPM	33.8 rpm	
TCCSV(LU)	8.8 %	
TCCSV CURRENT(LU)	48.8 mA	
TCCSV PRESSURE(LU)	-43.5psi	
CURRENT GEAR POSITION	1 GEAR	
SELECTED LEVER RANGE	D	

FIG.3)

1.11 CURRENT DATA		89/59
ENGINE SPEED	1668 rpm	
INPUT SPEED(PG-A)	1642.rpm	
TCC SLIP RPM	16.8 rpm	
TCCSV(LU)	8.8 %	
TCCSV CURRENT(LU)	48.8 mA	
TCCSV PRESSURE(LU)	-43.5psi	
CURRENT GEAR POSITION	2 GEAR	
SELECTED LEVER RANGE	D	

FIG.4)

1.11 CURRENT DATA		89/59
ENGINE SPEED	2335 rpm	
INPUT SPEED(PG-A)	2325.rpm	
TCC SLIP RPM	28.8 rpm	
TCCSV(LU)	8.8 %	
TCCSV CURRENT(LU)	48.8 mA	
TCCSV PRESSURE(LU)	-43.5psi	
CURRENT GEAR POSITION	3 GEAR	
SELECTED LEVER RANGE	D	

FIG.5)

1.11 CURRENT DATA		89/59
ENGINE SPEED	2293 rpm	
INPUT SPEED(PG-A)	2384.rpm	
TCC SLIP RPM	8.8 rpm	
TCCSV(LU)	38.4 %	
TCCSV CURRENT(LU)	388.8mA	
TCCSV PRESSURE(LU)	5.8 psi	
CURRENT GEAR POSITION	4 GEAR	
SELECTED LEVER RANGE	D	

FIG.6)

1.11 CURRENT DATA		89/59
ENGINE SPEED	2352 rpm	
INPUT SPEED(PG-A)	2353.rpm	
TCC SLIP RPM	8.8 rpm	
TCCSV(LU)	42.8 %	
TCCSV CURRENT(LU)	488.8mA	
TCCSV PRESSURE(LU)	18.1 psi	
CURRENT GEAR POSITION	5 GEAR	
SELECTED LEVER RANGE	D	

FIG.7)

- FIG.1) "P,N" range
- FIG.2) "R" range
- FIG.3) "D" range 1st gear
- FIG.4) "D" range 2nd gear
- FIG.5) "D" range 3rd gear
- FIG.6) "D" range 4th gear
- FIG.7) "D" range 5th gear

5. Is "TCC SLIP(DAMPER CLUTCH SL.RPM)" within specifications?

YES

Fault is intermittent caused by poor contact in the sensor's and/or PCM/TCM's connector or was repaired and PCM/TCM memory was not cleared. Thoroughly check connectors for looseness, poor connection, bending, corrosion, contamination, deterioration or damage.Repair or replace as necessary and go to "Verification of Vehicle Repair" procedure.

NO

Go to "Component Inspection" procedure.

COMPONENT INSPECTION EA9DAFCD

1. Disconnect "C06-2/C106-2" connector.
2. Ignition "OFF".
3. Measure resistance between terminal "9" of the C06-2/C106-2 harness connector and chassis ground.

Specification : approx. 3~9

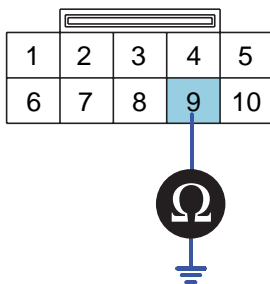

C06-2 [DSL 2.5]
C106-2 [GSL 3.3/3.8]
Component side

- 1.ATF 2
- 2.LOW COAST BRAKE SOLENOID VALVE
- 3.HIGH&LOW REVERSE CLUTCH SOLENOID VALVE
- 4.DIRECT CLUTCH SOLENOID VALVE
- 6.FRONT BRAKE SOLENOID VALVE
- 7.INPUT CLUTCH SOLENOID VALVE
- 8.PCSV(LINE PRESSURE CONTROL SOLENOID VALVE)
- 9.TCCSV

SBLAT6142L

4. Is resistance within specifications?

YES

Repair TORQUE CONVERTER CLUTCH(REPLACE Torque Converter) as necessary and Go to "Verification of Vehicle Repair" procedure.

NO

Replace A/T assembly (possible to BODY CONTROL VALVE faulty) as necessary and Go to "Verification of Vehicle Repair" procedure.

VERIFICATION OF VEHICLE REPAIR E14181F8

After a repair, it is essential to verify that the fault has been corrected.

1. Connect scantool and select "Diagnostic Trouble Codes(DTCs)" mode.
2. Using a scantool, Clear DTC.
3. Operate the vehicle within DTC Enable conditions in General information.
4. Are any DTCs present?

YES

Go to the applicable troubleshooting procedure.

NO

System performing to specification at this time.

DTC P0743 TORQUE CONVERTER CLUTCH CIRCUIT - ELECTRICAL

COMPONENT LOCATION E6FDB372

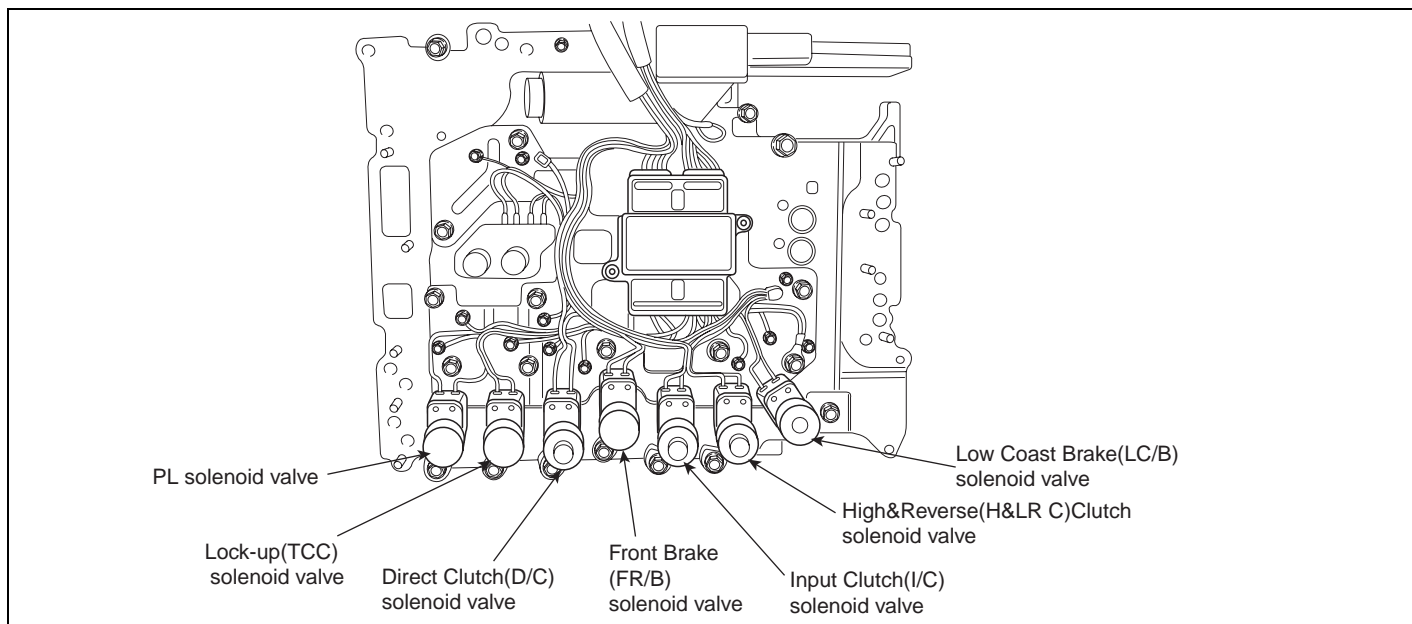

SBLAT6150L

GENERAL DESCRIPTION E1622341

Refer to DTC P0741.

DTC DESCRIPTION E02B1280

The TCM checks the Damper Clutch Control Signal by monitoring the feedback signal from the solenoid valve drive circuit. If an unexpected signal is monitored, (For example, high voltage is detected when low voltage is expected, or low voltage is detected when high voltage is expected) the TCM judges that the DCCSV circuit is malfunctioning and sets this code.

DTC DETECTING CONDITION E2F631E3

[DSL 2.5]

Item	Detecting Condition	Possible cause
DTC Strategy	<ul style="list-style-type: none"> Check voltage range 	TORQUE CON- VERTER(DAMPER) CLUTCH : TCC <ul style="list-style-type: none"> Open or short in circuit Faulty TCC SOLENOID VALVE Faulty PCM/TCM
Enable Conditions	<ul style="list-style-type: none"> CONTINUOUS 	
Threshold value	<ul style="list-style-type: none"> Ground short/open :Monitoring value[current] 0.05A, When the driver output 0.49A B+ short : Monitoring value[current] 0.4A, When the driver output 0.75A 	
Diagnostic Time	<ul style="list-style-type: none"> More than 5sec 	
Fail Safe	<ul style="list-style-type: none"> Lock-up control is prohibited(L/U off) 	

[GSL 3.3/3.8]

Item	Detecting Condition	Possible cause
DTC Strategy	• Check voltage range	TORQUE CON- VERTER(DAMPER) CLUTCH : TCC • Open or short in circuit • Faulty TCC SOLENOID VALVE • Faulty PCM/TCM
Enable Conditions	• 10V < Actuator power supply voltage < 16V	
Threshold value	• Hardware "IC" check	
Diagnostic Time	• More than 0.2sec	
Fail Safe	• Lock-up control is prohibited(L/U off)	

MONITOR SCANTOOL DATA EAAF92B2

1. Connect scantool to data link connector(DLC).
2. Engine "ON".
3. Monitor the "TCC SOL. VALVE" parameter on the scantool.
4. Select "D RANGE" and Operate the vehicle 5 gear.
5. Check "TCC SOL. VALVE" parameter value changes while driving.

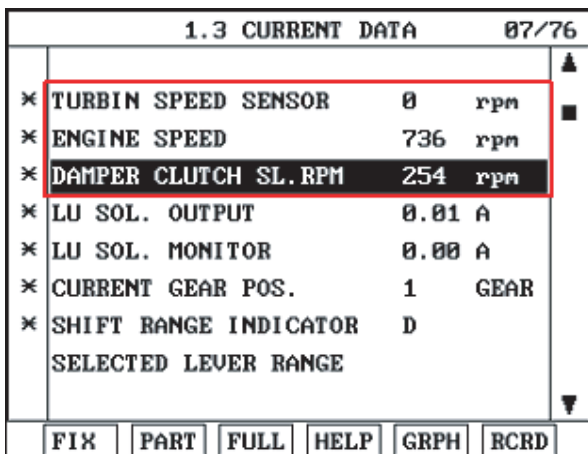

FIG.1)

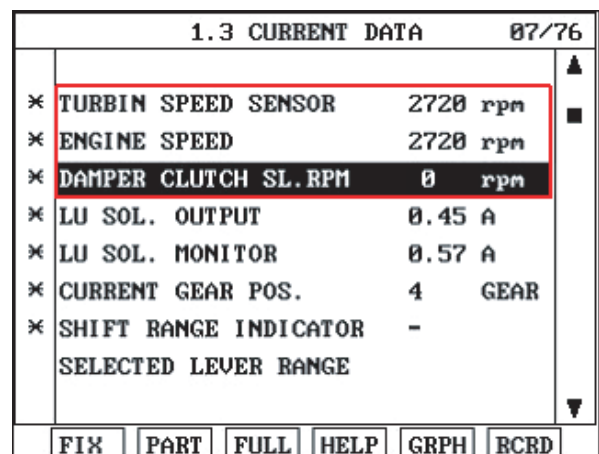

FIG.2)

FIG.1) Not engagement status of TCC

FIG.2) Engagement status of TCC

SBLAT6151L

6. Does "TCC SOLENOID DUTY " follow the reference data?

YES

Fault is intermittent caused by poor contact in the sensor's and/or TCM(PCM)'s connector or was repaired and TCM(PCM) memory was not cleared. Thoroughly check connectors for looseness, poor connection, bending, corrosion, contamination, deterioration or damage. Repair or replace as necessary and go to "Verification of vehicle repair" procedure.

NO

Go to "Terminal & connector inspection " procedure.

AT -114

AUTOMATIC TRANSAXLE (A5SR1/2)

TERMINAL & CONNECTOR INSPECTION E5928B4F

Refer to DTC P0741.

SIGNAL CIRCUIT INSPECTION EC912FC6

1. Disconnect "C06-2/C106-2" connector.
2. IGNITION "ON", ENGINE "OFF".
3. Measure voltage between terminal "9" of the C06-2/C106-2 harness connector and chassis ground.

Specification : approx. 5V

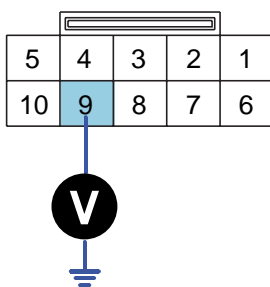

C06-2 [DSL 2.5]
C106-2 [GSL 3.3/3.8]

- 1.ATF 2
- 2.LOW COAST BRAKE SOLENOID VALVE
- 3.HIGH&LOW REVERSE CLUTCH SOLENOID VALVE
- 4.DIRECT CLUTCH SOLENOID VALVE
- 6.FRONT BRAKE SOLENOID VALVE
- 7.INPUT CLUTCH SOLENOID VALVE
- 8.PCSV(LINE PRESSURE CONTROL SOLENOID VALVE)
- 9.TCCSV

SBLAT6152L

4. Is voltage within specifications?

YES

Go to "Component inspection" procedure.

NO

Check for open or short in harness. Repair as necessary and Go to "Verification of Vehicle Repair" procedure. If signal circuit in harness is OK, Substitute with a known-good TCM and check for proper operation. If the problem is corrected, replace TCM as necessary and go to "Verification of Vehicle Repair" procedure.

COMPONENT INSPECTION E50BFCCD

Refer to DTC P0741.

VERIFICATION OF VEHICLE REPAIR EE4E905B

Refer to DTC P0741.

DTC P0748 PRESSURE CONTROL SOLENOID VALVE A - ELECTRICAL

COMPONENT LOCATION E26C6DC7

Refer to DTC P0743.

GENERAL DESCRIPTION E0B9B1BD

The line pressure solenoid valve regulates the oil pump discharge pressure to suit the driving condition in response to a signal sent from the TCM. The line pressure duty cycle valve is not consistent when the closed throttle position signal is "ON".

DTC DESCRIPTION E0E0DEB5

To confirm the line pressure duty cycle at low pressure, the accelerator (throttle) should be open until the closed throttle position signal is "OFF".

DTC DETECTING CONDITION EEFCA025

[DSL 2.5]

Item	Detecting Condition	Possible cause
DTC Strategy	<ul style="list-style-type: none">• Check voltage range	PRESSURE CONTROL SOLENOID VALVE(LINE PRESSURE : PCSV(PL. SOL)) <ul style="list-style-type: none">• Open or short in circuit• Faulty PCSV• Faulty TCM
Enable Conditions	<ul style="list-style-type: none">• CONTINUOUS	
Threshold value	<ul style="list-style-type: none">• Ground short/open : Monitoring value[current] 0.05A, When the driver output 0.49A• B+ short : Monitoring value[current] 0.4A, When the driver output 0.75A	
Diagnostic Time	<ul style="list-style-type: none">• More than 5sec	
Fail Safe	<ul style="list-style-type: none">• 5 gear is prohibited.(L/U off)• Sports mode is prohibited.	

[GSL 3.3/3.8]

Item	Detecting Condition	Possible cause
DTC Strategy	<ul style="list-style-type: none">• Check voltage range	PRESSURE CONTROL SOLENOID VALVE(LINE PRESSURE : PCSV(PL. SOL)) <ul style="list-style-type: none">• Open or short in circuit• Faulty PCSV• Faulty TCM
Enable Conditions	<ul style="list-style-type: none">• 10V < Actuator power supply voltage < 16V	
Threshold value	<ul style="list-style-type: none">• Hardware "IC" check	
Diagnostic Time	<ul style="list-style-type: none">• More than 0.2sec	
Fail Safe	<ul style="list-style-type: none">• Lock-up control is prohibited(L/U off)	

SIGNAL WAVEFORM E76B004A

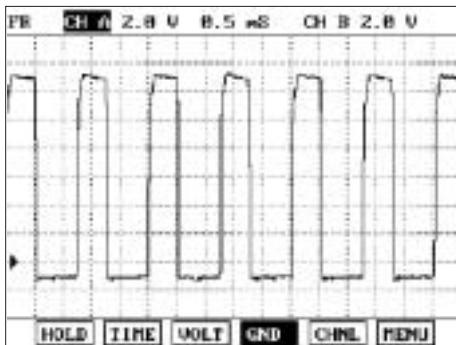

FIG.1)

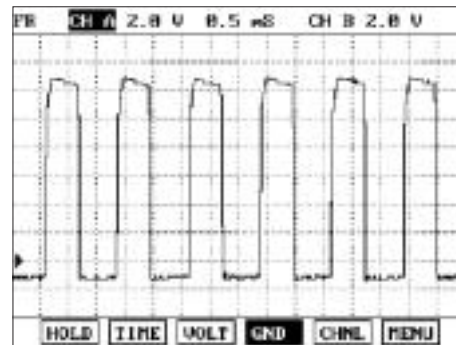

FIG.2)

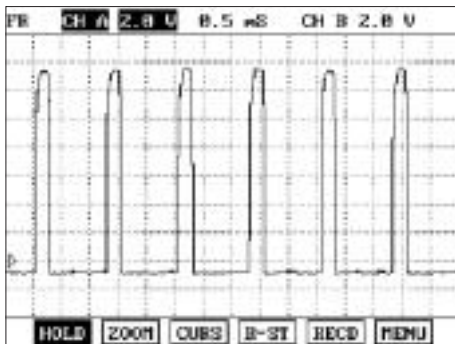

FIG.3)

FIG.1) N RANGE

FIG.2) N → D (Low pressure control)

FIG.3) STALL TEST(High pressure control)

SBLAT6155L

MONITOR SCANTOOL DATA E54BA5EB

1. Connect scantool to data link connector(DLC)
2. Engine "ON".
3. Monitor the "PCSV" parameter on the scantool.
4. Select "D RANGE" and Operate the vehicle.
5. Check "PCSV" parameter value changes while driving.

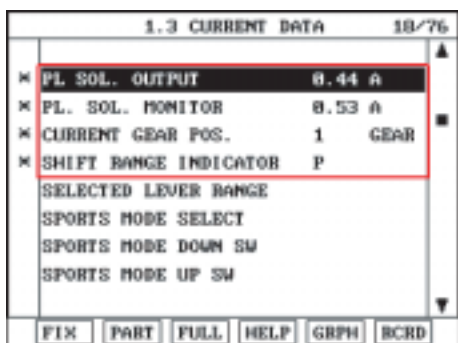

FIG.1)

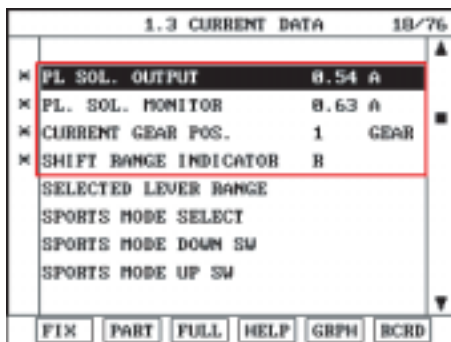

FIG.2)

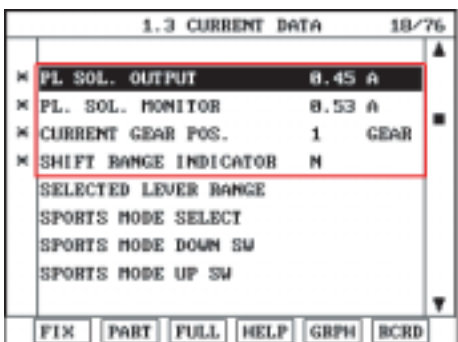

FIG.3)

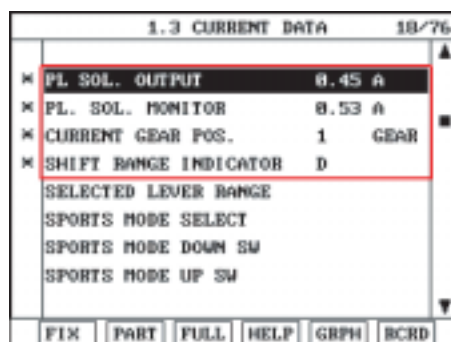

FIG.4)

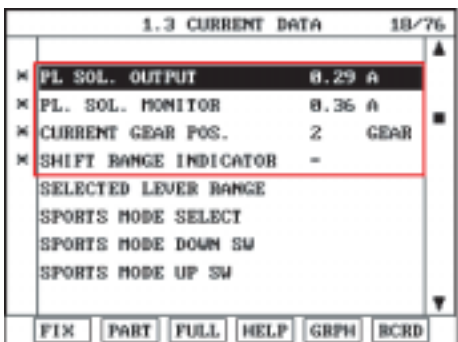

FIG.5)

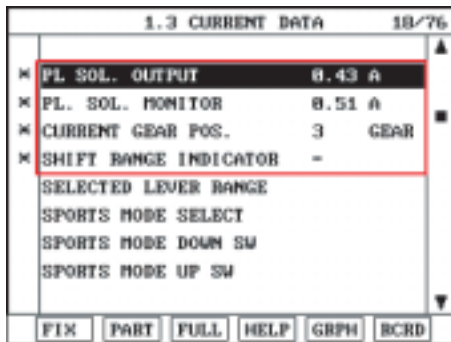

FIG.6)

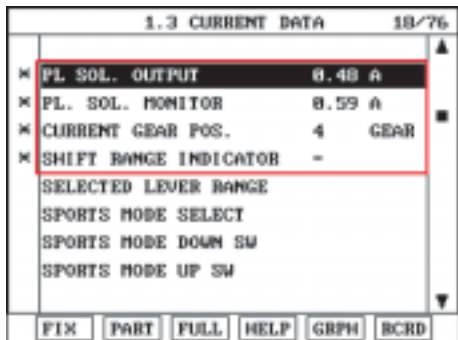

FIG.7)

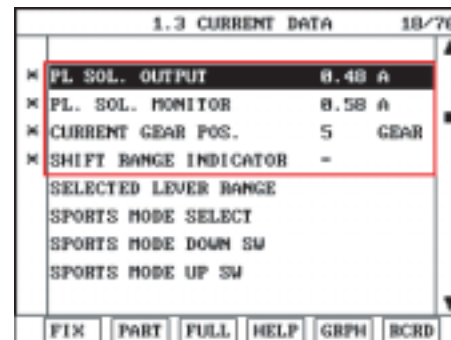

FIG.8)

FIG.1) "P" Range

FIG.2) "R" Shifting

FIG.3) "N" Range

FIG.4) "D" Range 1st gear

FIG.5) "D" Range 2nd gear

FIG.6) "D" Range 3rd gear

FIG.7) "D" Range 4th gear

FIG.8) "D" Range 5th gear

6. Does "PCSV DUTY " follow the reference data?

YES

Fault is intermittent caused by poor contact in the sensor's and/or PCM/TCM's connector or was repaired and PCM/TCM memory was not cleared. Thoroughly check connectors for looseness, poor connection, bending, corrosion, contamination, deterioration or damage. Repair or replace as necessary and go to "Verification of Vehicle Repair" procedure.

NO

Go to "Terminal & connector inspection " procedure.

TERMINAL & CONNECTOR INSPECTION E0E959CA

Refer to DTC P0741.

SIGNAL CIRCUIT INSPECTION EAA9FDC9

1. Disconnect "C06-2/C106-2" connector.
2. IGNITION "ON", ENGINE "OFF"
3. Measure voltage between terminal "8" of the C06-2/C106-2 harness connector and chassis ground.

Specification : approx. 5V

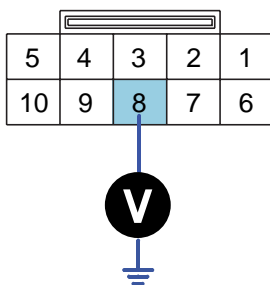

C06-2 [DSL 2.5]
C106-2 [GSL 3.3/3.8]

1. ATF 2
2. LOW COAST BRAKE SOLENOID VALVE
3. HIGH&LOW REVERSE CLUTCH SOLENOID VALVE
4. DIRECT CLUTCH SOLENOID VALVE
6. FRONT BRAKE SOLENOID VALVE
7. INPUT CLUTCH SOLENOID VALVE
8. PCSV(LINE PRESSURE CONTROL SOLENOID VALVE)
9. TCCSV

SBLAT6157L

4. Is voltage within specifications?

YES

Go to "Component inspection" procedure.

NO

Check for open or short in harness. Repair as necessary and Go to "Verification of Vehicle Repair" procedure. If signal circuit in harness is OK, Substitute with a known-good TCM and check for proper operation. If the problem is corrected, replace TCM as necessary and go to "Verification of Vehicle Repair" procedure.

AUTOMATIC TRANSAXLE SYSTEM

AT -119

COMPONENT INSPECTION ECA1DF92

1. Disconnect "C06-2/C106-2" connector.
2. Ignition "OFF".
3. Measure resistance between terminal "8" of the C06-2/C106-2 harness connector and chassis ground.

Specification : approx. 3~9

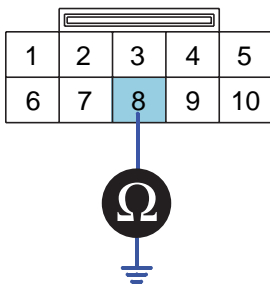

C06-2 [DSL 2.5]
C106-2 [GSL 3.3/3.8]
Component side

- 1.ATF 2
- 2.LOW COAST BRAKE SOLENOID VALVE
- 3.HIGH&LOW REVERSE CLUTCH SOLENOID VALVE
- 4.DIRECT CLUTCH SOLENOID VALVE
- 6.FRONT BRAKE SOLENOID VALVE
- 7.INPUT CLUTCH SOLENOID VALVE
- 8.PCSV(LINE PRESSURE CONTROL SOLENOID VALVE)**
- 9.TCCSV

SBLAT6158L

4. Is resistance within specifications?

YES

Thoroughly check connectors for looseness, poor connection, bending, corrosion, contamination, deterioration, or damage. Repair or replace as necessary and then go to "Verification of Vehicle Repair" procedure.

NO

5. Check for open or short in harness. Repair as necessary and Go to "Verification of Vehicle Repair" procedure. If signal circuit in harness is OK, Replace "PRESSURE CONTROL SOLENOID VALVE" as necessary and Go to "Verification of Vehicle Repair" procedure.

VERIFICATION OF VEHICLE REPAIR E92CB515

Refer to DTC P0741.

DTC P0751 SHIFT SOLENOID "A(I/C SOLENOID)" PERFORMANCE OR STUCK OFF

COMPONENT LOCATION ECF49E1B

Refer to DTC P0743.

GENERAL DESCRIPTION E3DAE4CD

The Automatic Transmission changes the gear position of the transmission utilizing a combination of Clutches and Brakes, which are controlled by solenoid valves. Input clutch solenoid valve is controlled by the TCM in response to signals sent from the inhibitor switch, vehicle speed sensor and accelerator pedal position sensor (throttle position sensor). Gears will then be shifted to the optimum position.

DTC DESCRIPTION E8FA9C0B

This is not only caused by electrical malfunction (circuits open or shorted) but also by mechanical malfunction such as control valve sticking, improper solenoid valve operation.

DTC DETECTING CONDITION E8B0C782

Item	Detecting Condition	Possible cause
DTC Strategy	<ul style="list-style-type: none">• Rationality check (stuck-off)	INPUT CLUTCH SOLENOID VALVE : I/C SOLENOID VALVE <ul style="list-style-type: none">• Open or short in circuit• Faulty I/C SOLENOID VALVE• Faulty TCM
Enable Conditions	<ul style="list-style-type: none">• Vehicle speed 6.2MPH(10km/h)• Engine speed > 305 rpm• A/T range switch is D range• A/T flued temperature -40°F	
Threshold value	<ul style="list-style-type: none">• Fluid pressure switch A "OFF" when the monitoring value 0.05A and When there's a difference between calculated and measured gear ratio.	
Diagnostic Time	<ul style="list-style-type: none">• A/T flued temperature > 14°F : More then 2secs• A/T flued temperature 14°F : More then 8secs	
Fail Safe	<ul style="list-style-type: none">• Locked in to 4th gear.	

SIGNAL WAVEFORM

E561905F

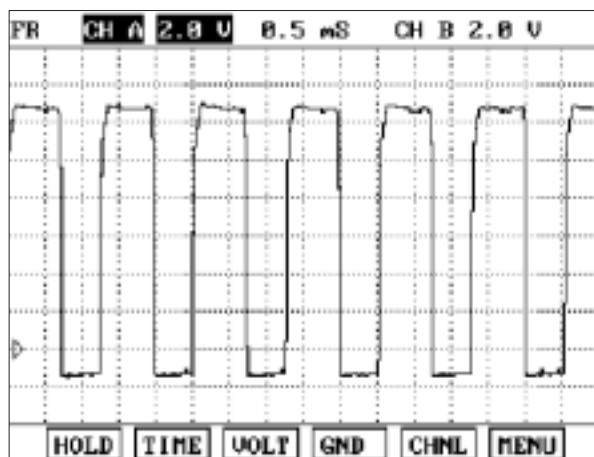

FIG.1)

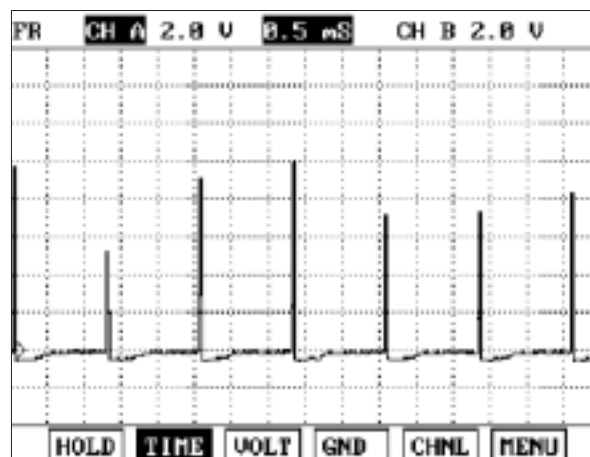

FIG.2)

FIG.1) N RANGE

FIG.2) 4 GEAR

SBLAT6160L

MONITOR SCANTOOL DATA

EE49E2D2

1. Connect scantool to data link connector(DLC)
2. Engine "ON".
3. Monitor the "I/C SOLENOID" parameter on the scantool.
4. Select "D RANGE" and Operate the vehicle.
5. Check "I/C SOLENOID" parameter value changes while driving.

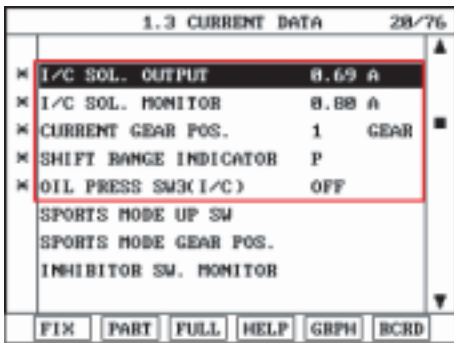

FIG.1)

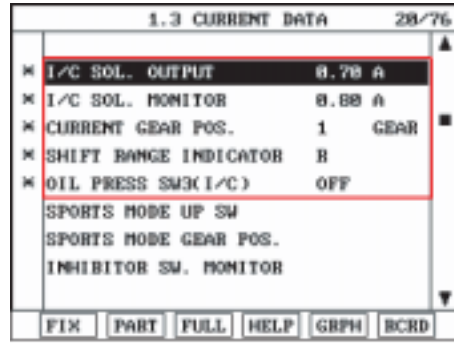

FIG.2)

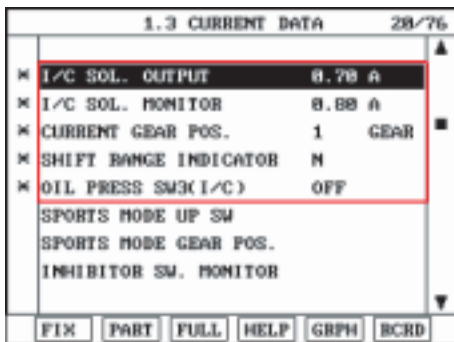

FIG.3)

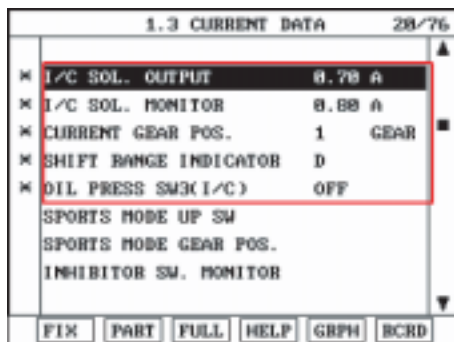

FIG.4)

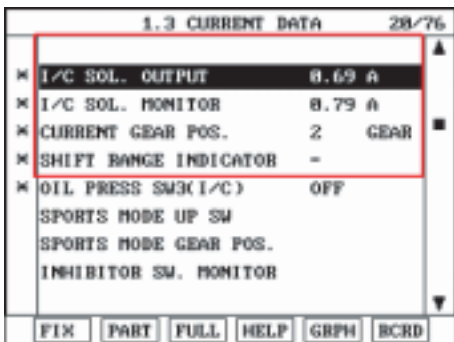

FIG.5)

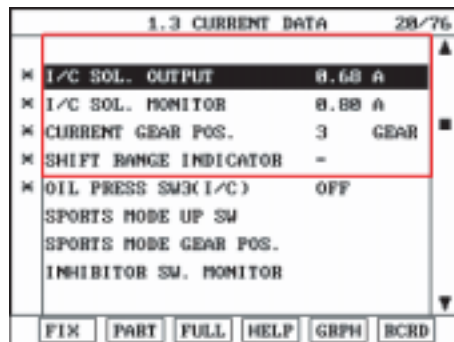

FIG.6)

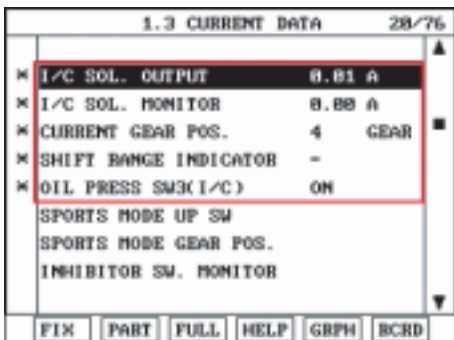

FIG.7)

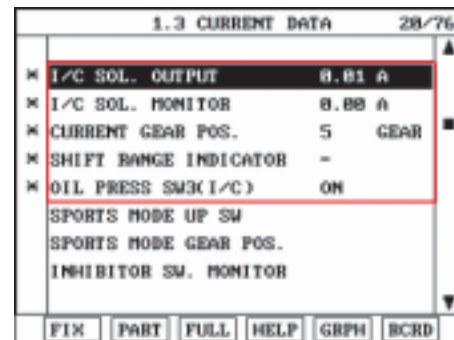

FIG.8)

FIG.1) "P" Range

FIG.2) "R" Shifting

FIG.3) "N" Range

FIG.4) "D" Range 1st gear

FIG.5) "D" Range 2nd gear

FIG.6) "D" Range 3rd gear

FIG.7) "D" Range 4th gear

FIG.8) "D" Range 5th gear

AUTOMATIC TRANSAXLE SYSTEM

AT -123

6. Does "I/C SOLENOID " follow the reference data?

YES

Fault is intermittent caused by poor contact in the sensor's and/or PCM/TCM's connector or was repaired and PCM/TCM memory was not cleared. Thoroughly check connectors for looseness, poor connection, bending, corrosion, contamination, deterioration or damage. Repair or replace as necessary and go to "Verification of Vehicle Repair" procedure.

NO

Go to "Terminal & connector inspection " procedure.

TERMINAL & CONNECTOR INSPECTION ED42F680

Refer to DTC P0741.

SIGNAL CIRCUIT INSPECTION ED9D8DEE

1. Disconnect "C06-2" connector.
2. IGNITION "ON", ENGINE "OFF"
3. Measure voltage between terminal "7" of the C06-2 harness connector and chassis ground.

Specification : Output voltage repeated between 4V and 12V

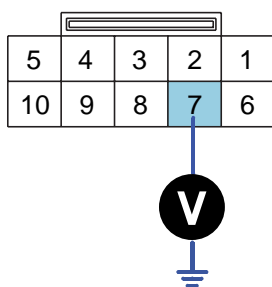

C06-2

1. ATF 2
2. LOW COAST BRAKE SOLENOID VALVE
3. HIGH&LOW REVERSE CLUTCH SOLENOID VALVE
4. DIRECT CLUTCH SOLENOID VALVE
6. FRONT BRAKE SOLENOID VALVE
7. **INPUT CLUTCH SOLENOID VALVE**
8. PCSV(LINE PRESSURE CONTROL SOLENOID VALVE)
9. TCCSV

SBLAT6162L

4. Is voltage within specifications?

YES

Go to "Component inspection" procedure.

NO

Check for open or short in harness. Repair as necessary and Go to "Verification of Vehicle Repair" procedure. If signal circuit in harness is OK, Substitute with a known-good TCM and check for proper operation. If the problem is corrected, replace TCM as necessary and go to "Verification of Vehicle Repair" procedure.

COMPONENT INSPECTION E51054EE

1. Disconnect "C06-2" connector.
2. Ignition "OFF".
3. Measure resistance between terminal "7" of the C06-2 harness connector and chassis ground.

Specification : approx. 3~9

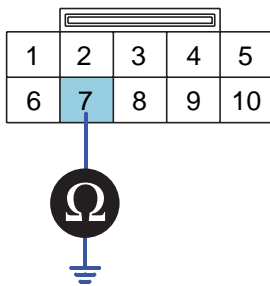

C06-2
Component side

1. ATF 2
2. LOW COAST BRAKE SOLENOID VALVE
3. HIGH&LOW REVERSE CLUTCH SOLENOID VALVE
4. DIRECT CLUTCH SOLENOID VALVE
6. FRONT BRAKE SOLENOID VALVE
- 7. INPUT CLUTCH SOLENOID VALVE**
8. PCSV(LINE PRESSURE CONTROL SOLENOID VALVE)
9. TCCSV

SBLAT6163L

4. Is resistance within specifications?

YES

Thoroughly check connectors for looseness, poor connection, bending, corrosion, contamination, deterioration, or damage. Repair or replace as necessary and then go to "Verification of Vehicle Repair" procedure.

NO

5. Check for open or short in harness. Repair as necessary and Go to "Verification of Vehicle Repair" procedure. If signal circuit in harness is OK, Replace "I/C SOLENOID VALVE" as necessary and Go to "Verification of Vehicle Repair" procedure.

VERIFICATION OF VEHICLE REPAIR EAD35AB6

Refer to DTC P0741.

DTC P0752 SHIFT SOLENOID "A(I/C SOLENOID)" PERFORMANCE OR STUCK ON

COMPONENT LOCATION EAD4FEC6

Refer to DTC P0743.

GENERAL DESCRIPTION EFAFC701

Refer to DTC P0751.

DTC DESCRIPTION E04A8BCD

Refer to DTC P0751.

DTC DETECTING CONDITION E4FFAD34

Item	Detecting Condition	Possible cause
DTC Strategy	<ul style="list-style-type: none">• Rationality check (stuck-on)	INPUT CLUTCH SOLENOID VALVE : I/C SOLENOID VALVE <ul style="list-style-type: none">• Open or short in circuit• Faulty I/C SOLENOID VALVE• Faulty TCM
Enable Conditions	<ul style="list-style-type: none">• Vehicle speed 6.2MPH(10km/h)• Engine speed > 305 rpm• A/T range switch is D range• A/T flued temperature -40°F	
Threshold value	<ul style="list-style-type: none">• Fluid pressure switch A "ON" when the monitoring value 0.75A and When there's a difference between calculated and measured gear ratio.	
Diagnostic Time	<ul style="list-style-type: none">• A/T flued temperature > 14°F : More then 2secs• A/T flued temperature 14°F : More then 8secs	
Fail Safe	<ul style="list-style-type: none">• Locked in to 4th gear.	

SIGNAL WAVEFORM E8C8C8BE

Refer to DTC P0751.

MONITOR SCANTOOL DATA E6E34514

Refer to DTC P0751.

TERMINAL & CONNECTOR INSPECTION E2A3E5FC

Refer to DTC P0741.

AT -126

AUTOMATIC TRANSAXLE (A5SR1/2)

SIGNAL CIRCUIT INSPECTION EDF1E3CE

Refer to DTC P0751.

COMPONENT INSPECTION ECBE4A49

Refer to DTC P0751.

VERIFICATION OF VEHICLE REPAIR EFF6D248

Refer to DTC P0741.

DTC P0753 SHIFT SOLENOID "A(I/C SOLENOID)" CIRCUIT - OPEN OR SHORT(GND)

COMPONENT LOCATION E9B5F58B

Refer to DTC P0743.

GENERAL DESCRIPTION E76A10E1

The Automatic Transmission changes the gear position of the transmission utilizing a combination of Clutches and Brakes, which are controlled by solenoid valves. Input clutch solenoid valve is controlled by the TCM in response to signals sent from the inhibitor switch, vehicle speed sensor and accelerator pedal position sensor (throttle position sensor). Gears will then be shifted to the optimum position.

DTC DESCRIPTION EDD1FFD6

This is not only caused by electrical malfunction (circuits open or shorted) but also by mechanical malfunction such as control valve sticking, improper solenoid valve operation.

DTC DETECTING CONDITION EBC60397

[DSL 2.5]

Item	Detecting Condition	Possible cause
DTC Strategy	<ul style="list-style-type: none">• Check voltage range	INPUT CLUTCH SOLENOID VALVE : I/C SOLENOID VALVE <ul style="list-style-type: none">• Open or short in circuit• Faulty I/C SOLENOID VALVE• Faulty TCM
Enable Conditions	<ul style="list-style-type: none">• Vehicle speed 6.2MPH(10km/h)	
Threshold value	<ul style="list-style-type: none">• Ground short/open :Monitoring value[current] 0.4A, When the driver output 0.7A• B+ short:Monitoring value[current] 0.4A, When the driver output 0.7A	
Diagnostic Time	<ul style="list-style-type: none">• more than 5sec	
Fail Safe	<ul style="list-style-type: none">• 5 gear is prohibited.(L/U off)• Sports mode is prohibited.	

[GSL 3.3/3.8]

Item	Detecting Condition	Possible cause
DTC Strategy	<ul style="list-style-type: none">• Check voltage range	INPUT CLUTCH SOLENOID VALVE : I/C SOLENOID VALVE <ul style="list-style-type: none">• Open or short in circuit• Faulty I/C SOLENOID VALVE• Faulty TCM
Enable Conditions	<ul style="list-style-type: none">• 10V < Actuator power supply voltage < 16V	
Threshold value	<ul style="list-style-type: none">• Hardware "IC" check	
Diagnostic Time	<ul style="list-style-type: none">• More than 0.2sec	
Fail Safe	<ul style="list-style-type: none">• Lock-up control is prohibited(L/U off)	

SIGNAL WAVEFORM ECFA76E2

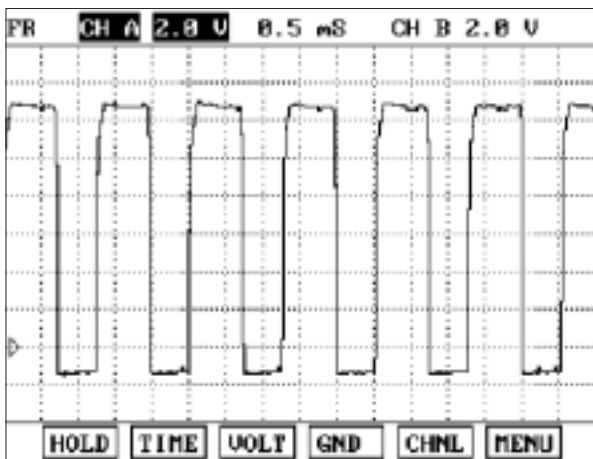

FIG.1)

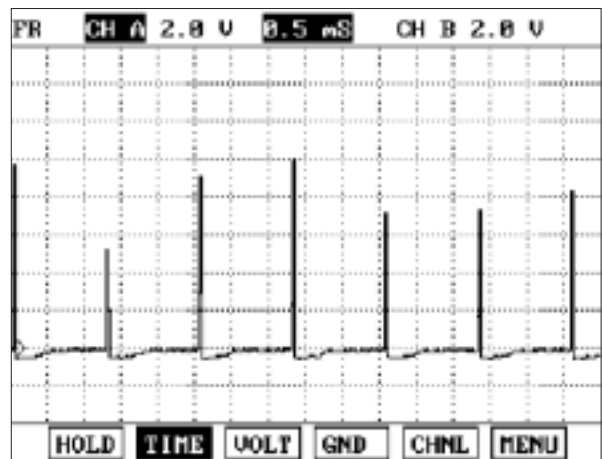

FIG.2)

FIG.1) N RANGE

FIG.2) 4 GEAR

SBLAT6160L

MONITOR SCANTOOL DATA EC6E2FB2

1. Connect scantool to data link connector(DLC)
2. Engine "ON".
3. Monitor the "I/C SOLENOID" parameter on the scantool.
4. Select "D RANGE" and Operate the vehicle.
5. Check "I/C SOLENOID" parameter value changes while driving.

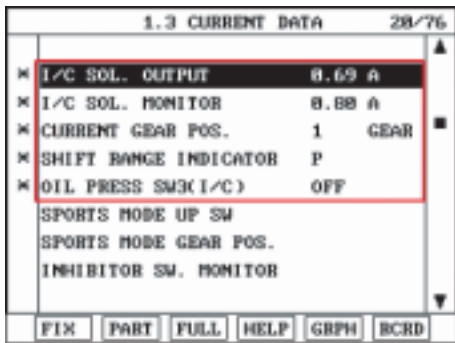

FIG.1)

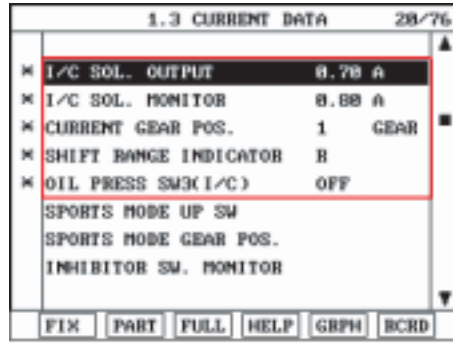

FIG.2)

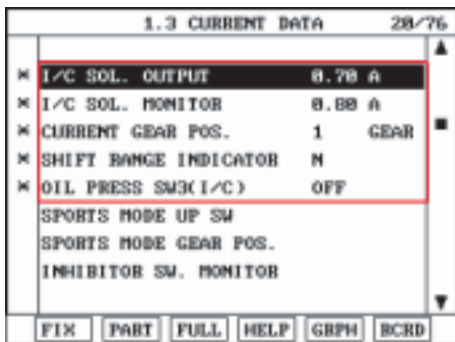

FIG.3)

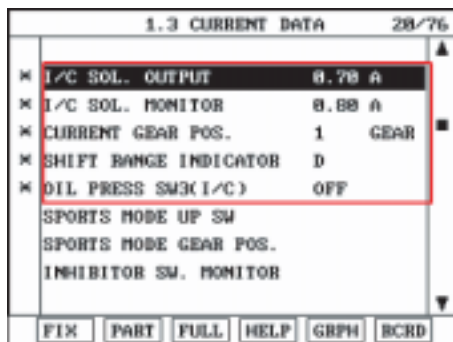

FIG.4)

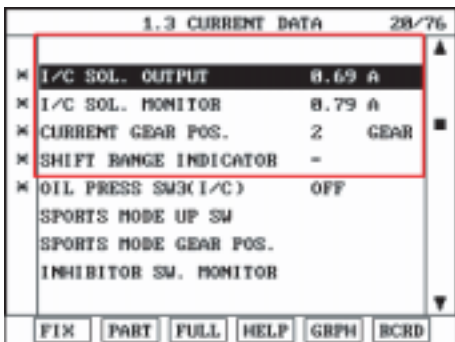

FIG.5)

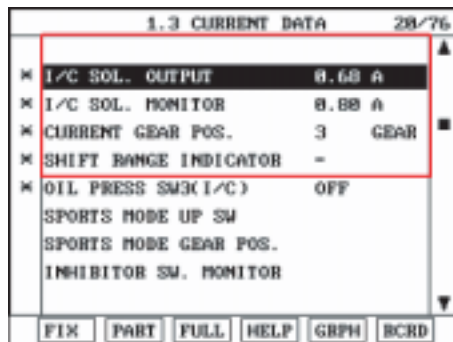

FIG.6)

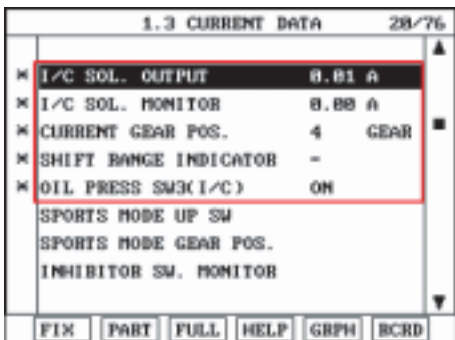

FIG.7)

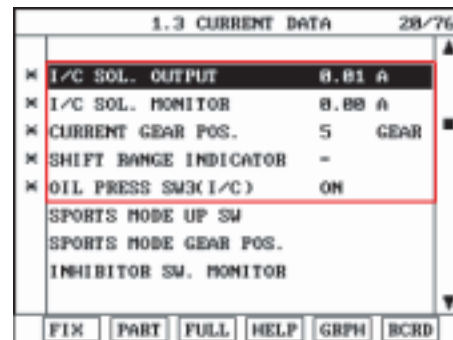

FIG.8)

FIG.1) "P" Range

FIG.2) "R" Shifting

FIG.3) "N" Range

FIG.4) "D" Range 1st gear

FIG.5) "D" Range 2nd gear

FIG.6) "D" Range 3rd gear

FIG.7) "D" Range 4th gear

FIG.8) "D" Range 5th gear

6. Does "I/C SOLENOID " follow the reference data?

YES

Fault is intermittent caused by poor contact in the sensor's and/or PCM/TCM's connector or was repaired and PCM/TCM memory was not cleared. Thoroughly check connectors for looseness, poor connection, bending, corrosion, contamination, deterioration or damage. Repair or replace as necessary and go to "Verification of Vehicle Repair" procedure.

NO

Go to "Terminal & connector inspection " procedure.

TERMINAL & CONNECTOR INSPECTION EA9EADEB

Refer to DTC P0741.

SIGNAL CIRCUIT INSPECTION EA3475FB

1. Disconnect "C06-2/C106-2" connector.
2. IGNITION "ON", ENGINE "OFF"
3. Measure voltage between terminal "7" of the C06-2/C106-2 harness connector and chassis ground.

Specification : Output voltage repeated between 4V and 12V

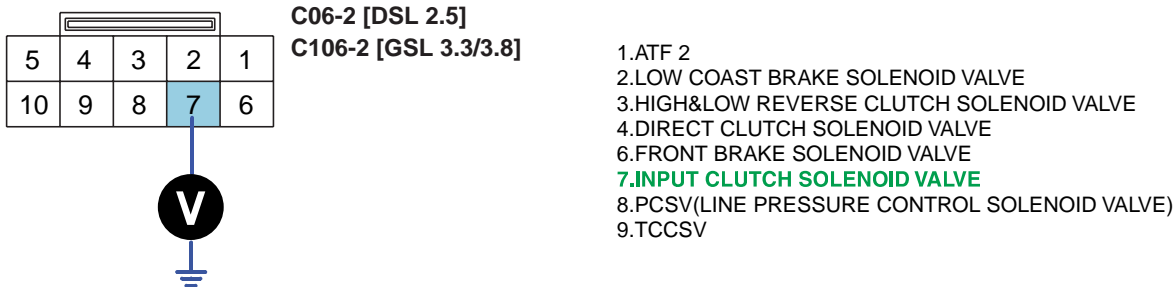

SBLAT6164L

4. Is voltage within specifications?

YES

Go to "Component inspection" procedure.

NO

Check for open or short in harness. Repair as necessary and Go to "Verification of Vehicle Repair" procedure. If signal circuit in harness is OK, Substitute with a known-good TCM and check for proper operation. If the problem is corrected, replace TCM as necessary and go to "Verification of Vehicle Repair" procedure.

AUTOMATIC TRANSAXLE SYSTEM

AT -131

COMPONENT INSPECTION E67D9ED2

1. Disconnect "C06-2/C106-2" connector.
2. Ignition "OFF".
3. Measure resistance between terminal "7" of the C06-2/C106-2 harness connector and chassis ground.

Specification : approx. 3~9

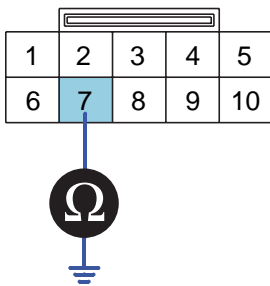

C06-2 [DSL 2.5]
C106-2 [GSL 3.3/3.8]
Component side

- 1.ATF 2
- 2.LOW COAST BRAKE SOLENOID VALVE
- 3.HIGH&LOW REVERSE CLUTCH SOLENOID VALVE
- 4.DIRECT CLUTCH SOLENOID VALVE
- 6.FRONT BRAKE SOLENOID VALVE
- 7.INPUT CLUTCH SOLENOID VALVE**
- 8.PCSV(LINE PRESSURE CONTROL SOLENOID VALVE)
- 9.TCCSV

SBLAT6169L

4. Is resistance within specifications?

YES

Thoroughly check connectors for looseness, poor connection, bending, corrosion, contamination, deterioration, or damage. Repair or replace as necessary and then go to "Verification of Vehicle Repair" procedure.

NO

5. Check for open or short in harness. Repair as necessary and Go to "Verification of Vehicle Repair" procedure. If signal circuit in harness is OK, Replace "I/C SOLENOID VALVE" as necessary and Go to "Verification of Vehicle Repair" procedure.

VERIFICATION OF VEHICLE REPAIR ECE7BF67

Refer to DTC P0741.

DTC P0756 SHIFT SOLENOID "B(FR/B SOLENOID)" PERFORMANCE OR STUCK OFF

COMPONENT LOCATION E236DAF1

Refer to DTC P0743.

GENERAL DESCRIPTION E45ABDA1

The Automatic Transmission changes the gear position of the transmission utilizing a combination of Clutches and Brakes, which are controlled by solenoid valves. Front brake solenoid valve is controlled by the TCM in response to signals sent from the inhibitor switch, vehicle speed sensor and accelerator pedal position sensor (throttle position sensor). Gear will then be shifted to the optimum position.

DTC DESCRIPTION E60D3D2C

This is not only caused by electrical malfunction (circuit open or shorted) but also by mechanical malfunction such as control valve sticking, improper solenoid valve operation.

DTC DETECTING CONDITION E18FAB08

Item	Detecting Condition	Possible cause
DTC Strategy	<ul style="list-style-type: none">• Rationality check (stuck-off)	FRONT BRAKE SOLENOID VALVE : Fr/B SOLENOID VALVE <ul style="list-style-type: none">• Open or short in circuit• Faulty Fr/B SOLENOID VALVE• Faulty TCM
Enable Conditions	<ul style="list-style-type: none">• Vehicle speed 6.2MPH(10km/h)• Engine speed > 305 rpm• A/T range switch is D range• A/T flued temperature -40°F	
Threshold value	<ul style="list-style-type: none">• Fluid pressure switch B "OFF" when the monitoring value 0.75A and When there's a difference between calculated and measured gear ratio.	
Diagnostic Time	<ul style="list-style-type: none">• A/T flued temperature > 14°F : More then 2secs• A/T flued temperature 14°F : More then 8secs	
Fail Safe	<ul style="list-style-type: none">• Locked in to 4th gear.	

SIGNAL WAVEFORM EA3C4C88

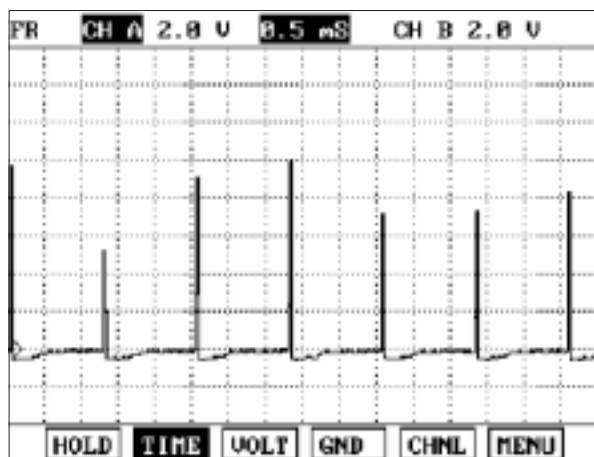

FIG.1)

FIG.1) R RANGE

FIG.2) 4 GEAR

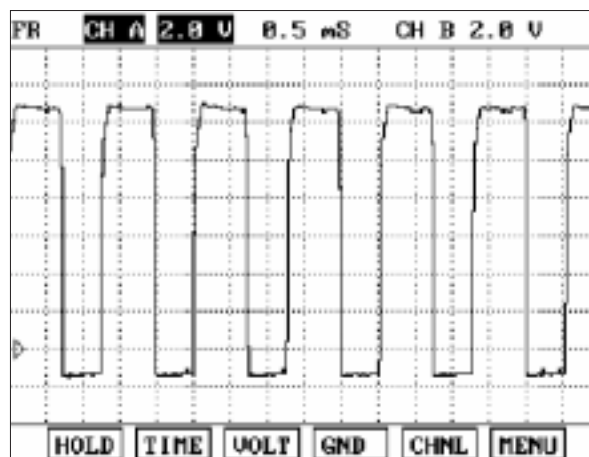

FIG.2)

SBLAT6165L

MONITOR SCANTOOL DATA EE97C5CC

1. Connect scantool to data link connector(DLC).
2. Engine "ON".
3. Monitor the "Fr/B SOLENOID" parameter on the scantool.
4. Select "R,D RANGE" and Operate the vehicle.
5. Check "Fr/B SOLENOID" parameter value changes while driving.

1.3 CURRENT DATA		22/76
* FR/B SOL. OUTPUT	0.78 A	
* FR/B SOL. MONITOR	0.88 A	
* CURRENT GEAR POS.	1 GEAR	
* SHIFT RANGE INDICATOR	P	
* OIL PRESS SW1(FR/B)	ON	
BRAKE SWITCH		
REVERSE LAMP		
STARTER RELAY MONITOR		

FIG.1)

1.3 CURRENT DATA		22/76
* FR/B SOL. OUTPUT	0.71 A	
* FR/B SOL. MONITOR	0.79 A	
* CURRENT GEAR POS.	1 GEAR	
* SHIFT RANGE INDICATOR	R	
* OIL PRESS SW1(FR/B)	ON	
BRAKE SWITCH		
REVERSE LAMP		
STARTER RELAY MONITOR		

FIG.2)

1.3 CURRENT DATA		22/76
* FR/B SOL. OUTPUT	0.71 A	
* FR/B SOL. MONITOR	0.88 A	
* CURRENT GEAR POS.	1 GEAR	
* SHIFT RANGE INDICATOR	N	
* OIL PRESS SW1(FR/B)	ON	
BRAKE SWITCH		
REVERSE LAMP		
STARTER RELAY MONITOR		

FIG.3)

1.3 CURRENT DATA		22/76
* FR/B SOL. OUTPUT	0.71 A	
* FR/B SOL. MONITOR	0.88 A	
* CURRENT GEAR POS.	1 GEAR	
* SHIFT RANGE INDICATOR	D	
* OIL PRESS SW1(FR/B)	ON	
BRAKE SWITCH		
REVERSE LAMP		
STARTER RELAY MONITOR		

FIG.4)

1.3 CURRENT DATA		22/76
* FR/B SOL. OUTPUT	0.78 A	
* FR/B SOL. MONITOR	0.88 A	
* CURRENT GEAR POS.	2 GEAR	
* SHIFT RANGE INDICATOR	-	
* OIL PRESS SW1(FR/B)	ON	
BRAKE SWITCH		
REVERSE LAMP		
STARTER RELAY MONITOR		

FIG.5)

1.3 CURRENT DATA		22/76
* FR/B SOL. OUTPUT	0.69 A	
* FR/B SOL. MONITOR	0.79 A	
* CURRENT GEAR POS.	3 GEAR	
* SHIFT RANGE INDICATOR	-	
* OIL PRESS SW1(FR/B)	ON	
BRAKE SWITCH		
REVERSE LAMP		
STARTER RELAY MONITOR		

FIG.6)

1.3 CURRENT DATA		22/76
* FR/B SOL. OUTPUT	0.81 A	
* FR/B SOL. MONITOR	0.88 A	
* CURRENT GEAR POS.	4 GEAR	
* SHIFT RANGE INDICATOR	-	
* OIL PRESS SW1(FR/B)	OFF	
BRAKE SWITCH		
REVERSE LAMP		
STARTER RELAY MONITOR		

FIG.7)

1.3 CURRENT DATA		22/76
* FR/B SOL. OUTPUT	0.68 A	
* FR/B SOL. MONITOR	0.88 A	
* CURRENT GEAR POS.	5 GEAR	
* SHIFT RANGE INDICATOR	-	
* OIL PRESS SW1(FR/B)	ON	
BRAKE SWITCH		
REVERSE LAMP		
STARTER RELAY MONITOR		

FIG.8)

FIG.1) "P" Range

FIG.2) "R" Shifting

FIG.3) "N" Range

FIG.4) "D" Range 1st gear

FIG.5) "D" Range 2nd gear

FIG.6) "D" Range 3rd gear

FIG.7) "D" Range 4th gear

FIG.8) "D" Range 5th gear

AUTOMATIC TRANSAXLE SYSTEM

AT -135

6. Does "Fr/B SOLENOID " follow the reference data?

YES

Fault is intermittent caused by poor contact in the sensor's and/or PCM/TCM's connector or was repaired and PCM/TCM memory was not cleared. Thoroughly check connectors for looseness, poor connection, bending, corrosion, contamination, deterioration or damage. Repair or replace as necessary and go to "Verification of Vehicle Repair" procedure.

NO

Go to "Terminal & connector inspection " procedure.

TERMINAL & CONNECTOR INSPECTION E8A37870

Refer to DTC P0741.

SIGNAL CIRCUIT INSPECTION E538BAF7

1. Disconnect "C06-2" connector.
2. IGNITION "ON", ENGINE "OFF"
3. Measure voltage between terminal "6" of the C06-2 harness connector and chassis ground.

Specification : approx. 5V

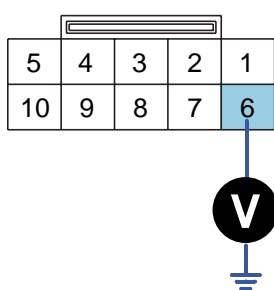

C06-2

- 1.ATF 2
- 2.LOW COAST BRAKE SOLENOID VALVE
- 3.HIGH&LOW REVERSE CLUTCH SOLENOID VALVE
- 4.DIRECT CLUTCH SOLENOID VALVE
- 6.FRONT BRAKE SOLENOID VALVE
- 7.INPUT CLUTCH SOLENOID VALVE
- 8.PCSV(LINE PRESSURE CONTROL SOLENOID VALVE)
- 9.TCCSV

SBLAT6167L

4. Is voltage within specifications?

YES

Go to "Component inspection" procedure.

NO

Check for open or short in harness. Repair as necessary and Go to "Verification of Vehicle Repair" procedure. If signal circuit in harness is OK, Substitute with a known-good TCM and check for proper operation. If the problem is corrected, replace TCM as necessary and go to "Verification of Vehicle Repair" procedure.

COMPONENT INSPECTION E7E26ED4

1. Disconnect "C06-2" connector.
2. Ignition "OFF".
3. Measure resistance between terminal "6" of the C06-2 harness connector and chassis ground.

Specification : approx. 3~9



C06-2
Component side

- 1.ATF 2
- 2.LOW COAST BRAKE SOLENOID VALVE
- 3.HIGH&LOW REVERSE CLUTCH SOLENOID VALVE
- 4.DIRECT CLUTCH SOLENOID VALVE
- 6.FRONT BRAKE SOLENOID VALVE
- 7.INPUT CLUTCH SOLENOID VALVE
- 8.PCSV(LINE PRESSURE CONTROL SOLENOID VALVE)
- 9.TCCSV

SBLAT6168L

4. Is resistance within specifications?

YES

Thoroughly check connectors for looseness, poor connection, bending, corrosion, contamination, deterioration, or damage. Repair or replace as necessary and then go to "Verification of Vehicle Repair" procedure.

NO

5. Check for open or short in harness. Repair as necessary and Go to "Verification of Vehicle Repair" procedure. If signal circuit in harness is OK, Replace "Fr/B SOLENOID VALVE" as necessary and Go to "Verification of Vehicle Repair" procedure.

VERIFICATION OF VEHICLE REPAIR E52479B8

Refer to DTC P0741.

DTC P0757 SHIFT SOLENOID "B(FR/B SOLENOID)" PERFORMANCE OR STUCK ON

COMPONENT LOCATION EE6F9305

Refer to DTC P0743.

GENERAL DESCRIPTION EF38F8BB

Refer to DTC P0756.

DTC DESCRIPTION E6CFABA9

Refer to DTC P0756.

DTC DETECTING CONDITION E3AB62E4

Item	Detecting Condition	Possible cause
DTC Strategy	<ul style="list-style-type: none">• Rationality check (stuck-off)	FRONT BRAKE SOLENOID VALVE : Fr/B SOLENOID VALVE <ul style="list-style-type: none">• Open or short in circuit• Faulty Fr/B SOLENOID VALVE• Faulty TCM
Enable Conditions	<ul style="list-style-type: none">• Vehicle speed 6.2MPH(10km/h)• Engine speed > 305 rpm• A/T range switch is D range• A/T flued temperature -40°F	
Threshold value	<ul style="list-style-type: none">• Fluid pressure switch B "ON" when the monitoring value 0.05A and When there's a difference between calculated and measured gear ratio.	
Diagnostic Time	<ul style="list-style-type: none">• A/T flued temperature > 14°F : More then 2secs• A/T flued temperature 14°F : More then 8secs	
Fail Safe	<ul style="list-style-type: none">• Locked in to 5th gear.	

SIGNAL WAVEFORM EDBEFB42

Refer to DTC P0756.

MONITOR SCANTOOL DATA EBF54BAD

Refer to DTC P0756.

TERMINAL & CONNECTOR INSPECTION EBE970DF

Refer to DTC P0741.

AT -138

AUTOMATIC TRANSAXLE (A5SR1/2)

SIGNAL CIRCUIT INSPECTION E5A2FEB9

Refer to DTC P0756.

COMPONENT INSPECTION EEA0DB01

Refer to DTC P0756.

VERIFICATION OF VEHICLE REPAIR EBB5CE4C

Refer to DTC P0741.

DTC P0758 SHIFT SOLENOID "B(FR/B SOLENOID)" CIRCUIT - OPEN OR SHORT(GND)

COMPONENT LOCATION EA1B05CC

Refer to DTC P0743.

GENERAL DESCRIPTION E13B04FA

The Automatic Transmission changes the gear position of the transmission utilizing a combination of Clutches and Brakes, which are controlled by solenoid valves. Front brake solenoid valve is controlled by the TCM in response to signals sent from the inhibitor switch, vehicle speed sensor and accelerator pedal position sensor (throttle position sensor). Gear will then be shifted to the optimum position.

DTC DESCRIPTION EC8EDFE1

This is not only caused by electrical malfunction (circuit open or shorted) but also by mechanical malfunction such as control valve sticking, improper solenoid valve operation.

DTC DETECTING CONDITION EB4FC2DE

[DSL 2.5]

Item	Detecting Condition	Possible cause
DTC Strategy	<ul style="list-style-type: none">• Check voltage range	FRONT BRAKE SOLENOID VALVE : Fr/B SOLENOID VALVE <ul style="list-style-type: none">• Open or short in circuit• Faulty Fr/B SOLENOID VALVE• Faulty TCM
Enable Conditions	<ul style="list-style-type: none">• Vehicle speed 6.2MPH(10km/h)	
Threshold value	<ul style="list-style-type: none">• Ground short/open :Monitoring value[current] 0.4A, When the driver output 0.7A• B+ short:Monitoring value[current] 0.4A, When the driver output 0.7A	
Diagnostic Time	<ul style="list-style-type: none">• more than 5sec	
Fail Safe	<ul style="list-style-type: none">• Locked into 4 or 5th gear, lock-up control is inhibited, pressure control is inhibited.	

[GSL 3.3/3.8]

Item	Detecting Condition	Possible cause
DTC Strategy	<ul style="list-style-type: none">• Check voltage range	FRONT BRAKE SOLENOID VALVE : Fr/B SOLENOID VALVE <ul style="list-style-type: none">• Open or short in circuit• Faulty Fr/B SOLENOID VALVE• Faulty TCM
Enable Conditions	<ul style="list-style-type: none">• 10V < Actuator power supply voltage < 16V	
Threshold value	<ul style="list-style-type: none">• Hardware "IC" check	
Diagnostic Time	<ul style="list-style-type: none">• More than 0.2sec	
Fail Safe	<ul style="list-style-type: none">• Lock-up control is prohibited(L/U off)	

SIGNAL WAVEFORM EDAD5C90

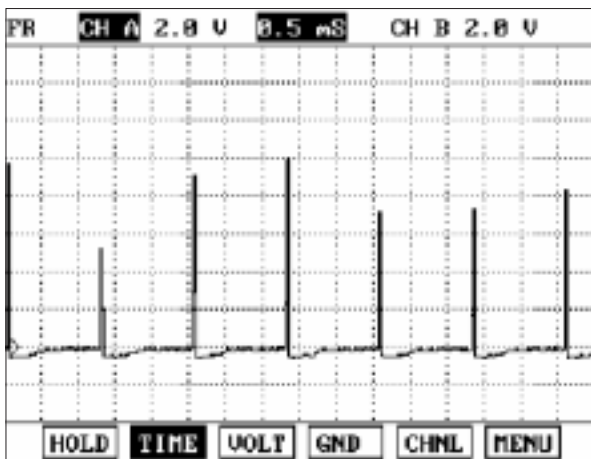

FIG.1)

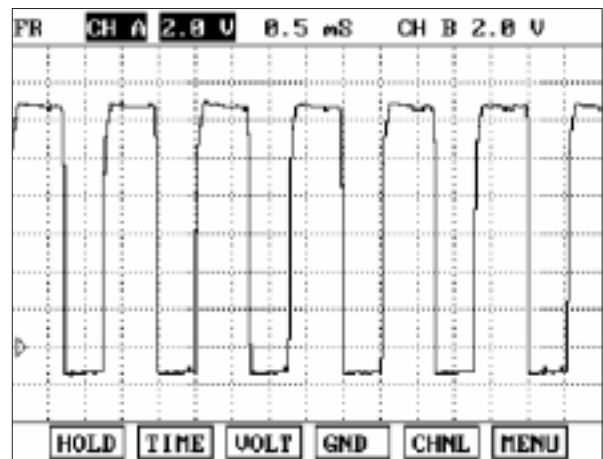

FIG.2)

FIG.1) R RANGE

FIG.2) 4 GEAR

SBLAT6165L

MONITOR SCANTOOL DATA EA4B1CCC

1. Connect scantool to data link connector(DLC)
2. Engine "ON".
3. Monitor the "Fr/B SOLENOID" parameter on the scantool.
4. Select "R,D RANGE" and Operate the vehicle.
5. Check "Fr/B SOLENOID" parameter value changes while driving.

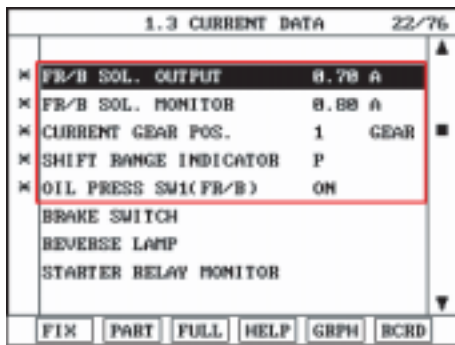

FIG.1)

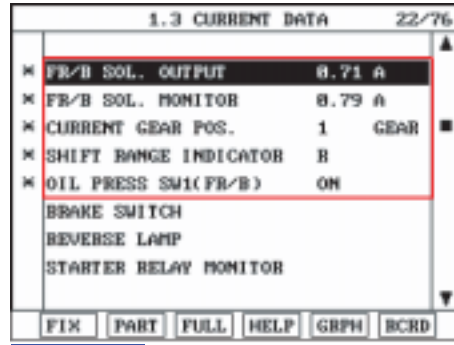

FIG.2)

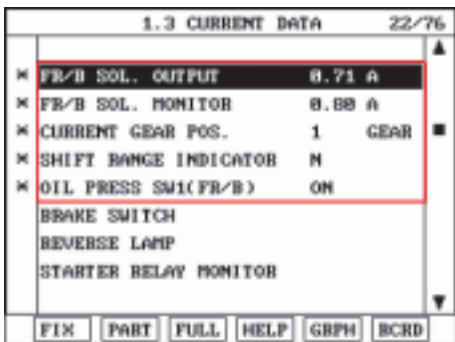

FIG.3)

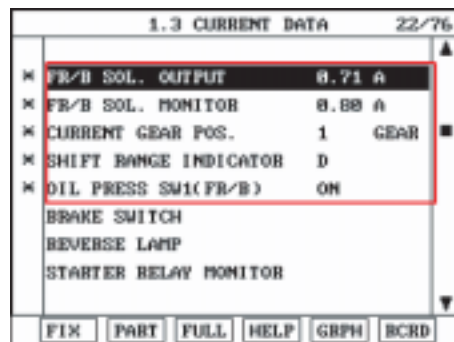

FIG.4)

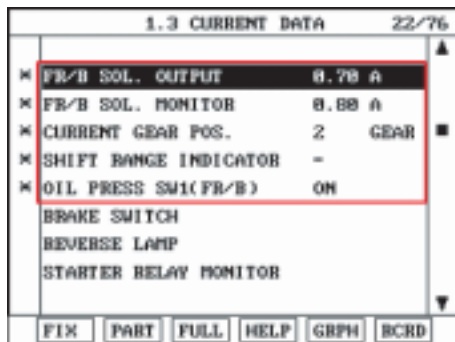

FIG.5)

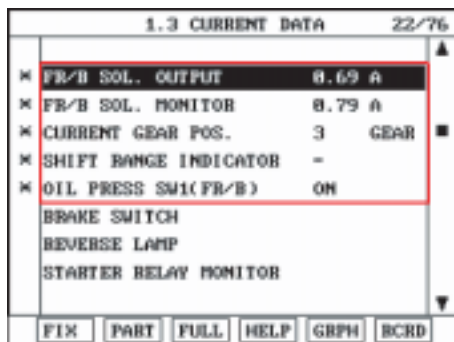

FIG.6)

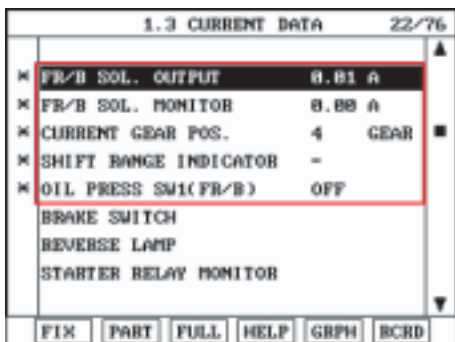

FIG.7)

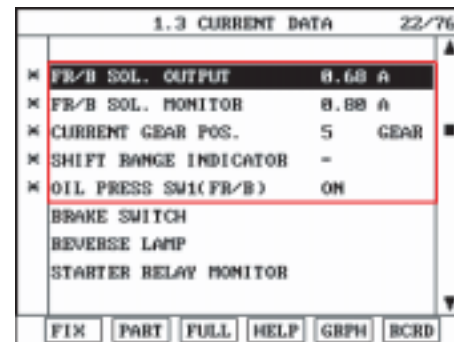

FIG.8)

FIG.1) "P" Range

FIG.2) "R" Shifting

FIG.3) "N" Range

FIG.4) "D" Range 1st gear

FIG.5) "D" Range 2nd gear

FIG.6) "D" Range 3rd gear

FIG.7) "D" Range 4th gear

FIG.8) "D" Range 5th gear

6. Does "Fr/B SOLENOID " follow the reference data?

YES

Fault is intermittent caused by poor contact in the sensor's and/or PCM/TCM's connector or was repaired and PCM/TCM memory was not cleared. Thoroughly check connectors for looseness, poor connection, bending, corrosion, contamination, deterioration or damage. Repair or replace as necessary and go to "Verification of Vehicle Repair" procedure.

NO

Go to "Terminal & connector inspection " procedure.

TERMINAL & CONNECTOR INSPECTION E12BD183

Refer to DTC P0741.

SIGNAL CIRCUIT INSPECTION EAF2B7CD

1. Disconnect "C06-2/C106-2" connector.
2. IGNITION "ON", ENGINE "OFF"
3. Measure voltage between terminal "6" of the C06-2/C106-2 harness connector and chassis ground.

Specification : approx. 5V

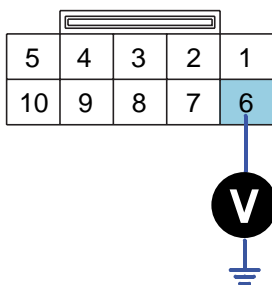

C06-2 [DSL 2.5]
C106-2 [GSL 3.3/3.8]

1. ATF 2
2. LOW COAST BRAKE SOLENOID VALVE
3. HIGH&LOW REVERSE CLUTCH SOLENOID VALVE
4. DIRECT CLUTCH SOLENOID VALVE
6. FRONT BRAKE SOLENOID VALVE
7. INPUT CLUTCH SOLENOID VALVE
8. PCSV(LINE PRESSURE CONTROL SOLENOID VALVE)
9. TCCSV

SBLAT6173L

4. Is voltage within specifications?

YES

Go to "Component inspection" procedure.

NO

Check for open or short in harness. Repair as necessary and Go to "Verification of Vehicle Repair" procedure. If signal circuit in harness is OK, Substitute with a known-good TCM and check for proper operation. If the problem is corrected, replace TCM as necessary and go to "Verification of Vehicle Repair" procedure.

AUTOMATIC TRANSAXLE SYSTEM

AT -143

COMPONENT INSPECTION

EEAB9D5D

1. Disconnect "C06-2/C106-2" connector.
2. Ignition "OFF".
3. Measure resistance between terminal "6" of the C06-2/C106-2 harness connector and chassis ground.

Specification : approx. 3~9

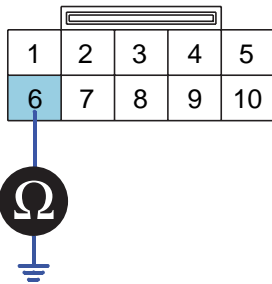

C06-2 [DSL 2.5]

C106-2 [GSL 3.3/3.8]

Component side

- 1.ATF 2
- 2.LOW COAST BRAKE SOLENOID VALVE
- 3.HIGH&LOW REVERSE CLUTCH SOLENOID VALVE
- 4.DIRECT CLUTCH SOLENOID VALVE
- 6.FRONT BRAKE SOLENOID VALVE
- 7.INPUT CLUTCH SOLENOID VALVE
- 8.PCSV(LINE PRESSURE CONTROL SOLENOID VALVE)
- 9.TCCSV

SBLAT6174L

4. Is resistance within specifications?

YES

Thoroughly check connectors for looseness, poor connection, bending, corrosion, contamination, deterioration, or damage. Repair or replace as necessary and then go to "Verification of Vehicle Repair" procedure.

NO

5. Check for open or short in harness. Repair as necessary and Go to "Verification of Vehicle Repair" procedure. If signal circuit in harness is OK, Replace "Fr/B SOLENOID VALVE" as necessary and Go to "Verification of Vehicle Repair" procedure.

VERIFICATION OF VEHICLE REPAIR

EBCCB2D4

Refer to DTC P0741.

DTC P0761 SHIFT SOLENOID "C(D/C SOLENOID)" PERFORMANCE OR STUCK OFF

COMPONENT LOCATION EEB646DB

Refer to DTC P0743.

GENERAL DESCRIPTION E0E9A4C8

The Automatic Transmission changes the gear position of the transmission utilizing a combination of Clutches and Brakes, which are controlled by solenoid valves. Direct clutch solenoid valve is controlled by the TCM in response to signals sent from the inhibitor switch, vehicle speed sensor and accelerator pedal position sensor (throttle position sensor). Gears will then be shifted to the optimum position.

DTC DESCRIPTION EFACAAB5

This is not only caused by electrical malfunction (circuits open or shorted) but also by mechanical malfunction such as control valve sticking, improper solenoid valve operation.

DTC DETECTING CONDITION E916FFD8

Item	Detecting Condition	Possible cause
DTC Strategy	<ul style="list-style-type: none">• Rationality check (stuck-off)	DIRECT CLUTCH SOLENOID VALVE : D/C SOLENOID VALVE <ul style="list-style-type: none">• Open or short in circuit• Faulty D/C SOLENOID VALVE• Faulty TCM
Enable Conditions	<ul style="list-style-type: none">• Vehicle speed 6.2MPH(10km/h)• Engine speed > 305 rpm• A/T range switch is D range• A/T flued temperature -40°F	
Threshold value	<ul style="list-style-type: none">• Fluid pressure switch C "OFF" when the monitoring value 0.05A and When there's a difference between calculated and measured gear ratio.	
Diagnostic Time	<ul style="list-style-type: none">• A/T flued temperature > 14°F : More then 2secs• A/T flued temperature 14°F : More then 8secs	
Fail Safe	<ul style="list-style-type: none">• Locked in to 4th gear.	

SIGNAL WAVEFORM E3F7D7DB

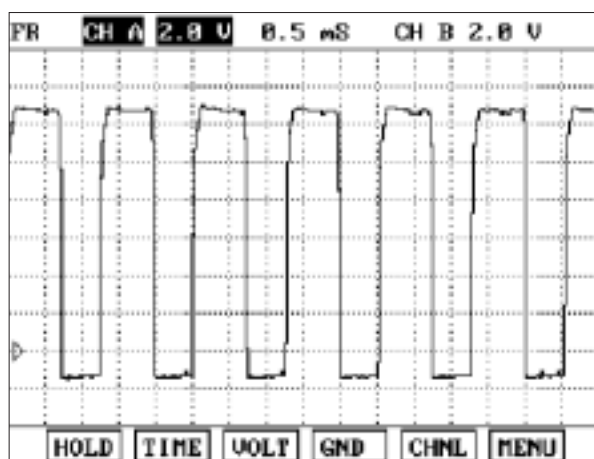

FIG.1)

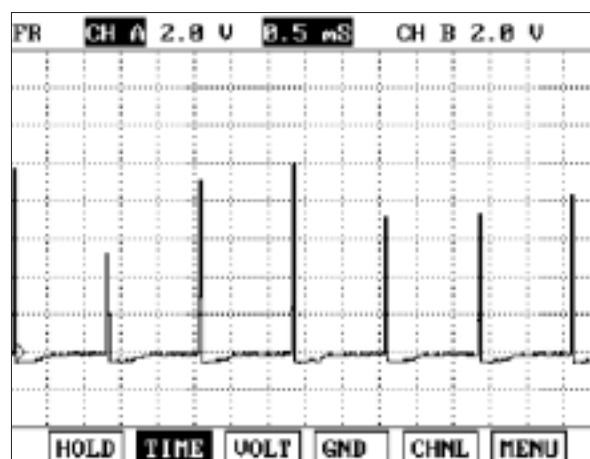

FIG.2)

FIG.1) N RANGE

FIG.2) 2 GEAR

SBLAT6185L

MONITOR SCANTOOL DATA E1AB7D5A

1. Connect scantool to data link connector(DLC).
2. Engine "ON".
3. Monitor the "D/C SOLENOID" parameter on the scantool.
4. Select "D RANGE" and Operate the vehicle.
5. Check "D/C SOLENOID" parameter value changes while driving.

1.3 CURRENT DATA		24/76
* D/C SOL. OUTPUT	0.72 A	
* D/C SOL. MONITOR	0.79 A	
* CURRENT GEAR POS.	1 GEAR	
* SHIFT RANGE INDICATOR	P	
* OIL PRESS SW5(D/C)	OFF	
OIL PRESS SW3(I/C)		
OIL PRESS SW2(LC/B)		
OIL PRESS SW1(FR/B)		

FIG.1)

1.3 CURRENT DATA		24/76
* D/C SOL. OUTPUT	0.72 A	
* D/C SOL. MONITOR	0.88 A	
* CURRENT GEAR POS.	1 GEAR	
* SHIFT RANGE INDICATOR	R	
* OIL PRESS SW5(D/C)	OFF	
OIL PRESS SW3(I/C)		
OIL PRESS SW2(LC/B)		
OIL PRESS SW1(FR/B)		

FIG.2)

1.3 CURRENT DATA		24/76
* D/C SOL. OUTPUT	0.72 A	
* D/C SOL. MONITOR	0.79 A	
* CURRENT GEAR POS.	1 GEAR	
* SHIFT RANGE INDICATOR	N	
* OIL PRESS SW5(D/C)	OFF	
OIL PRESS SW3(I/C)		
OIL PRESS SW2(LC/B)		
OIL PRESS SW1(FR/B)		

FIG.3)

1.3 CURRENT DATA		24/76
* D/C SOL. OUTPUT	0.72 A	
* D/C SOL. MONITOR	0.88 A	
* CURRENT GEAR POS.	1 GEAR	
* SHIFT RANGE INDICATOR	D	
* OIL PRESS SW5(D/C)	OFF	
OIL PRESS SW3(I/C)		
OIL PRESS SW2(LC/B)		
OIL PRESS SW1(FR/B)		

FIG.4)

1.3 CURRENT DATA		24/76
* D/C SOL. OUTPUT	0.82 A	
* D/C SOL. MONITOR	0.88 A	
* CURRENT GEAR POS.	2 GEAR	
* SHIFT RANGE INDICATOR	-	
* OIL PRESS SW5(D/C)	ON	
OIL PRESS SW3(I/C)		
OIL PRESS SW2(LC/B)		
OIL PRESS SW1(FR/B)		

FIG.5)

1.3 CURRENT DATA		24/76
* D/C SOL. OUTPUT	0.82 A	
* D/C SOL. MONITOR	0.88 A	
* CURRENT GEAR POS.	3 GEAR	
* SHIFT RANGE INDICATOR	-	
* OIL PRESS SW5(D/C)	ON	
OIL PRESS SW3(I/C)		
OIL PRESS SW2(LC/B)		
OIL PRESS SW1(FR/B)		

FIG.6)

1.3 CURRENT DATA		24/76
* D/C SOL. OUTPUT	0.82 A	
* D/C SOL. MONITOR	0.88 A	
* CURRENT GEAR POS.	4 GEAR	
* SHIFT RANGE INDICATOR	-	
* OIL PRESS SW5(D/C)	ON	
OIL PRESS SW3(I/C)		
OIL PRESS SW2(LC/B)		
OIL PRESS SW1(FR/B)		

FIG.7)

1.3 CURRENT DATA		24/76
* D/C SOL. OUTPUT	0.69 A	
* D/C SOL. MONITOR	0.88 A	
* CURRENT GEAR POS.	5 GEAR	
* SHIFT RANGE INDICATOR	-	
* OIL PRESS SW5(D/C)	OFF	
OIL PRESS SW3(I/C)		
OIL PRESS SW2(LC/B)		
OIL PRESS SW1(FR/B)		

FIG.8)

FIG.1) "P" Range

FIG.2) "R" Shifting

FIG.3) "N" Range

FIG.4) "D" Range 1st gear

FIG.5) "D" Range 2nd gear

FIG.6) "D" Range 3rd gear

FIG.7) "D" Range 4th gear

FIG.8) "D" Range 5th gear

AUTOMATIC TRANSAXLE SYSTEM

AT -147

6. Does "D/C SOLENOID" follow the reference data?

YES

Fault is intermittent caused by poor contact in the sensor's and/or PCM/TCM's connector or was repaired and PCM/TCM memory was not cleared. Thoroughly check connectors for looseness, poor connection, bending, corrosion, contamination, deterioration or damage. Repair or replace as necessary and go to "Verification of Vehicle Repair" procedure.

NO

Go to "Terminal & connector inspection " procedure.

TERMINAL & CONNECTOR INSPECTION E612BA07

Refer to DTC P0741.

SIGNAL CIRCUIT INSPECTION EFFD29A3

1. Disconnect "C06-2" connector.
2. IGNITION "ON", ENGINE "OFF"
3. Measure voltage between terminal "4" of the C06-2 harness connector and chassis ground.

Specification : approx. 5V

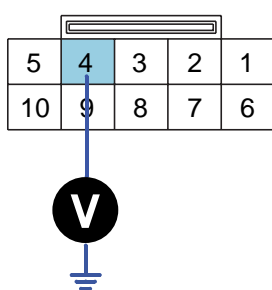

1. ATF 2
2. LOW COAST BRAKE SOLENOID VALVE
3. HIGH&LOW REVERSE CLUTCH SOLENOID VALVE
4. **DIRECT CLUTCH SOLENOID VALVE**
6. FRONT BRAKE SOLENOID VALVE
7. INPUT CLUTCH SOLENOID VALVE
8. PCSV(LINE PRESSURE CONTROL SOLENOID VALVE)
9. TCCSV

SBLAT6171L

4. Is voltage within specifications?

YES

Go to "Component inspection" procedure.

NO

Check for open or short in harness. Repair as necessary and Go to "Verification of Vehicle Repair" procedure. If signal circuit in harness is OK, Substitute with a known-good TCM and check for proper operation. If the problem is corrected, replace TCM as necessary and go to "Verification of Vehicle Repair" procedure.

COMPONENT INSPECTION E12370D8

1. Disconnect "C06-2" connector.
2. Ignition "OFF".
3. Measure resistance between terminal "4" of the C06-2 harness connector and chassis ground.

Specification : approx. 3~9

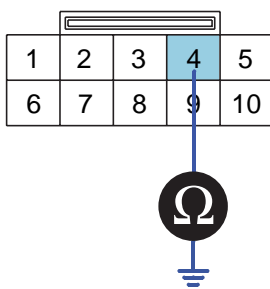

C06-2
Component side

1. ATF 2
2. LOW COAST BRAKE SOLENOID VALVE
3. HIGH&LOW REVERSE CLUTCH SOLENOID VALVE
4. **DIRECT CLUTCH SOLENOID VALVE**
6. FRONT BRAKE SOLENOID VALVE
7. INPUT CLUTCH SOLENOID VALVE
8. PCSV(LINE PRESSURE CONTROL SOLENOID VALVE)
9. TCCSV

SBLAT6172L

4. Is resistance within specifications?

YES

Thoroughly check connectors for looseness, poor connection, bending, corrosion, contamination, deterioration, or damage. Repair or replace as necessary and then go to "Verification of Vehicle Repair" procedure.

NO

5. Check for open or short in harness. Repair as necessary and Go to "Verification of Vehicle Repair" procedure. If signal circuit in harness is OK, Replace "D/C SOLENOID VALVE" as necessary and Go to "Verification of Vehicle Repair" procedure.

VERIFICATION OF VEHICLE REPAIR E6A74B9B

Refer to DTC P0741.

AUTOMATIC TRANSAXLE SYSTEM

AT -149

DTC P0762 SHIFT SOLENOID "C(D/C SOLENOID)" PERFORMANCE OR STUCK ON

COMPONENT LOCATION E1ACD282

Refer to DTC P0743.

GENERAL DESCRIPTION E13DDCC1

Refer to DTC P0761.

DTC DESCRIPTION E1A29609

Refer to DTC P0761.

DTC DETECTING CONDITION EFF2D7F2

Item	Detecting Condition	Possible cause
DTC Strategy	<ul style="list-style-type: none">• Rationality check (stuck-on)	DIRECT CLUTCH SOLENOID VALVE : D/C SOLENOID VALVE <ul style="list-style-type: none">• Open or short in circuit• Faulty D/C SOLENOID VALVE• Faulty TCM
Enable Conditions	<ul style="list-style-type: none">• Vehicle speed 6.2MPH(10km/h)• Engine speed > 305 rpm• A/T range switch is D range• A/T flued temperature -40°F	
Threshold value	<ul style="list-style-type: none">• Fluid pressure switch C "ON" when the monitoring value 0.75A and When there's a difference between calculated and measured gear ratio.	
Diagnostic Time	<ul style="list-style-type: none">• A/T flued temperature > 14°F : More then 2secs• A/T flued temperature 14°F : More then 8secs	
Fail Safe	<ul style="list-style-type: none">• Locked in to 4th gear.	

SIGNAL WAVEFORM EFFAFECD

Refer to DTC P0761.

MONITOR SCANTOOL DATA E10A10E4

Refer to DTC P0761.

TERMINAL & CONNECTOR INSPECTION EDC2E451

Refer to DTC P0741.

AT -150

AUTOMATIC TRANSAXLE (A5SR1/2)

SIGNAL CIRCUIT INSPECTION E61B3C99

Refer to DTC P0761.

COMPONENT INSPECTION E02750E3

Refer to DTC P0761.

VERIFICATION OF VEHICLE REPAIR E0D09D95

Refer to DTC P0741.

DTC P0763 SHIFT SOLENOID "C(D/C SOLENOID)" CIRCUIT - OPEN OR SHORT(GND)

COMPONENT LOCATION EC19042A

Refer to DTC P0743.

GENERAL DESCRIPTION E051B6EB

The Automatic Transmission changes the gear position of the transmission utilizing a combination of Clutches and Brakes, which are controlled by solenoid valves. Direct clutch solenoid valve is controlled by the TCM in response to signals sent from the inhibitor switch, vehicle speed sensor and accelerator pedal position sensor (throttle position sensor). Gears will then be shifted to the optimum position.

DTC DESCRIPTION E68C803A

This is not only caused by electrical malfunction (circuits open or shorted) but also by mechanical malfunction such as control valve sticking, improper solenoid valve operation.

DTC DETECTING CONDITION E8CBFF6E

[DSL 2.5]

Item	Detecting Condition	Possible cause
DTC Strategy	<ul style="list-style-type: none">• Check voltage range	DIRECT CLUTCH SOLENOID VALVE : D/C SOLENOID VALVE <ul style="list-style-type: none">• Open or short in circuit• Faulty D/C SOLENOID VALVE• Faulty TCM
Enable Conditions	<ul style="list-style-type: none">• Vehicle speed 6.2MPH(10km/h)	
Threshold value	<ul style="list-style-type: none">• Ground short/open :Monitoring value[current] 0.4A, When the driver output 0.7A• B+ short:Monitoring value[current] 0.4A, When the driver output 0.7A	
Diagnostic Time	<ul style="list-style-type: none">• More than 5sec	
Fail Safe	<ul style="list-style-type: none">• Locked into 4th gear, lock-up control is inhibited, pressure control is inhibited.	

[GSL 3.3/3.8]

Item	Detecting Condition	Possible cause
DTC Strategy	<ul style="list-style-type: none">• Check voltage range	DIRECT CLUTCH SOLENOID VALVE : D/C SOLENOID VALVE <ul style="list-style-type: none">• Open or short in circuit• Faulty D/C SOLENOID VALVE• Faulty TCM
Enable Conditions	<ul style="list-style-type: none">• 10V < Actuator power supply voltage < 16V	
Threshold value	<ul style="list-style-type: none">• Hardware "IC" check	
Diagnostic Time	<ul style="list-style-type: none">• More than 0.2sec	
Fail Safe	<ul style="list-style-type: none">• Lock-up control is prohibited(L/U off)	

SIGNAL WAVEFORM E1393CED

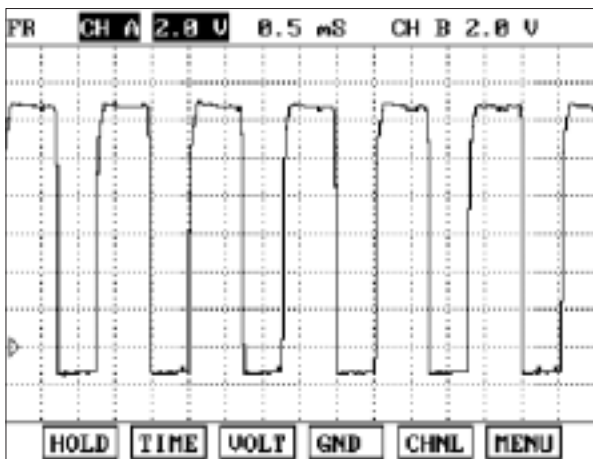

FIG.1)

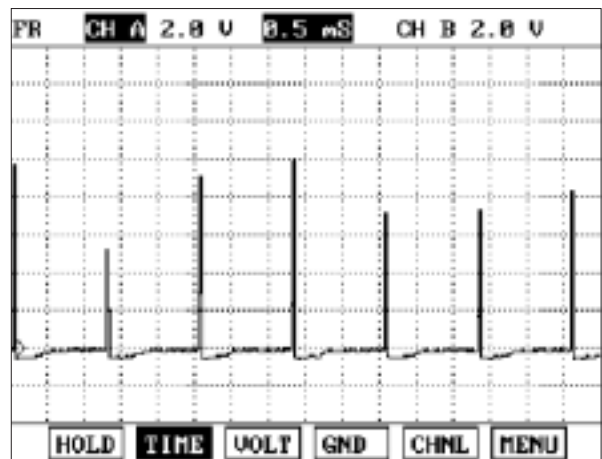

FIG.2)

FIG.1) N RANGE

FIG.2) 2 GEAR

SBLAT6185L

MONITOR SCANTOOL DATA EC07C31E

1. Connect scantool to data link connector(DLC).
2. Engine "ON".
3. Monitor the "D/C SOLENOID" parameter on the scantool.
4. Select "D RANGE" and Operate the vehicle.
5. Check "D/C SOLENOID" parameter value changes while driving.

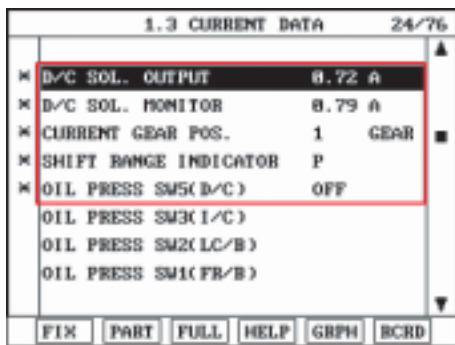

FIG.1)

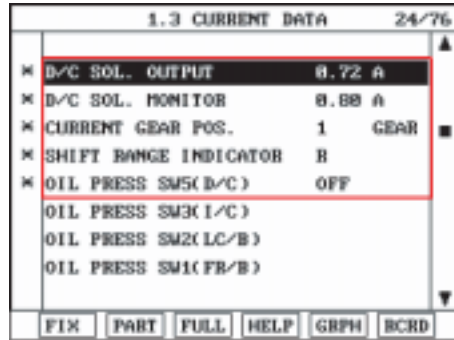

FIG.2)

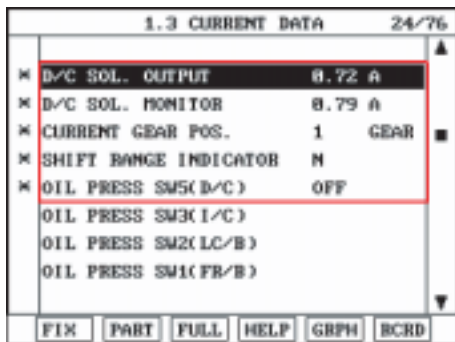

FIG.3)

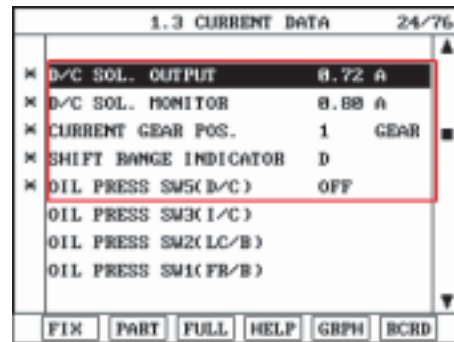

FIG.4)

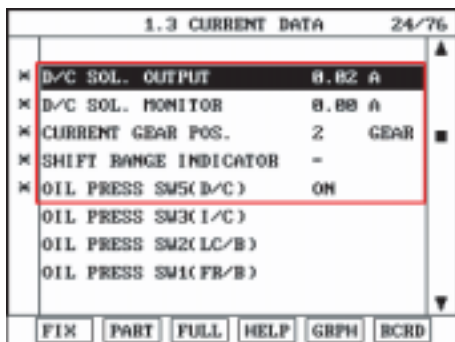

FIG.5)

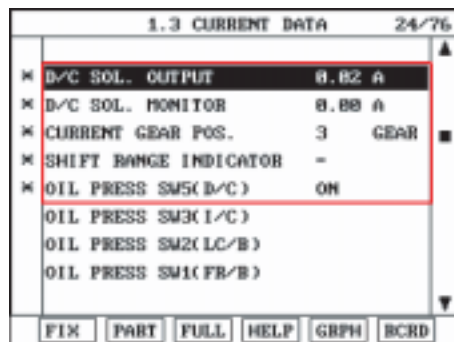

FIG.6)

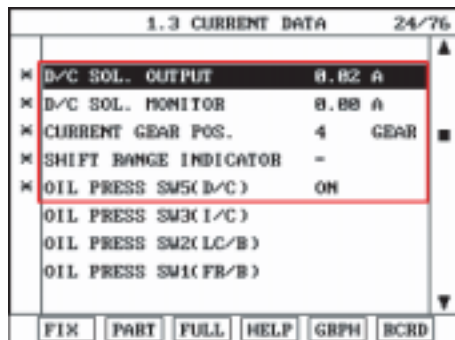

FIG.7)

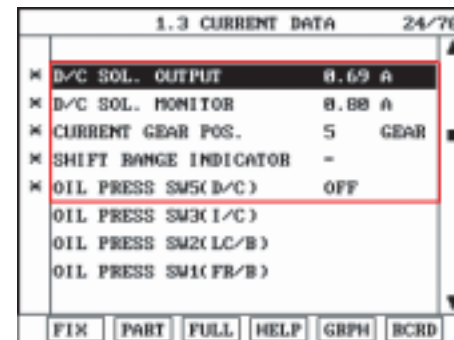

FIG.8)

FIG.1) "P" Range

FIG.2) "R" Shifting

FIG.3) "N" Range

FIG.4) "D" Range 1st gear

FIG.5) "D" Range 2nd gear

FIG.6) "D" Range 3rd gear

FIG.7) "D" Range 4th gear

FIG.8) "D" Range 5th gear

6. Does "D/C SOLENOID" follow the reference data?

YES

Fault is intermittent caused by poor contact in the sensor's and/or PCM/TCM's connector or was repaired and PCM/TCM memory was not cleared. Thoroughly check connectors for looseness, poor connection, bending, corrosion, contamination, deterioration or damage. Repair or replace as necessary and go to "Verification of Vehicle Repair" procedure.

NO

Go to "Terminal & connector inspection " procedure.

TERMINAL & CONNECTOR INSPECTION EAFB1ABA

Refer to DTC P0741.

SIGNAL CIRCUIT INSPECTION EB462AC2

1. Disconnect "C06-2/C106-2" connector.
2. IGNITION "ON", ENGINE "OFF"
3. Measure voltage between terminal "4" of the C06-2/C106-2 harness connector and chassis ground.

Specification : approx. 5V

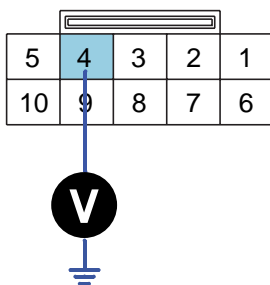

C06-2 [DSL 2.5]
C106-2 [GSL 3.3/3.8]

1. ATF 2
2. LOW COAST BRAKE SOLENOID VALVE
3. HIGH&LOW REVERSE CLUTCH SOLENOID VALVE
4. **DIRECT CLUTCH SOLENOID VALVE**
6. FRONT BRAKE SOLENOID VALVE
7. INPUT CLUTCH SOLENOID VALVE
8. PCSV(LINE PRESSURE CONTROL SOLENOID VALVE)
9. TCCSV

SBLAT6104L

4. Is voltage within specifications?

YES

Go to "Component inspection" procedure.

NO

Check for open or short in harness. Repair as necessary and Go to "Verification of Vehicle Repair" procedure. If signal circuit in harness is OK, Substitute with a known-good TCM and check for proper operation. If the problem is corrected, replace TCM as necessary and go to "Verification of Vehicle Repair" procedure.

AUTOMATIC TRANSAXLE SYSTEM

AT -155

COMPONENT INSPECTION E45A563F

1. Disconnect "C06-2/C106-2" connector.
2. Ignition "OFF".
3. Measure resistance between terminal "4" of the C06-2/C106-2 harness connector and chassis ground.

Specification : approx. 3~9

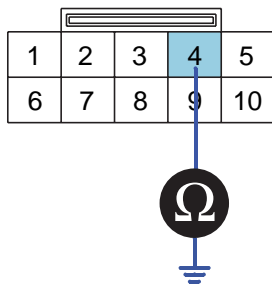

C06-2 [DSL 2.5]
C106-2 [GSL 3.3/3.8]
Component side

- 1.ATF 2
- 2.LOW COAST BRAKE SOLENOID VALVE
- 3.HIGH&LOW REVERSE CLUTCH SOLENOID VALVE
- 4.DIRECT CLUTCH SOLENOID VALVE**
- 6.FRONT BRAKE SOLENOID VALVE
- 7.INPUT CLUTCH SOLENOID VALVE
- 8.PCSV(LINE PRESSURE CONTROL SOLENOID VALVE)
- 9.TCCSV

SBLAT6105L

4. Is resistance within specifications?

YES

Thoroughly check connectors for looseness, poor connection, bending, corrosion, contamination, deterioration, or damage. Repair or replace as necessary and then go to "Verification of Vehicle Repair" procedure.

NO

5. Check for open or short in harness. Repair as necessary and Go to "Verification of Vehicle Repair" procedure. If signal circuit in harness is OK, Replace "D/C SOLENOID VALVE" as necessary and Go to "Verification of Vehicle Repair" procedure.

VERIFICATION OF VEHICLE REPAIR E6E5BE9E

Refer to DTC P0741.

DTC P0766 SHIFT SOLENOID "D(H & LR/C SOLENOID)" PERFORMANCE OR STUCK OFF

COMPONENT LOCATION EBBD9FAA

Refer to DTC P0743.

GENERAL DESCRIPTION E4377846

The Automatic Transmission changes the gear position of the transmission utilizing a combination of Clutches and Brakes, which are controlled by solenoid valves. High & low reverse clutch solenoid valve is controlled by the TCM in response to signals sent from the inhibitor switch, vehicle speed sensor and accelerator pedal position sensor (throttle position sensor). Gears will then be shifted to the optimum position.

DTC DESCRIPTION E8CA49D4

This is not only caused by electrical malfunction (circuits open or shorted) but also by mechanical malfunction such as control valve sticking, improper solenoid valve operation.

DTC DETECTING CONDITION ECF8B8EA

Item	Detecting Condition	Possible cause
DTC Strategy	<ul style="list-style-type: none">Rationality check (stuck-off)	HIGH & LOW REVERSE CLUTCH SOLENOID VALVE : H & LR/C SOLENOID <ul style="list-style-type: none">Open or short in circuitFaulty H & LR/C SOLENOID VALVEFaulty TCM
Enable Conditions	<ul style="list-style-type: none">Vehicle speed 6.2MPH(10km/h)Engine speed > 305 rpmA/T range switch is D rangeA/T flued temperature -40°F	
Threshold value	<ul style="list-style-type: none">Fluid pressure switch D "OFF" when the monitoring value 0.05A and When there's a difference between calculated and measured gear ratio.	
Diagnostic Time	<ul style="list-style-type: none">A/T flued temperature > 14°F : More then 2secsA/T flued temperature 14°F : More then 8secs	
Fail Safe	<ul style="list-style-type: none">Locked in to 4th gear.	

SIGNAL WAVEFORM EC96F3F0

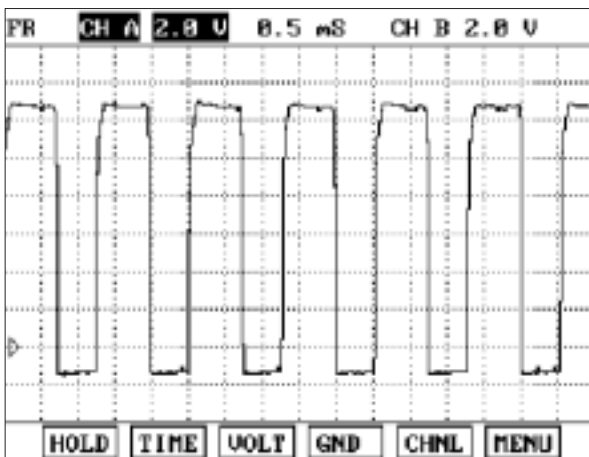

FIG.1)

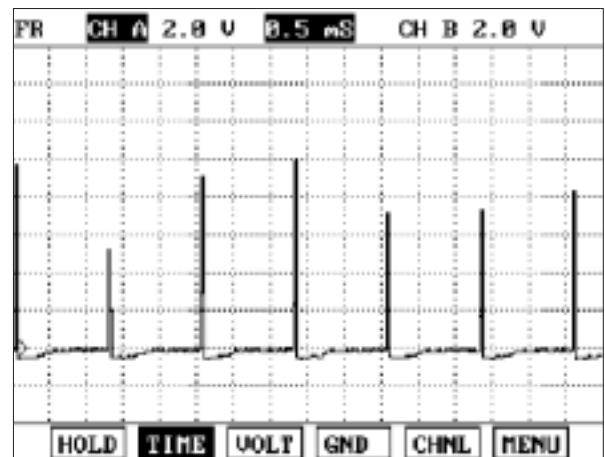

FIG.2)

FIG.1) 2 RANGE

FIG.2) 3 GEAR

SBLAT6186L

MONITOR SCANTOOL DATA EA86D7DF

1. Connect scantool to data link connector(DLC).
2. Engine "ON".
3. Monitor the "H & LR/C SOLENOID" parameter on the scantool.
4. Select "D RANGE" and Operate the vehicle.
5. Check "H & LR/C SOLENOID" parameter value changes while driving.

1.3 CURRENT DATA		26/76
× H/L B/C SOL. OUTPUT	0.01 A	
× H/L B/C SOL. MONITOR	0.00 A	
× CURRENT GEAR POS.	1 GEAR	
× SHIFT RANGE INDICATOR	P	
× OIL PRESS SW6(H/L B/C)	ON	
OIL PRESS SW5(D/C)		
OIL PRESS SW3(I/C)		
OIL PRESS SW2(LC/B)		

FIG.1)

1.3 CURRENT DATA		26/76
× H/L B/C SOL. OUTPUT	0.01 A	
× H/L B/C SOL. MONITOR	0.00 A	
× CURRENT GEAR POS.	1 GEAR	
× SHIFT RANGE INDICATOR	R	
× OIL PRESS SW6(H/L B/C)	ON	
OIL PRESS SW5(D/C)		
OIL PRESS SW3(I/C)		
OIL PRESS SW2(LC/B)		

FIG.2)

1.3 CURRENT DATA		26/76
× H/L B/C SOL. OUTPUT	0.01 A	
× H/L B/C SOL. MONITOR	0.00 A	
× CURRENT GEAR POS.	1 GEAR	
× SHIFT RANGE INDICATOR	N	
× OIL PRESS SW6(H/L B/C)	ON	
OIL PRESS SW5(D/C)		
OIL PRESS SW3(I/C)		
OIL PRESS SW2(LC/B)		

FIG.3)

1.3 CURRENT DATA		26/76
× H/L B/C SOL. OUTPUT	0.66 A	
× H/L B/C SOL. MONITOR	0.00 A	
× CURRENT GEAR POS.	1 GEAR	
× SHIFT RANGE INDICATOR	D	
× OIL PRESS SW6(H/L B/C)	OFF	
OIL PRESS SW5(D/C)		
OIL PRESS SW3(I/C)		
OIL PRESS SW2(LC/B)		

FIG.4)

1.3 CURRENT DATA		26/76
× H/L B/C SOL. OUTPUT	0.66 A	
× H/L B/C SOL. MONITOR	0.00 A	
× CURRENT GEAR POS.	2 GEAR	
× SHIFT RANGE INDICATOR	-	
× OIL PRESS SW6(H/L B/C)	OFF	
OIL PRESS SW5(D/C)		
OIL PRESS SW3(I/C)		
OIL PRESS SW2(LC/B)		

FIG.5)

1.3 CURRENT DATA		26/76
× H/L B/C SOL. OUTPUT	0.01 A	
× H/L B/C SOL. MONITOR	0.00 A	
× CURRENT GEAR POS.	3 GEAR	
× SHIFT RANGE INDICATOR	-	
× OIL PRESS SW6(H/L B/C)	ON	
OIL PRESS SW5(D/C)		
OIL PRESS SW3(I/C)		
OIL PRESS SW2(LC/B)		

FIG.6)

1.3 CURRENT DATA		26/76
× H/L B/C SOL. OUTPUT	0.01 A	
× H/L B/C SOL. MONITOR	0.00 A	
× CURRENT GEAR POS.	4 GEAR	
× SHIFT RANGE INDICATOR	-	
× OIL PRESS SW6(H/L B/C)	ON	
OIL PRESS SW5(D/C)		
OIL PRESS SW3(I/C)		
OIL PRESS SW2(LC/B)		

FIG.7)

1.3 CURRENT DATA		26/76
× H/L B/C SOL. OUTPUT	0.01 A	
× H/L B/C SOL. MONITOR	0.00 A	
× CURRENT GEAR POS.	5 GEAR	
× SHIFT RANGE INDICATOR	-	
× OIL PRESS SW6(H/L B/C)	ON	
OIL PRESS SW5(D/C)		
OIL PRESS SW3(I/C)		
OIL PRESS SW2(LC/B)		

FIG.8)

FIG.1) "P" Range

FIG.2) "R" Shifting

FIG.3) "N" Range

FIG.4) "D" Range 1st gear

FIG.5) "D" Range 2nd gear

FIG.6) "D" Range 3rd gear

FIG.7) "D" Range 4th gear

FIG.8) "D" Range 5th gear

6. Does "H & LR/C SOLENOID" follow the reference data?

YES

Fault is intermittent caused by poor contact in the sensor's and/or PCM/TCM's connector or was repaired and PCM/TCM memory was not cleared. Thoroughly check connectors for looseness, poor connection, bending, corrosion, contamination, deterioration or damage. Repair or replace as necessary and go to "Verification of Vehicle Repair" procedure.

NO

Go to "Terminal & connector inspection " procedure.

TERMINAL & CONNECTOR INSPECTION EFD661E

Refer to DTC P0741.

SIGNAL CIRCUIT INSPECTION E34F0D09

1. Disconnect "C06-2" connector.
2. IGNITION "ON", ENGINE "OFF"
3. Measure voltage between terminal "3" of the C06-2 harness connector and chassis ground.

Specification : Output voltage repeated between 4V and 12V

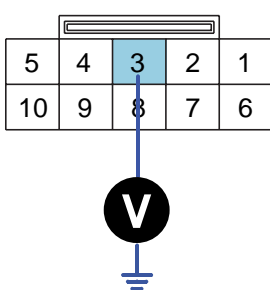

C06-2

1. ATF 2
2. LOW COAST BRAKE SOLENOID VALVE
3. **HIGH&LOW REVERSE CLUTCH SOLENOID VALVE**
4. DIRECT CLUTCH SOLENOID VALVE
6. FRONT BRAKE SOLENOID VALVE
7. INPUT CLUTCH SOLENOID VALVE
8. PCSV(LINE PRESSURE CONTROL SOLENOID VALVE)
9. TCCSV

SBLAT6176L

4. Is voltage within specifications?

YES

Go to "Component inspection" procedure.

NO

Check for open or short in harness. Repair as necessary and Go to "Verification of Vehicle Repair" procedure. If signal circuit in harness is OK, Substitute with a known-good TCM and check for proper operation. If the problem is corrected, replace TCM as necessary and go to "Verification of Vehicle Repair" procedure.

COMPONENT INSPECTION EBA7ADF9

1. Disconnect "C06-2" connector.
2. Ignition "OFF".
3. Measure resistance between terminal "3" of the C06-2 harness connector and chassis ground.

Specification : approx. 3~9

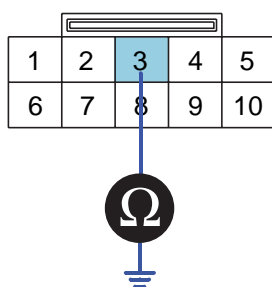

C06-2
Component side

- 1.ATF 2
- 2.LOW COAST BRAKE SOLENOID VALVE
- 3.HIGH&LOW REVERSE CLUTCH SOLENOID VALVE**
- 4.DIRECT CLUTCH SOLENOID VALVE
- 6.FRONT BRAKE SOLENOID VALVE
- 7.INPUT CLUTCH SOLENOID VALVE
- 8.PCSV(LINE PRESSURE CONTROL SOLENOID VALVE)
- 9.TCCSV

SBLAT6177L

4. Is resistance within specifications?

YES

Thoroughly check connectors for looseness, poor connection, bending, corrosion, contamination, deterioration, or damage. Repair or replace as necessary and then go to "Verification of Vehicle Repair" procedure.

NO

5. Check for open or short in harness. Repair as necessary and Go to "Verification of Vehicle Repair" procedure. If signal circuit in harness is OK, Replace "H & LR/C SOLENOID VALVE" as necessary and Go to "Verification of Vehicle Repair" procedure.

VERIFICATION OF VEHICLE REPAIR E20DFB96

Refer to DTC P0741.

DTC P0767 SHIFT SOLENOID "D(H & LR/C SOLENOID)" PERFORMANCE OR STUCK ON

COMPONENT LOCATION E68A2A4B

Refer to DTC P0743.

GENERAL DESCRIPTION E67AAEE4

Refer to DTC P0766.

DTC DESCRIPTION E7AD00EF

Refer to DTC P0766.

DTC DETECTING CONDITION EEF92CC3

Item	Detecting Condition	Possible cause
DTC Strategy	<ul style="list-style-type: none">• Rationality check (stuck-on)	HIGH & LOW REVERSE CLUTCH SOLENOID VALVE : H & LR/C SOLENOID <ul style="list-style-type: none">• Open or short in circuit• Faulty H & LR/C SOLENOID VALVE• Faulty TCM
Enable Conditions	<ul style="list-style-type: none">• Vehicle speed 6.2MPH(10km/h)• Engine speed > 305 rpm• A/T range switch is D range• A/T flued temperature -40°F	
Threshold value	<ul style="list-style-type: none">• Fluid pressure switch D "ON" when the monitoring value 0.75A and When there's a difference between calculated and measured gear ratio.	
Diagnostic Time	<ul style="list-style-type: none">• A/T flued temperature > 14°F : More then 2secs• A/T flued temperature 14°F : More then 8secs	
Fail Safe	<ul style="list-style-type: none">• Locked in to 4th gear.	

SIGNAL WAVEFORM EE4DD7CD

Refer to DTC P0766.

MONITOR SCANTOOL DATA E2DFD2F0

Refer to DTC P0766.

TERMINAL & CONNECTOR INSPECTION EC2775FD

Refer to DTC P0741.

AT -162

AUTOMATIC TRANSAXLE (A5SR1/2)

SIGNAL CIRCUIT INSPECTION EA814DBF

Refer to DTC P0766.

COMPONENT INSPECTION E089DD4A

Refer to DTC P0766.

VERIFICATION OF VEHICLE REPAIR EC0B50D0

Refer to DTC P0741.

DTC P0768 SHIFT SOLENOID "D(H & LR/C SOLENOID)" CIRCUIT - OPEN OR SHORT(GND)

COMPONENT LOCATION E8C37266

Refer to DTC P0743.

GENERAL DESCRIPTION E82A6F74

The Automatic Transmission changes the gear position of the transmission utilizing a combination of Clutches and Brakes, which are controlled by solenoid valves. High & low reverse clutch solenoid valve is controlled by the TCM in response to signals sent from the inhibitor switch, vehicle speed sensor and accelerator pedal position sensor (throttle position sensor). Gears will then be shifted to the optimum position.

DTC DESCRIPTION EE5B829A

This is not only caused by electrical malfunction (circuits open or shorted) but also by mechanical malfunction such as control valve sticking, improper solenoid valve operation.

DTC DETECTING CONDITION E7DD2DEC

[DSL 2.5]

Item	Detecting Condition	Possible cause
DTC Strategy	<ul style="list-style-type: none">• Check voltage range	HIGH & LOW REVERSE CLUTCH SOLENOID VALVE: H & LR/C SOLENOID VALVE <ul style="list-style-type: none">• Open or short in circuit• Faulty H & LR/C SOLENOID VALVE• Faulty TCM
Enable Conditions	<ul style="list-style-type: none">• Vehicle speed 6.2MPH(10km/h)	
Threshold value	<ul style="list-style-type: none">• Ground short/open :Monitoring value[current] 0.4A, When the driver output 0.7A• B+ short:Monitoring value[current] 0.4A, When the driver output 0.7A	
Diagnostic Time	<ul style="list-style-type: none">• More than 5sec	
Fail Safe	<ul style="list-style-type: none">• Locked into 4th gear, lock-up control is inhibited, pressure control is inhibited.	

[GSL 3.3/3.8]

Item	Detecting Condition	Possible cause
DTC Strategy	<ul style="list-style-type: none">• Check voltage range	HIGH & LOW REVERSE CLUTCH SOLENOID VALVE: H & LR/C SOLENOID VALVE <ul style="list-style-type: none">• Open or short in circuit• Faulty H & LR/C SOLENOID VALVE• Faulty TCM
Enable Conditions	<ul style="list-style-type: none">• 10V < Actuator power supply voltage < 16V	
Threshold value	<ul style="list-style-type: none">• Hardware "IC" check	
Diagnostic Time	<ul style="list-style-type: none">• More than 0.2sec	
Fail Safe	<ul style="list-style-type: none">• Lock-up control is prohibited(L/U off)	

SIGNAL WAVEFORM EBFFA8DB

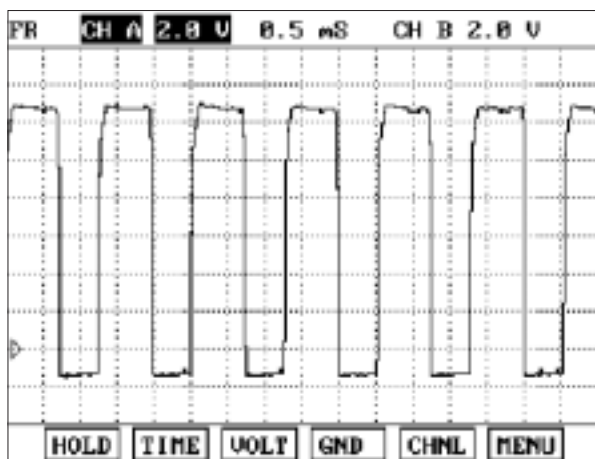

FIG.1)

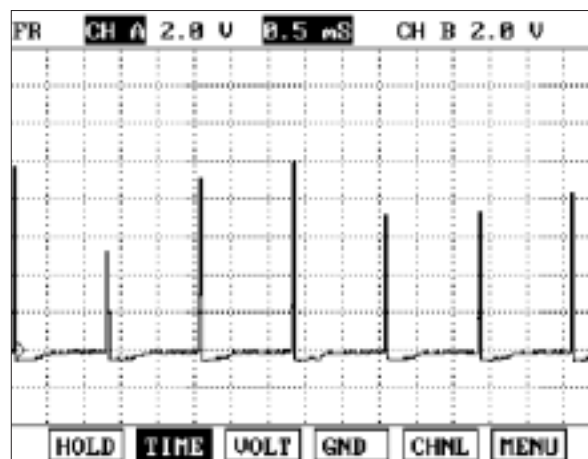

FIG.2)

FIG.1) 2 RANGE

FIG.2) 3 GEAR

SBLAT6186L

MONITOR SCANTOOL DATA EAA48A37

1. Connect scantool to data link connector(DLC).
2. Engine "ON".
3. Monitor the "H & LR/C SOLENOID" parameter on the scantool.
4. Select "D RANGE" and Operate the vehicle.
5. Check "H & LR/C SOLENOID" parameter value changes while driving.

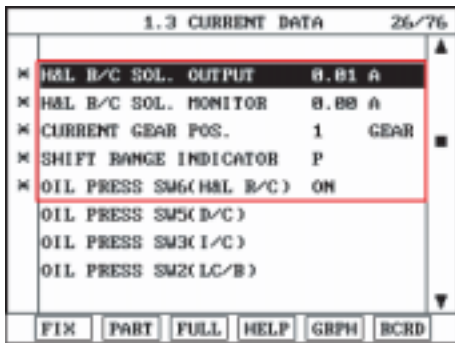

FIG.1)

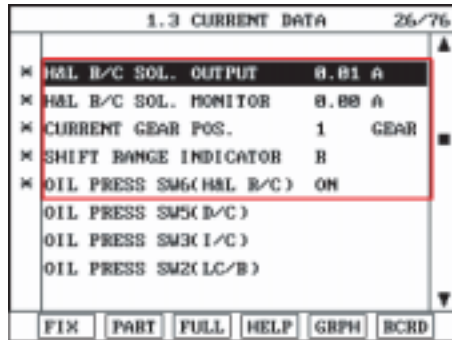

FIG.2)

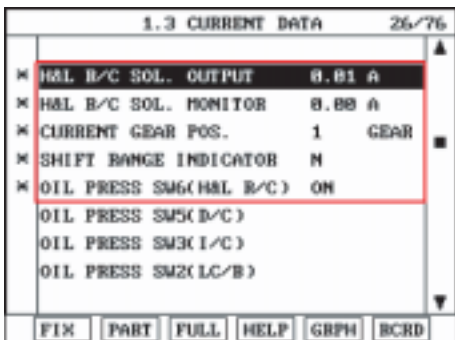

FIG.3)

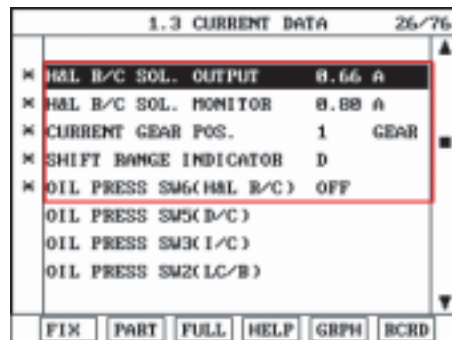

FIG.4)

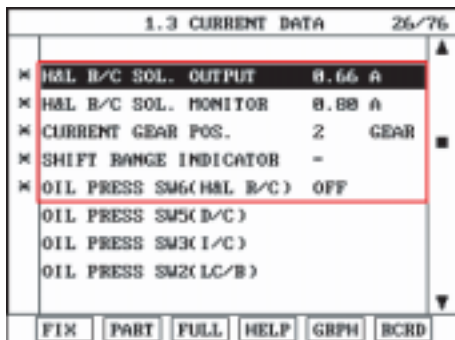

FIG.5)

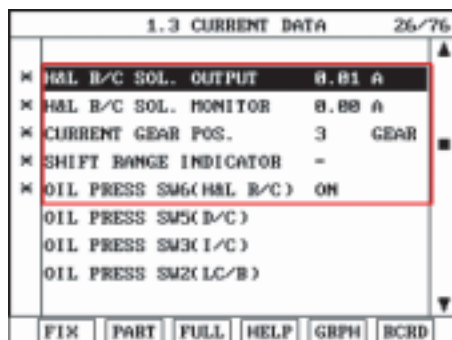

FIG.6)

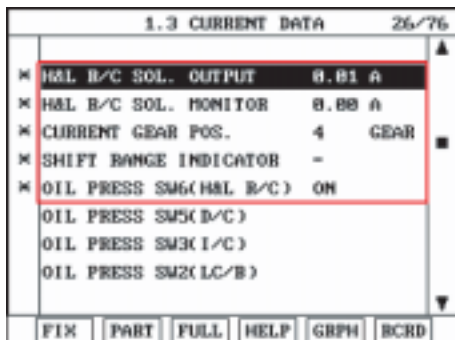

FIG.7)

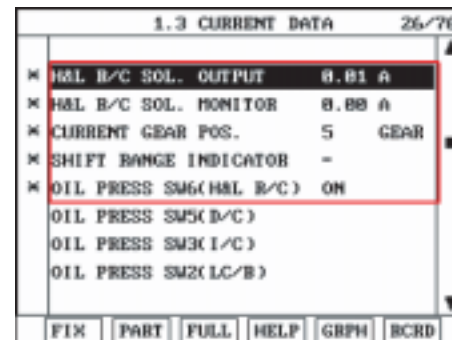

FIG.8)

FIG.1) "P" Range

FIG.2) "R" Shifting

FIG.3) "N" Range

FIG.4) "D" Range 1st gear

FIG.5) "D" Range 2nd gear

FIG.6) "D" Range 3rd gear

FIG.7) "D" Range 4th gear

FIG.8) "D" Range 5th gear

6. Does "H & LR/C SOLENOID" follow the reference data?

YES

Fault is intermittent caused by poor contact in the sensor's and/or PCM/TCM's connector or was repaired and PCM/TCM memory was not cleared. Thoroughly check connectors for looseness, poor connection, bending, corrosion, contamination, deterioration or damage. Repair or replace as necessary and go to "Verification of Vehicle Repair" procedure.

NO

Go to "Terminal & connector inspection " procedure.

TERMINAL & CONNECTOR INSPECTION EF2003DF

Refer to DTC P0741.

SIGNAL CIRCUIT INSPECTION E713F2D8

1. Disconnect "C06-2/C106-2" connector.
2. IGNITION "ON", ENGINE "OFF"
3. Measure voltage between terminal "3" of the C06-2/C106-2 harness connector and chassis ground.

Specification : Output voltage repeated between 4V and 12V

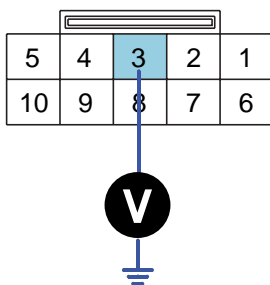

C06-2 [DSL 2.5]
C106-2 [GSL 3.3/3.8]

1. ATF 2
2. LOW COAST BRAKE SOLENOID VALVE
3. **HIGH&LOW REVERSE CLUTCH SOLENOID VALVE**
4. DIRECT CLUTCH SOLENOID VALVE
6. FRONT BRAKE SOLENOID VALVE
7. INPUT CLUTCH SOLENOID VALVE
8. PCSV(LINE PRESSURE CONTROL SOLENOID VALVE)
9. TCCSV

SBLAT6178L

4. Is voltage within specifications?

YES

Go to "Component inspection" procedure.

NO

Check for open or short in harness. Repair as necessary and Go to "Verification of Vehicle Repair" procedure. If signal circuit in harness is OK, Substitute with a known-good TCM and check for proper operation. If the problem is corrected, replace TCM as necessary and go to "Verification of Vehicle Repair" procedure.

AUTOMATIC TRANSAXLE SYSTEM

AT -167

COMPONENT INSPECTION

EAD87EEB

1. Disconnect "C06-2/C106-2" connector.
2. Ignition "OFF".
3. Measure resistance between terminal "3" of the C06-2/C106-2 harness connector and chassis ground.

Specification : approx. 3~9

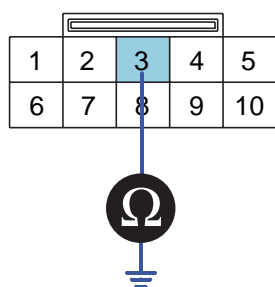

C06-2 [DSL 2.5]
C106-2 [GSL 3.3/3.8]
Component side

- 1.ATF 2
- 2.LOW COAST BRAKE SOLENOID VALVE
- 3.HIGH&LOW REVERSE CLUTCH SOLENOID VALVE**
- 4.DIRECT CLUTCH SOLENOID VALVE
- 6.FRONT BRAKE SOLENOID VALVE
- 7.INPUT CLUTCH SOLENOID VALVE
- 8.PCSV(LINE PRESSURE CONTROL SOLENOID VALVE)
- 9.TCCSV

SBLAT6179L

4. Is resistance within specifications?

YES

Thoroughly check connectors for looseness, poor connection, bending, corrosion, contamination, deterioration, or damage. Repair or replace as necessary and then go to "Verification of Vehicle Repair" procedure.

NO

5. Check for open or short in harness. Repair as necessary and Go to "Verification of Vehicle Repair" procedure. If signal circuit in harness is OK, Replace "H & LR/C SOLENOID VALVE" as necessary and Go to "Verification of Vehicle Repair" procedure.

VERIFICATION OF VEHICLE REPAIR

EB7FC6A8

Refer to DTC P0741.

DTC P0772 SHIFT SOLENOID "E(LC/B SOLENOID)" PERFORMANCE OR STUCK OFF

COMPONENT LOCATION E7BE6B2E

Refer to DTC P0743.

GENERAL DESCRIPTION EACA2B8E

Low coast brake solenoid valve is turned "ON" or "OFF" by the TCM in response to signals sent from the inhibitor switch, vehicle speed sensor and accelerator pedal position sensor (throttle position sensor). Gears will then be shifted to the optimum position.

DTC DESCRIPTION E1BEB364

This is not only caused by electrical malfunction (circuits open or shorted) but also by mechanical malfunction such as control valve sticking, improper solenoid valve operation.

DTC DETECTING CONDITION E2FAF7A4

Item	Detecting Condition	Possible cause
DTC Strategy	<ul style="list-style-type: none">• Rationality check (stuck-on)	LOW COAST BRAKE SOLENOID VALVE: LC/B SOLENOID VALVE <ul style="list-style-type: none">• Open or short in circuit• Faulty LC/B SOLENOID VALVE• Faulty TCM
Enable Conditions	<ul style="list-style-type: none">• Vehicle speed 6.2MPH(10km/h)• Engine speed > 305 rpm• A/T range switch is D range• A/T flued temperature -40°F	
Threshold value	<ul style="list-style-type: none">• Fluid pressure switch E "ON" when the monitoring value is "OFF".	
Diagnostic Time	<ul style="list-style-type: none">• A/T flued temperature > 14°F : More then 2secs• A/T flued temperature 14°F : More then 8secs	
Fail Safe	<ul style="list-style-type: none">• Locked into 2nd gear.	

MONITOR SCANTOOL DATA ED2148F5

1. Connect scantool to data link connector(DLC).
2. Engine "ON".
3. Monitor the "LC/B SOLENOID" parameter on the scantool.
4. Select "D RANGE" and Operate the vehicle.
5. Check "LC/B SOLENOID" parameter value changes while driving.

1.3 CURRENT DATA		28/76
LC/B SOLENOID	OFF	
LC/B SOL. MONITOR	ON	
CURRENT GEAR POS.	1 GEAR	
SHIFT RANGE INDICATOR	P	
OIL PRESS SW2(LC/B)	OFF	
OIL PRESS SW1(FR/B)		
BRAKE SWITCH		
REVERSE LAMP		

FIG.1)

1.3 CURRENT DATA		28/76
LC/B SOLENOID	OFF	
LC/B SOL. MONITOR	ON	
CURRENT GEAR POS.	1 GEAR	
SHIFT RANGE INDICATOR	R	
OIL PRESS SW2(LC/B)	OFF	
OIL PRESS SW1(FR/B)		
BRAKE SWITCH		
REVERSE LAMP		

FIG.2)

1.3 CURRENT DATA		28/76
LC/B SOLENOID	OFF	
LC/B SOL. MONITOR	ON	
CURRENT GEAR POS.	1 GEAR	
SHIFT RANGE INDICATOR	N	
OIL PRESS SW2(LC/B)	OFF	
OIL PRESS SW1(FR/B)		
BRAKE SWITCH		
REVERSE LAMP		

FIG.3)

1.3 CURRENT DATA		28/76
LC/B SOLENOID	OFF	
LC/B SOL. MONITOR	ON	
CURRENT GEAR POS.	1 GEAR	
SHIFT RANGE INDICATOR	D	
OIL PRESS SW2(LC/B)	OFF	
OIL PRESS SW1(FR/B)		
BRAKE SWITCH		
REVERSE LAMP		

FIG.4)

1.3 CURRENT DATA		28/76
LC/B SOLENOID	ON	
LC/B SOL. MONITOR	OFF	
CURRENT GEAR POS.	2 GEAR	
SHIFT RANGE INDICATOR	-	
OIL PRESS SW2(LC/B)	ON	
OIL PRESS SW1(FR/B)		
BRAKE SWITCH		
REVERSE LAMP		

FIG.5)

1.3 CURRENT DATA		28/76
LC/B SOLENOID	OFF	
LC/B SOL. MONITOR	ON	
CURRENT GEAR POS.	3 GEAR	
SHIFT RANGE INDICATOR	-	
OIL PRESS SW2(LC/B)	OFF	
OIL PRESS SW1(FR/B)		
BRAKE SWITCH		
REVERSE LAMP		

FIG.6)

1.3 CURRENT DATA		28/76
LC/B SOLENOID	OFF	
LC/B SOL. MONITOR	ON	
CURRENT GEAR POS.	4 GEAR	
SHIFT RANGE INDICATOR	-	
OIL PRESS SW2(LC/B)	OFF	
OIL PRESS SW1(FR/B)		
BRAKE SWITCH		
REVERSE LAMP		

FIG.7)

1.3 CURRENT DATA		28/76
LC/B SOLENOID	OFF	
LC/B SOL. MONITOR	ON	
CURRENT GEAR POS.	5 GEAR	
SHIFT RANGE INDICATOR	-	
OIL PRESS SW2(LC/B)	OFF	
OIL PRESS SW1(FR/B)		
BRAKE SWITCH		
REVERSE LAMP		

FIG.8)

FIG.1) "P" Range

FIG.2) "R" Shifting

FIG.3) "N" Range

FIG.4) "D" Range 1st gear

FIG.5) "D" Range 2nd gear

FIG.6) "D" Range 3rd gear

FIG.7) "D" Range 4th gear

FIG.8) "D" Range 5th gear

6. Does "LC/B SOLENOID" follow the reference data?

YES

Fault is intermittent caused by poor contact in the sensor's and/or PCM/TCM's connector or was repaired and PCM/TCM memory was not cleared. Thoroughly check connectors for looseness, poor connection, bending, corrosion, contamination, deterioration or damage. Repair or replace as necessary and go to "Verification of Vehicle Repair" procedure.

NO

Go to "Terminal & connector inspection " procedure.

TERMINAL & CONNECTOR INSPECTION EAD731F9

Refer to DTC P0741.

SIGNAL CIRCUIT INSPECTION E4DC4C76

1. Disconnect "C06-2" connector.
2. IGNITION "ON", ENGINE "OFF"
3. Measure voltage between terminal "2" of the C06-2 harness connector and chassis ground.

Specification : approx. 12V

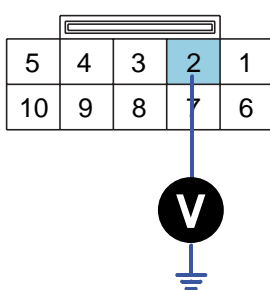

C06-2

1. ATF 2
2. **LOW COAST BRAKE SOLENOID VALVE**
3. HIGH&LOW REVERSE CLUTCH SOLENOID VALVE
4. DIRECT CLUTCH SOLENOID VALVE
6. FRONT BRAKE SOLENOID VALVE
7. INPUT CLUTCH SOLENOID VALVE
8. PCSV(LINE PRESSURE CONTROL SOLENOID VALVE)
9. TCCSV

SBLAT6181L

4. Is voltage within specifications?

YES

Go to "Component inspection" procedure.

NO

Check for open or short in harness. Repair as necessary and Go to "Verification of Vehicle Repair" procedure. If signal circuit in harness is OK, Substitute with a known-good TCM and check for proper operation. If the problem is corrected, replace TCM as necessary and go to "Verification of Vehicle Repair" procedure.

AUTOMATIC TRANSAXLE SYSTEM

AT -171

COMPONENT INSPECTION E2CAF248

1. Disconnect "C06-2" connector.
2. Ignition "OFF".
3. Measure resistance between terminal "2" of the C06-2 harness connector and chassis ground.

Specification : approx. 3~9

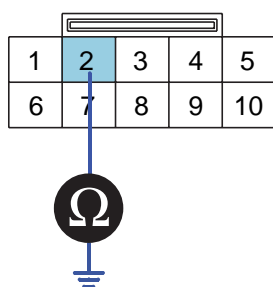

C06-2
Component side

- 1.ATF 2
- 2.LOW COAST BRAKE SOLENOID VALVE**
- 3.HIGH&LOW REVERSE CLUTCH SOLENOID VALVE
- 4.DIRECT CLUTCH SOLENOID VALVE
- 6.FRONT BRAKE SOLENOID VALVE
- 7.INPUT CLUTCH SOLENOID VALVE
- 8.PCSV(LINE PRESSURE CONTROL SOLENOID VALVE)
- 9.TCCSV

SBLAT6182L

4. Is resistance within specifications?

YES

Thoroughly check connectors for looseness, poor connection, bending, corrosion, contamination, deterioration, or damage. Repair or replace as necessary and then go to "Verification of Vehicle Repair" procedure.

NO

5. Check for open or short in harness. Repair as necessary and Go to "Verification of Vehicle Repair" procedure. If signal circuit in harness is OK, Replace "LC/B SOLENOID VALVE" as necessary and Go to "Verification of Vehicle Repair" procedure.

VERIFICATION OF VEHICLE REPAIR EBACF64D

Refer to DTC P0741.

DTC P0773 SHIFT SOLENOID "E(LC/B SOLENOID)" CIRCUIT - OPEN OR SHORT(GND)

COMPONENT LOCATION E1C18EAE

Refer to DTC P0743.

GENERAL DESCRIPTION E0B6F20D

Low coast brake solenoid valve is turned "ON" or "OFF" by the TCM in response to signals sent from the inhibitor witch, vehicle speed sensor and accelerator pedal position sensor (throttle position sensor). Gears will then be shifted to the optimum position.

DTC DESCRIPTION EACFA2FB

This is not only caused by electrical malfunction (circuits open or shorted) but also by mechanical malfunction such as control valve sticking, improper solenoid valve operation.

DTC DETECTING CONDITION E3E82AAB

[DSL 2.5]

Item	Detecting Condition	Possible cause
DTC Strategy	<ul style="list-style-type: none">Check voltage range	LOW COAST BRAKE SOLENOID VALVE: LC/B SOLENOID VALVE <ul style="list-style-type: none">Open or short in circuitFaulty LC/B SOLENOID VALVEFaulty TCM
Enable Conditions	<ul style="list-style-type: none">Vehicle speed 6.2MPH(10km/h)	
Threshold value	<ul style="list-style-type: none">Ground short/open :Monitoring value[ON/OFF] "OFF", When the driver output is "ON"B+ short:Monitoring value[ON/OFF] "OFF", When the driver output is "ON"	
Diagnostic Time	<ul style="list-style-type: none">more than 0.2sec	
Fail Safe	<ul style="list-style-type: none">Locked into 2nd gear.	

[GSL 3.3/3.8]

Item	Detecting Condition	Possible cause
DTC Strategy	<ul style="list-style-type: none">Check voltage range	LOW COAST BRAKE SOLENOID VALVE: LC/B SOLENOID VALVE <ul style="list-style-type: none">Open or short in circuitFaulty LC/B SOLENOID VALVEFaulty TCM
Enable Conditions	<ul style="list-style-type: none">10V < Actuator power supply voltage < 16V	
Threshold value	<ul style="list-style-type: none">Hardware "IC" check	
Diagnostic Time	<ul style="list-style-type: none">More than 0.2sec	
Fail Safe	<ul style="list-style-type: none">Lock-up control is prohibited(L/U off)	

MONITOR SCANTOOL DATA EADC0CE2

1. Connect scantool to data link connector(DLC).
2. Engine "ON".
3. Monitor the "LC/B SOLENOID" parameter on the scantool.
4. Select "D RANGE" and Operate the vehicle.

5. Check "LC/B SOLENOID" parameter value changes while driving.

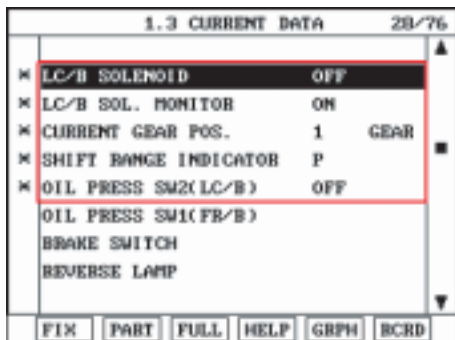

FIG.1)

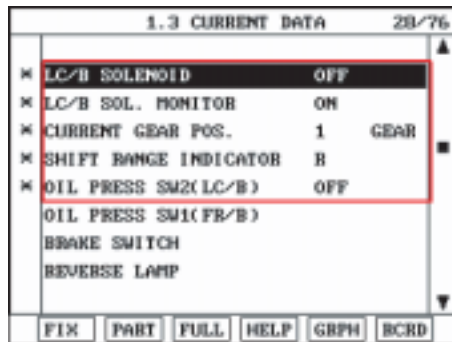

FIG.2)

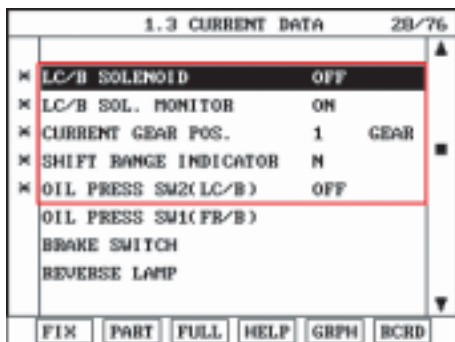

FIG.3)

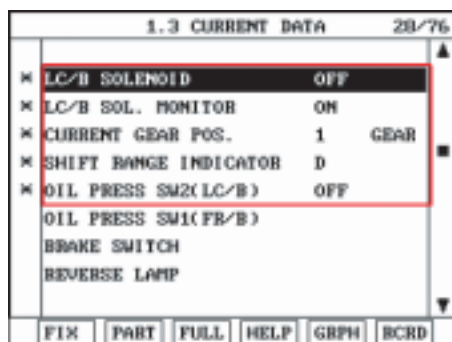

FIG.4)

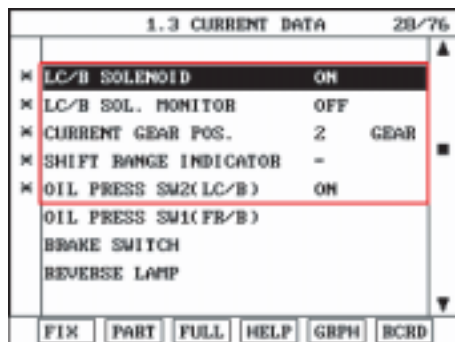

FIG.5)

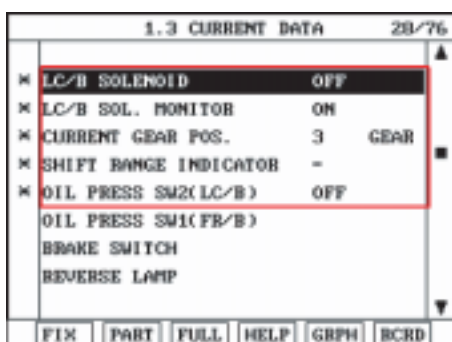

FIG.6)

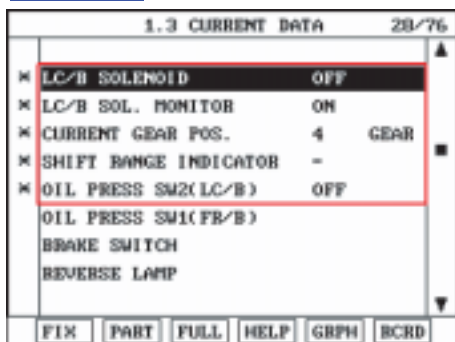

FIG.7)

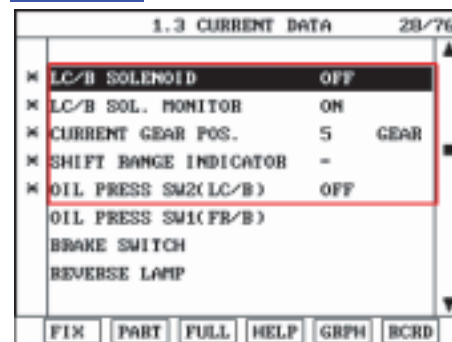

FIG.8)

FIG.1) "P" Range

FIG.2) "R" Shifting

FIG.3) "N" Range

FIG.4) "D" Range 1st gear

FIG.5) "D" Range 2nd gear

FIG.6) "D" Range 3rd gear

FIG.7) "D" Range 4th gear

FIG.8) "D" Range 5th gear

6. Does "LC/B SOLENOID" follow the reference data?

YES

Fault is intermittent caused by poor contact in the sensor's and/or PCM/TCM's connector or was repaired and PCM/TCM memory was not cleared. Thoroughly check connectors for looseness, poor connection, bending, corrosion, contamination, deterioration or damage. Repair or replace as necessary and go to "Verification of Vehicle Repair" procedure.

NO

Go to "Terminal & connector inspection " procedure.

TERMINAL & CONNECTOR INSPECTION E6B9BF4C

Refer to DTC P0741.

SIGNAL CIRCUIT INSPECTION E8F6CBDA

1. Disconnect "C06-2/C106-2" connector.
2. IGNITION "ON", ENGINE "OFF"
3. Measure voltage between terminal "2" of the C06-2/C106-2 harness connector and chassis ground.

Specification : approx. 12V

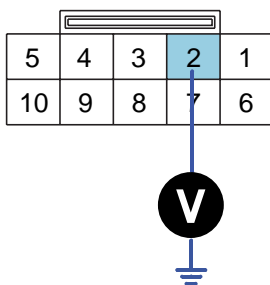

C06-2 [DSL 2.5]
C106-2 [GSL 3.3/3.8]

1. ATF 2
2. **LOW COAST BRAKE SOLENOID VALVE**
3. HIGH&LOW REVERSE CLUTCH SOLENOID VALVE
4. DIRECT CLUTCH SOLENOID VALVE
6. FRONT BRAKE SOLENOID VALVE
7. INPUT CLUTCH SOLENOID VALVE
8. PCSV(LINE PRESSURE CONTROL SOLENOID VALVE)
9. TCCSV

SBLAT6183L

4. Is voltage within specifications?

YES

Go to "Component inspection" procedure.

NO

Check for open or short in harness. Repair as necessary and Go to "Verification of Vehicle Repair" procedure. If signal circuit in harness is OK, Substitute with a known-good TCM and check for proper operation. If the problem is corrected, replace TCM as necessary and go to "Verification of Vehicle Repair" procedure.

AUTOMATIC TRANSAXLE SYSTEM

AT -175

COMPONENT INSPECTION EAC24C9F

1. Disconnect "C06-2/C106-2" connector.
2. Ignition "OFF".
3. Measure resistance between terminal "2" of the C06-2/C106-2 harness connector and chassis ground.

Specification : approx. 3~9

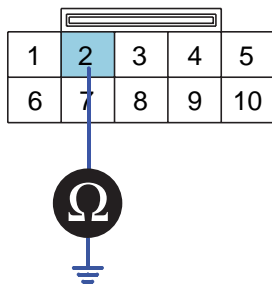

C06-2 [DSL 2.5]
C106-2 [GSL 3.3/3.8]
Component side

- 1.ATF 2
- 2.LOW COAST BRAKE SOLENOID VALVE**
- 3.HIGH&LOW REVERSE CLUTCH SOLENOID VALVE
- 4.DIRECT CLUTCH SOLENOID VALVE
- 6.FRONT BRAKE SOLENOID VALVE
- 7.INPUT CLUTCH SOLENOID VALVE
- 8.PCSV(LINE PRESSURE CONTROL SOLENOID VALVE)
- 9.TCCSV

SBLAT6184L

4. Is resistance within specifications?

YES

Thoroughly check connectors for looseness, poor connection, bending, corrosion, contamination, deterioration, or damage. Repair or replace as necessary and then go to "Verification of Vehicle Repair" procedure.

NO

5. Check for open or short in harness. Repair as necessary and Go to "Verification of Vehicle Repair" procedure. If signal circuit in harness is OK, Replace "LC/B SOLENOID VALVE" as necessary and Go to "Verification of Vehicle Repair" procedure.

VERIFICATION OF VEHICLE REPAIR E228C4C4

Refer to DTC P0741.

DTC P0819 UP AND DOWN SHIFT SWITCH TO TRANSMISSION RANGE CORRELATION

COMPONENT LOCATION E08ECECE

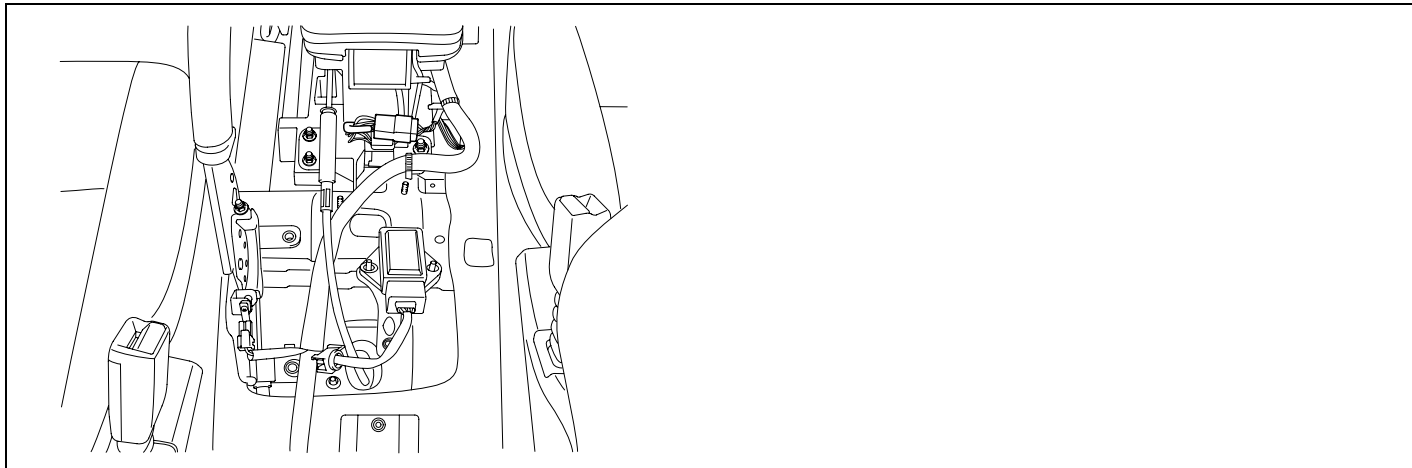

SBLAT6260L

GENERAL DESCRIPTION EDB6B87B

The TRANSMISSION Range Switch sends the shift lever position information to the TCM using a 5V signal. Deciding each TCM range depend on 4 s/w signal. Standard patterns are fixed and these patterns are on the Specification table as listed below. For example, when s/w 1,2,4 are 'ON(0V)' and s/w 3 is 'OFF(5V)', TCM recognizes 'D Range'. When the shift lever is in the D (Drive) position the output signal of Tansaxle Range Switch is 12V and in all other positions the voltage is 0V. The TCM judges the shift lever position by reading all signals, for the TRANSMISSION Range Switch, simultaneously.

DTC DESCRIPTION E9B3A463

The TCM sets this code when patterns are without Specification of the table shown below. The TRANSMISSION Range Switch has no output signal for an extended period of time.

DTC DETECTING CONDITION EDA4D8CD

Item	Detecting Condition	Possible cause
DTC Strategy	<ul style="list-style-type: none">• Rationality	<ul style="list-style-type: none">• OPEN OR SHORT IN CIRCUIT• Faulty TRANSMISSION RANGE SWITCH• Faulty TCM
Enable Conditions	<ul style="list-style-type: none">• Battery voltage > 10V	
Threshold value	<ul style="list-style-type: none">• Abnormal input signal is detected.	
Diagnostic Time	<ul style="list-style-type: none">• More than 5sec	
Fail Safe	<ul style="list-style-type: none">• Prevention of manual shift	

AUTOMATIC TRANSAXLE SYSTEM

SPECIFICATION E4B11ACD

A/T RANGE PATTERN

A/T range switch				Range swsitch	Remarks
SW1	SW2	SW3	SW4		
OFF	OFF	OFF	OFF	Pst	P start
OFF	OFF	ON	OFF	P	P
OFF	OFF	ON	ON	P-R	Intermediate
ON	OFF	ON	ON	R	R
ON	OFF	ON	OFF	N-R	Intermediate
ON	OFF	OFF	OFF	Nst	N start
ON	OFF	OFF	ON	N-D	Intermediate
ON	ON	OFF	ON	D	D
OFF	ON	OFF	ON	3	3
OFF	ON	ON	ON	2	2
OFF	ON	ON	OFF	1	1
Irregular Pattern				Other	

[OFF= 5V, ON = 0V]

MONITOR SCANTOOL DATA EED1BC3A

1. Connect scantool to data link connector(DLC).
2. Ignition "ON" & Engine "OFF".
3. Monitor the "SPORTS MODE SELECT S/W, SPORTS MODE UP S/W, SPORTS MODE DOWN S/W " parameter on the scantool.
4. Move selector lever to "SPORTS MODE".

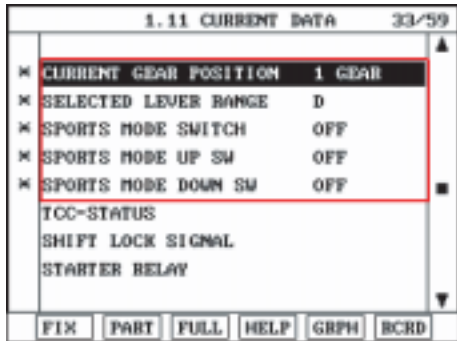

FIG.1)

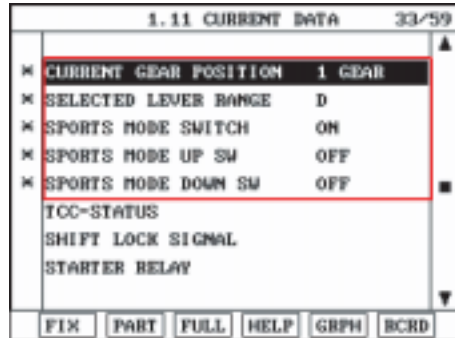

FIG.2)

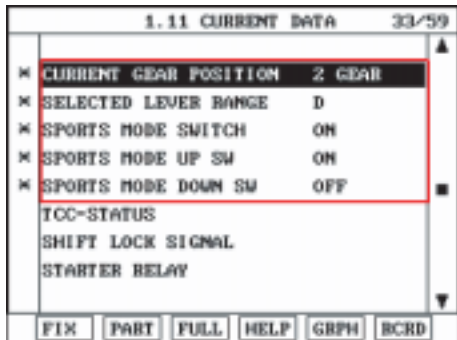

FIG.3)

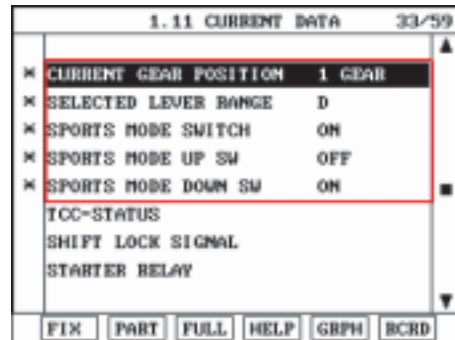

FIG.4)

FIG.1) "D" RANGE

FIG.2) "SPORTS MODE ON"

FIG.3) "UP S/W ON"

FIG.4) "DOWN S/W ON"

SBLAT6261L

5. Does "SPORTS MODE SELECT S/W" follow the reference data?

YES

Fault is intermittent caused by poor contact in the sensor's and/or PCM/TCM's connector or was repaired and PCM/TCM memory was not cleared. Thoroughly check connectors for looseness, poor connection, bending, corrosion, contamination, deterioration or damage. Repair or replace as necessary and go to "Verification of Vehicle Repair" procedure.

NO

Go to "Terminal & connector inspection" procedure.

AUTOMATIC TRANSAXLE SYSTEM

AT -179

TERMINAL & CONNECTOR INSPECTION E53F5C7B

1. Many malfunctions in the electrical system are caused by poor harness and terminals. Faults can also be caused by interference from other electrical systems, and mechanical or chemical damage.
2. Thoroughly check connectors for looseness, poor connection, bending, corrosion, contamination, deterioration, or damage.
3. Has a problem been found?

YES

Repair as necessary and go to "Verification of vehicle Repair" procedure.

NO

Go to "Power supply circuit inspection" procedure.

POWER SUPPLY CIRCUIT INSPECTION E02F04AB

1. Connect "M62" connector.
2. Ignition "ON" & Engine "OFF"
3. Measure voltage between terminal "2" of the "M62" connector and chassis ground.

Specification : approx. 12V

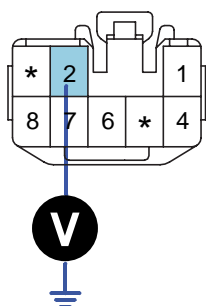

M62

1. ILLUMINATION
2. POWER SUPPLY
4. ILLUMINATION
6. UP SHIFT
7. SELECT SWITCH
8. DOWN SHIFT

SBLAT6262L

4. Is voltage within specifications?

YES

Go to "Signal circuit inspection" procedure.

NO

Check for open or short in harness and Fuse. Repair as necessary and Go to "Verification of Vehicle Repair" procedure.

SIGNAL CIRCUIT INSPECTION EFD6D86A

1. Connect "M62" connector.
2. Ignition "ON" & Engine "OFF".
3. Move select lever to "SPORTS MODE" and operate select lever to up and down.

4. Measure voltage between terminal "6, 7, 8" of the "M62" connector and chassis ground

Specification : approx. 12V

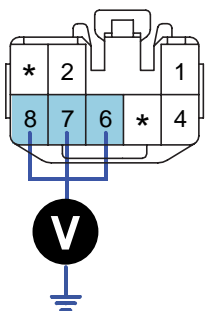

M62

- 1. ILLUMINATION
- 2. POWER SUPPLY
- 4. ILLUMINATION
- 6. UP SHIFT
- 7. SELECT SWITCH
- 8. DOWN SHIFT

SBLAT6263L

5. Is voltage within specifications?

YES

Go to "Component inspection" procedure.

NO

Substitute with a known-good "SPORTS MODE SWITCH" and check for proper operation. If the problem is corrected, replace "SPORTS MODE SWITCH" and Go to "Verification Vehicle Repair" procedure.

COMPONENT INSPECTION

ED50251F

- 1. Connect "TCU" connector.
- 2. Ignition "ON" & Engine "OFF".
- 3. Move select lever to "SPORTS MODE" and operate select lever to up and down.
- 4. Measure voltage between terminal "16, 17, 61" of the "TCU" connector(C120) and chassis ground.

Specification : approx. 12V

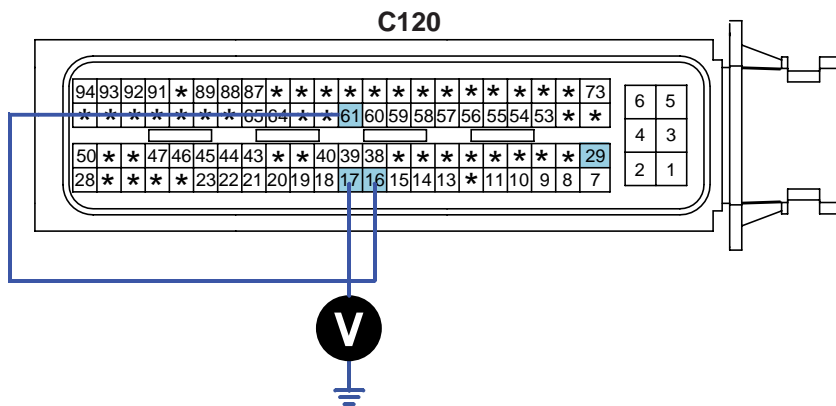

C120

- 16. UP shift
- 17. DOWN shift
- 61. MODE SELECT switch

SBLAT6264L

5. Is voltage within specifications?

YES

Substitute with a known-good "TCU" and check for proper operation. If the problem is corrected, replace "TCU" and Go to "Verification of Vehicle Repair" procedure.

NO

Check for open or short between "M62" and "C120" harness . Repair as necessary and Go to "Verification of Vehicle Repair" procedure.

VERIFICATION OF VEHICLE REPAIR E6DBDFC6

After a repair, it is essential to verify that the fault has been corrected.

1. Connect scantool and select "Diagnostic Trouble Codes(DTCs)" mode.
2. Using a scantool, Clear DTC.
3. Operate the vehicle within DTC Enable conditions in General information.
4. Are any DTCs present?

YES

Go to the applicable troubleshooting procedure.

NO

System performing to specification at this time.

DTC P0863 CAN COMMUNICATION BUS OFF

COMPONENT LOCATION ED4D6E2D

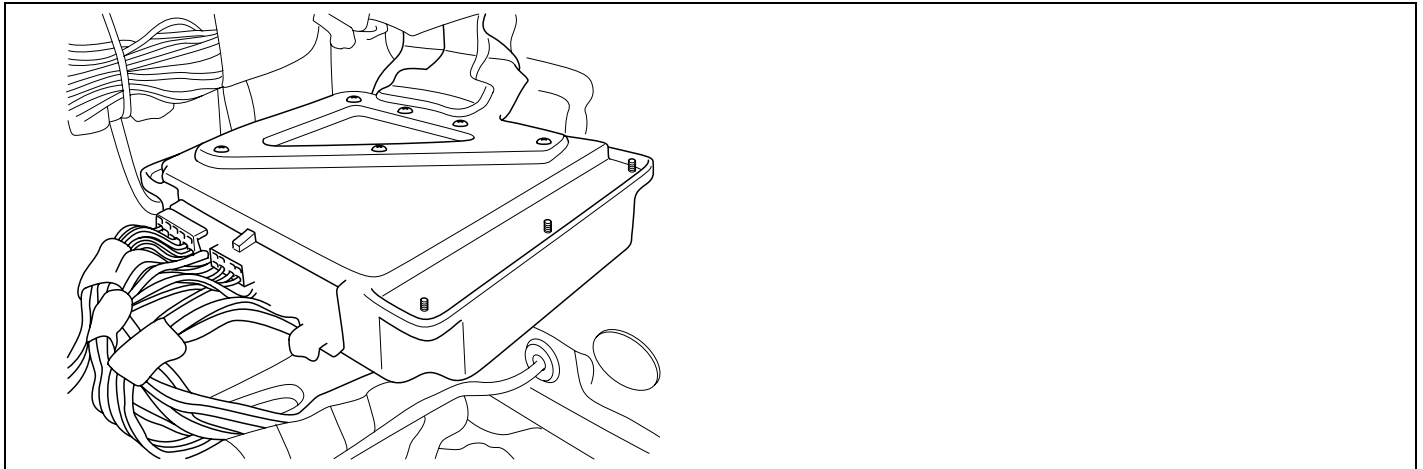

SBLAT6190L

GENERAL DESCRIPTION E88DD748

The TCM can either receive data from the Engine Control Module or ABS control module, or it can send data to the ECM and ABSCM by using CAN communication. The CAN communication is one of the vehicle communication methods, which is now widely used to transfer the vehicle data.

DTC DESCRIPTION E0CC7F83

CAN (Controller Area Network) is a serial communication line for real time application. It is an on-vehicle multiplex communication line with high data communication speed and excellent malfunction detection ability. Many electronic control units are equipped on a vehicle, and each control unit shares information and links with other control units during operation (not independent). In CAN communication, control units are connected with 2 communication lines (CAN H line, CAN L line) allowing a high rate of information transmission with less wiring. Each control unit transmits/receives data but selectively reads required data only.

DTC DETECTING CONDITION E0E9AE75

Item	Detecting Condition	Possible cause
DTC Strategy	<ul style="list-style-type: none">• Check voltage range	<ul style="list-style-type: none">• Open or Short in CAN communication harness• Faulty ECM• Faulty TCM
Enable Conditions	<ul style="list-style-type: none">• CONTINUOUS	
Threshold value	<ul style="list-style-type: none">• No signal transmitted at CAN module	
Diagnostic Time	<ul style="list-style-type: none">• More than 2sec	
Fail Safe	<ul style="list-style-type: none">• CAN COMMUNICATION IS INHIBITED.	

SIGNAL WAVEFORM E5102DC2

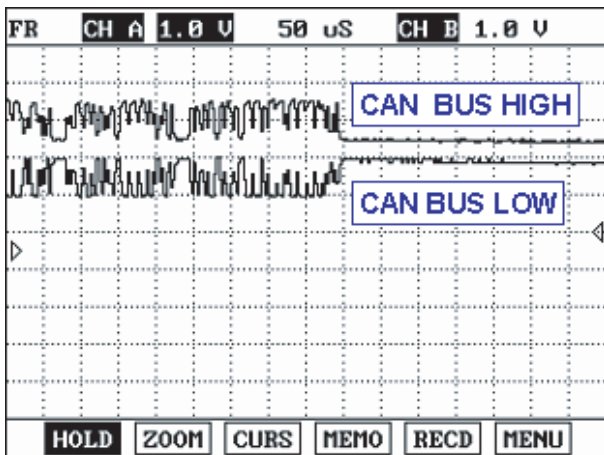

SBLAT6191L

MONITOR SCANTOOL DATA E1EBCBD1

1. Connect scantool to data link connector(DLC).
2. Engine "ON".
3. Monitor the "CAN COMMUNICATION SERVICE DATA (ENGINE RPM, VEHICLE SPEED SENSOR, THROTTLE P. SENSOR)" parameters on the scantool.

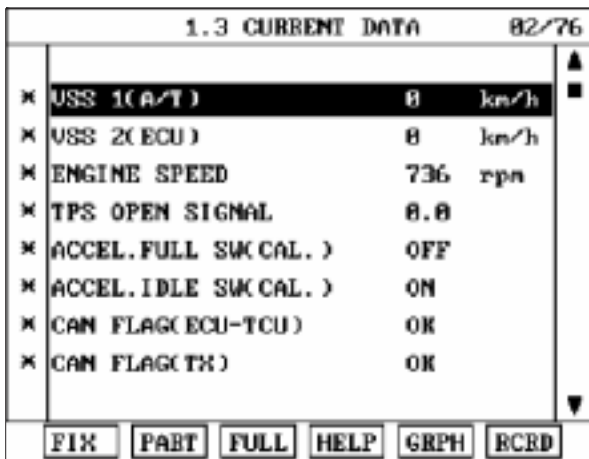

FIG.1)

FIG.1) LOW - SPEED
FIG.2) HIGH - SPEED

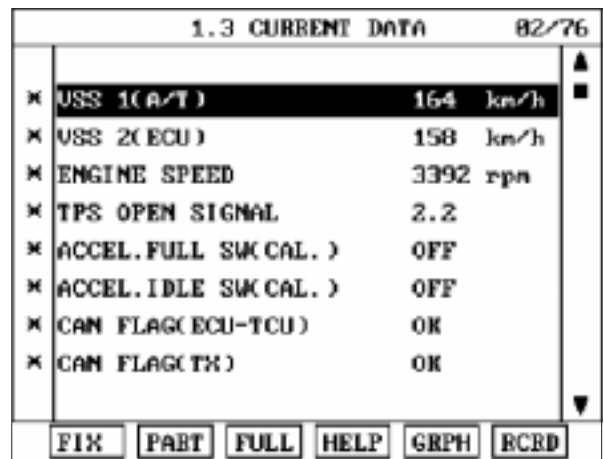

FIG.2)

SBLAT6192L

4. Does "CAN BUS LINE DATA" follow the reference data?

YES

Fault is intermittent caused by poor contact in the sensor's and/or PCM/TCM's connector or was repaired and PCM/TCM memory was not cleared.And go to Verification of Vehicle Repair procedure.

NO

Go to "Terminal & connector inspection " procedure.

TERMINAL & CONNECTOR INSPECTION E5B271E5

1. Many malfunctions in the electrical system are caused by poor harness and terminals. Faults can also be caused by interference from other electrical systems, and mechanical or chemical damage.
2. Thoroughly check connectors for looseness, poor connection, bending, corrosion, contamination, deterioration, or damage.
3. Has a problem been found?

YES

Repair as necessary and then go to "Verification of vehicle repair" procedure.

NO

Go to "Signal circuit Inspection" procedure.

SIGNAL CIRCUIT INSPECTION E67FEB95

1. Ignition "OFF".
2. Disconnect the "TCM" connector.
3. Measure resistance between terminal "6" and "7" of the "TCM" harness connector.

Specification : approx. 120

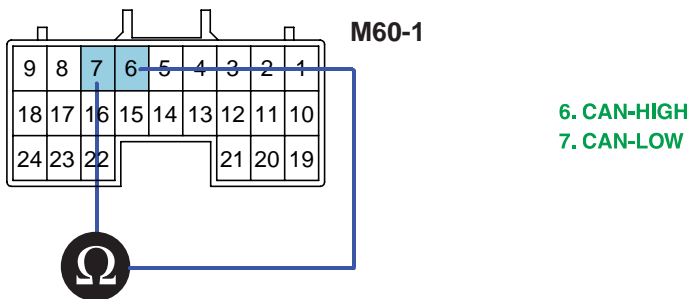

SBLAT6193L

4. Is measured resistance within specifications?

YES

Substitute with a known-good PCM/TCM and check for proper operation. If the problem is corrected, replace PCM/TCM as necessary and then go to "Verification of Vehicle Repair" procedure.

NO

Check connectors for looseness, poor connection, bending, corrosion, contamination, deterioration or damage of ECM. and then Repair or replace Resistance for CAN communication as necessary and go to "Verification of Vehicle Repair" procedure.

VERIFICATION OF VEHICLE REPAIR ECFDF4D0

After a repair, it is essential to verify that the fault has been corrected.

1. Connect scantool and select "Diagnostic Trouble Codes(DTCs)" mode.
2. Using a scantool, Clear DTC.
3. Operate the vehicle within DTC Enable conditions in General information.
4. Are any DTCs present?

YES

Go to the applicable troubleshooting procedure.

NO

System performing to specification at this time.

DTC P0893 MULTIPLE GEARS ENGAGED

COMPONENT LOCATION E1F1EB2C

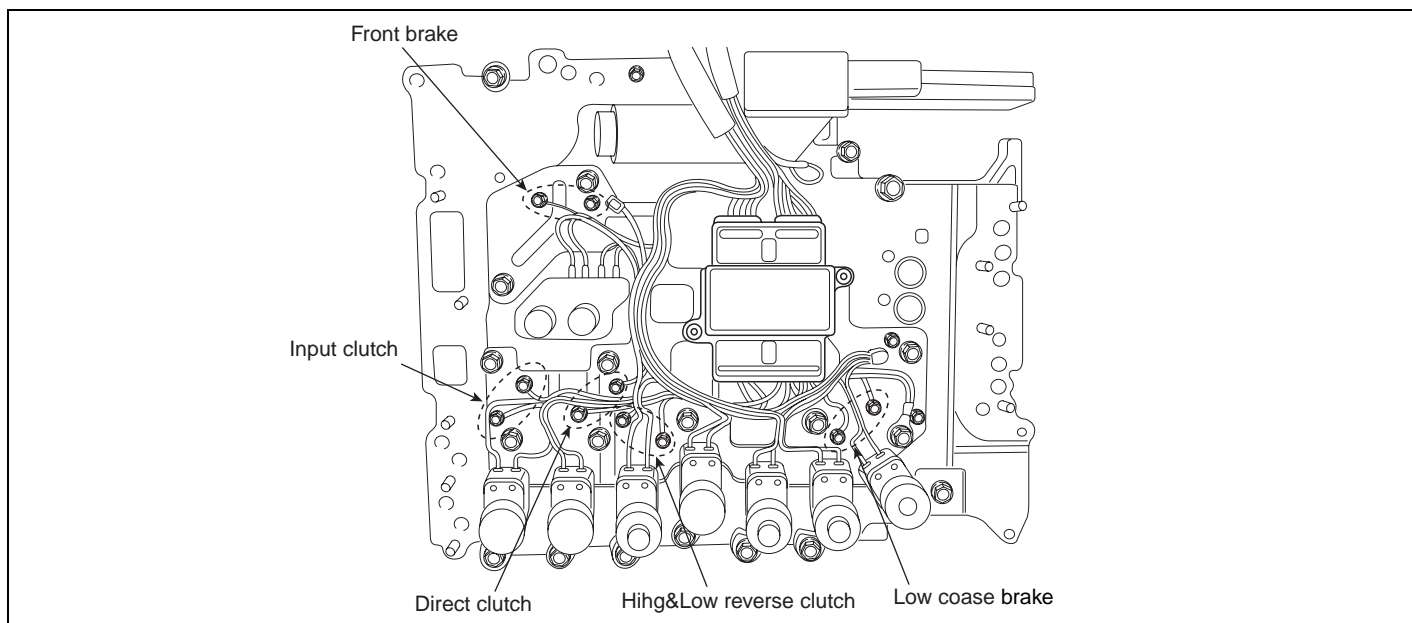

SBLAT6195L

GENERAL DESCRIPTION E3227EEB

While monitoring clutch engagement using Oil pressure switch of clutch pressure circuit, if abnormal Inter-lock engagement pattern is detected, 'Fail safe' mode is activated.

DTC DESCRIPTION EE2ACF8B

In case of abnormal shift pattern, the DTC-code is set(Refer to Specification as below).

DTC DETECTING CONDITION E1BFACA6

Item	Detecting Condition	Possible cause
DTC Strategy	<ul style="list-style-type: none"> • Check voltage range 	<ul style="list-style-type: none"> • Open or short in circuit • Faulty FLUID PRESSURE SWITCH E(H & LR/C) • Faulty SHIFT C/U
Enable Conditions	<ul style="list-style-type: none"> • Time after gear shifting 	
Threshold value	<ul style="list-style-type: none"> • Each fluid pressure switch agree with the patterns in fig.3 interlock 	
Diagnostic Time	<ul style="list-style-type: none"> • More then 2sec 	
Fail Safe	<ul style="list-style-type: none"> • Locked into 2nd or 4th or 5th gear. 	

SPECIFICATION E0DAB4A0

DETECTING PATTERN AND FAIL SAFE

■ : Don't care

④ Oil pressure ON/OFF

	RANGE	GEAR POSITION	PRESSURE SWITCH					Fail safe
			I/C	H&LR/C	D/C	Fr/B	LC/B	
INTER LOCK PATTERNS	D,4,3,2,1,M	1	●	○	■	○	○	Fixed at 4th gear
			■	○	●	■	○	Fixed at 4th gear
	2,M	2	■	●	○	■	○	Fixed at 4th gear
			●	■	○	○	■	Fixed at 4th gear
	D,4,3,M	3	■	○	○	■	●	Fixed at 2nd gear
			●	■	○	○	■	Fixed at 4th gear
	D,4,M	4	■	○	○	■	●	Fixed at 2nd gear
			○	■	○	●	■	Fixed at 5th gear
	D,M	5	○	○	■	○	●	Fixed at 2nd gear
			○	■	●	○	■	Fixed at 4th gear

SBLAT6196L

MONITOR SCANTOOL DATA E3AEE333

1. Connect scantool to data link connector(DLC).
2. Engine "ON".
3. Monitor the "FLUID PRESSURE SWITCH" parameter on the scantool.
4. Select "D RANGE or SPORTS MODE" and Operate the vehicle.
5. Check "FLUID PRESSURE SWITCH" parameter value changes while driving.

1.3 CURRENT DATA 34/76		1.3 CURRENT DATA 34/76	
* CURRENT GEAR POS.	1 GEAR	* CURRENT GEAR POS.	1 GEAR
* SELECTED LEVER RANGE	P, N	* SELECTED LEVER RANGE	R
* FLUID PRESSURE SW.- 6	ON	* FLUID PRESSURE SW.- 6	ON
* FLUID PRESSURE SW.- 5	OFF	* FLUID PRESSURE SW.- 5	OFF
* FLUID PRESSURE SW.- 3	OFF	* FLUID PRESSURE SW.- 3	OFF
* FLUID PRESSURE SW.- 2	OFF	* FLUID PRESSURE SW.- 2	OFF
* FLUID PRESSURE SW.- 1	ON	* FLUID PRESSURE SW.- 1	ON
INHIBITOR SW.- 2		BRAKE SWITCH	
FIX PART FULL HELP GRPH BCRD		FIX PART FULL HELP GRPH BCRD	

FIG.1)

FIG.2)

1.3 CURRENT DATA 34/76		1.3 CURRENT DATA 38/76	
* CURRENT GEAR POS.	1 GEAR	* CURRENT GEAR POS.	1 GEAR
* SELECTED LEVER RANGE	D	* SELECTED LEVER RANGE	SPORTS
* FLUID PRESSURE SW.- 6	OFF	* FLUID PRESSURE SW.- 6	ON
* FLUID PRESSURE SW.- 5	OFF	* FLUID PRESSURE SW.- 5	OFF
* FLUID PRESSURE SW.- 3	OFF	* FLUID PRESSURE SW.- 3	OFF
* FLUID PRESSURE SW.- 2	OFF	* FLUID PRESSURE SW.- 2	ON
* FLUID PRESSURE SW.- 1	ON	* FLUID PRESSURE SW.- 1	ON
INHIBITOR SW.- 2		BRAKE SWITCH	
FIX PART FULL HELP GRPH BCRD		FIX PART FULL HELP GRPH BCRD	

FIG.3)

FIG.4)

1.3 CURRENT DATA 38/76		1.3 CURRENT DATA 38/76	
* CURRENT GEAR POS.	2 GEAR	* CURRENT GEAR POS.	3 GEAR
* SELECTED LEVER RANGE	SPORTS	* SELECTED LEVER RANGE	SPORTS
* FLUID PRESSURE SW.- 6	OFF	* FLUID PRESSURE SW.- 6	ON
* FLUID PRESSURE SW.- 5	ON	* FLUID PRESSURE SW.- 5	ON
* FLUID PRESSURE SW.- 3	OFF	* FLUID PRESSURE SW.- 3	OFF
* FLUID PRESSURE SW.- 2	ON	* FLUID PRESSURE SW.- 2	OFF
* FLUID PRESSURE SW.- 1	ON	* FLUID PRESSURE SW.- 1	ON
BRAKE SWITCH		BRAKE SWITCH	
FIX PART FULL HELP GRPH BCRD		FIX PART FULL HELP GRPH BCRD	

FIG.5)

FIG.6)

1.3 CURRENT DATA 38/76		1.3 CURRENT DATA 38/76	
* CURRENT GEAR POS.	4 GEAR	* CURRENT GEAR POS.	5 GEAR
* SELECTED LEVER RANGE	SPORTS	* SELECTED LEVER RANGE	D
* FLUID PRESSURE SW.- 6	ON	* FLUID PRESSURE SW.- 6	ON
* FLUID PRESSURE SW.- 5	ON	* FLUID PRESSURE SW.- 5	OFF
* FLUID PRESSURE SW.- 3	ON	* FLUID PRESSURE SW.- 3	ON
* FLUID PRESSURE SW.- 2	OFF	* FLUID PRESSURE SW.- 2	OFF
* FLUID PRESSURE SW.- 1	OFF	* FLUID PRESSURE SW.- 1	ON
BRAKE SWITCH		BRAKE SWITCH	
FIX PART FULL HELP GRPH BCRD		FIX PART FULL HELP GRPH BCRD	

FIG.7)

FIG.8)

FIG.1) P/N RANGE

FIG.2) R RANGE

FIG.3) 1 GEAR(D RANGE)

FIG.4) 1 GEAR(S- MODE)

FIG.5) 2 GEAR(S- MODE)

FIG.6) 3 GEAR(S- MODE)

FIG.7) 4 GEAR(S- MODE)

FIG.8) 5 GEAR(D RANGE)

6. Does "FLUID PRESSURE SWITCH" follow the reference data?

YES

Fault is intermittent caused by poor contact in the sensor's and/or PCM/TCM's connector or was repaired and PCM/TCM memory was not cleared. Thoroughly check connectors for looseness, poor connection, bending, corrosion, contamination, deterioration or damage. Repair or replace as necessary and go to "Verification of Vehicle Repair" procedure.

NO

Substitute with a known-good "TRANSMISSION" and check for proper operation. If the problem is corrected, replace "TRANSMISSION" as necessary and go to "Verification of Vehicle Repair" procedure.

VERIFICATION OF VEHICLE REPAIR EC5E7FF0

After a repair, it is essential to verify that the fault has been corrected.

1. Connect scantool and select "Diagnostic Trouble Codes(DTCs)" mode.
2. Using a scantool, Clear DTC.
3. Operate the vehicle within DTC Enable conditions in General information.
4. Are any DTCs present?

YES

Go to the applicable troubleshooting procedure.

NO

System performing to specification at this time.

DTC U0001 CAN COMMUNICATION MALFUNCTION

COMPONENT LOCATION E0D5B52E

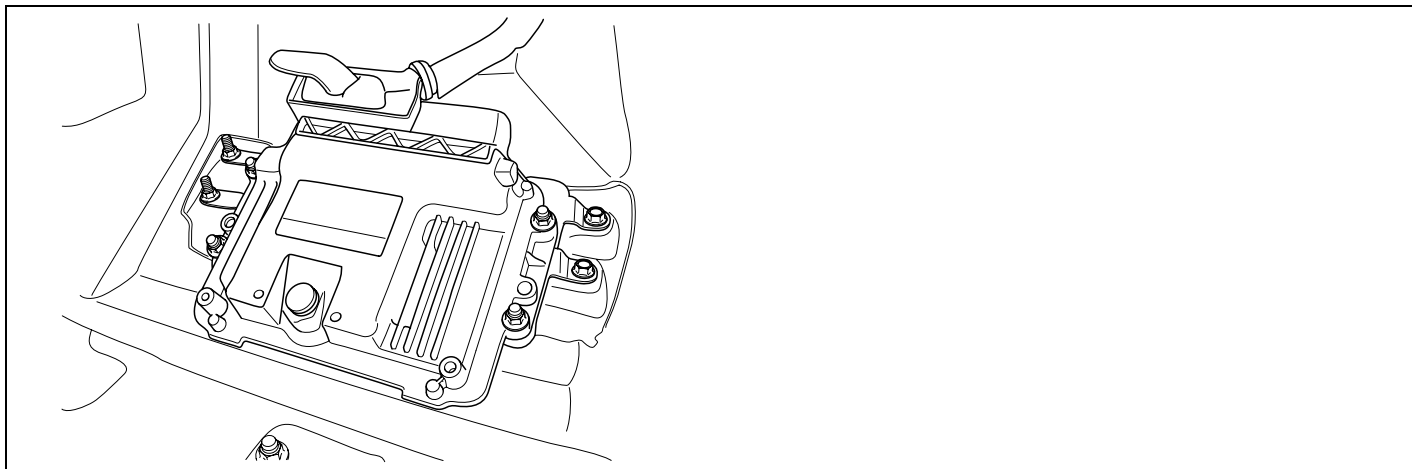

SBLAT6200L

GENERAL DESCRIPTION E8655262

The TCM can either receive data from the Engine Control Module or ABS control module, or it can send data to the ECM and ABSCM by using CAN communication. The CAN communication is one of the vehicle communication methods, which is now widely used to transfer the vehicle data.

DTC DESCRIPTION E38FE1EF

CAN (Controller Area Network) is a serial communication line for real time application. It is an on-vehicle multiplex communication line with high data communication speed and excellent malfunction detection ability. Many electronic control units are equipped on a vehicle, and each control unit shares information and links with other control units during operation (not independent). In CAN communication, control units are connected with 2 communication lines (CAN H line, CAN L line) allowing a high rate of information transmission with less wiring. Each control unit transmits/receives data but selectively reads required data only.

DTC DETECTING CONDITION ED49260F

Item	Detecting Condition	Possible cause
DTC Strategy	<ul style="list-style-type: none">• Check voltage range	<ul style="list-style-type: none">• Open or Short in CAN communication harness• Faulty ECM• Faulty TCM
Enable Conditions	<ul style="list-style-type: none">• IG "ON"• Battery voltage > 10V• Input speed > 300rpm	
Threshold value	<ul style="list-style-type: none">• BUS OFF	
Diagnostic Time	<ul style="list-style-type: none">• More than 2sec	
Fail Safe	<ul style="list-style-type: none">• Default value	

SIGNAL WAVEFORM EFAD777

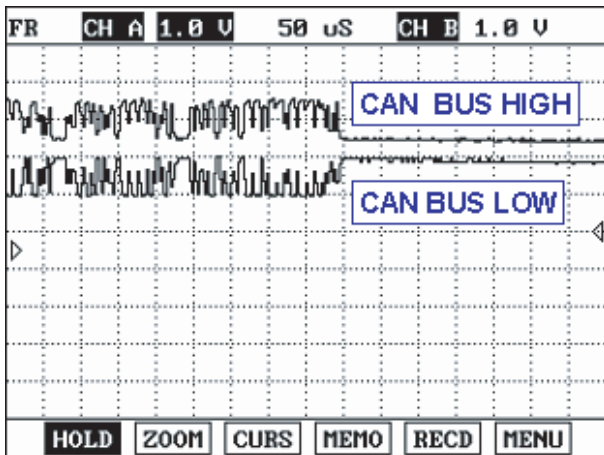

SBLAT6271L

MONITOR SCANTOOL DATA EF16E7FF

1. Connect scantool to data link connector(DLC).
2. Engine "ON".
3. Monitor the "CAN COMMUNICATION SERVICE DATA (ENGINE RPM, VEHICLE SPEED SENSOR, THROTTLE P. SENSOR)" parameters on the scantool.

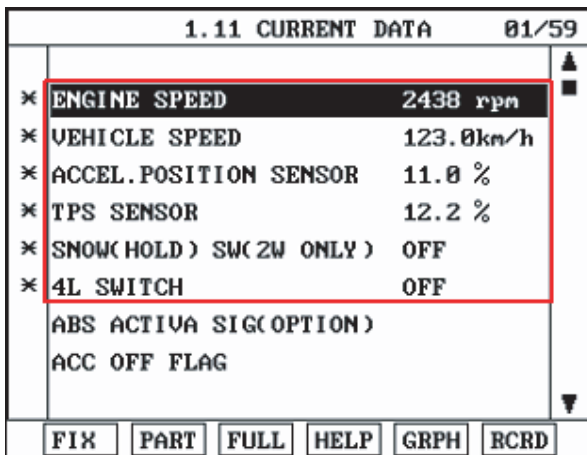

FIG.1)

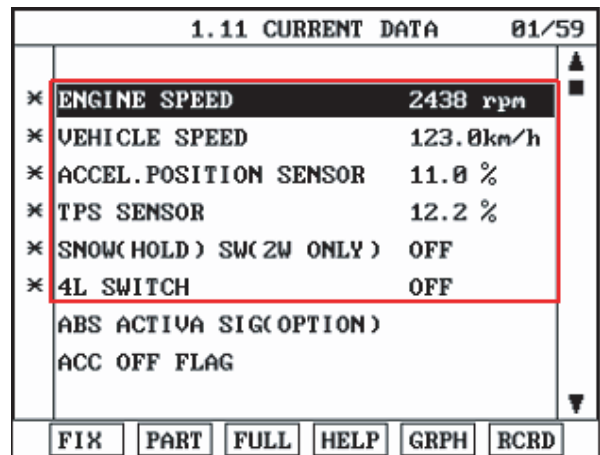

FIG.2)

FIG.1) Low-speed
FIG.2) High-speed

SBLAT6272L

4. Does "CAN BUS LINE DATA" follow the reference data?

YES

Fault is intermittent caused by poor contact in the sensor's and/or PCM/TCM's connector or was repaired and PCM/TCM memory was not cleared. Thoroughly check connectors for looseness, poor connection, bending, corrosion, contamination, deterioration or damage. Repair or replace as necessary and go to "Verification of Vehicle Repair" procedure.

NO

Go to "Terminal & connector inspection" procedure.

TERMINAL & CONNECTOR INSPECTION EF03DCD9

- 1. Many malfunctions in the electrical system are caused by poor harness and terminals. Faults can also be caused by interference from other electrical systems, and mechanical or chemical damage.
- 2. Thoroughly check connectors for looseness, poor connection, bending, corrosion, contamination, deterioration, or damage.
- 3. Has a problem been found?

YES

Repair as necessary and go to "Verification of Vehicle Repair" procedure.

NO

Go to "Signal circuit inspection" procedure.

SIGNAL CIRCUIT INSPECTION EDED579A

- 1. Ignition "OFF".
- 2. Disconnect the "TCM" connector.
- 3. Measure resistance between terminal "65" and "87" of the "TCM" harness connector.

Specification : Approx. 120

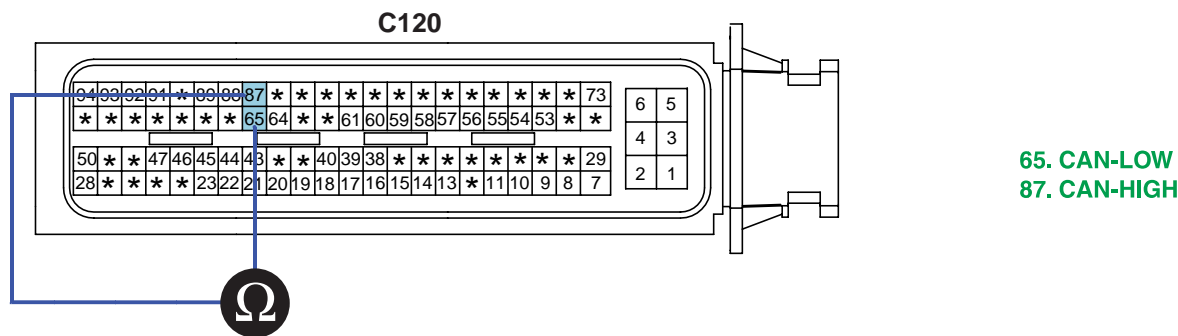

4. Is measured resistance within specifications?

YES

Substitute with a known-good PCM/TCM and check for proper operation. If the problem is corrected, replace PCM/TCM as necessary and then go to "Verification of Vehicle Repair" procedure.

NO

Check connectors for looseness, poor connection, bending, corrosion, contamination, deterioration or damage of ECM and then Repair or replace Resistance for CAN communication as necessary and go to "Verification of Vehicle Repair" procedure.

VERIFICATION OF VEHICLE REPAIR E9827A77

After a repair, it is essential to verify that the fault has been corrected.

1. Connect scantool and select "Diagnostic Trouble Codes(DTCs)" mode.
2. Using a scantool, Clear DTC.
3. Operate the vehicle within DTC Enable conditions in General information.
4. Are any DTCs present?

YES

Go to the applicable troubleshooting procedure.

NO

System performing to specification at this time.

AT -194

AUTOMATIC TRANSAXLE (A5SR1/2)

DTC U0100 CAN MI-COM OR CIRCUIT MAL

COMPONENT LOCATION E7AF6BEA

Refer to DTC U0001.

GENERAL DESCRIPTION EB222E33

Refer to DTC U0001.

DTC DESCRIPTION E6FAA1E6

Refer to DTC U0001.

DTC DETECTING CONDITION EFDF296B

Item	Detecting Condition	Possible cause
DTC Strategy	<ul style="list-style-type: none">• Check voltage range	<ul style="list-style-type: none">• Open or Short in CAN communication harness• Faulty ECM• Faulty TCM
Enable Conditions	<ul style="list-style-type: none">• IG "ON"• Battery voltage > 10V• Input speed > 300rpm	
Threshold value	<ul style="list-style-type: none">• Lost communication	
Diagnostic Time	<ul style="list-style-type: none">• More than 2sec	
Fail Safe	<ul style="list-style-type: none">• Default value	

SIGNAL WAVEFORM E21FF682

Refer to DTC U0001.

MONITOR SCANTOOL DATA EB8DD5EC

Refer to DTC U0001.

TERMINAL & CONNECTOR INSPECTION E4B893A1

Refer to DTC U0001.

SIGNAL CIRCUIT INSPECTION E8922226

Refer to DTC U0001.

VERIFICATION OF VEHICLE REPAIR E2474109

Refer to DTC U0001.

AUTOMATIC TRANSAXLE

COMPONENTS E7EE672D

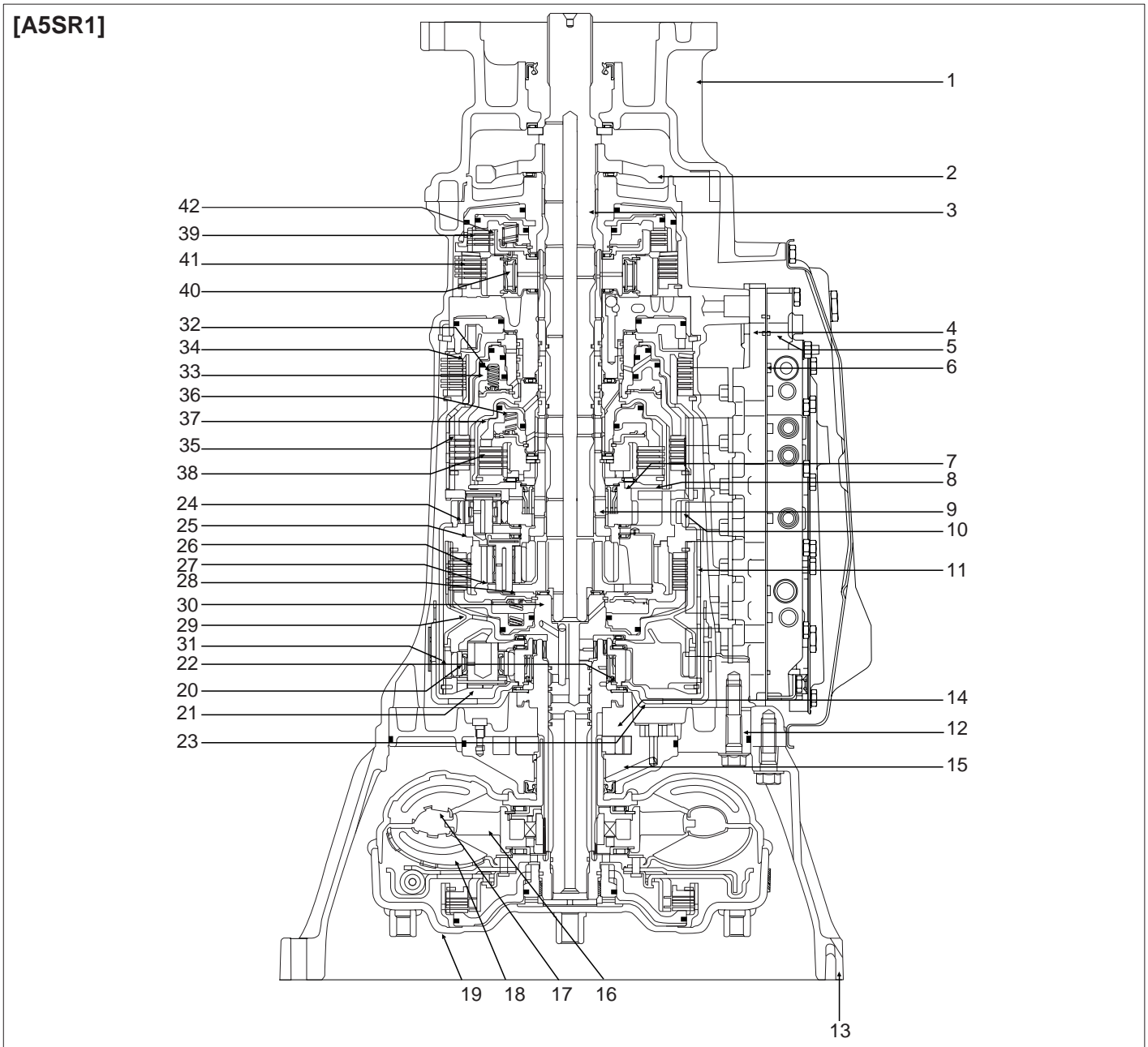

- | | | |
|---------------------------------|-------------------------------------|---|
| 1. Adapter case (4WD) | 15. Oil pump housing | 29. Input clutch drum |
| 2. Parking gear | 16. Stator | 30. Input shaft |
| 3. Output shaft | 17. Impeller assembly | 31. Front annulus gear |
| 4. Control valve upper body | 18. Turbine & lockup assembly | 32. Direct clutch return spring |
| 5. Control valve lower body | 19. Torque converter cover assembly | 33. Direct clutch piston |
| 6. Separator plate assembly | 20. Front pinion gear | 34. Reverse brake hub |
| 7. Rear sun gear | 21. Front planetary carrier | 35. Direct clutch assembly |
| 8. Rear sun plate | 22. Front sun gear | 36. High & low reverse clutch return spring |
| 9. Middle sun gear assembly | 23. Front brake drum | 37. High & low reverse clutch piston |
| 10. Rear annulus gear assembly | 24. Rear pinion gear | 38. High & low reverse clutch assembly |
| 11. Rear annulus cell | 25. Rear planetary carrier plate | 39. Low coast brake clutch assembly |
| 12. Automatic transmission case | 26. Middle annulus gear | 40. Forward one-way clutch |
| 13. Converter housing | 27. Middle pinion gear | 41. Forward brake clutch assembly |
| 14. Oil pump cover | 28. Middle planetary carrier | 42. Low coast brake hub |

[A5SR2]

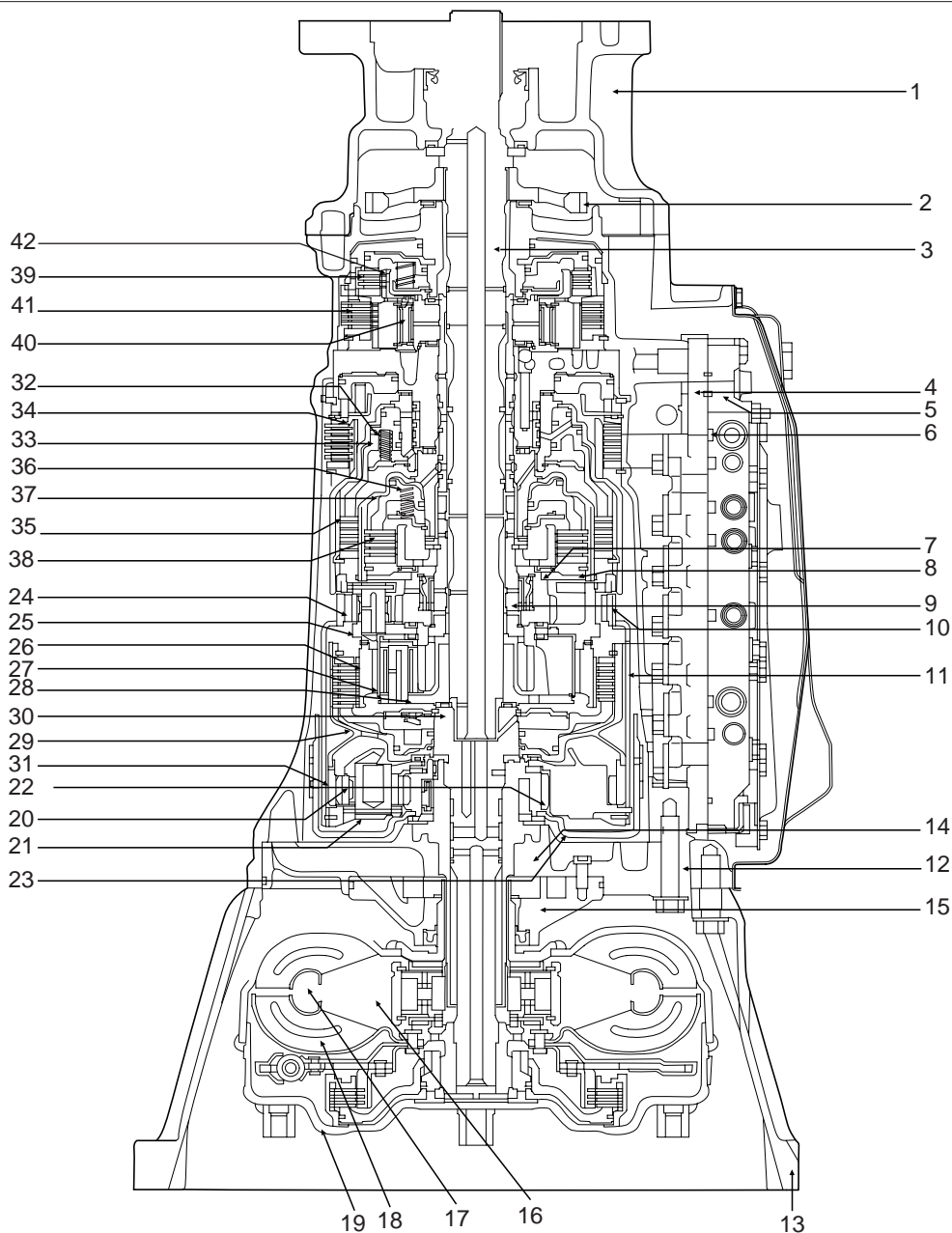

1. Adapter case (4WD)

2. Parking gear

3. Output shaft

4. Control valve upper body

5. Control valve lower body

6. Separator plate assembly

7. Rear sun gear

8. Rear sun plate

9. Middle sun gear assembly

10. Rear annulus gear assembly

11. Rear annulus cell

12. Automatic transmission case

13. Converter housing

14. Oil pump cover

15. Oil pump housing

16. Stator

17. Impeller assembly

18. Turbine & lockup assembly

19. Torque converter cover assembly

20. Front pinion gear

21. Front planetary carrier

22. Front sun gear

23. Front brake drum

24. Rear pinion gear

25. Rear planetary carrier plate

26. Middle annulus gear

27. Middle pinion gear

28. Middle planetary carrier

29. Input clutch drum

30. Input shaft

31. Front annulus gear

32. Direct clutch return spring

33. Direct clutch piston

34. Reverse brake hub

35. Direct clutch assembly

36. High & low reverse clutch return spring

37. High & low reverse clutch piston

38. High & low reverse clutch assembly

39. Low coast brake clutch assembly

40. Forward one-way clutch

41. Forward brake clutch assembly

42. Low coast brake hub

REMOVAL E57E1F3E

1. Remove the battery (-) terminal(A).

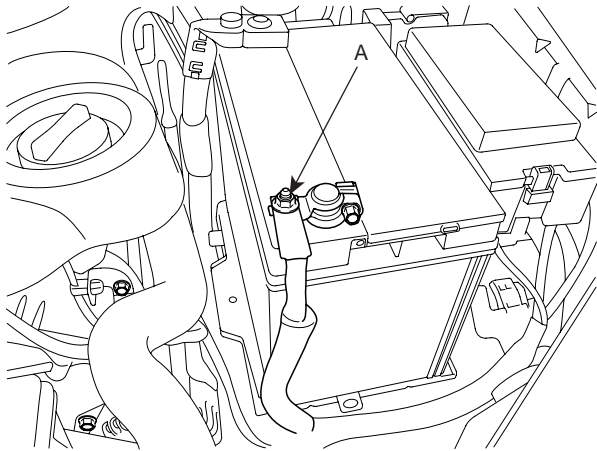

SBLAT6001L

2. Remove the engine cover(A).

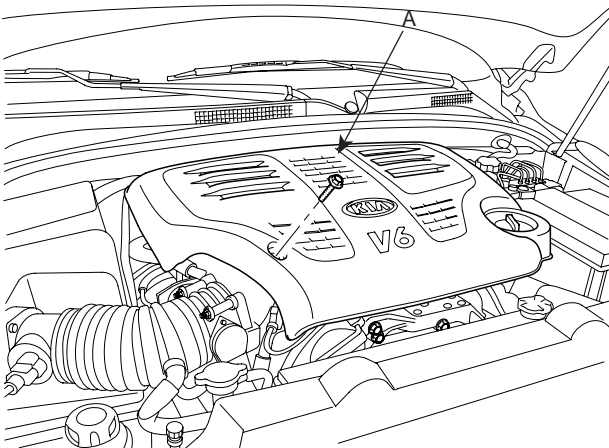

SBLAT6004L

3. Remove the O2 sensor connectors(A).

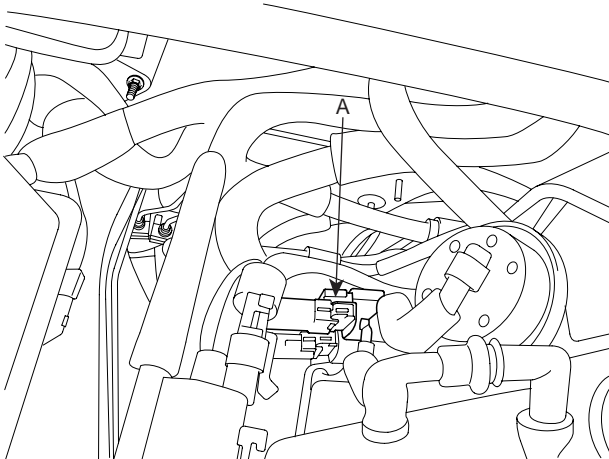

SBLAT6005L

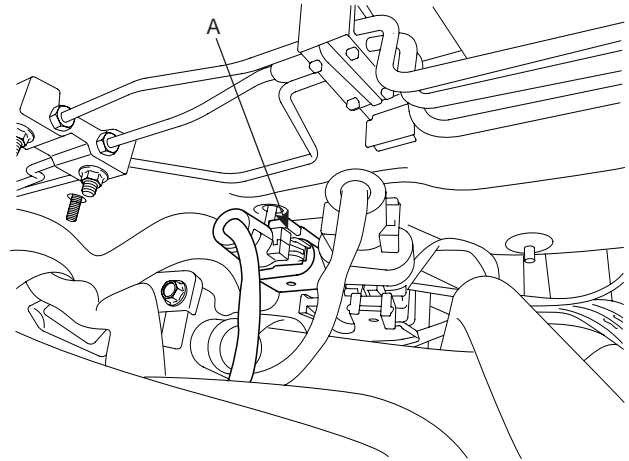

SBLAT6006L

4. Remove the under cover(A).

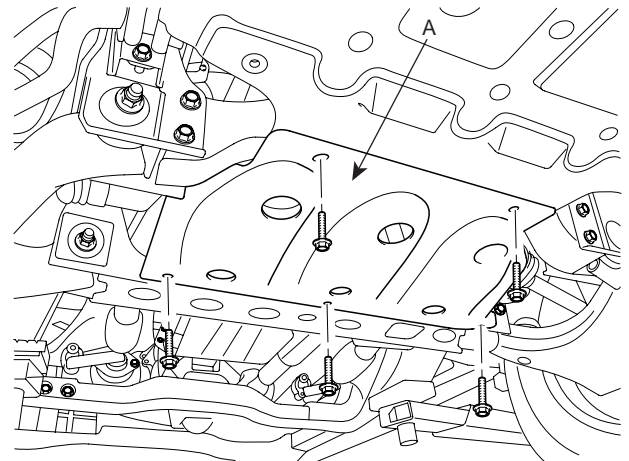

SBLAT6002L

5. Drain the automatic transmission fluid.

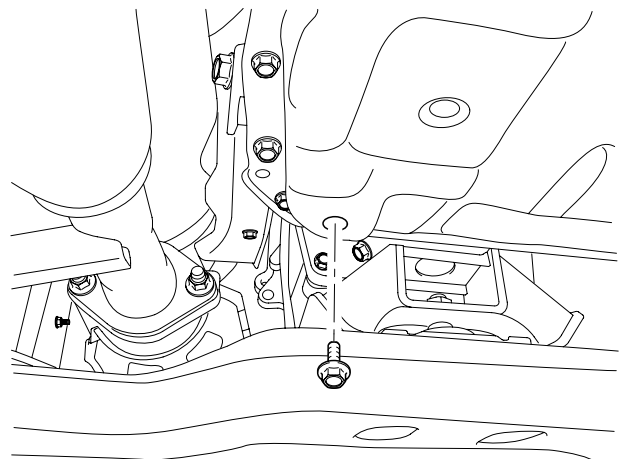

SBLAT6003L

6. Remove the front propeller shaft(A). (4WD)

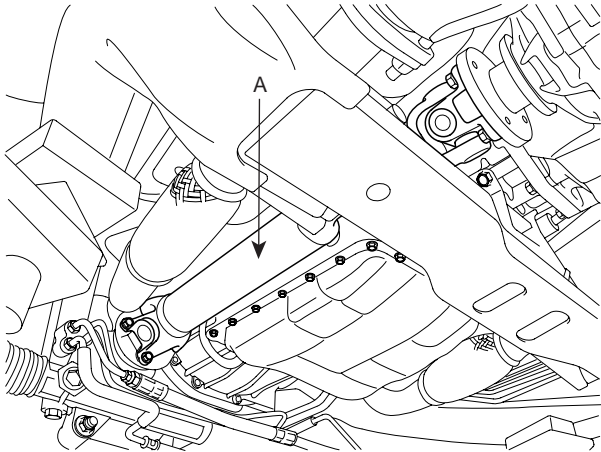

SBLAT6007L

9. Remove the transmission oil level gauge(A).

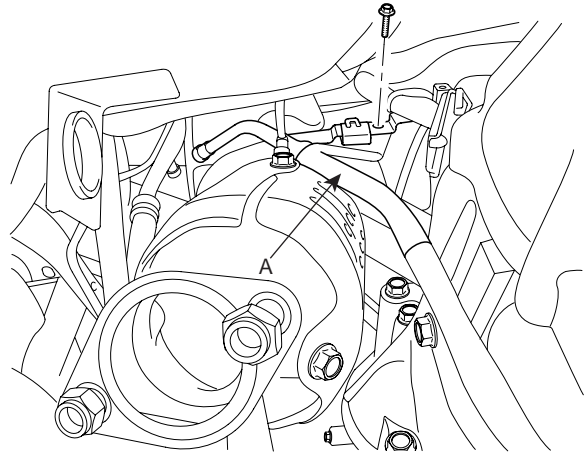

SBLAT6013L

7. Remove the front muffler(A) and the heat protector.

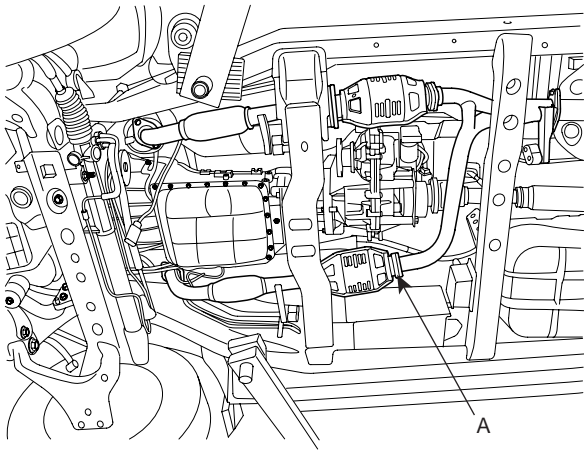

SBLAT6008L

10. Remove the shift cable cover(A).

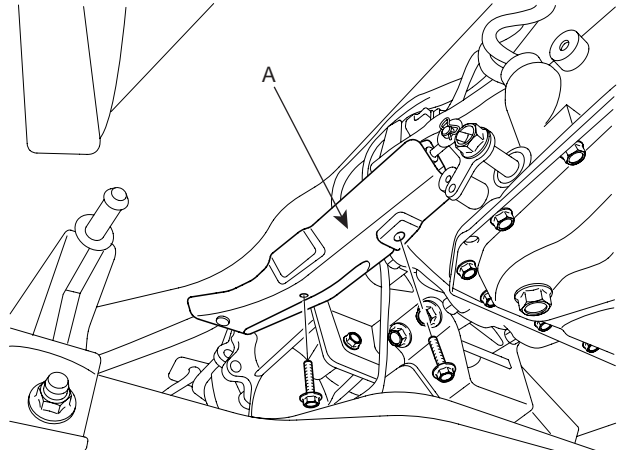

SBLAT6010L

8. Remove the rear propeller shaft(A).

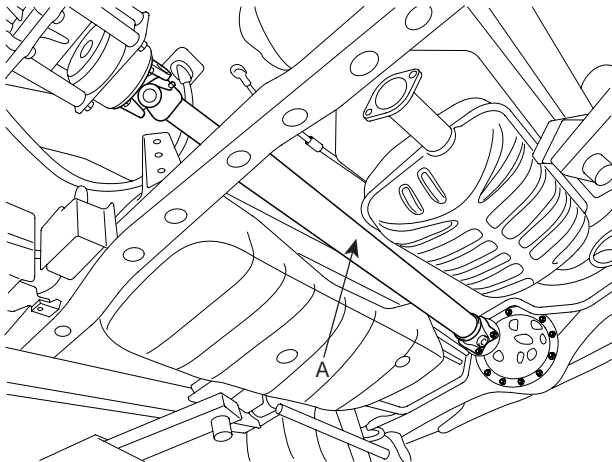

SBLAT6009L

11. Remove the shift cable(A).

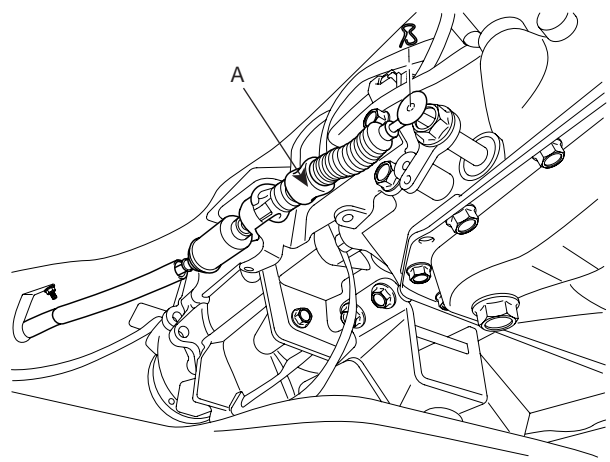

SBLAT6011L

12. Remove the oil cooler pipes(A).

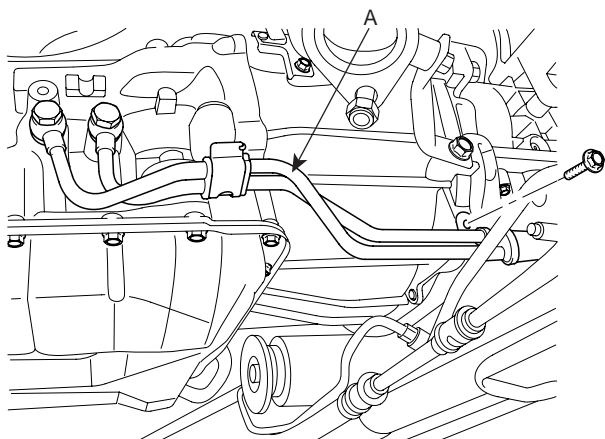

SBLAT6012L

15. Remove the transmission lower mounting bolts(A).

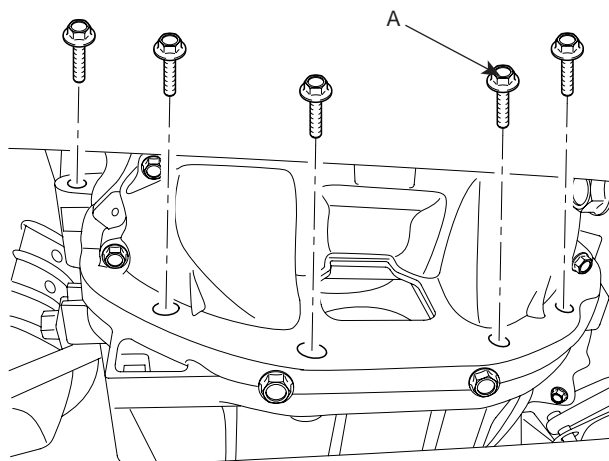

SBLAT6016L

13. Remove the drive plate cover(A).

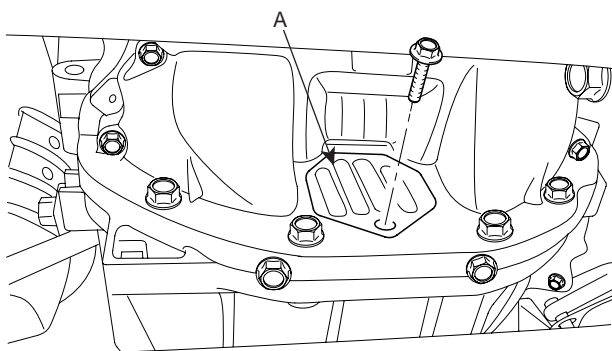

SBLAT6014L

16. Remove the starter motor mounting bolts(A) and the other bolts(B).

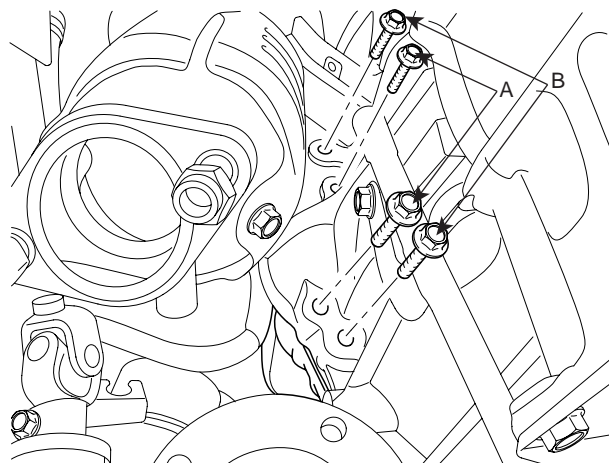

SBLAT6017L

14. Remove the drive plate bolts (A)

NOTE

Remove the bolts(A-6ea) rotating the crankshaft clockwise.

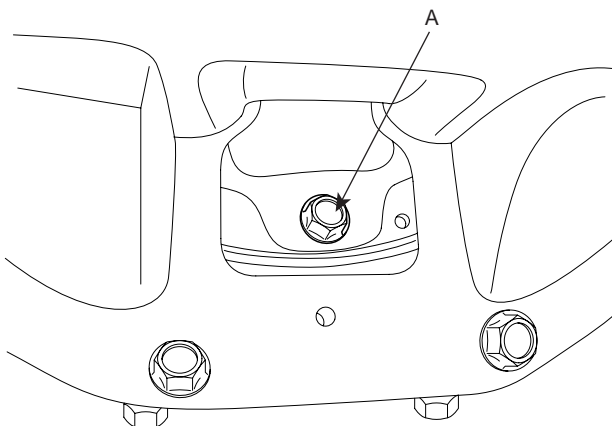

SBLAT6015L

17. Remove the mounting bolts(A) supporting the transmission with a jack.

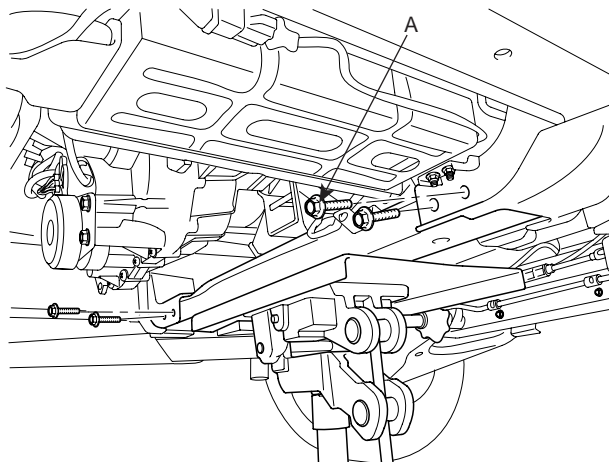

SBLAT6018L

AT -200

AUTOMATIC TRANSAXLE (A5SR1/2)

18. Lower the jack slightly to make easy to remove the related connector and bolts on the upper part of transmission.

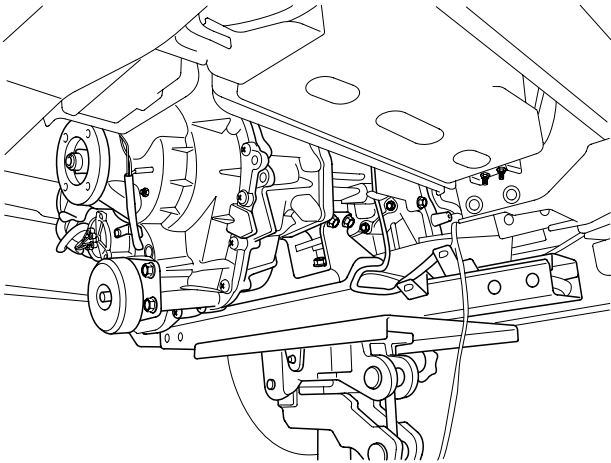

SBLAT6019L

19. Disconnect the transmission wire harness connectors.

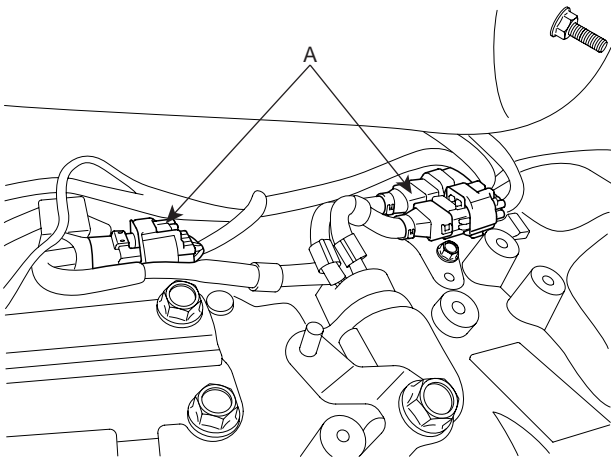

SBLAT6024L

20. Remove the vehicle speed sensor connector(A).

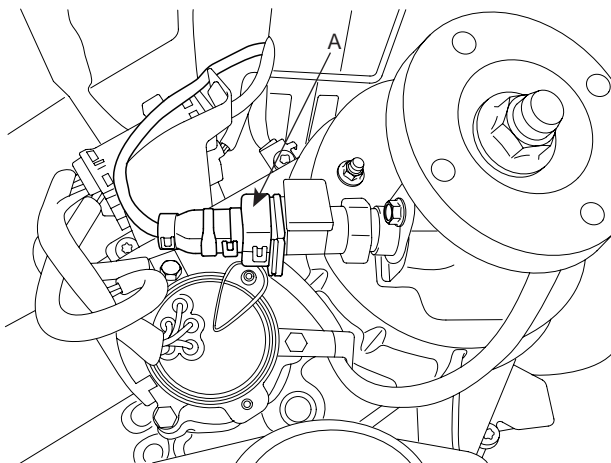

SBLAT6022L

21. Remove the transfer case connectors(A). (4WD)

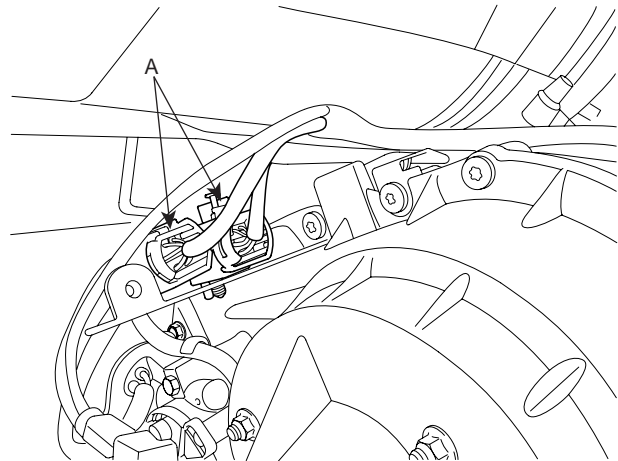

SBLAT6023L

22. Remove the transmission upper mounting bolt(A).

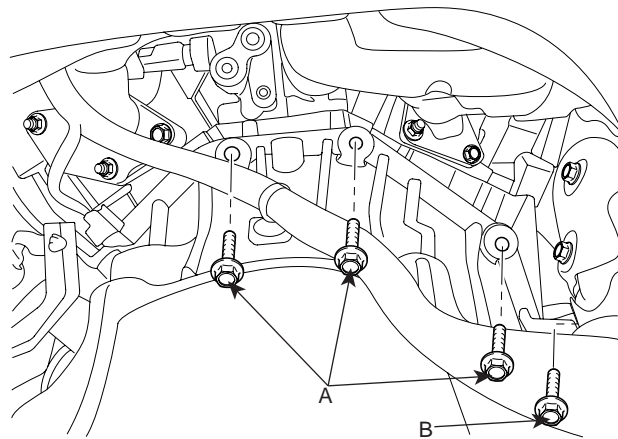

SBLAT6020L

23. Remove the transmission assembly(A).

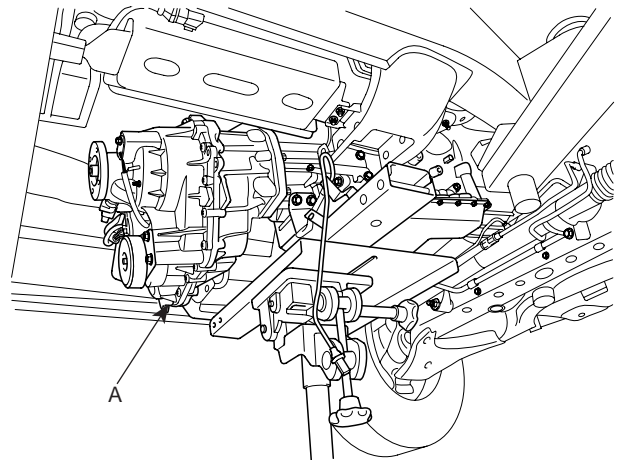

SBLAT6021L

INSTALLATION EFDF6CD2

1. Lowering the vehicle or lifting up a jack, install the transmission assembly(A/B).

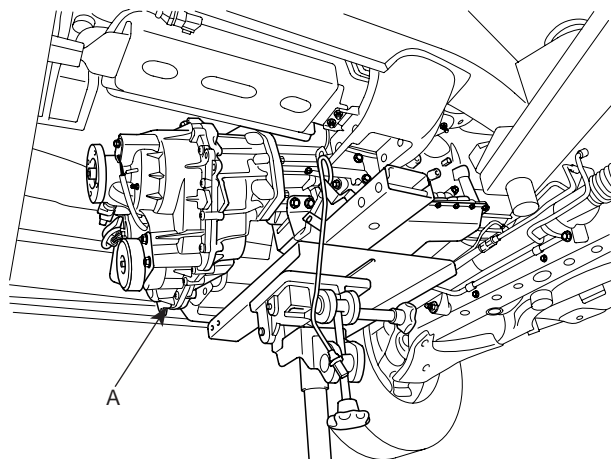

SBLAT6021L

2. Tighten the transmission mounting bolts(A).

TORQUE

A : 63.7~83.3Nm (6.5~8.5kgf.m, 47~61.4lb-ft)

B : 78.4~98Nm (8.0~10kgf.m, 57.8~72.3lb-ft)

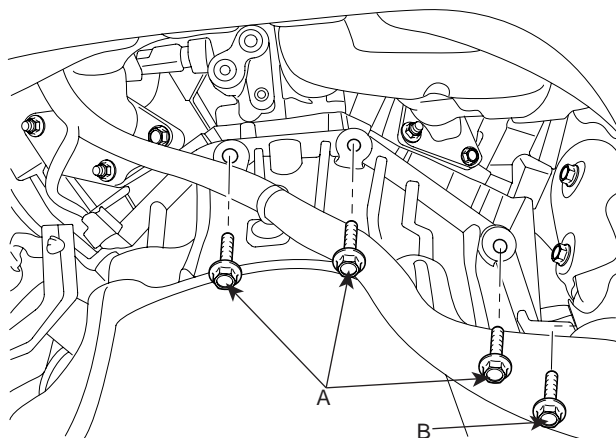

SBLAT6020L

3. Install the transfer case connectors(A). (4WD)

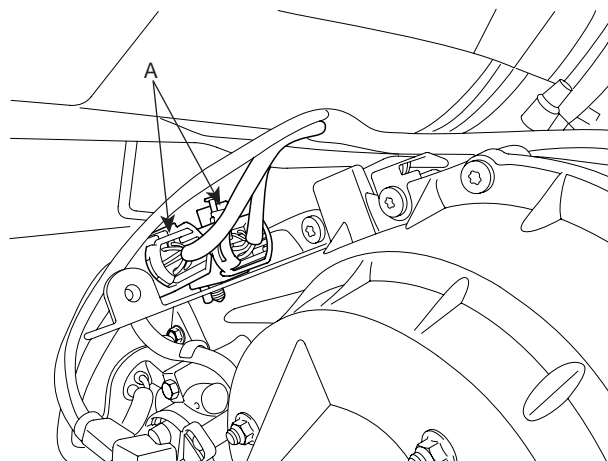

SBLAT6023L

4. Install the vehicle speed sensor connector(A).

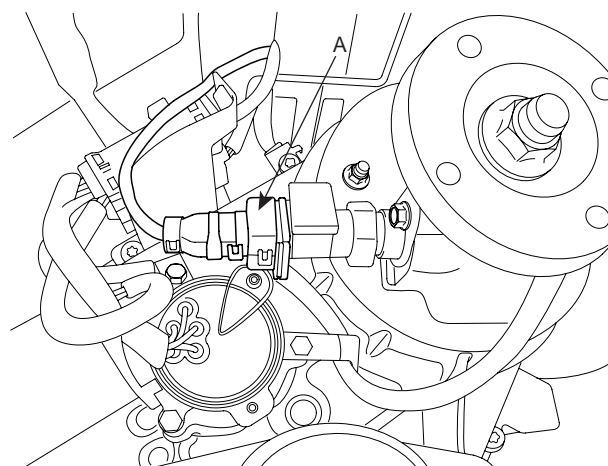

SBLAT6022L

5. Connect the transmission wire harness connectors(A).

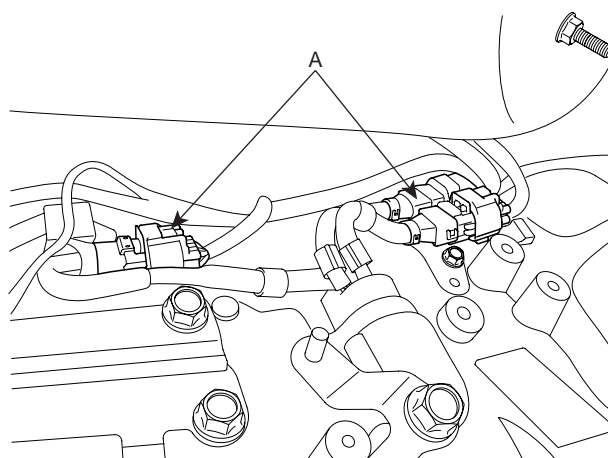

SBLAT6024L

AT -202

AUTOMATIC TRANSAXLE (A5SR1/2)

6. Install the crossmember mounting bolts(A).

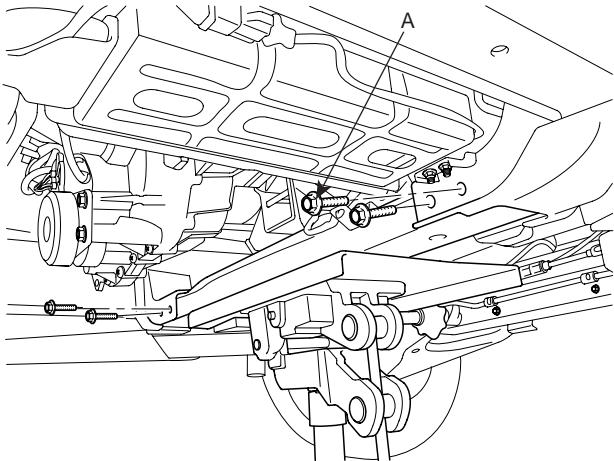

SBLAT6018L

7. Install the starter motor mounting bolts(A) and the other bolts(B).

TORQUE

A : 50~65Nm (5.0~6.5kgf.m, 36.2~47.0lb-ft)

B : 34.3~46Nm (3.5~4.7kgf.m, 25.3~33.9 lb-ft)

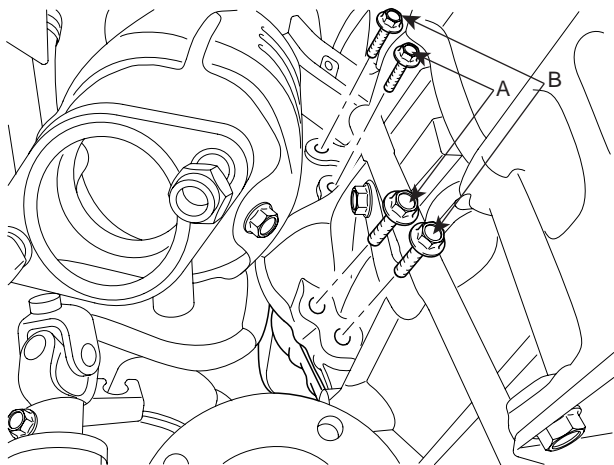

SBLAT6017L

8. Install the Tighten the transaxle lower mounting bolts(A).

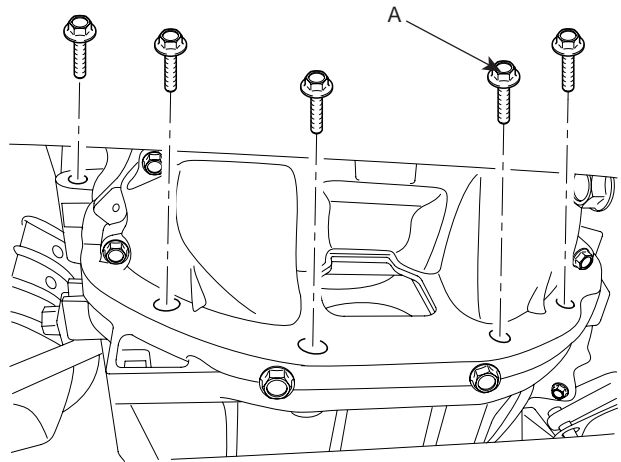

SBLAT6016L

9. Install the drive plate bolts (A) by turning the timing gear.

TORQUE :

34.3~41.1Nm (3.5~4.2kgf.m, 25.3~30.3lb-ft)

NOTE

Install the bolts(A-6ea) rotating the crankshaft clockwise.

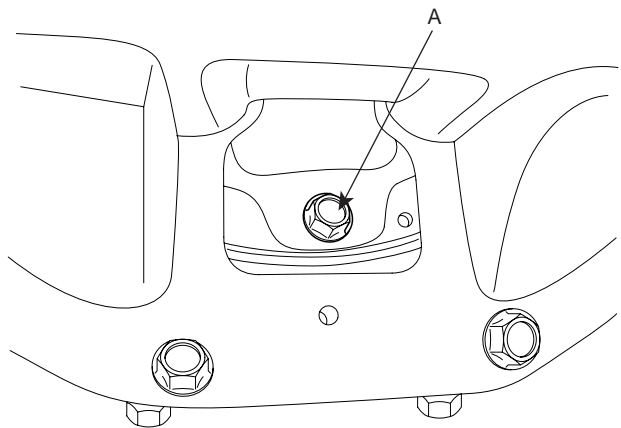

SBLAT6015L

10. Install the drive plate cover(A).

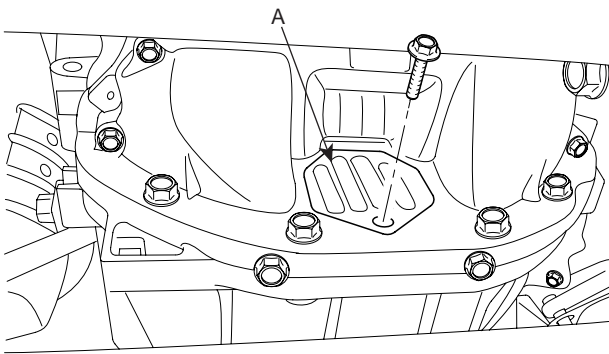

SBLAT6014L

13. Install the shift cable cover(A).

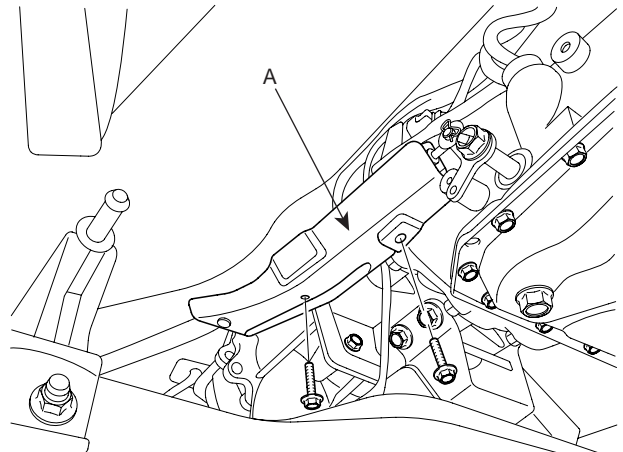

SBLAT6010L

11. Install the oil cooler pipes(A).

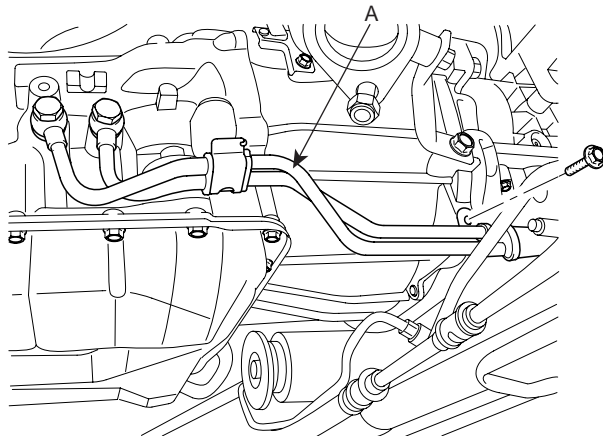

SBLAT6012L

14. Install the transmission oil level gauge(A).

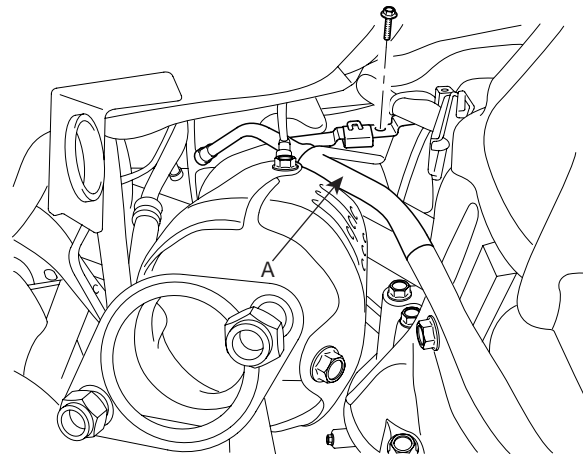

SBLAT6013L

12. Install the shift cable(A).

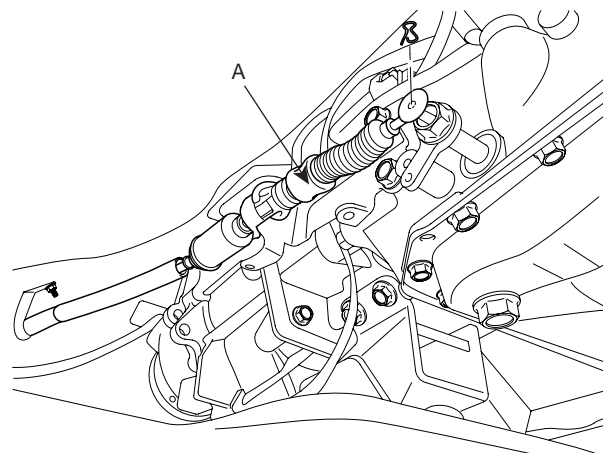

SBLAT6011L

15. Install the rear propeller shaft(A).

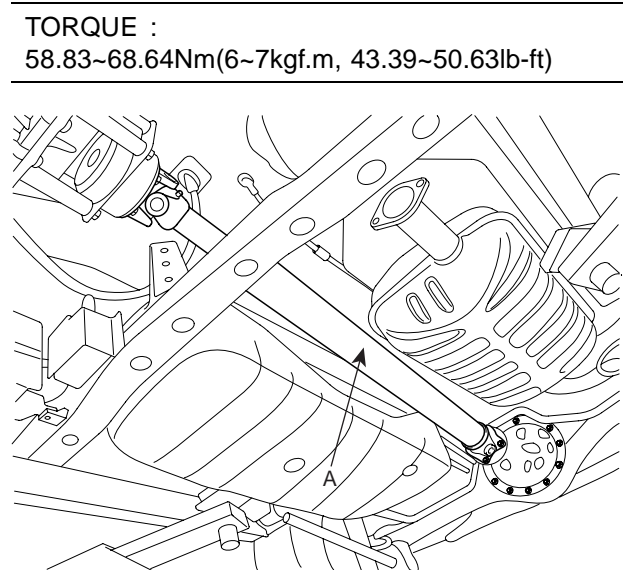

SBLAT6009L

TORQUE :
58.83~68.64Nm(6~7kgf.m, 43.39~50.63lb-ft)

AT -204

AUTOMATIC TRANSAXLE (A5SR1/2)

16. Install the front muffler(A) and the heat protector.

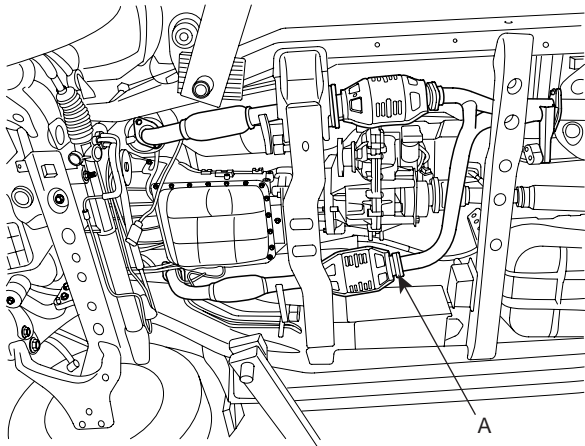

SBLAT6008L

19. Install the under cover(A).

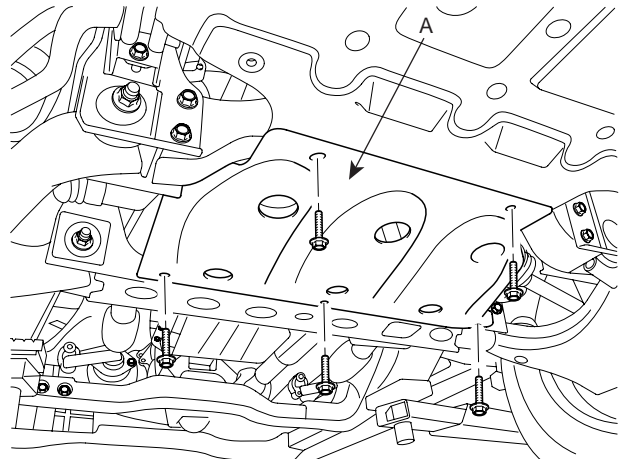

SBLAT6002L

17. Install the front propeller shaft(A). (4WD)

TORQUE :
58.83~68.64Nm(6~7kgf.m, 43.39~50.63lb-ft)

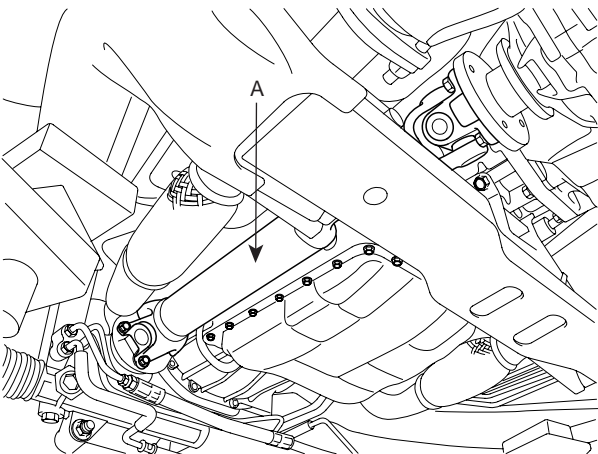

SBLAT6007L

18. Refill the transmission fluid. (see 'Service adjustment procedure')

20. Install the O2 sensor connectors(A).

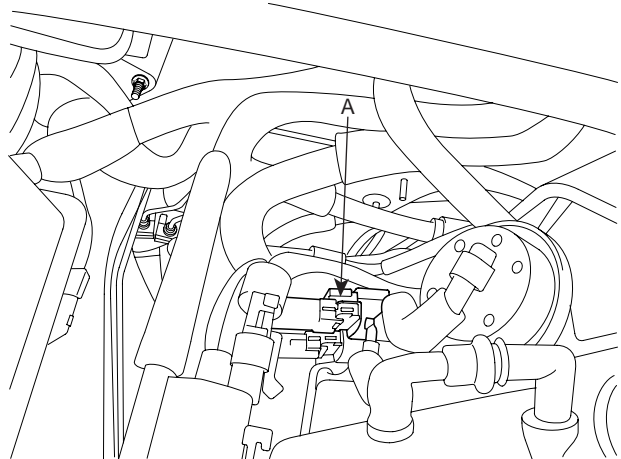

SBLAT6005L

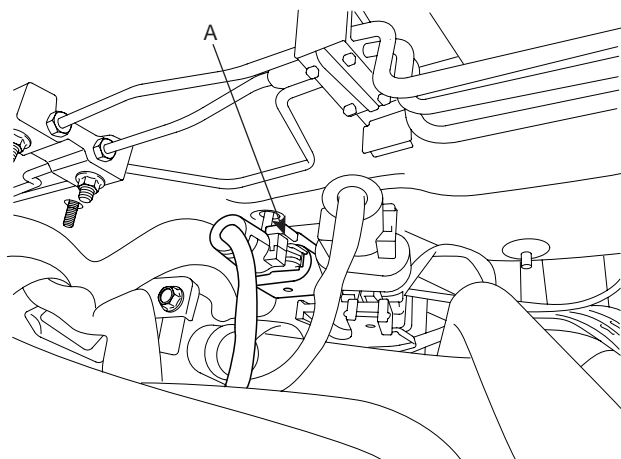

SBLAT6006L

21. Install the engine cover(A).

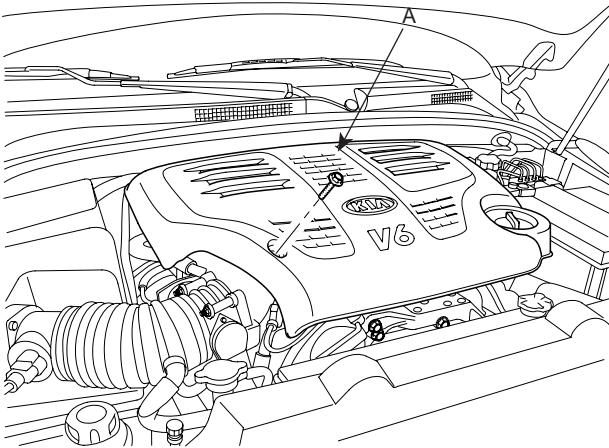

SBLAT6004L

22. Install the battery (-) terminal(A).

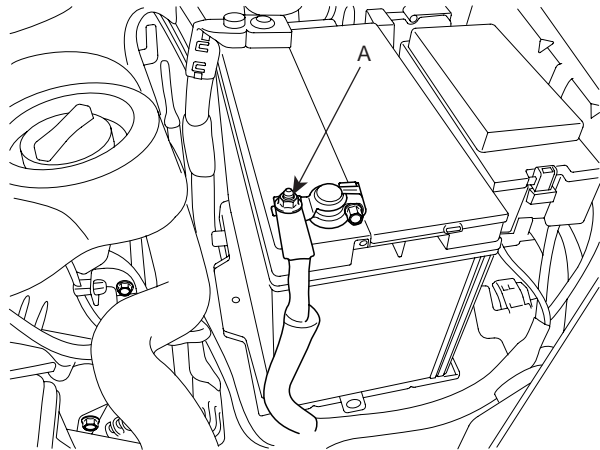

SBLAT6001L

23. Refill the transmission fluid. (See 'service adjustment procedure')