

Automatic Transaxle (A5HF1)

GENERAL

SPECIFICATIONS.....	ATA-2
SERVICE STANDARD.....	ATA-2
TIGHTENING TORQUE.....	ATA-3
SEALANTS.....	ATA-3
SPECIAL TOOLS.....	ATA-4

AUTOMATIC TRANSAXLE

COMPONENTS.....	ATA-146
REMOVAL.....	ATA-148
INSTALLATION.....	ATA-152

AUTOMATIC TRANSAXLE SYSTEM

INSPECTION CHART FOR DIAGNOSTIC

TROUBLE CODES(DTC).....	ATA-6
P0707.....	ATA-10
P0708.....	ATA-16
P0711.....	ATA-19
P0712.....	ATA-24
P0713.....	ATA-27
P0717.....	ATA-29
P0722.....	ATA-37
P0731.....	ATA-43
P0732.....	ATA-51
P0733.....	ATA-59
P0734.....	ATA-67
P0735.....	ATA-74
P0736.....	ATA-81
P0741.....	ATA-89
P0742.....	ATA-93
P0743.....	ATA-94
P0746.....	ATA-100
P0748.....	ATA-106
P0750.....	ATA-108
P0755.....	ATA-114
P0760.....	ATA-120
P0765.....	ATA-126
P0770.....	ATA-131
P0885.....	ATA-136
P0890.....	ATA-139
P0891.....	ATA-144

GENERAL

SPECIFICATION EC8A7AA4

Automatic transaxle type		A5HF1
Recommended transaxle oil		Diamond ATF SP III or SK ATF SP III
Oil quantity		10.9 Liter (Only for the reference)
Oil inspection and supplement		Every one year or every 24,000 km
Replacement	Private use (Normal use)	No service required
	Private use (Severe use)	Every 48,000 Km in severe use(1~4)
	Business use	<ol style="list-style-type: none"> 1. Driving on rough road(bumpy road, gravel road, snowy road, unpaved road etc.) 2. Driving on mountain road, ascent/descent 3. Repetition of short distance driving 4. More than 50% operation in heavy city traffic during hot weather above 32°C 5. Police, Taxi. Commercial type operation
Engine type		3.3 DOHC
Gear ratio	1st	3.789
	2nd	2.064
	3rd	1.421
	4th	1.034
	5th	0.728
	Reverse	3.808
	Final reduction gear ratio	3.333

SERVICE STANDARD

ITEM	VALUE (mm/inch)
Input shaft end play	0.7-1.45 / 0.0276-0.0571
Low & Reverse brake pressure plate end play	1.65-2.11 / 0.0650-0.0831
Reaction plate snap end play	0-0.16 / 0-0.0063
2ND brake pressure plate end play	1.09-1.55 / 0.0429-0.0610
Underdrive sun gear end play	0.25-0.45 / 0.0098-0.0177
Differential bearing spacer end play	0.045-0.105 / 0.0018-0.0041
Underdrive clutch snap ring end play	1.6-1.8 / 0.0630-0.0709
Direct clutch reaction plate snap ring end play	0.6-0.8 / 0.0236-0.0315
Reverse clutch snap ring end play	0-0.09 / 0-0.0035
Overdrive clutch snap ring end play	1.0-1.2 / 0.0394-0.0472
Reverse clutch reaction plate snap ring end play	1.5-1.7 / 0.0591-0.0669

TIGHTENING TORQUE



ITEM	Nm	Kgf.cm	lb-ft
Transfer drive gear	31.4-36.3	320.0-370.0	23.1-26.8
Rear cover	19.6-25.5	200.0-260.0	14.5-18.8
Anchor plug	83.4-112.8	850.0-1150.0	61.5-83.2
Oil pump pipe	9.8-11.8	100.0-120.0	7.2-8.7
Oil pump	19.6-25.5	200.0-260.0	14.5-18.8
Torque converter housing	42.0-54.0	428.0-551.0	31.0-39.9
Valve body	9.8-11.8	100.0-120.0	7.2-8.7
VFS reservoir	9.8-11.8	100.0-120.0	7.2-8.7
Detent spring	4.9-6.9	50.0-70.0	3.6-5.1
Valve body cover	9.8-11.8	100.0-120.0	7.2-8.7
Vehicle speed sensor	3.9-5.9	40.0-60.0	2.9-4.3
Inhibiter switch	9.8-11.8	100.0-120.0	7.2-8.7
Manual control lever	17.7-24.5	180.0-250.0	13.0-18.1
Input/Output speed sensors	9.8-11.8	100.0-120.0	7.2-8.7
Reduction brake piston rod fixing nut	14.7-24.5	150.0-250.0	10.8-18.1
Sub frame bracket	88.3-107.9	900.0-1100.0	65.1-79.6
Valve body inside seperating plate	4.9-6.9	50.0-70.0	3.6-5.1
Valve body cover seperating plate	9.8-11.8	100.0-120.0	7.2-8.7
Direct planetary carrier lock nut	156.9-176.5	1600.0-1800.0	115.7-130.2

SEALANTS

Rear cover liquid gasket	Specified sealant
Rear cover liquid gasket	Threbond 1281B or LOCTITE FMD-546
Torque converter housing liquid gasket	
Valve body liquid gasket	

SPECIAL TOOLS E97C0A27

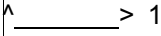
Tool (Number and name)	Illustration	Use
09453-3A110 Spring compressor	KKCF100A	- Removal and installation of one way clutch inner race snap ring
09431-39000 Oil seal installer	KKCF100B	- Installation of differential bearing output race
09456-39100 Clearance dummy plate	KKCF100C	- Installation of brake pressure plate
09454-3A110 Reduction socket	KKCF100D	- Adjustment of reduction brake piston rod
09452-21200 Oil pump oil seal installer	KKCF100E	- Installation of oil seal in a oil pump

Tool (Number and name)	Illustration		Use
09453-24000 Snap ring compressor	 <p style="text-align: right;">KKCF100F</p>		<ul style="list-style-type: none"> - Removal and installation of under drive clutch snap ring
09453-4C400 Spring compressor	 <p style="text-align: right;">KKCF100G</p>		<ul style="list-style-type: none"> - Removal and installation of direct clutch snap ring - Removal and installation of reverse & over drive clutch spring retainer snap ring
09215-3C000 Oil fan remover	<p style="text-align: right;">KKCF100H</p>		<ul style="list-style-type: none"> - Removal of valve body cover
09455-21100 Bearing installer	<p style="text-align: right;">KKCF100I</p>		<ul style="list-style-type: none"> - Installation of the ball bearing and the transfer drive gear
09457-22000 Removing plate	<p style="text-align: right;">KKCF100J</p>		<ul style="list-style-type: none"> - Removal of the differential bearing, the transfer shaft bearing and drive gear bearing.

AUTOMATIC TRANSAXLE SYSTEM

INSPECTION CHART FOR DIAGNOSIS

TROUBLE CODES (DTC) E880B496

No.	Code	Item	MIL	Remark
1	P0707	Transaxle range switch circuit - LOW input	ON	ATa-10
2	P0708	Transaxle range switch circuit - HIGH input	ON	ATa-16
3	P0711	Transaxle Fluid Temperature Sensor Rationality	ON	ATa-19
4	P0712	Fluid(Oil) Temperature Sensor Circuit - Low	ON	ATa-24
5	P0713	Fluid(Oil) Temperature Sensor Circuit - High	ON	ATa-27
6	P0717	Input Speed Sensor Circuit - No Signal	ON	ATa-29
7	P0722	Output Speed Sensor Circuit - No Signal	ON	ATa-37
8	P0731	Gear 1 Incorrect Ratio	ON	ATa-43
9	P0732	Gear 2 Incorrect Ratio	ON	ATa-51
10	P0733	Gear 3 Incorrect Ratio	ON	ATa-59
11	P0734	Gear 4 Incorrect Ratio	ON	ATa-67
12	P0735	Gear 5 Incorrect Ratio	ON	ATa-74
13	P0736	Reverse Gear Incorrect Ratio	ON	ATa-81
14	P0741	Torque Converter Clutch Circuit - Stuck off	ON	ATa-89
15	P0742	Torque Converter Clutch Circuit - Stuck on	ON	ATa-93
16	P0743	Torque Converter Clutch Circuit - Electrical	ON	ATa-94
17	P0746	Pressure Control Solenoid Valve A - Performance or Stuck Off	OFF	ATa-100
18	P0748	Pressure Control Solenoid Valve A - Electrical	OFF	ATa-106
19	P0750	Shift Control Solenoid Valve A Circuit Malfunction (LR)	ON	ATa-108
20	P0755	Shift Control Solenoid Valve B Circuit Malfunction (UD)	ON	ATa-114
21	P0760	Shift Control Solenoid Valve C Circuit Malfunction (2ND)	ON	ATa-120
22	P0765	Shift Control Solenoid Valve D Circuit Malfunction (OD)	ON	ATa-126
23	P0770	Shift Control Solenoid Valve E Circuit Malfunction (RED)	ON	ATa-131
24	P0885	A/T Relay Circuit Malfunction	ON	ATa-136
25	P0890	AT Relay - Low Circuit	ON	ATa-139
26	P0891	AT Relay - open Circuit	ON	ATa-144

INPUT/OUTPUT SIGNAL VOLTAGE CHECK SHEET

C208-A

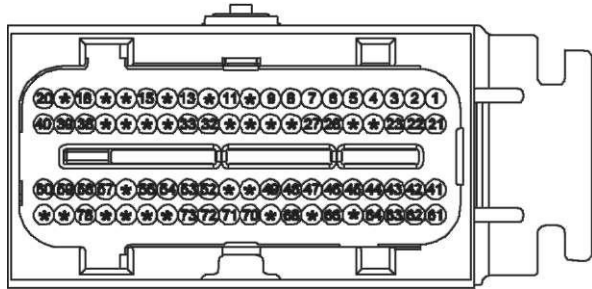

C208-B

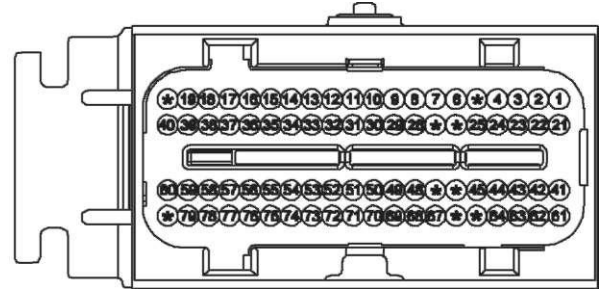

KKCF022A

PIN No.	Check item	Condition	Input/Output value		Remarks
			Type	Level	
A01	2nd CAN_HI	-	-	-	-
A02	2nd CANJ.O	-	-	-	-
A03	P Range Selection	P Position Otherwise	DC Voltage	V BAT Max. 1.0V	
A04	R Range Selection	R Position Otherwise	DC Voltage	V BAT Max. 1.0V	
A05	N Range Selection	N Position Otherwise	DC Voltage	V BAT Max. 1.0V	
A06	D Range Selection	D Position Otherwise	DC Voltage	V BAT Max. 1.0V	
A07	Select Position	-	DC Voltage	V BAT Max. 1.0V	
A08	Up Position	-	DC Voltage	V BAT Max. 1.0V	
A09	Down Position	-	DC Voltage	V BAT Max. 1.0V	
A12	N.A	-	-	-	
A14	N.A	-	-	-	
A19	N.A	-	-	-	
A20	A/T Control Relay	Relay On Relay Off	DC Voltage	V BAT Max. 1.0V Vpeak : Max. 70V Resistance : 680 Ohm	
		W/H Open		DTC Spec : P0890	
A27	Diagnosis "K"	Communicated with GST	Pulse	At transmitting HI : V BAT* 80% t LO : VBAT * 20% l AT receiving HI : V BAT* 70% t LO : V_BAT*30% i	V BAT : 13.2V
A31	N.A	-	-	-	

PIN No.	Check item	Condition	Input/Output value		Remarks
			Type	Level	
A32	A/C Pressure Analog	-	-	-	-
A34	N.A	-	-	-	
A36	N.A	-	-	-	
A37	N.A	-	-	-	
A41	CANJHI	Recessive Dominant	Pulse	2.0 - 3.0 V 2.75 - 4.5 V	
A42	CAN_LO	Recessive Dominant	Pulse	2.0 - 3.0 V 0.5 - 2.25 V	
A60	A/T PWR Source	IG Off IG On	DC Voltage	Max. 0.5 V VBAT	
		IG. Key On IG. Key Off Idle Key Off from Idle Fuse 1/2/3 Removal Condition W/H Open		MAX. +/- 75V (ECU GND) MAX. +/- 75V (ECU GND) MAX. +/- 75V (ECU GND) MAX. +/- 75V (ECU GND) MAX. +/- 75V (ECU GND)	
A73	Shift Position Signal(To Cluster)	Running	Pulse	HI : V BAT LO : Max. 1.0V Freq.: 50±2Hz (Reference)	Sports mode
		1 gear	Duty	12.5±2%	
		2 gear	T	27.5±2%	
		3 gear	t	42.5±2%	
		4 gear	t	57.5±2%	
5 gear	T	72.5±2%			
B03	UD Solenoid	Shifting	Pulse	HI : V BAT LO : Max. 1.0V Vpeak : Max. 70V	
		W/H Open		DTC Spec : P0755	
B05	N.A	-	-	-	
B06	Oil temperature sensor ATM	Idle	Analog	0.5V - 4.5V	16Hz
B09	Output speed sensor	30kph	Pulse	HI : Min. 4.0V LO : Max. 1.0V	
		W/H Open		DTC Spec : P0722	
B10	Input speed sensor	Idle	Pulse	HI : Min. 4.0V LO : Max. 1.0V	630Hz
		W/H Open		DTC Spec : P0717	
B20	N.A	-	-	-	
B22	LR Solenoid	Shifting	Pulse	HI : V BAT LO : Max. 1.0V Vpeak : Max. 70V	
		W/H Open		DTC Spec : P0750	
B26	N.A	-	-	-	

PIN No.	Check item	Condition	Input/Output value		Remarks
			Type	Level	
B27	N.A	-	-	-	
B33	GND_Sensor	Idle	DC Voltage	Max. 50 mV	WTS & OTS_ATM
		W/H Open		DTC Spec : P0118/1115	
B42	OD Solenoid	Shifting	Pulse	HI : V BAT LO : Max. 1.0V Vpeak : Max. 70V	
		W/H Open		DTC Spec : P0765	
B43	DCC solenoid	LockUp on	Pulse	HI : V BAT LO : Max. 1.0V Vpeak : Max. 70V	
		W/H Open		DTC Spec : P0743	
B44	RED Solenoid	Shifting	Pulse	HI : V BAT LO : Max. 1.0V Vpeak : Max. 70V	
		W/H Open		DTC Spec : P0770	
B45	2ND Solenoid	Shifting	Pulse	HI : V BAT LO : Max. 1.0V Vpeak : Max. 70V	
		W/H Open		DTC Spec : P0760	
B46	N.A	-	-	-	
B47	N.A	-	-	-	
B59	Variable Solenoid (-)	Idle	Pulse	HI : V BAT LO : Max. 1.0V Vpeak : Max. 70V	600Hz
		W/H Open		DTC Spec : P0748	
B65	N.A	-	-	-	
B66	N.A	-	-	-	
B75	Variable Solenoid (+)	Idle	Pulse	HI : V BAT LO : Max. 1.0V Vpeak : Max. 70V	
		W/H Open		DTC Spec : P0748	
B80	N.A	-	-	-	

DTC P0707 TRANSAXLE RANGE SWITCH - LOW INPUT

COMPONENT LOCATION EE12AB70

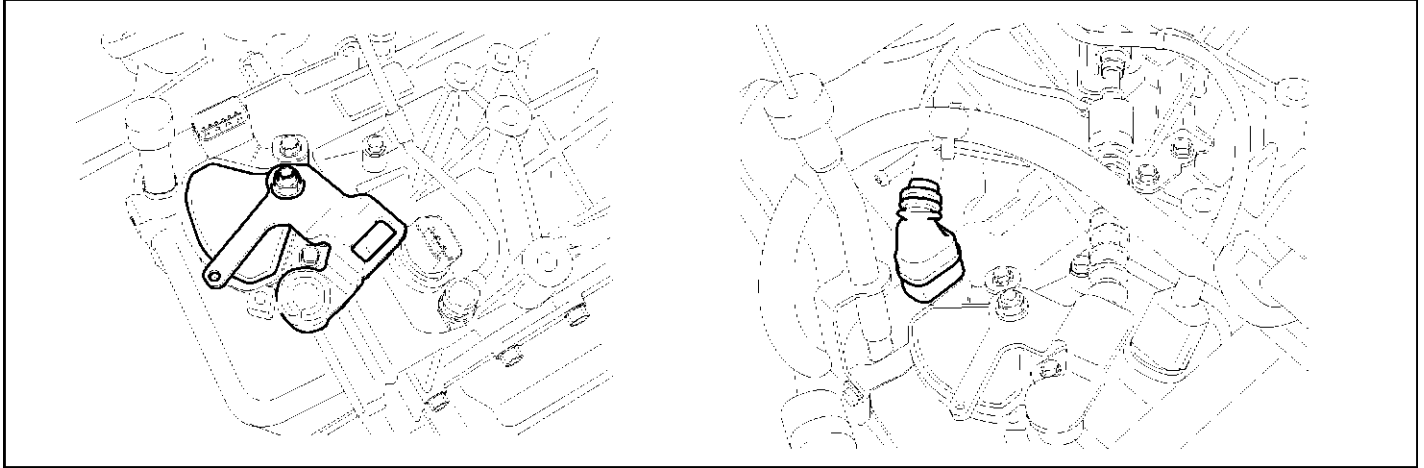

KKCF200A

GENERAL DESCRIPTION E, E1, 66

Transaxle range switch sends information of the shift lever position to the PCM by using 12V(the battery voltage). By detecting the position of the transaxle range, to start the engine is possible only when the gear position is in the parking or neutral position and the back up lamp is on only in reverse position.

DTC DESCRIPTION E5C88206

The PCM sets this code when the transaxle range switch has no output signal for more than 30 seconds.

DTC DETECTING CONDITION E3A3B668

Item	Detecting Condition & Fail Safe	Possible cause
DTC Strategy	<ul style="list-style-type: none"> • Check for no signal 	<ul style="list-style-type: none"> • Open or short in circuit • Faulty TRANSAXLE RANGE SWITCH • Faulty PCM
Enable Conditions	<ul style="list-style-type: none"> • Engine state=Run • PRNDL Diag disabling fault present flag=FALSE • Battery Voltage > 11V and < 16 V • Throttle position^ 3% 	
Threshold value	<ul style="list-style-type: none"> • No signal detected 	
Diagnostic Time	<ul style="list-style-type: none"> • More than 30sec 	
Fail Safe	<ul style="list-style-type: none"> • If there are no or multiple signals from the transaxle range switch, the PCM will continue to control with the signal which is detected just before DTC occurs. 	

SPECIFICATION E3AF2FE4

Inspection condition	Reference value	
* IG KEY : ON or Engine stall	Shift lever : P	P,N
	Shift lever : R	R
	Shift lever : N	P,N
	Shift lever : D	D

MONITOR SCANTOOL DATA EA558662

1. Connect scantool to data link connector(DLC).
2. Ignition "ON" & Engine "OFF".
3. Monitor the "TRANSAXLE RANGE SWITCH" parameter on the scantool.
4. Move selector lever from "P" range to other range.

1. 2 CURRENT DATA	
-	*TBANSAHLE RANGE SU
P, N	$\sim\sim P^{\wedge} N \setminus / N^{\prime} _ p^*$ R R
NOT FIXED	
FIX	Z(-) Z(+)

ELQE006A

5. Does "TRANSAXLE RANGE SWITCH" follow the reference data?

YES

- Fault is intermittent caused by poor contact in the sensor's and/or PCM's connector or was repaired and PCM memory was not cleared. Thoroughly check connectors for looseness, poor connection, bending, corrosion, contamination, deterioration or damage. Repair or replace as necessary and go to "Verification vehicle repair" procedure.

NO

- Go to "Terminal & connector inspection" procedure.

ATA-12

TERMINAL & CONNECTOR INSPECTION EA47,,CE

1. Many malfunctions in the electrical system are caused by poor harness and terminals. Faults can also be caused by interference from other electrical systems, and mechanical or chemical damage.
2. Thoroughly check connectors for looseness, poor connection, bending, corrosion, contamination, deterioration, or damage.
3. Has a problem been found?

YES

- Repair as necessary and go to "Verification vehicle Repair" procedure.

NO

- Go to "Power supply circuit inspection" procedure.

POWER SUPPLY CIRCUIT INSPECTION ECFO,,A3

1. CHECK POWER TO RANGE SWITCH
 - 1) Disconnect "TRANSAXLE RANGE SWITCH" connector.
 - 2) Ignition "ON" & Engine "OFF".
 - 3) Measure voltage between terminal "8" of the sensor harness connector and chassis ground.

Specification : approx. B+

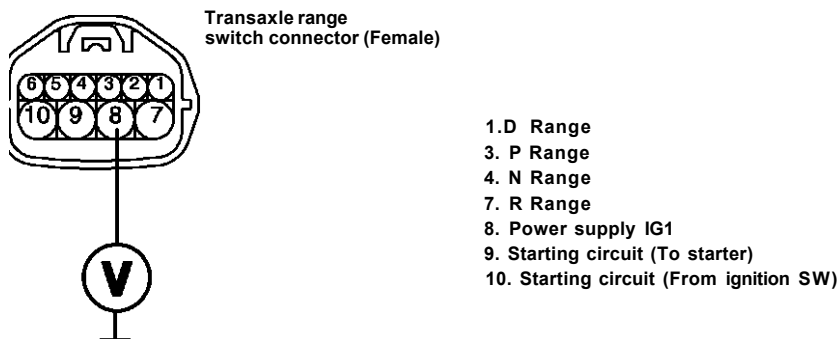

EKRF700B

- 4) Is voltage within specifications?

- Go to "Signal circuit inspection" procedure.

NO

- Check that Fuse 10A is installed or not blown.
- Check for open in harness. Repair as necessary and go to "Verification vehicle repair" procedure.

SIGNAL CIRCUIT INSPECTION E9AC18AF

1. Ignition "OFF".
2. Disconnect "TRANSAXLE RANGE SWITCH" and "PCM" connector.
3. Measure resistance between each terminal of the sensor harness connector and PCM harness connector as below.

Specification : Shown below

Pin No of "TRANSAXLE RANGE SWITCH"	No.1	No.3	No.4	No.7
Pin No of "PCM" harness	A-No.6	A-No.3	A-No.5	A-No.4
Specification	0Ω		0Ω	

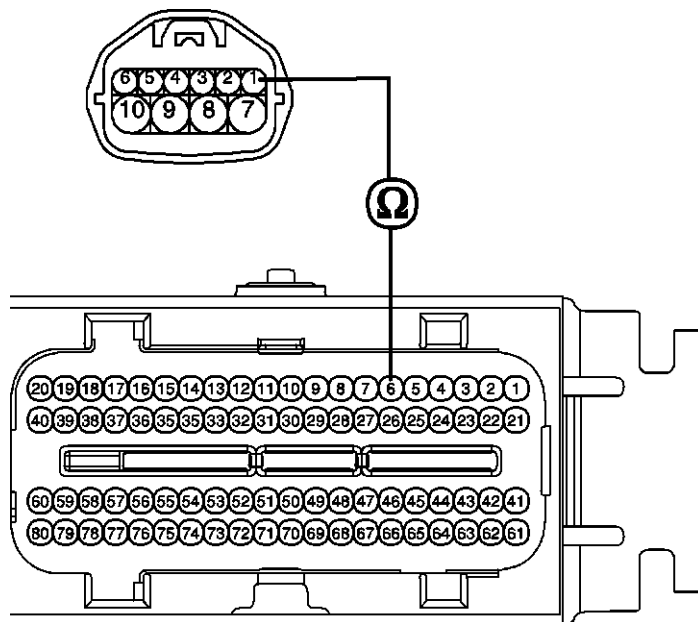

1. D Range
3. P Range
4. N Range
7. R Range
8. Power supply IG1
9. Starting circuit (To starter)
10. Starting circuit (From ignition SW)

3. P Range
4. R Range
5. N Range
6. D Range

EKRF700C

4. Is resistance within specifications?

YES

- Go to "Component inspection" procedure.

NO

- Check for open in harness. Repair as necessary and go to "Verification vehicle repair" procedure.

COMPONENT INSPECTION EOCBBAIF

1. Ignition "OFF".
2. Remove "TRANSAXLE RANGE SWITCH".
3. Measure the resistance between each terminal of the sensor.

Specification : approx. 0 Ω

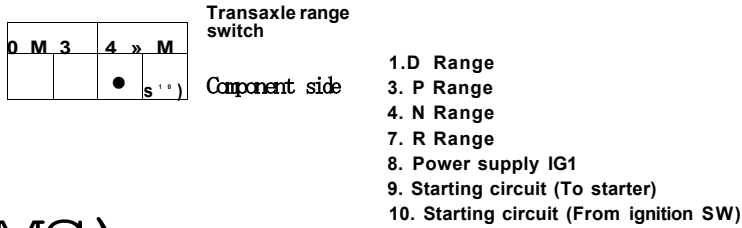

MS)

EKRF700D

Range	Terminal Number									
	1	2	3	4	5	6	7	8	9	10
P									○	○
R							○	○		
N				LJ				LJ	a	○
D										

[RANGE SWITCH continuity check table]

EKRF700E

4. Is resistance within specifications?

YES

- Substitute with a known-good PCM and check for proper operation. If the problem is corrected, replace PCM as necessary and then go to "Verification of vehicle repair" procedure.

NO

- Replace "TRANSAXLE RANGE SWITCH" as necessary and go to "Verification vehicle repair" procedure.

VERIFICATION OF VEHICLE REPAIR E,2BE,C7

After a repair, it is essential to verify that the fault has been corrected.

1. Connect scan tool and select "Diagnostic Trouble Codes(DTCs)" mode.
2. Using a scantool, Clear DTC.
3. Operate the vehicle within DTC Enable conditions in General information.
4. Are any DTCs present?

YES

- Go to the applicable troubleshooting procedure.

NO

- System performing to specification at this time.

DTC P0708 TRANSAXLE RANGE SWITCH - HIGH INPUT

COMPONENT LOCATION E8AB907F

Refer to DTC P0707.

GENERAL DESCRIPTION ED363FEF

Refer to DTC P0707.

DTC DESCRIPTION E732F0C2

The PCM sets this code when the transaxle range switch has two or more output signals for more than 30 seconds.

DTC DETECTING CONDITION E6EA259C

Item	Detecting Condition & Fail Safe	Possible cause
DTC Strategy	<ul style="list-style-type: none"> Check for No signal 	<ul style="list-style-type: none"> Open or short in TRANSAXLE RANGE SWITCH Faulty TRANSAXLE RANGE SWITCH Faulty PCM
Enable Conditions	<ul style="list-style-type: none"> Engine state=Run Battery Voltage > 11V and < 16V 	
Threshold value	<ul style="list-style-type: none"> Multiple signal 	
Diagnostic Time	<ul style="list-style-type: none"> More than 30sec 	
Fail Safe	<ul style="list-style-type: none"> If there are no or multiple signals from the transaxle range switch, the PCM will continue to control with the signal which is detected just before DTC occurs. 	

SPECIFICATION E0E4DC9F

Refer to DTC P0707.

MONITOR SCANTOOL DATA EDAD0F1A

Refer to DTC P0707.

TERMINAL & CONNECTOR INSPECTION E73AFBA

Refer to DTC P0707.

POWER SUPPLY CIRCUIT INSPECTION EAUISC

1. CHECK POWER TO RANGE SWITCH

- 1) Disconnect "TRANSAXLE RANGE SWITCH" connector.
- 2) Ignition "ON" & Engine "OFF".
- 3) Measure voltage between terminal "8" of the sensor harness connector and chassis ground.

Specification : approx. B+

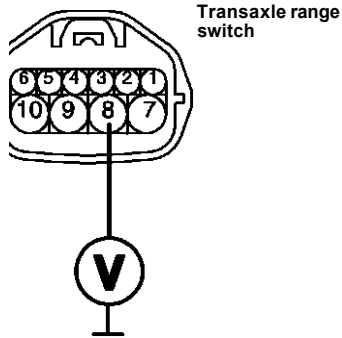

- 1. D Range
- 3. P Range
- 4. N Range
- 7. R Range
- 8. Power supply IG1
- 9. Starting circuit (To starter)
- 10. Starting circuit (From ignition SW)

4) Is voltage within specifications?

- Go to "Signal circuit inspection" procedure.
- Check for Short in harness. Repair as necessary and Go to "Verification Vehicle Repair" procedure.

SIGNAL CIRCUIT INSPECTION E4492542

1. Ignition "OFF".
2. Disconnect "TRANSAXLE RANGE SWITCH" and "PCM" connector.
3. Measure resistance between each terminals of the sensor harness to check for short.

Specification : Infinite

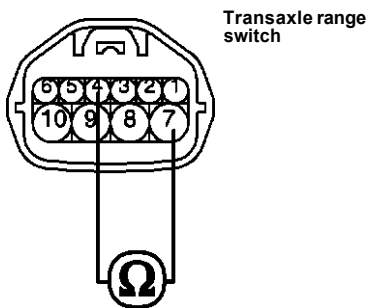

- 1. D Range
- 3. P Range
- 4. N Range
- 7. R Range
- 8. Power supply IG1
- 9. Starting circuit (To starter)
- 10. Starting circuit (From ignition SW)

4. Is resistance within specifications?

- Go to "Component inspection" procedure.
- Check for open in harness. Repair as necessary and Go to "Verification Vehicle Repair" procedure.

COMPONENT INSPECTION E6376DE6

Refer to DTC P0707.

VERIFICATION OF VEHICLE REPAIR EA...FD.

Refer to DTC P0707.

DTC P0711 TRANSAXLE FLUID TEMPERATURE SENSOR RATIONALITY

COMPONENT LOCATION E6BCABB5

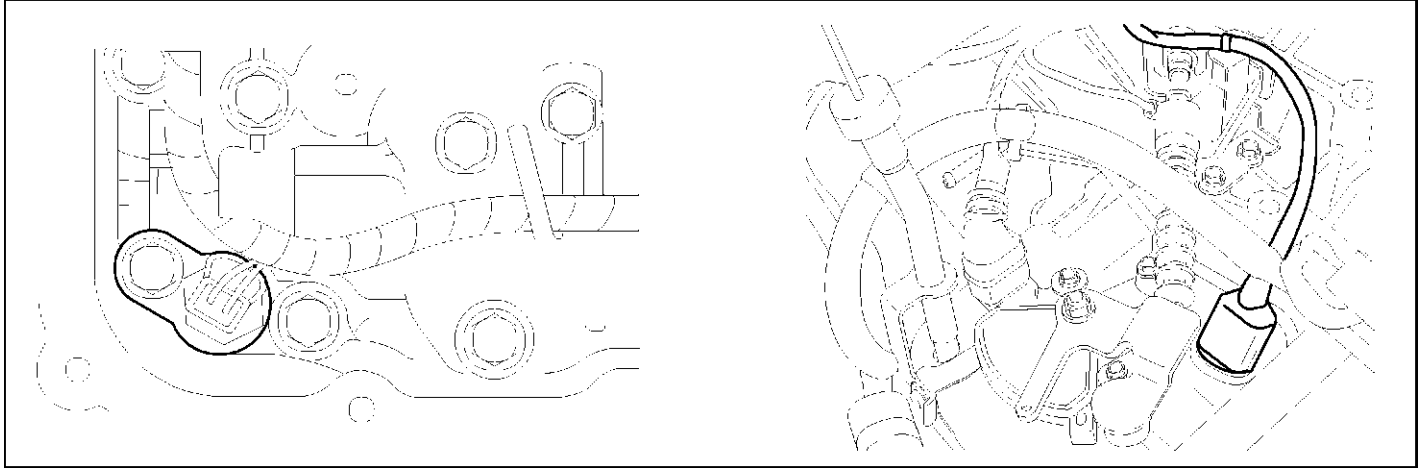

KKCF202A

GENERAL DESCRIPTION E30A2CBC

The oil temperature sensor is installed in the valve body and uses a thermistor that resistance changes by temperature change. PCM offers 5V as a reference voltage and the output voltage changes according to the ATF's temperature. The oil temperature sensor signal is important information in detecting torque converter clutch operation or non-operation area, the oil temperature sensor's variable controlling and oil pressure's controlling at shifting.

DTC DESCRIPTION EE7C5BD7

PCM displays this code if it detects the condition below for more than 1 second. PCM regards that the ATF's oil temperature is 85°C(185°F) since this code is sensed.

DTC DETECTING CONDITION E69EB1BF

Item	Detecting Condition & Fail Safe	Possible cause
DTC Strategy	<ul style="list-style-type: none"> • Check rationality 	<ul style="list-style-type: none"> • Sensor signal circuit is short to ground • Faulty sensor • Faulty PCM
Enable Conditions	Case 1 <ul style="list-style-type: none"> • Intake air temperature(IAT) > -25°C(-13°F) • Engine state=Run • No errors in relative sensors • Engine should be cool enough 	
	Case 2 <ul style="list-style-type: none"> • Intake air temperature(IAT) > -25°C(-13°F) • Engine state=Run • No errors in relative sensors • Engine should be cool enough 	
Threshold value	Case 1 <ul style="list-style-type: none"> • Temperature difference between TM oil temp and coolant temp > 20°C(68°F) • TM oil temp > coolant temp 	
	Case 2 <ul style="list-style-type: none"> • Temperature difference between TM oil temp and coolant temp > 20°C(68°F) • TM oil temp > coolant temp • Absolute value of temperature difference between minimum IAT and coolant temp at key on < 10°C(50°F) • Absolute value of temperature difference between maximum IAT and coolant temp at key on < 10°C(50°F) 	
Diagnostic Time	<ul style="list-style-type: none"> • 1 second 	
Fail Safe	<ul style="list-style-type: none"> • Fluid temperature is regarded as 85°C(185°F) 	

SPECIFICATION EB6873B5

Temp.[°C(°F)]	Resistance^)	Temp.[°C(°F)]	Resistance(kS)
-40(-40)	139.5	80(176)	1.08
-20(-4)	47.7	100(212)	0.63
0(32)	18.6	120(248)	0.38
20(68)	8.1	140(284)	0.25
40(104)	3.8	160(320)	0.16
60(140)	1.98		

TERMINAL & CONNECTOR INSPECTION EBFCFTFO

1. Many malfunctions in the electrical system are caused by poor harness and terminals. Faults can also be caused by interference from other electrical systems, and mechanical or chemical damage.
2. Thoroughly check connectors for looseness, poor connection, bending, corrosion, contamination, deterioration, or damage.
3. Has a problem been found?

YES

- Repair as necessary and go to "Verification vehicle repair" procedure.

NO

- Go to "Component inspection" procedure.

COMPONENT INSPECTION EDCODECE

1. CHECK "TRANSAXLE FLUID TEMPERATURE SENSOR"
 - 1) Ignition "OFF".
 - 2) Disconnect the "TRANSAXLE FLUID TEMPERATURE SENSOR" connector.
 - 3) Measure the resistance between terminals "1" and "2" of the "TRANSMISSION FLUID TEMPERATURE SENSOR".

Specification : Refer to "Reference data"

[REFERENCE DATA]

Temp.[°C(°F)]	Resistance(kS)	Temp.[°C(°F)]	Resistance^)
-40(-40)	139.5	80(176)	1.08
-20(-4)	47.7	100(212)	0.63
0(32)	18.6	120(248)	0.38
20(68)	8.1	140(284)	0.25
40(104)	3.8	160(320)	0.16
60(140)	1.98		

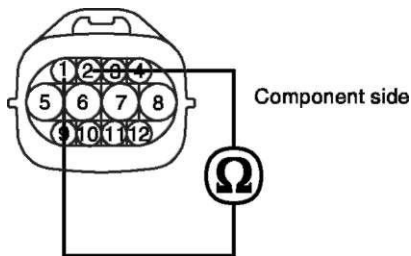

1 TRANSMISSION FLUID TEMPERATURE SENSOR
2.Sensor ground

4) Is resistance within specifications?

YES

- Go to "CHECK PCM" as below.

NO

- Replace "TRANSAXLE FLUID TEMPERATURE SENSOR" as necessary and go to "Verification vehicle repair" procedure.

2. CHECK PCM

- 1) Ignition "ON" & Engine "OFF".
- 2) Connect "TRANSAXLE FLUID TEMPERATURE SENSOR" connector.
- 3) Install scantool and select a SIMU-SCAN.
- 4) Simulate voltage (0—5V) to "TRANSMISSION FLUID TEMPERATURE SENSOR" signal circuit.

1.7 SIMU-SCAN				1.7 SIMU-SCAN			
12. BED SO DUTV	0.0 %			12. BED SO DUTV	0.0 >.		
13.011, TEMPEBATUEE	284 *F			13.011 TEMPEEATUEE	212 "F		
14. GEAE POSITION	N, P, B	•		14. GEAE POSITION	N, P, E	•	
15. SELECT LEVER POSI.	P, N	T		15. SELECT LEUER POSI.	P, N	T	
SIMULATION OF UOLTAGE				SIMULATION OF UOLTAGE			
2.09 V				3.22 V			
(CH B ONLV)				(CH B ONLV)			
METB	SI ML	+	FIK	METB	SI ML	+	FIK
FIG.1)				FIG.2)			

FIG.1) INPUT 2.09V 140°C(284°F)

FIG.2) INPUT 3.22V → 100°C(212°F)

% The values are subject to change according to vehicle model

EKRF702B

5) Is FLUID TEMP. SENSOR signal value changed according to simulation voltage?

- Thoroughly check connectors for looseness, poor connection, bending, corrosion, contamination, deterioration, or damage. Repair or replace as necessary and then go to "Verification of vehicle repair" procedure.

NO

- Substitute with a known-good PCM and check for proper operation. If the problem is corrected, replace PCM as necessary and then go to "Verification of vehicle repair" procedure.

VERIFICATION OF VEHICLE REPAIR EED4D1B.

After a repair, it is essential to verify that the fault has been corrected.

1. Connect scan tool and select "Diagnostic Trouble Codes(DTCs)" mode.
2. Using a scantool, Clear DTC.
3. Operate the vehicle within DTC Enable conditions in General information.
4. Are any DTCs present?

YES

- Go to the applicable troubleshooting procedure.

NO

- System performing to specification at this time.

DTC P0712 FLUID(OIL) TEMPERATURE SENSOR CIRCUIT - LOW

COMPONENT LOCATION E1D,A,A4

Refer to DTC P0711.

GENERAL DESCRIPTION E5BDFB78

Refer to DTC P0711.

DTC DESCRIPTION E251AE90

PCM displays this code if it detects the condition below for more than 10 seconds. PCM recognizes that the oil temperature is 85°C(185°F) since this code is sensed.

DTC DETECTING CONDITION E3A8FFFD

Item	Detecting Condition & Fail Safe	Possible cause
DTC Strategy	<ul style="list-style-type: none">• Check for ground short	<ul style="list-style-type: none">• Sensor signal circuit is short to ground• Faulty sensor• Faulty PCM
Enable Conditions	<ul style="list-style-type: none">• Engine state=Run	
Threshold value	<ul style="list-style-type: none">• Temperature Input A/D value < 1.4%	
Diagnostic Time	<ul style="list-style-type: none">• More than 10 seconds	
Fail Safe	<ul style="list-style-type: none">• Fluid temperature is regarded as 85°C(185°F)	

SPECIFICATION EE60A991

Refer to DTC P0711.

MONITOR SCANTOOL DATA EEDF18BA

1. Connect scantool to data link connector(DLC).
2. Engine "ON".
3. Monitor the "TRANSAXLE FLUID TEMPERATURE SENSOR" parameter on the scantool.

Specification : Increasing gradually

1.2 CUBBENT DATA		13/24
K	13. OIL TEMPERATURE 147 14. GEAB POSITION 15. SELECT LEVEE POSI. 16. A/C SWITCH 17. IDLE SWITCH 13. BRAKE SWITCH 19. SPOBTS MODE SELECT 20. SPOBTS MODE UP SW	A •
FIX PART FULL HELP GBPH BOBB		

FIG.1)

1.2 CUBBENT DATA	13/24
13.OIL TEMPEEATUBE 14. GEAE POSITION 15. 3I 16. A signal circuit open 17.1 18. BhFiKE snrrcFT 19.SPOBTS MODE SELECT 2B.SPOBTS MODE UP SW	
FIK PAST FULL HELP GBPH ECED	

FIG.2)

1.2 CUBBENT DATA	13/24
13. OIL TEMPERATURE 14. GEAK POSITION 15. SI 18. A/ signal circuit short to ground 17. II 18. BI 1 1 1 1 1 19. SPOBTS MODE SELECT 20. SPOBTS MODE UP SW	
FIK PART FULL HELP GRPH RCRD	

FIG.3)

- FIG.1) Normal
- FIG.2) Signal harness Open
- FIG.3) Signal harness Short

ELQE013A

4. Does "TRANSAXLE FLUID TEMPERATURE SENSOR " follow the reference data?

- Fault is intermittent caused by poor contact in the sensor's and/or PCM's connector or was repaired and PCM memory was not cleared. Thoroughly check connectors for looseness, poor connection, bending, corrosion, contamination, deterioration or damage. Repair or replace as necessary and go to "Verification vehicle repair" procedure.

NO

- Go to "Terminal & connector inspection" procedure.

TERMINAL & CONNECTOR INSPECTION EDDSDEBE

Refer to DTC P0711.

SIGNAL CIRCUIT INSPECTION EE2A7AEE

1. Ignition "ON" & Engine "OFF".
2. Disconnect the "TRANSAXLE FLUID TEMPERATURE SENSOR" connector.
3. Measure the voltage between terminal "1" of the "TRANSMISSION FLUID TEMPERATURE SENSOR" harness connector and chassis ground.

Specification : Approx. 5V

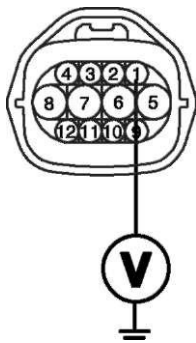

1 TRANSMISSION FLUID TEMPERATURE SENSOR
2.Sensor ground

EKRF703A

4. Is voltage within specifications?

YES

- Go to "Component inspection" procedure.

NO

- Check for short to ground in harness. Repair as necessary and go to "Verification vehicle repair" procedure.

COMPONENT INSPECTION E026604F

Refer to DTC P0711.

VERIFICATION OF VEHICLE REPAIR E,7DA,1F

Refer to DTC P0711.

DTC P0713 FLUID(OIL) TEMPERATURE SENSOR CIRCUIT - HIGH

COMPONENT LOCATION E9844194

Refer to DTC P0711.

GENERAL DESCRIPTION E68A7FFE

Refer to DTC P0711.

DTC DESCRIPTION E1837D5B

Refer to DTC P0711.

DTC DETECTING CONDITION ECBF9CB9

Item	Detecting Condition & Fail Safe	Possible cause
DTC Strategy	<ul style="list-style-type: none"> • Check for voltage range 	<ul style="list-style-type: none"> • Sensor signal circuit is short to ground • Faulty sensor • Faulty PCM
Enable Conditions	<ul style="list-style-type: none"> • Intake air temperature(IAT) > -25°C(-13°F) • Engine state=Run • No errors in relative sensors 	
Threshold value	<ul style="list-style-type: none"> • Temperature Input A/D value > 98% • No rise in oil temperature after enough time passed 	
Diagnostic Time	<ul style="list-style-type: none"> • More than 1 sec 	
Fail Safe	<ul style="list-style-type: none"> • Fluid temperature is regarded as 85°C(185°F) 	

SPECIFICATION E8DE74AE

Refer to DTC P0711.

MONITOR SCANTOOL DATA E7,FAA1B

Refer to DTC P0712.

TERMINAL & CONNECTOR INSPECTION E,,EB2EE

Refer to DTC P0711.

SIGNAL CIRCUIT INSPECTION E8D34AC4

Refer to DTC P0712.

GROUND CIRCUIT INSPECTION EDFABBB4

1. Ignition "OFF".
2. Disconnect the "TRANSAXLE FLUID TEMPERATURE SENSOR" connector.
3. Measure the resistance between terminal "2" of the "TRANSMISSION FLUID TEMPERATURE SENSOR" harness connector and chassis ground.

Specification : Approx. 0 Ω

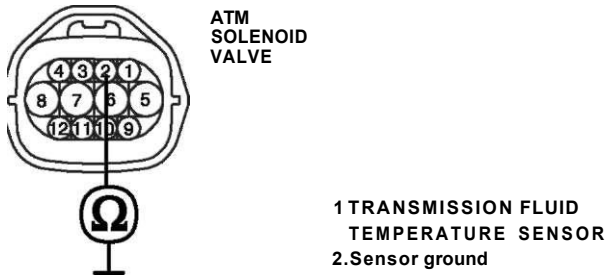

EKRF704A

4. Is resistance within specifications?

YES

- Go to "Component inspection" procedure.

NO

- Check for open in harness. Repair as necessary and Go to "Verification vehicle repair" procedure.

COMPONENT INSPECTION E7C8C8FF

Refer to DTC P0711.

VERIFICATION OF VEHICLE REPAIR EOIBED,D

Refer to DTC P0711.

DTC P0717 INPUT SPEED SENSOR CIRCUIT - NO SIGNAL

COMPONENT LOCATION EID,,A55

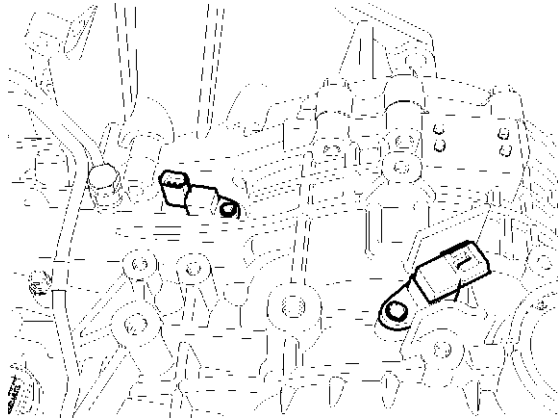

GENERAL DESCRIPTION E974CAE2

The input(turbine) speed sensor outputs pulse-signals according to the revolutions of the input shaft of the transmission. The PCM determines the input shaft speed by counting the frequency of the pulses. This value is mainly used to control the optimum fluid pressure during shifting.

DTC DESCRIPTION EAEDDE4C

The PCM sets this code if an output pulse-signal is not detected from the input speed sensor, when the vehicle is running faster than 30 km/h. The Fail-Safe function will be set by the PCM if this code is detected.

DTC DETECTING CONDITION E,,IF,F6

Item	Detecting Condition & Fail Safe	Possible cause
DTC Strategy	<ul style="list-style-type: none"> • Speed rationality check 	<ul style="list-style-type: none"> • Signal circuit is open or short • Sensor power circuit is open • Sensor ground circuit is open • Faulty INPUT SPEED SENSOR • Faulty PCM
Enable Conditions	<ul style="list-style-type: none"> • Engine state=Run • Vehicle Speed > 30km/h • Engine RPM at current gear 1 or 2 or Non conditional VRPM when gear is not 1 or 2 > 1000rpm • Battery voltage > 11V and < 16 V • AT oil temp. > -23°C(-9.4°F) • No error in speed sensors 	
Threshold value	<ul style="list-style-type: none"> • No signal 	
Diagnostic Time	<ul style="list-style-type: none"> • More than 1sec 	
Fail Safe	<ul style="list-style-type: none"> • The gear shift position is recognized as follows. 'P' range -> realization as 'N' range 'R' range -> realization as 'R' range 'N' range -> realization as 'N' range 'D' range -> realization as 3 range SPT mode -> CAN shift 2-3 range 	

SPECIFICATION E72A1E2B

Input shaft & Output shaft speed sensor

- Type : Hall sensor
- Current consumption : 22mA(MAX)
- Sensor body and sensor connector have been unified as one.

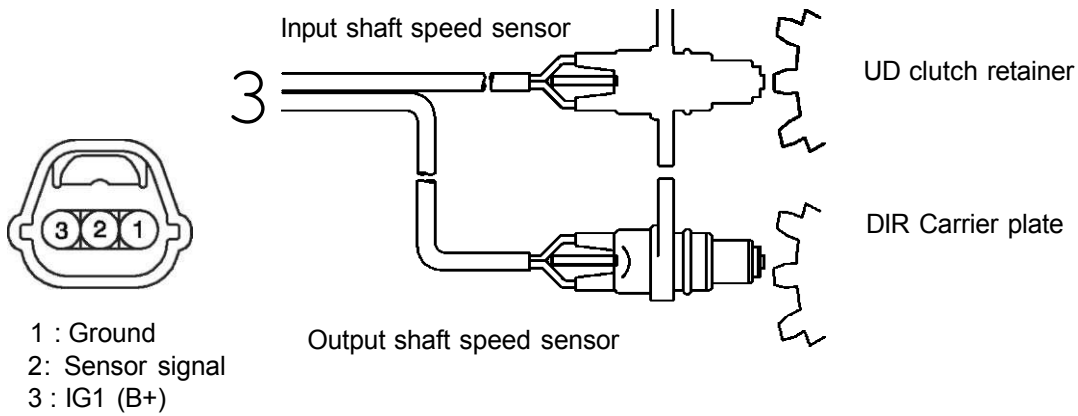

EKRF705A

Air gap (mm)	Input shaft speed sensor	1.3
	Output shaft speed sensor	0.85
Insulation Resistance	Input shaft speed sensor	over 1MQ
	Output shaft speed sensor	over 1Mfl
Peak-Peak Voltage	High	more than 4.8V
	Low	less than 0.8V

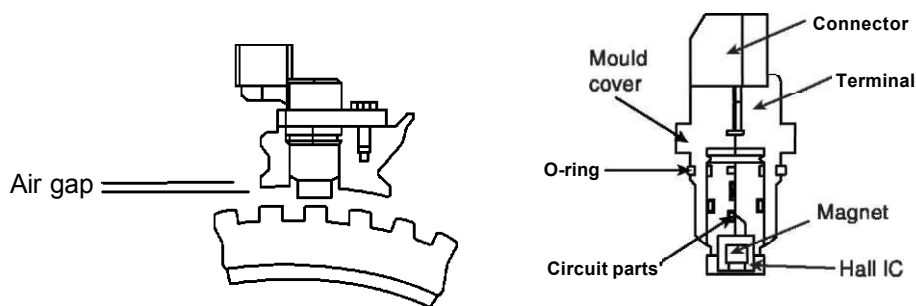

EKRF705B

SIGNAL WAVEFORM E2E6BC3C

1U E E 1"
M Y'h -IV ft Ho Trig
r 1\

V n

.....

FIG.1)

FIG.2)

FIG.1) Idling
FIG.2) Accelerating

EKRF705C

MONITOR SCANTOOL DATA EC883903

- 1. Connect scantool to data link connector(DLC).
2. Engine "ON" .
3. Monitor the "INPUT SPEED SENSOR" parameter on the scantool
4. Driving at speed of over 30 Km/h(19 mph).

Specification : Increasing Gradually

1. 2 CURRENT DATA

1. 2 CURRENT DATA

CRK POSITION SNSR 9B3 rpn
INPUT SPEED SNSH
OUTPUT SPEED SNSR 321
UEHICLE SPEED 8
SHIFT POSITION 1
TCC SLIP (AMOUNT] 49 rpm
A^T RELAV UOLT 14. 3 W
THANSAHLE RANGE SU D

3

CRM POSITION SNSH 2082 rpn
INPUT SPEED SNSH 1957 rpn
OUTPUT SPEED SNSR 2152 rpn
UEHICLE SPEED 72 Kn^li
SHIFT POSITION 4
TCC SLIP (AMOUNT] 105 rpn
A/T RELAV UOLT 14. 3 U
TRANSAKLE RANGE SU D

SCRN FULL PAET GRPH HELP

FIK SCHN FULL PAET GRPH HELP

FIG.1)

FIG.2)

FIG.1) Idling
FIG.2) Accelerating

ELQE018A

5. Does "input speed sensor" follow the reference data?

- Fault is intermittent caused by poor contact in the sensor's and/or PCM's connector or was repaired and PCM memory was not cleared. Thoroughly check connectors for looseness, poor connection, bending, corrosion, contamination, deterioration or damage. Repair or replace as necessary and go to "Verification vehicle repair" procedure.

- Go to "Terminal & connector inspection" procedure.

TERMINAL & CONNECTOR INSPECTION EB,CBD,C

1. Many malfunctions in the electrical system may be caused from poor harness and terminals. These faults can be caused by interference from other electrical systems and mechanical or chemical damage.
2. Thoroughly check connectors for looseness, poor connection, bending, corrosion, contamination, deterioration, or damage.
3. Has a problem been found?

- Repair as necessary and go to "Verification vehicle repair" procedure.

- Go to "Signal circuit inspection" procedure.

SIGNAL CIRCUIT INSPECTION E68F9B70

1. Ignition "ON" & Engine "OFF".
2. Disconnect the "INPUT SPEED SENSOR" connector.
3. Measure voltage between terminal "2" of the INPUT SPEED SENSOR harness connector and chassis ground.

Specification : approx. 5V

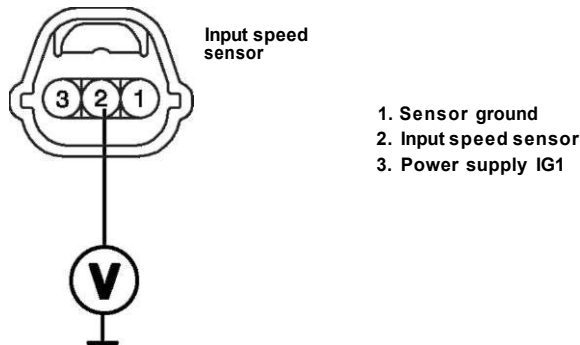

4. Is voltage within specification?

YES

- Go to "Power supply circuit inspection" procedure.

NO

- Check for open or short in harness. Repair as necessary and Go to "Verification vehicle repair" procedure.
- If signal circuit in harness is OK, go to "Check PCM" of the "Component inspection" procedure.

POWER SUPPLY CIRCUIT INSPECTION Eaaofic

1. Ignition "ON" & Engine "OFF".
2. Disconnect the "INPUT SPEED SENSOR" connector.
3. Measure voltage between terminal "3" of the INPUT SPEED SENSOR harness connector and chassis ground.

Specification : approx. B+

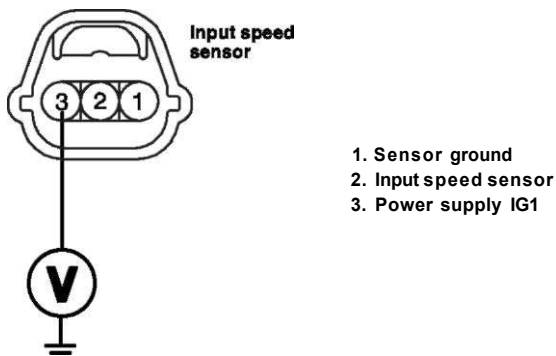

EKRF705E

4. Is voltage within specification ?

- Go to "Ground circuit inspection" procedure.
- Check for open in harness. Repair as necessary and go to "Verification vehicle repair" procedure.

GROUND CIRCUIT INSPECTION EECA50DE

1. Ignition "ON" & Engine "OFF".
2. Disconnect the "INPUT SPEED SENSOR" connector.
3. Measure resistance between terminal "1" of the INPUT SPEED SENSOR harness connector and chassis ground.

Specification : approx. 0 Ω

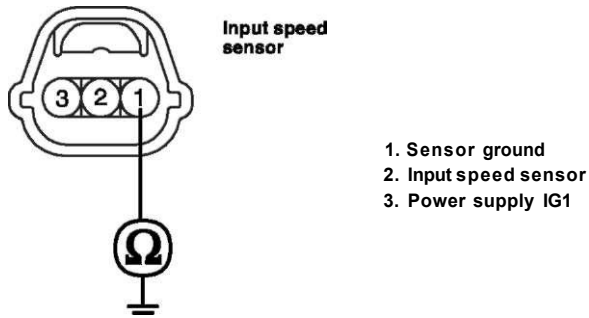

EKRF705F

4. Is resistance within specification ?

YES

- Go to "Component inspection" procedure.

NO

- Check for open in harness. Repair as necessary and go to "Verification vehicle repair" procedure.
- If ground circuit in harness is OK, go to "Check PCM" of the "Component inspection" procedure.

COMPONENT INSPECTION EBFC3C32

1. Check "INPUT SPEED SENSOR"
 - 1) Ignition "OFF".
 - 2) Disconnect the "INPUT SPEED SENSOR" connector.
 - 3) Measure resistance between terminal "1", "2" and "2", "3" and "1", "3" of the "INPUT SPEED SENSOR" connector.

Specification : Refer to "Reference data"

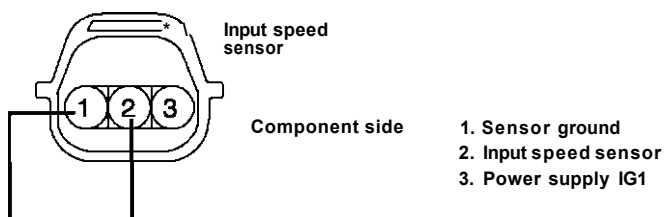

EKRF705G

- 4) Is resistance within specification?

[REFERENCE DATA]

Air gap (mm)	Input shaft speed sensor	1.3
	Output shaft speed sensor	0.85
Insulation Resistance	Input shaft speed sensor	over 1Mfl
	Output shaft speed sensor	over 1Mfl
Peak-Peak Voltage	High	more than 4.8V
	Low	less than 0.8V

YES

- Go to "CHECK PCM" as below.

NO

- Replace "INPUT SPEED SENSOR" as necessary and go to "Verification vehicle repair" procedure.

2. CHECK PCM

- 1) Ignition "ON" & Engine "OFF".
- 2) Connect "INPUT SPEED SENSOR" connector.
- 3) Install scantool and select a SIMU-SCAN.
- 4) Simulate frequency to INPUT SPEED SENSOR signal circuit.

1. 7 SIMU-SCAN						1. 7 SIMU-SCAN					
04. INPUT SPEED SENS	150	i	-pn	k	•	04. INPUT SPEED SENS	251	rpn	i	•	T
05. O/PUT SPEED SENS	B	r	p	m	•	05. O/PUT SPEED SENS	0	rpn	•	•	T
06. DCCSU DUTY	8.0	%				06. DCCSU DUTY	0.8	X			
07. DAMP. CLUTCH SLIP	-150	rpn				07. DAMP. CLUTCH SLIP	-251	rpn			
SIMULATION OF FEEQUENCY FREQUENCY DUTY						SIMULATION OF FEEQUENCY FEEQUENCY DUTY					
t CH B ONLY)						(CH B ONLY)					
METE	SIML	SLCT	+	-	FIK	METB	SIML	SLCT	+	-	FIK
FIG.1)						FIG.2)					

FIG.1) INPUT 150Hz -> 150rpm

FIG.2) INPUT 250Hz -> 251 rpm

5) Is "INPUT SPEED SENSOR" signal value changed according to simulation frequency?

YES

- Thoroughly check connectors for looseness, poor connection, bending, corrosion, contamination, deterioration, or damage. Repair or replace as necessary and then go to "Verification of vehicle repair" procedure.

NO

- Substitute with a known-good PCM and check for proper operation. If the problem is corrected, replace PCM as necessary and then go to "Verification of vehicle repair" procedure.

VERIFICATION OF VEHICLE REPAIR EC4ADBOB

After a repair, it is essential to verify that the fault has been corrected.

1. Connect scan tool and select "Diagnostic Trouble Codes(DTCs)" mode.
2. Using a scantool, Clear DTC.
3. Operate the vehicle within DTC Enable conditions in General information.
4. Is resistance within specification ?

- Go to the applicable troubleshooting procedure.

NO

- System performing to specification at this time.

DTC P0722 OUTPUT SPEED SENSOR CIRCUIT - NO SIGNAL

COMPONENT LOCATION E71ACE52

Refer to DTC P0717.

GENERAL DESCRIPTION EEDDEE8D

The output speed sensor calculates the number of rotations of the transfer drive gear, which means that the sensor calculates the frequency of electric signal that is occurred at the transfer drive gear's rotating. The signal is inputted to the PCM and is used as the main signal which decides the optimum gear position with TPS signal.

DTC DESCRIPTION EC340BCC

The PCM sets this code if the calculated value of the pulse-signal from the output speed sensor is noticeably different from the calculated value from vehicle speed sensor, when the vehicle is running faster than 30 km/h. The PCM will initiate the fail safe function if this code is detected.

DTC DETECTING CONDITION E6C435A9

Item	Detecting Condition & Fail Safe	Possible cause
DTC Strategy	<ul style="list-style-type: none"> • Speed rationality check 	<ul style="list-style-type: none"> • Signal circuit is open or short • Sensor power circuit is open • Sensor ground circuit is open • Faulty OUTPUT SPEED SENSOR • Faulty PCM
Enable Conditions	<ul style="list-style-type: none"> • Engine state=Run • Vehicle Speed > 30km/h • Engine RPM at current gear 1 or 2 or Non conditional VRPM when gear is not 1 or 2 > 1000rpm • Battery voltage > 11V and < 16 V • AT oil temp. £ -23°C(-9.4°F) • No error in speed sensors 	
Threshold value	<ul style="list-style-type: none"> • Vehicle speed calculated from TM output speed sensor < 50% * the vehicle speed from vehicle speed sensor 	
Diagnostic Time	<ul style="list-style-type: none"> • More than 1sec 	
Fail Safe	<ul style="list-style-type: none"> • Not in shifting process: The output speed sensor value have been received by calculation from the input speed sensor signal. • In shifting process: Instead of the output speed sensor signal, the vehicle speed sensor signal is used. 	

SPECIFICATION E14AEBDB

Refer to DTC P0717.

SIGNAL WAVEFORM E2CEFF7B

Refer to DTC P0717.

MONITOR SCANTOOL DATA E82AB8CD

1. Connect scantool to data link connector (DL) *AutoLibrary*

2. Engine "ON".
3. Monitor the "OUTPUT SPEED SENSOR" parameter on the scantool.
4. Driving at speed of over 30 Km/h(19 mph).

Specification : Increasing Gradually

1. 2 CUBHEMI DATA			
X	CRK POSITION SNSH	1146	rpn
X	INPUT SPEED SNSE	1143	rpn •
X	OUTPUT SPEED SNSH	4B8	rpn
X	OEHICLE SPEED	11	Kn/h
X	SHIFT POSITION	1	
	TCC SLIP (AMOUNT 1	49	rpn
	A/T BELAY UOLT	14.2	U
	TBANSAXLE BANCE SU	D	

FIK SCEN FULL PAST GBPH HELP

FIG.1)

1. Z CUBBENT DATA			
X	CRK POSITION SNSB	1684	rpn
X	INPUT SPEED SNSE	1664	rpn •
X	OUTPUT SPEED SNSB	2247	rpn
X	OEHICLE SPEED	7B	Kn/h
X	SHIFT POSITION	4	
	TCC SLIP (AMOUNT 1	84	rpn
	A/T BELAY UOLT	14.2	0
	TBANSAXLE BANCE SU	D	

FIK SCEN FULL PAST GBPH HELP

FIG.2)

0

FIG. 1) Low-speed

FIG. 2) High-speed

5. Does "Output speed sensor" follow the reference data?

- Fault is intermittent caused by poor contact in the sensor's and/or PCM's connector or was repaired and PCM memory was not cleared. Thoroughly check connectors for looseness, poor connection, bending, corrosion, contamination, deterioration or damage. Repair or replace as necessary and go to "Verification vehicle repair" procedure.

- Go to "Terminal & connector inspection" procedure.

TERMINAL & CONNECTOR INSPECTION ECIBASBA

Refer to DTC P0717.

SIGNAL CIRCUIT INSPECTION E0CDAF6A

1. Ignition "ON" & Engine "OFF".
2. Disconnect the "OUTPUT SPEED SENSOR" connector.
3. Measure voltage between terminal "2" of the OUTPUT SPEED SENSOR harness connector and chassis ground.

Specification : approx. 5V

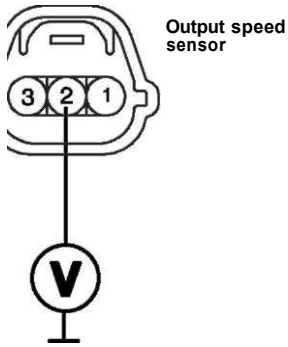

- 1. Sensor ground
- 2. Output speed sensor
- 3. Power supply IG1

EKRF706A

4. Is voltage within specification?

- Go to "Power supply circuit inspection" procedure.
- Check for open or short in harness. Repair as necessary and go to "Verification vehicle repair" procedure.
- If signal circuit in harness is OK, go to "Check PCM" of the "Component inspection" procedure.

POWER SUPPLY CIRCUIT INSPECTION E2AFEADD

1. Ignition "ON" & Engine "OFF".
2. Disconnect the "OUTPUT SPEED SENSOR" connector.
3. Measure voltage between terminal "3" of the OUTPUT SPEED SENSOR harness connector and chassis ground.

Specification : approx. B+

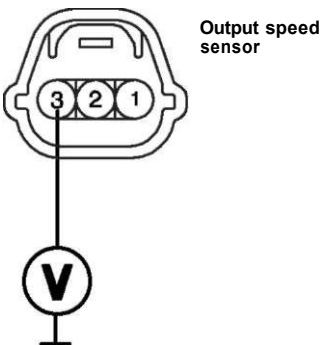

- 1. Sensor ground
- 2. Output speed sensor
- 3. Power supply IG1

EKRF706B

4. Is voltage within specification?

- Go to "Ground circuit inspection" procedure.
- Check for open in harness. Repair as necessary and go to "Verification vehicle repair" procedure.

GROUND CIRCUIT INSPECTION EC5DB45A

1. Ignition "ON" & Engine "OFF".
2. Disconnect the "OUTPUT SPEED SENSOR" connector.
3. Measure resistance between terminal "1" of the OUTPUT SPEED SENSOR harness connector and chassis ground.

Specification : approx. 0 Ω

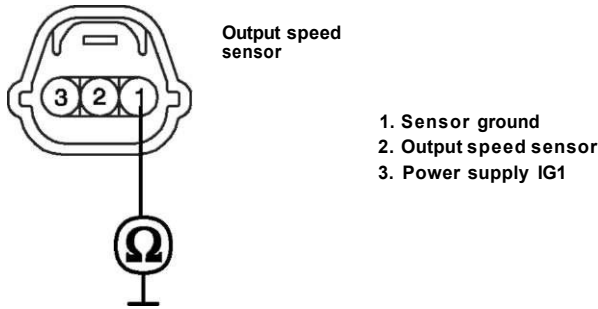

EKRF706C

4. Is resistance within specification?

- Go to "Component inspection" procedure.
- Check for open in harness. Repair as necessary and go to "Verification vehicle repair" procedure.
- If ground circuit in harness is OK, go to "Check PCM" of the "Component inspection" procedure.

COMPONENT INSPECTION ECAFOBID

1. Check "OUTPUT SPEED SENSOR"
 - 1) Ignition "OFF".
 - 2) Disconnect the "OUTPUT SPEED SENSOR" connector.
 - 3) Measure resistance between terminal "1", "2" and "2", "3" and "1", "3" of the "OUTPUT SPEED SENSOR" connector.

Specification : Refer to "Reference data"

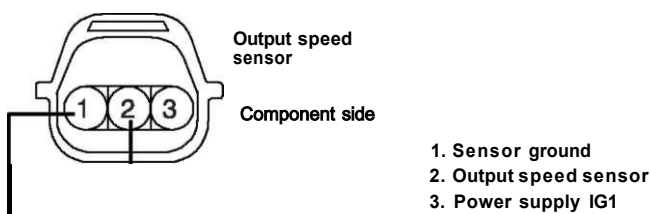

4) Is resistance within specifications?

[REFERENCE DATA]

Air gap (mm)	Input shaft speed sensor	1.3
	Output shaft speed sensor	0.85
Insulation Resistance	Input shaft speed sensor	over 1Mfl
	Output shaft speed sensor	over 1MQ
Peak-Peak Voltage	High	more than 4.8V
	Low	less than 0.8V

- Go to "CHECK PCM" as below.

- Replace "OUTPUT SPEED SENSOR" as necessary and go to "Verification vehicle repair" procedure.

2. CHECK PCM

- 1) Ignition "ON" & Engine "OFF".
- 2) Connect "OUTPUT SPEED SENSOR" connector.
- 3) Install scantool and select a SIMU-SCAN.
- 4) Simulate frequency to OUTPUT SPEED SENSOR signal circuit.

1. 7 SIMU-SCAN

```

05.0/PUT SPEED SENS0E    150 rpn
06. DCCSO DUTV           0.0 A
07. DAMP.CLUTCH SLIP     0 rpn
08. LSB SO DUTV          0.0 %
    
```

SIMULATION OF FREQUENCY

FREQUENCY	DUTV
84 Hz	5B %
(CH B ONLY)	

METE SIML SLCT - FIK

FIG.1)

1. 7 SIMU-SCAN

```

05.0/PUT SPEED SENSOR    251 rpn
06. DCCSO DUTV           0.0 A
07. DAMP.CLUTCH SLIP     0 rpn
08. LSB SO DUTV          100.0%
    
```

SIMULATION OF FREQUENCY

FREQUENCY	DUTV
139 Hz	5B %
(CH B ONLY)	

METE SIML SLCT - FIK

FIG.2)

FIG. 1) OUTPUT 84Hz → 150rpm
 FIG. 2) OUTPUT 139Hz → 251 rpm

5) Is "OUTPUT SPEED SENSOR" signal value changed according to simulation frequency?

YES

- Thoroughly check connectors for looseness, poor connection, bending, corrosion, contamination, deterioration, or damage. Repair or replace as necessary and then go to "Verification of vehicle repair" procedure.

NO

- Substitute with a known-good PCM and check for proper operation. If the problem is corrected, replace PCM as necessary and then go to "Verification of vehicle repair" procedure.

VERIFICATION OF VEHICLE REPAIR ESE2BFBA

Refer to DTC P0717.

DTC P0731 GEAR 1 INCORRECT RATIO

COMPONENT LOCATION EF38FCAF

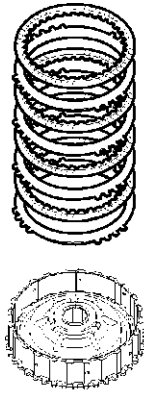

UD clutch

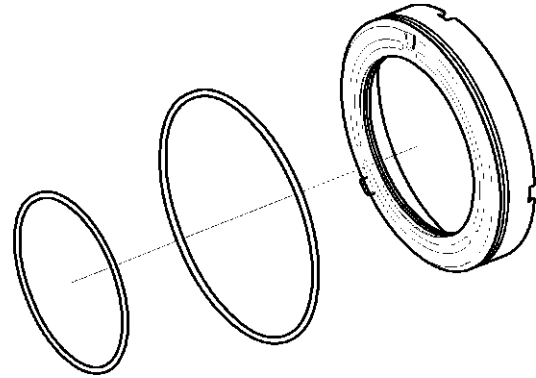

L&R brake

EKRF707A

GENERAL DESCRIPTION EE59C7FC

The input shaft speed in gear 1 range should be the similar to the value that is what the gear 1 ratio and the output shaft speed are multiplied. For example, if the output shaft speed is 1,000 rpm and the gear 1 ratio is 3.789, the input shaft speed may be about 3,789 rpm.

DTC DESCRIPTION EE5CAE1B

This code is displayed if the input shaft speed does not conform with the value which is what the output shaft speed and the gear 1 ratio are multiplied. This is more probably caused by a mechanical defect of adherence of control valves or a breakdown of solenoid controlled valves etc. than a electrical defect.

DTC DETECTING CONDITION E6F8FCB3

Item	Detecting Condition & Fail Safe	Possible cause
DTC Strategy	<ul style="list-style-type: none"> • 1st gear incorrect ratio 	<ul style="list-style-type: none"> • Faulty input speed sensor • Faulty output speed sensor • Faulty UD clutch or LR brake or Oneway clutch
Enable Conditions	<ul style="list-style-type: none"> • Engine state=Run • Battery Voltage > 11V and < 16 V • TM oil temperature > -23°C(-9.4°F) • Engine speed > 450rpm • TM output speed > 150rpm • TM Input speeds Orpm • Current gear= 1st • Gear shifting is completed • No PRNDL fail • No error in speed sensors 	
Threshold value	<ul style="list-style-type: none"> • Measured input speed - calculated input speed > 200 rpm 	
Diagnostic Time	<ul style="list-style-type: none"> • More than 1sec 	
Fail Safe	<ul style="list-style-type: none"> • Locked into 3rd gear. 	

SIGNAL WAVEFORM

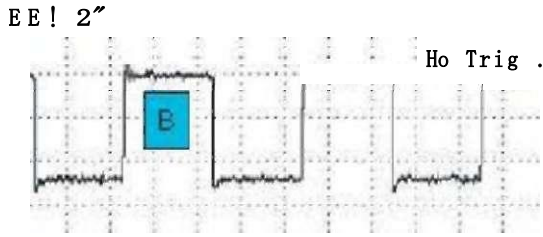

FIG.1)

A: INPUT SPEED SENSOR
B : OUTPUT SPEED SENSOR

EKRF707B

MONITOR SCANTOOL DATA ECC92C0F

1. Connect scantool to data link connector(DLC).
2. Engine "ON".
3. Monitor the "ENGINE SPEED, INPUT SPEED SENSOR, OUTPUT SPEED SENSOR, GEAR POSITION" parameter on the scantool.
4. Perform the "STALL TEST" with gear position "1"

Specification : 2700-2900 engine rpm

1. Z CURRENT DATA

* CRK POSITION SNSR	2329 rpn
INPUT SPEED SNSR	B rpn
OUTPUT SPEED SNSR	0 rpn
SHIFT POSITION	1
THROTTLE P. SENSOR	39.2 %
FLUID TEHP. SENSOR	86 °C
VEHICLE SPEED	0 Km/h
LKRSO DUTY	0.0 %

FIX SCEN FULL PART GRPH HELP

ELQE032A

OPERATING ELEMENT OF EACH SHIFTING RANGE

Range	UD clutch	OD clutch	2ND brake	LR brake	REV clutch	RED clutch	DIR clutch	owe	OWC1	
P	-	-	-	0	-	0	-	-	-	
R	-	-	-	0	0	0	-	-	-	
N	-	-	-	0	-	0	-	-	-	
D	1st	0	-	-	0	-	0	-	0	0
	2nd	0	-	0	-	-	0	-	0	-
	3rd	0	0	-	-	-	0	-	0	-
	4th	-	0	0	-	-	0	-	0	-
	5th	-	0	0	-	-	-	0	-	-

- UD/C : Underdrive clutch
- OD/C : Overdrive clutch
- 2ND/B : 2ND brake
- LR/B : Low & Reverse brake
- REV/C: Reverse clutch
- RED/B: Reduction brake
- DIR/C: Direct clutch
- OWC : One way clutch for sub gear shifting
- OWC1 : One way clutch for main gear shifting

Stall test procedure in D1 and reason

Procedure

1. Warm up the engine
2. After positioning the select lever in "D", depress the foot brake pedal fully. After that, depress the accelerator pedal to the maximum

* The slippage of 1st gear operating parts can be detected by stall test in D.

Reason for stall test

1. If there is no mechanical defaults in A/T, all slippage occurs in torque converter.
 2. Therefore, engine revolution is output, but input and output speed revolution must be "zero" due to wheel's lock.
 3. If 1st gear operating part has faults, input speed revolution will be out of specification.
 4. If output speed revolution is output. It means that the foot brake force is not applied fully. Remeasuring is required.
5. Is "STALL TEST " within specification?

YES

- Go to "Signal circuit inspection" procedure.

NO

- Go to "Component inspection" procedure.

A CAUTION

- Do not let anybody stand in front of or behind the vehicle while this test is being carried out.
- Check the A/T fluid level and temperature and the engine coolant temperature.
 - Fluid level: At the hot mark on the oil level gauge.
 - Fluid temperature : 80~100° C (176°F~ 212°F).
 - Engine coolant temperature : 80~100°C (176°F~ 212°F).
- Check both rear wheel (left and right).
- # Pull the parking brake lever on with the brake pedal fully depressed.
- The throttle should not be left fully open for more than eight second.
- # If carrying out the stall test two or more time, move the select lever to the "AT position and run the engine at 1,000 rpm to let the A/T fluid cool down before carrying out subsequent.

SIGNAL CIRCUIT INSPECTION ECDDF9EE

1. Connect Scantool.
2. Engine "ON".
3. Monitor the "INPUT & OUTPUT SPEED SENSOR" parameter on the scantool.
4. Accelerate the Engine speed until about 2000 rpm in the 1st gear.

Specification : INPUT SPEED - (OUTPUT SPEED * GEAR RATIO) < 200 RPM

-1.2 CURRENT DATA

ENGINE RPM	2127 rpm
INPUT SPEED	2056 rpm
OUTPUT SPEED	730 rpm
SHIFT POSITION	1 GEAR
SELECT LEVER SU.	L
HIUEC NODE	NODE F
VEHICLE SPEED	22 MPH
THROTTLE P. SENSOR	14.1 X

FIX SCEN FULL PAKT GEPH HELP

5. Are "INPUT & OUTPUT SPEED SENSOR" within specifications?

- Go to "Component inspection" procedure.

NO

- Check for electrical noise of circuit in INPUT & OUTPUT SPEED SENSOR or Replace INPUT & OUTPUT SPEED SENSOR. Repair as necessary and Go to "Verification vehicle repair" procedure.

COMPONENT INSPECTION EBBBA290

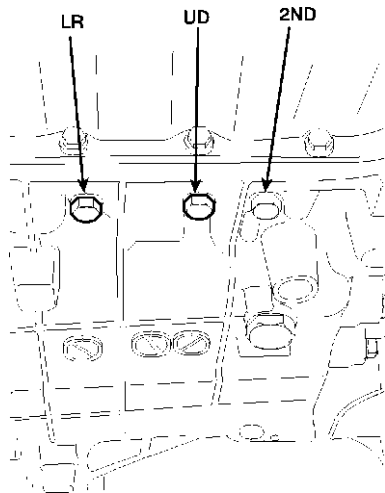

KKCF206E

1. Connect oil pressure gauge to "UD" and "L/R" ports.
2. Engine "ON".
3. Drive a car with gear position 1 in "SPORTS MODE".
4. Compare it with reference data as below.

Specification : shown below

*1 Each case of increasing and decreasing speed.

* 2 Only for 5 speed A/T.

Manual valve position	VFS current [mA]	RPM	Operation (Duty rate %)						Oil pressure MPa {kgf/cm ² }	
			LR	2ND	UD	OD	DCC	RED* ²	UD CLUTCH	LR BRAKE
D	200	2500	0	100	0	100	0	0	1.03±0.02 {10.5±0.2}	1.03±0.02 {10.5±0.2}
			100	0	0	100	0	0	1.03±0.02 {10.5±0.2}	-
R	250		0	100	100	100	0	0	-	1.55±0.25 {15.8±2.5}

Manual valve position (Oil pressure)	VFS current [mA]	RPM	Operation (Duty rate %)						Oil pressure MPa {kgf/cm ² }		
			LR	2ND	UD	OD	DCC	RED* ²	4000	1500 (Decreasing)	600 (Decreasing)
D (LR)	200	600— 4500↗ 600	0	100	0	100	0	0	MAX. 1.11 {MAX. 11.3}	-	MIN. 0.55 {MIN. 5.6}
D(UD)			0	100	0	100	0	0	MAX. 1.11 {MAX. 11.3}	-	MIN. 0.55 {MIN. 5.6}
D(UD)			100	0	0	100	0	0	MAX. 1.11 {MAX. 11.3}	-	MIN. 0.55 {MIN. 5.6}
R(LR)			250	0	100	100	100	0	0	MAX. 1.96 {MAX. 20.0}	MIN. 1.14* ¹ {MIN. 11.6}

Manual valve position (Oil pressure)	VFS current [mA]	RPM	Operation (Duty rate %)						Oil pressure MPa {kgf/cm ² }		
			LR	2ND	UD	OD	DCC	RED* ²	VFS current 200mA	VFS current: 600mA	VFS current: 1100mA
D (UD)	200↗ 1100— 200	2500	100	100	0	0	100	0	1.03±0.02 {10.5±0.2}	0.69±0.03 {7.0±0.3}	0.36±0.03 {3.7±0.3}

Manual valve position	VFS current [mA]	RPM	Operation (Duty rate %)						ELEMENT	P (MPa)
			LR	2ND	UD	OD	DCC	RED*2		
D	200	2500	0	100	0	100	0	0	LR	1.03±0.02
			60	T	T	T	T	T		0.45±0.04
			75	T	T	T	T	T		0.19±0.04
			100	T	T	T	T	T		0
			100	0	0	100	T	0	2ND	1.03±0.02
			T	60	T	T	T	T		0.50±0.05
			T	75	T	T	T	T		0.20±0.05
			T	100	T	T	T	T		0
			100	100	0	0	T	0	OD	1.02±0.02
			T	T	T	60	T	T		0.46±0.04
			T	T	T	75	T	T		0.19±0.04
			T	T	T	100	T	T		0
			100	100	0	0	T	0	UD	1.03±0.02
			T	T	60	T	T	T		0.44±0.05
			T	T	75	T	T	T		0.18±0.04
			T	T	100	T	T	T		0
			100	0	100	0	T	0T	RED	1.03±0.02
			T	T	T	T	T	60		0.49±0.04
			T	T	T	T	T	75		0.24±0.04
			T	T	T	T	T	100		0
			100T	0	100	0	T	100	DIR	0
			75	T	T	T	T	T		0.25±0.04
			60	T	T	T	T	T		0.51±0.04
			0	T	T	T	T	T		1.03±0.02

Each case of increasing (0—'100%) and decreasing (100—'0%) of duty rate to be satisfied.(Except the mark •)

Manual valve position (Oil pressure)	VFS current [mA]	RPM	Operation (Duty rate %)						Damper Apply Pressure ^ (MPa)	Damper Release Pressure (MPa)
			LR	2ND	UD	OD	DCC	RED* ²		
D	200	2500	100	100	0	0	0	0	0.25-0.45	0.50-0.70
			T	T	T	T	50	T	0.20-0.45	0
			T	T	T	T	100	T	0.96-1.04	0
	900		100	100	0	0	0	0	0.12-0.22	0.25-0.45
			T	T	T	T	100	T	MIN. 0.29	0

^ Each case of increasing and decreasing of DCC solenoid duty rate to be satisfied.

The values are subject to change according to vehicle model or condition.

5. Is oil pressure value within specification?

YES

- Repair AUTO TRANSAXLE(Clutch or brake) as necessary and go to "Verification vehicle repair" procedure.

NO

- Replace AUTO TRANSAXLE (BODY CONTROL VALVE faulty) as necessary and go to "Verification vehicle repair " procedure.

VERIFICATION OF VEHICLE REPAIR E,IADF27

After a repair, it is essential to verify that the fault has been corrected.

1. Connect scan tool and select "Diagnostic Trouble Codes(DTCs)" mode.
2. Using a scantool, Clear DTC.
3. Operate the vehicle within DTC Enable conditions in General information.
4. Are any DTCs present ?

- Go to the applicable troubleshooting procedure.

NO

- System performing to specification at this time.

DTC P0732 GEAR 2 INCORRECT RATIO

COMPONENT LOCATION ECCD9F36

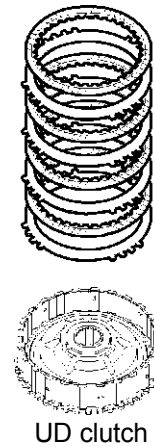
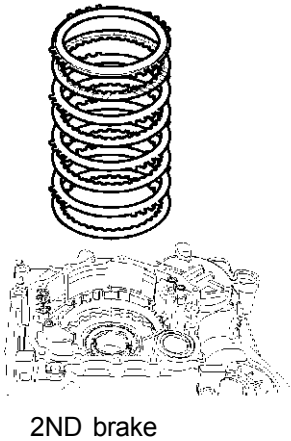

EKRF708A

GENERAL DESCRIPTION E2EDE933

The input shaft speed in gear 2 range should be the similar to the value that is what the gear 2 ratio and the output shaft speed are multiplied. For example, if the output shaft speed is 1,000 rpm and the gear 2 ratio is 2.064, the input shaft speed may be about 2,064 rpm.

DTC DESCRIPTION EDE4AF60

This code is displayed if the input shaft speed does not conform with the value which is what the output shaft speed and the gear 2 ratio are multiplied. This is mainer caused by a mechanical defect of adherence of control valves ora breakdown of solenoid controlled valves etc. than a electrical defect.

DTC DETECTING CONDITION EF3FF3F0

Item	Detecting Condition & Fail Safe	Possible cause
DTC Strategy	<ul style="list-style-type: none"> • 2nd gear incorrect ratio 	<ul style="list-style-type: none"> • Faulty input speed sensor • Faulty output speed sensor • Faulty UD clutch or 2nd brake
Enable Conditions	<ul style="list-style-type: none"> • Engine state= Run • Battery Voltage > 11V and < 16 V • TM oil temperature > -23°C(-9.4°F) • Engine speed > 450rpm • TM output speed > 300rpm • TM Input speed * Orpm • Current gear= 2nd • Gear shifting is completed • No PRNDL fail • No error in speed sensors 	
Threshold value	<ul style="list-style-type: none"> • Measured input speed - calculated input speed > 200 rpm 	
Diagnostic Time	<ul style="list-style-type: none"> • More than 1sec 	
Fail Safe	<ul style="list-style-type: none"> • Locked into 3 rd gear. 	

SIGNAL WAVEFORM EF3CB309

Tin

" No Tr k

1.

FIG.1)

A: INPUT SPEED SENSOR
B : OUTPUT SPEED SENSOR

MONITOR SCANTOOL DATA E8715A46

1. Connect scantool to data link connector(DLC).
2. Engine "ON".
3. Monitor the "ENGINE SPEED, INPUT SPEED SENSOR, OUTPUT SPEED SENSOR, GEAR POSITION" parameter on the scantool.
4. Perform the "STALL TEST" with gear position "2".

Specification : 2700-2900 engine rpm

1.2 CURRENT DATA

CRK POSITION SNSB	231B rpn
INPUT SPEED SNSR	B rpn
OUTPUT SPEED SNSH	B rpn J
SHIFT POSITION	
THROTTLE P. SENSOB	3&5 %
FLUID TEMP. SENSOB	B8 °C
VEHICLE SPEED	
LftRSU DUTV	100.0%

FIK SCRN FULL PABT GRPH HELP

OPERATING ELEMENT OF EACH SHIFTING RANGE

Range	UD clutch	OD clutch	2ND brake	LR brake	REV clutch	RED clutch	DIR clutch	owe	OWC1	
P	-	-	-	0	-	0	-	-	-	
R	-	-	-	0	0	0	-	-	-	
N	-	-	-	0	-	0	-	-	-	
D	1st	0	-	-	0	-	0	-	0	0
	2nd	0	-	0	-	-	0	-	0	-
	3rd	0	0	-	-	-	0	-	0	-
	4th	-	0	0	-	-	0	-	0	-
	5th	-	0	0	-	-	-	0	-	-

- UD/C : Underdrive clutch
- OD/C : Overdrive clutch
- 2ND/B : 2ND brake
- LR/B : Low & Reverse brake
- REV/C: Reverse clutch
- RED/B: Reduction brake
- DIR/C: Direct clutch
- OWC : One way clutch for sub gear shifting
- OWC1 : One way clutch for main gear shifting

Stall test procedure in D2 and reason

Procedure

1. Warm up the engine
2. After positioning the select lever in "D", depress the foot brake pedal fully after that, depress the accelerator pedal to the maximum

* The slippage of 1st gear operating parts can be detected by stall test in D2

Reason for stall test

1. If there is are mechanical defaults in A/T, all slippage occurs in the torque converter.
 2. Therefore, engine revolution is output, but input and output speed revolution must be "zero" due to wheel's lock.
 3. If 2nd brake system(2nd gear operating part) has faults, input speed revolution will be out of specification.
 4. If wheels pin occurs, the applied brake force is not adequate. Retry using more brake force.
5. Is "STALL TEST " within specification?

YES

- Go to "Signal circuit inspection" procedure.

NO

- Go to "Component inspection" procedure.

A CAUTION

- Do not let anybody stand in front of or behind the vehicle while this test is being carried out.
- Check the A/T fluid level and temperature and the engine coolant temperature.
- Fluid level: At the hot mark on the oil level gauge.
- Fluid temperature : 80–100° C (176°F- 212°F).
- Engine coolant temperature : 80–100° C (176°F- 212°F).

- Check both rear wheel (left and right).
- # Pull the parking brake lever on with the brake pedal fully depressed.
- The throttle should not be left fully open for more than eight second.
- # If carrying out the stall test two or more time, move the select lever to the "N" position and run the engine at 1,000 rpm to let the A/T fluid cool down before carrying out subsequent.

SIGNAL CIRCUIT INSPECTION E4F1,,1F

1. Connect Scantool.
2. Engine "ON".
3. Monitor the "INPUT & OUTPUT SPEED SENSOR" parameter on the scantool.
4. Accelerate the Engine speed until about 2000 rpm in the 2nd gear.

Specification : INPUT SPEED - (OUTPUT SPEED * GEAR RATIO) < 200 RPM

1.2 CURRENT DATA

ENGINE RPM	2188 rpn
INPUT SPEED	2056 rpn
OUTPUT SPEED	1352 rpn
SHIFT POSITION	2 GEAR
SELECT LEVER SU.	2
HI/UEC MODE	MODE D
VEHICLE SPEED	47 MPH
THROTTLE P. SENSOR	13.7 %

FIX SCEN FULL PART GEPH HELP

5. Are "INPUT & OUTPUT SPEED SENSOR" within specifications?

- Go to "Component inspection" procedure.

NO

- Check for electrical noise of circuit in INPUT & OUTPUT SPEED SENSOR or replace INPUT & OUTPUT SPEED SENSOR. Repair as necessary and go to "Verification vehicle repair" procedure.

COMPONENT INSPECTION E7D830FB

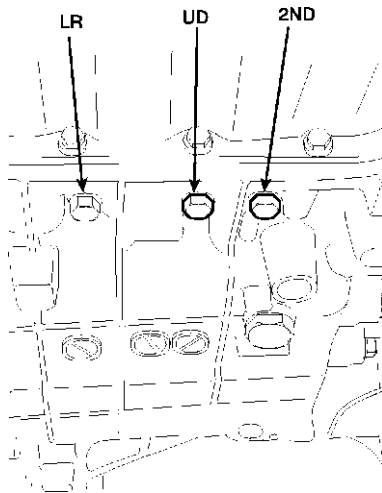

1. Connect oil pressure gauge to "UD" and "2nd" ports.
2. Engine "ON".
3. Drive a car with gear position 2 in "SPORTS MODE".
4. Compare it with reference data as below.

Specification : shown below

*1 Each case of increasing and decreasing speed.

* 2 Only for 5 speed AT.

Manual valve position	VFS current [mA]	RPM	Operation (Duty rate %)						Oil pressure MPa {kgf/cm ² }	
			LR	2ND	UD	OD	DCC	RED* ²	UD CLUTCH	LR BRAKE
D	200	2500	0	100	0	100	0	0	1.03±0.02 {10.5±0.2}	1.03±0.02 {10.5±0.2}
			100	0	0	100	0	0	1.03±0.02 {10.5±0.2}	-
R	250		0	100	100	100	0	0	-	1.55±0.25 {15.8±2.5}

Manual valve position (Oil pressure)	VFS current [mA]	RPM	Operation (Duty rate %)						Oil pressure MPa {kgf/cm ² }		
			LR	2ND	UD	OD	DCC	RED* ²	4000	1500 (Decreasing)	600 (Decreasing)
D (LR)	200	600— 4500↔ 600	0	100	0	100	0	0	MAX. 1.11 {MAX. 11.3}	-	MIN. 0.55 {MIN. 5.6}
D(UD)			0	100	0	100	0	0	MAX. 1.11 {MAX. 11.3}	-	MIN. 0.55 {MIN. 5.6}
D(UD)			100	0	0	100	0	0	MAX. 1.11 {MAX. 11.3}	-	MIN. 0.55 {MIN. 5.6}
R (LR)	250		0	100	100	100	0	0	MAX. 1.96 {MAX. 20.0}	MIN. 1.14* ¹ {MIN. 11.6}	MIN. 0.55* ¹ {MIN. 5.6}

Manual valve position (Oil pressure)	VFS current [mA]	RPM	Operation (Duty rate %)						Oil pressure MPa {kgf/cm ² }		
			LR	2ND	UD	OD	DCC	RED* ²	VFS current 200mA	VFS current: 600mA	VFS current: 1100mA
D (UD)	200↔ 1100— 200	2500	100	100	0	0	100	0	1.03±0.02 {10.5±0.2}	0.69±0.03 {7.0±0.3}	0.36±0.03 {3.7±0.3}

Manual valve position	VFS current [mA]	RPM	Operation (Duty rate %)						ELEMENT	P (MPa)
			LR	2ND	UD	OD	DCC	RED*2		
D	200	2500	0	100	0	100	0	0	LR	1.03±0.02
			60	T	T	T	T	T		0.45±0.04
			75	T	T	T	T	T		0.19±0.04
			100	T	T	T	T	T		0
			100	0	0	100	T	0	2ND	1.03±0.02
			T	60	T	T	T	T		0.50±0.05
			T	75	T	T	T	T		0.20±0.05
			T	100	T	T	T	T		0
			100	100	0	0	T	0	OD	1.02±0.02
			T	T	T	60	T	T		0.46±0.04
			T	T	T	75	T	T		0.19±0.04
			T	T	T	100	T	T		0
			100	100	0	0	T	0	UD	1.03±0.02
			T	T	60	T	T	T		0.44±0.05
			T	T	75	T	T	T		0.18±0.04
			T	T	100	T	T	T		0
			100	0	100	0	T	0T	RED	1.03±0.02
			T	T	T	T	T	60		0.49±0.04
			T	T	T	T	T	75		0.24±0.04
			T	T	T	T	T	100		0
			100T	0	100	0	T	100	DIR	0
			75	T	T	T	T	T		0.25±0.04
			60	T	T	T	T	T		0.51±0.04
			0	T	T	T	T	T		1.03±0.02

Each case of increasing (0—'100%) and decreasing (100—'0%) of duty rate to be satisfied.(Except the mark •)

Manual valve position (Oil pressure)	VFS current [mA]	RPM	Operation (Duty rate %)						Damper Apply Pressure [^] (MPa)	Damper Release Pressure (MPa)
			LR	2ND	UD	OD	DCC	RED* ²		
D	200	2500	100	100	0	0	0	0	0.25-0.45	0.50-0.70
			T	T	T	T	50	T	0.20-0.45	0
			T	T	T	T	100	T	0.96-1.04	0
	900		100	100	0	0	0	0	0.12-0.22	0.25-0.45
			T	T	T	T	100	T	MIN. 0.29	0

[^] Each case of increasing and decreasing of DCC solenoid duty rate to be satisfied.

• The values are subject to change according to vehicle model or condition.

5. Is oil pressure value within specification?

YES

• Repair AUTO TRANSAXLE(Clutch or brake) as necessary and go to "Verification vehicle repair" procedure.

NO

• Replace AUTO TRANSAXLE (BODY CONTROL VALVE faulty) as necessary and go to "Verification vehicle repair " procedure.

VERIFICATION OF VEHICLE REPAIR EOBCXMSS

Refer to DTC P0731.

DTC P0733 GEAR 3 INCORRECT RATIO

COMPONENT LOCATION E689ABCE

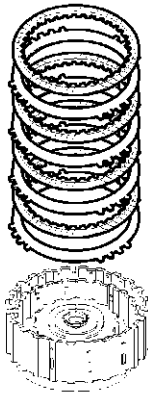

OD clutch

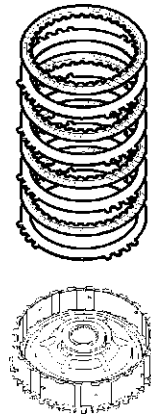

UD clutch

EKRF709A

GENERAL DESCRIPTION ED66CF30

The input shaft speed in gear 3 range should be the similar to the value that is what the gear 3 ratio and the output shaft speed are multiplied. For example, if the output shaft speed is 1,000 rpm and the gear 3 ratio is 1.421, the input shaft speed will be about 1,421 rpm.

DTC DESCRIPTION EF7D2E95

This code is displayed if the input shaft speed does not conform with the value which is what the output shaft speed and the gear 3 ratio are multiplied. This is most likely caused by a mechanical defect of adherence of control valves or a breakdown of solenoid controlled valves etc. than a electrical defect.

DTC DETECTING CONDITION EBD63CAD

Item	Detecting Condition & Fail Safe	Possible cause
DTC Strategy	<ul style="list-style-type: none"> • 3rd gear incorrect ratio 	<ul style="list-style-type: none"> • Faulty Input speed sensor • Faulty output speed sensor • Faulty UD clutch or OD clutch
Enable Conditions	<ul style="list-style-type: none"> • Engine state=Run • Battery Voltage > 11V and < 16 V • TM oil temperature > -23°C(-9.4°F) • Engine speed > 450rpm • TM output speed > 300rpm • TM Input speeds Orpm • Current gear=3rd • Gear shifting is completed • No PRNDL fail • No error in speed sensors 	
Threshold value	<ul style="list-style-type: none"> • Measured input speed - calculated input speed > 200 rpm 	
Diagnostic Time	<ul style="list-style-type: none"> • More than 1sec 	
Fail Safe	<ul style="list-style-type: none"> • Locked into 3rd gear. 	

SIGNAL WAVEFORM E2C21893

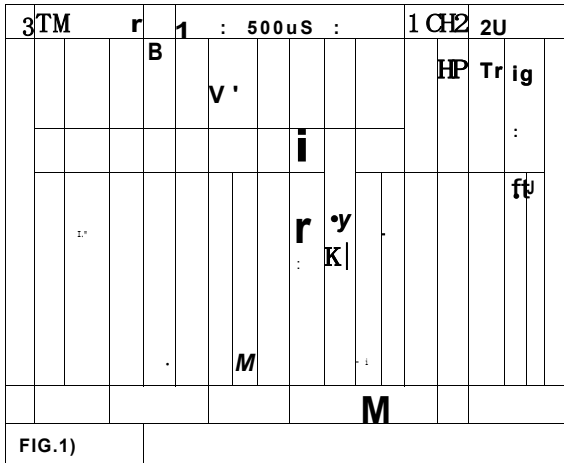

A : INPUT SPEED SENSOR
 B : OUTPUT SPEED SENSOR

EKRF709B

MONITOR SCANTOOL DATA EBFEBOEA

1. Connect scantool to data link connector(DLC).
2. Engine "ON".
3. Monitor the "ENGINE SPEED, INPUT SPEED SENSOR, OUTPUT SPEED SENSOR, GEAR POSITION" parameter on the scantool.
4. Disconnect the solenoid valve connector and perform the "STALL TEST".

Specification : 2700-2900 engine rpm

i . 2 CUBBENT DATA

```

CEK POSITION SNSE      2335  rpn
INPUT SPEED SNSB      0    rpn
OUTPUT SPEED SNSB     0    rpn
SHIFT POSITION
THROTTLE P. SENSOR    39. b %
FLUID TENP. SENSOR    -40  °C
VEHICLE SPEED         0    Kn/h
LfIRSU DUTV          0.0  %
    
```

FIK SCBN FULL PABT GRPH HELP

ELQE036A

OPERATING ELEMENT OF EACH SHIFTING RANGE

Range	UD clutch	OD clutch	2ND brake	LR brake	REV clutch	RED clutch	DIR clutch	owe	OWC1	
P	-	-	-	0	-	0	-	-	-	
R	-	-	-	0	0	0	-	-	-	
N	-	-	-	0	-	0	-	-	-	
D	1st	0	-	-	0	-	0	-	0	0
	2nd	0	-	0	-	-	0	-	0	-
	3rd	0	0	-	-	-	0	-	0	-
	4th	-	0	0	-	-	0	-	0	-
	5th	-	0	0	-	-	-	0	-	-

- UD/C : Underdrive clutch
- OD/C : Overdrive clutch
- 2ND/B : 2ND brake
- LR/B : Low & Reverse brake
- REV/C: Reverse clutch
- RED/B: Reduction brake
- DIR/C: Direct clutch
- OWC : One way clutch for sub gear shifting
- OWC1 : One way clutch for main gear shifting

Stall test procedure in D3 and reason

Procedure

1. Warm up the engine
2. Set 3rd gear hold by disconnecting the solenoid valve connector. Fully depress the brake pedal, then place the transaxle gear lever into "D" range. Press and hold the accelerator pedal to the floor for no more than eight seconds while observing the engine, input speed, and output speed RPM values.

* The slippage of 3rd gear operating parts can be detected by stall test in D3.

Reason for stall test

1. If there are no mechanical defaults in A/T, all slippage occurs in torque converter.
 2. Therefore, engine revolution is output, but input and output speed revolution must be "zero" due to wheel's lock.
 3. If OD clutch system(3rd gear operating part) has faults, input speed revolution will be out of specification.
 4. If output speed revolution is output. It means that the foot brake force is not applied fully. Retesting using greater braking force is required.
5. Is "STALL TEST " within specification?

YES

- Go to "Signal circuit inspection" procedure.

NO

- Go to "Component inspection" procedure.

A CAUTION

- Do not let anybody stand in front of or behind the vehicle while this test is being carried out.
- Check the A/T fluid level and temperature and the engine coolant temperature.
 - Fluid level: At the hot mark on the oil level gauge.
 - Fluid temperature : 80-100° C (176°F- 212°F).
 - Engine coolant temperature : 80-100° C (176°F- 212°F).
- Check both rear wheel (left and right).
- # Pull the parking brake lever on with the brake pedal fully depressed.
- The throttle should not be left fully open for more than eight seconds.
- # If carrying out the stall test two or more times, move the select lever to the "N" position and run the engine at 1,000 rpm to let the A/T fluid cool down before carrying out subsequent tests.

SIGNAL CIRCUIT INSPECTION EDD9EFE2

1. Connect Scantool.
2. Engine "ON".
3. Monitor the "INPUT & OUTPUT SPEED SENSOR" parameter on the scantool.
4. Accelerate the Engine speed until about 2000 rpm in the 3rd gear.

Specification : INPUT SPEED - (OUTPUT SPEED * GEAR RATIO) < 200 RPM

1. 2 CUB REN I DATA

ENGINE RPM	2116 rpm
INPUT SPEED	2856 rpm
OUTPUT SPEED	2654 rpm
SHIFT POSITION	3 GEAR
SELECT LEVER SU.	3
HUEC MODE	MODE F
VEHICLE SPEED	47 MPH
THROTTLE P. SENSOR	14.1 %

FIK SCEN FULL PART GRAPH HELP

ELQE037A

5. Are "INPUT & OUTPUT SPEED SENSOR" within specifications?

YES

- Go to "Component inspection" procedure.

NO

- Check for electrical noise of circuit in INPUT & OUTPUT SPEED SENSOR or replace INPUT & OUTPUT SPEED SENSOR. Repair as necessary and go to "Verification & repair" procedure.

COMPONENT INSPECTION EAE620AD

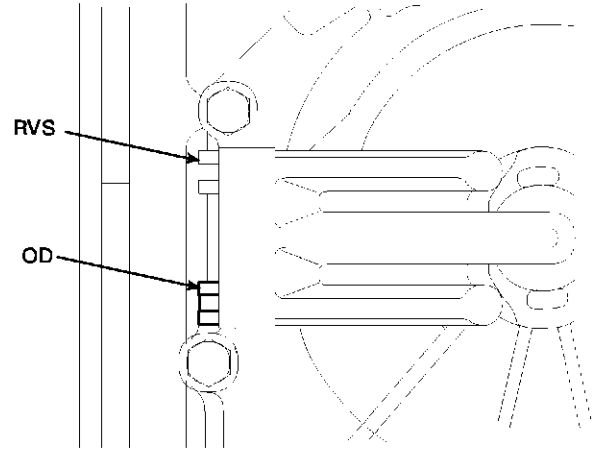
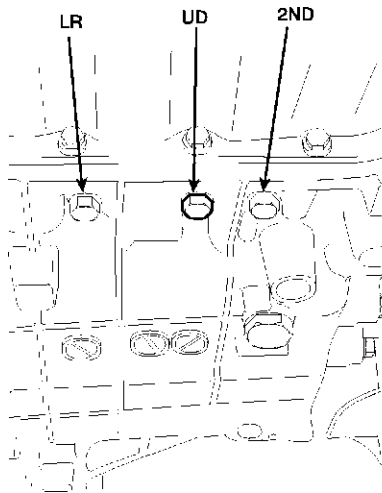

1. Connect Oil pressure gauge to "UD" and "OD" ports.
2. Engine "ON".
3. Drive a car with gear position 3 in "SPORTS MODE".
4. Compare it with reference data as below.

Specification : shown below

*1 Each case of increasing and decreasing speed.

* 2 Only for 5 speed AT.

Manual valve position	VFS current [mA]	RPM	Operation (Duty rate %)						Oil pressure MPa {kgf/cm ² }	
			LR	2ND	UD	OD	DCC	RED* ²	UD CLUTCH	LR BRAKE
D	200	2500	0	100	0	100	0	0	1.03±0.02 {10.5±0.2}	1.03±0.02 {10.5±0.2}
			100	0	0	100	0	0	1.03±0.02 {10.5±0.2}	-
R	250		0	100	100	100	0	0	-	1.55±0.25 {15.8±2.5}

Manual valve position (Oil pressure)	VFS current [mA]	RPM	Operation (Duty rate %)						Oil pressure MPa {kgf/cm ² }		
			LR	2ND	UD	OD	DCC	RED* ²	4000	1500 (Decreasing)	600 (Decreasing)
D (LR)	200	600— 4500↷ 600	0	100	0	100	0	0	MAX. 1.11 {MAX. 11.3}	-	MIN. 0.55 {MIN. 5.6}
D(UD)			0	100	0	100	0	0	MAX. 1.11 {MAX. 11.3}	-	MIN. 0.55 {MIN. 5.6}
D(UD)			100	0	0	100	0	0	MAX. 1.11 {MAX. 11.3}	-	MIN. 0.55 {MIN. 5.6}
R (LR)			250	0	100	100	100	0	0	MAX. 1.96 {MAX. 20.0}	MIN. 1.14* ¹ {MIN. 11.6}

Manual valve position (Oil pressure)	VFS current [mA]	RPM	Operation (Duty rate %)						Oil pressure MPa {kgf/cm ² }		
			LR	2ND	UD	OD	DCC	RED* ²	VFS current 200mA	VFS current: 600mA	VFS current: 1100mA
D (UD)	200↷ 1100— 200	2500	100	100	0	0	100	0	1.03±0.02 {10.5±0.2}	0.69±0.03 {7.0±0.3}	0.36±0.03 {3.7±0.3}

Manual valve position	VFS current [mA]	RPM	Operation (Duty rate %)						ELEMENT	P (MPa)
			LR	2ND	UD	OD	DCC	RED*2		
D	200	2500	0	100	0	100	0	0	LR	1.03±0.02
			60	T	T	T	T	T		0.45±0.04
			75	T	T	T	T	T		0.19±0.04
			100	T	T	T	T	T		0
			100	0	0	100	T	0	2ND	1.03±0.02
			T	60	T	T	T	T		0.50±0.05
			T	75	T	T	T	T		0.20±0.05
			T	100	T	T	T	T		0
			100	100	0	0	T	0	OD	1.02±0.02
			T	T	T	60	T	T		0.46±0.04
			T	T	T	75	T	T		0.19±0.04
			T	T	T	100	T	T		0
			100	100	0	0	T	0	UD	1.03±0.02
			T	T	60	T	T	T		0.44±0.05
			T	T	75	T	T	T		0.18±0.04
			T	T	100	T	T	T		0
			100	0	100	0	T	0T	RED	1.03±0.02
			T	T	T	T	T	60		0.49±0.04
			T	T	T	T	T	75		0.24±0.04
			T	T	T	T	T	100		0
			100T	0	100	0	T	100	DIR	0
			75	T	T	T	T	T		0.25±0.04
			60	T	T	T	T	T		0.51±0.04
			0	T	T	T	T	T		1.03±0.02

Each case of increasing (0—'100%) and decreasing (100—'0%) of duty rate to be satisfied.(Except the mark •)

Manual valve position (Oil pressure)	VFS current [mA]	RPM	Operation (Duty rate %)						Damper Apply Pressure [^] (MPa)	Damper Release Pressure (MPa)
			LR	2ND	UD	OD	DCC	RED* ²		
D	200	2500	100	100	0	0	0	0	0.25-0.45	0.50-0.70
			T	T	T	T	50	T	0.20-0.45	0
			T	T	T	T	100	T	0.96-1.04	0
	900		100	100	0	0	0	0	0.12-0.22	0.25-0.45
			T	T	T	T	100	T	MIN. 0.29	0

[^] Each case of increasing and decreasing of DCC solenoid duty rate to be satisfied.

• The values are subject to change according to vehicle model or condition.

5. Is oil pressure value within specification?

YES

• Repair AUTO TRANSAXLE(Clutch or brake) as necessary and go to "Verification vehicle repair" procedure.

NO

• Replace AUTO TRANSAXLE (BODY CONTROL VALVE faulty) as necessary and go to "Verification vehicle repair " procedure.

VERIFICATION OF VEHICLE REPAIR EBCCBESE

Refer to DTC P0731.

DTC P0734 GEAR 4 INCORRECT RATIO

COMPONENT LOCATION E1FBE479

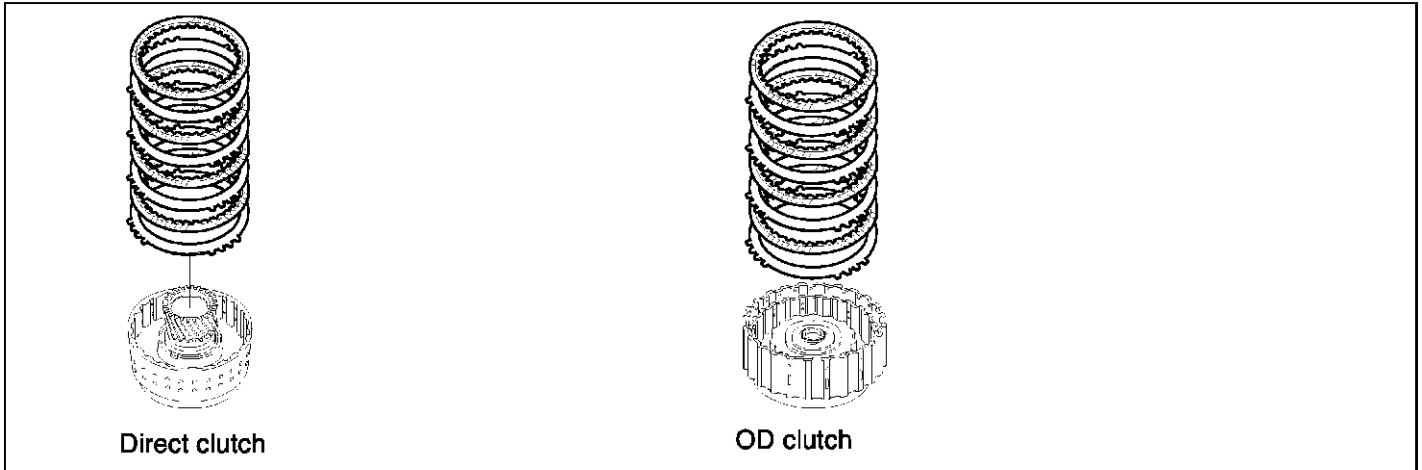

EKRF711A

GENERAL DESCRIPTION E1BDSCB0

The input shaft speed in gear 4 range should be similar to the value that is what the gear 4 ratio and the output shaft speed are multiplied. For example, if the output shaft speed is 1,000 rpm and the gear 4 ratio is 1.034, the input shaft speed may be about 1,034 rpm.

DTC DESCRIPTION E77B8CD7

This code is displayed if the input shaft speed does not conform with the value which is what the output shaft speed and the gear 4 ratio are multiplied. This is most likely caused by a mechanical defect of adherence of control valves or a breakdown of solenoid controlled valves etc. than a electrical defect.

DTC DETECTING CONDITION EA53AA79

Item	Detecting Condition & Fail Safe	Possible cause
DTC Strategy	<ul style="list-style-type: none"> • 4th gear incorrect ratio 	<ul style="list-style-type: none"> • Faulty input speed sensor • Faulty output speed sensor • Faulty direct clutch or OD clutch
Enable Conditions	<ul style="list-style-type: none"> • Engine state=Run • Battery Voltage > 11V and < 16 V • TM oil temperature > -23°C(-9.4°F) • Engine speed > 450rpm • TM output speed > 300rpm • TM Input speed* Orpm • Current gear=4th • Gear shifting is completed • No PRNDL fail • No error in speed sensors 	
Threshold value	<ul style="list-style-type: none"> • Measured input speed - calculated input speed > 200 rpm 	
Diagnostic Time	<ul style="list-style-type: none"> • More than 1sec 	
Fail Safe	<ul style="list-style-type: none"> • Locked into 3rd gear. 	

SIGNAL WAVEFORM EF46CCBC

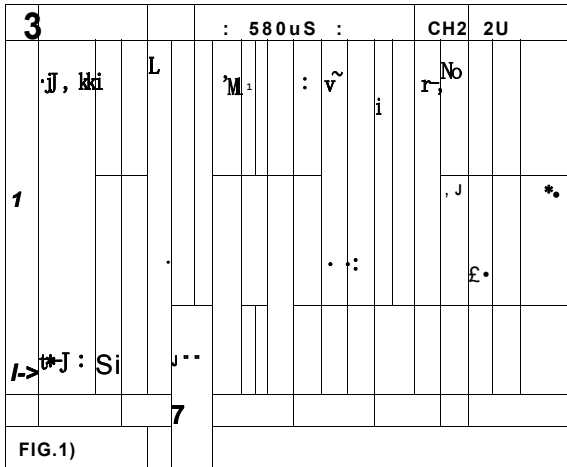

A : INPUT SPEED SENSOR
B : OUTPUT SPEED SENSOR

EKRF710B

MONITOR SCANTOOL DATA E4EE52C0

*K It is difficult to "STALL TEST" in 4th gear, therefore Go to "W/Harness Inspection" procedure.

OPERATING ELEMENT OF EACH SHIFTING RANGE

Range	UD clutch	OD clutch	2ND brake	LR brake	REV clutch	RED clutch	DIR clutch	owe	OWC1
P	-	-	-	0	-	0	-	-	-
R	-	-	-	0	0	0	-	-	-
N	-	-	-	0	-	0	-	-	-
D	1st	0	-	0	-	0	-	0	0
	2nd	0	-	0	-	0	-	0	-
	3rd	0	0	-	-	0	-	0	-
	4th	-	0	0	-	0	-	0	-
	5th	-	0	0	-	-	-	0	-

UD/C : Underdrive clutch
 OD/C : Overdrive clutch
 2ND/B : 2ND brake
 LR/B : Low & Reverse brake
 REV/C: Reverse clutch
 RED/B: Reduction brake
 DIR/C: Direct clutch
 OWC : One way clutch for sub gear shifting
 OWC1 : One way clutch for main gear shifting

SIGNAL CIRCUIT INSPECTION E5EC4F3C

1. Connect Scantool.
2. Engine "ON".
3. Monitor the "INPUT & OUTPUT SPEED SENSOR" parameter on the scantool.
4. Accelerate the Engine speed until about 2000 rpm in the 4th gear while driving the vehicle on a level road.

Specification : INPUT SPEED - (OUTPUT SPEED * GEAR RATIO) ^ 200 RPM

1. 2 CURRENT DATA		
	ENGINE RPM	2133 rpn
" I	INPUT SPEED	2856 rpn
*	OUTPUT SPEED	2911 rpn
	SHIFT POSITION	4 GEAR
a	SELECT LEVEE SU.	D
	2ND SOLENOID DUTV	0.0
	OD SOLENOID DUT¥	0.0 %
	OIL TEMPERATURE	156 °F

FIK SCRN FULL PART GBPH HELP

ELQE038A

5. Does "INPUT & OUTPUT SPEED SENSOR" within specifications?

YES

- Go to "Component inspection" procedure.

NO

- Check for electrical noise of circuit in INPUT & OUTPUT SPEED SENSOR or Replace INPUT & OUTPUT SPEED SENSOR. Repair as necessary and Go to "Verification vehicle repair" procedure.

COMPONENT INSPECTION E8A99606

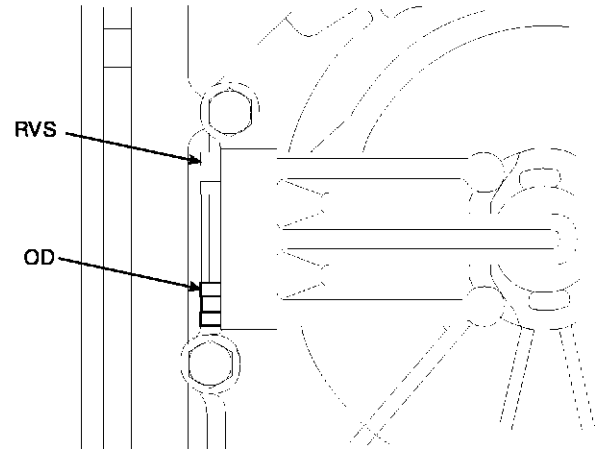
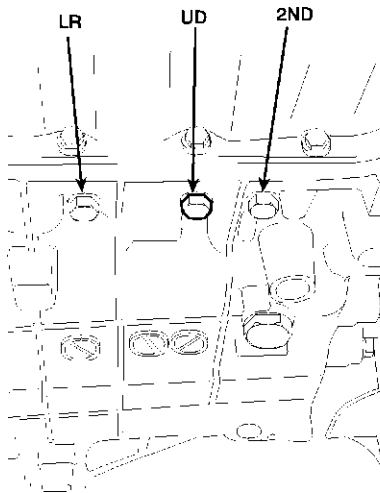

KKCF209D

1. Connect oil pressure gauge to "UD" and "OD" ports.
2. Engine "ON".
3. Drive a car with gear position "4".
4. Compare it with reference data as below.

Specification : shown below

*1 Each case of increasing and decreasing speed.

* 2 Only for 5 speed A/T.

Manual valve position	VFS current [mA]	RPM	Operation (Duty rate %)						Oil pressure MPa {kgf/cm ² }	
			LR	2ND	UD	OD	DCC	RED* ²	UD CLUTCH	LR BRAKE
D	200	2500	0	100	0	100	0	0	1.03±0.02 {10.5±0.2}	1.03±0.02 {10.5±0.2}
			100	0	0	100	0	0	1.03±0.02 {10.5±0.2}	-
R	250		0	100	100	100	0	0	-	1.55±0.25 {15.8±2.5}

Manual valve position (Oil pressure)	VFS current [mA]	RPM	Operation (Duty rate %)						Oil pressure MPa {kgf/cm ² }		
			LR	2ND	UD	OD	DCC	RED* ²	4000	1500 (Decreasing)	600 (Decreasing)
D (LR)	200	600— 4500— 600	0	100	0	100	0	0	MAX. 1.11 {MAX. 11.3}	-	MIN. 0.55 {MIN. 5.6}
D(UD)			0	100	0	100	0	0	MAX. 1.11 {MAX. 11.3}	-	MIN. 0.55 {MIN. 5.6}
D(UD)			100	0	0	100	0	0	MAX. 1.11 {MAX. 11.3}	-	MIN. 0.55 {MIN. 5.6}
R (LR)	250		0	100	100	100	0	0	MAX. 1.96 {MAX. 20.0}	MIN. 1.14* ¹ {MIN. 11.6}	MIN. 0.55* ¹ {MIN. 5.6}

Manual valve position (Oil pressure)	VFS current [mA]	RPM	Operation (Duty rate %)						Oil pressure MPa {kgf/cm ² }		
			LR	2ND	UD	OD	DCC	RED* ²	VFS current 200mA	VFS current: 600mA	VFS current: 1100mA
D (UD)	200— 1100— 200	2500	100	100	0	0	100	0	1.03±0.02 {10.5±0.2}	0.69±0.03 {7.0±0.3}	0.36±0.03 {3.7±0.3}

Manual valve position	VFS current [mA]	RPM	Operation (Duty rate %)					ELEMENT	P (MPa)	
			LR	2ND	UD	OD	DCC			RED*2
D	200	2500	0	100	0	100	0	0	LR	1.03±0.02
			60	⊥	⊥	⊥	⊥	⊥		0.45±0.04
			75	⊥	⊥	⊥	⊥	⊥		0.19±0.04
			100	⊥	⊥	⊥	⊥	⊥		0
			100	0	0	100	⊥	0	2ND	1.03±0.02
			⊥	60	⊥	⊥	⊥	⊥		0.50±0.05
			⊥	75	⊥	⊥	⊥	⊥		0.20±0.05
			⊥	100	⊥	⊥	⊥	⊥		0
			100	100	0	0	⊥	0	OD	1.02±0.02
			⊥	⊥	⊥	60	⊥	⊥		0.46±0.04
			⊥	⊥	⊥	75	⊥	⊥		0.19±0.04
			⊥	⊥	⊥	100	⊥	⊥		0
			100	100	0	0	⊥	0	UD	1.03±0.02
			⊥	⊥	60	⊥	⊥	⊥		0.44±0.05
			⊥	⊥	75	⊥	⊥	⊥		0.18±0.04
			⊥	⊥	100	⊥	⊥	⊥		0
			100	0	100	0	⊥	0T	RED	1.03±0.02
			⊥	⊥	⊥	⊥	⊥	60		0.49±0.04
			⊥	⊥	⊥	⊥	⊥	75		0.24±0.04
			⊥	⊥	⊥	⊥	⊥	100		0
100T	0	100	0	⊥	100	DIR	0			
75	⊥	⊥	⊥	⊥	⊥		0.25±0.04			
60	⊥	⊥	⊥	⊥	⊥		0.51±0.04			
0	⊥	⊥	⊥	⊥	⊥		1.03±0.02			

Each case of increasing (0-M00%) and decreasing (100—'0%) of duty rate to be satisfied.(Except the mark ⊥)

Manual valve position (Oil pressure)	VFS current [mA]	RPM	Operation (Duty rate %)						Damper Apply Pressure % (MPa)	Damper Release Pressure (MPa)
			LR	2ND	UD	OD	DCC	RED*2		
D	200	2500	100	100	0	0	0	0	0.25-0.45	0.50-0.70
			T	T	T	T	50	T	0.20-0.45	0
			T	T	T	T	100	T	0.96-1.04	0
	900		100	100	0	0	0	0	0.12-0.22	0.25-0.45
			T	T	T	T	100	T	MIN. 0.29	0

^ Each case of increasing and decreasing of DCC solenoid duty rate to be satisfied.

• The values are subject to change according to vehicle model or condition.

5. Is oil pressure value within specification?

YES

• Repair AUTO TRANSAXLE(Clutch or brake) as necessary and go to "Verification vehicle repair" procedure.

NO

• Replace AUTO TRANSAXLE (BODY CONTROL VALVE faulty) as necessary and go to "Verification vehicle repair " procedure.

VERIFICATION OF VEHICLE REPAIR E,BCFFF,

Refer to DTC P0731.

DTC P0735 GEAR 5 INCORRECT RATIO

COMPONENT LOCATION E6FCF649

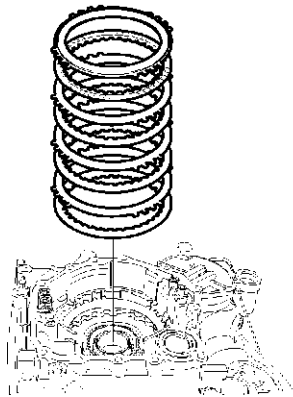

2ND brake

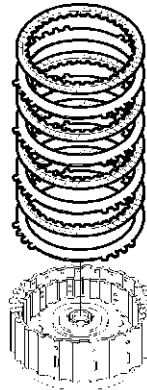

OD clutch

EKRF710A

GENERAL DESCRIPTION EECE25D9

The input shaft speed in gear 5 range should be the similar to the value that is what the gear 5 ratio and the output shaft speed are multiplied. For example, if the output shaft speed is 1,000 rpm and the gear 5 ratio is 0.728, the input shaft speed may be about 728 rpm.

DTC DESCRIPTION E0B9763A

This code is displayed if the input shaft speed does not conform with the value which is what the output shaft speed and the gear 5 ratio are multiplied. This is most likely caused by a mechanical defect of adherence of control valves or a breakdown of solenoid controlled valves etc. than a electrical defect.

DTC DETECTING CONDITION ECA59778

Item	Detecting Condition & Fail Safe	Possible cause
DTC Strategy	<ul style="list-style-type: none"> • 5th gear incorrect ratio 	<ul style="list-style-type: none"> • Faulty input speed sensor • Faulty output speed sensor • Faulty 2nd brake or OD clutch
Enable Conditions	<ul style="list-style-type: none"> • Engine state=Run • Battery Voltage > 11V and < 16 V • TM oil temperature > -23°C(-9.4°F) • Engine speed > 450rpm • TM output speed > 300rpm • TM Input speed* Orpm • Current gear=5th • Gear shifting is completed • No PRNDL fail • No error in speed sensors 	
Threshold value	<ul style="list-style-type: none"> • Measured input speed - calculated input speed > 200 rpm 	
Diagnostic Time	<ul style="list-style-type: none"> • More than 1sec 	
Fail Safe	<ul style="list-style-type: none"> • Locked into 3rd gear. 	

SIGNAL WAVEFORM EF4EBDC6

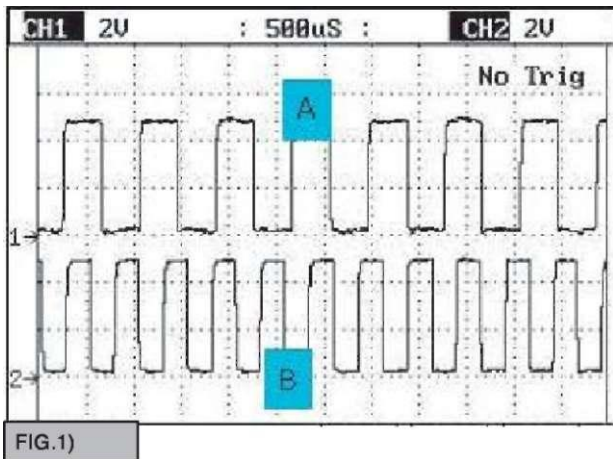

A : INPUT SPEED SENSOR
B : OUTPUT SPEED SENSOR

MONITOR SCANTOOL DATA EC488C72

*K It is difficult to "STALL TEST" in 5th gear, therefore Go to "W/Harness inspection" procedure.

OPERATING ELEMENT OF EACH SHIFTING RANGE

Range	UD clutch	OD clutch	2ND brake	LR brake	REV clutch	RED clutch	DIR clutch	owe	OWC1
P	-	-	-	0	-	0	-	-	-
R	-	-	-	0	0	0	-	-	-
N	-	-	-	0	-	0	-	-	-
D	1st	0	-	0	-	0	-	0	0
	2nd	0	-	0	-	0	-	0	-
	3rd	0	0	-	-	0	-	0	-
	4th	-	0	0	-	0	-	0	-
	5th	-	0	0	-	-	-	0	-

- UD/C : Underdrive clutch
- OD/C : Overdrive clutch
- 2ND/B : 2ND brake
- LR/B : Low & Reverse brake
- REV/C: Reverse clutch
- RED/B: Reduction brake
- DIR/C: Direct clutch
- OWC : One way clutch for sub gear shifting
- OWC1 : One way clutch for main gear shifting

SIGNAL CIRCUIT INSPECTION E.,OBCI3

1. Connect Scantool.
2. Engine "ON".
3. Monitor the "INPUT & OUTPUT SPEED SENSOR" parameter on the scantool.
4. Accelerate the Engine speed until about 2000 rpm in the 5th gear while driving the vehicle on a level road.

Specification : INPUT SPEED - (OUTPUT SPEED * GEAR RATIO) < 200 RPM

1. 2 CUBBEMT DATA		
		1
x	ENGINE RPM	2127 rpn
x	INPUT SPEED	2056 rpn
x	OUTPUT SPEED	2914 rpn
x	SHIFT POSITION	5 SEAB
x	SELECT LEUEB SU.	L
	HIOEC NODE	NODE F
	UEHICLE SPEED	22 NPH
	THBOTTLE P. SENSOB	14.1 %
		T
FIX SCBN FULL FABT GBPH HELP		

5. Are "INPUT & OUTPUT SPEED SENSOR" within specifications?

- Go to "Component inspection" procedure.
- Check for electrical noise of circuit in INPUT & OUTPUT SPEED SENSOR or Replace INPUT & OUTPUT SPEED SENSOR. Repair as necessary and Go to "Verification vehicle repair" procedure.

COMPONENT INSPECTION E37F3AC2

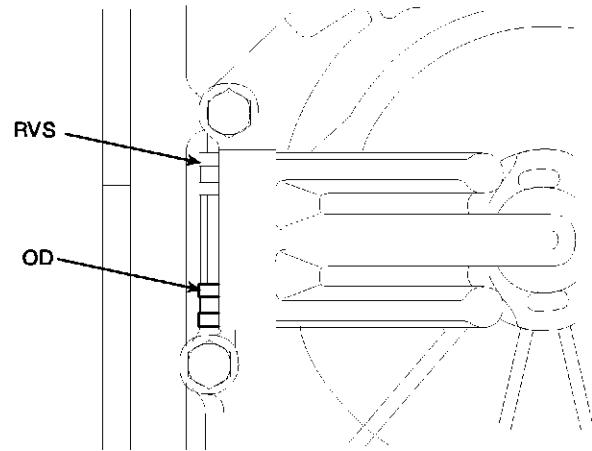
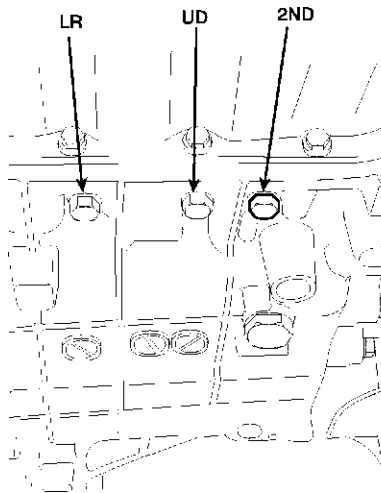

KKCF210D

1. Connect oil pressure gauge to "2nd" and "OD" ports.
2. Engine "ON".
3. Drive a car with gear position "5".
4. Compare it with reference data as below.

Specification : shown below

*1 Each case of increasing and decreasing speed.

* 2 Only for 5 speed AT.

Manual valve position	VFS current [mA]	RPM	Operation (Duty rate %)						Oil pressure MPa {kgf/cm ² }	
			LR	2ND	UD	OD	DCC	RED* ²	UD CLUTCH	LR BRAKE
D	200	2500	0	100	0	100	0	0	1.03±0.02 {10.5±0.2}	1.03±0.02 {10.5±0.2}
			100	0	0	100	0	0	1.03±0.02 {10.5±0.2}	-
R	250		0	100	100	100	0	0	-	1.55±0.25 {15.8±2.5}

Manual valve position (Oil pressure)	VFS current [mA]	RPM	Operation (Duty rate %)						Oil pressure MPa {kgf/cm ² }		
			LR	2ND	UD	OD	DCC	RED* ²	4000	1500 (Decreasing)	600 (Decreasing)
D (LR)	200	600— 4500↗ 600	0	100	0	100	0	0	MAX. 1.11 {MAX. 11.3}	-	MIN. 0.55 {MIN. 5.6}
D(UD)			0	100	0	100	0	0	MAX. 1.11 {MAX. 11.3}	-	MIN. 0.55 {MIN. 5.6}
D(UD)			100	0	0	100	0	0	MAX. 1.11 {MAX. 11.3}	-	MIN. 0.55 {MIN. 5.6}
R (LR)	250		0	100	100	100	0	0	MAX. 1.96 {MAX. 20.0}	MIN. 1.14* ¹ {MIN. 11.6}	MIN. 0.55* ¹ {MIN. 5.6}

Manual valve position (Oil pressure)	VFS current [mA]	RPM	Operation (Duty rate %)						Oil pressure MPa {kgf/cm ² }		
			LR	2ND	UD	OD	DCC	RED* ²	VFS current 200mA	VFS current: 600mA	VFS current: 1100mA
D (UD)	200↗ 1100— 200	2500	100	100	0	0	100	0	1.03±0.02 {10.5±0.2}	0.69±0.03 {7.0±0.3}	0.36±0.03 {3.7±0.3}

Manual valve position	VFS current [mA]	RPM	Operation (Duty rate %)						ELEMENT	P (MPa)
			LR	2ND	UD	OD	DCC	RED*2		
D	200	2500	0	100	0	100	0	0	LR	1.03±0.02
			60	T	T	T	T	T		0.45±0.04
			75	T	T	T	T	T		0.19±0.04
			100	T	T	T	T	T		0
			100	0	0	100	T	0	2ND	1.03±0.02
			T	60	T	T	T	T		0.50±0.05
			T	75	T	T	T	T		0.20±0.05
			T	100	T	T	T	T		0
			100	100	0	0	T	0	OD	1.02±0.02
			T	T	T	60	T	T		0.46±0.04
			T	T	T	75	T	T		0.19±0.04
			T	T	T	100	T	T		0
			100	100	0	0	T	0	UD	1.03±0.02
			T	T	60	T	T	T		0.44±0.05
			T	T	75	T	T	T		0.18±0.04
			T	T	100	T	T	T		0
			100	0	100	0	T	0T	RED	1.03±0.02
			T	T	T	T	T	60		0.49±0.04
			T	T	T	T	T	75		0.24±0.04
			T	T	T	T	T	100		0
			100T	0	100	0	T	100	DIR	0
			75	T	T	T	T	T		0.25±0.04
			60	T	T	T	T	T		0.51±0.04
			0	T	T	T	T	T		1.03±0.02

Each case of increasing (0—'100%) and decreasing (100—'0%) of duty rate to be satisfied.(Except the mark •)

Manual valve position (Oil pressure)	VFS current [mA]	RPM	Operation (Duty rate %)						Damper Apply Pressure [^] (MPa)	Damper Release Pressure (MPa)
			LR	2ND	UD	OD	DCC	RED* ²		
D	200	2500	100	100	0	0	0	0	0.25-0.45	0.50-0.70
			T	T	T	T	50	T	0.20-0.45	0
			T	T	T	T	100	T	0.96-1.04	0
	900		100	100	0	0	0	0	0.12-0.22	0.25-0.45
			T	T	T	T	100	T	MIN. 0.29	0

[^] Each case of increasing and decreasing of DCC solenoid duty rate to be satisfied.

• The values are subject to change according to vehicle model or condition.

5. Is oil pressure value within specification?

YES

• Repair AUTO TRANSAXLE(Clutch or brake) as necessary and go to "Verification vehicle repair" procedure.

NO

• Replace AUTO TRANSAXLE (BODY CONTROL VALVE faulty) as necessary and go to "Verification vehicle repair " procedure.

VERIFICATION OF VEHICLE REPAIR

Refer to DTC P0731.

DTC P0736 REVERSE GEAR INCORRECT RATIO

COMPONENT LOCATION EAADA1A0

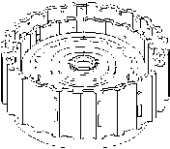
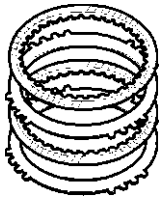

Revers clutch

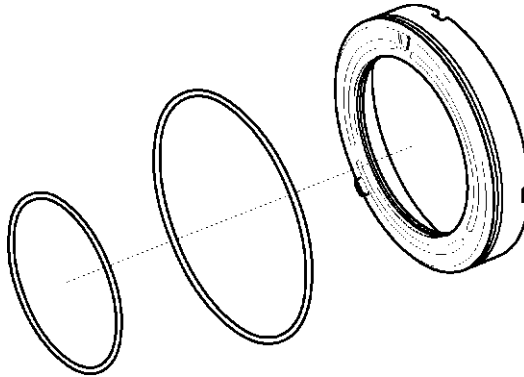

L&R brake

GENERAL DESCRIPTION E7,A,F,I,

The input shaft speed in gear reverse range should be the similar to the value that is what the gear reverse ratio and the output shaft speed are multiplied. For example, if the output shaft speed is 1,000 rpm and the gear reverse ratio is 3.808, the input shaft speed may be about 3,808 rpm.

DTC DESCRIPTION EDE97EFA

This code is displayed if the input shaft speed does not conform with the value which is what the output shaft speed and the gear reverse ratio are multiplied. This is most likely caused by a mechanical defect of adherence of control valves or a breakdown of solenoid controlled valves etc. than a electrical defect.

DTC DETECTING CONDITION ECA6DD1A

Item	Detecting Condition & Fail Safe	Possible cause
DTC Strategy	<ul style="list-style-type: none"> Reverse gear incorrect ratio 	<ul style="list-style-type: none"> Faulty input speed sensor Faulty output speed sensor Faulty RVS clutch or L/R brake
Enable Conditions	<ul style="list-style-type: none"> Engine state=Run Battery Voltage > 11V and < 16 V TM oil temperature > -23°C(-9.4°F) Engine speed > 450rpm TM output speed > 100rpm TM Input speed* Orpm Current gear=reverse Gear shifting is completed No PRNDL fail No error in speed sensors 	
Threshold value	<ul style="list-style-type: none"> Measured input speed - calculated input speed > 200 rpm 	
Diagnostic Time	<ul style="list-style-type: none"> More than 1sec 	
Fail Safe	<ul style="list-style-type: none"> Locked into 3rd gear. 	

OPERATING ELEMENT OF EACH SHIFTING RANGE

Range		UD clutch	OD clutch	2ND brake	LR brake	REV clutch	RED clutch	DIR clutch	owe	OWC1
P		-	-	-	0	-	0	-	-	-
R		-	-	-	0	0	0	-	-	-
N		-	-	-	0	-	0	-	-	-
D	1st	0	-	-	0	-	0	-	0	0
	2nd	0	-	0	-	-	0	-	0	-
	3rd	0	0	-	-	-	0	-	0	-
	4th	-	0	0	-	-	0	-	0	-
	5th	-	0	0	-	-	-	0	-	-

- UD/C : Underdrive clutch
- OD/C : Overdrive clutch
- 2ND/B : 2ND brake
- LR/B : Low & Reverse brake
- REV/C: Reverse clutch
- RED/B: Reduction brake
- DIR/C: Direct clutch
- OWC : One way clutch for sub gear shifting
- OWC1 : One way clutch for main gear shifting

Stall test procedure in Reverse and reason

Procedure

1. Warm up the engine
2. Fully depress the brake pedal, then place the transaxle gear lever into "R" range. Press and hold the accelerator pedal to the floor for no more than eight seconds while observing the engine, input speed, and output speed RPM values.

* The slippage of REVERSE clutch and L/R brake can be detected by stall test in R range.

Reason for stall test

1. If there is no mechanical defaults in A/T, all slippage occurs in the torque converter.
 2. Therefore, engine revolution is output, but input and output speed revolution must be "zero" due to wheel's lock.
 3. If reverse clutch and L/R brake system(reverse gear operating parts) has faults, input speed revolution will be out of specification.
 4. If output speed revolution is output. It means that the foot brake force is not applied fully. Remeasuring is required.
5. Is "STALL TEST " within specification?

YES

- Go to "Signal circuit inspection" procedure.

NO

- Go to "Component inspection" procedure.

CAUTION

- Do not let anybody stand in front of or behind the vehicle while this test is being carried out.
- Check the A/T fluid level and temperature and the engine coolant temperature.

Fluid level: At the hot mark on the oil level gauge.

Fluid temperature : 80~100°C (176~212°F).

Engine coolant temperature : 80~100°C (176~212°F).

- *Check both rear wheelleft and right).*
- *Pull the parking brake lever on with the brake pedal fully depressed.*
- *The throttle should not be left fully open for more than eight seconds.*
- *If carrying out the stall test two or more time, move the select lever to the "N" position and run the engine at 1,000 rpm to let the A/T fluid cool down before carrying out subsequent tests.*

SIGNAL CIRCUIT INSPECTION EF23F50A

1. Connect Scantool.
2. Engine "ON".
3. Monitor the "INPUT & OUTPUT SPEED SENSOR" parameter on the scantool.
4. Accelerate the Engine speed until about 2000 rpm in the "R" gear.

Specification : INPUT SPEED - (OUTPUT SPEED * GEAR RATIO) < 200 RPM

1. 2 CURRENT DATA		
		1
ENGINE BPH	2127 rpn	
INPUT SPEED	2056 rpn	
κ OUTPUT SPEED	828 rpn	
x SHIFT POSITION	R nEAB	
x SELECT LEVEE SU.	L	•
HIUEC NODE	NODE F	
VEHICLE SPEED	22 NPH	
THROTTLE P. SENSOB	14.1 X	
		T
FIX SCF.N FULL POST GR.HI HELP		

ELQE040A

5. Are "INPUT & OUTPUT SPEED SENSOR" within specifications?

- Go to "Component inspection" procedure.

NO

- Check for electrical noise of circuit in INPUT & OUTPUT SPEED SENSOR or replace INPUT & OUTPUT SPEED SENSOR. Repair as necessary and go to "Verification vehicle repair" procedure.

COMPONENT INSPECTION EBCE1412

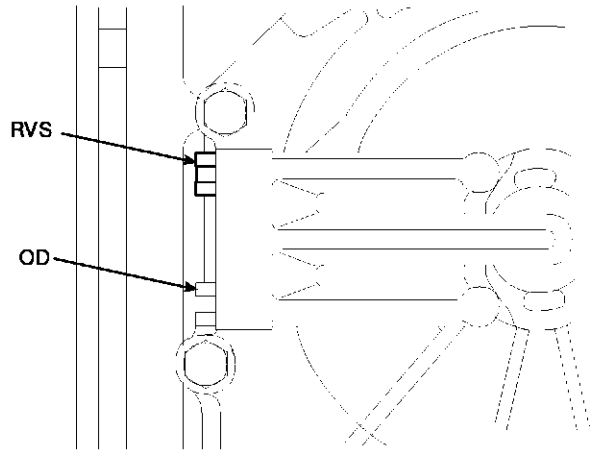
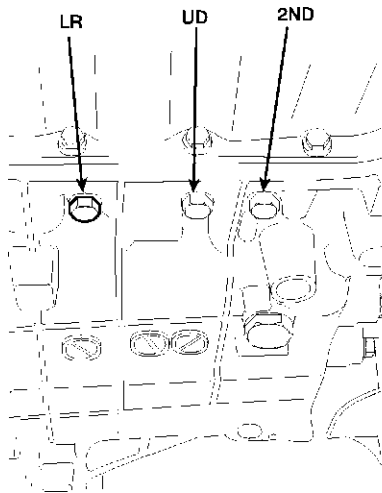

KKCF211E

1. Connect oil pressure gauge to "RVS" and "L/R" ports.
2. Engine "ON".
3. Drive a car with gear position R.
4. Compare it with reference data as below.

Specification : shown below

*1 Each case of increasing and decreasing speed.

* 2 Only for 5 speed AT.

Manual valve position	VFS current [mA]	RPM	Operation (Duty rate %)						Oil pressure MPa {kgf/cm ² }	
			LR	2ND	UD	OD	DCC	RED* ²	UD CLUTCH	LR BRAKE
D	200	2500	0	100	0	100	0	0	1.03±0.02 {10.5±0.2}	1.03±0.02 {10.5±0.2}
			100	0	0	100	0	0	1.03±0.02 {10.5±0.2}	-
R	250		0	100	100	100	0	0	-	1.55±0.25 {15.8±2.5}

Manual valve position (Oil pressure)	VFS current [mA]	RPM	Operation (Duty rate %)						Oil pressure MPa {kgf/cm ² }		
			LR	2ND	UD	OD	DCC	RED* ²	4000	1500 (Decreasing)	600 (Decreasing)
D (LR)	200	600— 4500↗ 600	0	100	0	100	0	0	MAX. 1.11 {MAX. 11.3}	-	MIN. 0.55 {MIN. 5.6}
D(UD)			0	100	0	100	0	0	MAX. 1.11 {MAX. 11.3}	-	MIN. 0.55 {MIN. 5.6}
D(UD)			100	0	0	100	0	0	MAX. 1.11 {MAX. 11.3}	-	MIN. 0.55 {MIN. 5.6}
R (LR)	250		0	100	100	100	0	0	MAX. 1.96 {MAX. 20.0}	MIN. 1.14* ¹ {MIN. 11.6}	MIN. 0.55* ¹ {MIN. 5.6}

Manual valve position (Oil pressure)	VFS current [mA]	RPM	Operation (Duty rate %)						Oil pressure MPa {kgf/cm ² }		
			LR	2ND	UD	OD	DCC	RED* ²	VFS current 200mA	VFS current: 600mA	VFS current: 1100mA
D (UD)	200↗ 1100— 200	2500	100	100	0	0	100	0	1.03±0.02 {10.5±0.2}	0.69±0.03 {7.0±0.3}	0.36±0.03 {3.7±0.3}

Manual valve position	VFS current [mA]	RPM	Operation (Duty rate %)						ELEMENT	P (MPa)
			LR	2ND	UD	OD	DCC	RED*2		
D	200	2500	0	100	0	100	0	0	LR	1.03±0.02
			60	T	T	T	T	T		0.45±0.04
			75	T	T	T	T	T		0.19±0.04
			100	T	T	T	T	T		0
			100	0	0	100	T	0	2ND	1.03±0.02
			T	60	T	T	T	T		0.50±0.05
			T	75	T	T	T	T		0.20±0.05
			T	100	T	T	T	T		0
			100	100	0	0	T	0	OD	1.02±0.02
			T	T	T	60	T	T		0.46±0.04
			T	T	T	75	T	T		0.19±0.04
			T	T	T	100	T	T		0
			100	100	0	0	T	0	UD	1.03±0.02
			T	T	60	T	T	T		0.44±0.05
			T	T	75	T	T	T		0.18±0.04
			T	T	100	T	T	T		0
			100	0	100	0	T	0T	RED	1.03±0.02
			T	T	T	T	T	60		0.49±0.04
			T	T	T	T	T	75		0.24±0.04
			T	T	T	T	T	100		0
			100T	0	100	0	T	100	DIR	0
			75	T	T	T	T	T		0.25±0.04
			60	T	T	T	T	T		0.51±0.04
			0	T	T	T	T	T		1.03±0.02

Each case of increasing (0—'100%) and decreasing (100—'0%) of duty rate to be satisfied.(Except the mark •)

Manual valve position (Oil pressure)	VFS current [mA]	RPM	Operation (Duty rate %)						Damper Apply Pressure [^] (MPa)	Damper Release Pressure (MPa)
			LR	2ND	UD	OD	DCC	RED* ²		
D	200	2500	100	100	0	0	0	0	0.25-0.45	0.50-0.70
			T	T	T	T	50	T	0.20-0.45	0
			T	T	T	T	100	T	0.96-1.04	0
	900		100	100	0	0	0	0	0.12-0.22	0.25-0.45
			T	T	T	T	100	T	MIN. 0.29	0

[^] Each case of increasing and decreasing of DCC solenoid duty rate to be satisfied.

• The values are subject to change according to vehicle model or condition.

5. Is oil pressure value within specification?

YES

• Repair AUTO TRANSAXLE(Clutch or brake) as necessary and go to "Verification vehicle repair" procedure.

NO

• Replace AUTO TRANSAXLE (BODY CONTROL VALVE faulty) as necessary and go to "Verification vehicle repair " procedure.

VERIFICATION OF VEHICLE REPAIR E.,1617.

Refer to DTC P0731.

DTC P0741 TORQUE CONVERTER CLUTCH CIRCUIT - STUCK OFF

GENERAL DESCRIPTION EFFF8BF5

The PCM controls the locking or unlocking of the Torque Converter Clutch (or Damper Clutch) by applying hydraulic pressure. The main purpose of the TCC control is to save fuel by decreasing the hydraulic load inside the torque converter. The PCM outputs duty pulses to control the torque converter clutch control solenoid valve and hydraulic pressure is applied to the torque converter according to the torque converter clutch duty ratio value. When the duty ratio is high, high pressure is applied and the torque converter clutch is locked. The normal operating range of the torque converter clutch control duty ratio value is from 30%(unlocked) to 85%(locked).

DTC DESCRIPTION E8E5E59F

The PCM increases the duty ratio to engage the torque converter clutch, monitoring the slip rpms (difference between engine speed and turbine speed). To decrease the slip of the torque converter clutch, the PCM applies more hydraulic pressure by increasing the duty ratio. When the slip rpm does not drop down below the specification with 100% duty ratio, the PCM determines that the torque converter clutch is stuck OFF and sets this code.

DTC DETECTING CONDITION ECECF4AA

Item	Detecting Condition & Fail Safe	Possible cause
DTC Strategy	<ul style="list-style-type: none"> • Stuck "OFF" 	* TORQUE CONVERTER(DAMPER) CLUTCH : TCC <ul style="list-style-type: none"> • Faulty TCC or oil pressure system • Faulty TCC solenoid valve • Faulty body control valve • Faulty PCM
Enable Conditions	<ul style="list-style-type: none"> • TCC Duty cycled 0 or TCC Abnormal slip counters ^ 4 	
Threshold value	<ul style="list-style-type: none"> • TCC slip counter > 4 counts 	
Diagnostic Time	<ul style="list-style-type: none"> • 1 second 	
Fail Safe	<ul style="list-style-type: none"> • Stop the torque converter clutch control 	

MONITOR SCANTOOL DATA E87D6A25

1. Connect scantool to data link connector(DLC).
2. Engine "ON".
3. Select "D RANGE" and drive vehicle.
4. Monitor the "TORQUE CONVERTER(DAMPER) CLUTCH" parameter on the scantool.

Specification : TCC SLIP < 160RPM(In condition that TCC SOL. DUTY > 80%)

1.2 CUBBENT DATA 06/24

81. ENGINE SPEED 3459 rpm
04. INPUT SPEED SENSOR 3457 rpm
05. O/PUT SPEED SENSOE 3984 rpm
B6. DCCSU DUTV
B7. DAMP. CLUTCH SLIP
15. SELECT LEUEH POSI.
16. A/C SUIITCH
17. IDLE SWITCH

FIK | Pf1BI | FULL | HELP | [GBPH] | ECED

FIG. 1)

FIG. 1) : Normal status

5. Are "TCC SOLENOID DUTY and TCC SLIP" within specifications?

- Fault is intermittent caused by poor contact in the sensor's and/or PCM's connector or was repaired and PCM memory was not cleared. Thoroughly check connectors for looseness, poor connection, bending, corrosion, contamination, deterioration or damage. Repair or replace as necessary and go to "Verification vehicle repair" procedure.
- Go to "Component inspection" procedure.

COMPONENT INSPECTION EA18BAD6

1. CHECK TORQUE CONVERTER CLUTCH SOLENOID VALVE

- 1) Connect scantool to data link connector(DLC).
- 2) Ignition "ON" & Engine "OFF".
- 3) Select A/T solenoid valve actuator test and operate actuator test.
- 4) Can you hear operating tone for using TCC SOLENOID VALVE actuator testing function?

- Go to "CHECK OIL PRESSURE" as below.
- Replace "TCC SOLENOID VALVE" as necessary and go to "Verification vehicle repair" procedure.

2. CHECK OIL PRESSURE

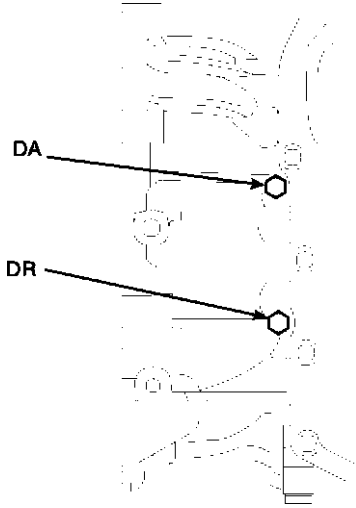

KKCF212B

- 1) Connect oil pressure gauge to "DA" and "DR" ports.
- 2) Ignition "ON" & Engine "OFF".
- 3) After connecting Scantool and monitor the "TCC SOLENIOD VALVE DUTY" parameter on the scantool data list.
- 4) Select the "D" range and accelerate engine speed to 2500 rpm.
- 5) Measure oil pressure.

Specification :

Manual valve position	VFS current(mA)	RPM	Operation (Duty rate %)						Damper Apply Pressure & (M Pa)	Damper Release Pressure (MPa)
			LR	2ND	UD	OD	DCC	RED*		
D	200	2500	100	100	0	0	0	0	0.25-0.45	0.50-0.70
			t	T	T	T	50	T	0.20-0.45	0
			t	T	T	T	100	T	0.96-1.04	0
	900		100	100	0	0	0	0	0.12-0.22	0.25-0.45
			t	T	T	T	100	T	MIN. 0.29	0

^ Each case of increasing and decreasing of DCC solenoid duty rate to be satisfied.

6) Is oil pressure value within specification?

YES

- Repair TORQUE CONVERTER CLUTCH(REPLACE Torque Converter) as necessary and go to "Verification vehicle repair" procedure.

NO

- Replace A/T assembly (or valve body assembly) as necessary and go to "Verification vehicle repair" procedure.

VERIFICATION OF VEHICLE REPAIR EMFEASA

After a repair, it is essential to verify that the fault has been corrected.

1. Connect scan tool and select "Diagnostic Trouble Codes(DTCs)" mode.
2. Using a scantool, Clear DTC.
3. Operate the vehicle within DTC Enable conditions in General information.
4. Are any DTCs present ?

- Go to the applicable troubleshooting procedure.

NO

- System performing to specification at this time.

DTC P0742 TORQUE CONVERTER CLUTCH CIRCUIT - STUCK ON

GENERAL DESCRIPTION EBBE12CB

Refer to DTC P0741.

DTC DESCRIPTION EBA8C5FD

The PCM sets this code when the absolute value of RPM difference between engine speed and input shaft speed is less than 20 RPM.

DTC DETECTING CONDITION EB7BA778

Item	Detecting Condition & Fail Safe	Possible cause
DTC Strategy	<ul style="list-style-type: none"> • Stuck "ON" 	<p>* TORQUE CONVERTER(DAMPER) CLUTCH : TCC</p> <ul style="list-style-type: none"> • Faulty TCC or oil pressure system • Faulty TCC solenoid valve • Faulty body control valve • Faulty PCM
Enable Conditions	<ul style="list-style-type: none"> • Engine state=Run • Throttle position sensor value ^ 20% • TM output speed > 500 rpm • Manifold air pressure > 60 kPa • Current gear =1 or 2 or 3 or 4 or 5 	
Threshold value	<ul style="list-style-type: none"> • Absolute value of RPM difference between engine and TM input speeds 20 rpm 	
Diagnostic Time	<ul style="list-style-type: none"> • 1 second 	
Fail Safe	<ul style="list-style-type: none"> • Stop the torque converter clutch control 	

MONITOR SCANTOOL DATA E95BD09B

Refer to DTC P0741.

COMPONENT INSPECTION E0AA65DC

Refer to DTC P0741.

VERIFICATION OF VEHICLE REPAIR EBEDACES

Refer to DTC P0741.

DTC P0743 TORQUE CONVERTER CLUTCH CIRCUIT - ELECTRICAL

COMPONENT LOCATION E5E8A9EB

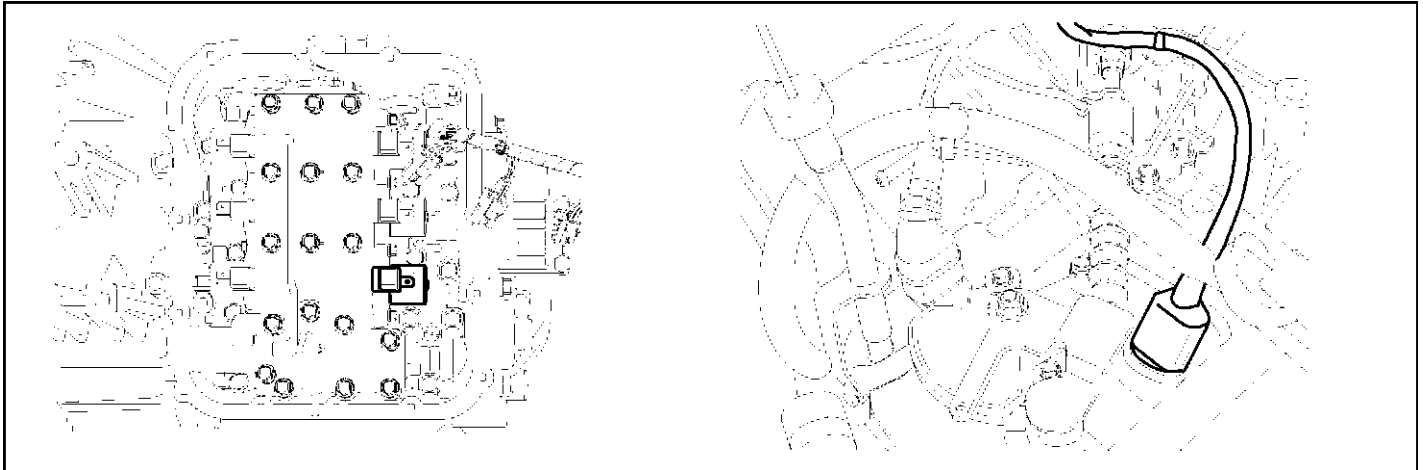

KKCF213A

GENERAL DESCRIPTION E527CC47

Refer to DTC P0741.

DTC DESCRIPTION E7FEDB1F

The PCM checks the torque converter clutch control signal by monitoring the feedback signal from the solenoid valve drive circuit. If an unexpected signal is monitored (for example, high voltage is detected when low voltage is expected, or low voltage is detected when high voltage is expected), the PCM judges that the torque converter clutch solenoid valve circuit is malfunctioning and sets this code.

DTC DETECTING CONDITION EAAFAEAD

Item	Detecting Condition & Fail Safe	Possible cause
DTC Strategy	<ul style="list-style-type: none"> • Check voltage range 	<p>* TORQUE CONVERTER(DAMPER) CLUTCH : TCC</p> <ul style="list-style-type: none"> • Open or short in circuit • Faulty TCC SOLENOID VALVE • Faulty PCM
Enable Conditions	<ul style="list-style-type: none"> • Engine state=Run • Engine runtime > 0.5 sees • Battery voltage > 11V and 16 V • Transmission relay state : Relay on • Gear shifting is completed 	
Threshold value	<ul style="list-style-type: none"> • When the PCM detects electric or electronic abnormalness such as short circuit or out of range voltage. 	
Diagnostic Time	<ul style="list-style-type: none"> • More than 5 seconds 	
Fail Safe	<ul style="list-style-type: none"> • Locked in 3rd gear.(Control relay off) 	

SPECIFICATION E0D7F194

Solenoid Valve for Pressure Control

- Sensor type : Normal open 3-way
- Operating temperature : -22~266°F(-30°C~130°C)
- Frequency :
 - LR, 2ND, UD, OD, RED : 61.27Hz (at the ATF temp. -20°C above)
 - DCC : 30.64Hz
 - VFS : 600 ± 20Hzs

- Internal resistance :
 - 2.6-3.4Q (68°F or 20°C) - LR, 2ND, UD, OD, RED, DCC
 - 4.0-4.7Q (68°F or 20°C) - VFS

- Surge voltage : 56 V(except VFS)

MONITOR SCANTOOL DATA E188BEB1

1. Connect scantool to data link connector(DLC)
2. Engine "ON".
3. Monitor the "TCC SOL. VALVE" parameter on the scantool
4. Select "D RANGE" and Operate "TCC SOLENOID DUTY" more than 85%

1. 2 CUREEMI DH1fi 86/24

81. ENGINE SPEED 3459 rpn
04. INPUT SPEED SENSOE 3457 rpn
05. O/PUT SPEED SENSOE 3984 rpn
B6. DCCSO DUTU
07. DAMP. CLUTCH SLIP rpn
15. SELECT LEUEE POSI.
16. A/C SWITCH
17. IDLE SWITCH

FIK | Pf1ET| |FULL| |HELP| |GRPH| ECED

FIG.1)

FIG.1) : Normal status

ELQE041A

5. Does "TCC SOLENOID DUTY " follow the reference data?

- Fault is intermittent caused by poor contact in the sensor's and/or PCM's connector or was repaired and PCM memory was not cleared. Thoroughly check connectors for looseness, poor connection, bending, corrosion, contamination, deterioration or damage. Repair or replace as necessary and go to "Verification vehicle repair" procedure.

NO

- Go to "Terminal & connector inspection " procedure.

TERMINAL & CONNECTOR INSPECTION EBBIBDAE

1. Many malfunctions in the electrical system are caused by poor harness and terminals. Faults can also be caused by interference from other electrical systems, and mechanical or chemical damage.
2. Thoroughly check connectors for looseness, poor connection, bending, corrosion, contamination, deterioration, or damage.
3. Has a problem been found?

YES

- Repair as necessary and then go to "Verification of vehicle repair" procedure.

NO

- Go to "Power supply circuit inspection" procedure.

POWER SUPPLY CIRCUIT INSPECTION ESSCSOSD

1. Disconnect "A/T SOLENOID VALVE" connector.
2. Measure voltage between terminal "6" of the sensor harness connector and chassis ground.
3. Turn ignition switch OFF -> ON

Specification: 12V is measured only for approx. 0.5sec

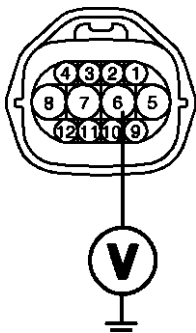

SOLENOID VALVE

- 3.UD solenoid valve
- 4.2ND solenoid valve
- 5. A/T battery
- 6. A/T battery
- 7. VFS solenoid valve(+)
- 8. VFS solenoid valve(-)
- 9. TCC solenoid valve
- 11. LR solenoid valve
- 12.0D solenoid valve

EKRF713A

4. Is voltage within specifications?

YES

- Go to "Signal circuit inspection" procedure.

NO

- Check that A/T-20A fuse in engine room junction is installed or not blown.
- Check for open in harness. Repair as necessary and go to "Verification vehicle repair" procedure.

SIGNAL CIRCUIT INSPECTION E9BD89DA

1. Check signal circuit open inspection.
 - 1) Ignition "OFF".
 - 2) Disconnect "A/T SOLENOID VALVE" connector and "PCM" connector.
 - 3) Measure resistance between terminal "9" of the ATM SOLENOID VALVE harness connector and terminal "43" of the PCM harness connector B.

Specification: approx. 0 Ω

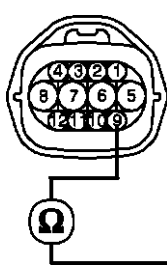

ATM SOLENOID VALVE

- 3. UD solenoid valve
- 4. 2ND solenoid valve
- 5. A/T battery
- 6. A/T battery
- 7. VFS solenoid valve(+)
- 8. VFS solenoid valve(-)
- 9. TCC solenoid valve
- 11. LR solenoid valve
- 12. OD solenoid valve

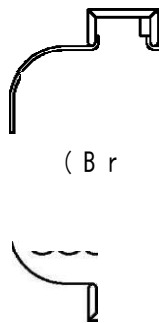

X51150X49148X*x*xj5^3^1
X71170169168fc7T?)(^4^2^*

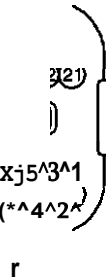

- 3. UD solenoid valve
- 22. LR solenoid valve
- 42. OD solenoid valve
- 43. DCC solenoid valve
- 45. 2ND solenoid valve
- 59. VFS solenoid valve(-)
- 75. VFS solenoid valve(+)

EKRF713B

- 4) Is resistance within specifications?
 - Go to "Check signal circuit short inspection" procedure.
 - Check for open in harness. Repair as necessary and go to "Verification vehicle repair" procedure.

ATA -98

2. Check signal circuit short inspection

- 1) Ignition "OFF".
- 2) Disconnect "A/T SOLENOID VALVE" connector and "PCM" connector.
- 3) Measure resistance between terminal "9" of the ATM SOLENOID VALVE harness and chassis ground.

Specification: Infinite

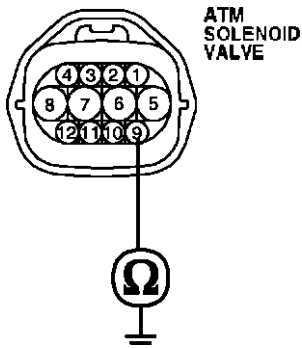

- 3.UD solenoid valve
- 4.2ND solenoid valve
- 5.ATT battery
- 6. A/T battery
- 7. VFS solenoid valve(+)
- 8. VFS solenoid valve(-)
- 9. T C C solenoid valve
- 11. LR solenoid valve
- 12.0D solenoid valve

EKRF713C

4) Is resistance within specifications?

YES

- Go to "Component inspection" procedure.

NO

- Check for short to ground in harness. Repair as necessary and go to "Verification vehicle repair" procedure.

COMPONENT INSPECTION E386A86C

1. CHECK SOLENOID VELVE

- 1) Ignition "OFF".
- 2) Disconnect "A/T SOLENOID VALVE" connector.
- 3) Measure resistance between terminal "9" and terminal "6" of the ATM SOLENOID VALVE harness connector.

Specification: Approximately 2.6-3.4 Ω [20°C(68°F)]

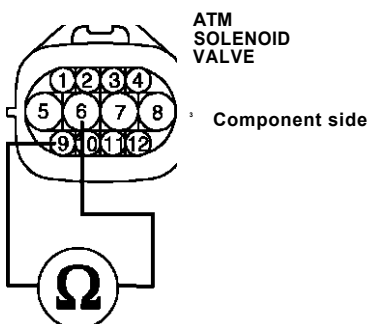

- 3.UD solenoid valve
- 4.2ND solenoid valve
- 5. A/T battery
- 6. A/T battery
- 7. VFS solenoid valve(+)
- 8. VFS solenoid valve(-)
- 9. T C C solenoid valve
- 11. LR solenoid valve
- 12.0D solenoid valve

EKRF713D

4) Is resistance within specification?

YES

- Go to "CHECK PCM" as below.

NO

- Replace TCC SOLENOID VALVE as necessary and go to "Verification vehicle repair" procedure.

2. CHECK PCM

1) Connect scantool to data link connector(DLC).

2) Ignition "ON" & Engine "OFF".

3) Select A/T solenoid valve actuator test and operate actuator test.

4) Can you hear operating sound for TCC SOLENOID VALVE actuator testing function?

- Go to "Verification vehicle repair" procedure.

NO

- Replace PCM as necessary and go to "Verification vehicle repair" procedure.

ACTUATOR TEST CONDITION

1. IG SWITCH ON
2. TRANSAXLE RANGE SWITCH is normal
3. P RANGE
4. Vehicle Speed Okm/h
5. Throttle position sensor < 1V
6. IDLE SWITCH ON
7. ENGINE RPM 0

VERIFICATION OF VEHICLE REPAIR E A I E E

Refer to DTC P0741.

DTC P0746 PRESSURE CONTROL SOLENOID VALVE A - PERFORMANCE OR STUCK OFF

COMPONENT LOCATION EE186281

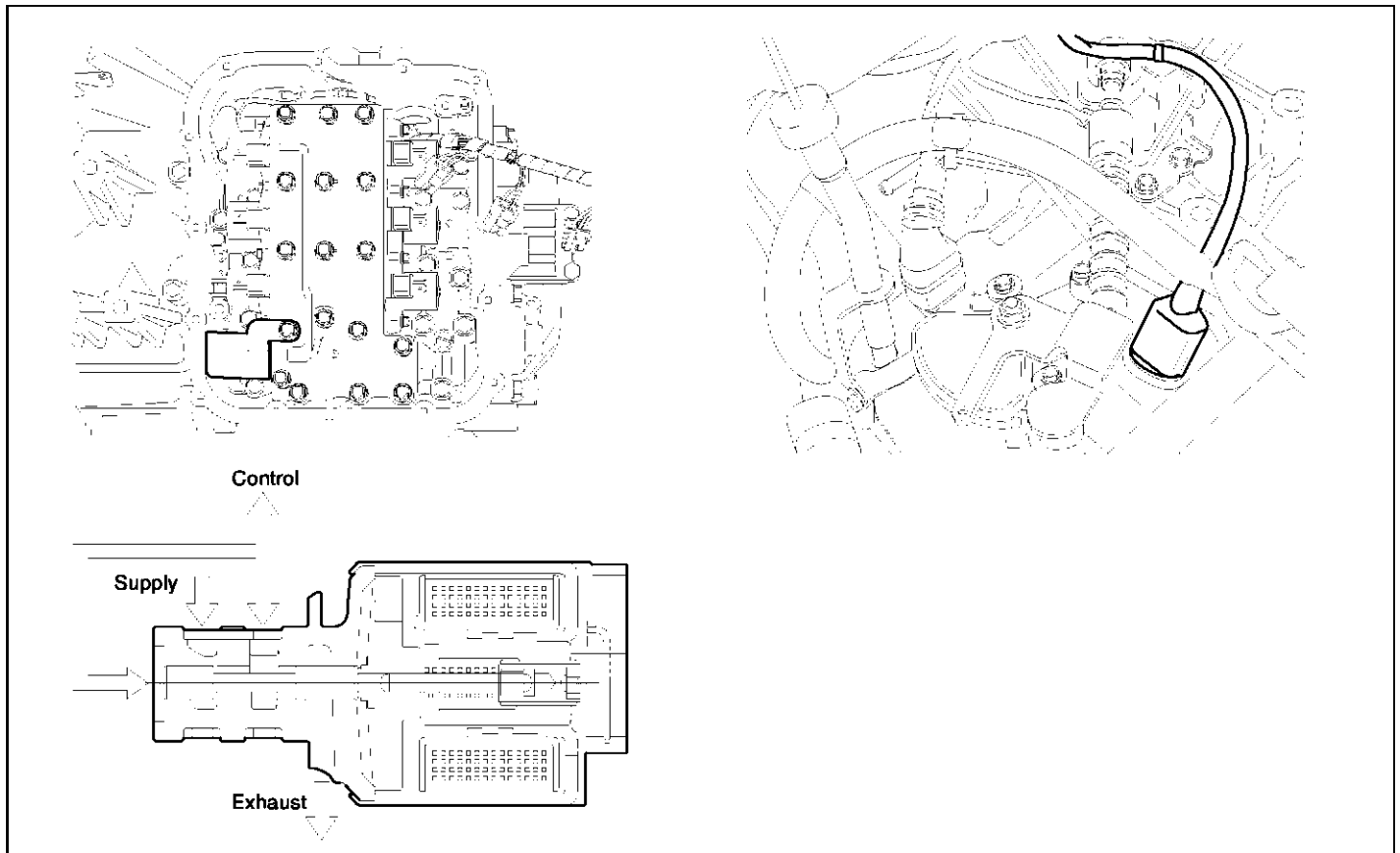

EKRF714A

GENERAL DESCRIPTION EAC2A883

In order to control the optimum line pressure and improve the efficiency of power according to the maximum efficiency of an oil pump, VFS (Variable Force Solenoid) valve has been added in the valve body hydraulic circuit.

VFS(Variable Force Solenoid): It can be said as a linear solenoid and makes detailed spool control available with the closer duty($600 \pm 20\text{Hz}$) than PWM(Pulse Width Modulation-60Hz). PWM repeats ON/OFF signals and decides the operation flux according to the 'ON' time. But, VFS decides the operation flux according to the degree that the spool jams water course.

DTC DETECTING CONDITION EDC78BDA

Item	Detecting Condition & Fail Safe	Possible cause
DTC Strategy	<ul style="list-style-type: none"> Check oil pressure and feedback current value 	<ul style="list-style-type: none"> Open or short in circuit Faulty VFS SOLENOID VALVE Faulty PCM
Enable Conditions	<ul style="list-style-type: none"> Engine state=Run VFS is enabled 	
Threshold value	<ul style="list-style-type: none"> Current operating state of VFS: Locked off until reset 	
Diagnostic Time	<ul style="list-style-type: none"> More than 1 second 	
Fail Safe	<ul style="list-style-type: none"> Stop the VFS control 	

SPECIFICATION EFA68D86

Solenoid Valve for Pressure Control

- Sensor type : Normal open 3-way
- Operating temperature : -22~266°F(-30°C - 130°C)
- Frequency :
 - LR, 2ND, UD, OD, RED : 61.27Hz (at the ATF temp. -20°C above)
 - DCC : 30.64Hz
 - VFS : 600 ± 20Hz
- Internal resistance :
 - 2.6-3.4Q (68°F or 20°C) - LR, 2ND, UD, OD, RED, DCC
 - 4.0-4.7Q (68°F or 20°C) - VFS
- Surge voltage : 56 V(except VFS)

Type: 3 way VFS valve for hydraulic control

Dither Frequency : 600±20 Hz

Sweep time : 20 sec

VFS CONTROL PRESSURS

Input Current(mA)	Control Pressure (No line pressure)			
	Increasing Current			Decreasing Current
	MAX. (Kgf/cm ²) [Kpa]	MIN.(Kgf/cm ²) [Kpa]	A (Kgf/cm ²) [Kpa]	MIN.(Kgf/cm ²) [Kpa]
100	6.52 [639]	5.87 [575]	[64]	
200	6.23 [611]	5.70 [559]	[52]	5.43 [532]
300	5.76 [564]	5.24 [514]	[50]	4.49 [484]
400	5.08 [498]	4.59 [450]	[48]	4.30 [421]
500	4.24 [416]	3.78 [370]	[46]	3.52 [345]
700	2.29 [224]	1.82 [178]	[46]	1.51 [148]
800	1.41 [138]	0.09 [88]	[50]	0.58 [57]
900	0.65 [64]	0.14 [14]	[50]	0 [0]
1,000	0.24 [24]	0 [0]	[24]	
1,100	0.24 [24]	0 [0]	[24]	

Test condition

Ps : Supply Pressure (Ps = 7.1 ±0.3 KGf/cm²)

Pc : Control Pressure

Pex : Exhaust Pressure (Atmosphere pressure)

ATF : DIAMOND ATF SP-III

ATF temperature : 30±3°C (86°F)

- Coil resistance : 4.35±35Q

- Dither frequency : 600±20Hz

In case of VFS solenoid valve, the relation between duty and oil pressure can't be expressed.

TERMINAL & CONNECTOR INSPECTION ESSFLC.

Refer to DTC P0743.

ATA-102

POWER SUPPLY CIRCUIT INSPECTION E,CCBF4E

1. Disconnect "A/T SOLENOID VALVE" connector.
2. Measure voltage between terminal "7" of the sensor harness connector and chassis ground.
3. Turn ignition switch OFF -> ON

Specification: 12V is measured only for approx. 0.5sec

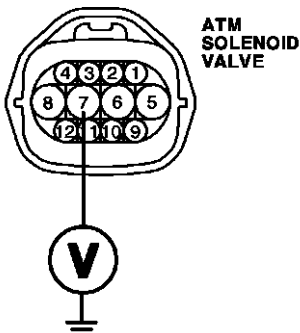

- 3.UD solenoid valve
- 4.2ND solenoid valve
- 5.A/T battery
- 6. A/T battery
- 7.VFS solenoid valve(+)
- 8.VFS solenoid valve(-)
- 9.TCC solenoid valve
- 11. LR solenoid valve
- 12.0D solenoid valve

EKRF714B

4. Is voltage within specifications?

YES

- Go to "Signal circuit inspection" procedure.

NO

- Check that A/T-20A fuse in engine room junction is installed or not blown.
- Check for open in harness. Repair as necessary and go to "Verification vehicle repair" procedure.

SIGNAL CIRCUIT INSPECTION EA21,2,,

1. Check signal circuit open inspection.
 - 1) Ignition "OFF".
 - 2) Disconnect "ATM SOLENOID VALVE" connector and "PCM" connector.
 - 3) Measure resistance between terminal "8" of the ATM SOLENOID VALVE harness connector and terminal "59" of the PCM harness connector.

Specification: approx. 0 £3

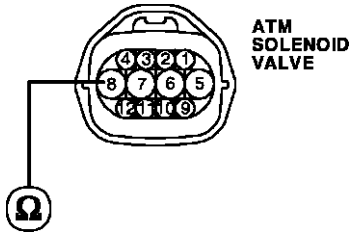

- 3.UD solenoid valve
- 4.2ND solenoid valve
- 5. A/T battery
- 6. A/T battery
- 7. VFS solenoid valve(+)
- 8. VFS solenoid valve(-)
- 9. TCC solenoid valve
- 11. LR solenoid valve
- 12.OD solenoid valve

- 3. UD solenoid valve
- 22. LR solenoid valve
- 42. OD solenoid valve
- 43. DCC solenoid valve
- 45. 2ND solenoid valve
- 59. VFS solenoid valve(-)
- 75. VFS solenoid valve(+)

JOL



r

4) Is resistance within specifications?

- Go to "Check signal circuit short inspection" procedure.
- Check for open in harness. Repair as necessary and go to "Verification vehicle repair" procedure.

2. Check signal circuit short inspection

- 1) Ignition "OFF".
- 2) Disconnect "ATM SOLENOID VALVE" connector and "PCM" connector
- 3) Measure resistance between terminal "8" of the ATM SOLENOID VALVE harness and chassis ground.

Specification: Infinite

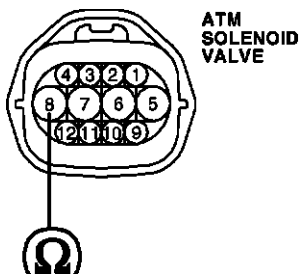

- 3.UD solenoid valve
- 4.2ND solenoid valve
- 5. A/T battery
- 6. A/T battery
- 7. VFS solenoid valve(+)
- 8. VFS solenoid valve(-)
- 9. TCC solenoid valve
- 11. LR solenoid valve
- 12.OD solenoid valve

ATA-104

4) Is resistance within specifications?

YES

- Go to "Component inspection" procedure.

NO

- Check for short to ground in harness. Repair as necessary and go to "Verification vehicle repair" procedure.

COMPONENT INSPECTION ECB2DBA3

1. CHECK SOLENOID VALVE

- 1) Ignition "OFF".
- 2) Disconnect "ATM SOLENOID VALVE" connector.
- 3) Measure resistance between terminal "7" and terminal "8" of the ATM SOLENOID VALVE harness connector.

Specification: Approximately 4.0-4.7 Ω [20°C(68°F)]

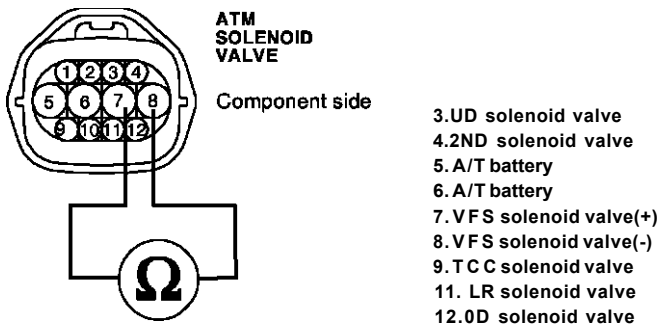

EKRF714E

4) Is resistance within specification?

- Go to "CHECK PCM" as below.

NO

- Replace VFS SOLENOID VALVE as necessary and go to "Verification vehicle repair" procedure.

2. CHECK PCM

- 1) Connect scantool to data link connector(DLC).
- 2) Ignition "ON" & Engine "OFF".
- 3) Select A/T Solenoid valve Actuator test and Operate Actuator test.
- 4) Can you hear operating sound for VFS SOLENOID VALVE actuator testing function?

YES

- Go to "Verification vehicle repair" procedure.

NO

- Replace PCM as necessary and go to "Verification vehicle repair" procedure.

ACTUATOR TEST CONDITION

1. IG SWITCH ON
2. TRANSAXLE RANGE SWITCH is normal
3. P RANGE
4. Vehicle Speed 0km/h
5. Throttle position sensor < 1V
6. IDLE SWITCH ON
7. ENGINE RPM 0

VERIFICATION OF VEHICLE REPAIR E67,E,AB

Refer to DTC P0741.

DTC P0748 PRESSURE CONTROL SOLENOID VALVE A - ELECTRICAL

COMPONENT LOCATION E27EEDCB

Refer to DTC P0746.

GENERAL DESCRIPTION EBECFADC

Refer to DTC P0746.

DTC DESCRIPTION EEB9D3AD

PCM inspects VFS by monitoring the feedback signal from the solenoid controlled valves. When such malfunction as case that, for example, low voltage should be inputted but High voltage is inputted and vice versa), PCM decides that VFS is malfunctioning and gives this code.

DTC DETECTING CONDITION E864DF61

Item	Detecting Condition & Fail Safe	Possible cause
DTC Strategy	<ul style="list-style-type: none"> • Check oil pressure and feedback current value 	<ul style="list-style-type: none"> • Open or short in circuit • Faulty VFS SOLENOID VALVE • Faulty PCM
Enable Conditions	<ul style="list-style-type: none"> • Engine state=Run • Engine runtime > 0.5 sees • Battery voltage > 11V and 16V • Transmission relay state : Relay on • Gear shifting is completed 	
Threshold value	<ul style="list-style-type: none"> • When the PCM detects electric or electronic abnormalness such as short circuit or out of range voltage 	
Diagnostic Time	<ul style="list-style-type: none"> • More than 5 seconds 	
Fail Safe	<ul style="list-style-type: none"> • Stop the VFS control 	

SPECIFICATION E60B905C

Refer to DTC P0746.

TERMINAL & CONNECTOR INSPECTION EBSADSS

Refer to DTC P0743.

POWER SUPPLY CIRCUIT INSPECTION EE,DBA2,

Refer to DTC P0746.

SIGNAL CIRCUIT INSPECTION EFSACMO

Refer to DTC P0746.

COMPONENT INSPECTION EDAE9A6B

Refer to DTC P0746.

Refer to DTC P0741.

DTC P0750 SHIFT CONTROL SOLENOID VALVE A CIRCUIT MALFUNCTION

COMPONENT LOCATION EF0B7B7A

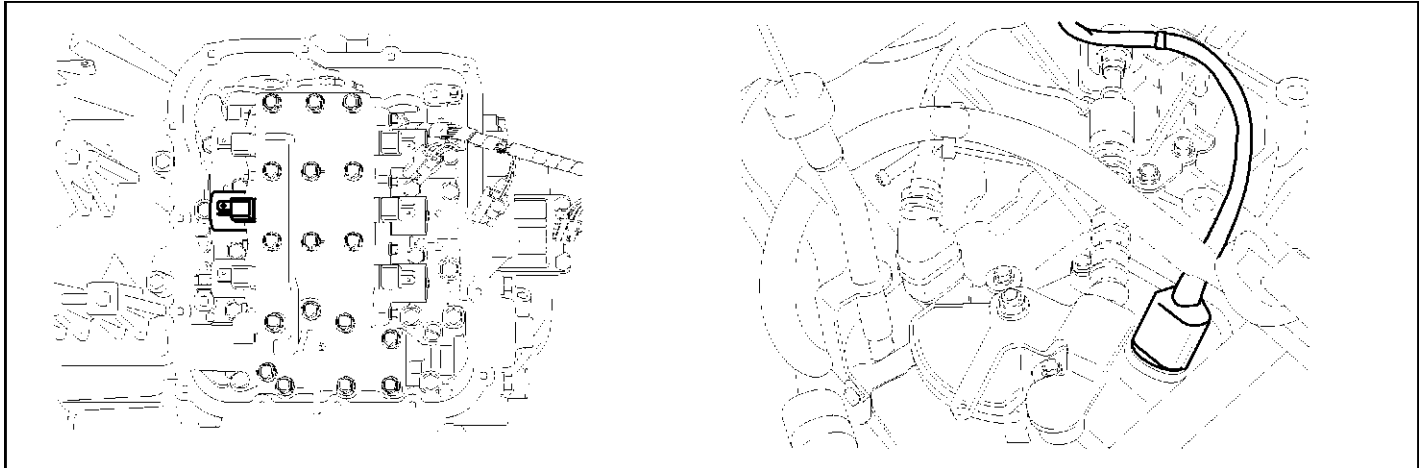

KKCF213G

GENERAL DESCRIPTION EFC922A2

The Automatic transmission changes the gear position of the transmission by utilizing a combination of clutches and brakes, which are controlled by solenoid valves. This automatic transmission consists of a: LR (Low and Reverse Brake), 2ND (2nd Brake), UD (Under Drive Clutch), OD (Over Drive Clutch), REV (Reverse Clutch), and a RED (Reduction Brake, only for 5 speed transmissions). The LR brake is engaged in the 1st gear and P/R/N gear positions.

DTC DESCRIPTION EACF22CC

The PCM checks the low and reverse control signal by monitoring the feedback signal from the solenoid valve drive circuit. If an unexpected signal is monitored (for example, high voltage is detected when low voltage is expected, or low voltage is detected when high voltage is expected), the PCM judges that the low and reverse control solenoid circuit is malfunctioning and sets this code.

DTC DETECTING CONDITION EADFAAAD

Item	Detecting Condition & Fail Safe	Possible cause
DTC Strategy	<ul style="list-style-type: none"> • Check voltage range 	<ul style="list-style-type: none"> • Open or short in circuit • Faulty LR SOLENOID VALVE • Faulty PCM
Enable Conditions	<ul style="list-style-type: none"> • Engine state=Run • Engine runtime > 0.5 sees • Battery voltage > 11V and 16 V • Transmission relay state : Relay on • Gear shifting is completed 	
Threshold value	<ul style="list-style-type: none"> • When the PCM detects electric or electronic abnormalness such as short circuit or out of range voltage. 	
Diagnostic Time	<ul style="list-style-type: none"> • More than 5 seconds 	
Fail Safe	<ul style="list-style-type: none"> • Locked in 3rd gear.(Control relay off) 	

SPECIFICATION E2726877

Refer to DTC P0743.

MONITOR SCANTOOL DATA EA251635

1. Connect scantool to data link connector(DLC).
2. Engine "ON".
3. Monitor the "LR SOL. VALVE" parameter on the scantool.
4. Shift gear position 1st to 2nd.

Specification: 1st — 0%, 2nd -> 100%

1. 2 CUBKENT DATA

LftHSU DUTV	0.0 %
UDSO DUTV	0.0 A
2NDSU DUTV	100 0%
ODSU DUTV	100 0%
TRANSAXLE RANGE SW	D
THROTTLE F. SENSOR	12.9 %
FLUID TENP. SENSOR	66 °C
CRK POSITION SNSR	B07 rpi*

FIH SCRNV FULL PART GRPH HELP

FIG.1)

FIG. 1) 1st gear
FIG. 2) 2nd gear

1. 2 CURRENT DATA

LfiRSU DUTV	100.0%
UDSO DUTV	0.0 *
2NDSO DUTV	0.0 X
OTJQU 3UT	
SHIFT POSITION	2
THROTTLE P. SENSOR	12.9 X
FLUID TENP. SENSOR	71 ° C
CEK POSITION SNSR	B35 rpn

FIX SCRNV FULL PART GRPH HELP

FIG.2)

ELQE045A

Does "LR SOLENOID DUTY " follow the reference data?

- Fault is intermittent caused by poor contact in the sensor's and/or PCM's connector or was repaired and PCM memory was not cleared. Thoroughly check connectors for looseness, poor connection, bending, corrosion, contamination, deterioration or damage. Repair or replace as necessary and go to "Verification vehicle repair" procedure.

- Go to "Terminal & connector inspection " procedure.

TERMINAL & CONNECTOR INSPECTION E,FE,1C6

Refer to DTC P0743.

ATA-110

POWER SUPPLY CIRCUIT INSPECTION E0FF0DEC

1. Disconnect "ATM SOLENOID VALVE" connector.
2. Measure voltage between terminal "6" of the sensor harness connector and chassis ground.
3. Turn ignition switch OFF -> ON.

Specification: 12V is measured only for approx. 0.5sec

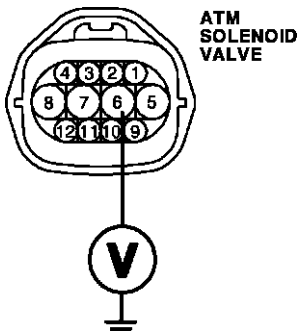

- 3.UD solenoid valve
- 4.2ND solenoid valve
- 5. A/T battery
- 6. A/T battery
- 7. VFS solenoid valve(+)
- 8. VFS solenoid valve(-)
- 9. DCC solenoid valve
- 11. LR solenoid valve
- 12.0D solenoid valve

EKRF716A

4. Is voltage within specifications?

YES

- Go to "Signal circuit inspection" procedure.

NO

- Check that A/T-20A fuse in engine room junction is installed or not blown.
- Check for open in harness. Repair as necessary and go to "Verification vehicle repair" procedure.

SIGNAL CIRCUIT INSPECTION E35478FC

1. Check signal circuit open inspection

- 1) Ignition "OFF".
- 2) Disconnect "ATM SOLENOID VALVE" connector and "PCM" connector.
- 3) Measure resistance between terminal "11" of the ATM SOLENOID VALVE harness connector and terminal "22" of the PCM harness connector B.

Specification: approx. 0 Ω

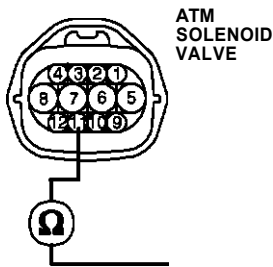

- 3.UD solenoid valve
- 4.2ND solenoid valve
- 5. A/T battery
- 6. A/T battery
- 7. VFS solenoid valve(+)
- 8. VFS solenoid valve(-)
- 9. DCC solenoid valve
- 11. LR solenoid valve
- 12. OD solenoid valve

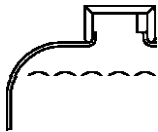

JOL

- 3.UD solenoid valve
- 22.LR solenoid valve
- 42.OD solenoid valve
- 43.DCC solenoid valve
- 45.2ND solenoid valve
- 59.VFS solenoid valve(-)
- 75.VFS solenoid valve(+)



r

4) Is resistance within specifications?

- Go to "Check signal circuit short inspection" procedure.
- Check for open in harness. Repair as necessary and go to "Verification vehicle repair" procedure.

2. Check signal circuit short inspection

- 1) Ignition "OFF".
- 2) Disconnect "ATM SOLENOID VALVE" connector and "PCM" connector.
- 3) Measure resistance between terminal "11" of the ATM SOLENOID VALVE harness and chassis ground.

Specification: Infinite

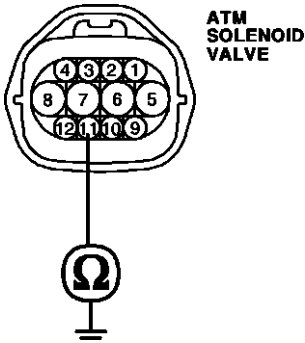

- 3.UD solenoid valve
- 4.2ND solenoid valve
- 5. A/T battery
- 6. A/T battery
- 7. VFS solenoid valve(+)
- 8. VFS solenoid valve(-)
- 9. DCC solenoid valve
- 11. LR solenoid valve
- 12.0D solenoid valve

EKRF716C

4) Is resistance within specifications?

YES

- Go to "Component inspection" procedure.

NO

- Check for short to ground in harness. Repair as necessary and go to "Verification vehicle repair" procedure.

COMPONENT INSPECTION ECED888A

1. CHECK SOLENOID VELVE

- 1) Ignition "OFF".
- 2) Disconnect "ATM SOLENOID VALVE" connector.
- 3) Measure resistance between terminal "11" and terminal "6" of the ATM SOLENOID VALVE harness connector.

Specification: Approximately 2.6-3.4 Q [20°C(68°F)]

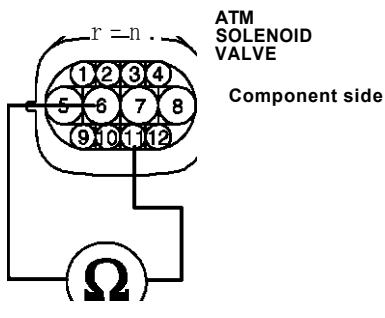

- 3.UD solenoid valve
- 4.2ND solenoid valve
- 5. A/T battery
- 6. A/T battery
- 7. VFS solenoid valve(+)
- 8. VFS solenoid valve(-)
- 9. DCC solenoid valve
- 11. LR solenoid valve
- 12.0D solenoid valve

EKRF716D

4) Is resistance within specification?

YES

- Go to "CHECK PCM" as below.

NO

- Replace LR SOLENOID VALVE as necessary and go to "Verification vehicle repair" procedure.

2. CHECK PCM

1) Connect scantool to data link connector(DLC).

2) Ignition "ON" & Engine "OFF".

3) Select A/T solenoid valve actuator test and operate actuator test.

4) Can you hear operating sound for LR SOLENOID VALVE actuator testing function?

- Go to "Verification vehicle repair" procedure.

NO

- Replace PCM as necessary and go to "Verification vehicle repair" procedure.

ACTUATOR TEST CONDITION

1. IG SWITCH ON
2. TRANSAXLE RANGE SWITCH is normal
3. P RANGE
4. Vehicle Speed 0km/h
5. Throttle position sensor < 1V
6. IDLE SWITCH ON
7. ENGINE RPM 0

VERIFICATION OF VEHICLE REPAIR EF..D26B

Refer to DTC P0741.

DTC P0755 SHIFT CONTROL SOLENOID VALVE B CIRCUIT MALFUNCTION

COMPONENT LOCATION EEEFA6A

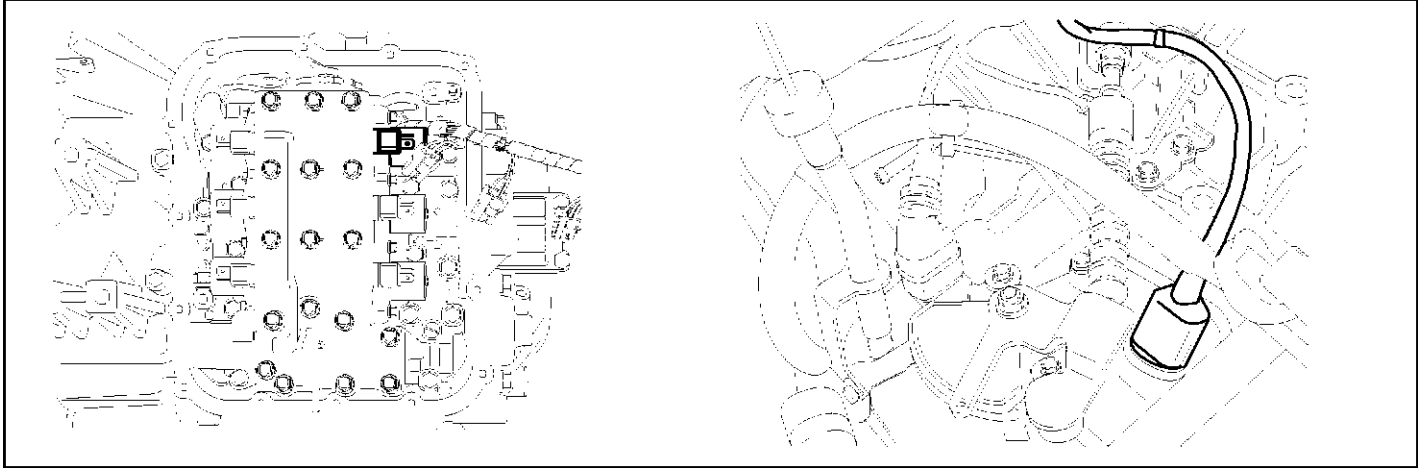

KKCF213H

GENERAL DESCRIPTION E5BE6978

The Automatic transmission changes the gear position of the transmission by utilizing a combination of clutches and brakes, which are controlled by solenoid valves. This automatic transmission consists of a: LR (Low and Reverse Brake), 2ND (2nd Brake), UD (Under Drive Clutch), OD (Over Drive Clutch), REV (Reverse Clutch), and a RED (Reduction Brake, only for 5 speed transmissions).

The UD clutch is engaged in the 1 st/2nd/3rd/4th gear positions.

DTC DESCRIPTION EE614343

The PCM checks the UD clutch control signal by monitoring the feedback signal from the solenoid valve drive circuit. If an unexpected signal is monitored (for example, high voltage is detected when low voltage is expected, or low voltage is detected when high voltage is expected), the PCM judges that the UD clutch control solenoid circuit is malfunctioning and sets this code.

DTC DETECTING CONDITION E8C5E236

Item	Detecting Condition & Fail Safe	Possible cause
DTC Strategy	<ul style="list-style-type: none"> • Check voltage range 	<ul style="list-style-type: none"> • Open or short in circuit • Faulty UD SOLENOID VALVE • Faulty PCM
Enable Conditions	<ul style="list-style-type: none"> • Engine state=Run • Engine runtime > 0.5 sees • Battery voltage > 11V and 16 V • Transmission relay state : Relay on • Gear shifting is completed 	
Threshold value	<ul style="list-style-type: none"> • When the PCM detects electric or electronic abnormalness such as short circuit or out of range voltage. 	
Diagnostic Time	<ul style="list-style-type: none"> • More than 5 seconds 	
Fail Safe	<ul style="list-style-type: none"> • Locked in 3rd gear.(Control relay off) 	

SPECIFICATION E4DAE0FC

Refer to DTC P0743.

MONITOR SCANTOOL DATA EC8F5C8F

1. Connect scantool to data link connector(DLC)
2. Engine "ON".
3. Monitor the "UD SOL. VALVE" parameter on the scantool.
4. Shift gear position "N" to "D".

Specification: P/N — 100%, D -> 0.0%

1.2 CUBHENT DATA

ICC SOLENOID DUTV	B.0 %
LB SOLENOID DUTV	B.0 X
UD SOLENOID DUTV	100.0%
2ND SOLENOID DUTV	100.0%
OD SOLENOID DUTV	100.0%
SHIFT POSITION	
SELECT LEVER SW.	
ENGINE TORQUE	14.9 X

1. Z CUBRENT DATA

LfIRSU DUTV	0.0 4
UDSU DUTV	
2NDSU DUTV	100.0%
ODSU_DUTV__	_100_0fe
TBANSAXLE RANGE SU	D
THROTTLE P.SENSOR	12.9 4
FLUID TENP.SENSOR	66 °C
CBK POSITION SNSR	807 rpn

FIX SCRN FULL PABT GBPH HELP

FIG.1)

FIX SCBN FULL PART GRPH HELP

FIG.2)

FIG. 1) P/N Range

FIG. 2) D Range

ELQE046A

Does "UD SOLENOID DUTY " follow the reference data?

- Fault is intermittent caused by poor contact in the sensor's and/or PCM's connector or was repaired and PCM memory was not cleared. Thoroughly check connectors for looseness, poor connection, bending, corrosion, contamination, deterioration or damage. Repair or replace as necessary and go to "Verification vehicle repair" procedure.

NO

- Go to "Terminal & connector inspection" procedure.

TERMINAL & CONNECTOR INSPECTION EDA52D,0

Refer to DTC P0743.

POWER SUPPLY CIRCUIT INSPECTION EBDEFDFS

1. Disconnect "ATM SOLENOID VALVE" connector.
2. Measure voltage between terminal "5" of the sensor harness connector and chassis ground.
3. Turn ignition switch OFF -> ON.

Specification: 12V is measured only for approx. 0.5sec

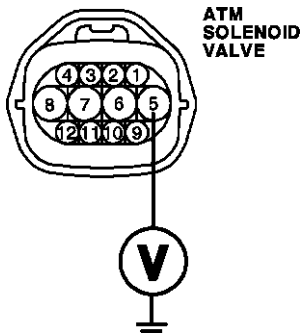

- 3.UD solenoid valve
- 4.2ND solenoid valve
- 5. A/T battery
- 6. A/T battery
- 7. VFS solenoid valve(+)
- 8. VFS solenoid valve(-)
- 9. DCC solenoid valve
- 11. LR solenoid valve
- 12.0D solenoid valve

EKRF717A

4. Is voltage within specifications?

YES

- Go to "Signal circuit inspection" procedure.

NO

- Check that A/T-20A fuse in engine room junction is installed or not blown.
- Check for open in harness. Repair as necessary and go to "Verification vehicle repair" procedure.

SIGNAL CIRCUIT INSPECTION E00E052A

1. Check signal circuit open inspection
 - 1) Ignition "OFF".
 - 2) Disconnect "ATM SOLENOID VALVE" connector and "PCM" connector.
 - 3) Measure resistance between terminal "3" of the ATM SOLENOID VALVE harness connector and terminal "3" of the PCM harness connector B.

Specification: approx. 0 Ω

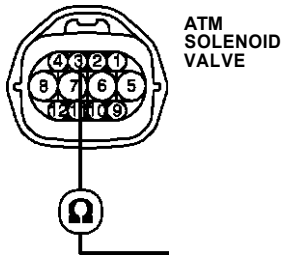

- 3. UD solenoid valve
- 4. 2ND solenoid valve
- 5. A/T battery
- 6. A/T battery
- 7. VFS solenoid valve(+)
- 8. VFS solenoid valve(-)
- 9. DCC solenoid valve
- 11. LR solenoid valve
- 12. OD solenoid valve

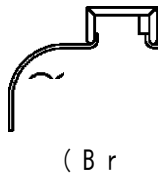

- 3. UD solenoid valve
- 22. LR solenoid valve
- 42. OD solenoid valve
- 43. DCC solenoid valve
- 45. 2ND solenoid valve
- 59. VFS solenoid valve(-)
- 75. VFS solenoid valve(+)



X51150X49148X*x*x15)^3^2^

X71170169168fc7T?)f^Q^2^

r

- 4) Is resistance within specifications?
 - Go to "Check signal circuit short inspection" procedure.
 - Check for open in harness. Repair as necessary and go to "Verification vehicle repair" procedure.

2. Check signal circuit short inspection

- 1) Ignition "OFF".
- 2) Disconnect "ATM SOLENOID VALVE" connector and "PCM" connector.
- 3) Measure resistance between terminal "3" of the ATM SOLENOID VALVE harness and chassis ground.

Specification: Infinite

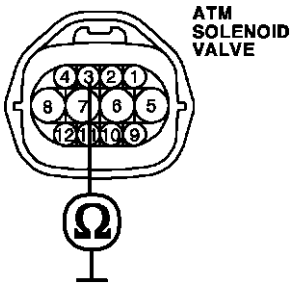

3. UD solenoid valve
4. 2ND solenoid valve
5. A/T battery
6. A/T battery
7. VFS solenoid valve(+)
8. VFS solenoid valve(-)
9. DCC solenoid valve
11. LR solenoid valve
12. OD solenoid valve

4) Is resistance within specifications?

- Go to "Component inspection" procedure.
- Check for short to ground in harness. Repair as necessary and go to "Verification vehicle repair" procedure.

COMPONENT INSPECTION E739B43B

1. CHECK SOLENOID VELVE

- 1) Ignition "OFF".
- 2) Disconnect "ATM SOLENOID VALVE" connector.
- 3) Measure resistance between terminal "3" and terminal "5" of the ATM SOLENOID VALVE harness connector.

Specification: Approximately 2.6-3.4 Q [20°C(68°F)]

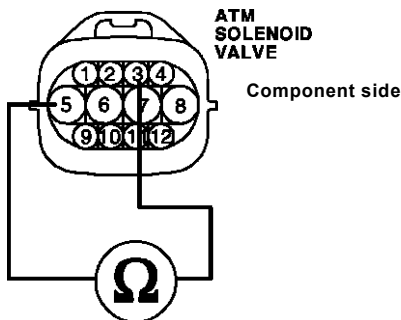

3. UD solenoid valve
4. 2ND solenoid valve
5. A/T battery
6. A/T battery
7. VFS solenoid valve(+)
8. VFS solenoid valve(-)
9. DCC solenoid valve
11. LR solenoid valve
12. OD solenoid valve

4) Is resistance within specification?

YES

- Go to "CHECK PCM" as below.

NO

- Replace UD SOLENOID VALVE as necessary and go to "Verification vehicle repair" procedure.

2. CHECK PCM

1) Connect scantool to data link connector(DLC).

2) Ignition "ON" & Engine "OFF".

3) Select ATM solenoid valve actuator test and operate actuator test.

4) Can you hear operating sound for UD SOLENOID VALVE actuator testing function?

- Go to "Verification vehicle repair" procedure.

NO

- Replace PCM as necessary and go to "Verification vehicle repair" procedure.

ACTUATOR TEST CONDITION

1. IG SWITCH ON
2. TRANSAXLE RANGE SWITCH is normal
3. P RANGE
4. Vehicle Speed Okm/h
5. Throttle position sensor < 1V
6. IDLE SWITCH ON
7. ENGINE RPM 0

VERIFICATION OF VEHICLE REPAIR EB7A.ID4

Refer to DTC P0741.

DTC P0760 SHIFT CONTROL SOLENOID VALVE C CIRCUIT MALFUNCTION

COMPONENT LOCATION ECDAE0DE

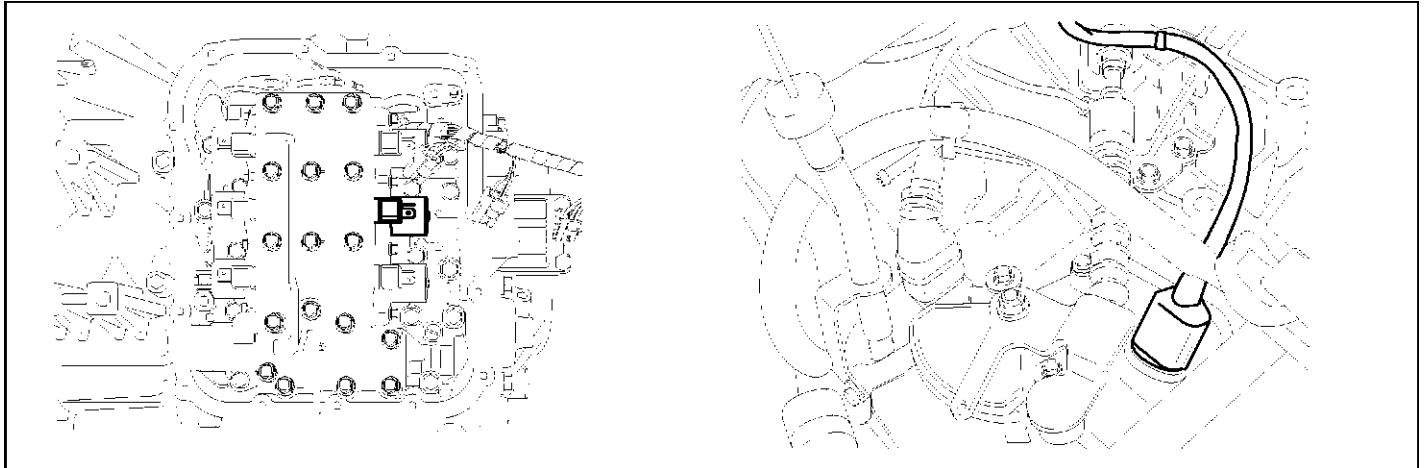

KKCF2131

GENERAL DESCRIPTION EUACW

The Automatic transmission changes the gear position of the transmission by utilizing a combination of clutches and brakes, which are controlled by solenoid valves. This automatic transmission consists of a: LR (Low and Reverse Brake), 2ND (2nd Brake), UD (Under Drive Clutch), OD (Over Drive Clutch), REV (Reverse Clutch), and a RED (Reduction Brake, only for 5 speed transmissions).

The 2ND brake is engaged in the 2nd and 5th gear positions.

DTC DESCRIPTION EF34EC69

The PCM checks the 2ND brake control signal by monitoring the feedback signal from the solenoid valve drive circuit. If an unexpected signal is monitored (for example, high voltage is detected when low voltage is expected, or low voltage is detected when high voltage is expected), the PCM judges that the 2ND brake control solenoid circuit is malfunctioning and sets this code.

DTC DETECTING CONDITION E10CE0BA

Item	Detecting Condition & Fail Safe	Possible cause
DTC Strategy	<ul style="list-style-type: none"> • Check voltage range 	<ul style="list-style-type: none"> • Open or short in circuit • Faulty 2nd SOLENOID VALVE • Faulty PCM
Enable Conditions	<ul style="list-style-type: none"> • Engine state=Run • Engine runtime > 0.5 sees • Battery voltage > 11V and 16 V • Transmission relay state : Relay on • Gear shifting is completed 	
Threshold value	<ul style="list-style-type: none"> • When the PCM detects electric or electronic abnormalness such as short circuit or out of range voltage. 	
Diagnostic Time	<ul style="list-style-type: none"> • More than 5 seconds 	
Fail Safe	<ul style="list-style-type: none"> • Locked in 3rd gear.(Control relay off) 	

SPECIFICATION EEDF6EB3

Refer to DTC P0743.

MONITOR SCANTOOL DATA E401BBA2

1. Connect scantool to data link connector(DLC)
2. Engine "ON".
3. Monitor the "2nd SOL. VALVE" parameter on the scantool.
4. Shift gear position 1st to 2nd.

Specification: 1st gear — 100%, 2nd gear -> 0.0%

1. 2 CUBRENI DATA

```

LSRSU DUTV          B. B  4
UDSO DUTV           0. 0  %
2HDSU_DUTV_____  10  ?.-.?^...
ODSU_DUTV_____   ..JBEifk...
iMy?^t?..?fi^E..?y. £_____
THBOTTLE P. SENSOR  12. 9  %
FLUID TENP. SENSOR  66   ° C
CBK POSITION SNSR     807  rpm
    
```

FIX SCBN FULL PART GBPH HELP

FIG.1)

FIG. 1) 1st gear
FIG. 2) 2nd gear

1. 2 CURRENT DATA

	Lfirsu DUTV	100. 0%
	UDSU DUTV	0. 0 4
a	2NDSU DUTV	0. 0 4
	ODSO DUTV	100. 0%
	SHIFT POSITION	2
	THROTTLE P. SENSOB	12. 9 4
	FLUID TENP. SENSOR	71 °C
	CBK POSITION SNSB	835 rpm

FIX SCBN FULL PART GRPH HELP

FIG.2)

ELQE047A

Does "2nd SOLENOID DUTY " follow the reference data?

- Fault is intermittent caused by poor contact in the sensor's and/or PCM's connector or was repaired and PCM memory was not cleared. Thoroughly check connectors for looseness, poor connection, bending, corrosion, contamination, deterioration or damage. Repair or replace as necessary and go to "Verification vehicle repair" procedure.

- Go to "Terminal & connector inspection " procedure.

TERMINAL & CONNECTOR INSPECTION EBDAZDCF

Refer to DTC P0743.

ATA-122

POWER SUPPLY CIRCUIT INSPECTION E,76A,7C

1. Disconnect "ATM SOLENOID VALVE" connector.
2. Measure voltage between terminal "5" of the sensor harness connector and chassis ground.
3. Turn ignition switch OFF -> ON.

Specification: 12V is measured only for approx. 0.5sec

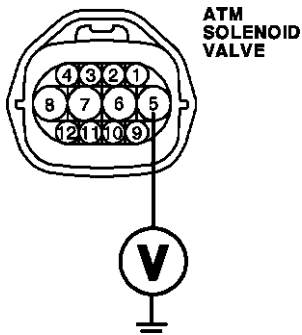

- 3.UD solenoid valve
- 4.2ND solenoid valve
- 5. A/T battery
- 6. A/T battery
- 7. VFS solenoid valve(+)
- 8. VFS solenoid valve(-)
- 9. DCC solenoid valve
- 11. LR solenoid valve
- 12.0D solenoid valve

EKRF717A

4. Is voltage within specifications?

YES

- Go to "Signal circuit inspection" procedure.

NO

- Check that A/T-20A fuse in engine room junction is installed or not blown.
- Check for open in harness. Repair as necessary and go to "Verification vehicle repair" procedure.

SIGNAL CIRCUIT INSPECTION E223396A

1. Check signal circuit open inspection
 - 1) Ignition "OFF".
 - 2) Disconnect "ATM SOLENOID VALVE" connector and "PCM" connector.
 - 3) Measure resistance between terminal "4" of the ATM SOLENOID VALVE harness connector and terminal "45" of the PCM harness connector B.

Specification: approx. 0 Ω

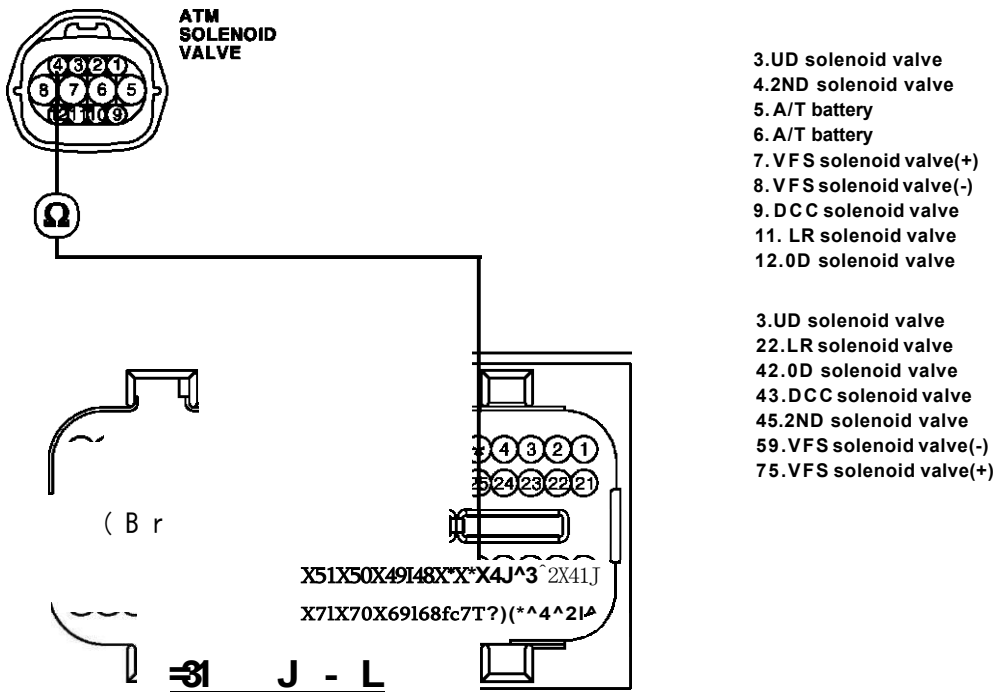

EKRF718A

- 4) Is resistance within specifications?
 - Go to "Check signal circuit short inspection" procedure.
 - Check for open in harness. Repair as necessary and go to "Verification vehicle repair" procedure.

ATA-124

2. Check signal circuit short inspection

- 1) Ignition "OFF".
- 2) Disconnect "ATM SOLENOID VALVE" connector and "PCM" connector.
- 3) Measure resistance between terminal "4" of the ATM SOLENOID VALVE harness and chassis ground.

Specification: Infinite

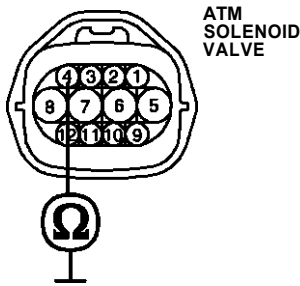

- 3.UD solenoid valve
- 4.2ND solenoid valve
- 5. A/T battery
- 6. A/T battery
- 7. VFS solenoid valve(+)
- 8. VFS solenoid valve(-)
- 9. DCC solenoid valve
- 11. LR solenoid valve
- 12.0D solenoid valve

EKRF718B

4) Is resistance within specifications?

YES

- Go to "Component inspection" procedure.

NO

- Check for short to ground in harness. Repair as necessary and go to "Verification vehicle repair" procedure.

COMPONENT INSPECTION E00FFDBB

1. CHECK SOLENOID VELVE

- 1) Ignition "OFF".
- 2) Disconnect "ATM SOLENOID VALVE" connector.
- 3) Measure resistance between terminal "4" and terminal "5" of the ATM SOLENOID VALVE harness connector.

Specification: Approximately 2.6-3.4 Q [20°C(68°F)]

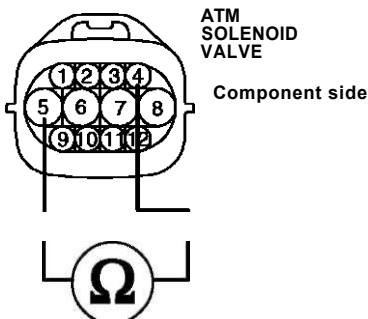

- 3.UD solenoid valve
- 4.2ND solenoid valve
- 5. A/T battery
- 6. A/T battery
- 7. VFS solenoid valve(+)
- 8. VFS solenoid valve(-)
- 9. DCC solenoid valve
- 11. LR solenoid valve
- 12.0D solenoid valve

EKRF718C

4) Is resistance within specification?

YES

- Go to "CHECK PCM" as below.

NO

- Replace 2nd SOLENOID VALVE as necessary and go to "Verification vehicle repair" procedure.

2. CHECK PCM

1) Connect scantool to data link connector(DLC).

2) Ignition "ON" & Engine "OFF".

3) Select A/T solenoid valve actuator test and operate actuator test.

4) Can you hear operating sound for 2nd SOLENOID VALVE actuator testing function?

- Go to "Verification vehicle repair" procedure.

NO

- Replace PCM as necessary and go to "Verification vehicle repair" procedure.

ACTUATOR TEST CONDITION

1. IG SWITCH ON
2. TRANSAXLE RANGE SWITCH is normal
3. P RANGE
4. Vehicle Speed 0km/h
5. Throttle position sensor < 1V
6. IDLE SWITCH ON
7. ENGINE RPM 0

VERIFICATION OF VEHICLE REPAIR EBABESBE

Refer to DTC P0741.

DTC P0765 SHIFT CONTROL SOLENOID VALVE D CIRCUIT MALFUNCTION

COMPONENT LOCATION E6CCAC16

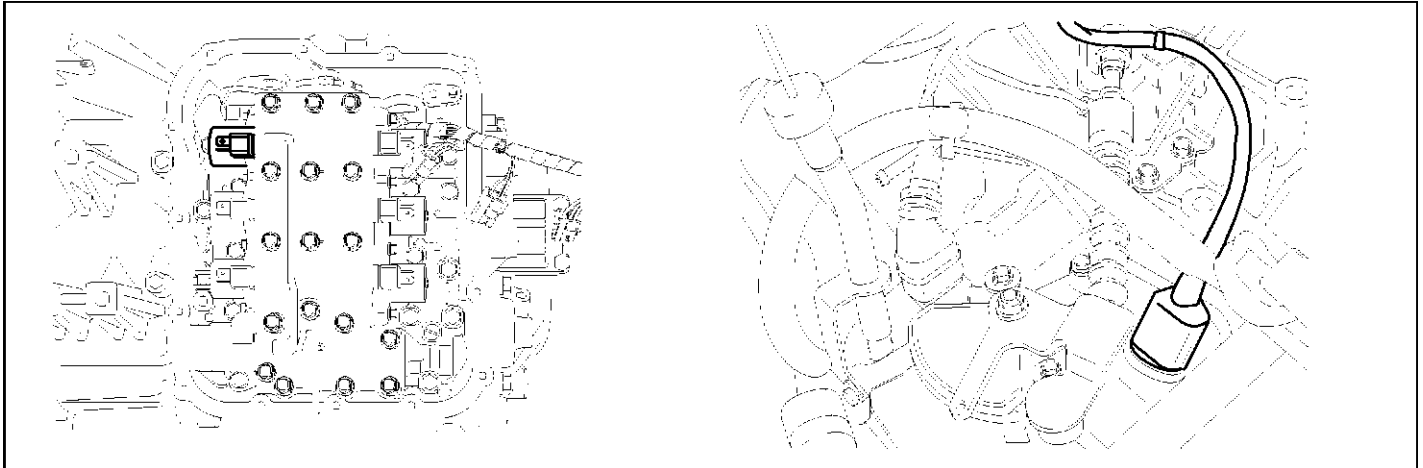

KKCF213J

GENERAL DESCRIPTION EE446DA1

The Automatic transmission changes the gear position of the transmission by utilizing a combination of clutches and brakes, which are controlled by solenoid valves. This automatic transmission consists of a: LR (Low and Reverse Brake), 2ND (2nd Brake), UD (Under Drive Clutch), OD (Over Drive Clutch), REV (Reverse Clutch), and a RED (Reduction Brake, only for 5 speed transmissions).

The OD clutch is engaged in the 3rd/4th/5th gear positions.

DTC DESCRIPTION E01063D7

The PCM checks the OD clutch control signal by monitoring the feedback signal from the solenoid valve drive circuit. If an unexpected signal is monitored (for example, high voltage is detected when low voltage is expected, or low voltage is detected when high voltage is expected), the PCM judges that the OD clutch control solenoid circuit is malfunctioning and sets this code.

DTC DETECTING CONDITION ECCC479F

Item	Detecting Condition & Fail Safe	Possible cause
DTC Strategy	<ul style="list-style-type: none"> • Check voltage range 	<ul style="list-style-type: none"> • Open or short in circuit • Faulty OD SOLENOID VALVE • Faulty PCM
Enable Conditions	<ul style="list-style-type: none"> • Engine state=Run • Engine runtime > 0.5 sees • Battery voltage > 11V and 16 V • Transmission relay state : Relay on • Gear shifting is completed 	
Threshold value	<ul style="list-style-type: none"> • When the PCM detects electric or electronic abnormalness such as short circuit or out of range voltage. 	
Diagnostic Time	<ul style="list-style-type: none"> • More than 5 seconds 	
Fail Safe	<ul style="list-style-type: none"> • Locked in 3rd gear.(Control relay off) 	

SPECIFICATION EA9ADFFF

Refer to DTC P0743.

MONITOR SCANTOOL DATA ED2570A8

1. Connect scantool to data link connector(DLC).
2. Engine "ON".
3. Monitor the "OD SOL. VALVE" parameter on the scantool.
4. Shift gear position 2nd to 3rd.

Specification: 2nd gear — 100%, 3rd gear -> 0.0%

1. 2 CURRENT DATA

	TCC SOLENOID DUTV	0.0 %
*	LR SOLENOID DUTV	100.0%
x	UD SOLENOID DUTV	0.0 %
x	2ND SOLENOID DUTV	0.0 %
x	OD SOLENOID DUTV	100.0%
x	SHIFT POSITION	2 GEAE
x	SELECT LEUER SU.	D
	ENGINE TORQUE	14.9 X

FIX SCR N FULL PART GBPH HELP

FIG.1)

FIG. 1) 2nd gear

FIG. 2) 3rd gear

1. 2 CURRENT DATA

	LfIRSO DUTM	100.0%
	UDSU DUTV	0.0 %4
	ODSU DUTV	0.0 %
	ISHIFT POSITION	3
	THROTTLE P. SENSOR	16.1 %
	FLUID TEMP.SENSOR	72 °C
	CRK POSITION SNSR	1789 rp◀

FIX SCR N FULL PART GRPH HELP

FIG.2)

Does "OD SOLENOID DUTY " follow the reference data?

- Fault is intermittent caused by poor contact in the sensor's and/or PCM's connector or was repaired and PCM memory was not cleared. Thoroughly check connectors for looseness, poor connection, bending, corrosion, contamination, deterioration or damage. Repair or replace as necessary and go to "Verification vehicle repair" procedure.

- Go to "Terminal & connector inspection " procedure.

TERMINAL & CONNECTOR INSPECTION EDSDB™

Refer to DTC P0743.

POWER SUPPLY CIRCUIT INSPECTION EOC16,,D

Refer to DTC P0755.

SIGNAL CIRCUIT INSPECTION EEDB6DC3

1. Check signal circuit open inspection

- 1) Ignition "OFF".

- 2) Disconnect "ATM SOLENOID VALVE" connector and "PCM" connector.
- 3) Measure resistance between terminal "12" of the ATM SOLENOID VALVE harness connector and terminal "42" of the PCM harness connector B.

Specification: approx. 0 Ω

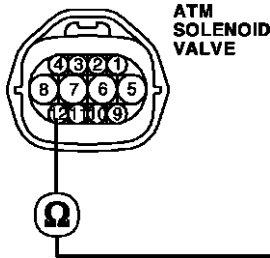

- 3.UD solenoid valve
- 4.2ND solenoid valve
- 5. A/T battery
- 6. A/T battery
- 7. VFS solenoid valve(+)
- 8. VFS solenoid valve(-)
- 9.DCC solenoid valve
- 11. LR solenoid valve
- 12.0D solenoid valve

- 3.UD solenoid valve
- 22.LR solenoid valve
- 42.0D solenoid valve
- 43.DCC solenoid valve
- 45.2ND solenoid valve
- 59.VFS solenoid valve(-)
- 75.VFS solenoid valve(+)

nJ

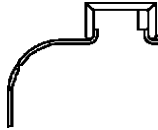

1—|)

• r

EKRF719B

- 4) Is resistance within specifications?

- Go to "Check signal circuit short inspection" procedure.
- Check for open in harness. Repair as necessary and go to "Verification vehicle repair" procedure.

2. Check signal circuit short inspection

- 1) Ignition "OFF".
- 2) Disconnect "ATM SOLENOID VALVE" connector and "PCM" connector.
- 3) Measure resistance between terminal "12" of the ATM SOLENOID VALVE harness and chassis ground.

Specification: Infinite

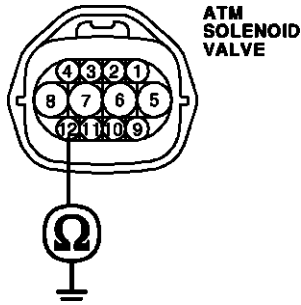

- 3.UD solenoid valve
- 4.2ND solenoid valve
- 5. A/T battery
- 6. A/T battery
- 7. VFS solenoid valve(+)
- 8. VFS solenoid valve(-)
- 9. DCC solenoid valve
- 11. LR solenoid valve
- 12.0D solenoid valve

EKRF719C

4) Is resistance within specifications?

YES

- Go to "Component inspection" procedure.

NO

- Check for short to ground in harness. Repair as necessary and go to "Verification vehicle repair" procedure.

COMPONENT INSPECTION EF84AD47

1. CHECK SOLENOID VELVE

- 1) Ignition "OFF".
- 2) Disconnect "ATM SOLENOID VALVE" connector.
- 3) Measure resistance between terminal "12" and terminal "5" of the ATM SOLENOID VALVE harness connector.

Specification: Approximately 2.6-3.4 £3 [20°C(68°F)]

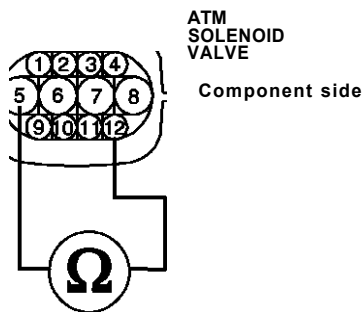

- 3.UD solenoid valve
- 4.2ND solenoid valve
- 5. A/T battery
- 6. A/T battery
- 7. VFS solenoid valve(+)
- 8. VFS solenoid valve(-)
- 9. DCC solenoid valve
- 11. LR solenoid valve
- 12.0D solenoid valve

4) Is resistance within specification?

- Go to "CHECK PCM" as below.

NO

- Replace OD SOLENOID VALVE as necessary and go to "Verification vehicle repair" procedure.

2. CHECK PCM

- 1) Connect scantool to data link connector(DLC).
- 2) Ignition "ON" & Engine "OFF".
- 3) Select A/T solenoid valve actuator test and operate actuator test.
- 4) Can you hear operating sound for OD SOLENOID VALVE actuator testing function?

YES

- Go to "Verification vehicle repair" procedure.

NO

- Replace PCM as necessary and go to "Verification vehicle repair" procedure.

ACTUATOR TEST CONDITION

1. IG SWITCH ON
2. TRANSAXLE RANGE SWITCH is normal
3. P RANGE
4. Vehicle Speed 0km/h
5. Throttle position sensor < 1V
6. IDLE SWITCH ON
7. ENGINE RPM 0

VERIFICATION OF VEHICLE REPAIR E,B07,67

Refer to DTC P0741.

DTC P0770 SHIFT CONTROL SOLENOID VALVE E CIRCUIT MALFUNCTION

COMPONENT LOCATION EFEE94C2

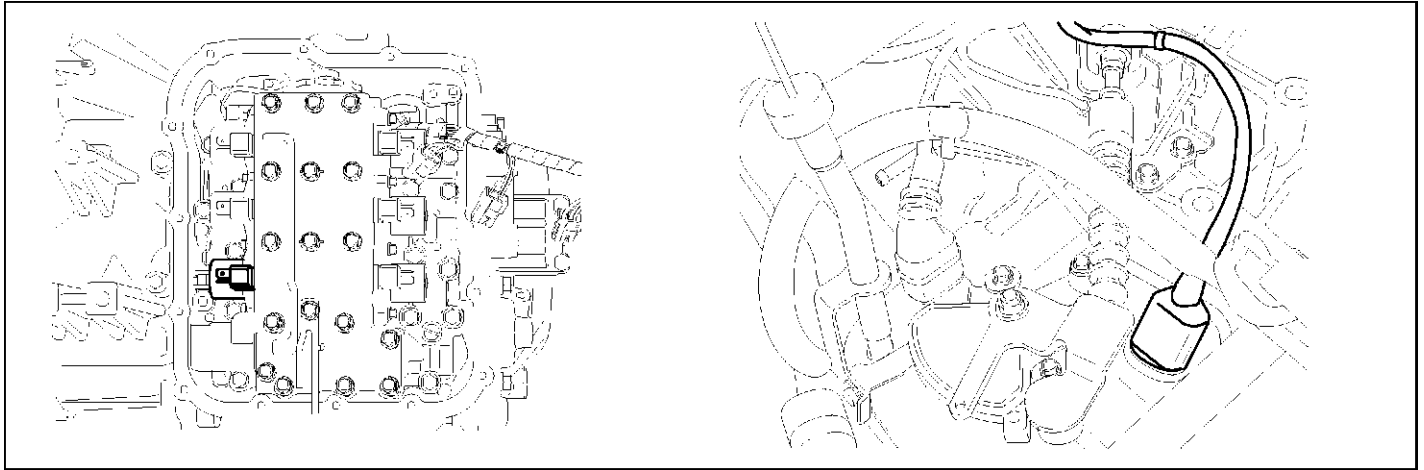

KKCF213K

GENERAL DESCRIPTION EEB21C02

The Automatic transmission changes the gear position of the transmission by utilizing a combination of clutches and brakes, which are controlled by solenoid valves. This automatic transmission consists of a: LR (Low and Reverse Brake), 2ND (2nd Brake), UD (Under Drive Clutch), OD (Over Drive Clutch), REV (Reverse Clutch), and a RED (Reduction Brake, only for 5 speed transmissions).

The RED clutch is engaged in the P/R/N/1 st/2nd/3rd gear positions.

DTC DESCRIPTION EC9FFFD4

The PCM checks the RED clutch control signal by monitoring the feedback signal from the solenoid valve drive circuit. If an unexpected signal is monitored (for example, high voltage is detected when low voltage is expected, or low voltage is detected when high voltage is expected), the PCM judges that the RED clutch control solenoid circuit is malfunctioning and sets this code.

DTC DETECTING CONDITION E5DDA986

Item	Detecting Condition & Fail Safe	Possible cause
DTC Strategy	<ul style="list-style-type: none"> • Check voltage range 	<ul style="list-style-type: none"> • Open or short in circuit • Faulty RED SOLENOID VALVE • Faulty PCM
Enable Conditions	<ul style="list-style-type: none"> • Engine state=Run • Engine runtime > 0.5 sees • Battery voltage > 11V and 16 V • Transmission relay state : Relay on • Gear shifting is completed 	
Threshold value	<ul style="list-style-type: none"> • When the PCM detects electric or electronic abnormalness such as short circuit or out of range voltage. 	
Diagnostic Time	<ul style="list-style-type: none"> • More than 5 seconds 	
Fail Safe	<ul style="list-style-type: none"> • Locked in 3rd gear.(Control relay off) 	

SPECIFICATION EAD2BC11

Refer to DTC P0743.

MONITOR SCANTOOL DATA ED7AF1EE

1. Connect scantool to data link connector(DLC).
2. Engine "ON".
3. Monitor the "RED SOL. VALVE" parameter on the scantool.
4. Shift gear position 3rd to 4th.

Specification: 3rd gear — 0%, 4th gear — 100%

Does "RED SOLENOID DUTY " follow the reference data?

YES

- Fault is intermittent caused by poor contact in the sensor's and/or PCM's connector or was repaired and PCM memory was not cleared. Thoroughly check connectors for looseness, poor connection, bending, corrosion, contamination, deterioration or damage. Repair or replace as necessary and go to "Verification vehicle repair" procedure.

NO

- Go to "Terminal & connector inspection " procedure.

TERMINAL & CONNECTOR INSPECTION E^U C E A

Refer to DTC P0743.

POWER SUPPLY CIRCUIT INSPECTION EOC54DD,

Refer to DTC P0750.

SIGNAL CIRCUIT INSPECTION EFBFF4A0

1. Check signal circuit open inspection
 - 1) Ignition "OFF".
 - 2) Disconnect "ATM SOLENOID VALVE" connector and "PCM" connector.
 - 3) Measure resistance between terminal "10" of the ATM SOLENOID VALVE harness connector and terminal "44" of the PCM harness connector B.

Specification: approx. 0 £3

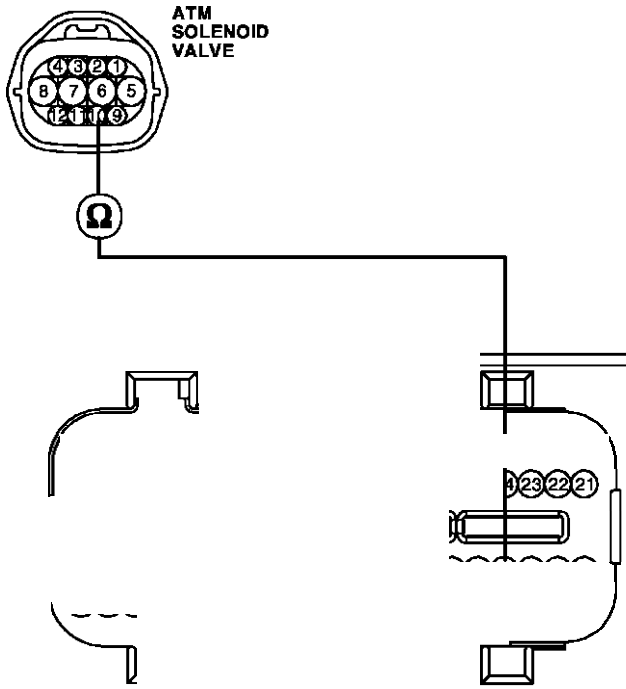

- 3.UD solenoid valve
- 4.2ND solenoid valve
- 5. A/T battery
- 6. A/T battery
- 7. VFS solenoid valve(+)
- 8. VFS solenoid valve(-)
- 9. DCC solenoid valve
- 10. RED solenoid valve
- 11. LR solenoid valve
- 12.0D solenoid valve

- 3.UD solenoid valve
- 22.LR solenoid valve
- 42.0D solenoid valve
- 43.DCC solenoid valve
- 44.RED solenoid valve
- 45.2ND solenoid valve
- 59.VFS solenoid valve(-)
- 75.VFS solenoid valve(+)

4) Is resistance within specifications?

- Go to "Check signal circuit short inspection" procedure.
- Check for open in harness. Repair as necessary and go to "Verification vehicle repair" procedure.

2. Check signal circuit short inspection

- 1) Ignition "OFF".
- 2) Disconnect "ATM SOLENOID VALVE" connector and "PCM" connector.
- 3) Measure resistance between terminal "10" of the ATM SOLENOID VALVE harness and chassis ground.

Specification: Infinite

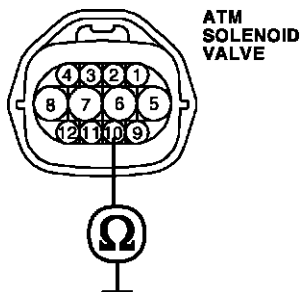

- 3.UD solenoid valve
- 4.2ND solenoid valve
- 5. A/T battery
- 6. A/T battery
- 7. VFS solenoid valve(+)
- 8. VFS solenoid valve(-)
- 9. DCC solenoid valve
- 10. RED solenoid valve
- 11. LR solenoid valve
- 12.0D solenoid valve

ATA-134

4) Is resistance within specifications?

YES

- Go to "Component inspection" procedure.

NO

- Check for short to ground in harness. Repair as necessary and go to "Verification vehicle repair" procedure.

COMPONENT INSPECTION EF6DE69A

1. CHECK SOLENOID VALVE

- 1) Ignition "OFF".
- 2) Disconnect "ATM SOLENOID VALVE" connector.
- 3) Measure resistance between terminal "6" and terminal "10" of the ATM SOLENOID VALVE harness connector.

Specification: Approximately 2.6-3.4 Q [20°C(68°F)]

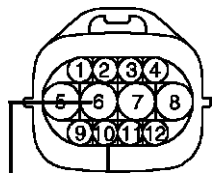

**ATM
SOLENOID
VALVE**

Component side

- 1. solenoid valve
- 2. 2ND solenoid valve
- 3. A/T battery
- 4. A/T battery
- 5. VFS solenoid valve(+)
- 6. VFS solenoid valve(-)
- 7. DCC solenoid valve
- 8. RED solenoid valve
- 9. LR solenoid valve
- 10. D solenoid valve



EKRF720D

4) Is resistance within specification?

YES

- Go to "CHECK PCM" as below.

NO

- Replace RED SOLENOID VALVE as necessary and go to "Verification vehicle repair" procedure.

2. CHECK PCM

- 1) Connect scantool to data link connector(DLC).
- 2) Ignition "ON" & Engine "OFF".
- 3) Select A/T solenoid valve actuator test and operate actuator test.
- 4) Can you hear operating sound for RED SOLENOID VALVE actuator testing function?

YES

- Go to "Verification vehicle repair" procedure.

NO

- Replace PCM as necessary and go to "Verification vehicle repair" procedure.

ACTUATOR TEST CONDITION

1. IG SWITCH ON
2. TRANSAXLE RANGE SWITCH is normal
3. P RANGE
4. Vehicle Speed 0km/h
5. Throttle position sensor < 1V
6. IDLE SWITCH ON
7. ENGINE RPM 0

VERIFICATION OF VEHICLE REPAIR EFCDBB,,

Refer to DTC P0741.

DTC P0885 A/T RELAY CIRCUIT MALFUNCTION

COMPONENT LOCATION EB271BEA

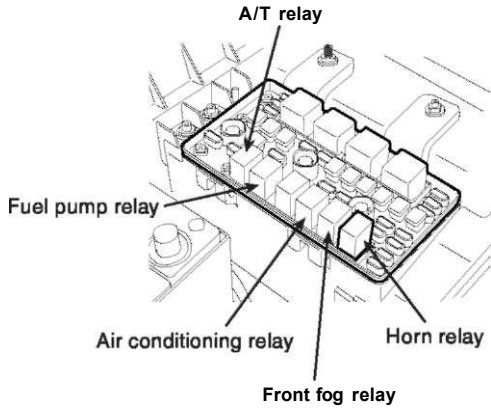

EKRF721F

GENERAL DESCRIPTION EEF3DE40

The automatic transmission supplies power to the solenoid valves by way of a control relay. When the PCM sets the relay to ON, the relay operates and the battery power is supplied to all the solenoid valves. When the PCM sets the relay to OFF, all solenoid valve power is shut off and the transmission is held in the 3rd gear position. (Fail Safe Mode)

DTC DESCRIPTION EA3659D6

The PCM checks the A/T control relay signal by monitoring the control signal. If, after the ignition key is turned on, an unexpected voltage value, which is quite a bit lower than battery voltage, is detected, the PCM sets this code. This code can also be set when the battery power fuse in the ignition switch has been shorted.

DTC DETECTING CONDITION EF43ED8D

Item	Detecting Condition & Fail Safe	Possible cause
DTC Strategy	<ul style="list-style-type: none"> • Check voltage range 	<ul style="list-style-type: none"> • Open or short in circuit • Faulty A/T control relay • Faulty PCM
Enable Conditions	<ul style="list-style-type: none"> • Engine state=Run • Engine runtime > 0.5 sees • Battery voltage > 11V and 16 V • Transmission relay state : Relay on • Gear shifting is completed 	
Threshold value	<ul style="list-style-type: none"> • PCM detects abnormally low voltage 	
Diagnostic Time	<ul style="list-style-type: none"> • 2.375 second 	
Fail Safe	<ul style="list-style-type: none"> • Locked in 3rd gear.(Control relay off) 	

MONITOR SCANTOOL DATA ECAD5F88

1. Connect scantool to data link connector(DLC).
2. Ignition "ON" & Engine "OFF".
3. Monitor the "A/T CON. RELAY VOLT" parameter on the scantool.

Specification : Approx. B+

1.2 CURRENT DATA

A^T HELAV UOLT	14.3 0
TRANSAXLE RANGE SU	P, N
SHIFT POSITION	N, P, R
BOOST PRESS.SNSR	3 kPa
HOLD/STD SWITCH	STD
A/C SWITCH	OFF
CLOSED TP SWITCH	ON
STOP LIGHT SWITCH	OFF
FIX SCRN FULL PART GRPH HELP	

4. Is A/T RELAY VOLT within specifications?

- Fault is intermittent caused by poor contact in the sensor's and/or PCM's connector or was repaired and PCM memory was not cleared. Thoroughly check connectors for looseness, poor connection, bending, corrosion, contamination, deterioration or damage. Repair or replace as necessary and go to "Verification vehicle repair" procedure.
- Go to "Terminal & connector inspection" procedure.

TERMINAL & CONNECTOR INSPECTION EBB4.,BD

1. Many malfunctions in the electrical system are caused by poor harness and terminals. Faults can also be caused by interference from other electrical systems, and mechanical or chemical damage.
2. Thoroughly check connectors for looseness, poor connection, bending, corrosion, contamination, deterioration, or damage.
3. Has a problem been found?

YES

- Repair as necessary and then go to "Verification of vehicle repair" procedure.

NO

- Replace the PCM.

VERIFICATION OF VEHICLE REPAIR E1BE7D..

After a repair, it is essential to verify that the fault has been corrected.

1. Connect scan tool and select "Diagnostic Trouble Codes(DTCs)" mode.
2. Using a scantool, Clear DTC.
3. Operate the vehicle within DTC Enable conditions in General information.
4. Are any DTCs present ?

YES

- Go to the applicable troubleshooting procedure.

NO

- System performing to specification at this time.

DTC P0890 AT RELAY - LOW CIRCUIT

COMPONENT LOCATION ED011A75

Refer to DTC P0885.

GENERAL DESCRIPTION E3A6CF11

The automatic transmission supplies power to the solenoid valves by way of a control relay. When the PCM sets the relay to ON, the relay operates and the battery power is supplied to all the solenoid valves. When the PCM sets the relay to OFF, all solenoid valve power is shut off and the transmission is held in the 3rd gear position. (Fail Safe Mode)

DTC DESCRIPTION E42E054A

The PCM checks the A/T control relay signal by monitoring the control signal. If, the voltage applied to A/T solenoids is lower than 0.5V, the PCM sets this code.

DTC DETECTING CONDITION EBEA54F8

Item	Detecting Condition & Fail Safe	Possible cause
DTC Strategy	<ul style="list-style-type: none"> • Check voltage range 	<ul style="list-style-type: none"> • Open or short in circuit • Faulty A/T control relay • Faulty PCM
Enable Conditions	<ul style="list-style-type: none"> • Engine state * Power off relay or engine shutdown process • Battery voltage > 11V and < 16V • A/T power relay is enabled • No TCM power relay diag fail 	
Threshold value	<ul style="list-style-type: none"> • Voltage applied to A/T solenoids < = 0.5 V 	
Diagnostic Time	<ul style="list-style-type: none"> • 2 seconds 	
Fail Safe	<ul style="list-style-type: none"> • Locked in 3rd gear.(Control relay off) 	

MONITOR SCANTOOL DATA EEF3E39C

Refer to DTC P0885.

TERMINAL & CONNECTOR INSPECTION E,FDCCA0

Refer to DTC P0885.

ATA-140

POWER SUPPLY CIRCUIT INSPECTION EA,FFB4.

1. Ignition "ON" & Engine "OFF".
2. Disconnect the "A/T CONTROL RELAY" connector.
3. Measure the voltage between the power terminal of the "A/T CONTROL RELAY" in the engine room relay box and chassis ground.

Specification : Approx. B+

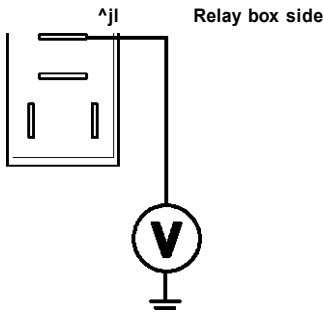

EKRF721B

4. Is voltage within specifications?

YES

- Go to "Signal circuit inspection" procedure.

NO

- Check that A/T-20A fuse in engine room junction is installed or not blown.
- Check for Open in harness. Repair as necessary and go to "Verification vehicle repair" procedure.

SIGNAL CIRCUIT INSPECTION EDBFCD5B

1. CHECK A/T control relay harness
 - 1) Ignition "OFF".
 - 2) Disconnect the "ATM CONTROL RELAY" connector.
 - 3) Measure the voltage between terminal "60" of the "PCM" harness connector A and chassis ground.
 - 4) Turn ignition switch OFF -> ON.

Specification: 12V is measured only for approx. 0.5sec

5) Is voltage within specifications?

- Go to "Check supplying power to solenoid valve" procedure.
- Check for open in harness. Repair as necessary and go to "Verification vehicle repair" procedure
- If signal circuit is OK, Substitute with a known-good PCM and check for proper operation. If the problem is corrected, replace PCM and then go to "Verification of vehicle repair" procedure.

2. CHECK supplying power to solenoid valve harness

- 1) Ignition "OFF".
- 2) Disconnect the "ATM CONTROL RELAY" and PCM connector.
- 3) Measure the resistance between the terminal shown below of the "A/T CONTROL RELAY" in the engine room relay box and terminal "20" of the PCM harness connector A.

Specification : Approx. 0 Ω

Relay box side

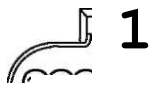

20. Battery voltage

3 Ω 3E



4) Is resistance within specifications?

- Go to "Ground circuit inspection" procedure.
- Check for open in harness. Repair as necessary and go to "Verification vehicle repair" procedure.

ATA-142

GROUND CIRCUIT INSPECTION E8ED4B45

1. Ignition "OFF".
2. Disconnect "A/T CONTROL RELAY" connector.
3. Measure the resistance between the terminal shown below of the "A/T CONTROL RELAY" in the engine room relay box and chassis ground.

Specification : Approx. 0 Ω

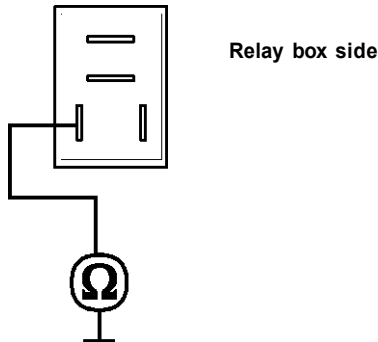

EKRF721E

4. Is resistance within specifications?

YES

- Go to "Component inspection" procedure.

NO

- Check for open in harness. Repair as necessary and go to "Verification vehicle repair" procedure.

COMPONENT INSPECTION E5FD68F0

1. Ignition "OFF".
2. Remove "A/T CONTROL RELAY"
3. Measure the resistance between each terminal of the sensor.

Specification: ∞ except between those two terminals below

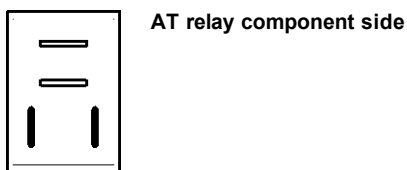

EKRF721G

4. Is resistance within specification?

YES

- Thoroughly check connectors for looseness, poor connection, bending, corrosion, contamination, deterioration, or damage. Repair or replace as necessary and then go to "Verification of vehicle repair" procedure.

NO

- Replace ATM CONTROL RELAY and then go to "Verification of vehicle repair" procedure.

VERIFICATION OF VEHICLE REPAIR EDSEIDTS

Refer to DTC P0885.

DTC P0891 AT RELAY - OPEN CIRCUIT

COMPONENT LOCATION EF9C2B4C

Refer to DTC P0890.

GENERAL DESCRIPTION E75AE183

The automatic transmission supplies power to the solenoid valves by way of a control relay. When the PCM sets the relay to ON, the relay operates and the battery power is supplied to all the solenoid valves. When the PCM sets the relay to OFF, all solenoid valve power is shut off and the transmission is held in the 3rd gear position. (Fail Safe Mode)

DTC DESCRIPTION E75B8DC5

The PCM checks the A/T control relay signal by monitoring the control signal. If, the voltage applied to A/T solenoids is higher than 20V, the PCM sets this code.

DTC DETECTING CONDITION EDAE6676

Item	Detecting Condition & Fail Safe	Possible cause
DTC Strategy	<ul style="list-style-type: none"> • Check voltage range 	<ul style="list-style-type: none"> • Open or short in circuit • Faulty A/T control relay • Faulty PCM
Enable Conditions	<ul style="list-style-type: none"> • Engine state + Power off relay or engine shutdown process • Engine runtime > 0.5 sees • Battery voltage > 11V and 16 V • Transmission relay state : Relay on • Gear shifting is completed 	
Threshold value	<ul style="list-style-type: none"> • Voltage applied to A/T solenoids > = 20 V 	
Diagnostic Time	<ul style="list-style-type: none"> • 2 seconds 	
Fail Safe	<ul style="list-style-type: none"> • Locked in 3rd gear.(Control relay off) 	

MONITOR SCANTOOL DATA E0244AE5

Refer to DTC P0890.

TERMINAL & CONNECTOR INSPECTION ED1DB,5A

Refer to DTC P0890.

POWER SUPPLY CIRCUIT INSPECTION ECOBUF1

Refer to DTC P0890.

SIGNAL CIRCUIT INSPECTION E4004A6C

Refer to DTC P0890.

GROUND CIRCUIT INSPECTION E3B90CD5

Refer to DTC P0890.

AUTOMATIC TRANSAXLE SYSTEM

ATA-145

COMPONENT INSPECTION EA91F2BD

Refer to DTC P0890.

VERIFICATION OF VEHICLE REPAIR EEAE,7E,

Refer to DTC P0890.

AUTOMATIC TRANSAXLE

COMPONENTS(I) E22DC9E6

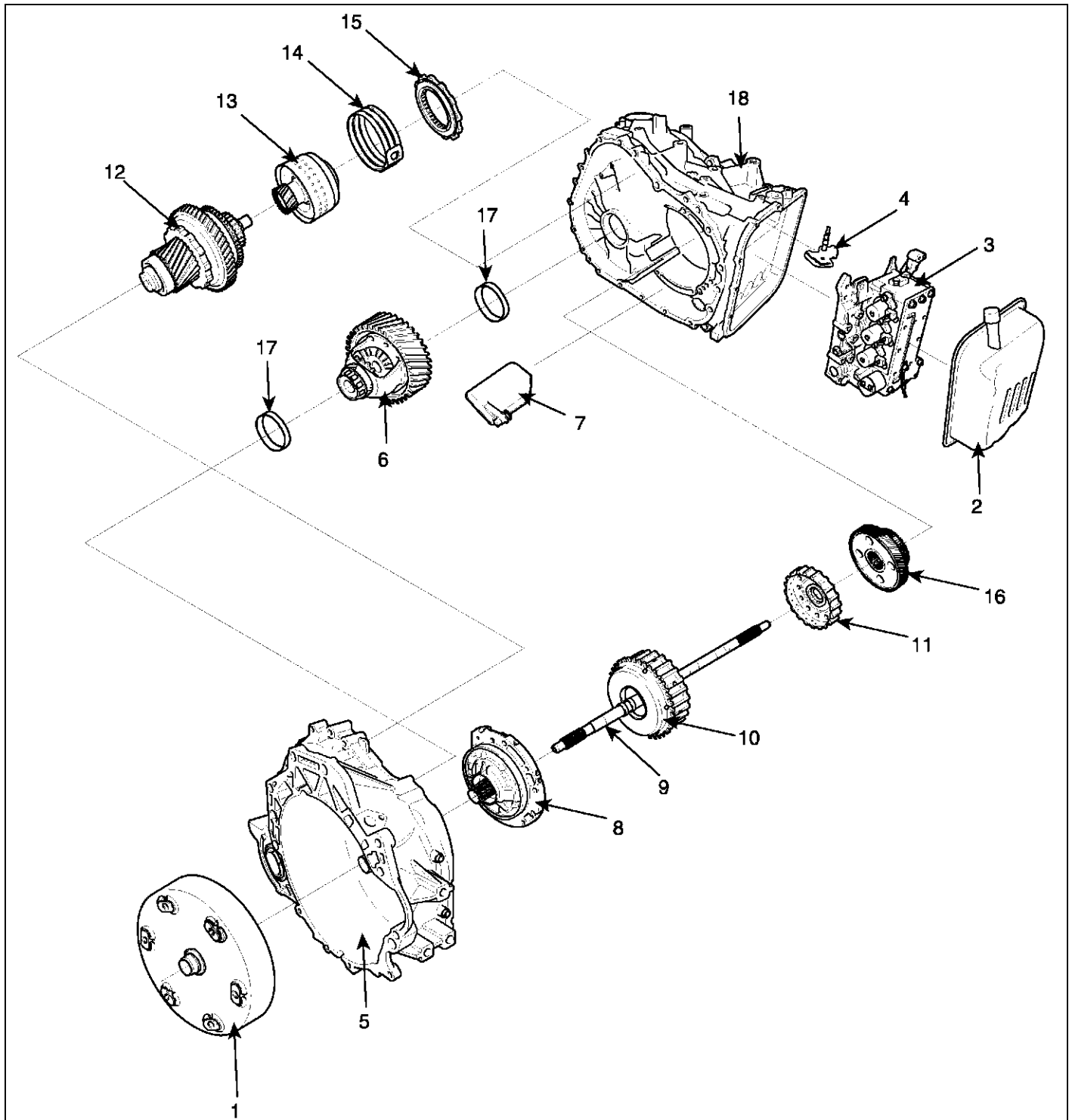

- 1. Torque converter
- 2. Valve body cover
- 3. Valve body assembly
- 4. Manual control shaft assembly
- 5. Converter housing
- 6. Differential assembly

- 7. Main oil filter
- 8. Oil pump
- 9. Input shaft
- 10. Underdrive clutch assembly
- 11. Underdrive clutch hub
- 12. Direct planetary carrier assembly

- 13. Direct clutch assembly
- 14. Reduction brake bend
- 15. One way clutch
- 16. Transfer drive gear
- 17. Differential bearing race
- 18. Transaxle case

COMPONENTS(2)

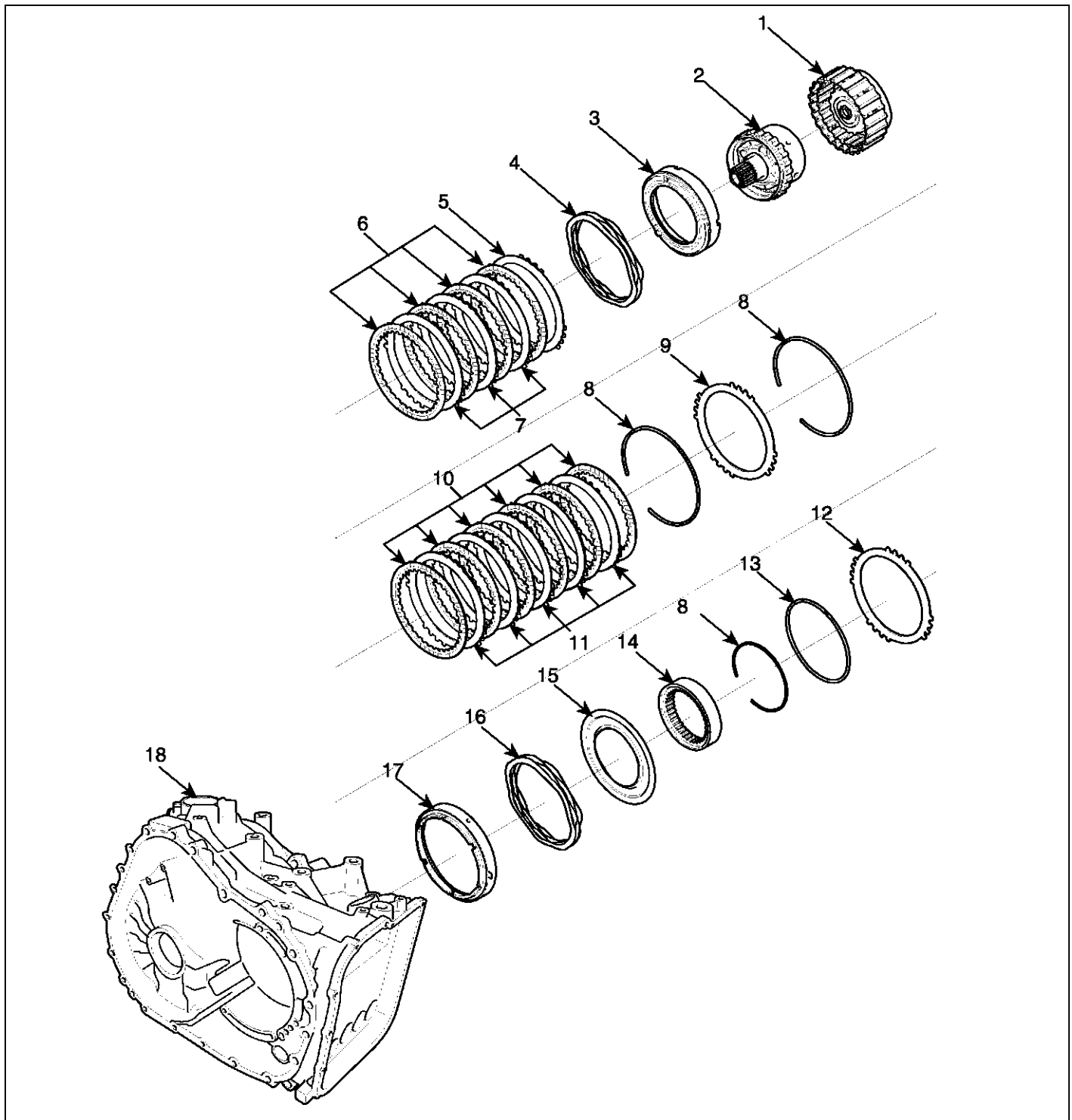

- | | | |
|-----------------------------|--------------------------------------|-------------------------------------|
| 1. Reverse sun gear | 7. 2nd brake plates | 13. Wave spring |
| 2. Planetary gear assembly | 8. Snap ring | 14. Oway clutch inner race |
| 3. 2nd brake retainer | 9. Brake reaction plate | 15. Brake spring retainer |
| 4. 2nd brake return spring | 10. Brake discs | 16. Low&Reverse brake return spring |
| 5. 2nd brake pressure plate | 11. Brake plates | 17. Low&Reverse brake piston |
| 6. 2nd brake discs | 12. Low&Reverse brake pressure plate | 18. Transaxle case |

REMOVAL E4DEAFF0

A CAUTION

- Use fender covers to avoid damaging painted surfaces.
- To avoid damage, unplug the wiring connectors carefully while holding the connector portion.

LjJ NOTE

- Mark all wiring and hoses to avoid misconnection.
- Turn the crankshaft pulley so that the No. 1 piston is at top dead center. (See "EM" group)

1. Disconnect the negative terminal from the battery.
2. Remove the engine cover.
3. Remove the air duct.
4. Remove the intake air hose and air cleaner assembly.
 - 1) Disconnect the AFS connector.
 - 2) Disconnect the breather hose from air cleaner hose.
 - 3) Disconnect the PCM connectors. (See FL group)
 - 4) Remove the intake air hose and air cleaner (A).

5. Remove the front wheels.
6. Remove the under cover(A).

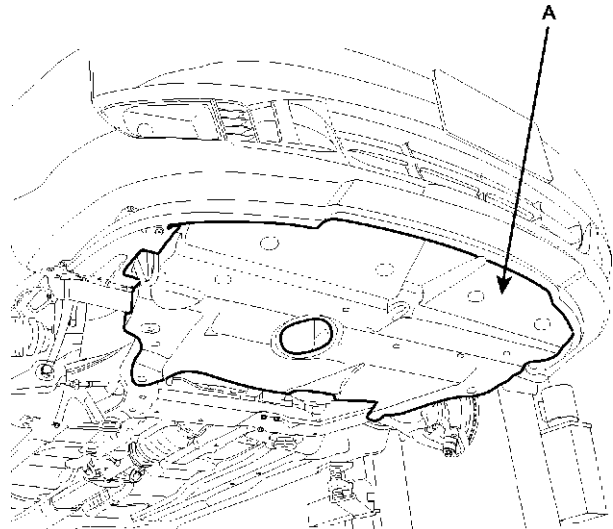

KMRE009H

7. Drain the engine coolant and remove the radiator cap to speed up draining.
8. Remove the upper radiator hose and the lower radiator hose(A).

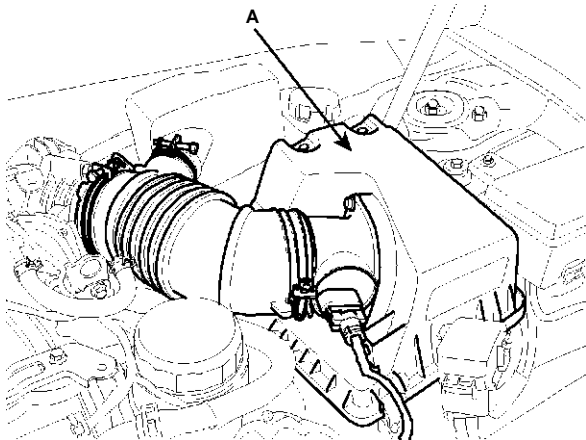

KKCF015Q

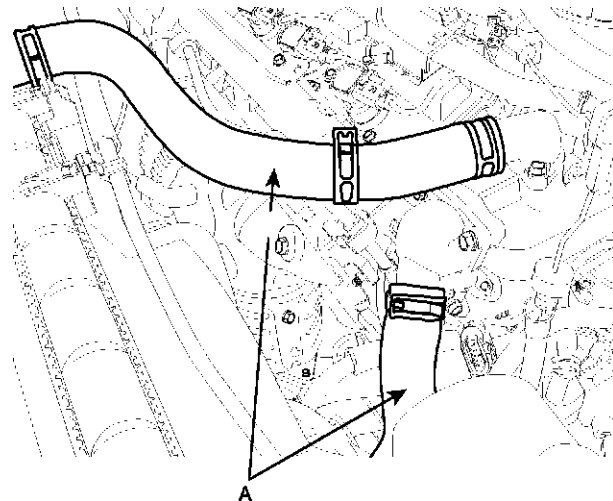

KKCF014H

9. Remove transaxle oil cooler hose(A).

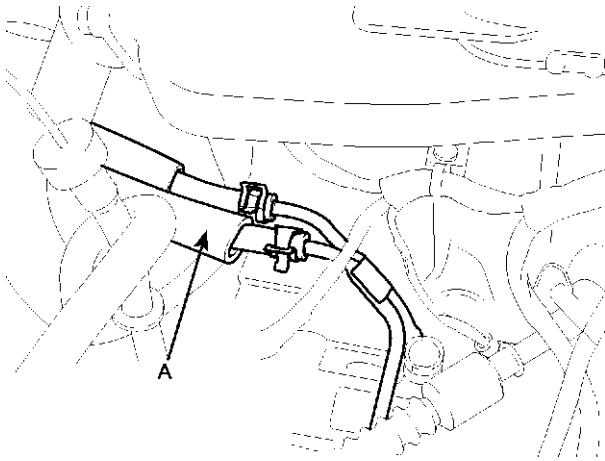

2) Disconnect LH front oxygen sensor connector(A).

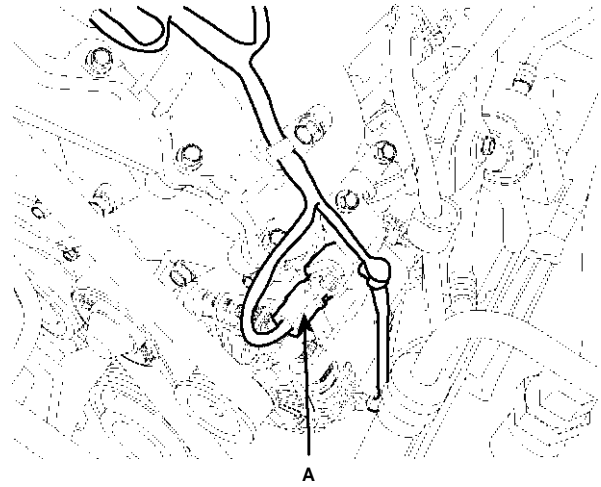

KKCF014Q

10. Remove engine wiring.

1) Disconnect RH oxygen sensor connector(A).

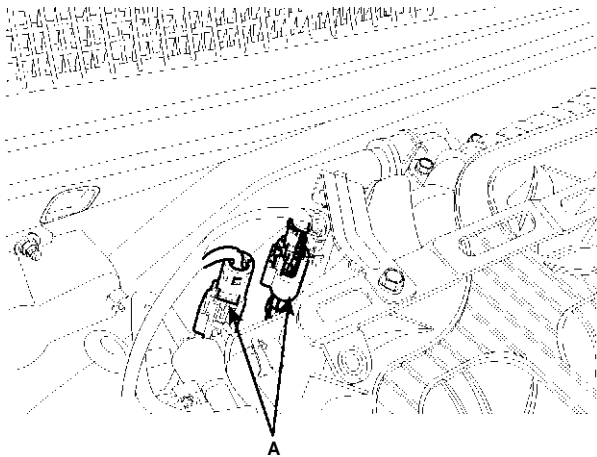

KKCF014L

3) Disconnect LH rear oxygen sensor connector(A) and CPS connector(B).

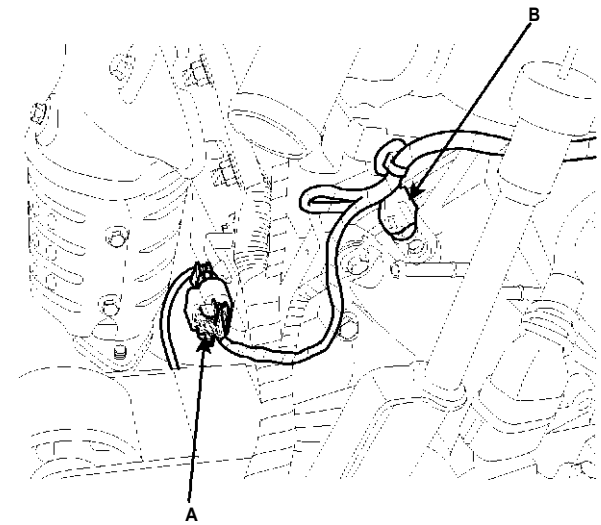

KKCF014Y

11. Disconnect the transaxle wire harness connector and remove transaxle control cable.

1) Remove the wiring brackets(A, B).

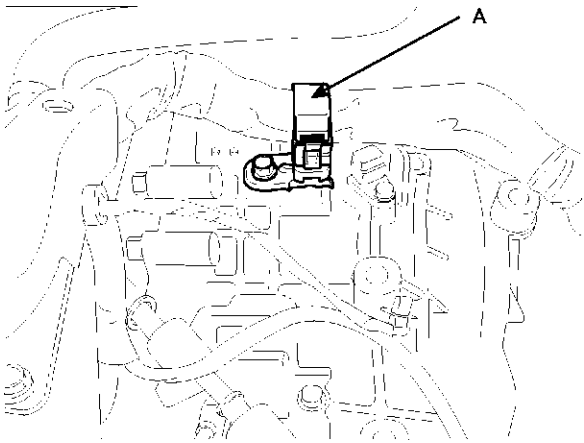

KKCF014Z

2) Remove the inhibitor switch connector(A) and shift cable(B).

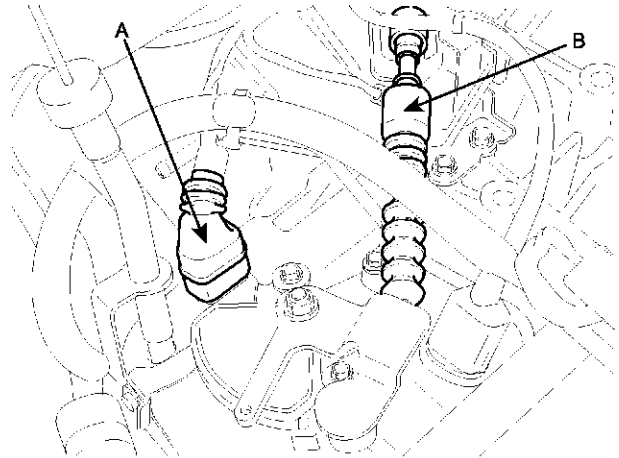

KKCF015B

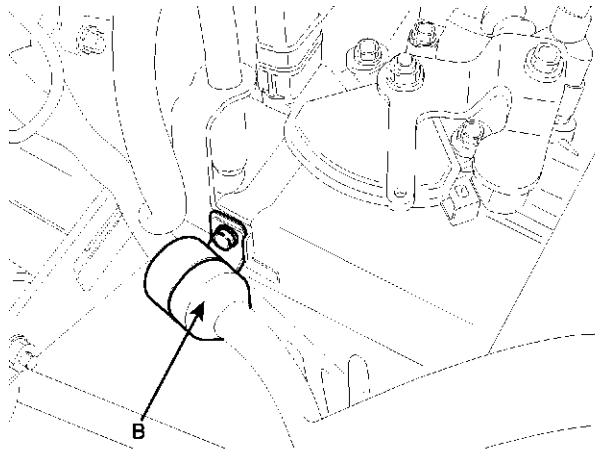

KKCF015A

3) Remove the solenoid valve connector(A).

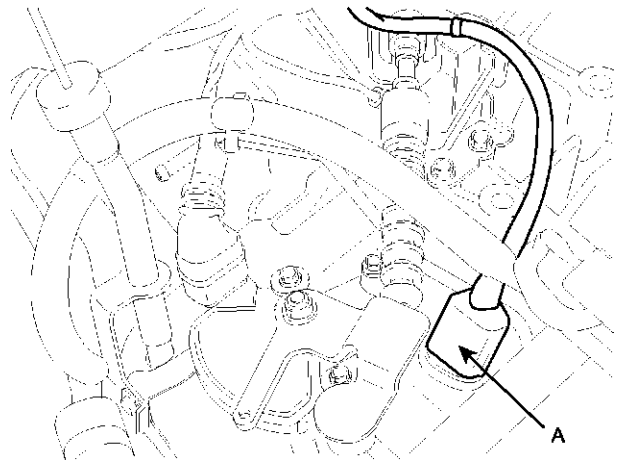

KKCF015C

- 4) Remove the input speed sensor, output speed sensor(A) and vehicle speed sensor connector^).

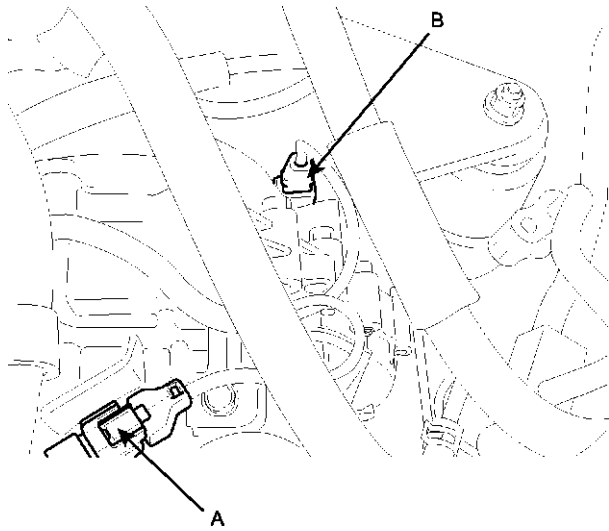

KKCF015D

19. After removing a split pin and nut from the steering bar tie rod, disconnect it. (Refer to 'ST'-group)
20. Remove front roll stopper mounting bolt.
21. Remove rear roll stopper mounting bolt.
22. Remove steering u-joint mounting (See 'ST' group)
23. Remove front exhaust pipe.
24. Supporting the cross member(A) with a jack, remove the stays(B) with the mounting bolts.

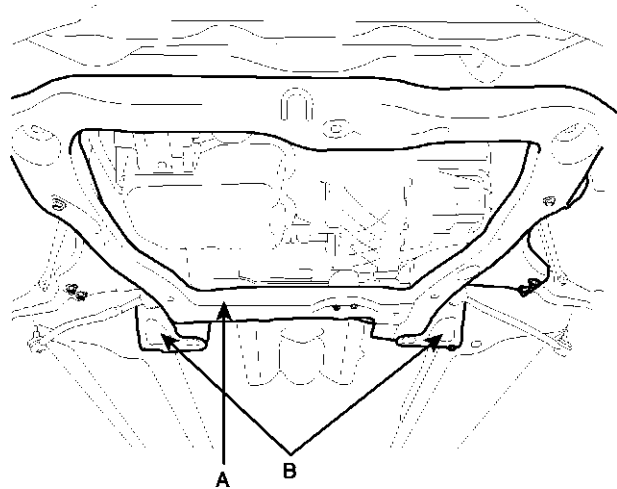

KKCF015S

12. Disconnect EPS connector.
13. Remove power steering pump hose(A).

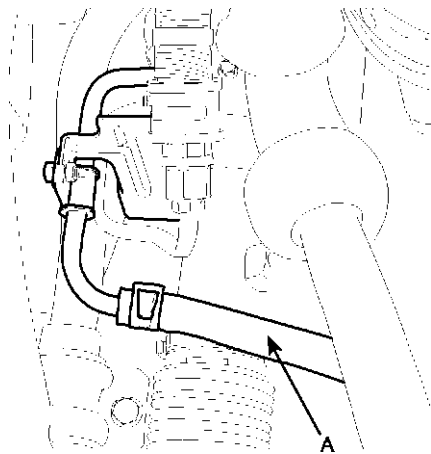

KKCF015R

14. Using the SST(09200-38001), hold the engine and transaxle assembly safely.
15. Drain transaxle oil.
16. Remove lower arm ball joint. (See 'DS' group)
17. Remove tie rod end ball joint. (See 'DS' group)
18. Remove stabilizer bar link. (See 'SS' group)

25. Remove the cross member.
26. Remove drive shaft from transaxle. (See 'DS' group)
27. Install a jack for supporting the transaxle assembly.
28. Remove the transaxle mounting bolts(A, B, C).

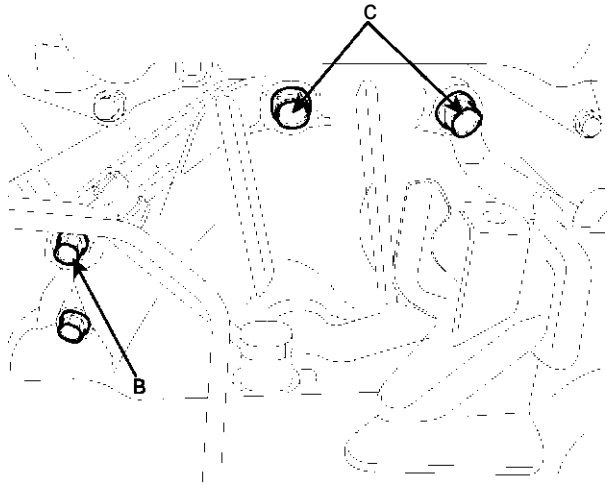

KKCF015L

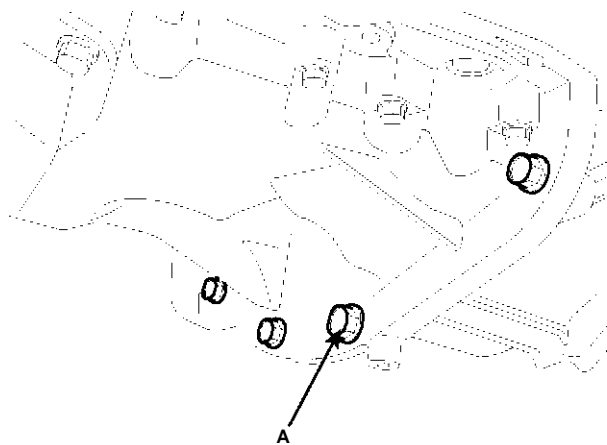

KKCF015M

29. Lower the vehicle and remove the transaxle mounting bracket.
30. Jack up the vehicle and disassemble the transaxle assembly.

INSTALLATION ECFE24EA

Installation is in the reverse order of removal.

Perform the following :

- Adjust the shift cable.
- Adjust the throttle cable.
- Refill the engine with engine oil.
- Refill the transaxle with fluid.
- Refill the radiator with engine coolant.
- Bleed air from the cooling system with the heater valve open.
- Clean the battery posts and cable terminals with sandpaper, assemble them, and apply grease to prevent corrosion.
- Inspect for fuel leakage.

After assembling the fuel line, turn on the ignition switch (do not operate the starter) so that the fuel pump runs for approximately two seconds and fuel line pressurizes.

Repeat this operation two or three times, then check for fuel leakage at any point in the fuel line.