

# Automatic Transaxle (A5HF1)

## **GENERAL**

### **AUTOMATIC TRANSAXLE SYSTEM**

AUTOMATIC TRANSAXLE  
LOW & REVERSE BRAKE  
OIL PUMP (A/T)  
PLANETARY GEAR SET

DIFFERENTIAL  
VALVE BODY  
UNDERDRIVE CLUTCH  
REVERSE AND OVERDRIVE CLUTCH  
SECOND BRAKE  
DIRECT CLUTCH  
DIRECT PLANET CARRIER ASSEMBLY

## GENERAL

### SPECIFICATION EC8A7AA4

Automatic transaxle type		A5HF1
Recommended transaxle oil		Diamond ATF SP III or SK ATF SP III
Oil quantity		10.9 Liter (Only for the reference)
Oil inspection and supplement		Every one year or every 20,000 km
Replacement	Private use (Normal use)	Every 100,000 km
	Private use (Severe use)	Every 40,000 Km in severe use(1~4)
	Business use	<ol style="list-style-type: none"> <li>1. Driving on rough road(bumpy road, gravel road, snowy road, unpaved road etc.)</li> <li>2. Driving on mountain road, ascent/descent</li> <li>3. Repetition of short distance driving</li> <li>4. More than 50% operation in heavy city traffic during hot weather above 32°C</li> <li>5. Police, Taxi. Commercial type operation</li> </ol>
Gear ratio	1st	3.789
	2nd	2.064
	3rd	1.421
	4th	1.034
	5th	0.728
	Reverse	3.808
	Final reduction gear ratio	3.333

### SERVICE STANDARD

ITEM	VALUE (mm/inch)
Input shaft end play	0.7~1.45 / 0.0276~0.0571
Low & Reverse brake pressure plate end play	1.65~2.11 / 0.0650~0.0831
Reaction plate snap end play	0~0.16 / 0~0.0063
2ND brake pressure plate end play	1.09~1.55 / 0.0429~0.0610
Underdrive sun gear end play	0.25~0.45 / 0.0098~0.0177
Differential bearing spacer end play	0.045~0.105 / 0.0018~0.0041
Underdrive clutch snap ring end play	1.6~1.8 / 0.0630~0.0709
Direct clutch reaction plate snap ring end play	0.6~0.8 / 0.0236~0.0315
Reverse clutch snap ring end play	0~0.09 / 0~0.0035
Overdrive clutch snap ring end play	1.0~1.2 / 0.0394~0.0472
Reverse clutch reaction plate snap ring end play	1.5~1.7 / 0.0591~0.0669

**TIGHTENING TORQUE**

ITEM	Nm	Kgf.cm	lb-ft
Transfer drive gear	31.4~36.3	320.0~370.0	23.1~26.8
Rear cover	19.6~25.5	200.0~260.0	14.5~18.8
Anchor plug	83.4~112.8	850.0~1150.0	61.5~83.2
Oil pump pipe	9.8~11.8	100.0~120.0	7.2~8.7
Oil pump	19.6~25.5	200.0~260.0	14.5~18.8
Torque converter housing	42.0~54.0	428.0~551.0	31.0~39.9
Valve body	9.8~11.8	100.0~120.0	7.2~8.7
VFS reservoir	9.8~11.8	100.0~120.0	7.2~8.7
Detent spring	4.9~6.9	50.0~70.0	3.6~5.1
Valve body cover	9.8~11.8	100.0~120.0	7.2~8.7
Vehicle speed sensor	3.9~5.9	40.0~60.0	2.9~4.3
Inhibiter switch	9.8~11.8	100.0~120.0	7.2~8.7
Manual control lever	17.7~24.5	180.0~250.0	13.0~18.1
Input/Output speed sensors	9.8~11.8	100.0~120.0	7.2~8.7
Reduction brake piston rod fixing nut	14.7~24.5	150.0~250.0	10.8~18.1
Sub frame bracket	88.3~107.9	900.0~1100.0	65.1~79.6
Valve body inside seperating plate	4.9~6.9	50.0~70.0	3.6~5.1
Valve body cover seperating plate	9.8~11.8	100.0~120.0	7.2~8.7
Direct planetary carrier lock nut	156.9~176.5	1600.0~1800.0	115.7~130.2

**SEALANTS**

Rear cover liquid gasket	Specified sealant
Rear cover liquid gasket	Threebond 1281B or LOCTITE FMD-546
Torque converter housing liquid gasket	
Valve body liquid gasket	

**SNAP RINGS, SPACERS, THRUST WASHERS &  
RACES AND PRESSURE PLATES FOR ADJUSTING**

Part name	Part No.	Thickness[mm(inch)]	Identification
Thrust washer (for input shaft end play)	45544-39180	1.8 (0.0709)	
	45544-39200	2.0 (0.0787)	
	45544-39220	2.2 (0.0866)	
	45544-39240	2.4 (0.0945)	
	45544-39260	2.6 (0.1024)	
	45544-39280	2.8 (0.1102)	
Spacer (for differential bearing end play)	45849-39883	0.83 (0.0327)	83
	45849-39886	0.86 (0.0339)	86
	45849-39889	0.89 (0.0350)	89
	45849-39892	0.92 (0.0362)	92
	45849-39895	0.95 (0.0374)	95
	45849-39898	0.98 (0.0386)	98
	45849-39801	1.01 (0.0398)	01
	45849-39804	1.04 (0.0409)	04
	45849-39807	1.07 (0.0421)	07
	45849-39810	1.10 (0.0433)	10
	45849-39813	1.13 (0.0455)	13
	45849-39816	1.16 (0.0457)	16
	45849-39819	1.19 (0.0469)	19
	45849-39822	1.22 (0.0480)	22
	45849-39825	1.25 (0.0492)	25
	45849-39828	1.28 (0.0504)	28
	45849-39831	1.31 (0.0516)	31
45849-39834	1.34 (0.0528)	34	
45849-39837	1.37 (0.0539)	37	

Part name	Part No.	Thickness[mm(inch)]	Identification
Snap ring (for underdrive clutch snap ring end play)	45427-39520	2.0 (0.0787)	
	45427-39521	2.1 (0.0827)	
	45427-39522	2.2 (0.0866)	
	45427-39523	2.3 (0.0906)	
	45427-39524	2.4 (0.0945)	
	45427-39525	2.5 (0.0984)	
	45427-39526	2.6 (0.1024)	
	45427-39527	2.7 (0.1063)	
	45427-39528	2.8 (0.1102)	
	45427-39529	2.9 (0.1142)	
	45427-39530	3.0 (0.1182)	
	45427-39519	1.9 (0.0748)	
	45427-39516	1.6 (0.0630)	
	45427-39517	1.7 (0.0669)	
45427-39518	1.8 (0.0709)		
Snap ring (for direct clutch snap ring end play)	45556-39520	2.0 (0.0787)	
	45556-39521	2.1 (0.0827)	
	45556-39522	2.2 (0.0866)	
	45556-39523	2.3 (0.0906)	
	45556-39524	2.4 (0.0945)	
	45556-39525	2.5 (0.0984)	
	45556-39526	2.6 (0.1024)	
	45556-39527	2.7 (0.1063)	
	45556-39528	2.8 (0.1102)	
	45556-39529	2.9 (0.1142)	
	45556-39530	3.0 (0.1182)	
Snap ring (for reverse clutch snap ring end play)	45443-39148		
	45853-39153		
	45459-39158		
	45853-39163		

Part name	Part No.	Thickness[mm(inch)]	Identification
Snap ring (for overdrive clutch snap ring end play)	45427-39520	2.0 (0.0787)	
	45427-39521	2.1 (0.0827)	
	45427-39522	2.2 (0.0866)	
	45427-39523	2.3 (0.0906)	
	45427-39524	2.4 (0.0945)	
	45427-39525	2.5 (0.0984)	
	45427-39526	2.6 (0.1024)	
	45427-39527	2.7 (0.1063)	
	45427-39528	2.8 (0.1102)	
	45427-39529	2.9 (0.1142)	
	45427-39530	3.0 (0.1182)	
	45427-39519	1.9 (0.0748)	
	45427-39516	1.6 (0.0630)	
	45427-39517	1.7 (0.0669)	
	45427-39518	1.8 (0.0709)	
Snap ring (for reverse clutch reaction plate snap ring end play)	45432-39518	1.8 (0.0709)	
	45432-39517	1.7 (0.0669)	
	45432-39516	1.6 (0.0630)	
	45432-39519	1.9 (0.0748)	
	45432-39528	2.8 (0.1102)	
	45432-39527	2.7 (0.1063)	
	45432-39526	2.6 (0.1024)	
	45432-39525	2.5 (0.0984)	
	45432-39524	2.4 (0.0945)	
	45432-39523	2.3 (0.0906)	
	45432-39522	2.2 (0.0866)	
	45432-39521	2.1 (0.0827)	
45432-39520	2.0 (0.0787)		

**SPECIAL TOOLS** E97C0A27

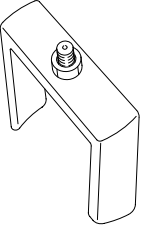
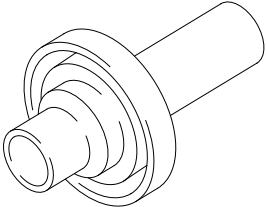
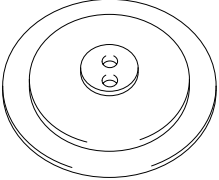
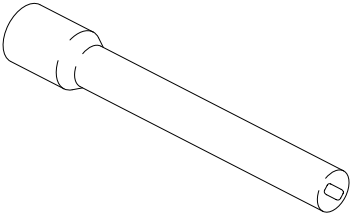
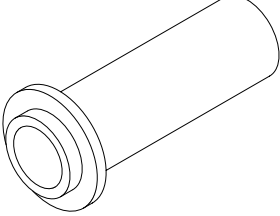
Tool (Number and name)	Illustration	Use
09453-3A110 Spring compressor	 <p style="text-align: right;">KKCF100A</p>	<ul style="list-style-type: none"> <li>- Removal and installation of one way clutch inner race snap ring</li> </ul>
09431-39000 Oil seal installer	 <p style="text-align: right;">KKCF100B</p>	<ul style="list-style-type: none"> <li>- Installation of differential bearing output race</li> </ul>
09456-39100 Clearance dummy plate	 <p style="text-align: right;">KKCF100C</p>	<ul style="list-style-type: none"> <li>- Installation of brake pressure plate</li> </ul>
09454-3A110 Reduction socket	 <p style="text-align: right;">KKCF100D</p>	<ul style="list-style-type: none"> <li>- Adjustment of reduction brake piston rod</li> </ul>
09452-21200 Oil pump oil seal installer	 <p style="text-align: right;">KKCF100E</p>	<ul style="list-style-type: none"> <li>- Installation of oil seal in a oil pump</li> </ul>

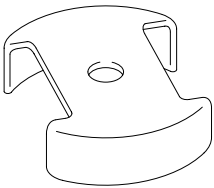
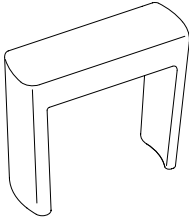
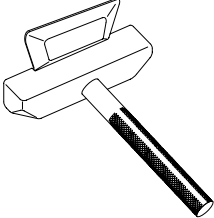
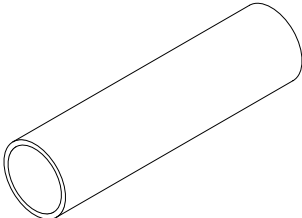
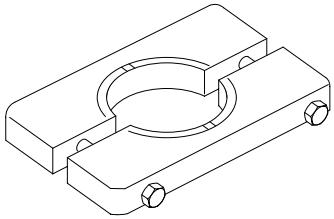
Tool (Number and name)	Illustration	Use
09453-24000 Snap ring compressor	 <p style="text-align: right;">KKCF100F</p>	<ul style="list-style-type: none"> <li>- Removal and installation of under drive clutch snap ring</li> </ul>
09453-4C400 Spring compressor	 <p style="text-align: right;">KKCF100G</p>	<ul style="list-style-type: none"> <li>- Removal and installation of direct clutch snap ring</li> <li>- Removal and installation of reverse &amp; over drive clutch spring retainer snap ring</li> </ul>
09215-3C000 Oil fan remover	 <p style="text-align: right;">KKCF100H</p>	<ul style="list-style-type: none"> <li>- Removal of valve body cover</li> </ul>
09455-21100 Bearing installer	 <p style="text-align: right;">KKCF100I</p>	<ul style="list-style-type: none"> <li>- Installation of the ball bearing and the transfer drive gear</li> </ul>
09457-22000 Removing plate	 <p style="text-align: right;">KKCF100J</p>	<ul style="list-style-type: none"> <li>- Removal of the differential bearing, the transfer shaft bearing and drive gear bearing.</li> </ul>

# AUTOMATIC TRANSAXLE SYSTEM

## AUTOMATIC TRANSAXLE

### COMPONENTS(1) E22DC9E6

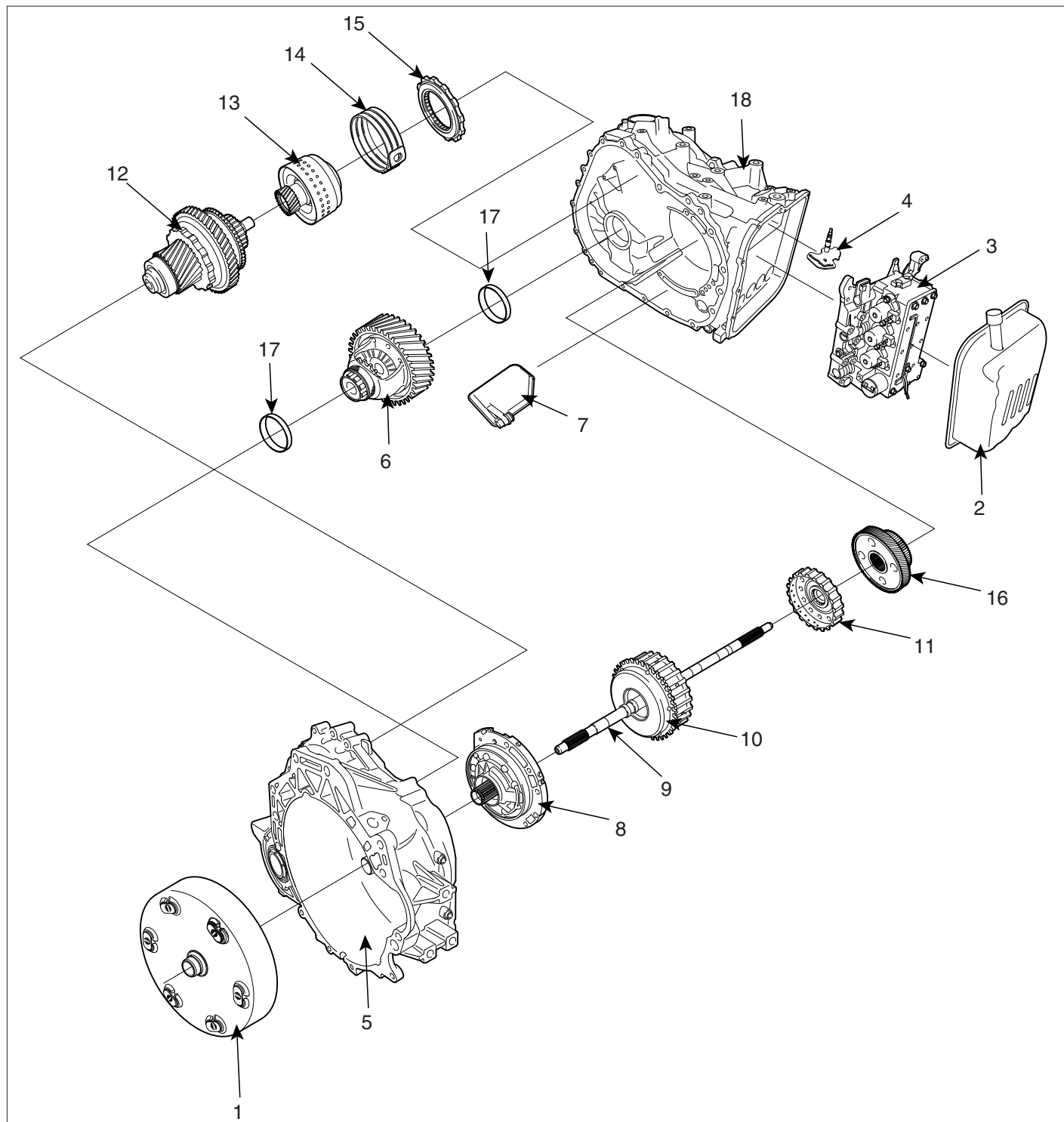

- |                                  |                                       |                               |
|----------------------------------|---------------------------------------|-------------------------------|
| 1. Torque converter              | 7. Main oil filter                    | 13. Direct clutch assembly    |
| 2. Valve body cover              | 8. Oil pump                           | 14. Reduction brake bend      |
| 3. Valve body assembly           | 9. Input shaft                        | 15. One way clutch            |
| 4. Manual control shaft assembly | 10. Underdrive clutch assembly        | 16. Transfer drive gear       |
| 5. Converter housing             | 11. Underdrive clutch hub             | 17. Differential bearing race |
| 6. Differential assembly         | 12. Direct planetary carrier assembly | 18. Transaxle case            |

**COMPONENTS(2)**

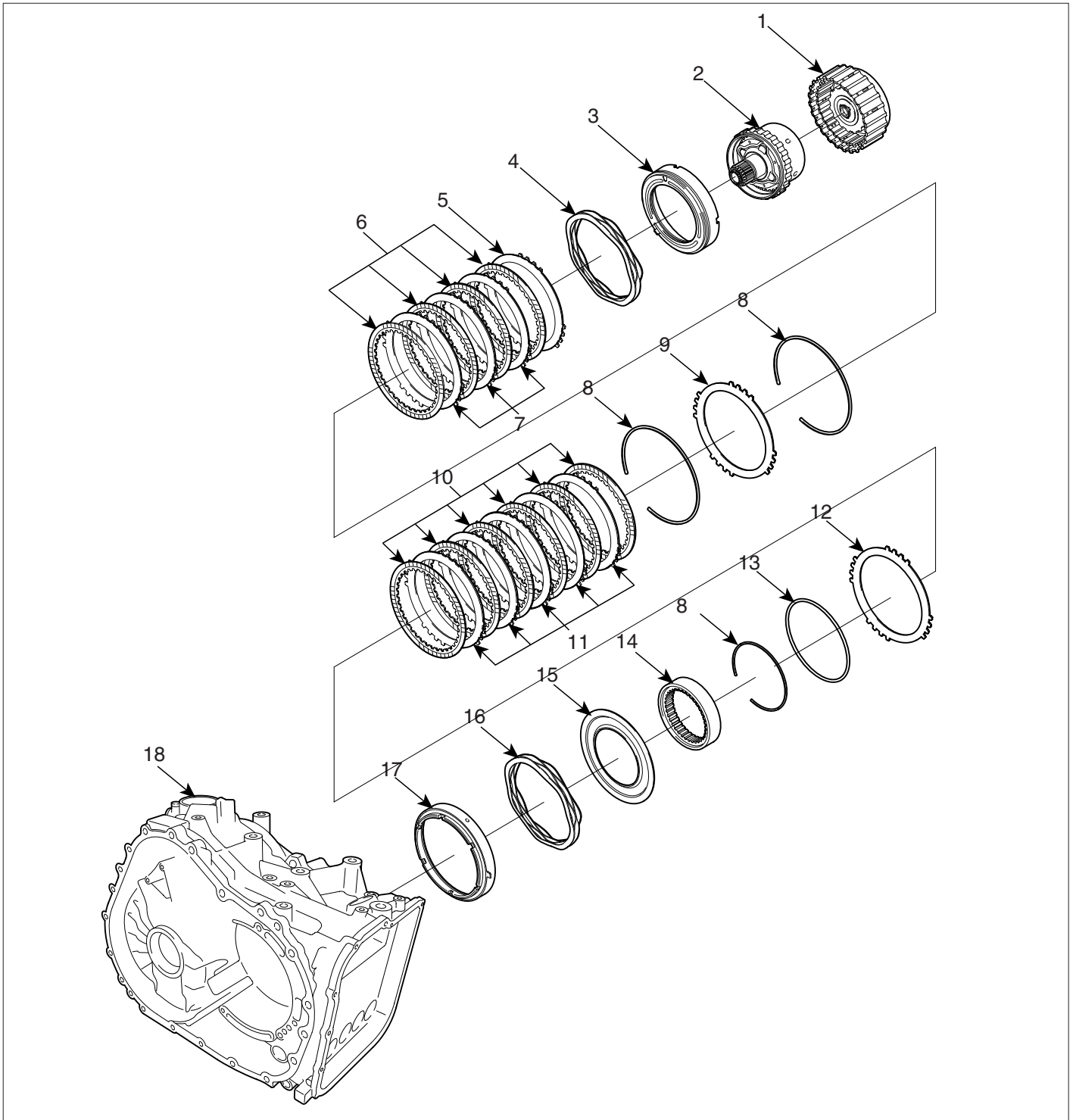

- |                             |                                      |                                     |
|-----------------------------|--------------------------------------|-------------------------------------|
| 1. Reverse sun gear         | 7. 2nd brake plates                  | 13. Wave spring                     |
| 2. Planetary gear assembly  | 8. Snap ring                         | 14. Oneway clutch inner race        |
| 3. 2nd brake retainer       | 9. Brake reaction plate              | 15. Brake spring retainer           |
| 4. 2nd brake return spring  | 10. Brake discs                      | 16. Low&Reverse brake return spring |
| 5. 2nd brake pressure plate | 11. Brake plates                     | 17. Low&Reverse brake piston        |
| 6. 2nd brake discs          | 12. Low&Reverse brake pressure plate | 18. Transaxle case                  |

EKRF500B

### DISASSEMBLY E93BEAC8

#### CAUTION

- **Automatic transaxles consist of delicate parts. Be careful not to damage them in disassembly and assembly.**
- **Spread a rubber mat on a workbench and keep it clean.**
- **Do not use cotton or muslin fiber. Use nylon fabric or paper towel.**
- **Cleanse the disassembled components. Clean metal parts with a general cleaning agent or dry them with a blower.**
- **Clean clutch discs, thrust plates made of resin, and rubber parts with automatic transaxle fluid and keep them dust free.**
- **If transaxle body has been damaged, disassemble and clean cooler system.**

1. Remove the torque converter.
2. Measure the input shaft(A) end play using a dial gauge.

---

Input shaft end play:  
0.7~1.45mm(0.0276~0.0571 inch)

---

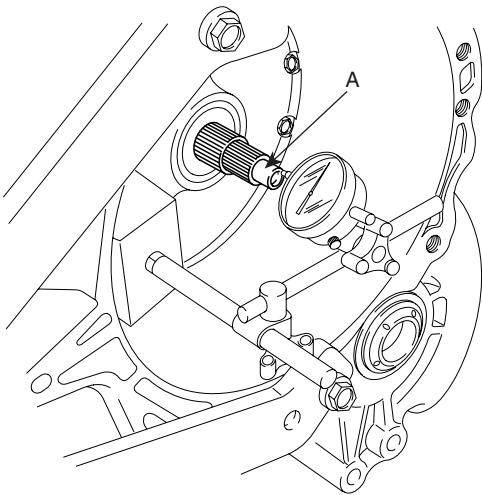

KKCF002A

3. Remove the fluid level gauge.

4. Remove the input(A) and the output speed sensor(B).

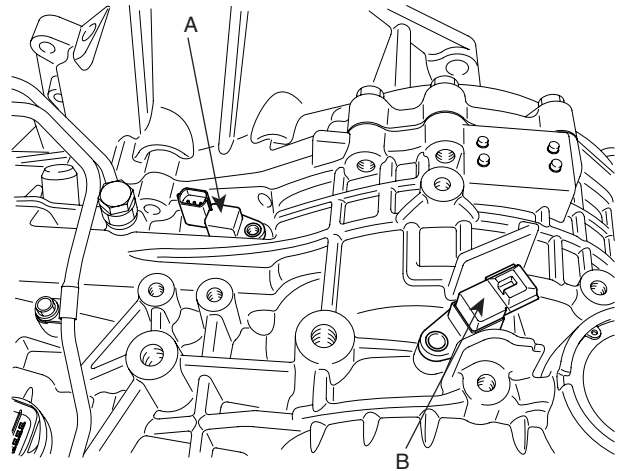

KKCF002B

5. Remove the eyebolt, the gasket, and the fluid cooler feed tube.
6. Remove the manual control lever(B) and the transaxle range switch(A).

#### CAUTION

**Remove the transaxle range switch(A) with the valve body installed.**

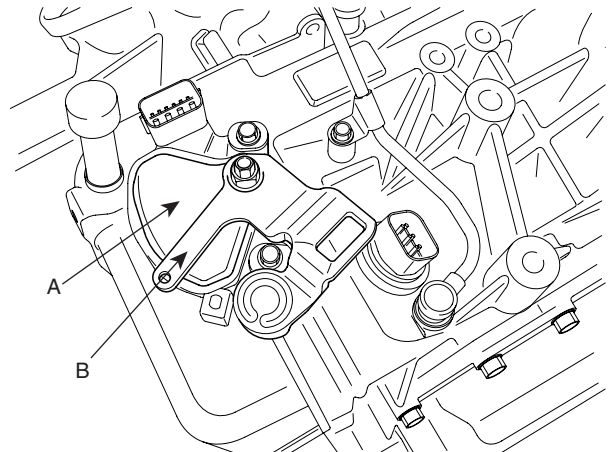

KKCF002C

**AT -12**

**AUTOMATIC TRANSAXLE (A5HF1)**

7. Remove the speedometer gear(or vehicle speed sensor(A)).

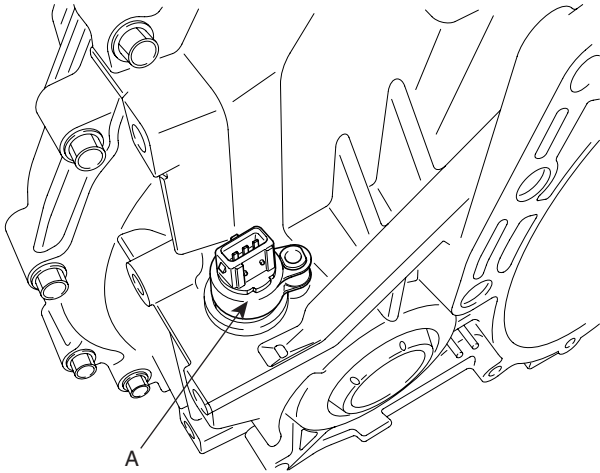

KKCF002D

9. Remove the manual control shaft detent spring(A).

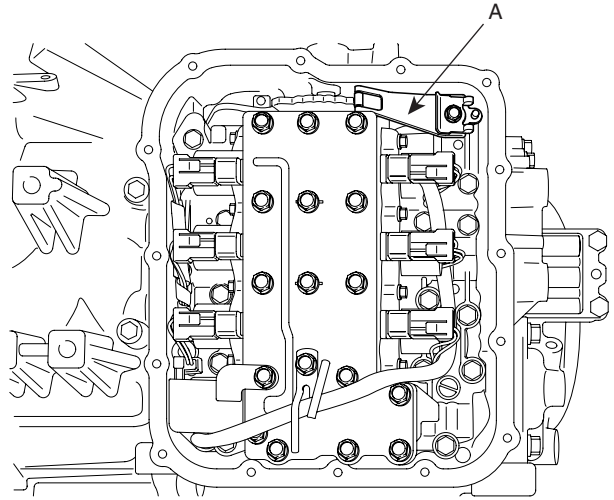

KKCF002F

8. Using the SST(09215-3C000), remove the valve body cover(A).

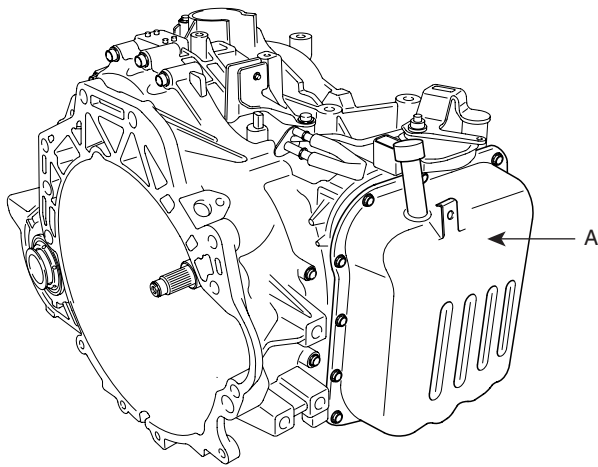

KKCF002E

10. Remove the VFS(variable force solenoid) reservoir(A) and tube assembly(B).

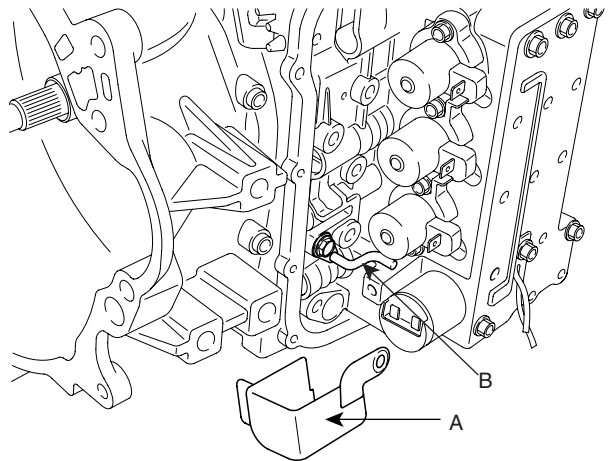

KKCF002H

**AUTOMATIC TRANSAXLE SYSTEM**

11. Disconnect the harness connector from the valve body.
12. Remove the valve body mounting bolts(26EA), except those bolts(A) marked on illustration.  
(6X45-1EA, 6X75-1EA, 6X106-10EA, 6X38-9EA, 6X20-2EA, 6X25-2EA, 6X30-1EA)

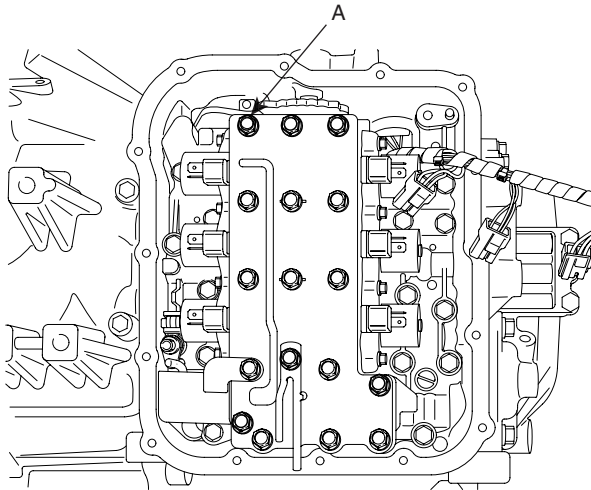

KKCF002G

13. Remove the valve body(A) and the steel balls(2EA).

**! CAUTION**

**Be careful not to lose the steel balls.**

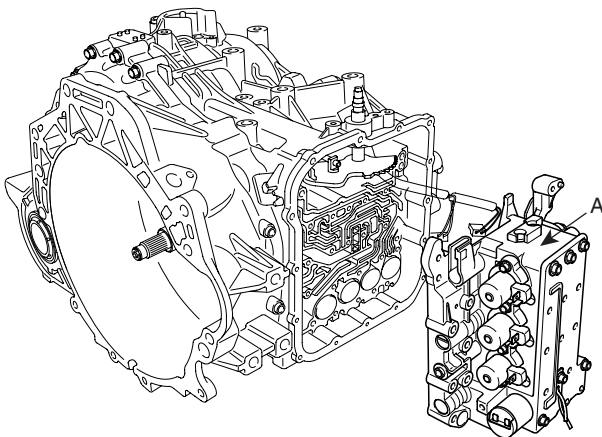

KKCF002I

14. Remove the solenoid valve harness snap ring(A).

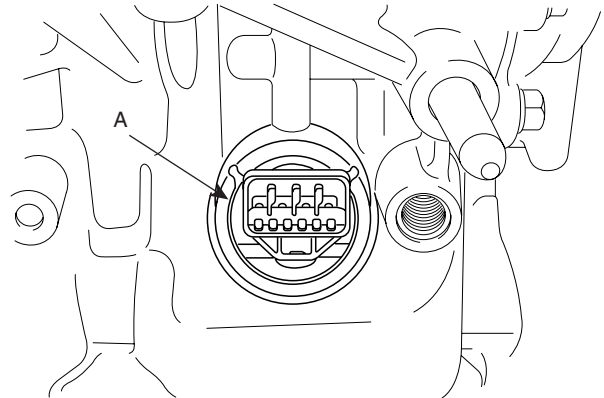

KKCF002J

15. Remove the solenoid valve harness.

16. Remove the strainer(A).

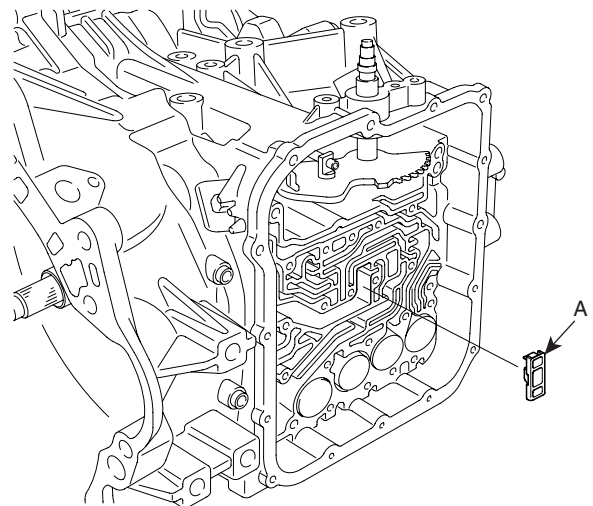

KKCF002K

## AT -14

## AUTOMATIC TRANSAXLE (A5HF1)

17. Remove the 2ND brake retainer oil seal(A).

**⚠ CAUTION**

*If the 2ND brake retainer oil seal is not removed, it may be damaged when removing and installing the second brake piston.*

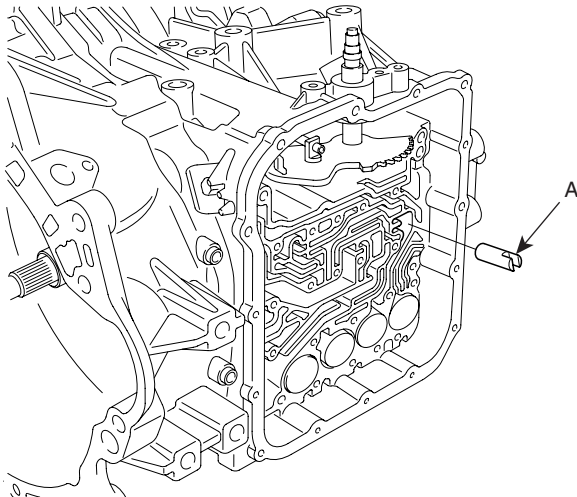

KKCF002L

18. Remove each accumulator piston and spring.

No.	Name
1	Low & Reverse brake
2	Under drive clutch
3	Second brake
4	Over drive clutch

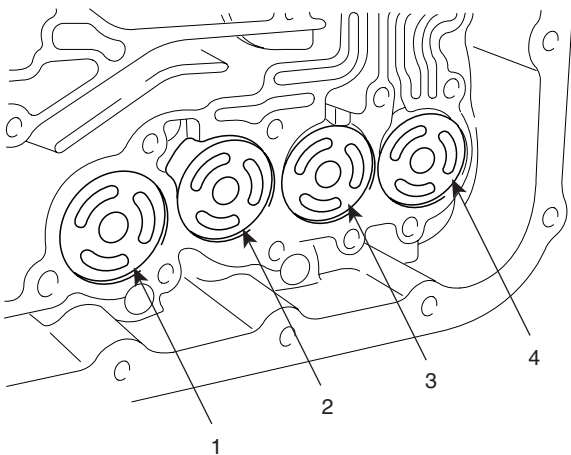

KKCF002M

19. Remove the snap ring(A), the piston(B) and reduction brake accumulator(D) and the spring(C).

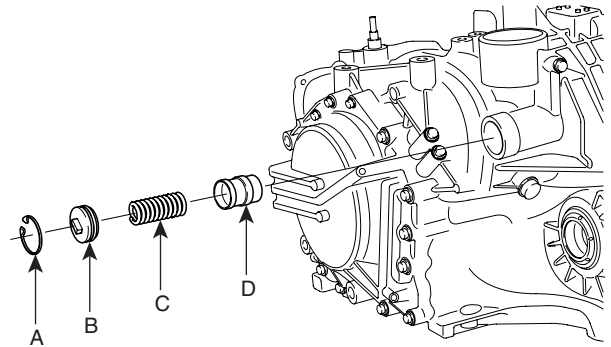

KKCF002N

20. Remove the snap ring(A) and the reduction brake piston(B).

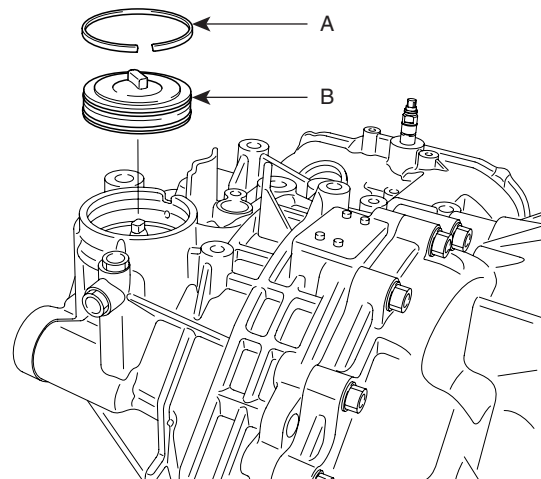

KKCF002O

**AUTOMATIC TRANSAXLE SYSTEM**

21. Remove the snap ring(A) inside first. Afterwards, remove the nut(D), the reduction brake piston(B) and the spring(C).

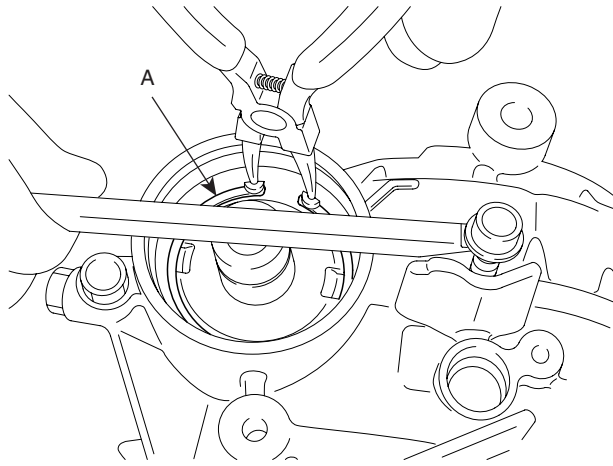

KKCF002P

22. After pulling out the roller pin(A), remove the manual control shaft assembly(B) and the parking roller rod assembly(C).

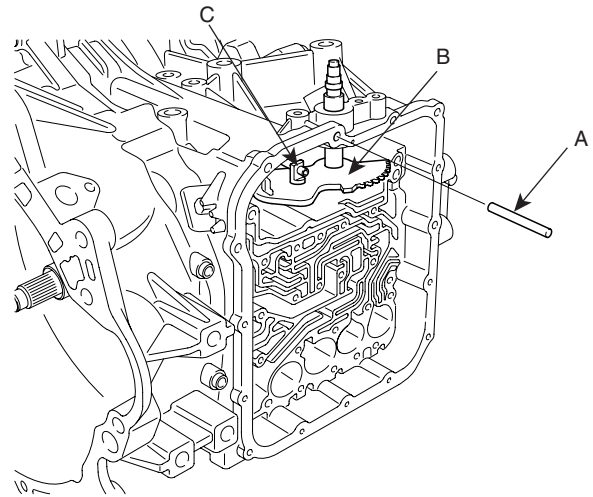

KKCF002R

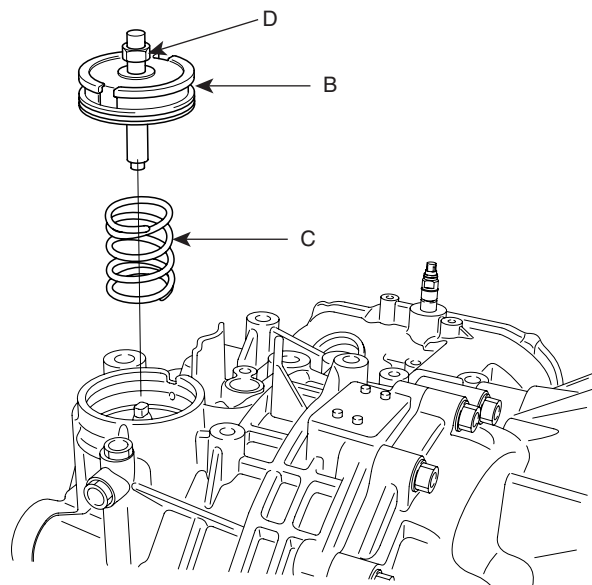

KKCF002Q

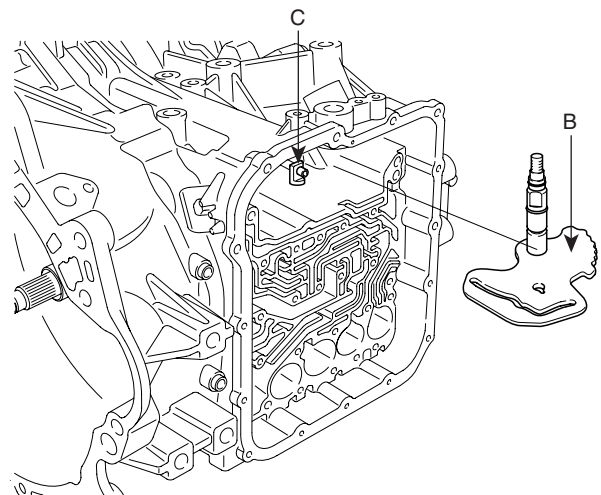

KKCF002S

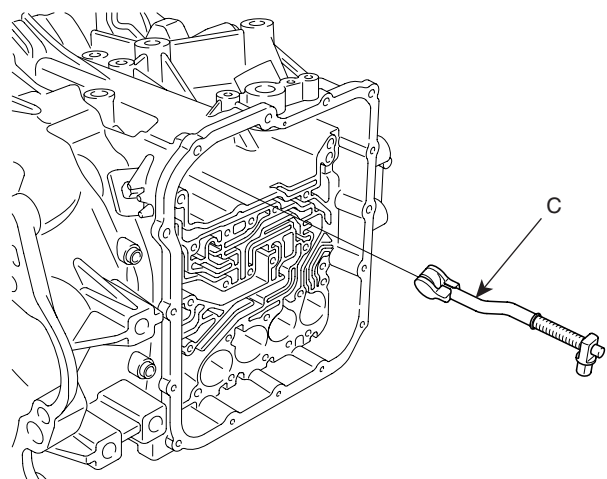

KKCF002T

**AT -16**

**AUTOMATIC TRANSAXLE (A5HF1)**

23. Loosen the torque converter housing mounting bolts(20EA) and remove the torque converter housing.

24. Remove the two O-rings(A)(2EA).

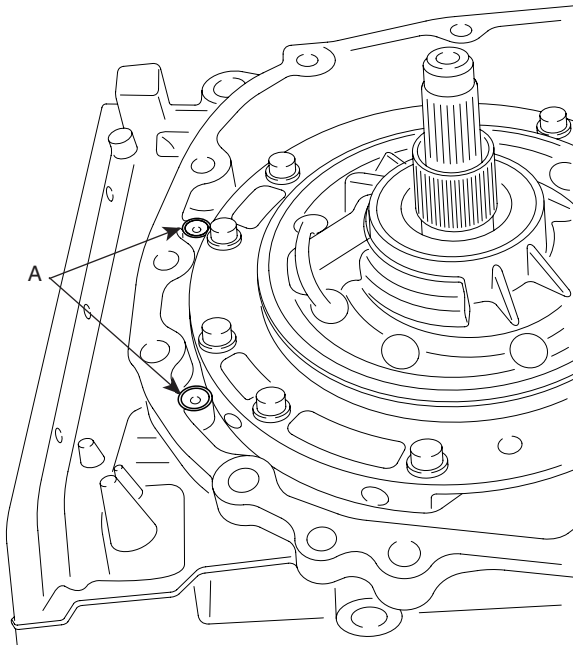

KKCF002U

25. Remove the differential assembly(A).

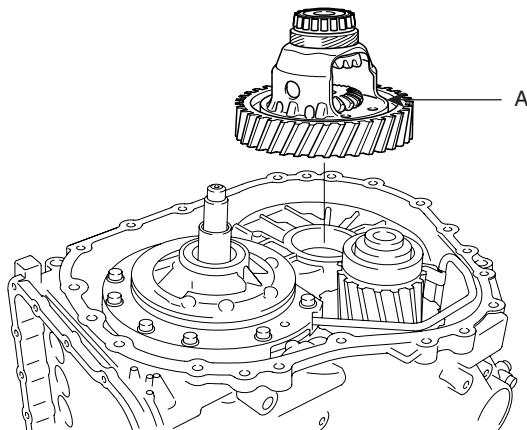

KKCF002V

26. Remove the main oil filter(B).

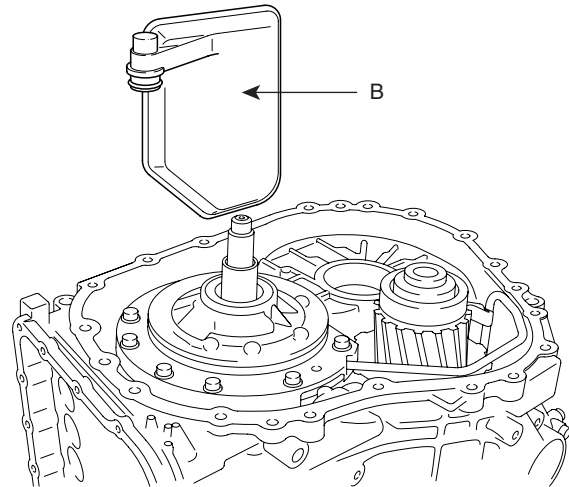

KKCF002W

27. Release the oil pump mounting bolts(A)(6EA) and the oil pump pipe mounting bolts(B)(2EA).

**! CAUTION**

**Do not disassemble the oil pump. Misalignment during assembly may damage the pump and the transaxle.**

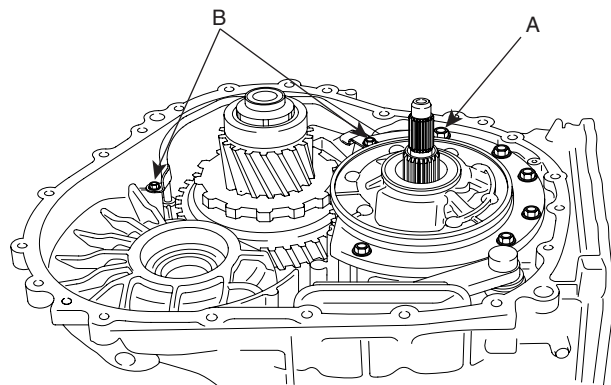

KKCF002X

28. Remove the oil pump and the oil pump gasket.

29. Separate the oil pump pipe from the oil pump.

30. Remove the thrust washer(A).

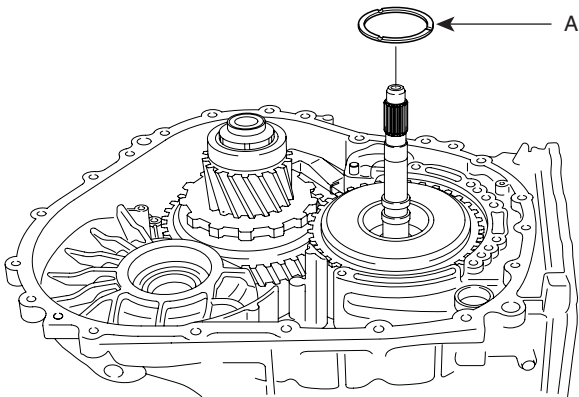

KKCF002Y

32. Remove the thrust bearing(A).

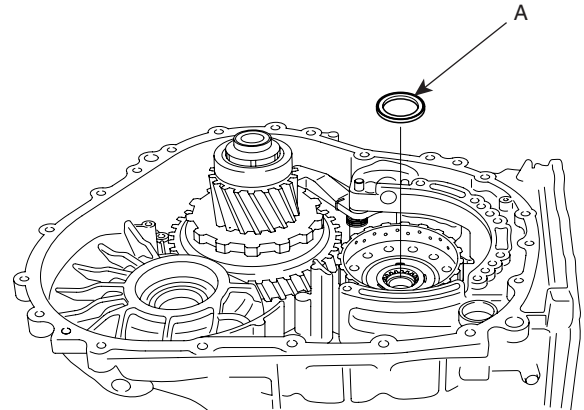

KKCF003A

31. Hold the input shaft with a hand and remove the underdrive clutch(B).

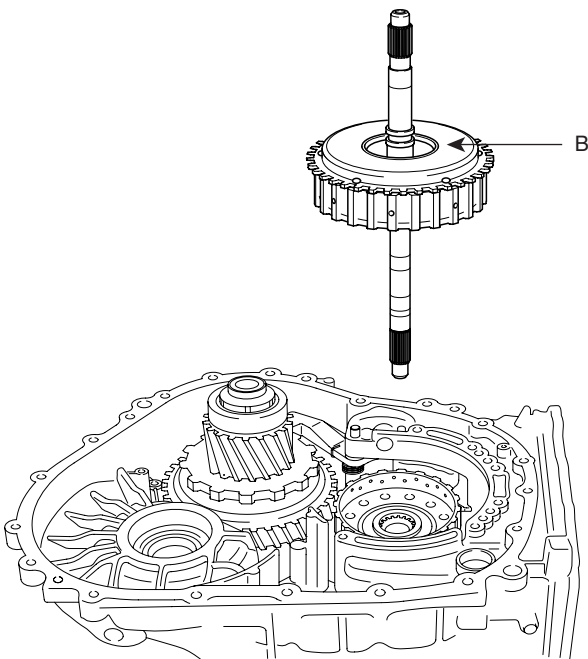

KKCF002Z

33. Remove the underdrive clutch hub(A).

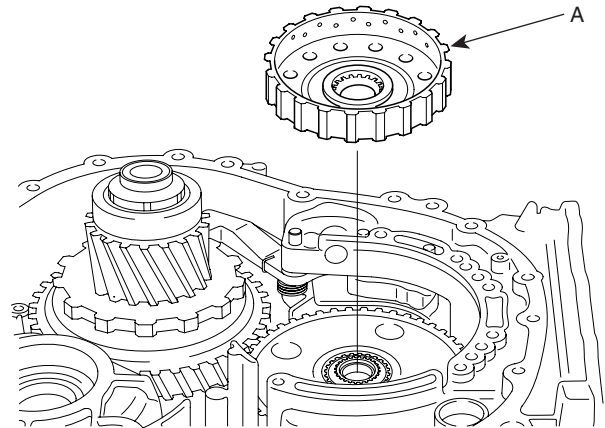

KKCF003B

34. Remove the parking roller supporting shafts(B)(2EA).

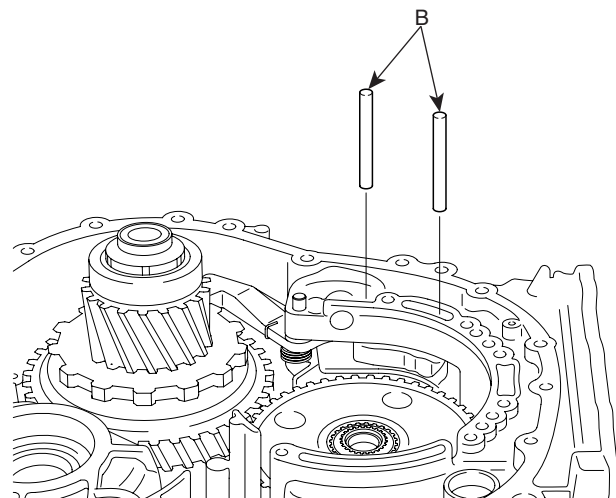

KKCF003C

35. Remove the parking roller support(A).

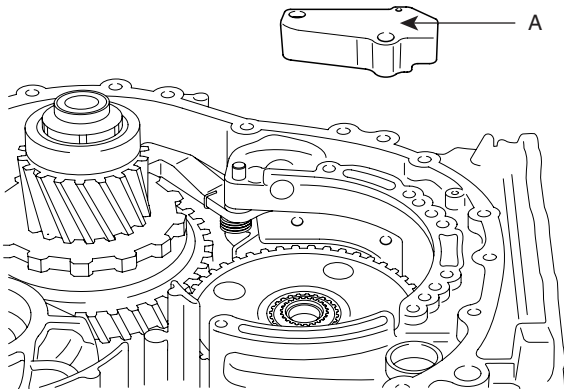

KKCF003D

38. Remove the parking sprag(A).

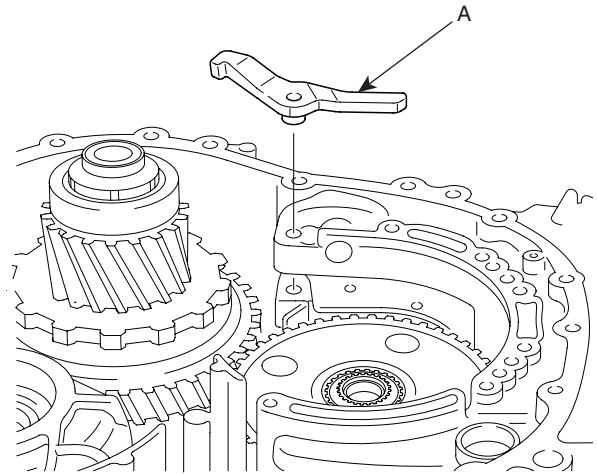

KKCF003G

36. Remove the parking sprag shaft(A).

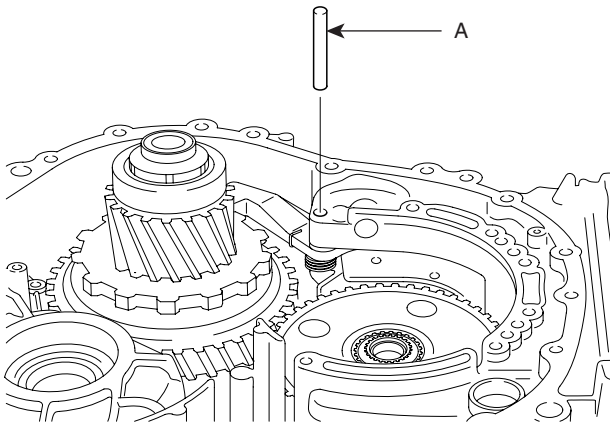

KKCF003E

39. Remove the direct planetary carrier assembly(A).

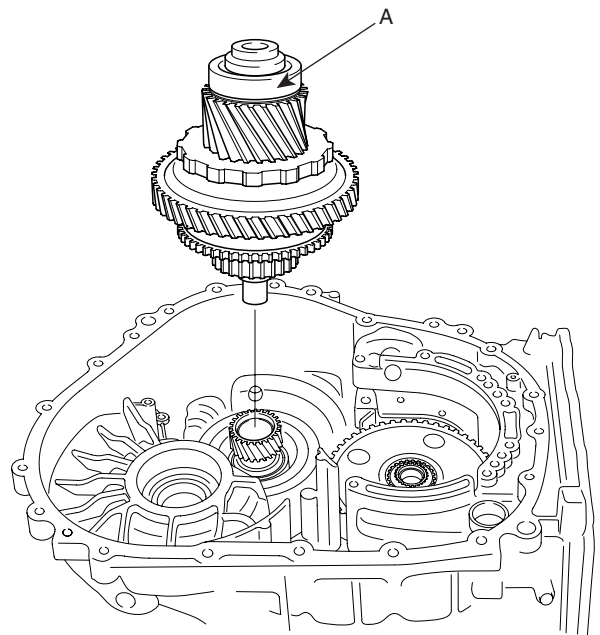

KKCF003H

37. Remove the parking sprag spring(B).

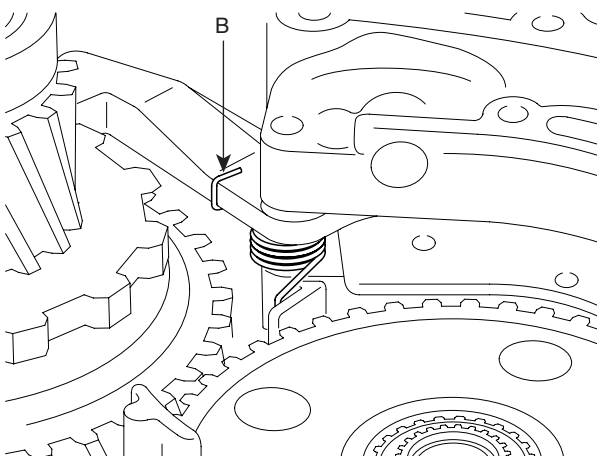

KKCF003F

40. Remove the direct clutch assembly(A).

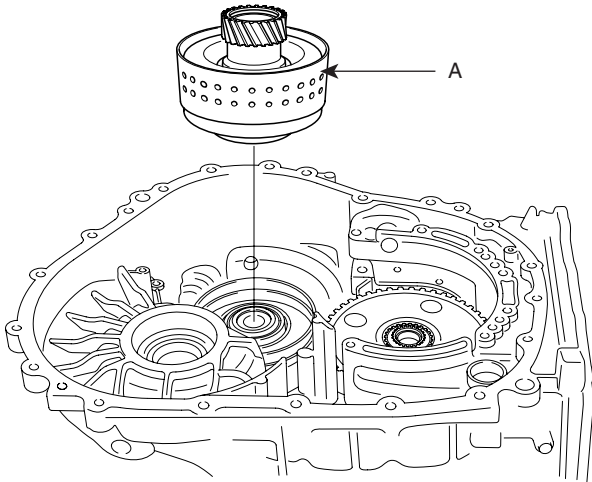

KKCF003I

42. Remove the anchor plug(A) and a O-ring.

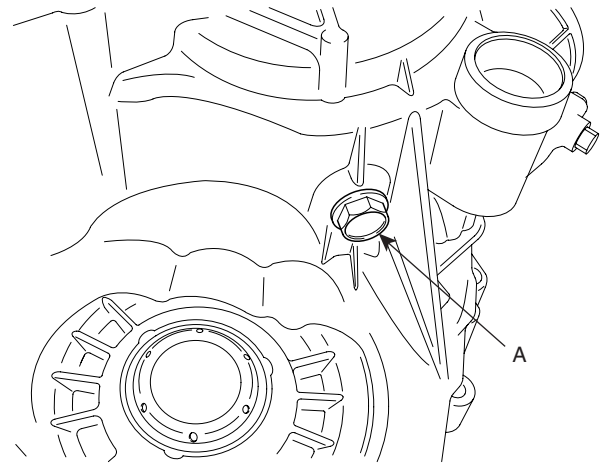

KKCF003K

41. Remove the reduction brake band(A).

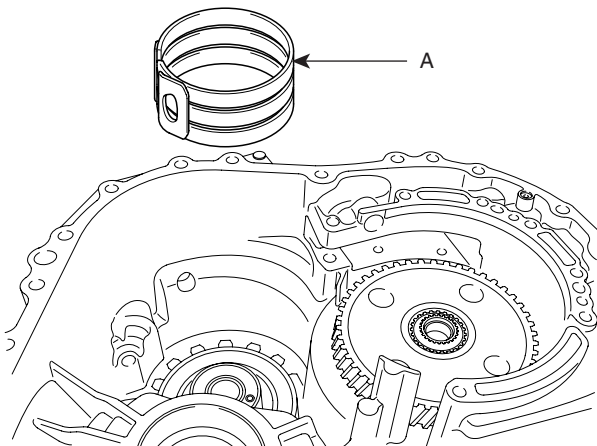

KKCF003J

43. Remove the thrust bearing(A) and race.

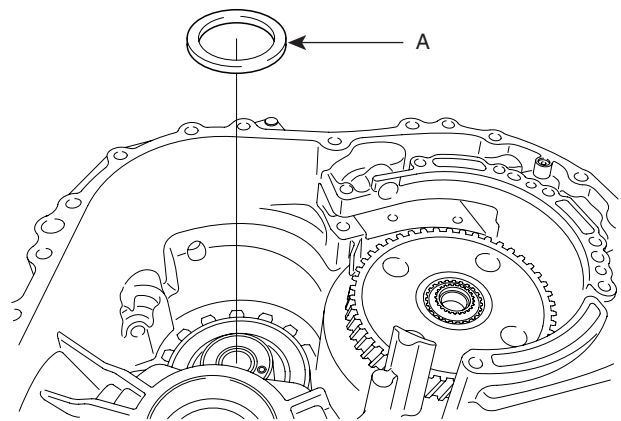

KKCF003L

44. Remove the rear cover(A).

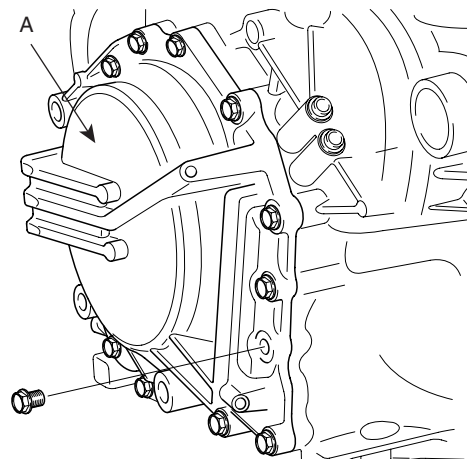

KKCF003M

45. Remove the thrust race(A) and the seal rings(B)(4EA).

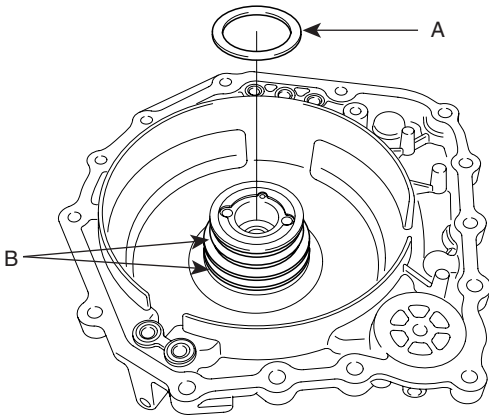

KKCF003N

47. Remove the reduction accumulator piston assembly(A) and the coil spring(B).

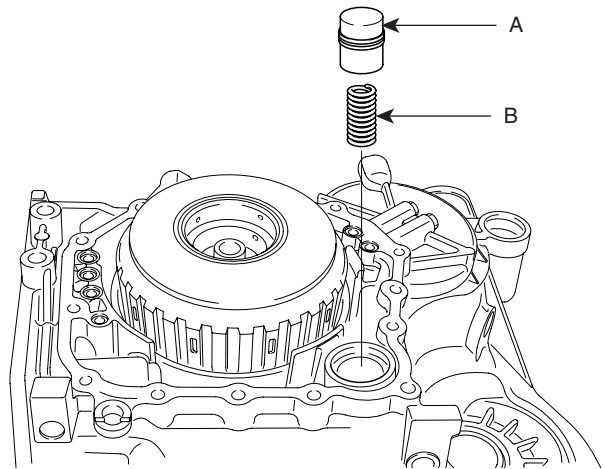

KKCF003P

46. Remove the thrust bearing(A) and the O-rings(B)(6EA).

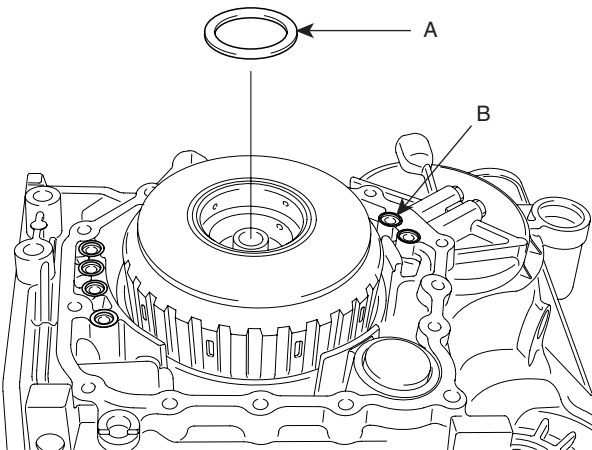

KKCF003O

48. Remove the reverse and overdrive clutch(A).

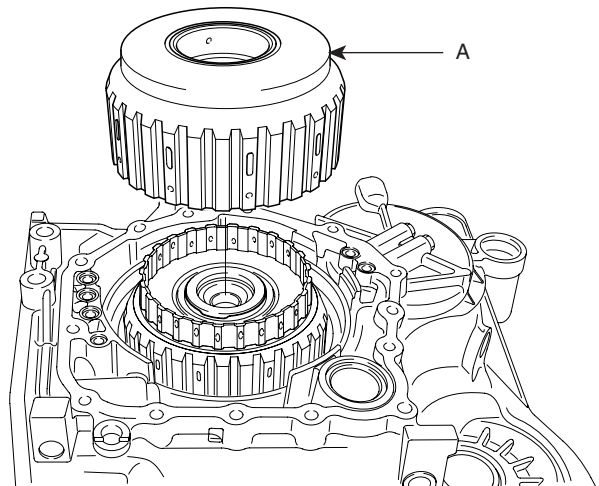

KKCF003Q

49. Remove the thrust bearing(A).

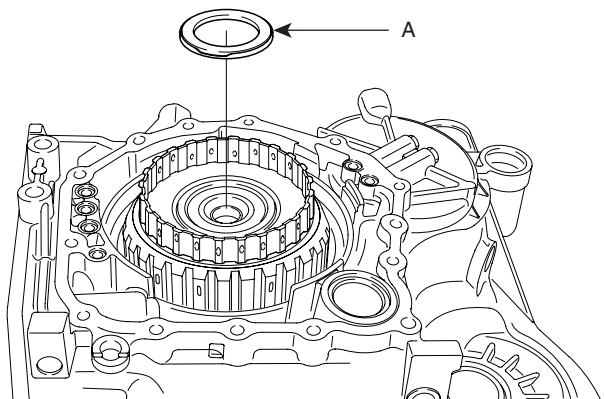

KKCF003R

**AUTOMATIC TRANSAXLE SYSTEM**

50. Remove the overdrive clutch hub(A) and the thrust bearing(B).

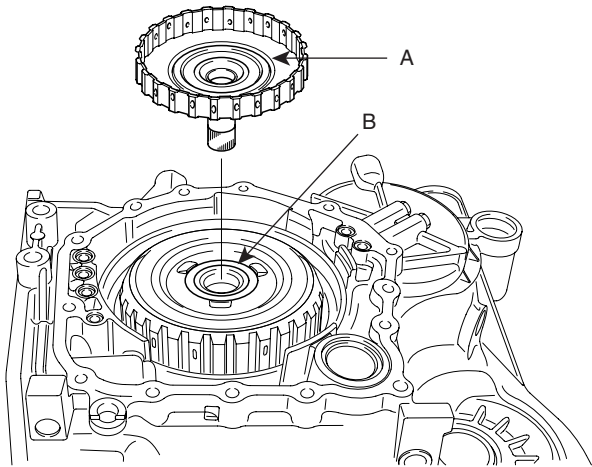

KKCF003S

53. Remove the second brake snap ring and retainer(A).

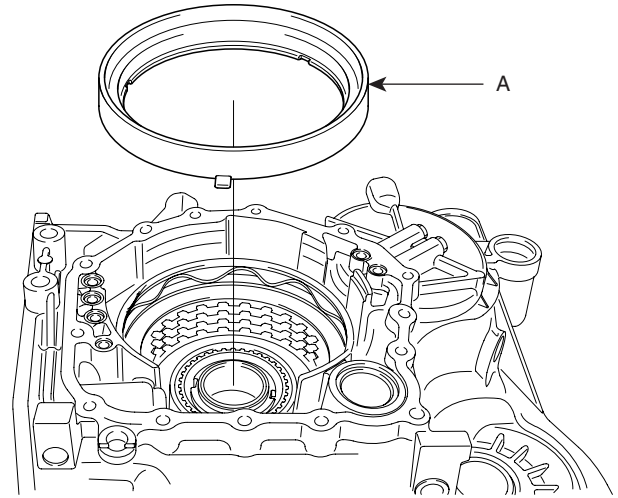

KKCF003V

51. Remove the reverse sun gear(A).

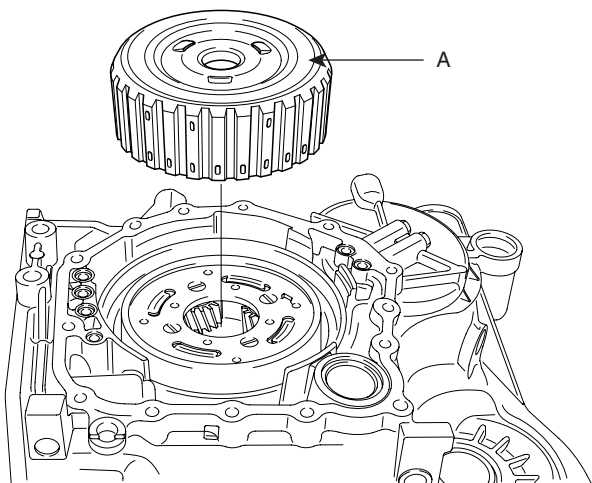

KKCF003T

54. Remove the second brake return spring(A).

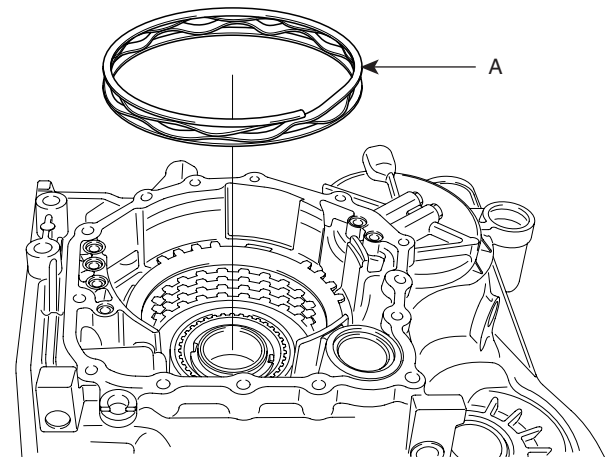

KKCF003W

52. Remove the planetary gear assembly(A).

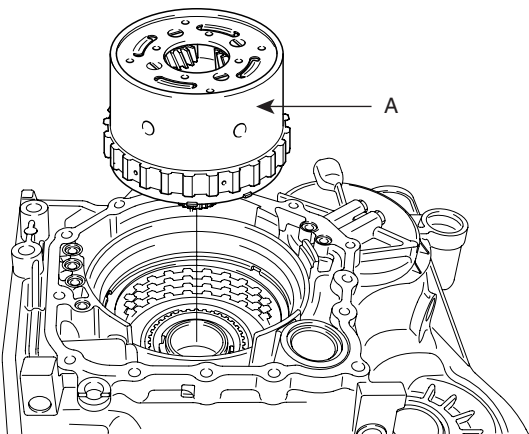

KKCF003U

55. Remove the second brake pressure plate(A), brake discs(B)(4EA) and plates(C)(3EA).

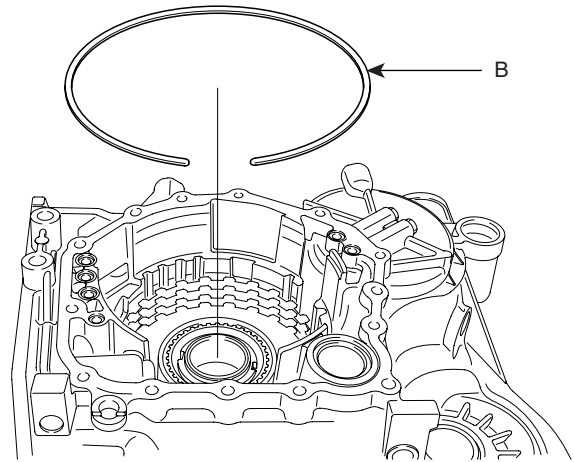
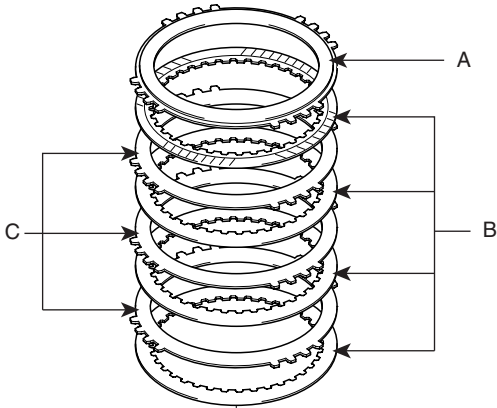

KKCF003Z

58. Remove the brake discs(A)(6EA) and plates(B)(5EA).

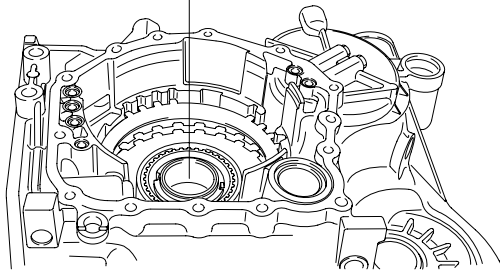

KKCF003X

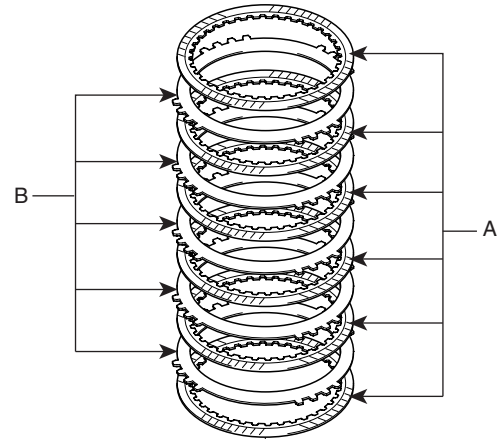

56. Remove a snap ring.

57. Remove the brake reaction plate(A) and snap ring(B).

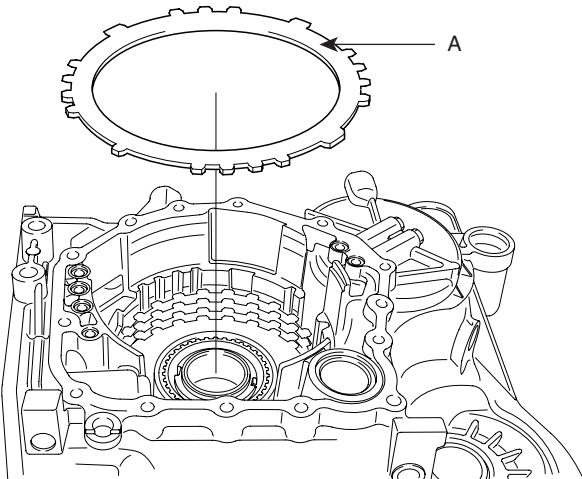

KKCF003Y

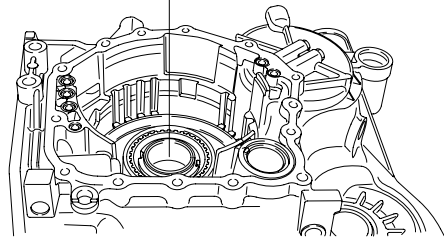

KKCF004A

**AUTOMATIC TRANSAXLE SYSTEM**

59. Remove the LR brake pressure plate(A).

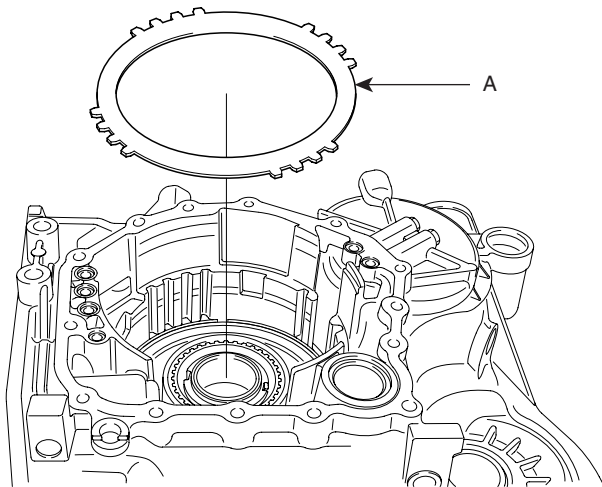

KKCF004B

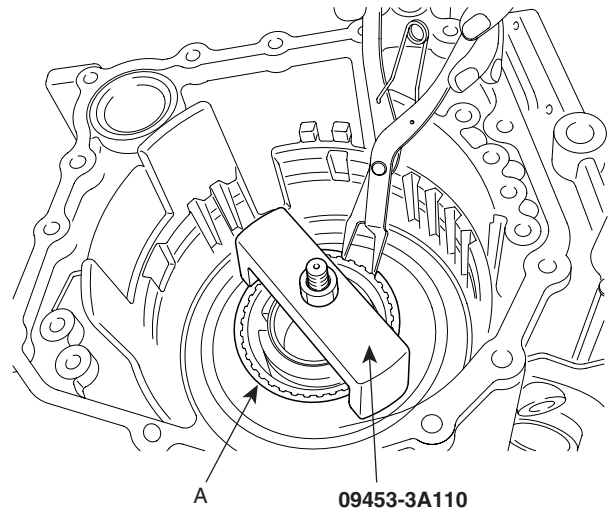

KKCF004D

60. Remove the wave spring(A).

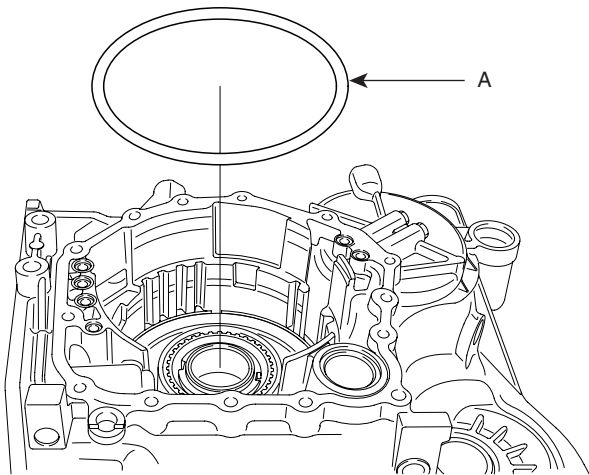

KKCF004C

62. Remove the one way clutch inner race(A) and brake spring retainer(B).

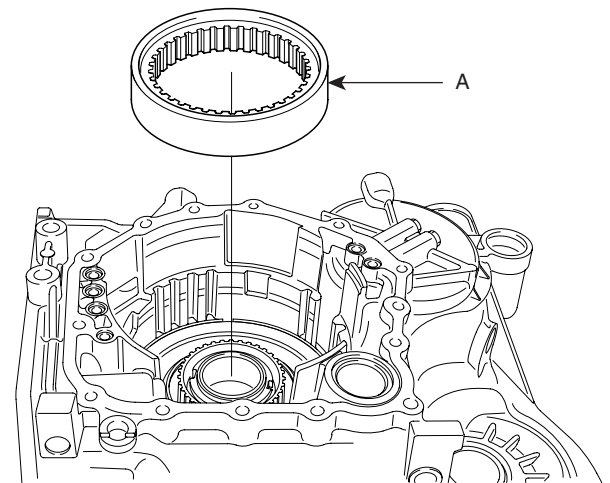

KKCF004E

61. Remove the snap ring(A) using SST(09453-3A110).

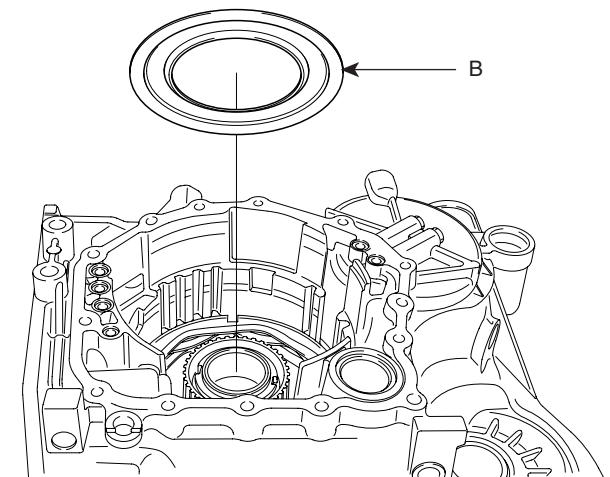

KKCF004F

63. Remove the LR brake return spring(A) and piston(B).

64. After removing the snap ring(A) fixing the one way clutch, take off the one way clutch(B).

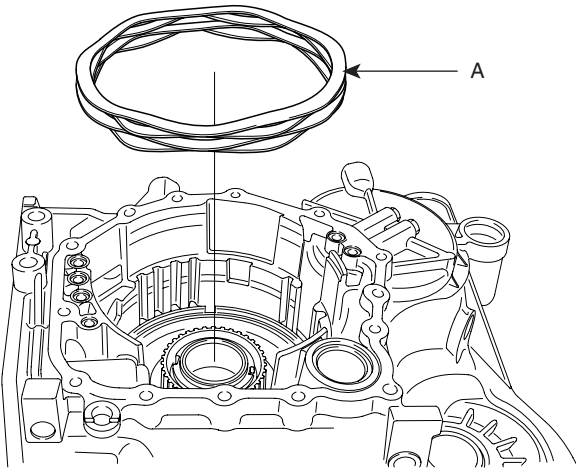

KKCF004G

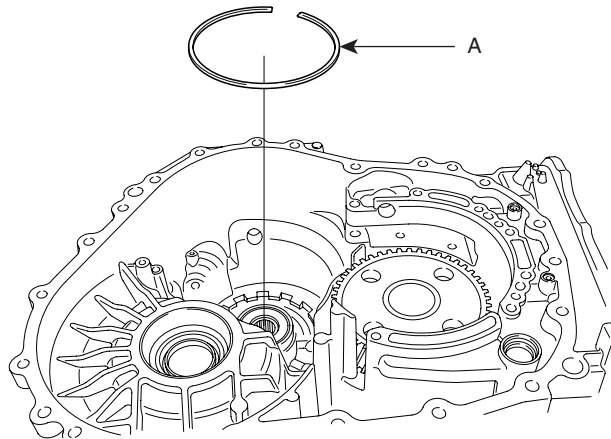

KKCF004I

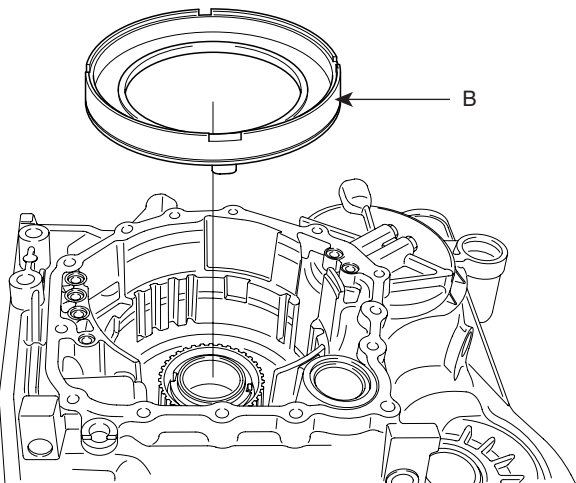

KKCF004H

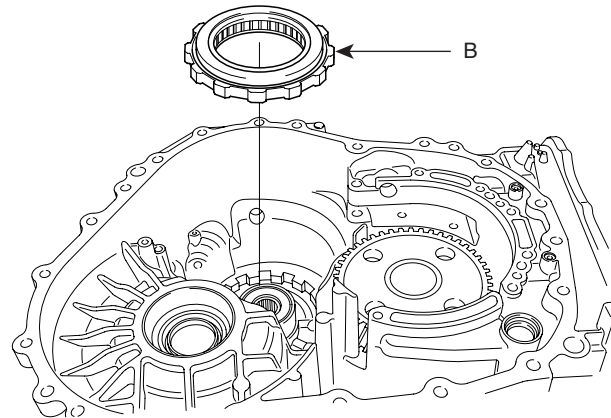

KKCF004J

**AUTOMATIC TRANSAXLE SYSTEM**

65. Remove the seal rings(B)(2EA) and needle roller bearing(A).

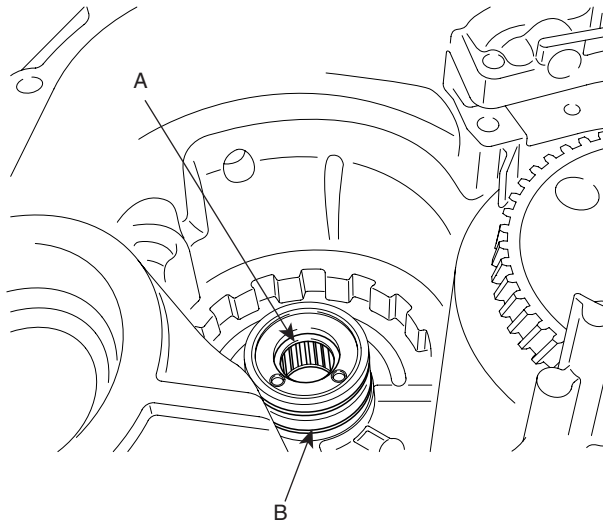

KKCF004K

**NOTE**

*Do not replace the rear bearing if there's no faulty after checking because the transaxle case may be damaged in replacing the rear bearing.*

66. Release the transfer drive gear(A) mounting bolts(8EA).

**NOTE**

*After releasing the four bolts, first, find the others by revolving the gear.*

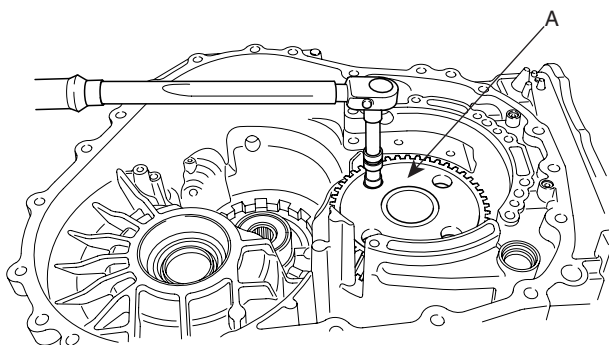

KKCF004L

67. Remove the transfer drive gear(A).

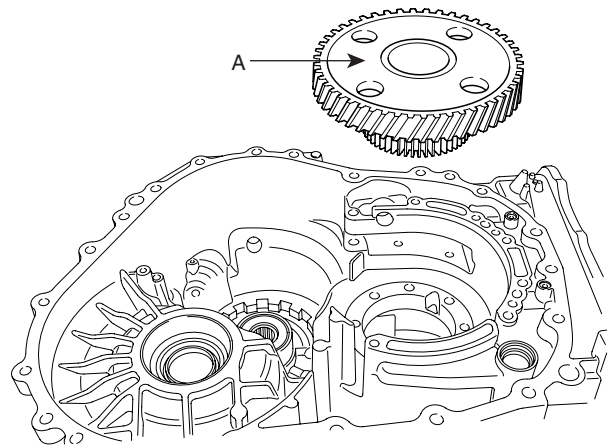

KKCF004M

68. Remove the differential bearing outer race(B) out of the transaxle case(A).

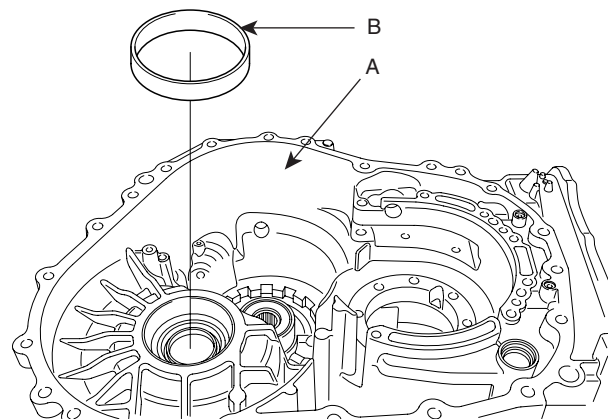

KKCF004N

69. Remove the differential bearing outer race(B) and spacer out of the converter housing(A).

**REASSEMBLY** ED50E858

**CAUTION**

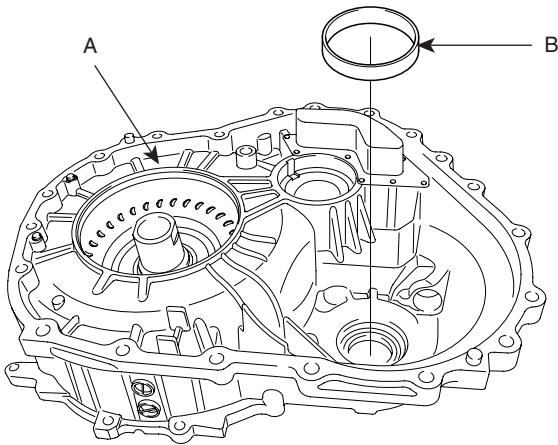

KKCF004O

70. Remove the differential oil seal(A).

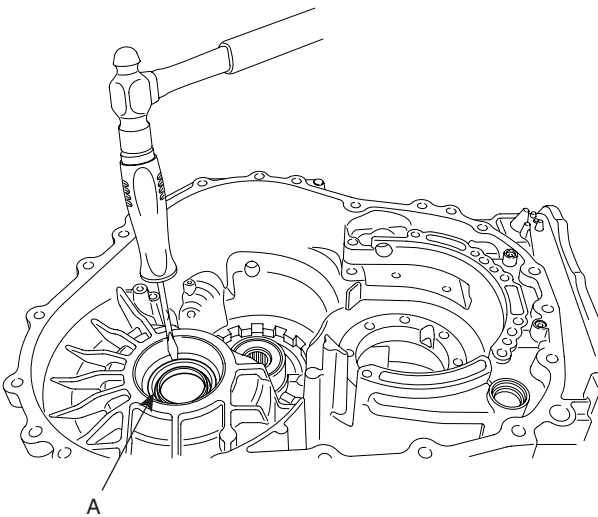

KKCF004P

- **Keep the workbench and parts always clean and dirt free.**
- **Do not use cotton gloves. Use paper towel and nylon rag. Do not use nappy fabric.**
- **Do not use grease at any place otherwise specified. Use white vaseline or blue mineral oil if necessary.**
- **Insert each snap ring firmly into the seat. Do not use deformed rings.**
- **Do not allow dirt to remain on the surface to apply liquid gasket during reassembly.**
- **Oil pump gasket, valve body mounting bolts(6X25) and oil seals shall not be used again, and use the new ones in assembly.**
- **New clutch and brake discs shall be dipped in ATF for 2 hours or more before use.**
- **In reassembly, replace ATF and cleanse its filter thoroughly. Replace the damaged filter element with a new one.**
- **Apply required minimum quantity of white vaseline, blue mineral oil, or ATF on each of the bearing part, the thrust facemoving part, the oil pump moving part, the seal ring, and the O-ring.**
- **Do not replace the ATF in the fluid cooler.**
- **Be careful not to allow dirt to come through the transaxle openings before transaxle mounting onto the vehicle. (including electronic part connector)**

**AUTOMATIC TRANSAXLE SYSTEM**

- Using SST(09431-39000), install the driveshaft oil seal on the transaxle case(B).

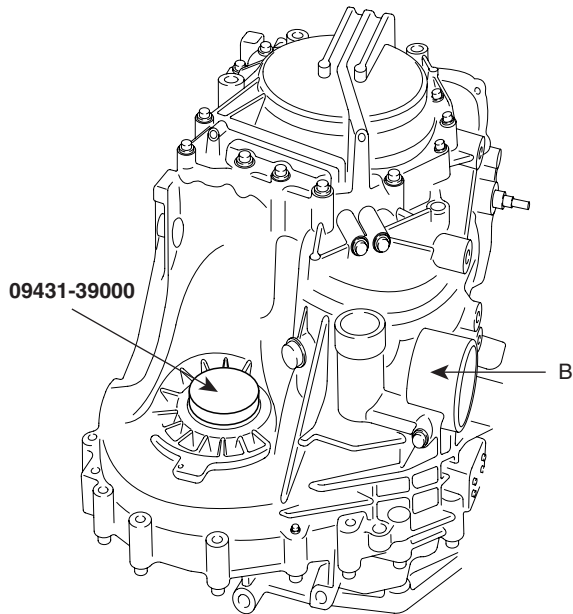

KKCF005A

- Apply ATF on the torque converter housing(A) and install 2 guide(dowel) pins(B).

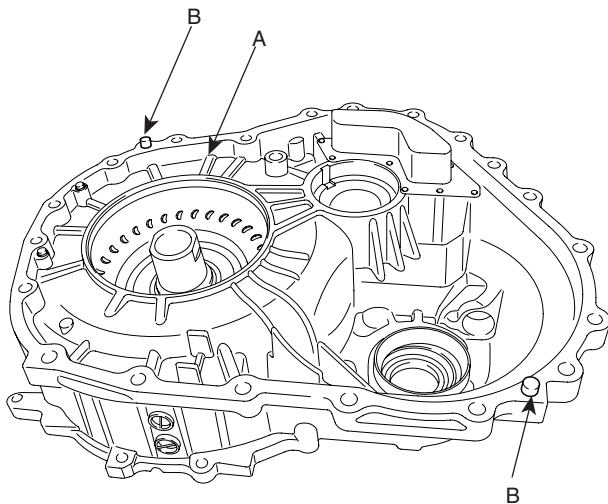

KKCF005T

- Install the transfer drive gear(A). Tighten the transfer drive gear mounting bolts(8EA) with the specified torque below.

**TORQUE:**

31.4~ 36.3 Nm(320~370 Kgf.cm, 23.1~26.8 lb-ft)

**NOTE**

Turn the transfer drive gear one revolution and ensure no interference with bolts.

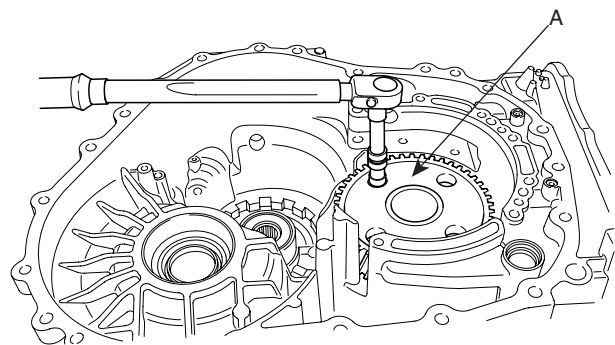

KKCF004L

- Install the two seal rings(B) and needle roller bearing(A).

**NOTE**

Do not replace the rear bearing if there's no faulty after checking because the transaxle case may be damaged in replacing the rear bearing.

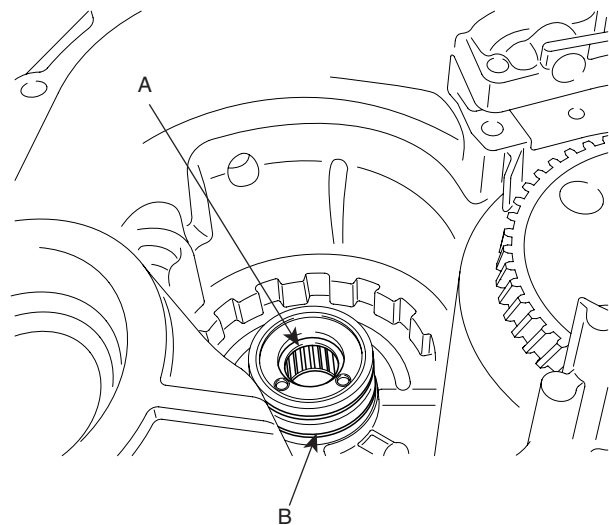

KKCF004K

5. Install the one way clutch(B) and hold it with a snap ring(A).

**NOTE**

Be cautious to the direction of the one way clutch. Line marked side(C) shall be located forward. (see figure).

6. After applying grease, install the low & reverse brake piston(B) and the return spring(A). When installing the piston, align the grooves(C).

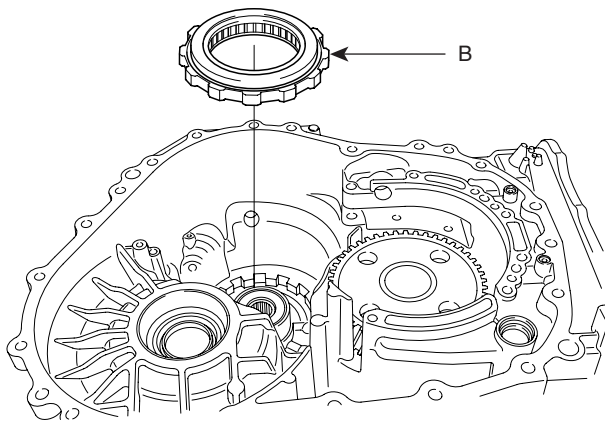

KKCF004J

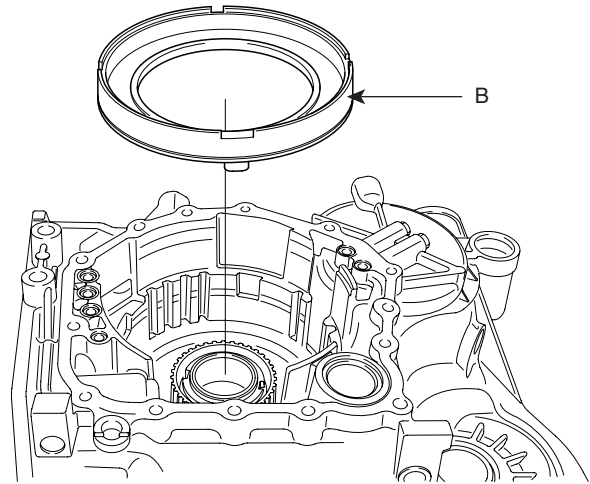

KKCF004H

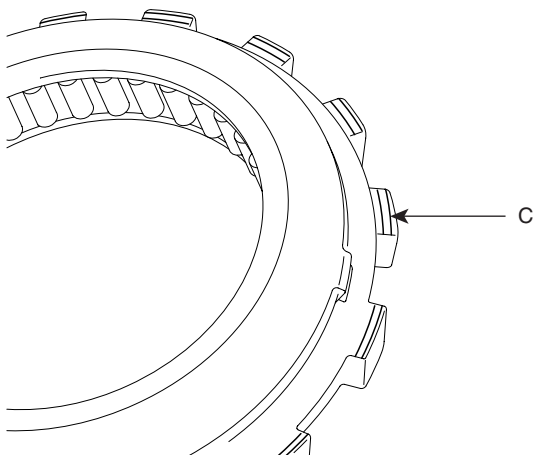

KKCF005B

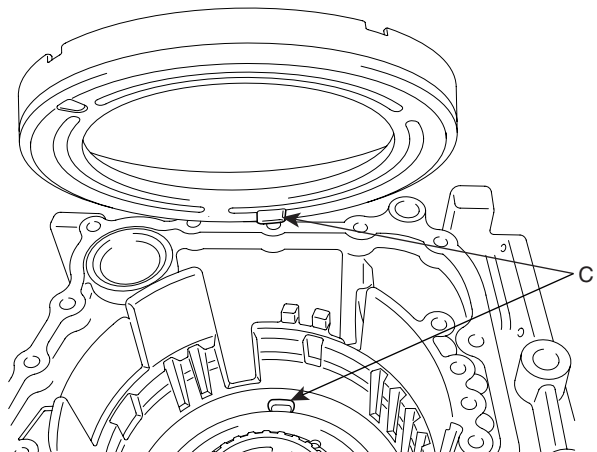

KKCF005C

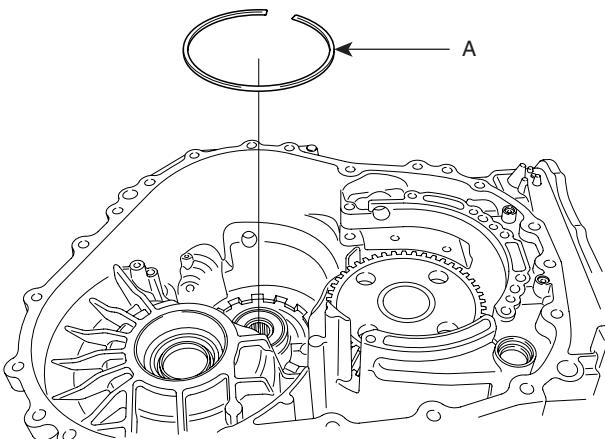

KKCF004I

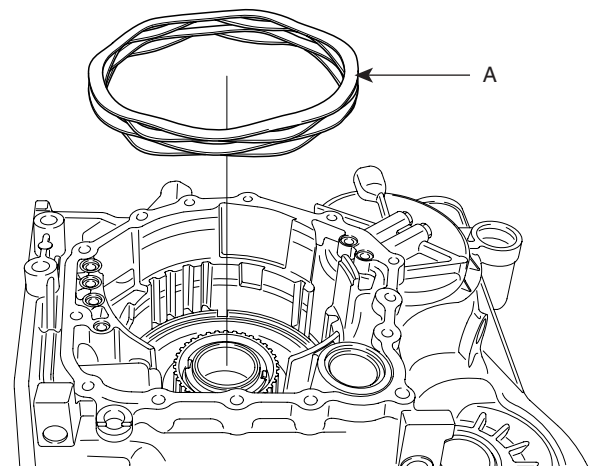

KKCF004G

7. Install the spring retainer(B), the one way clutch inner race(A) and a snap ring.

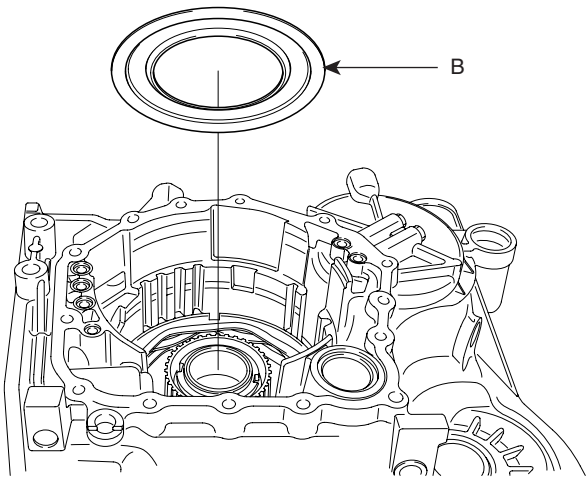

KKCF004F

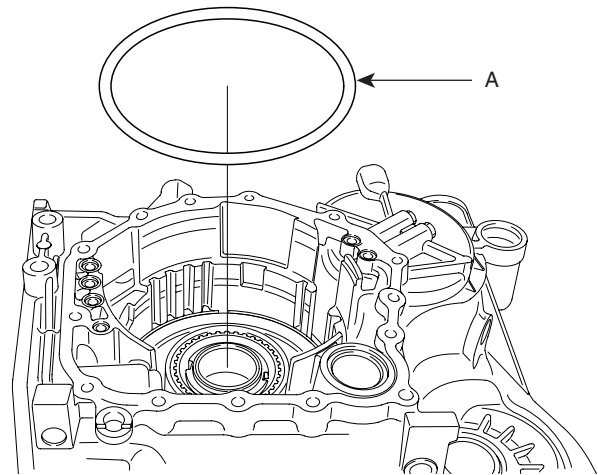

KKCF004C

9. Install the brake discs and plates in the sequence below in order to decide the acceptable brake pressure plate satisfying LR brake end play.  
 [UP] SST(09456-39100)→ Disc 2EA→ Plate→ Disc→ Plate→ Disc→ Plate→ Disc→ Plate→ Disc→ Plate [DOWN]

10. After installing the brake reaction plate, fix the snap ring (thickness:2.3mm) upon it. (It is fine that there is no snap ring under the plate ONLY when measuring.)

11. Applying 49N(5Kgf,11lbf) weight(A) on the plates and discs and 245.17kPa(2.5 Bar, 35.56psi) pressure(B) through the valve body line, measure the end play with a dial gauge.

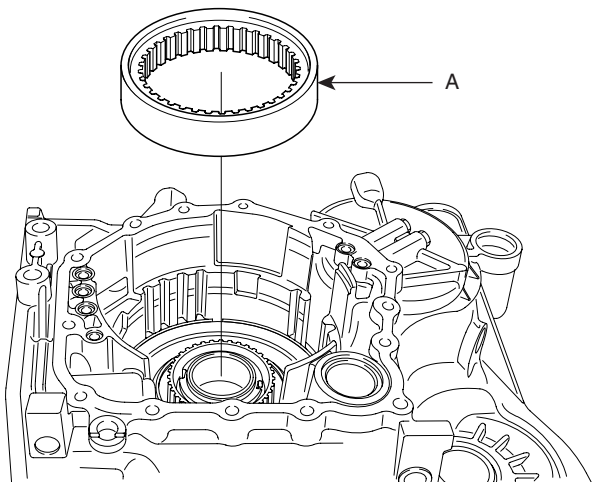

KKCF004E

8. Install the wave spring(A).

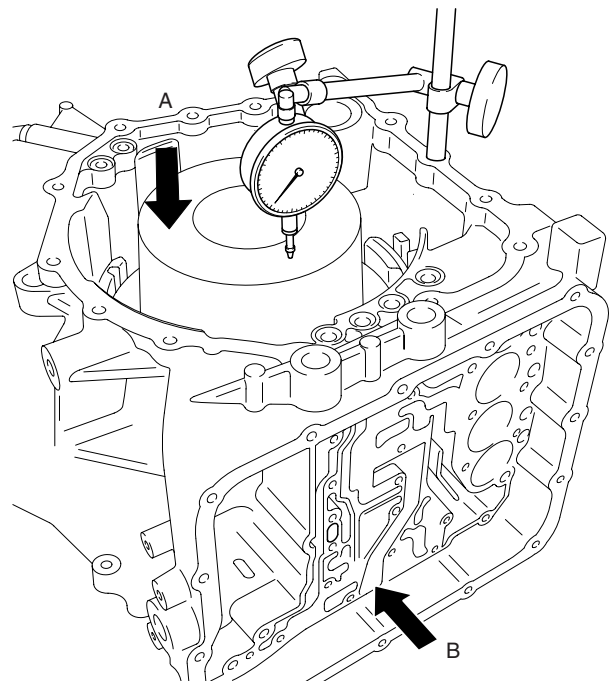

KKCF005D

12. With the formula and the table below, select the adequate low & reverse pressure plate.  
Equation: Pressure plate thickness = Travel(A)+SST thickness(1.9mm)-End play

End play: 1.65 ~ 2.11mm(0.0650~0.0831inch)

Part No.	Thickness (mm/inch)
45643-39516	1.6/0.0630
45643-39518	1.8/0.0709
45643-39520	2.0/0.0787
45643-39522	2.2/0.0866
45643-39524	2.4/0.0945
45643-39526	2.6/0.1024
45643-39528	2.8/0.1102
45643-39530	3.0/0.1182

13. After disassembling the SST(09456-39100), snap ring, brake reaction plate and brake plates(5EA) & discs(6EA) again, install the low & reverse pressure plate selected above.
14. Install the brake plates(5EA) & discs(6EA), snap ring and reaction plate in order below.  
[UP] Reaction plate→ Snap ring(thickness: 2.0mm)→ Disc→ Plate→ Disc→ Plate→ Disc→ Plate→ Disc→ Plate→ Disc [DOWN]

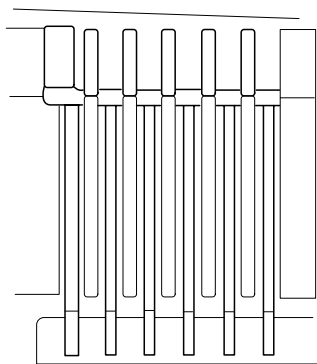

KKCF005U

15. Afterwards, measuring the gap of reaction plate, select and install the proper snap ring which satisfy the end play condition below.

End play: 0 ~ 0.16mm(0~0.0063inch)

Part No.	Thickness(mm/inch)
45665-39500	2.0/0.0787
45665-39522	2.2/0.0866
45665-39523	2.3/0.0906
45665-39524	2.4/0.0945
45665-39525	2.5/0.0984

16. Disassemble the selected snap ring temporarily.
17. In order to select the brake pressure plate which satisfy the 2ND brake end play, install the brake discs & plates in order below.  
[UP] Disc(Inner disc plate)→ Dual side plate(Brake disc)→ Two plates(Outer disc plates(no.2): 2EA)→ Disc(Inner disc plate)→ Discriminating grooved plate(Outer disc plate(no.1))→ Disc(Inner disc plate)→ SST(09456-39100) [DOWN]
18. Install the 2ND brake return spring, piston(A) and snap ring.

**NOTE**

When installing, align the grooves(B) and check up for the 2nd pressure pipe seal(valve body side).

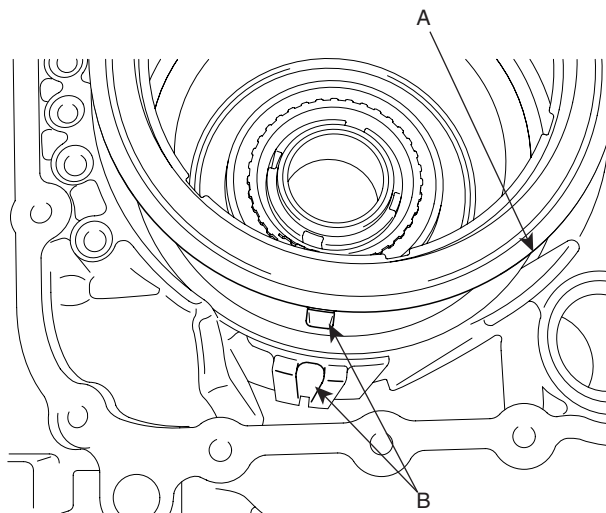

KKCF005E

**AUTOMATIC TRANSAXLE SYSTEM**

19. Applying 49N(5Kgf,11lbf) weight(A) on the plates and discs and 245.17kPa(2.5 Bar, 35.56psi) pressure(B) through the valve body line, measure the end play with a dial gauge.

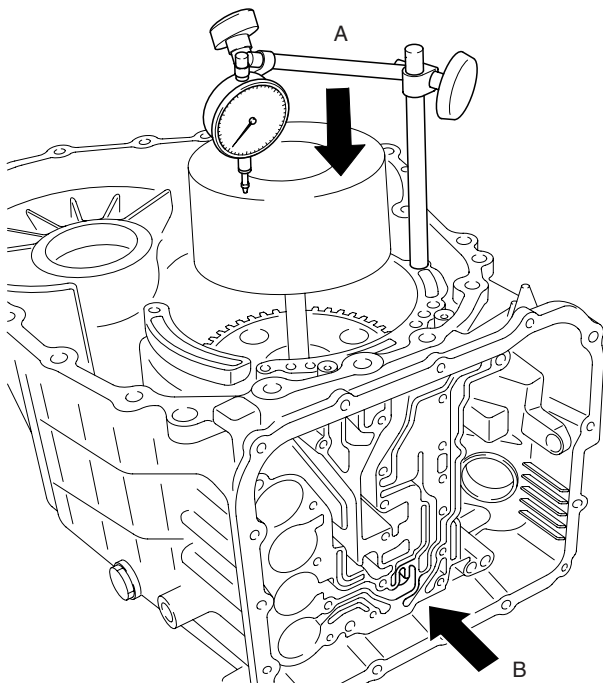

KKCF005F

20. With the formula and the table below, select the adequate 2nd brake pressure plate.  
Equation: Pressure plate thickness = Travel(A)+SST thickness(1.9mm)-End play

End play: 1.09 ~ 1.55mm(0.0429~0.0610inch)

Part No.	Thickness(mm/inch)
45643-39243	2.4/0.0945
45643-39263	2.6/0.1024
45643-39283	2.8/0.1102
45643-39303	3.0/0.1181
45643-39323	3.2/0.1260
45643-39343	3.4/0.1339

21. After disassembling the snap ring, 2ND brake piston, return spring, brake disc set(discs and plates) and SST(09456-39100) again, install the 2ND brake pressure plate selected above.

22. Install the brake plates & discs, 2nd brake piston, return spring and snap ring in order below.  
[UP] Snap ring → 2nd brake piston → Return spring → 2nd brake pressure plate → Dual side plate(Brake disc) → Plate(Outer disc plate(no.2)) → Disc(Inner disc plate) → Plate(Outer disc plate(no.2)) → Disc(Inner disc plate) → Discriminating grooved plate(Outer

disc plate(no.1)) → Disc(Inner disc plate) → Selected snap ring → Brake reaction plate [DOWN]

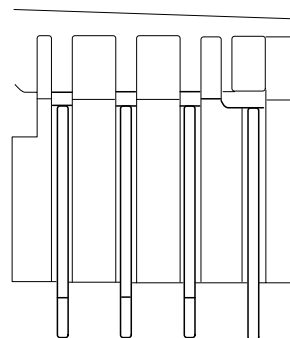

KKCF005V

23. Install the low & reverse annulus gear assembly(A).

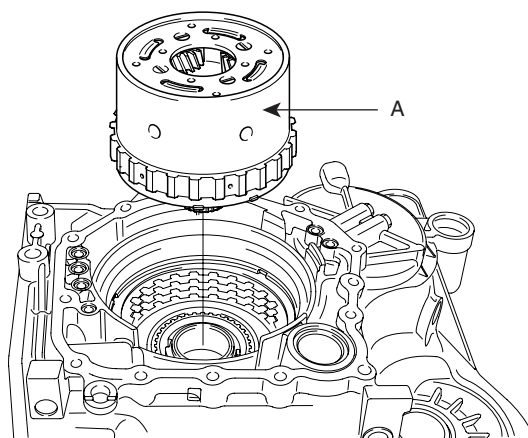

KKCF003U

24. Install the reverse sun gear assembly(A).

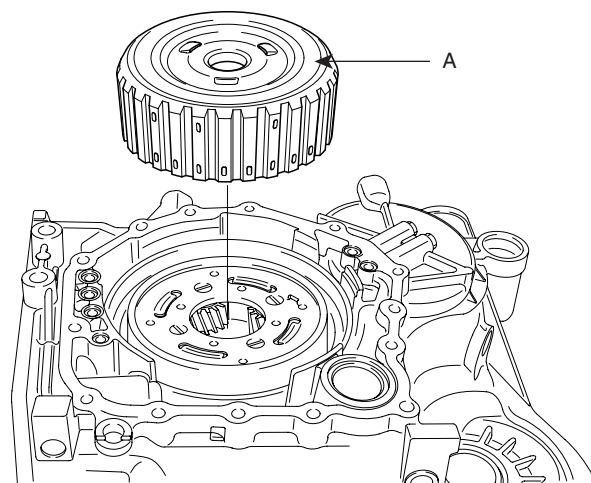

KKCF003T

25. Assemble the overdrive clutch hub(A) and the thrust bearing(B) into the reverse & overdrive clutch. Be careful not to reverse the direction of the thrust bearing.

28. Install the reduction accumulator piston assembly(A) and coil spring(B).

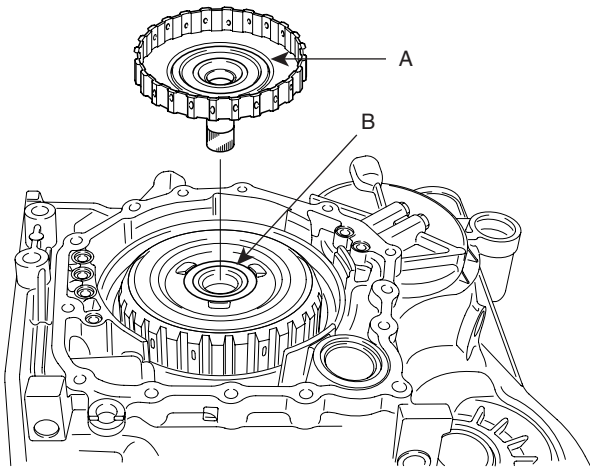

KKCF003S

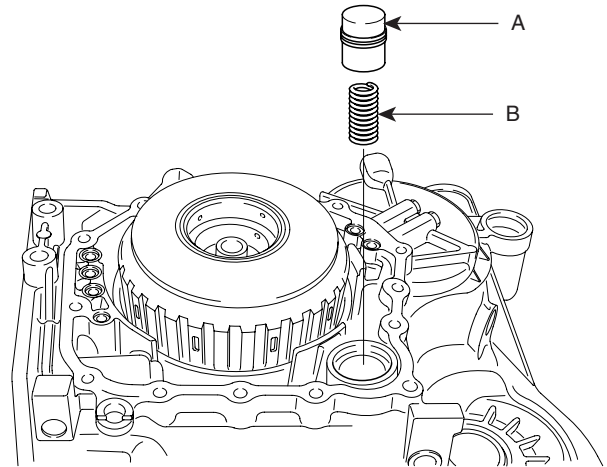

KKCF003P

26. Install the thrust bearing(A). Be careful not to reverse the direction of the thrust bearing.

29. Assemble the thrust bearing(A) and six O-rings(B), Being careful not to reverse the direction of the thrust bearing.

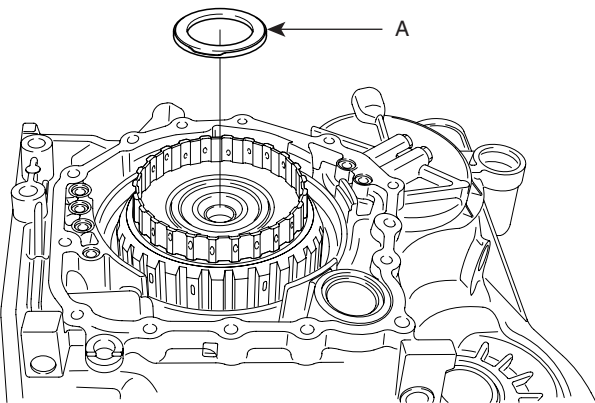

KKCF003R

27. Install the reverse & overdrive clutch assembly(A).

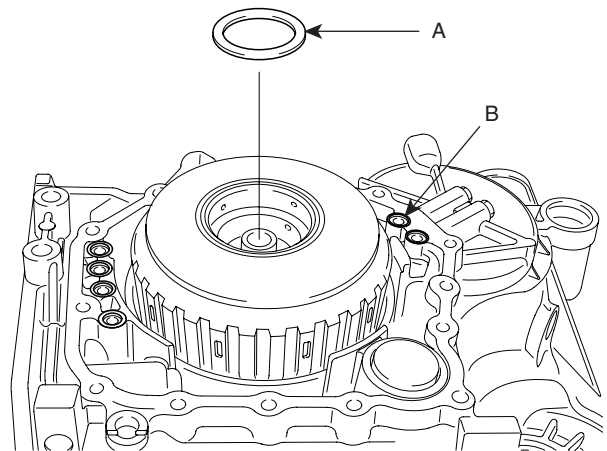

KKCF003O

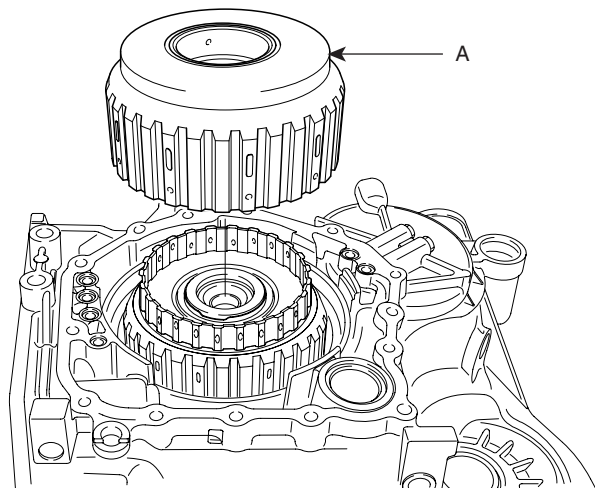

KKCF003Q

**AUTOMATIC TRANSAXLE SYSTEM**

30. In order to select the thrust race, install a dial gauge on the rear cover mountring surface and measure the depth(A) to the thrust race contacting surface and the height(B) to the thrust bearing in the reverse & over-drive clutch assembly.

Part No.	Thickness (mm/inch)	A-B(mm/inch)
45459-39168	1.6/ 0.0630	1.9~2.0/ 0.0748~0.0787
45853-39178	1.7/ 0.0669	2.0~2.1/ 0.0787~0.0827
45459-39188	1.8/ 0.0709	2.1~2.2/ 0.0827~0.0866
45853-39198	1.9/ 0.0748	2.2~2.3/ 0.0866~0.0906
45459-39208	2.0/ 0.0787	2.3~2.4/ 0.0906~0.0945
45853-39218	2.1/ 0.0827	2.4~2.5/ 0.0945~0.0984
45459-39228	2.2/ 0.0866	2.5~2.6/ 0.0984~0.1024
45853-39238	2.3/ 0.0906	2.6~2.7/ 0.1024~0.1063
45459-39248	2.4/ 0.0945	2.7~2.8/ 0.1063~0.1102
45853-39258	2.5/ 0.0984	2.8~2.9/ 0.1102~0.1142
45853-39260	2.8/ 0.1102	2.9~3.0/ 0.1142~0.1181

31. Assemble the thrust race(A) and the four seal rings(B).

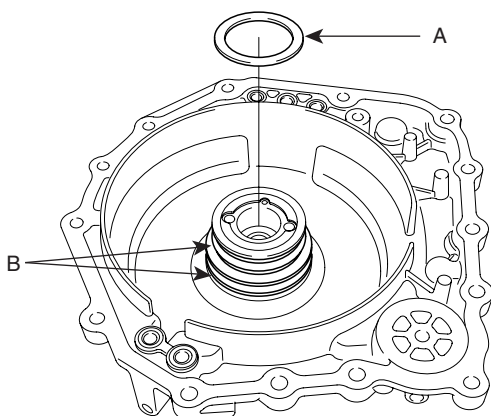

KKCF003N

32. Insert the used thrust bearing and install the rear cover(A).

**TORQUE:**  
19.6~ 25.5 Nm(200~260 Kgf.cm, 14.5~18.8 lb-ft)

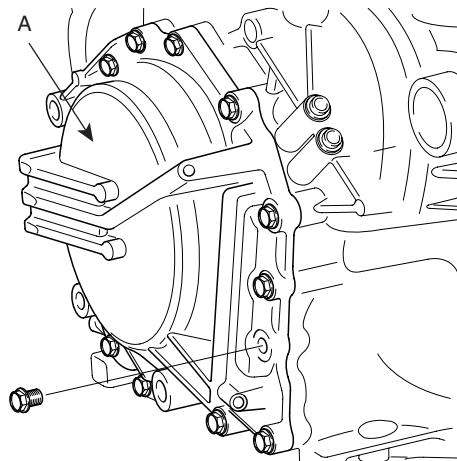

KKCF003M

**NOTE**

*Rear cover will be installed in order to check the underdrive sun gear gap.*

33. Measure the underdrive sun gear end play and check if the installed thrust race satisfies the end play condition below.

**End play:**  
0.25 ~ 0.45mm(0.0098~0.0177inch)

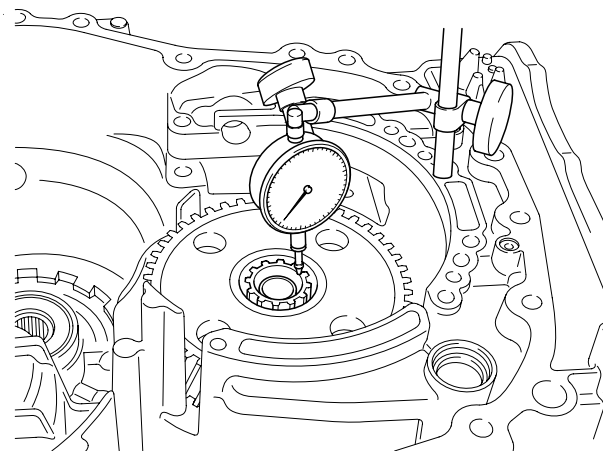

KKCF005G

## AT -34

## AUTOMATIC TRANSAXLE (A5HF1)

34. Apply liquid gasket with 1.6mm thickness on the rear cover surface without a pause and tighten the rear cover.

**TORQUE:**

19.6~ 25.5 Nm(200~260 Kgf.cm, 14.5~18.8 lb-ft)

Liquid gasket: Threebond 1281B or LOCTITE FMD-546

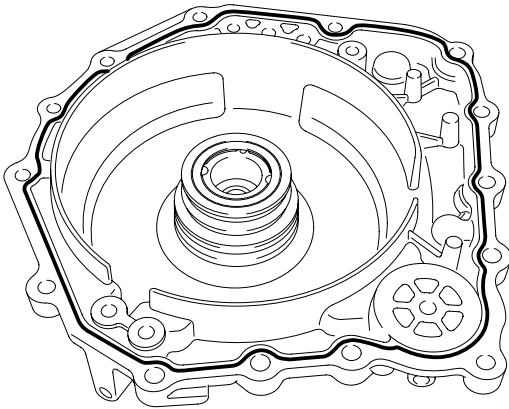

KKCF005H

35. Insert the anchor plug(B) with a hand matching into the reduction brake band hole(A).

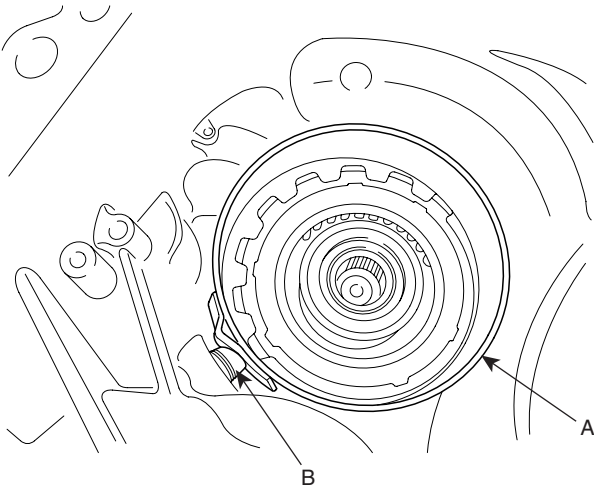

KKCF005I

36. Assemble the thrust race.

KKCF002P

37. Install the direct clutch(A) with a thrust bearing applied grease.

**NOTE**

Install the direct clutch(A), turning it counterclockwise.

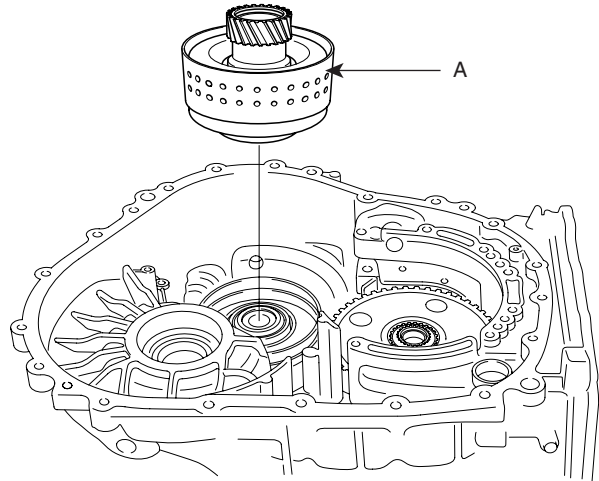

KKCF003I

38. After tightening the anchor plug with the specified torque below, assemble the reduction brake piston with a snap ring(A)(inner side).

**TORQUE:**

83.4~112.8Nm(850~1150 Kgf.cm, 61.5~83.2 lb-ft)

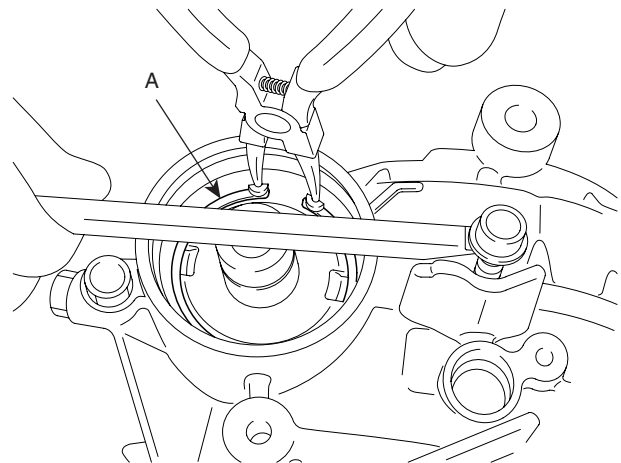

39. Install the direct planetary carrier assembly(A).

**NOTE**

Look into the hole where the output speed sensor will be installed, in order to check if direct planetary carrier assembly is seated correctly.

**CAUTION**

On moving the transaxle case, be careful that the direct clutch assembly will not slide out.

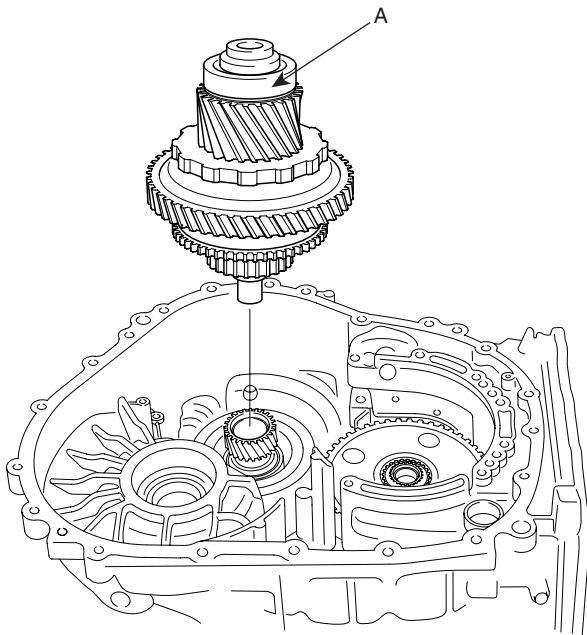

KKCF003H

40. Install the parking sprag(A), spring(B) and then the parking sprag shaft.

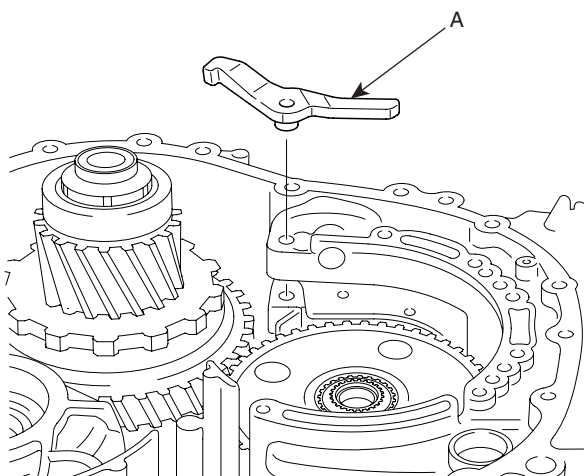

KKCF003G

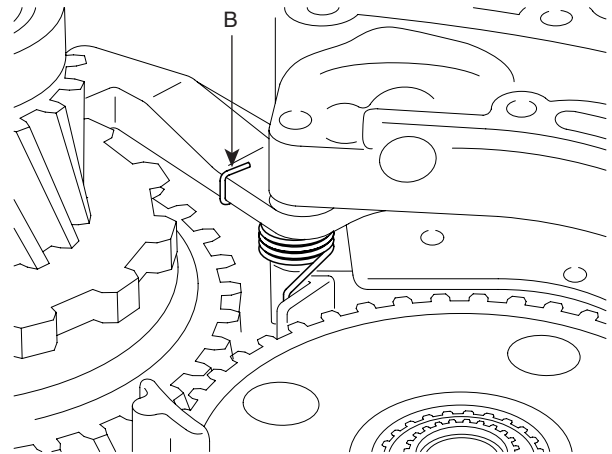

KKCF003F

41. Install the parking roller support(A) and the roller shafts(B)(2EA).

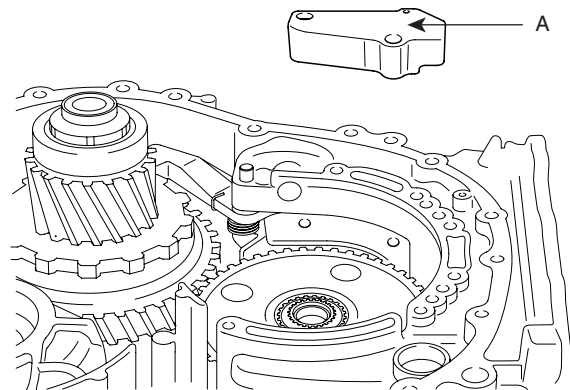

KKCF003D

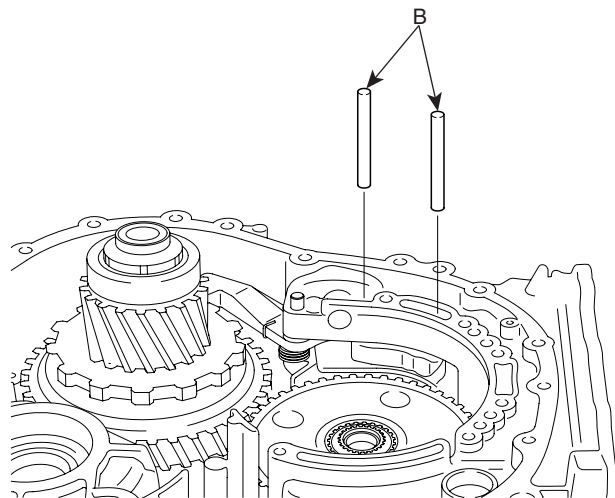

KKCF003C

42. Install the underdrive clutch hub(A).

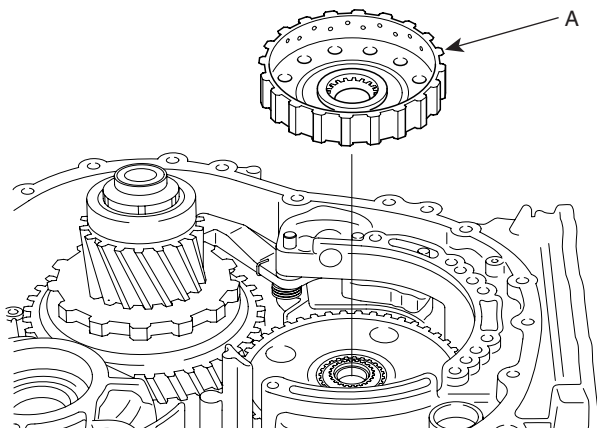

KKCF003B

43. Assemble the thrust bearing(A) and install the underdrive clutch(B) with the input shaft.

**CAUTION**

*Be careful not to reverse the direction of the thrust bearing.*

**NOTE**

*Look into the hole where the input speed sensor will be installed, in order to check if the underdrive clutch is seated correctly.*

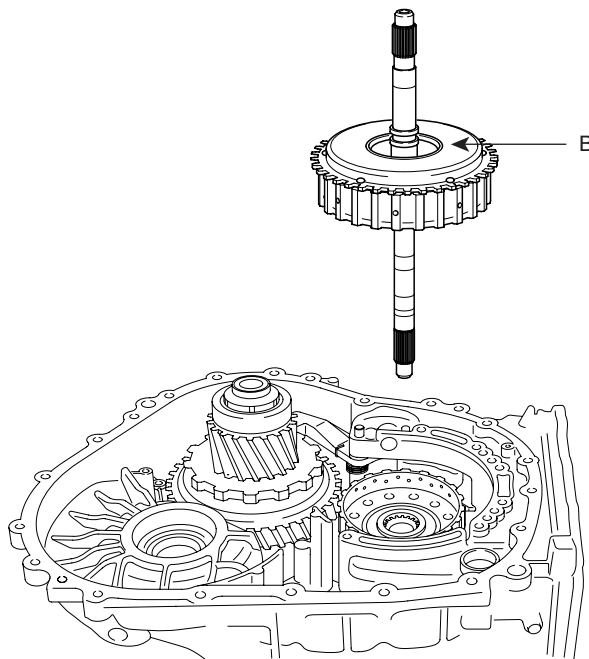

KKCF002Z

44. Install the used thrust washer(A).

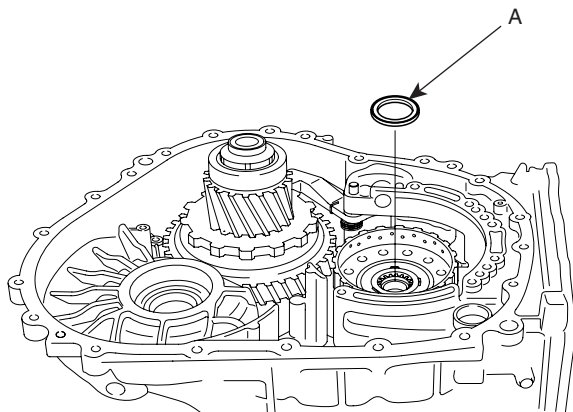

KKCF003A

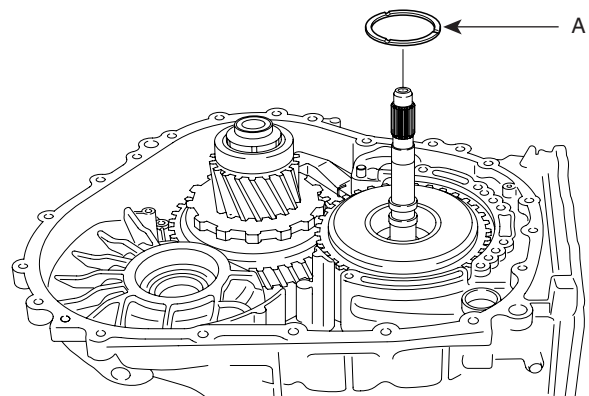

KKCF002Y

45. Connect the pipe to the oil pump and install the oil pump with a new oil pump gasket.

**TORQUE:**  
9.8~11.8Nm(100~120 Kgf.cm, 7.2~8.7 lb-ft)

**CAUTION**

*Do not reuse the used gasket.*

**AUTOMATIC TRANSAXLE SYSTEM**

46. Tighten the oil pump mounting bolt(A) with the TORQUE.

**TORQUE:**  
19.6~25.5Nm(200~260 Kgf.cm, 14.5~18.8 lb-ft)

Tighten the oil pump pipe mounting bolt(B) with the TORQUE.

**TORQUE:**  
9.8~11.8Nm(100~120 Kgf.cm, 7.2~8.7 lb-ft)

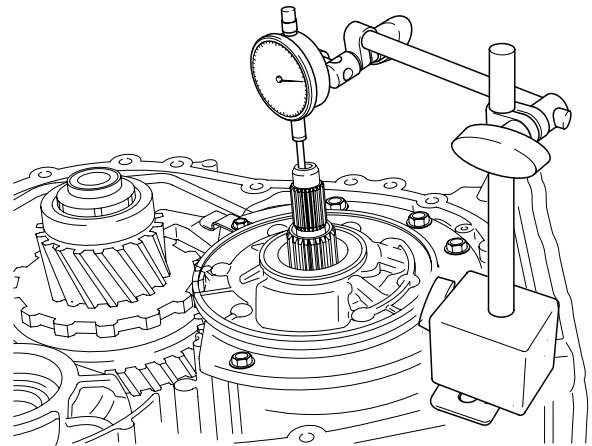

KKCF005K

48. Install the two O-rings(A) and the main oil filter(B).

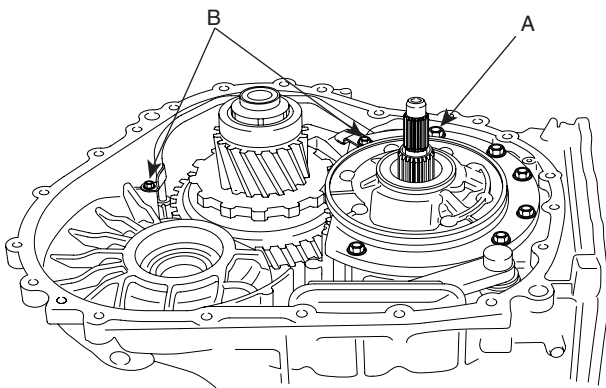

KKCF002X

47. Check the input shaft end play and replace the thrust washer which was installed in the step 43 with the appropriate thrust washer from the table below.

End play: 0.70 ~ 1.45mm(0.0276~0.0571inch)

Part No.	Thickness (mm/inch)
45544-39180	1.8/0.0709
45544-39200	2.0/0.0787
45544-39220	2.2/0.0866
45544-39240	2.4/0.0945
45544-39260	2.6/0.1024
45544-39280	2.8/0.1102

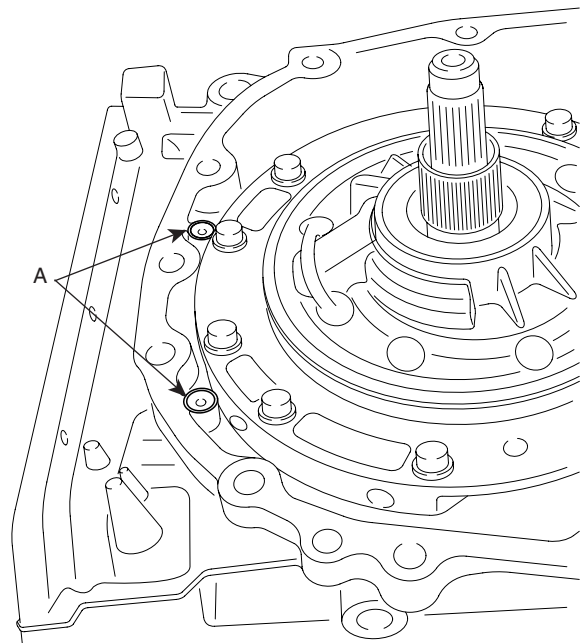

KKCF002U

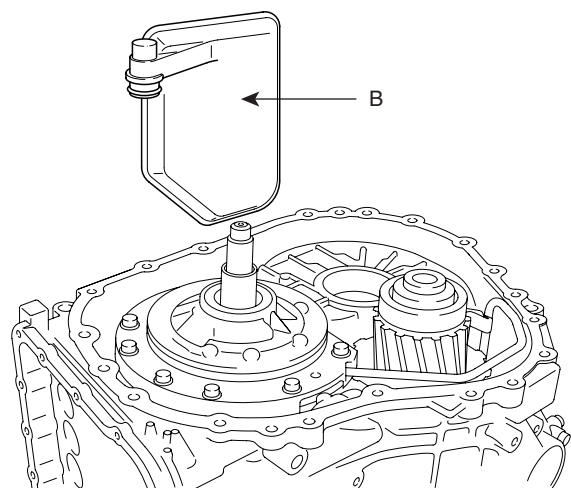

KKCF002W

49. Install the differential assembly(A).

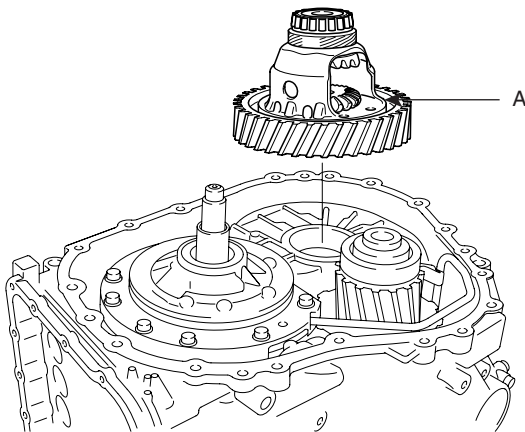

KKCF002V

50. With a dial gauge(C), set the torque converter housing mounting surface(B) as its zero point and measure the depth(A') to the differential spacer contacting surface.

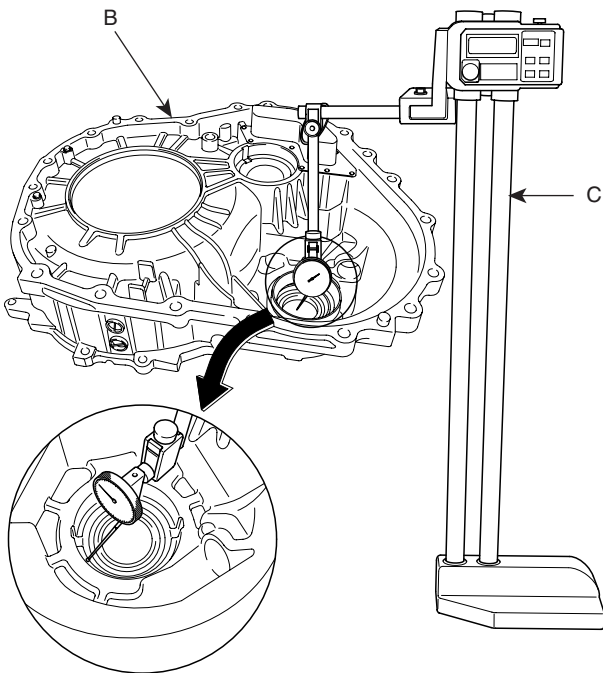

KKCF005M

51. After installing the differential outer races(A)(2EA-both sides), measure the total differential(B) length(C').

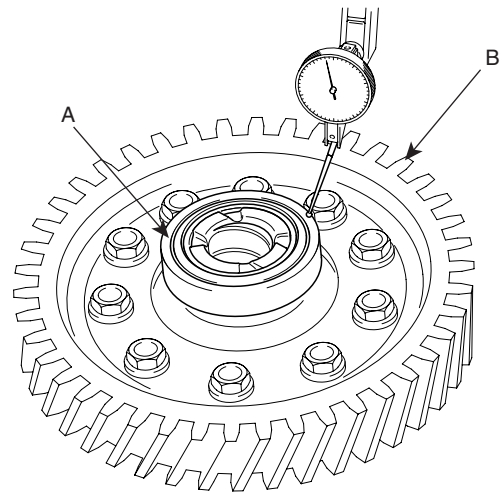

KKCF005N

52. Measure the depth(B') from the transaxle case mounting surface(A) to the differential outer race contacting surface(C).

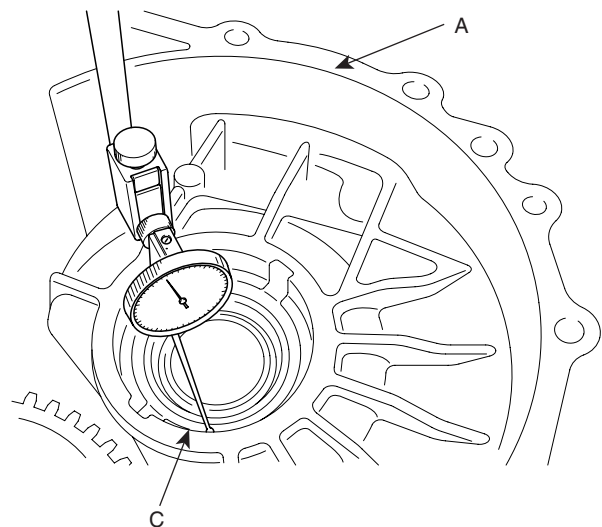

KKCF005O

**AUTOMATIC TRANSAXLE SYSTEM**

53. With the measured data(A',B' and C') in the steps 49~51, select the appropriate differential bearing spacer by the equation below.

Equation: Spacer thickness = A'+B'-C'+End play

End play: 0.045 ~ 0.105mm(0.0018~0.0041inch)

Part No.	Thickness (mm/inch)	Identification mark
45849-39883	0.83/ 0.0327	83
45849-39886	0.86/ 0.0339	86
45849-39889	0.89/ 0.0350	89
45849-39892	0.92/0.0362	92
45849-39895	0.95/0.0374	95
45849-39898	0.98/0.0386	98
45849-39801	1.01/0.0398	01
45849-39804	1.04/0.0409	04
45849-39807	1.07/ 0.0421	07
45849-39810	1.10/ 0.0433	10
45849-39813	1.13/ 0.0455	13
45849-39816	1.16/ 0.0457	16
45849-39819	1.19/ 0.0469	19
45849-39822	1.22/ 0.0480	22
45849-39825	1.25/ 0.0492	25
45849-39828	1.28/ 0.0504	28
45849-39831	1.31/ 0.0516	31
45849-39834	1.34/ 0.0528	34
45849-39837	1.37/ 0.0539	37

54. Apply liquid gasket at the torque converter housing at Ø1.6mm thickness as the figure without a pause.

Liquid gasket: Threebond 1281B or LOCTITE FMD-546

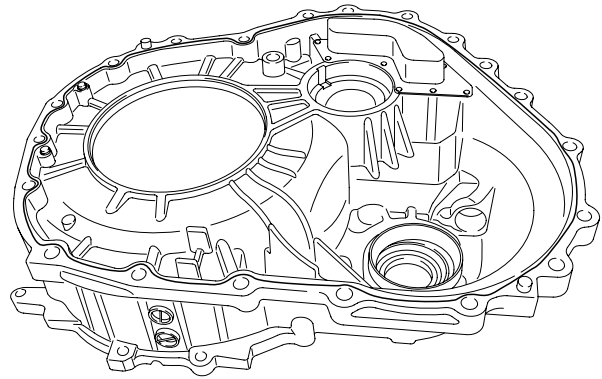

KKCF005P

55. Install the torque converter housing(A) and tighten the connecting bolts(B)(20EA) with the TORQUE.

**TORQUE:**  
42~54Nm(428~551 Kgf.cm, 31.0~39.9 lb-ft)

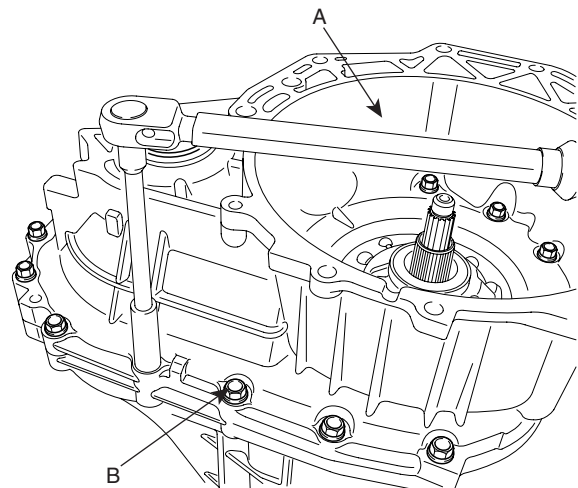

KKCF005Q

## AT -40

## AUTOMATIC TRANSAXLE (A5HF1)

56. Applying grease to the O-rings(2EA) of the manual control shaft(B), install the parking roller rod(C), manual control shaft(B) and the shaft(A).

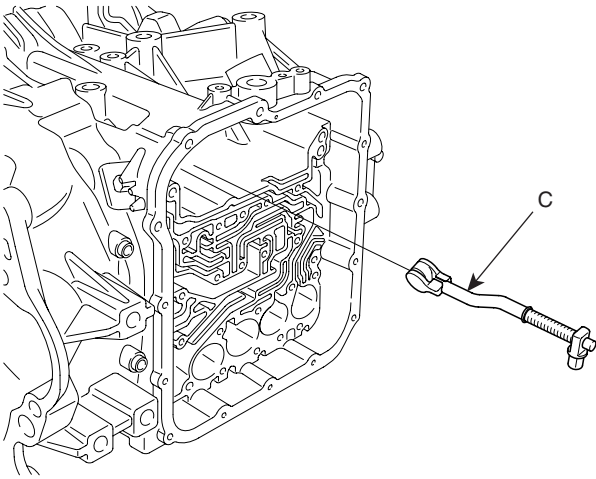

KKCF002T

57. Install the reduction brake accumulator(D), spring(C), piston(B) and then the snap ring(A).

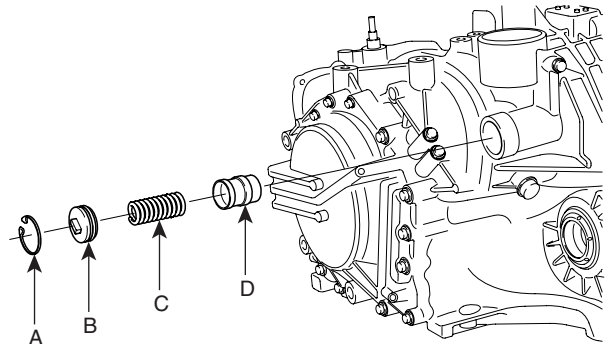

KKCF002N

58. Install each accumulator piston, a new seal ring, and the spring.

**NOTE**

*Accumulator spring identification.*

No.	Use	I.D.Color
1	LR brake	Colorless
2	UD clutch	Yellow
3	2ND brake	White
4	OD clutch	Colorless

59. Install the strainer and the second brake retainer oil seal.

60. Install the solenoid valve harness and the snap ring around the connector tightly.

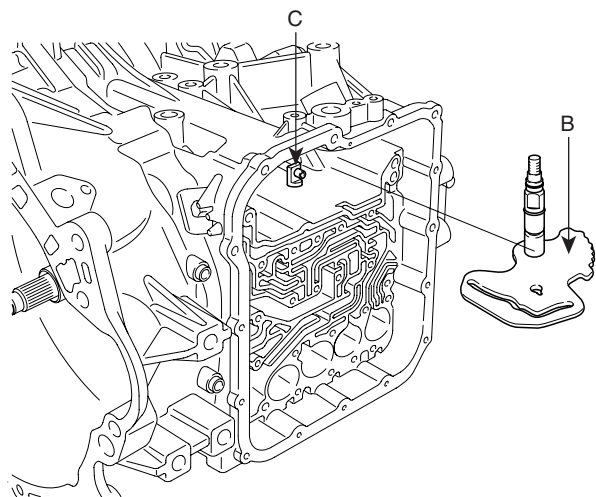

KKCF002S

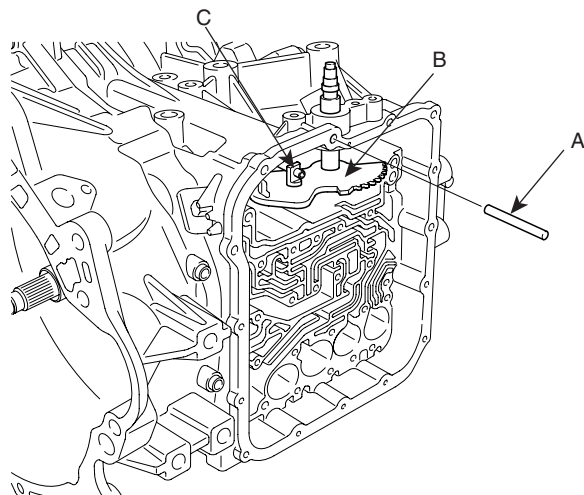

KKCF002R

**AUTOMATIC TRANSAXLE SYSTEM**

61. Install the valve body(A) and tighten the mounting bolts(28EA).

**TORQUE:**  
9.8~11.8Nm(100~120 Kgf.cm, 7.2~8.7 lb-ft)

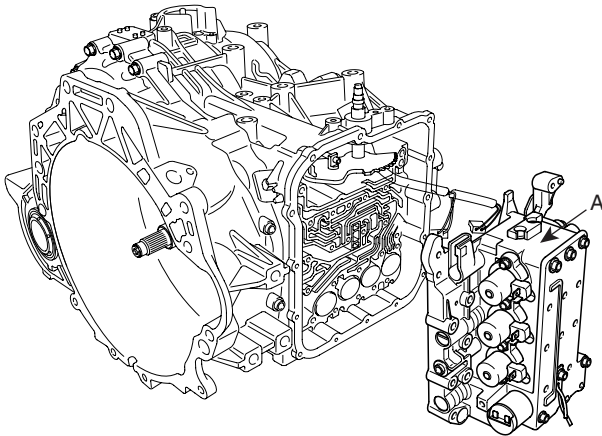

KKCF002I

62. Install the VFS(variable force solenoid) reservoir.

**TORQUE:**  
9.8~11.8Nm(100~120 Kgf.cm, 7.2~8.7 lb-ft)

63. Enlink the connector harness to the connector and the oil temperature sensor of the valve body.

No.	Connecting point	Wire color	Connector housing color
1	OD solenoid valve	Orange, Red	Black
2	UD solenoid valve	White, Red, Red	Black
3	LR solenoid valve	Brown, yellow	Milky white
4	2nd solenoid valve	Green, Red, Red	Milky white
5	RED solenoid valve	Brown, Yellow, Yellow	Black
6	DCC solenoid valve	Blue, Yellow, Yellow	Black
7	VFS	Brown, Orange	Black
8	Temperature sensor	Black, Red	Black

64. Install the manual control shaft detent spring(A).

**TORQUE:**  
4.9~6.9 Nm(50~70 Kgf.cm, 3.6~5.1 lb-ft)

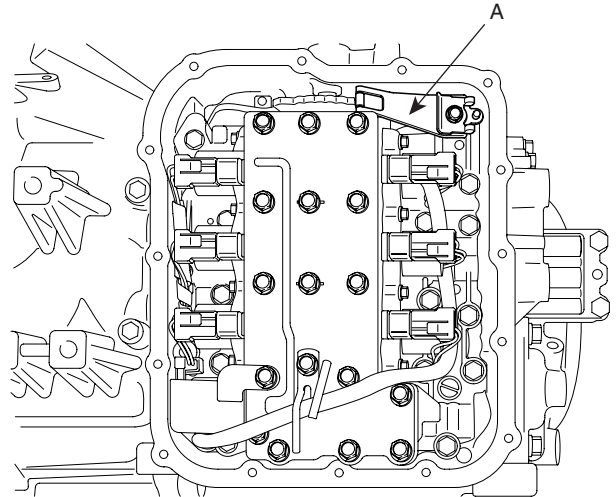

KKCF002F

65. Apply liquid gasket(A) at the valve body cover(B) at 2.5mm thickness as the figure without a pause.

**Liquid gasket: Threebond 1281B or LOCTITE FMD-546**

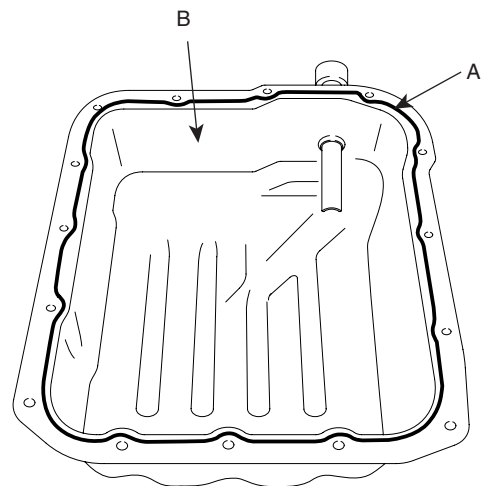

KKCF005R

AT -42

AUTOMATIC TRANSAXLE (A5HF1)

66. Install the valve body cover(A) and tighten the mounting bolts with the TORQUE.

TORQUE:

9.8~11.8Nm(100~120 Kgf.cm, 7.2~8.7 lb-ft)

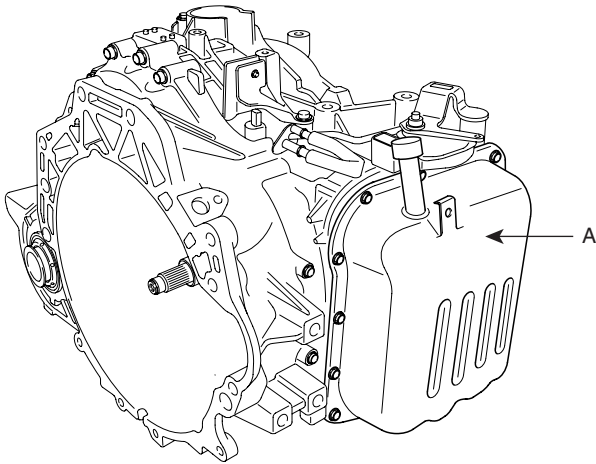

KKCF002E

67. Install the vehicle speed sensor(A).

TORQUE:

3.9~5.9Nm(40~60 Kgf.cm, 2.9~4.3 lb-ft)

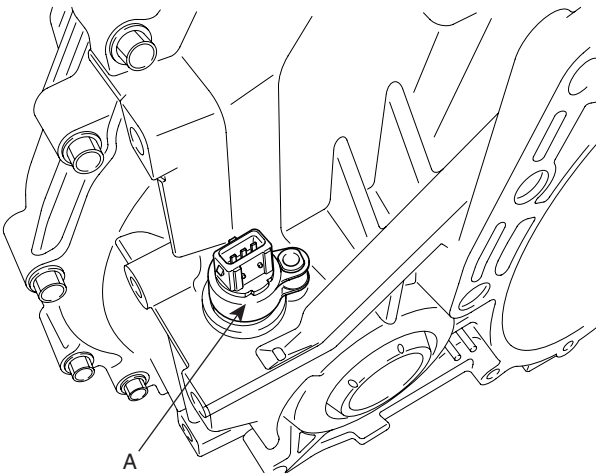

KKCF002D

68. Install the inhibitor switch(A) and the manual control lever(B).

TORQUE:

9.8~11.8Nm(100~120 Kgf.cm, 7.2~8.7 lb-ft) - A

17.7~24.5Nm(180~250 Kgf.cm, 13.0~18.1 lb-ft) - B

**!** CAUTION

*The inhibitor switch should be installed with the valve body installed as it was.*

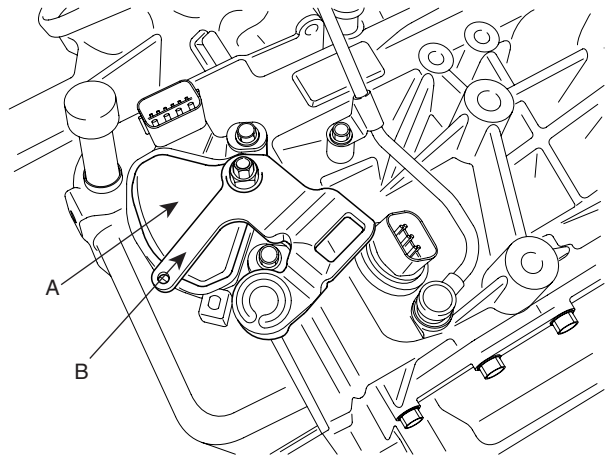

KKCF002C

69. Install the input(A) and the output speed sensors(B).

TORQUE:

9.8~11.8Nm(100~120 Kgf.cm, 7.2~8.7 lb-ft)

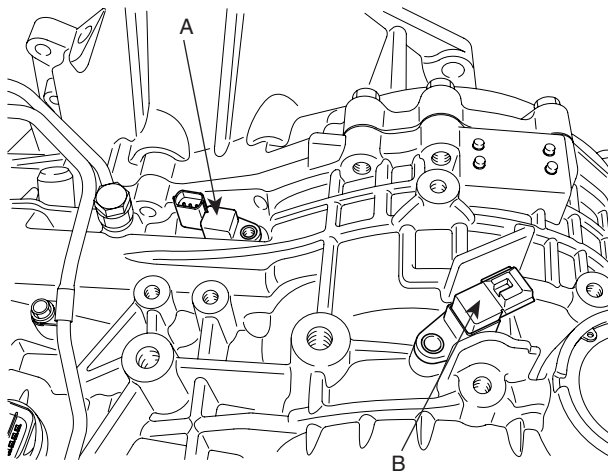

KKCF002B

- 70. Install the eyebolt, a new gasket and the oil cooler feed tube.
- 71. Install the oil level gauge.
- 72. Install each bracket.
- 73. Adjust the rejunction brake band by the reduction brake piston which was installed in the step 37.
  - 1) Fix the reduction brake piston not to rotate. Using the SST(09454-3A110), tighten/release the adjusting rod with the specified torque(9.8Nm(100Kgf.cm, 7.2lb-ft)) twice.

- 74. Insert the outer reduction brake piston(B) and the snap ring(A).

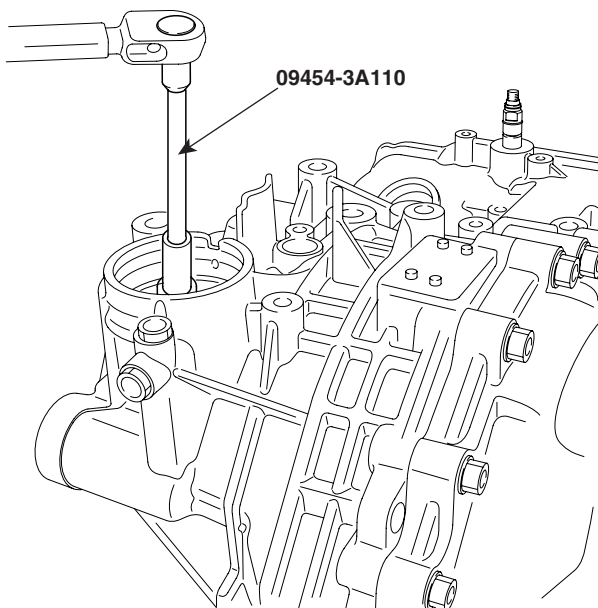

KKCF005S

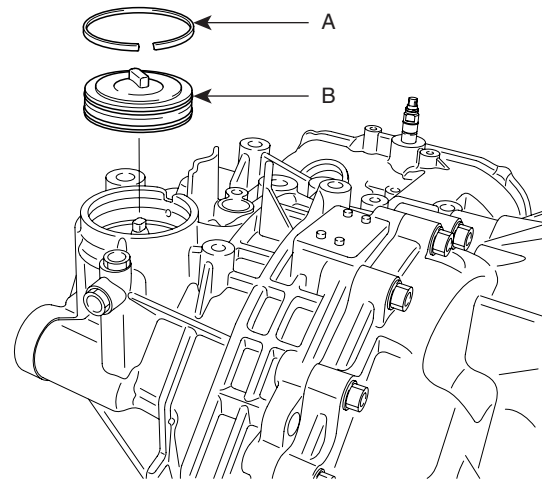

KKCF002O

- 2) Tighten it with the specified torque (4.9Nm(50Kgf.cm, 3.6lb-ft)) and turn it to loose until its 5.5~5.75 revolution.
- 3) Tighten the reduntion brake piston rod fixing nut with the specified torque.

---

**TORQUE:**  
14.7~24.5Nm(150~250 Kgf.cm, 10.8~18.1 lb-ft)

---

**LOW & REVERSE BRAKE**

**COMPONENTS** EF3897D2

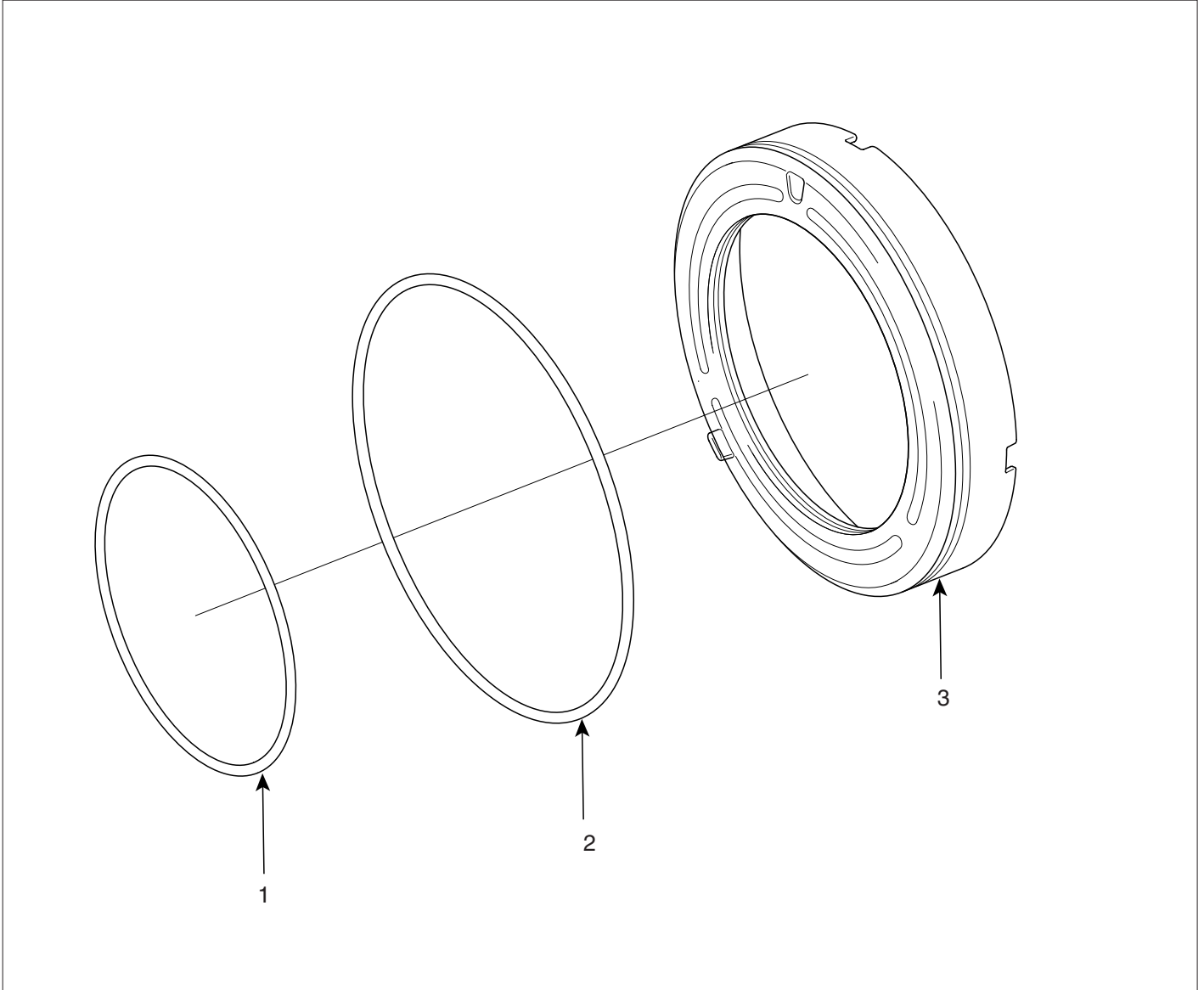

- 1. D-ring(inner)
- 2. D-ring(outer)
- 3. Low & Reverse brake piston

EKRF503A

**DISASSEMBLY** E01A2E8B

- 1. Remove the D-rings(2EA) from the inner and outer surface of the low & reverse brake.

**REASSEMBLY** EE51ADC1

- 1. Apply ATF or white vaseline on the D-rings in order not to be damaged.

**OIL PUMP (A/T)**

**COMPONENTS** E86D3F1E

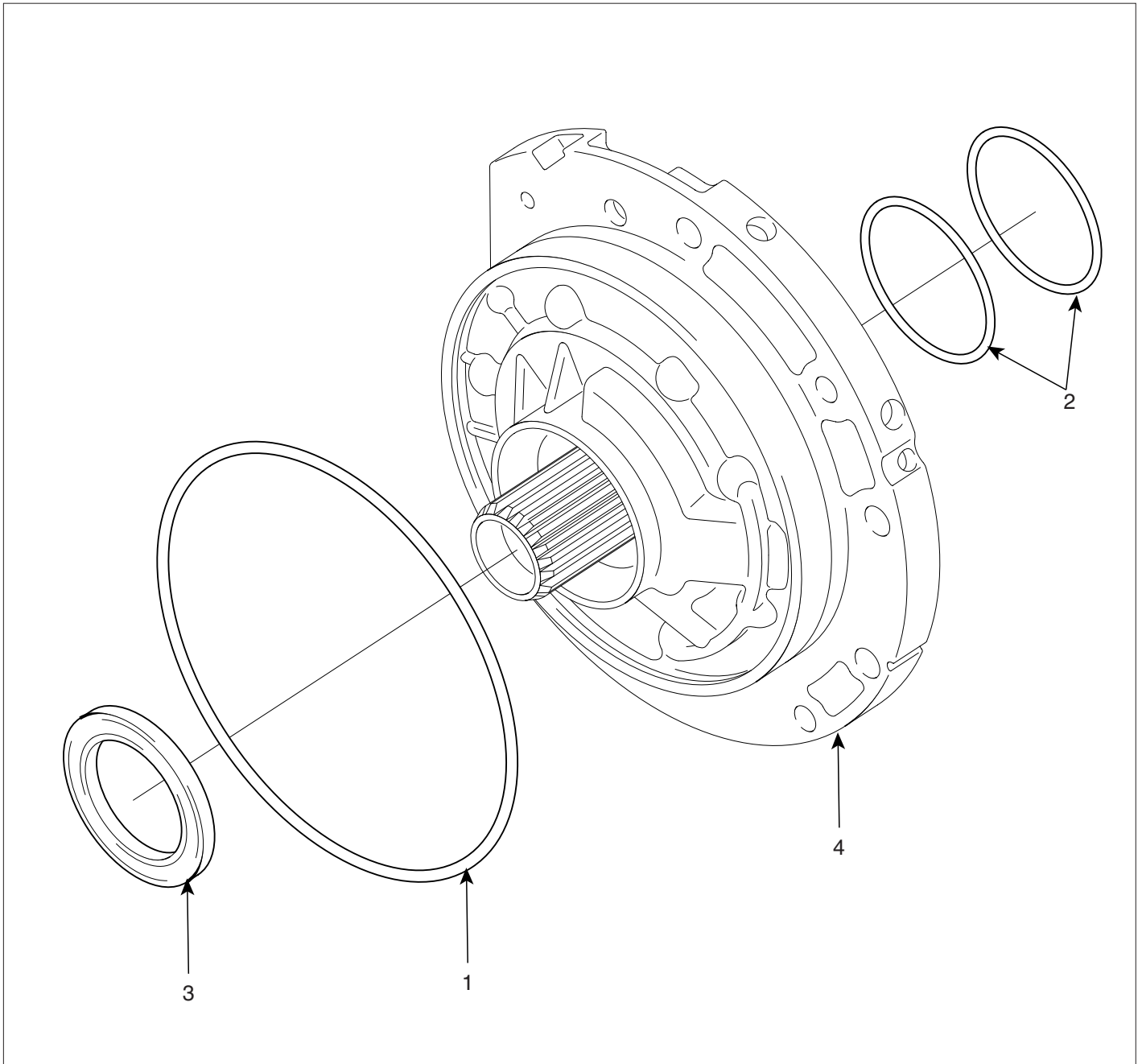

- 1. O-ring
- 2. D-ring

- 3. Oil seal
- 4. Oil pump

EKRF501A

**DISASSEMBLY** E42E422F

1. Separate the O- ring(A).

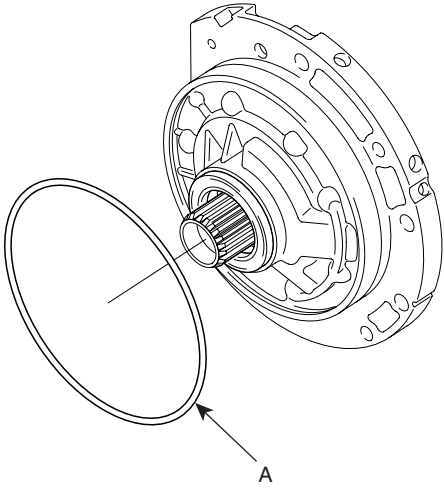

KKCF006B

2. Separate the seal rings(A)(2EA).

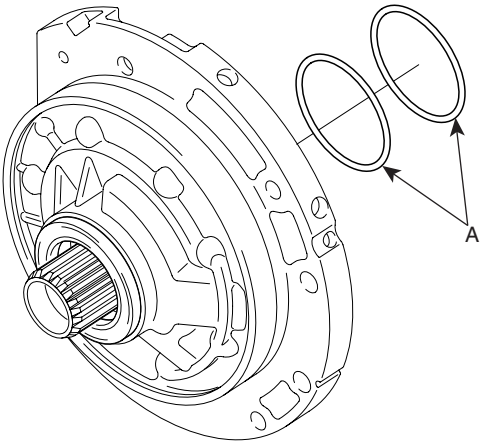

KKCF006C

3. Separate the oil seal.

**REASSEMBLY** EF29A9C9

Reassembly is in the reverse order of disassembly. O-rings, seal rings or oil seals should be replaced with new ones.

At oil seal installation, take care so that leakage occurrence may not happen using SST(09452-21200).

**PLANETARY GEAR SET**

**COMPONENTS** EC92C657

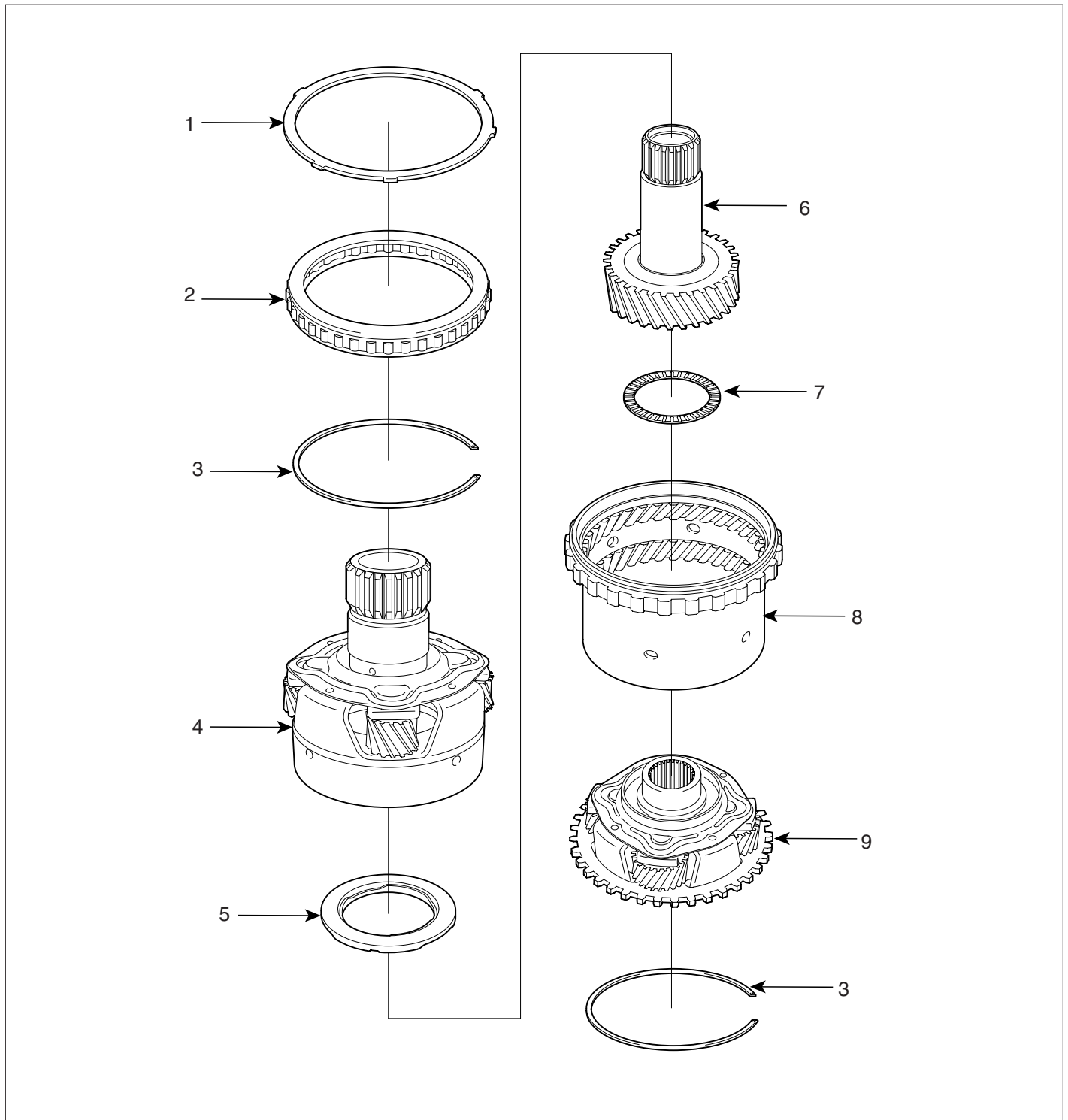

- 1. Stopper plate
- 2. Oneway clutch
- 3. Snap ring
- 4. Output planetary carrier assembly
- 5. Thrust bearing

- 6. Under drive sun gear
- 7. Thrust bearing
- 8. Low&Reverse annulus gear
- 9. Overdrive planetary carrier assembly

**DISASSEMBLY** EBC6EC02

1. Remove the stopper plate(A).

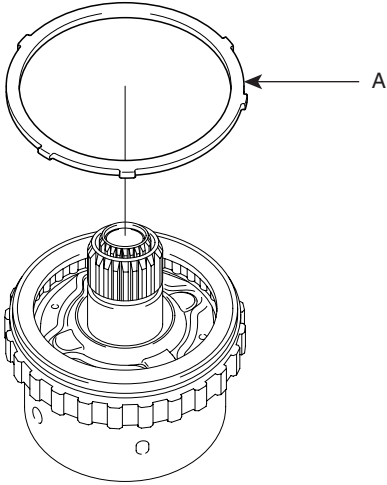

KKCF016B

2. Remove the one way clutch(A).

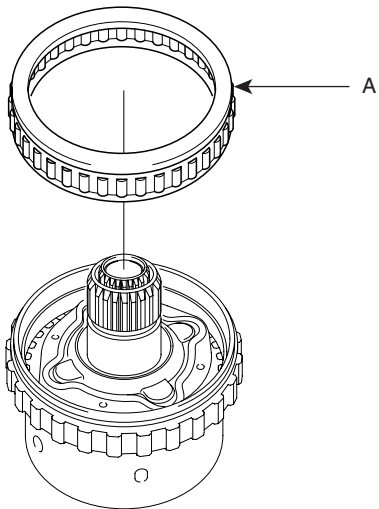

KKCF016C

3. Remove the snap ring(A).

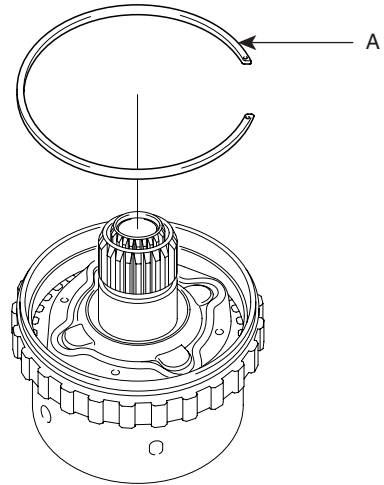

KKCF016D

4. Remove the output planetary carrier assembly(A).

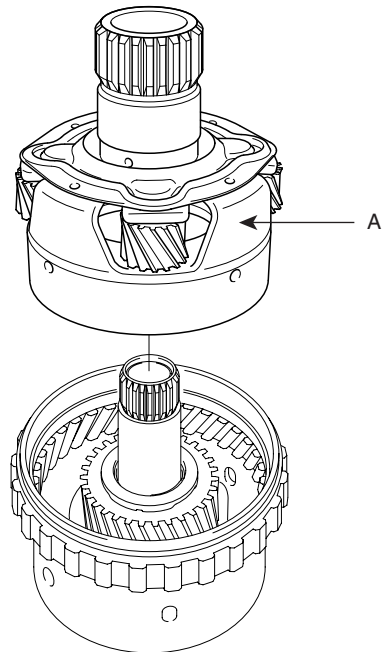

KKCF016E

5. Remove the thrust bearing(A).

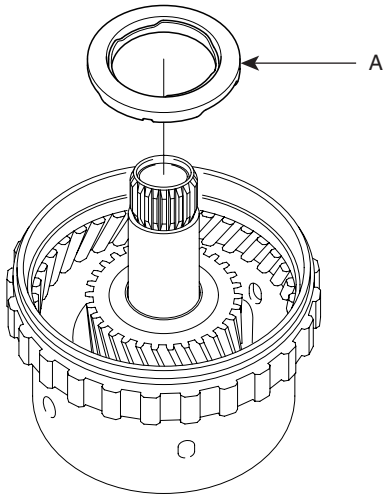

KKCF016F

7. Remove the thrust bearing(A).

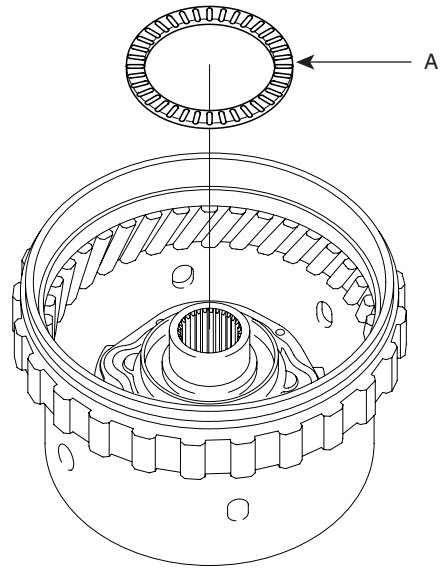

KKCF016H

6. Remove the underdrive sun gear(A).

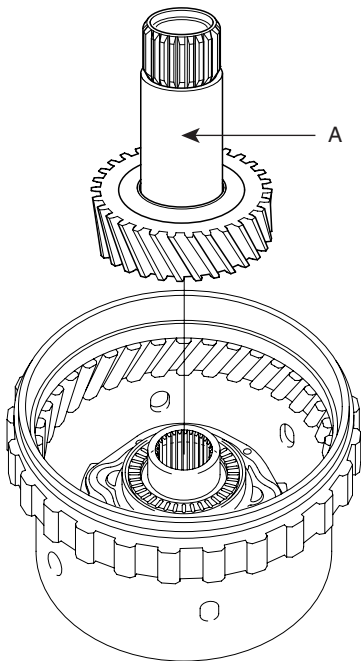

KKCF016G

8. Take out the snap ring(A) from the back side of the low & reverse annulus gear(B).

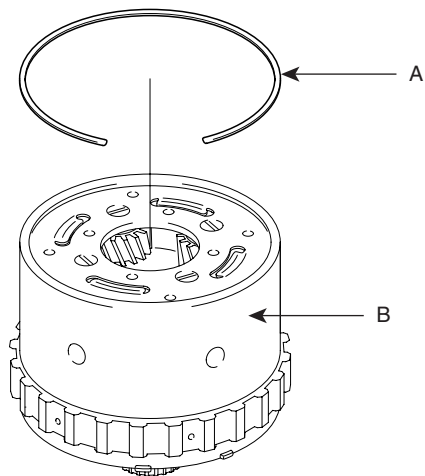

KKCF016I

**AT -50**

**AUTOMATIC TRANSAXLE (A5HF1)**

9. Remove the overdrive planetary carrier assembly(A).

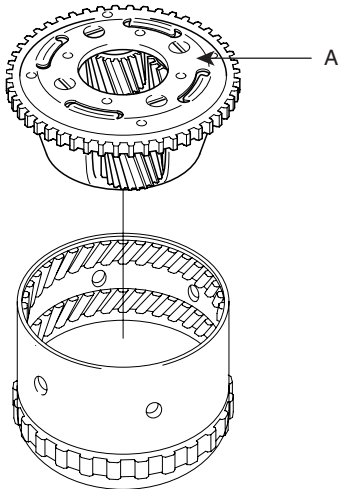

KKCF016J

3. Install the thrust bearing and the output planetary carrier assembly(A).

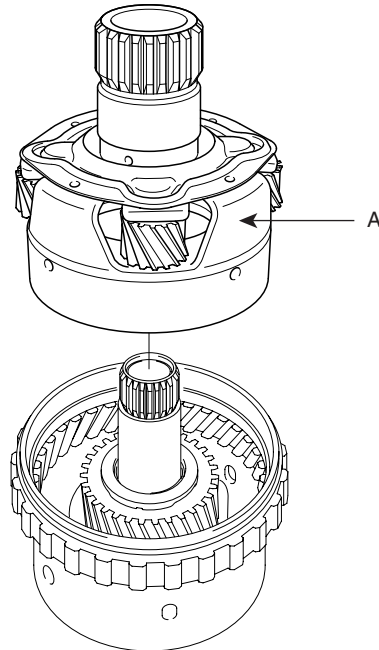

KKCF016E

**REASSEMBLY** EF7FE92C

1. After inserting the snap ring to the back side of the low & reverse planetary gear assembly, install the overdrive planetary carrier assembly.

2. Install the thrust bearing and the underdrive sun gear(A).

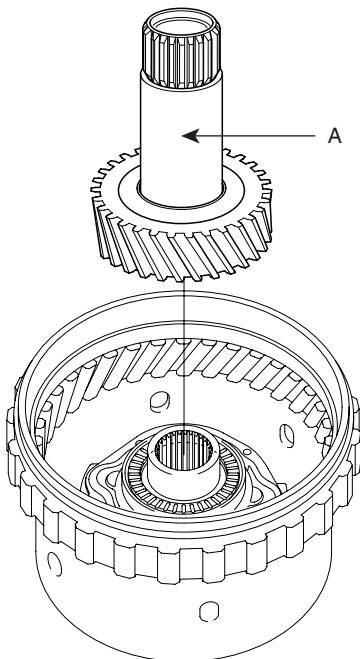

KKCF016G

4. Insert the snap ring(A).

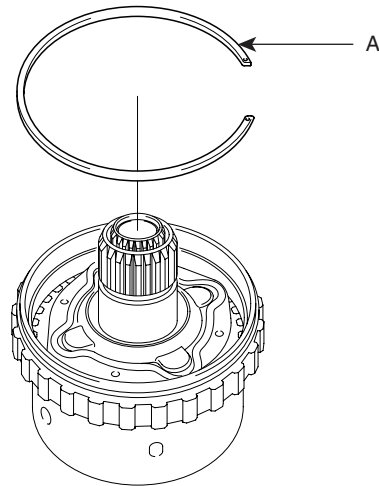

KKCF016D



**NOTE**

Pay attention to the direction of the thrust bearing when installing it.

5. Apply ATF on the inner/outer surface of the one way clutch(A) end bearing and assemble the bearing with the arrow mark on the inner race facing to rear.

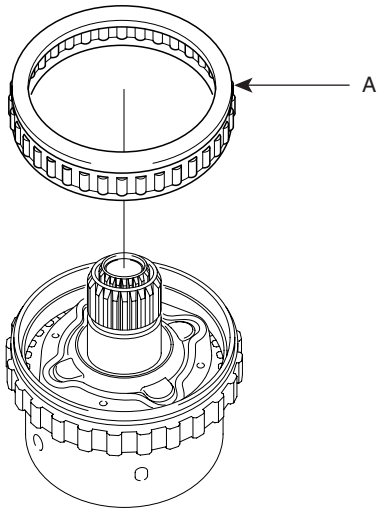

KKCF016C

6. Install the stopper plate(A).

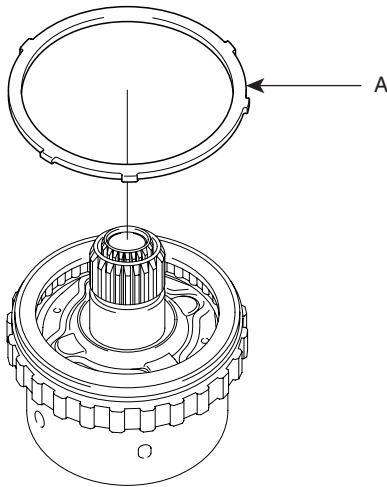

KKCF016B

**DIFFERENTIAL**

**COMPONENTS** EF5427C7

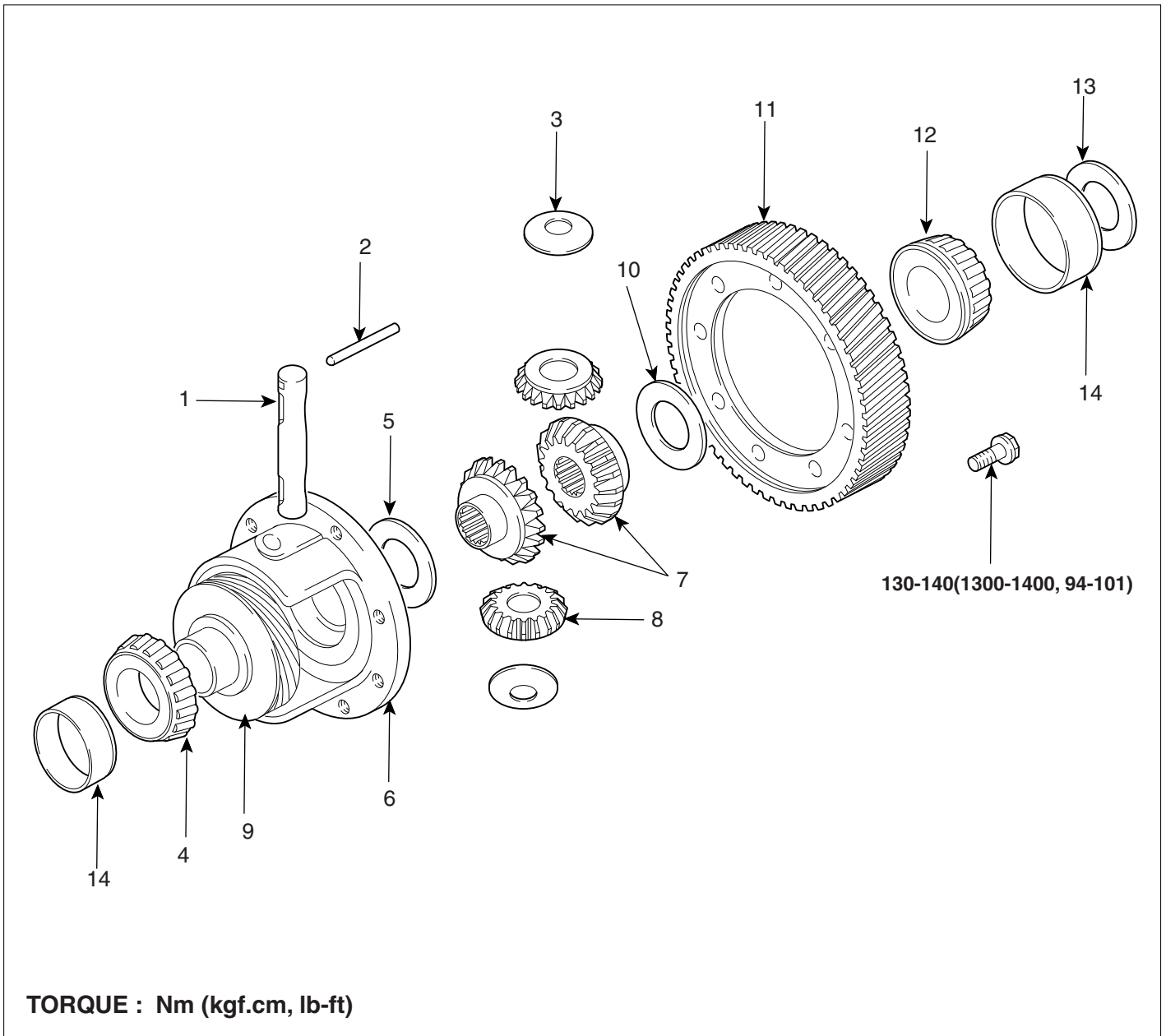

- |                         |                             |
|-------------------------|-----------------------------|
| 1. Pinion shaft         | 8. Pinion gear              |
| 2. Lock pin             | 9. Speedometer drive gear   |
| 3. Washer               | 10. Spacer                  |
| 4. Taper roller bearing | 11. Differential drive gear |
| 5. Spacer               | 12. Taper roller bearing    |
| 6. Differential case    | 13. Spacer                  |
| 7. Side gear            | 14. Outer race              |

EKRF510A

### DISASSEMBLY EEFA25D1

1. Clamp the differential case in a vise.
2. Remove the differential drive retaining bolts(A) and remove the differential drive gear(B) from the case(C).

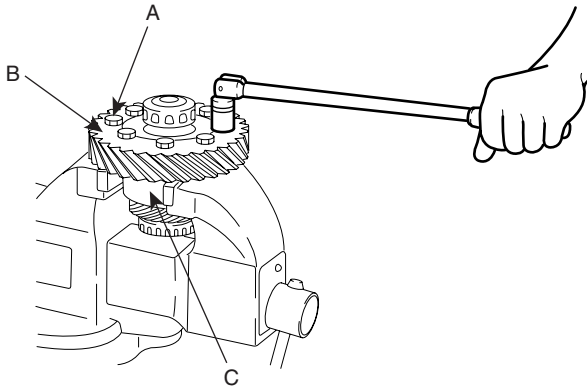

EKRF511D

3. Remove the taper bearing(A) using the sst(09457-22000).

#### CAUTION

**Do not reuse the bearing removed from the shaft.**

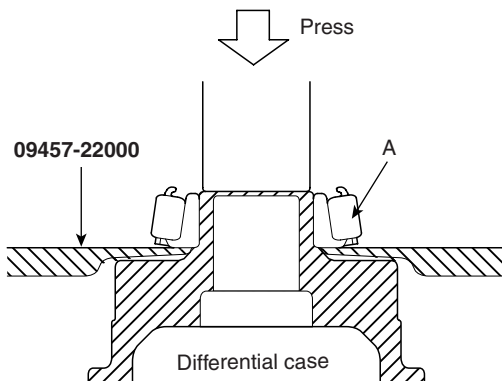

EKRF511A

4. Drive out the lock pin(B) from the hole A using a punch.

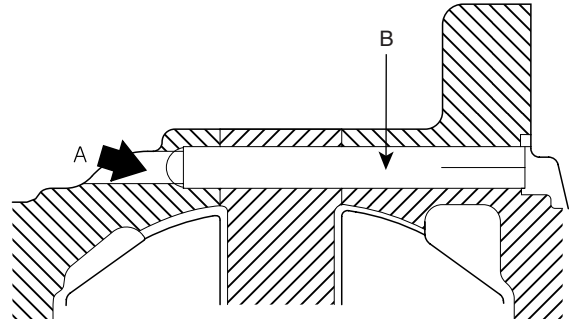

EKRF511B

5. Drive out the pinion shaft.
6. Remove the pinion gear, washers, side gear and spacers.

### REASSEMBLY ECDEAC5A

1. Install the spacer on the back of the side gear and then install the pinion gear(A) in the differential case.

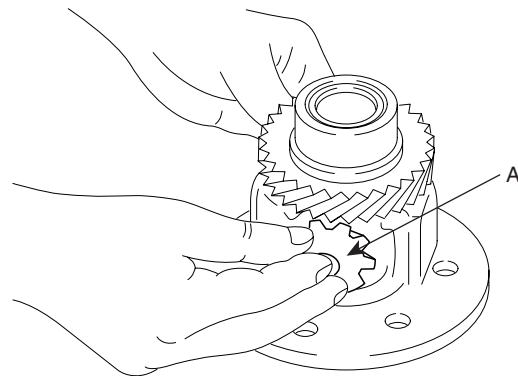

EKRF511E

#### CAUTION

- When installing a new side gear, use a spacer of medium thickness [0.83-0.92 mm (0.33-0.036 in.)].
- Do not reuse the lock pin.
- The lock pin head must be sunk below the flange surface of the differential case.

2. Set the washer on the back of each pinion and insert the two pinions to specified position while engaging them with the side gears(B) by turning them.

3. Insert the pinion shaft(A).

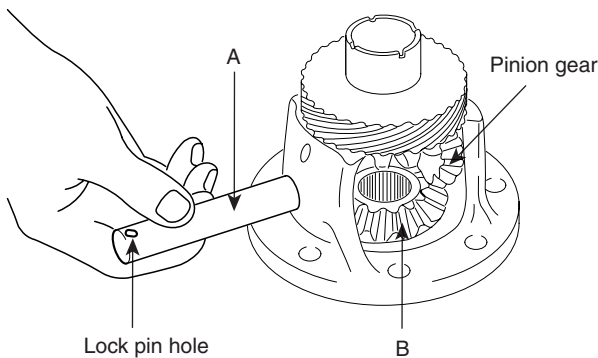

EKRF511C

4. Measure the backlash between the side gears and pinions.

Standard value :  
0.025-0.0150 mm (0.00095-0.0057 in.)

5. If the backlash is out of specification, disassemble and install the correct spacer, reassemble and remeasure.

**CAUTION**

**Adjust the backlash of both side gears to the same specification.**

6. Align the pinion shaft(C) lock pin hole with the case lock pin hole and insert the lock pin(B).

**CAUTION**

- Do not reuse the lock pin.
- The lock pin head must not protrude more than 3 mm (0.0118 in.).

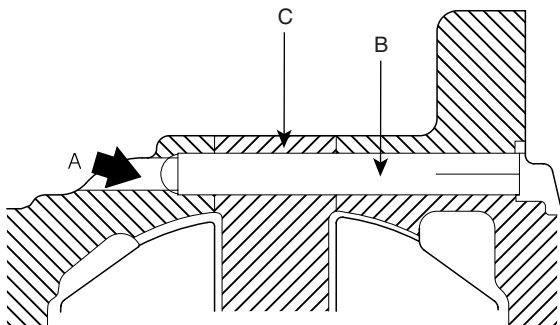

EKRF511G

7. Install the tapered roller bearing on both sides of the differential case using the special tool (09455-21100).

**CAUTION**

**When press-fitting the bearing, press on the inner race only.**

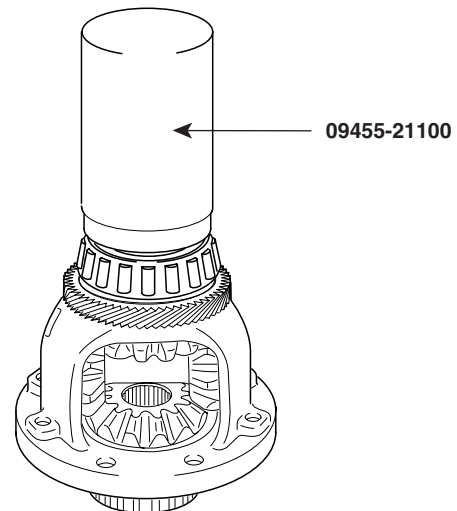

EKRF511F

8. Apply specified sealant to the entire threads of the bolts. Tighten to specifications using the sequence shown in the illustration. Specified sealant : BM stud locking No.2471

**CAUTION**

**If a bolt is reused, remove the old sealant from the threads.**

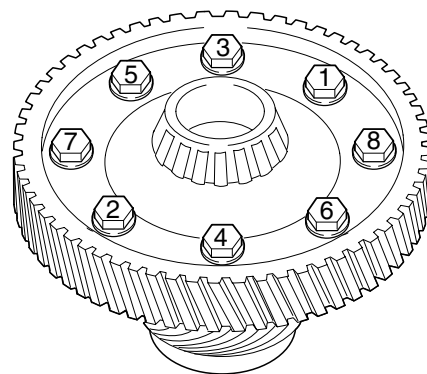

AMJF016J

**VALVE BODY**

**COMPONENTS(1)** EA26A36E

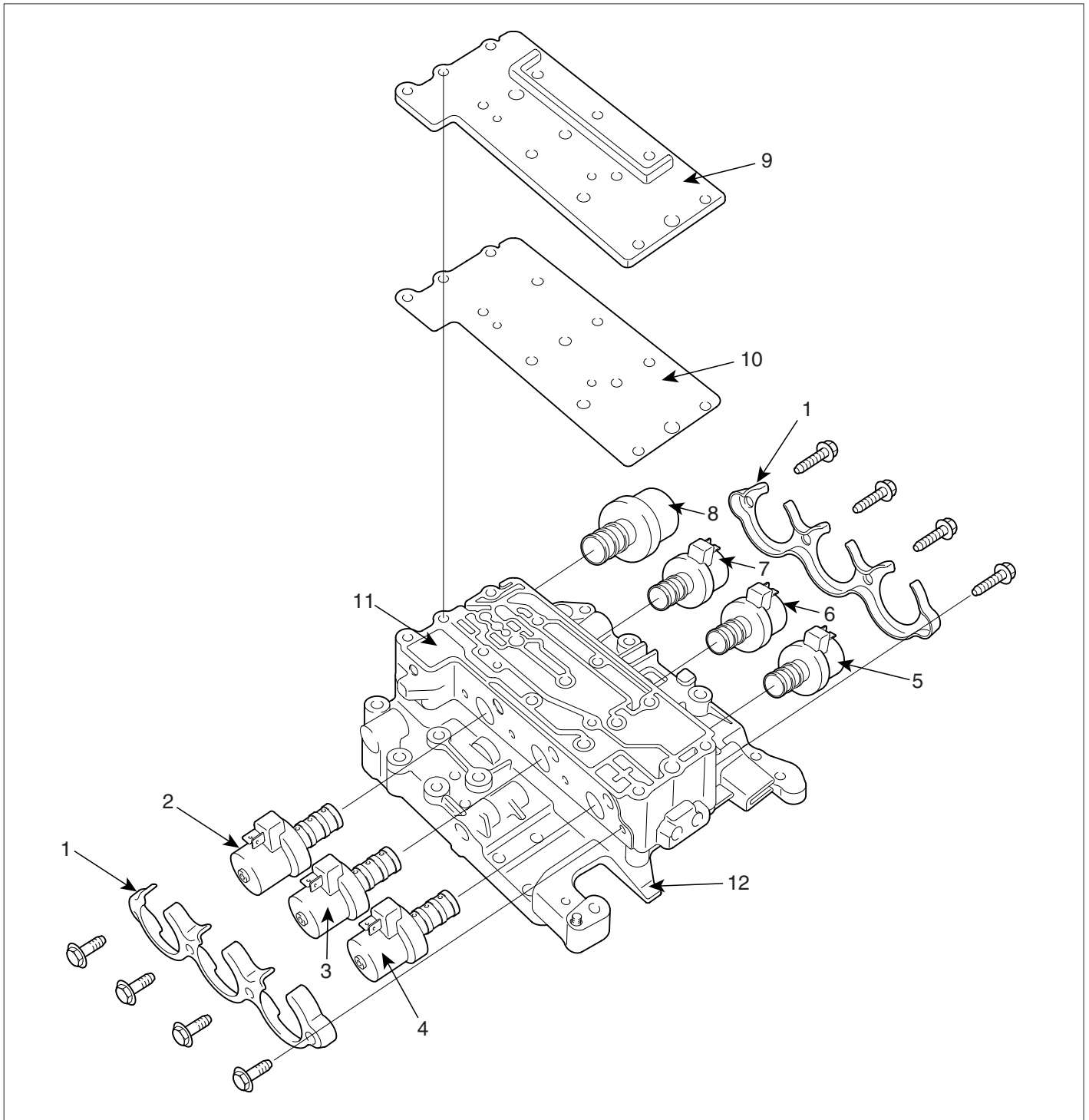

- |                            |                                  |
|----------------------------|----------------------------------|
| 1. Solenoid support        | 7. Solenoid valve (RED)          |
| 2. Solenoid valve (DCC)    | 8. VFS (Variable Force Solenoid) |
| 3. Solenoid valve (2nd)    | 9. Cover                         |
| 4. Solenoid valve (UD)     | 10. Cover seperating plate       |
| 5. Solenoid valve (OD)     | 11. Outside valve body           |
| 6. Solenoid valve (LR/DIR) | 12. Inside valve body            |

COMPONENTS(2)

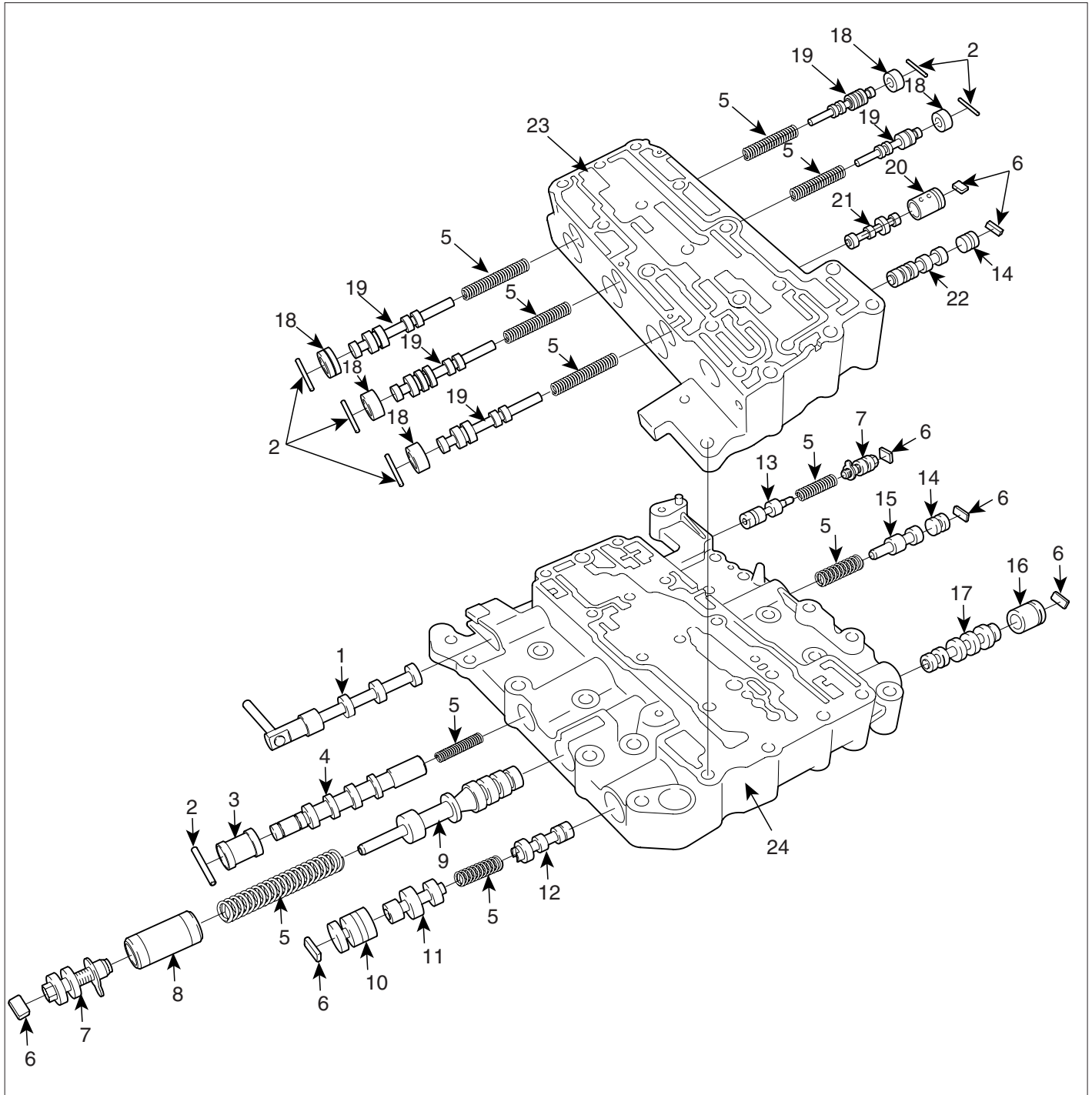

- 1. Manual valve assembly
- 2. Roller
- 3. Damper clutch control sleeve
- 4. Damper clutch control valve
- 5. Coil spring
- 6. Stopper plate
- 7. Adjust screw assembly
- 8. Regulator valve sleeve

- 9. Regulator valve
- 10. Fail safe sleeve A
- 11. Fail safe valve A2
- 12. Fail safe valve A1
- 13. Reducing valve
- 14. Stopper plug
- 15. T/C press control valve
- 16. Fail safe sleeve B

- 17. Fail safe valve B
- 18. Press control sleeve
- 19. Press control valve
- 20. Fail safe sleeve C
- 21. Fail safe valve C
- 22. Switch valve
- 23. Outside valve body
- 24. Inside valve body

**DISASSEMBLY**    EEBACB47

1. Remove the solenoid support(A).

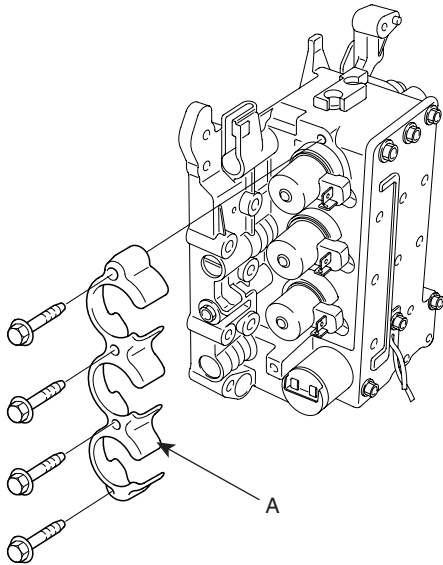

KKCF009B

2. Remove the solenoid valve(A).

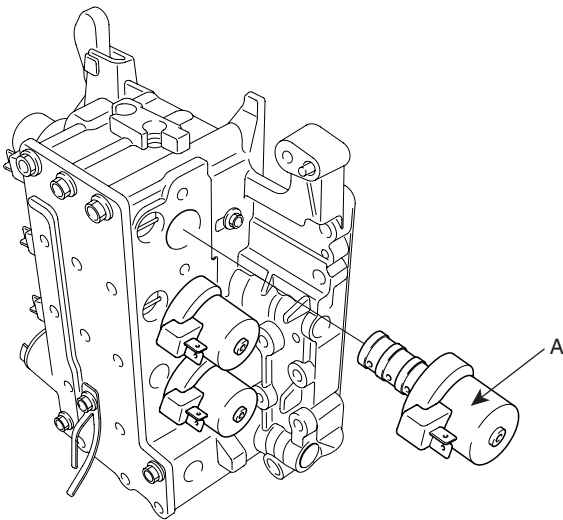

KKCF009C

3. Remove the VFS(Variable Forced Solenoid)(A).

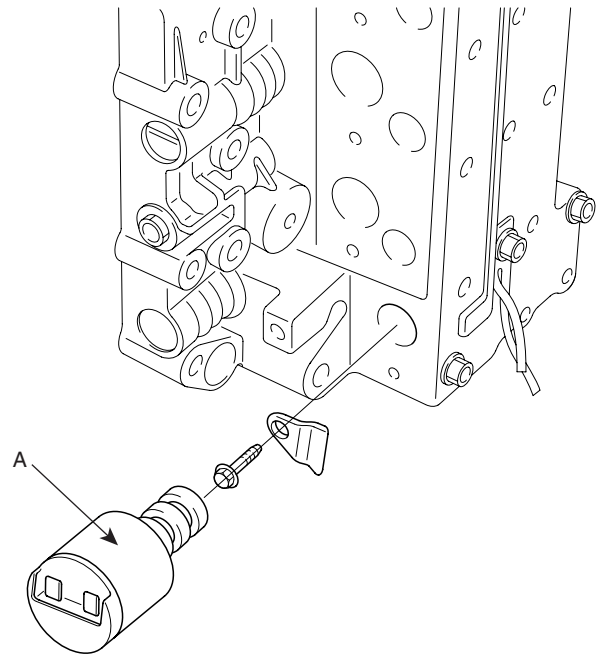

KKCF009D

4. Remove the manual valve(A).

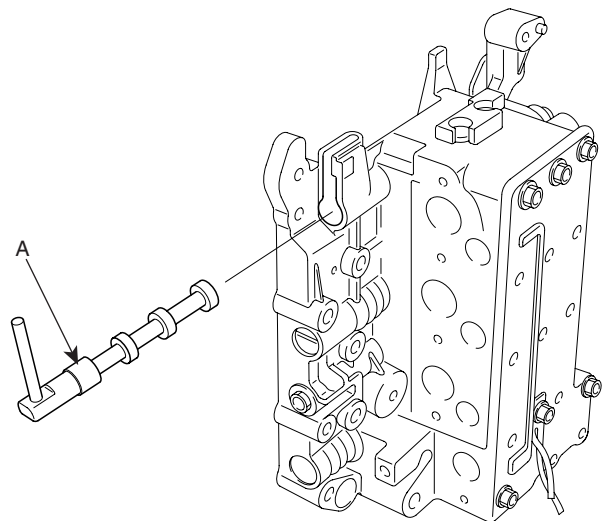

KKCF009E

**AT -58**

**AUTOMATIC TRANSAXLE (A5HF1)**

5. Loosening the bolts and remove the cover(A) and the cover seperating plate(B).

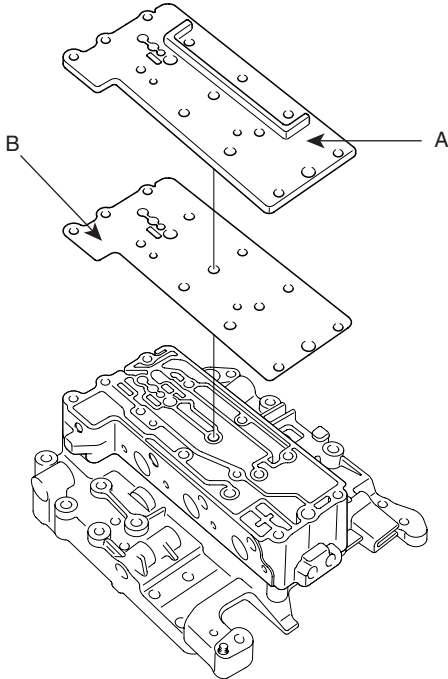

KKCF009F

7. Take out the steel balls(B) and UD/ OD clutch coil springs(A)(2EA) from the inside valve body(C).

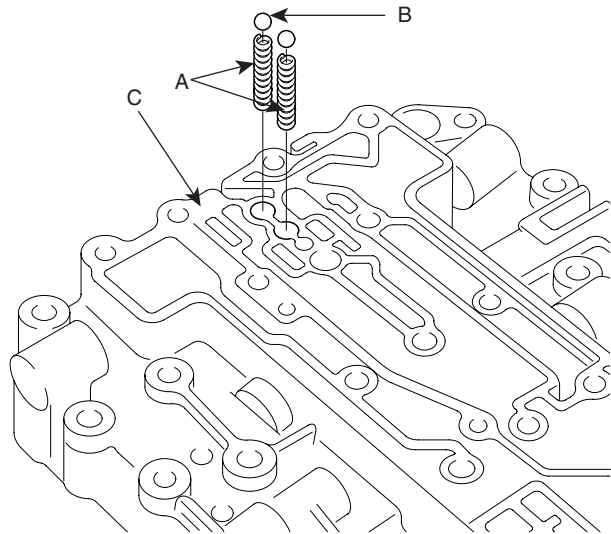

KKCF009H

6. Remove the outside valve body(A) and the outside seperating plate(B).

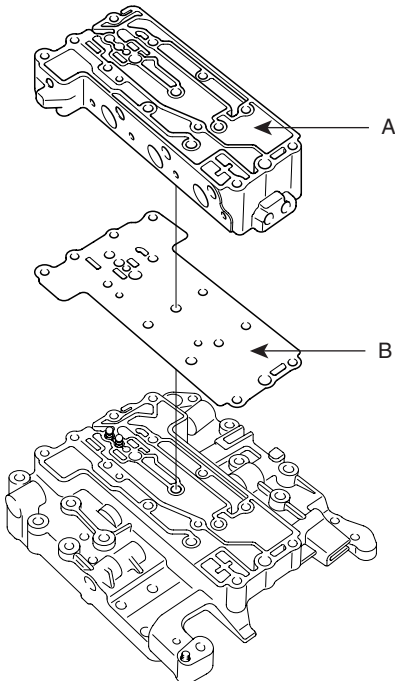

KKCF009G

8. Loosening the bolts(A), remove the inside seperating plate(B).

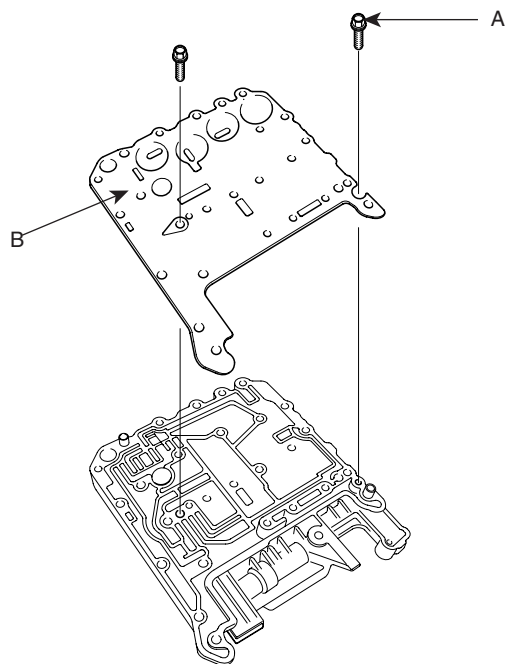

KKCF009I

**AUTOMATIC TRANSAXLE SYSTEM**

9. Remove the damping valve(A) and coil spring(B) from the inside valve body(C).

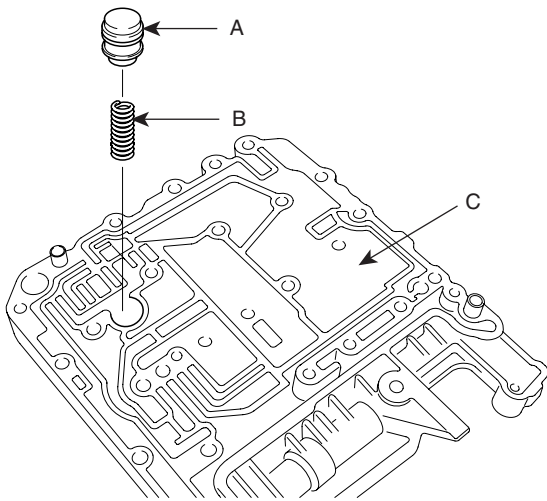

KKCF009J

10. Remove the underdrive/overdrive steel ball, coil spring, reverse clutch steel ball and coil spring.

11. After taking out the roller(A), remove the damper clutch control sleeve(B), valve(C) and coil spring(D).

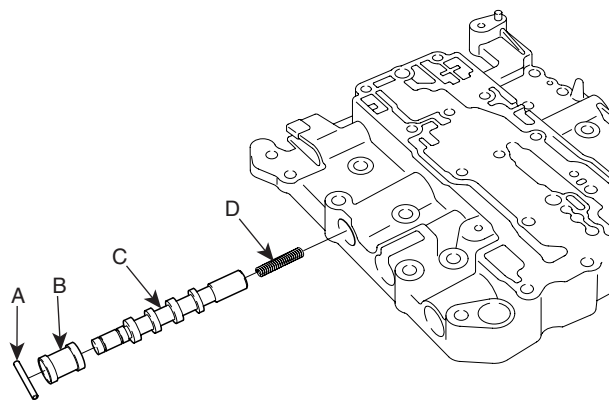

KKCF009K

12. After pulling out the stopper plate(A), remove the adjusting screw(B), regulator valve sleeve(C), coil spring(D) and regulator valve(E) in this order.

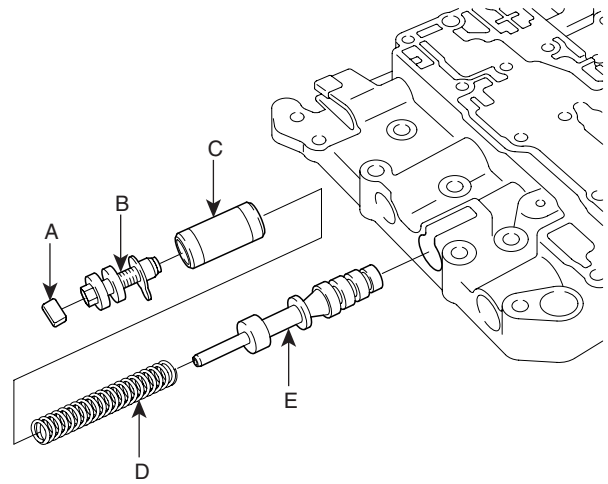

KKCF009L

13. After drawing out the stopper plate(A), remove the fail safe sleeve A(B), fail safe valve A2(C), coil spring(D) and fail safe valve A1(E) in this order.

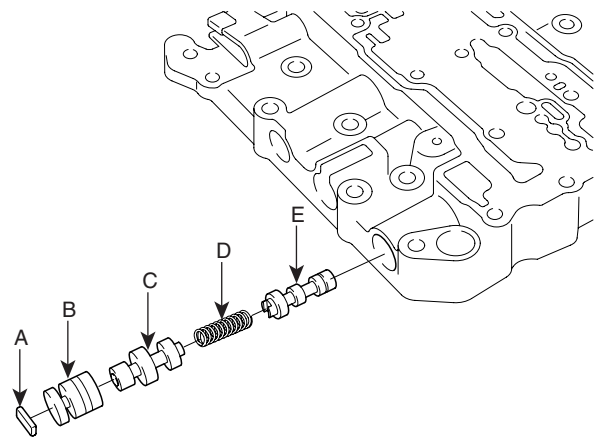

KKCF009M

## AT -60

## AUTOMATIC TRANSAXLE (A5HF1)

14. After picking out the stopper plate(A), remove the adjusting screw(B), coil spring(C) and reducing valve(D) in this order.

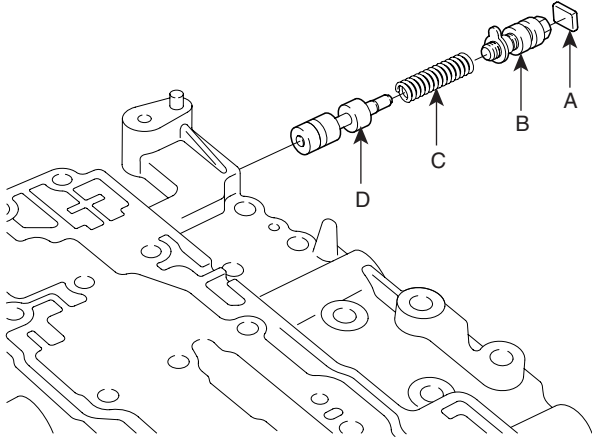

KKCF009N

15. After picking out the stopper plate(A), remove the stopper plug(B), torque converter control valve(C) and spring(D) in this order.

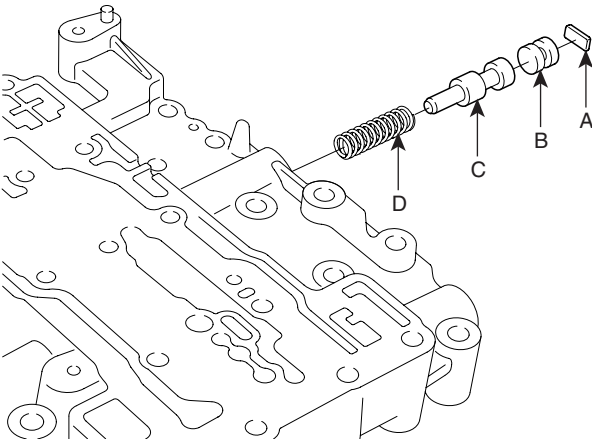

KKCF009O

16. After taking the stopper plate(A), separate the fail safe sleeve (B) and the fail safe valve (C) in order.

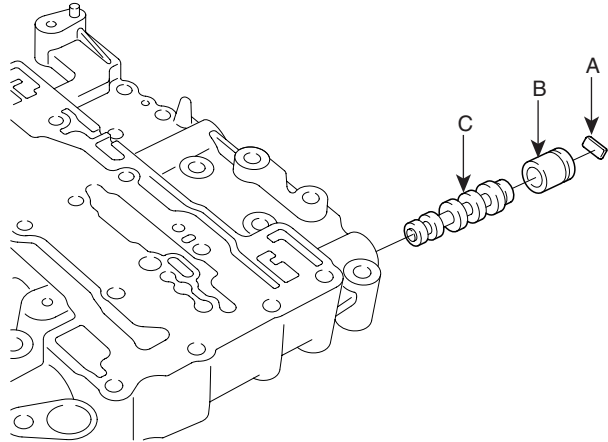

KKCF009P

17. After taking the roller(A), separate the over drive pressure control sleeve(B), pressure control valve(C) and coil spring(D).

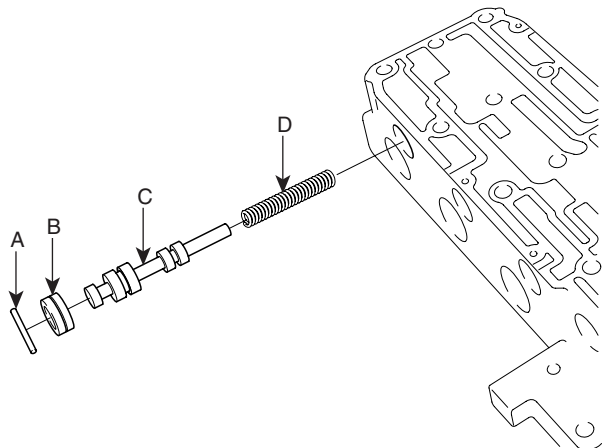

KKCF009Q

18. After taking the roller(A), separate the LR/direct pressure control sleeve(B), pressure control valve(C) and coil spring(D).

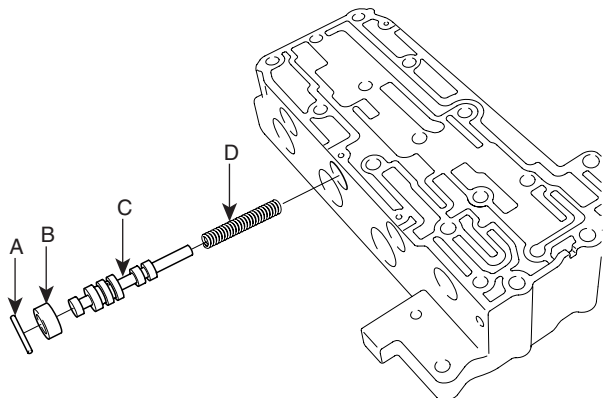

KKCF009R

**AUTOMATIC TRANSAXLE SYSTEM**

19. After taking the roller(A), separate the reduction pressure control sleeve(B), pressure control valve(C) and coil spring(D).

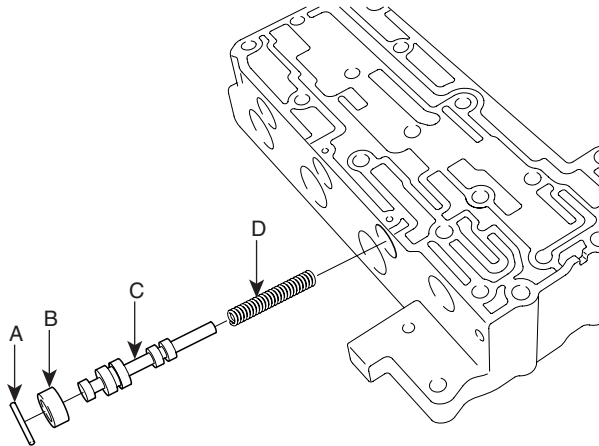

KKCF009S

21. After taking the roller(A), separate the 2nd pressure control sleeve(B), pressure control valve(C) and coil spring(D).

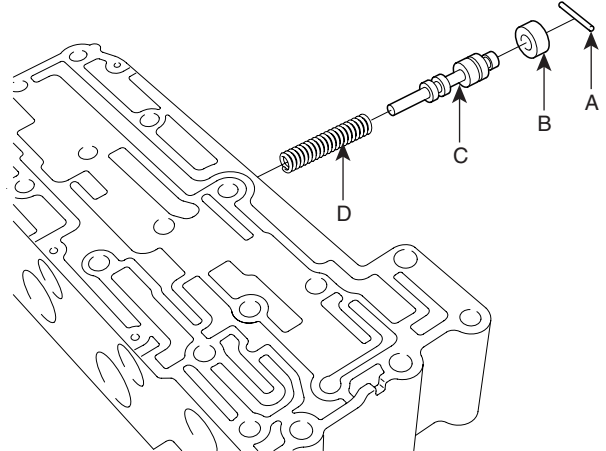

KKCF009U

20. After taking the roller(A), separate the underdrive pressure control sleeve(B), pressure control valve(C) and coil spring(D).

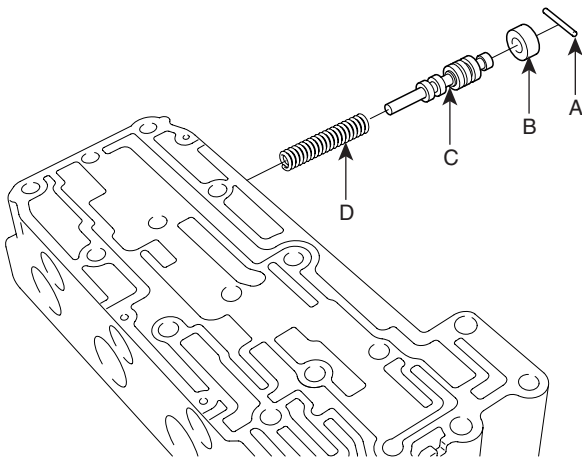

KKCF009T

22. After taking out the stopper plate(A), separate the fail safe sleeve C(B) and fail safe valve C(C) in order.

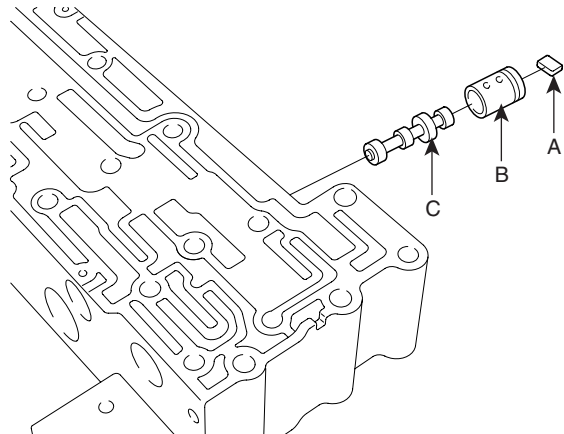

KKCF009V

23. After taking the stopper plate(A), separate the stopper plug(B) and switch valve(C) in order.

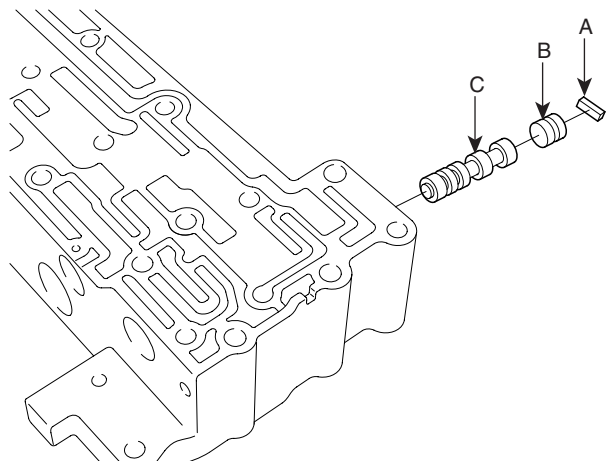

KKCF009W

**REASSEMBLY** E246DFCD

1. Assemble the valves to the valve body with the springs and sleeves etc. Observe the caution below.

**CAUTION**

- *When assembling the regulator valve sleeve, turn the sparkling segment(A) as follows to face the valve body side.*



KKCF009X

- *When assembling the damper clutch control sleeve, turn the thick identification band segment(B) as follows to face the valve body side.*

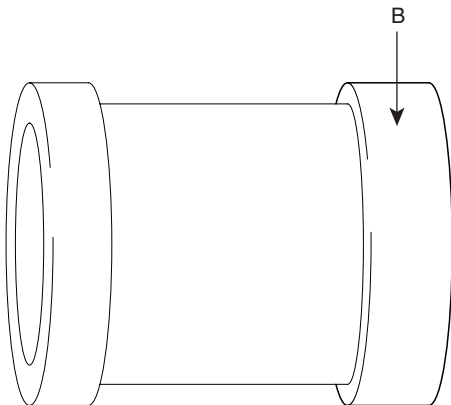

KKCF009Y

- *Observe at assembly of the damping valve coil spring(A), coil spring(B) and reverse clutch coil spring(C) because size differs each.*

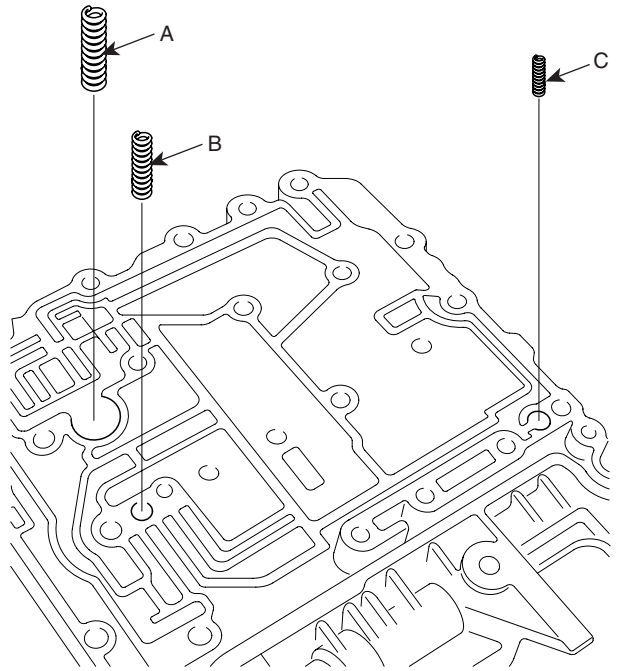

KKCF009Z

2. Install the inside separation plate(B) by the bolts(A).

**TORQUE:**

4.9~6.9Nm(50~70 Kgf.cm, 3.6~5.1 lb-ft)

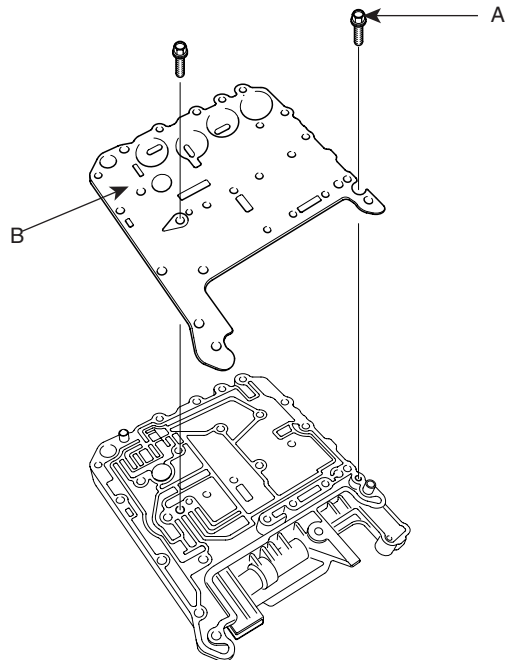

KKCF009I

3. After inserting the steel balls and coil springs(each 2EA) in the inside valve body, install the outside valve body and separation plate.
4. Install the cover separation plate and cover. Tighten the bolts.

---

**TORQUE:**

9.8~11.8Nm(100~120 Kgf.cm, 7.2~8.7 lb-ft)

---

5. After installing the manual valve, VFS, and each solenoid controlled valve, fit the solenoid support.



**NOTE**

*Spread ATF or white vaseline on O- ring and assemble lest should be damaged.*

**UNDERDRIVE CLUTCH**

**COMPONENTS** EEB7EBD9

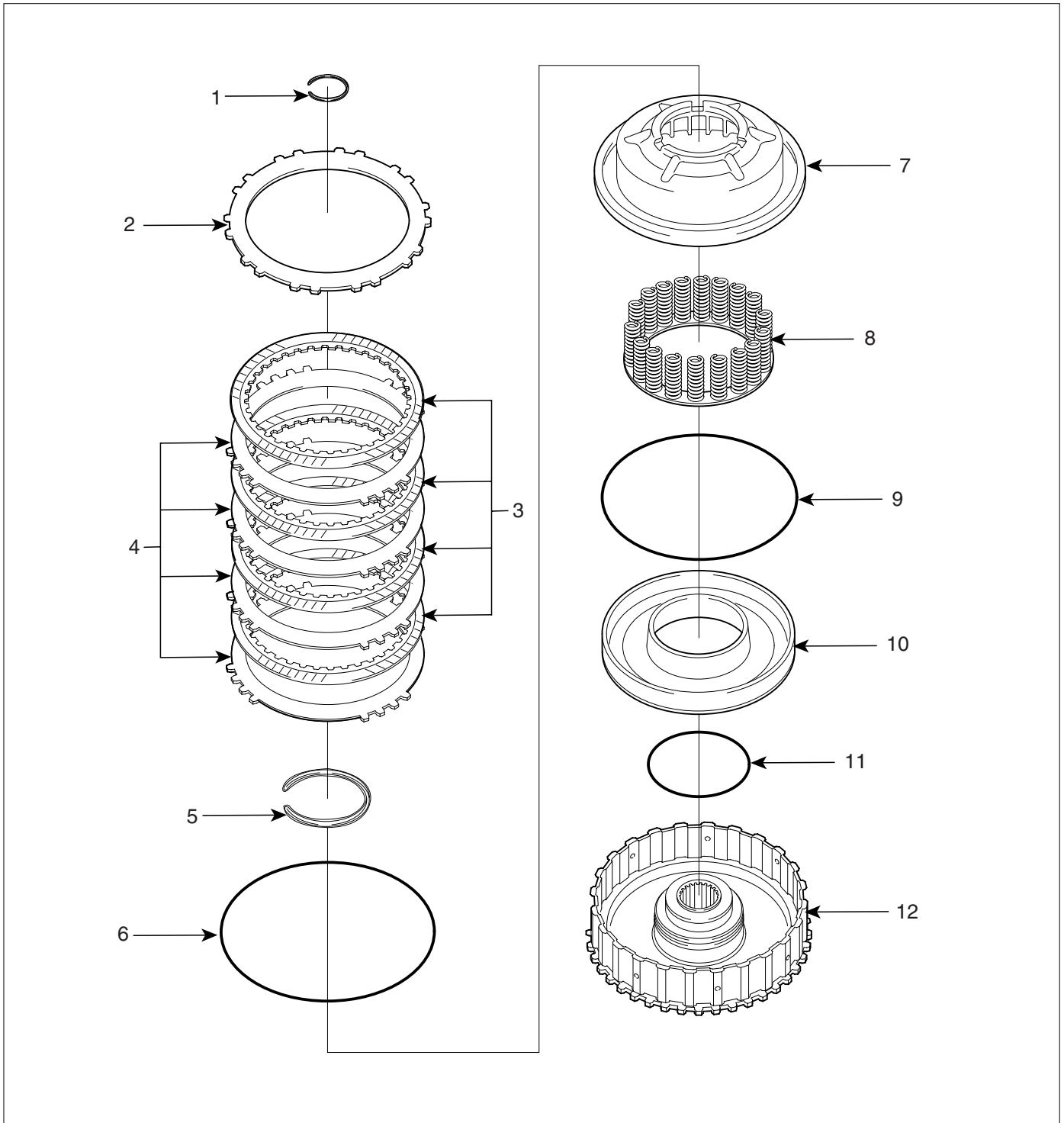

- 1. Snap ring
- 2. Clutch reaction plate
- 3. Clutch discs
- 4. Clutch plates
- 5. Snap ring
- 6. D-ring

- 7. Underdrive clutch spring retainer
- 8. Return spring
- 9. D-ring
- 10. Underdrive clutch piston
- 11. D-ring
- 12. Underdrive clutch retainer

**DISASSEMBLY** EC31C927

1. Take out the input shaft snap ring(A).

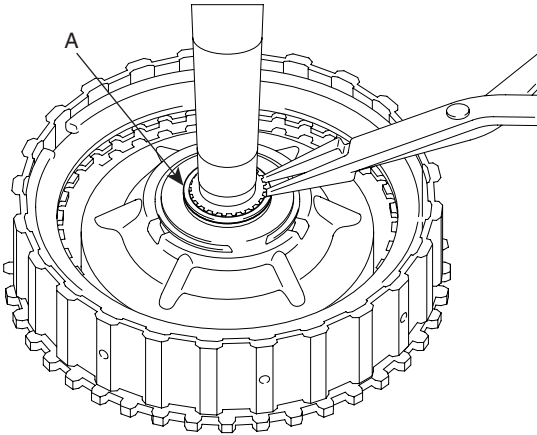

KKCF010B

2. After removing the input shaft(A), take two seal rings(B).

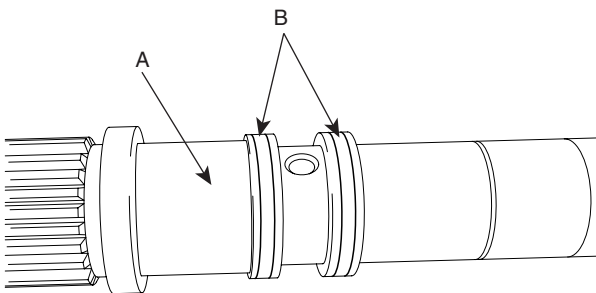

KKCF010C

3. After removing the clutch reaction plate snap ring, take the plate(A).

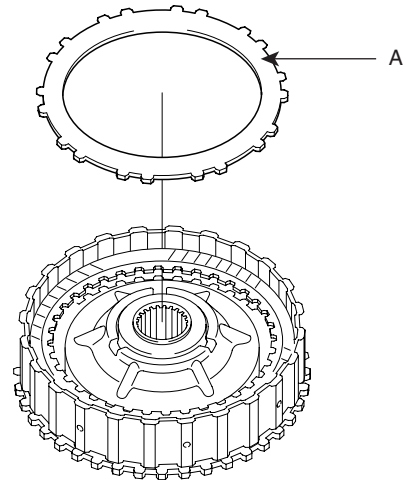

KKCF010D

4. Separate the clutch discs(4EA)(A) and the plates(4EA)(B).

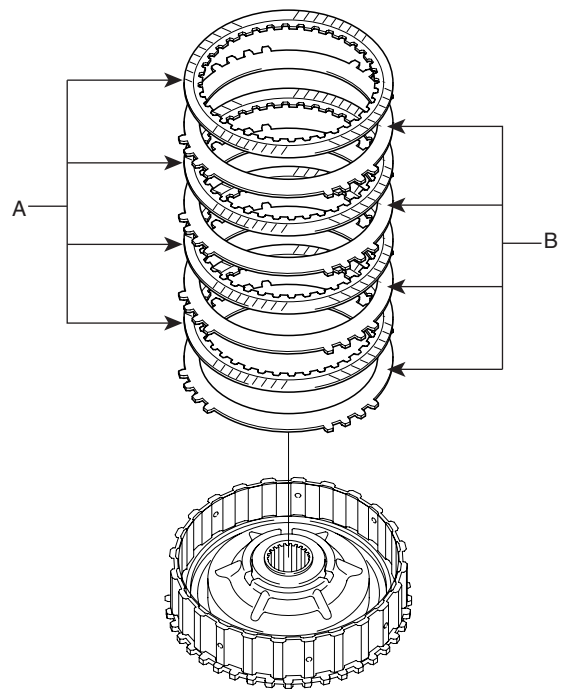

KKCF010E

5. After pushing the underdrive clutch spring retainer with the SST(09453-24000) and a press machine, take the snap ring.

**AT -66**

**AUTOMATIC TRANSAXLE (A5HF1)**

6. Remove the clutch spring retainer(A) with the D-ring.

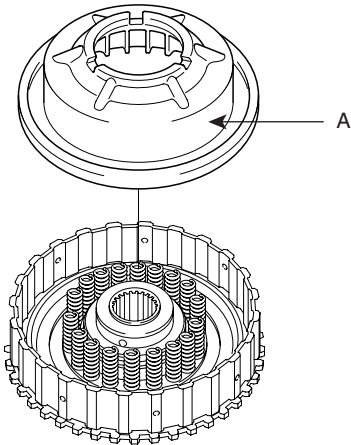

KKCF010F

8. Remove the underdrive clutch piston(A) by using compressed air.

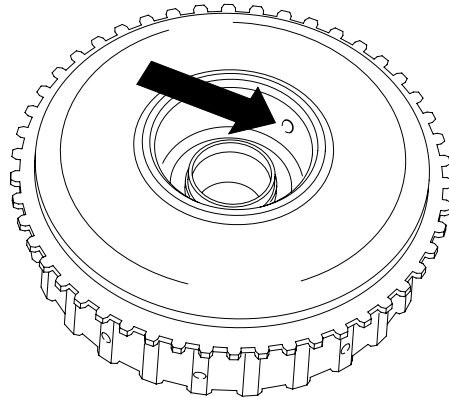

KKCF010H

7. Remove the clutch return spring(A).

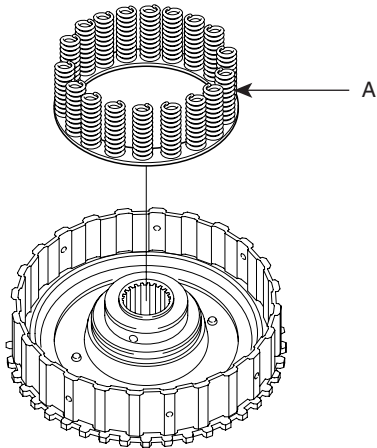

KKCF010G

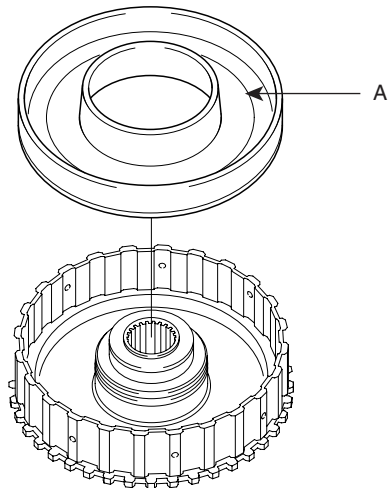

KKCF010I

9. Remove the D-rings(2EA).

**REASSEMBLY** EEACD9AB

1. Install the D-rings(2EA).
2. Install the underdrive clutch piston(A).

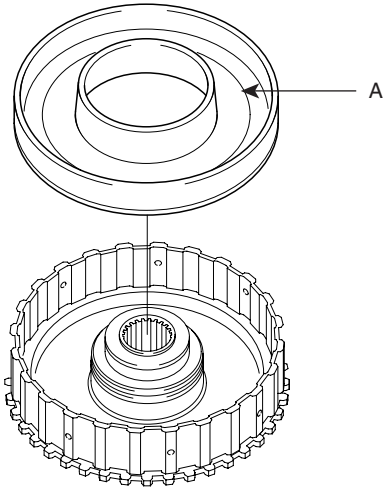

KKCF010I

3. Install the clutch return spring(A).

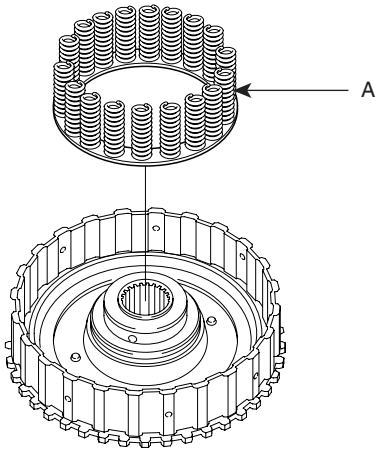

KKCF010G

4. Install the clutch spring retainer(A) with the D-ring.

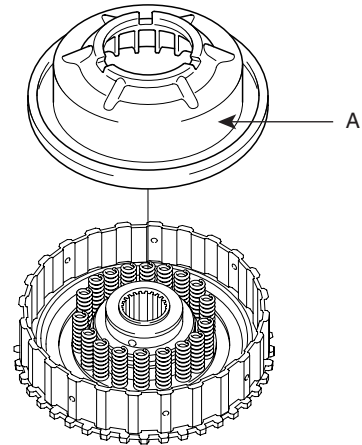

KKCF010F

5. After pushing the underdrive clutch spring retainer with the SST(09453-24000) and a press machine, fix the snap ring.
6. Align the teeth(A) of the clutch plate, clutch disc and clutch reaction plate with the hole(B) of the underdrive clutch as shown below.

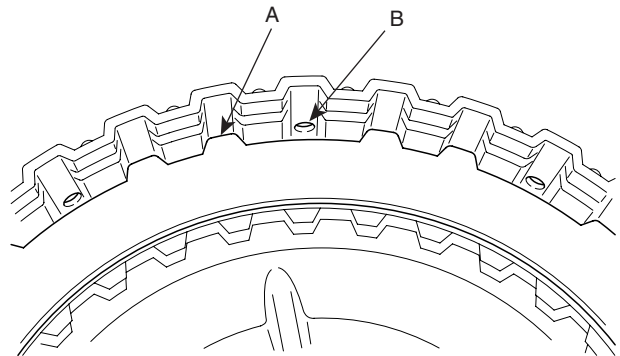

KKCF010J

**! CAUTION**

- Dip the clutch discs(A) in ATF sufficiently before assembly.
- Insert the clutch reaction plate(B) to the direction such as the picture below.

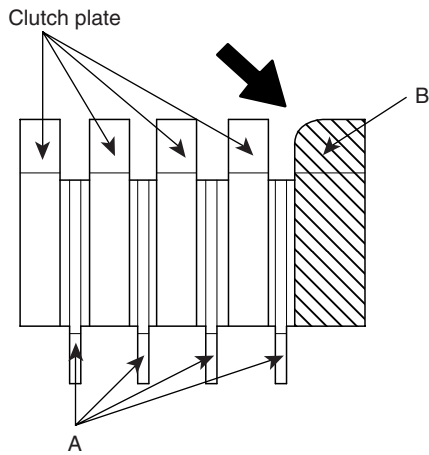

EKRF505B

10. Make the input shaft pass through the underdrive clutch assembly and fix it with a snap ring(A).

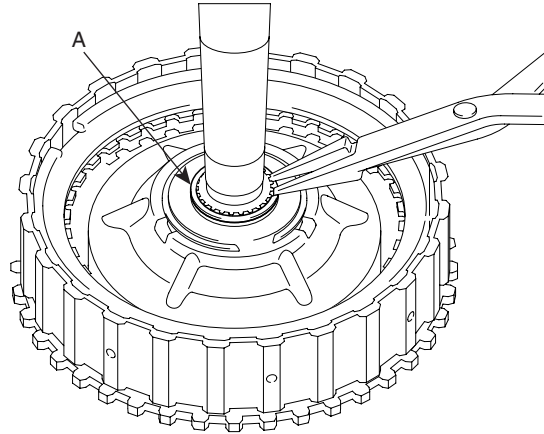

KKCF010B

7. Install the snap ring.
8. Check the end play between the snap ring and the reaction plate with  $1500 \pm 50\text{N}$  ( $150 \pm 5\text{Kgf}$ ,  $337.2 \pm 11.2\text{lb}$ ) weight and  $350 \pm 25\text{kPa}$  ( $3.5 \pm 0.25\text{kgf/cm}^2$ ,  $50.76 \pm 3.62\text{psi}$ ) air pressure applied.

---

End play: 1.6 ~ 1.8mm(0.0630~0.0709 inch)

---

9. If the end play deviates from the standard value above, choose a proper snap ring from the table below.

Part No.	Thickness(mm/inch)
45427-39520	2.0 (0.0787)
45427-39521	2.1 (0.0827)
45427-39522	2.2 (0.0866)
45427-39523	2.3 (0.0906)
45427-39524	2.4 (0.0945)
45427-39525	2.5 (0.0984)
45427-39526	2.6 (0.1024)
45427-39527	2.7 (0.1063)
45427-39528	2.8 (0.1102)
45427-39529	2.9 (0.1142)
45427-39530	3.0 (1.1181)
45427-39519	1.9 (0.0748)
45427-39516	1.6 (0.0630)
45427-39517	1.7 (0.0669)
45427-39518	1.8 (0.0709)

REVERSE AND OVERDRIVE CLUTCH

COMPONENTS E5EF8E33

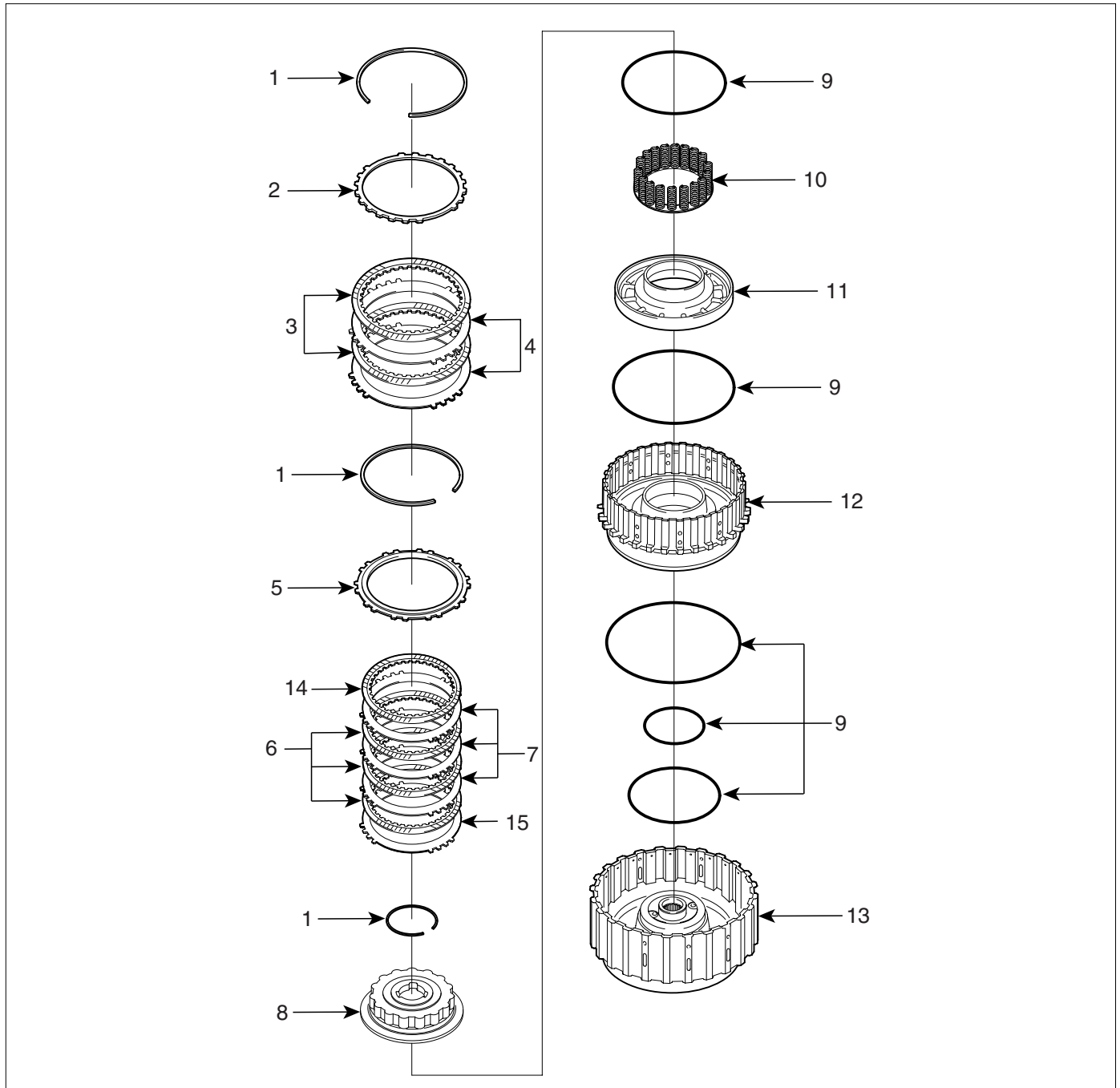

- |  |                                       |
|--|---------------------------------------|
| 1. Snap ring                                 | 9. D-ring                             |
| 2. Reverse clutch reaction plate             | 10. Clutch return spring              |
| 3. Reverse clutch discs                      | 11. Reverse clutch piston             |
| 4. Reverse clutch plates                     | 12. Overdrive clutch piston           |
| 5. Overdrive reaction plate                  | 13. Reverse clutch retainer           |
| 6. Overdrive clutch disc (Inner-single side) | 14. Double side overdrive clutch disc |
| 7. Overdrive clutch disc (outer-single side) | 15. Overdrive clutch plate            |
| 8. Overdrive clutch spring retainer          |                                       |

**AT -70**

**AUTOMATIC TRANSAXLE (A5HF1)**

**DISASSEMBLY** E6A4640E

1. Remove the reverse clutch reaction plate snap ring(A).

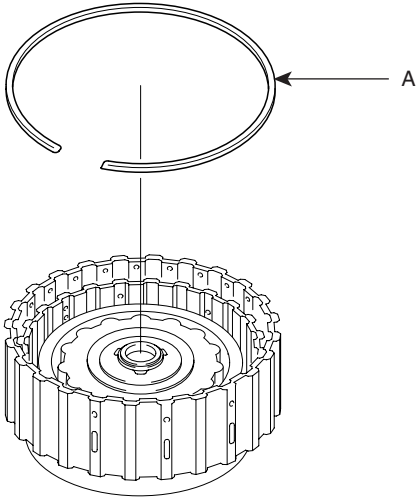

KKCF013B

2. Remove the reverse clutch reaction plate(A).

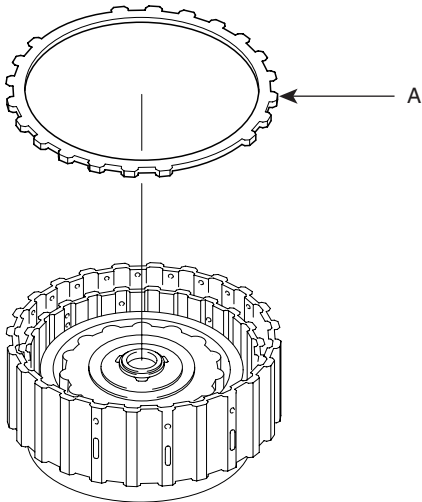

KKCF013C

3. Remove the reverse clutch discs(A-2EA) and plates(B-2EA).

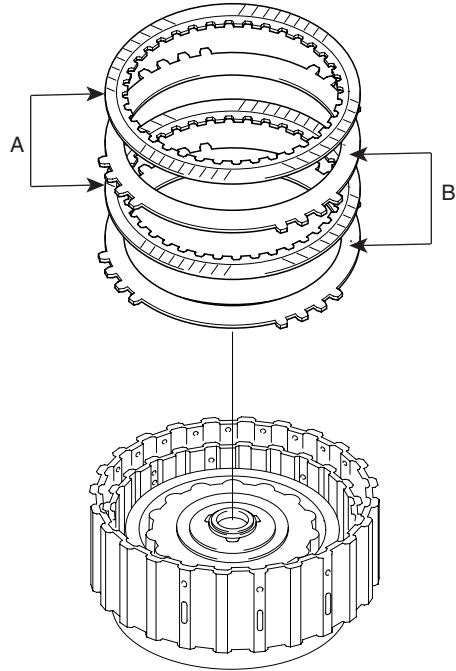

KKCF013D

4. Remove the overdrive clutch reaction plate snap ring(A).

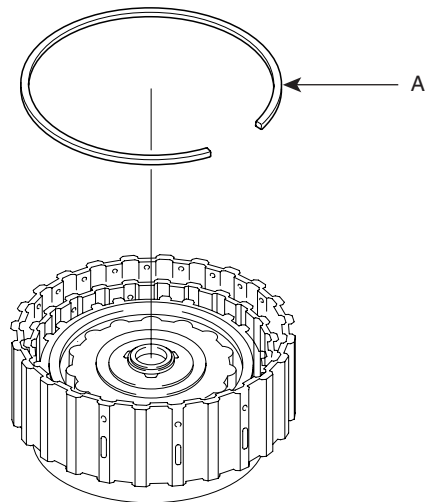

KKCF013E

5. Remove the overdrive clutch reaction plate(A).

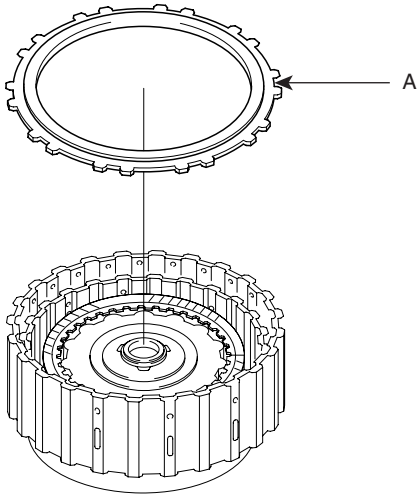

KKCF013F

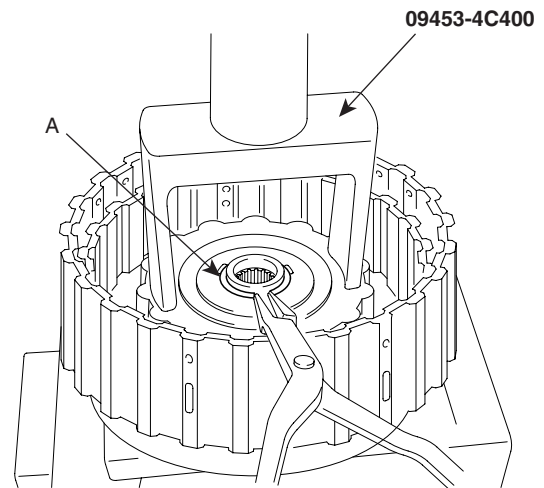

KKCF013H

6. Remove the overdrive clutch discs(A-4EA) and the plates(B-4EA).

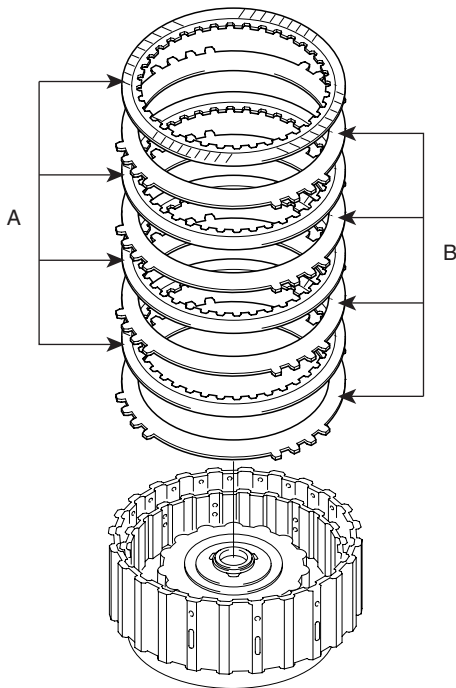

KKCF013G

7. Using the SST(09453-4C400), remove the clutch spring retainer snap ring(A).

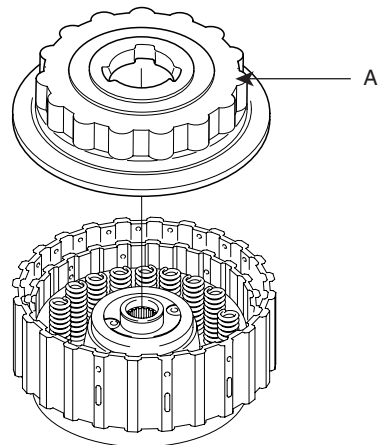

KKCF013I

9. Remove the clutch return spring(A).

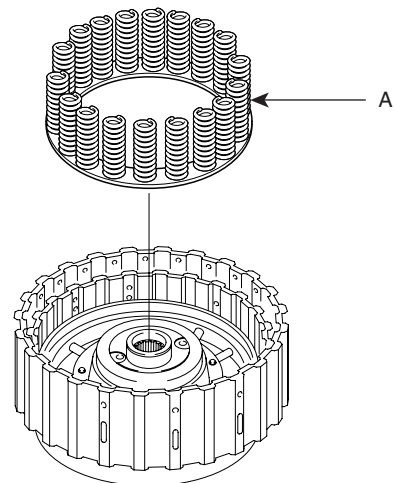

KKCF013J

**AT -72**

**AUTOMATIC TRANSAXLE (A5HF1)**

10. Remove the reverse and overdrive clutch piston(A) using compressed air. Separate the D-ring from the piston, then.

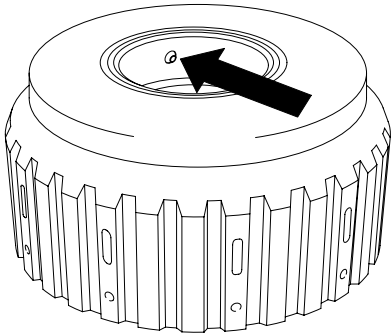

KKCF013K

11. Separate the reverse clutch piston(A) from the overdrive clutch piston(B) and take the D-rings out of the reverse clutch piston(A).

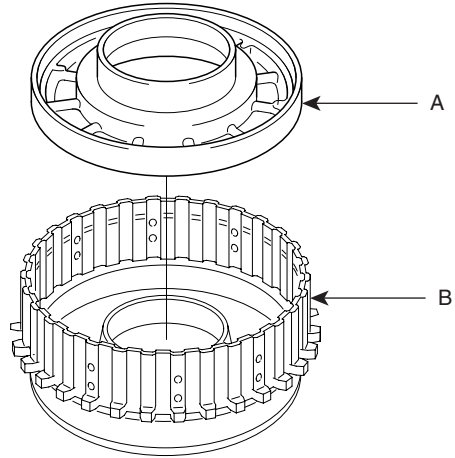

KKCF013M

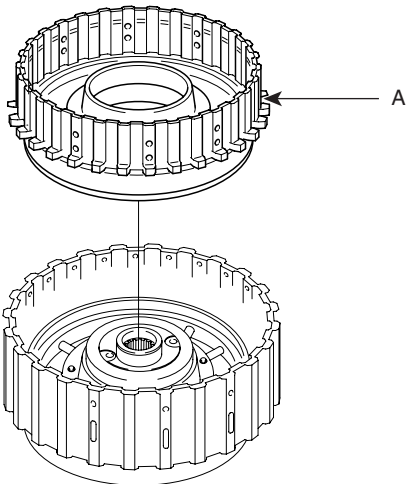

KKCF013L

12. Remove the D-rings(A-2EA) from the reverse clutch retainer(B).

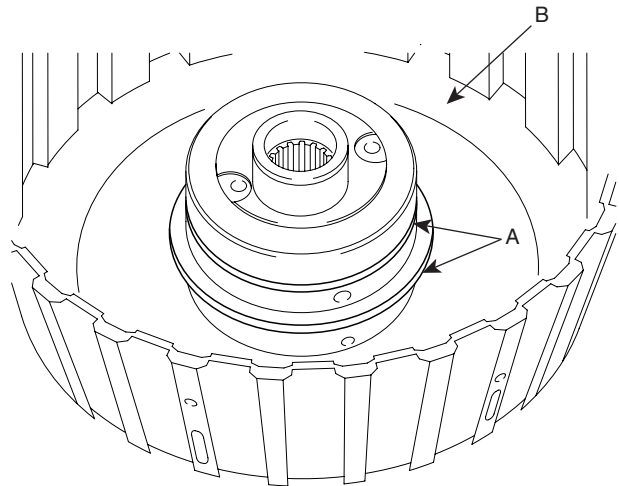

KKCF013N

**REASSEMBLY** EAFFDF0E

1. Attach each D- ring to reverse clutch retainer, reverse clutch piston, over drive clutch piston, over drive clutch spring retainer.
2. When attaching the overdrive clutch piston(A) to the reverse clutch retainer(B), align the position of holes(C) as follows.

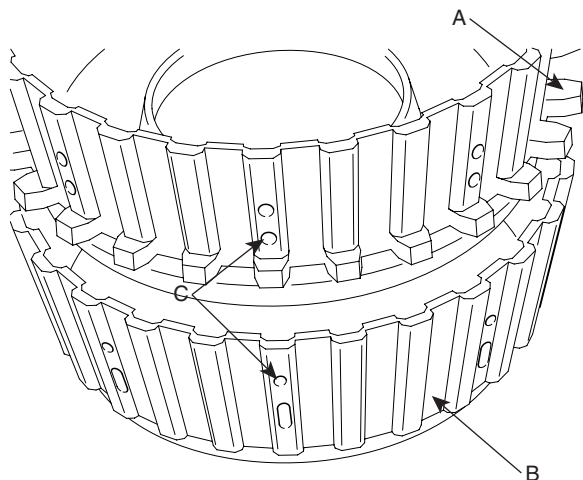

KKCF0130

3. Install the reverse clutch piston to the overdrive clutch piston.
4. After installing clutch return spring, attach over drive clutch spring retainer(A).

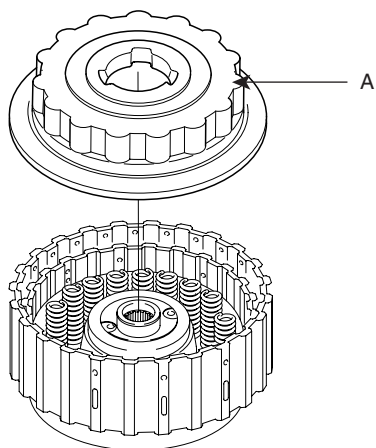

KKCF0131

5. Using the SST(09453-4C400), install the clutch spring retainer snap ring.

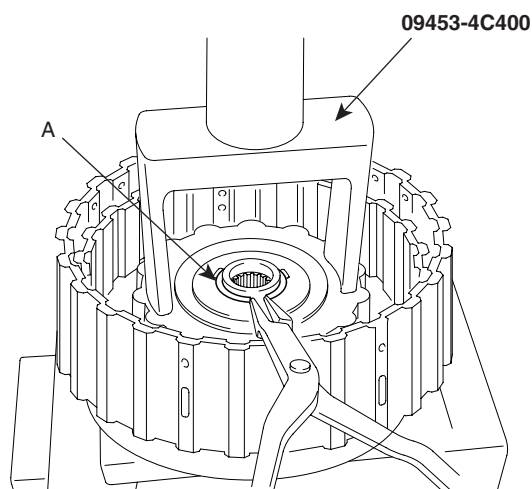

KKCF013H

6. Applying 49N(5kgf, 11lb) weight on the return spring retainer, measure the gap between the snap ring(A) and the retainer(B). If the gap deviates from the end play value below, select an appropriate snap ring from the table.

End play: 0T ~ 0.09L mm(0~0.0035inch)

Part No.	Type
45443-39148	Snap ring 1
45853-39153	Snap ring 2
45459-39158	Snap ring 3
45853-39163	Snap ring 4

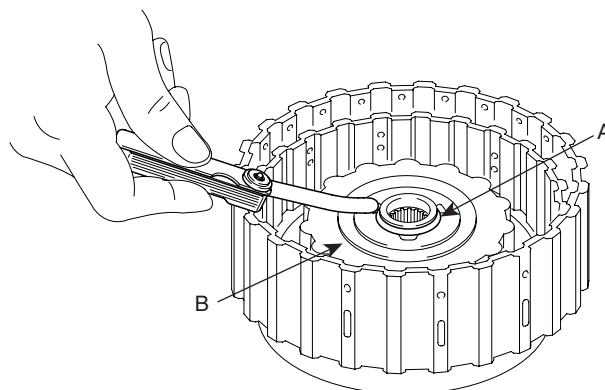

KKCF013P

**AT -74**

**AUTOMATIC TRANSAXLE (A5HF1)**

7. Aligning the teeth(A) of the overdrive clutch discs(4EA), plates(4EA) and clutch reaction plate with the holes(B) of the reverse clutch retainer as shown below, install them.

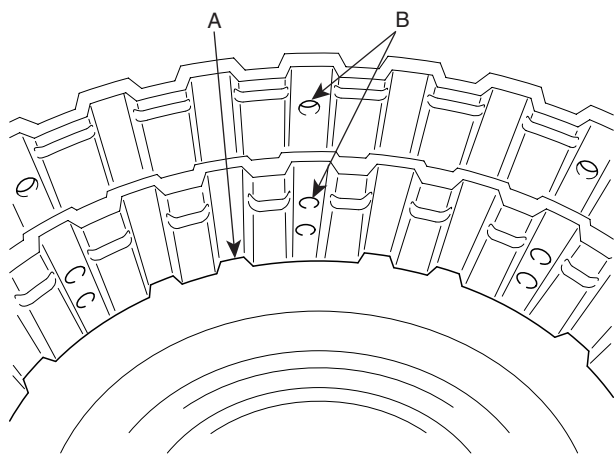

KKCF013Q

9. Applying 539.4~637.4N(55~65Kgf, 121.3~143.3lb) on the overdrive clutch reaction plates and 215.75~264.78kPa(2.2 ~ 2.7Bar, 31.29~38.40psi) air pressure through the inside hole after the installation of the snap ring, measure the endplay. When the end play exceeds the standard value, select an appropriate snap ring from the table below.

End play: 1.0 ~ 1.2mm(0.0394~0.0472inch)

Part No.	Thickness(mm/inch)
45427-39520	2.0 (0.0787)
45427-39521	2.1 (0.0827)
45427-39522	2.2 (0.0866)
45427-39523	2.3 (0.0906)
45427-39524	2.4 (0.0945)
45427-39525	2.5 (0.0984)
45427-39526	2.6 (0.1024)
45427-39527	2.7 (0.1063)
45427-39528	2.8 (0.1102)
45427-39529	2.9 (0.1142)
45427-39530	3.0 (1.1181)
45427-39519	1.9 (0.0748)
45427-39516	1.6 (0.0630)
45427-39517	1.7 (0.0669)
45427-39518	1.8 (0.0709)

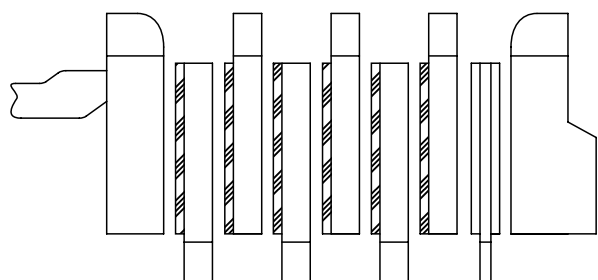

KKCF005W

8. Install the overdrive clutch reaction plate snap ring(A).

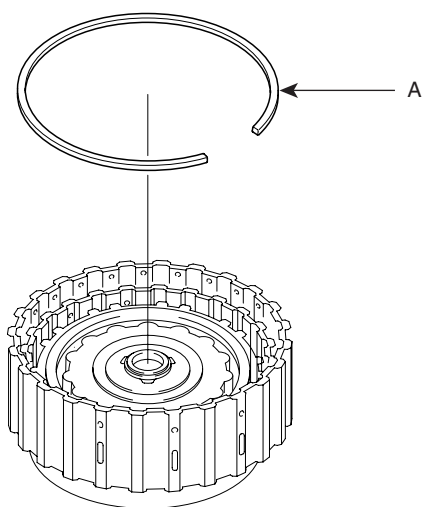

KKCF013E

10. Aligning the teeth(A) of the reverse clutch discs(2EA) & plates(2EA) and clutch reaction plate with the holes(B) of the reverse clutch retainer as shown below.

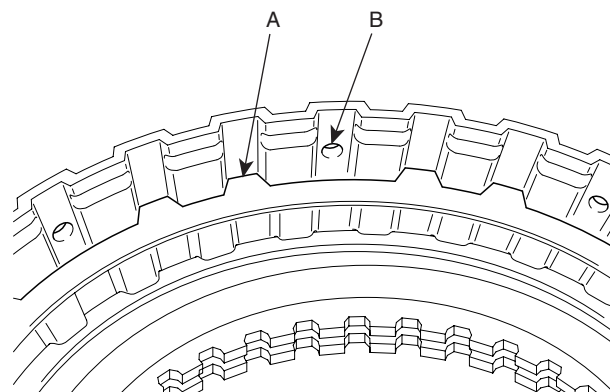

KKCF013R

**AUTOMATIC TRANSAXLE SYSTEM**

11. After installing the reverse clutch reaction plate snap ring and applying the weight, 1422.0~1520.0N(145~155Kgf, 319.7~341.7lb) on the clutch disc set and 313.81~362.84 kPa(3.2 ~ 3.7Bar, 45.51~52.63psi) air pressure through the inside hole, measure the end play. If the end play exceeds the standard value, select an appropriate snap ring from the table below.

---

End play: 1.5 ~ 1.7mm(0.0591~0.0669inch)

---

Part No.	Thickness(mm/inch)
45432-39518	1.8 (0.0709)
45432-39517	1.7 (0.0669)
45432-39516	1.6 (0.0630)
45432-39519	1.9 (0.0748)
45432-39528	2.8 (0.1102)
45432-39527	2.7 (0.1063)
45432-39526	2.6 (0.1024)
45432-39525	2.5 (0.0984)
45432-39524	2.4 (0.0945)
45432-39523	2.3 (0.0906)
45432-39522	2.2 (0.0866)
45432-39521	2.1 (0.0827)
45432-39520	2.0 (0.0787)

**SECOND BRAKE**

**COMPONENTS** EFDAFD86

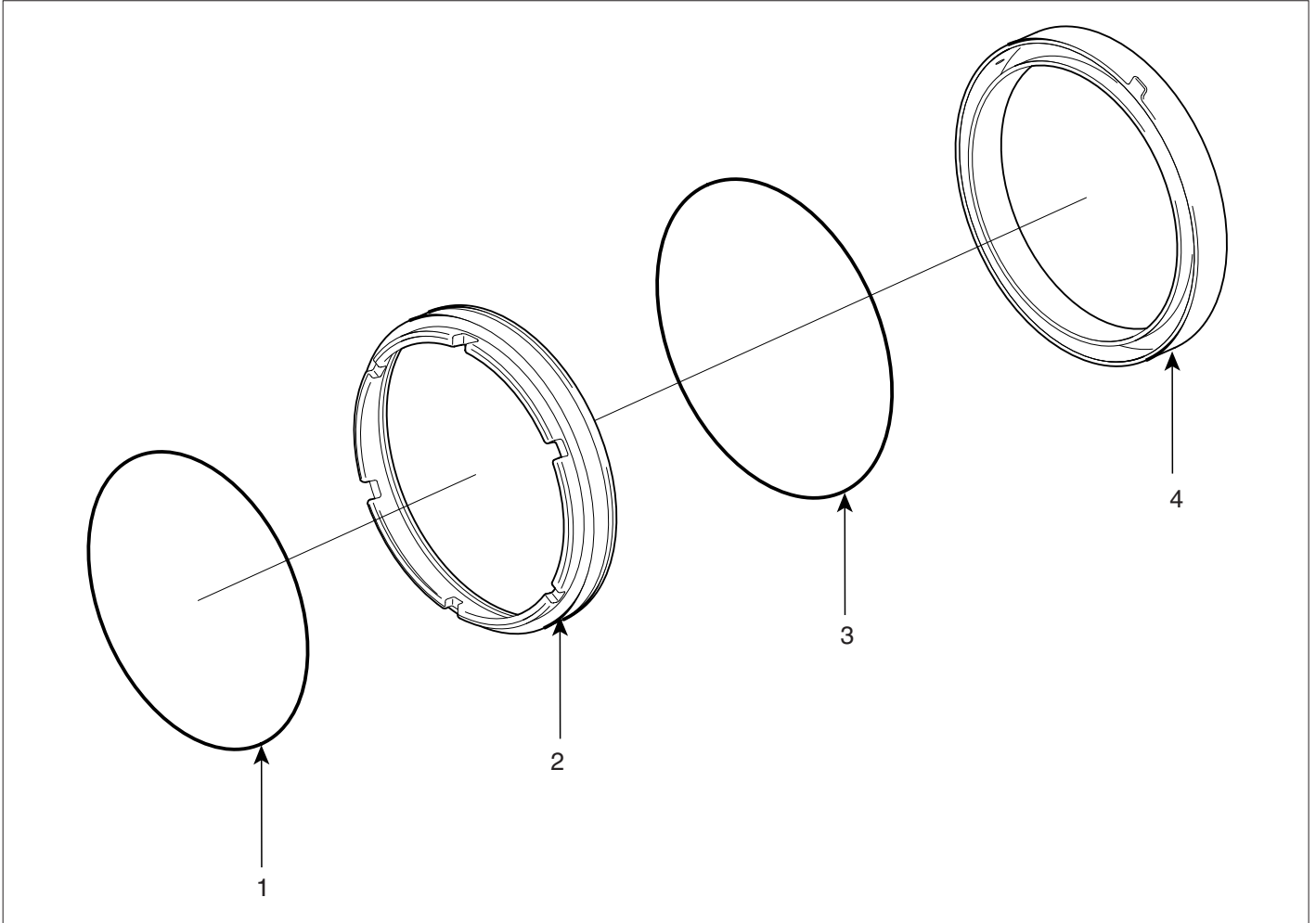

- 1. D-ring
- 2. 2nd brake piston

- 3. D-ring
- 4. 2nd brake retainer

EKRF502A

**DISASSEMBLY** E5F00582

1. Applying compressed air to the hole(C) of the 2nd retainer(A), remove the piston(B).

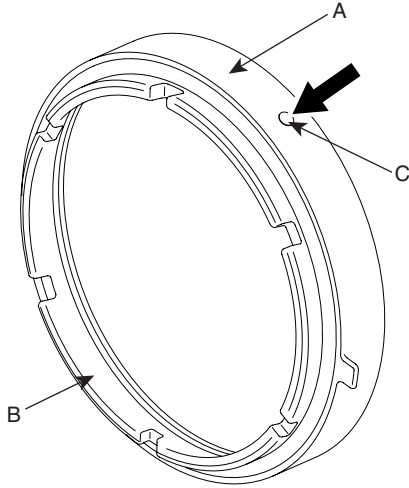

KKCF007B

2. Remove the D-rings(2EA) from the 2nd brake piston.

**REASSEMBLY** EA5D9DE6

Reassembly is in the reverse order of disassembly. All the D-rings should be replaced with new ones and inserted with care after applied ATF or white vaseline on.

**DIRECT CLUTCH**

**COMPONENTS** E2CFA79A

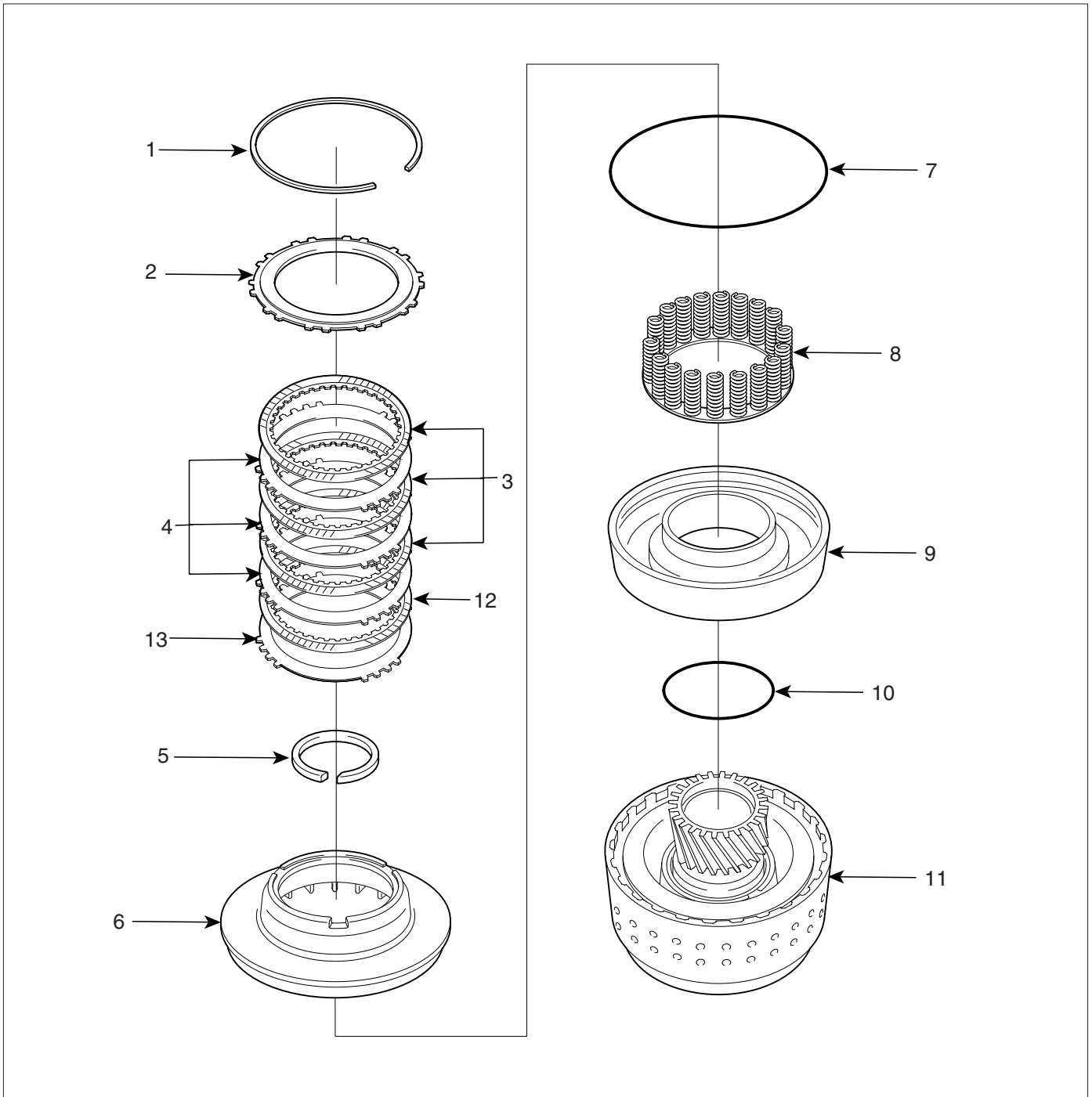

- 1. Snap ring
- 2. Clutch reaction plate
- 3. Clutch disc
- 4. Clutch plates
- 5. Snap ring
- 6. Direct spring retainer

- 7. D-ring
- 8. Return spring
- 9. Direct clutch piston
- 10. D-ring
- 11. Direct clutch retainer
- 12. Cushion plate
- 13. Pressure plate

**AUTOMATIC TRANSAXLE SYSTEM**

**DISASSEMBLY** EF2CFA8D

1. Remove the direct clutch snap ring(A).

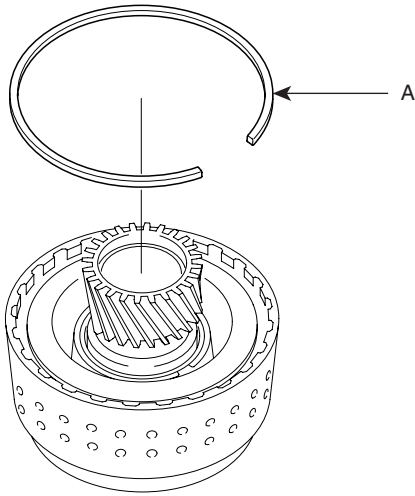

KKCF012B

2. Remove the clutch reaction plate(A).

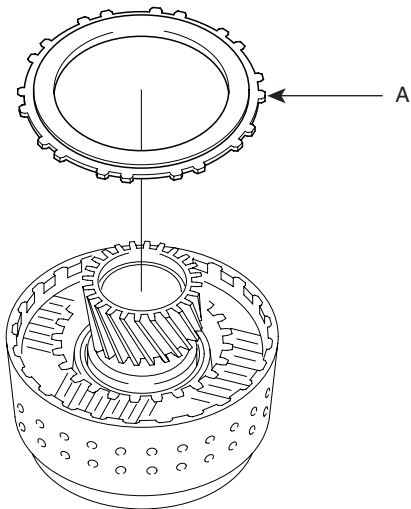

KKCF012C

3. Remove the clutch discs(A-3EA), plates(B-3EA), cushion plate(C-1EA) and pressure plate(D-1EA).

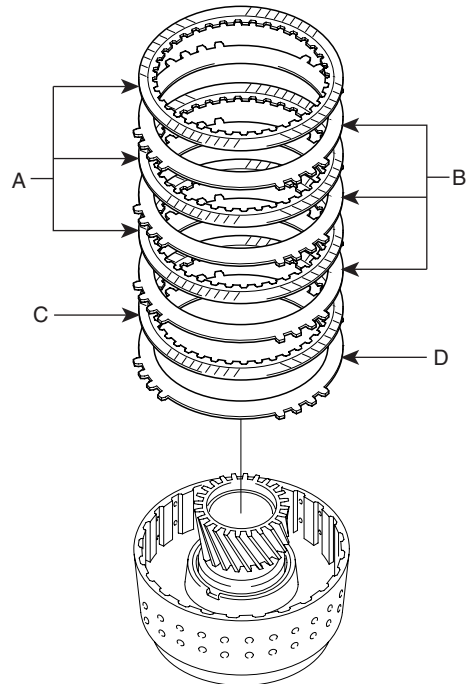

KKCF012D

4. Using the SST(09453-4C400) and a press machine(A), remove the snap ring(B).

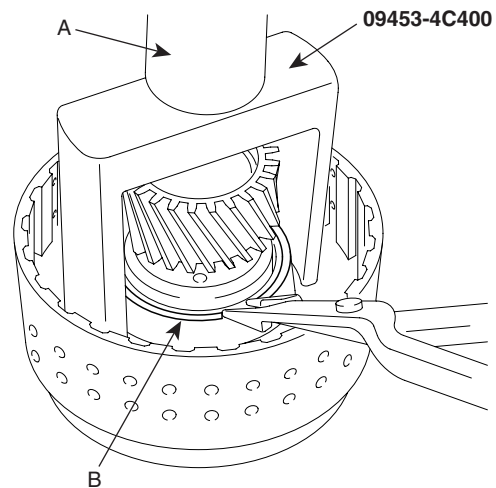

KKCF012E

**AT -80**

**AUTOMATIC TRANSAXLE (A5HF1)**

5. After removing the direct spring retainer(A), separate the D-ring from the retainer(A).

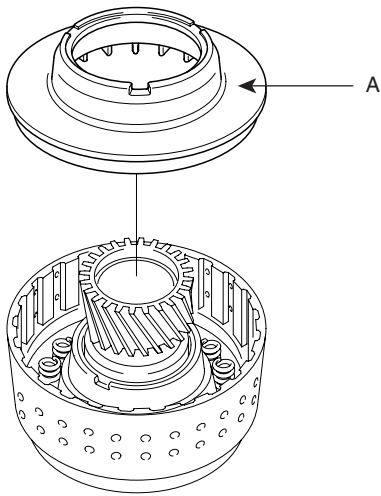

KKCF012F

7. Inflict air pressure as follows and remove the direct clutch piston(A) and the D- rings(B-2EA).

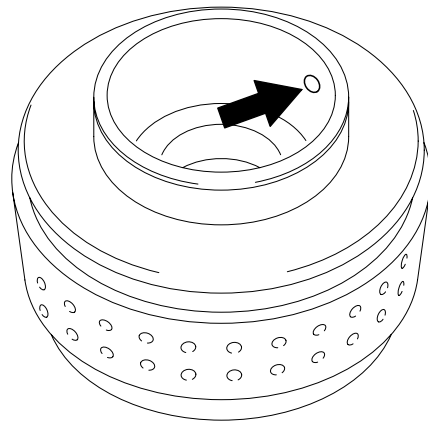

KKCF012H

6. Remove the return spring(A).

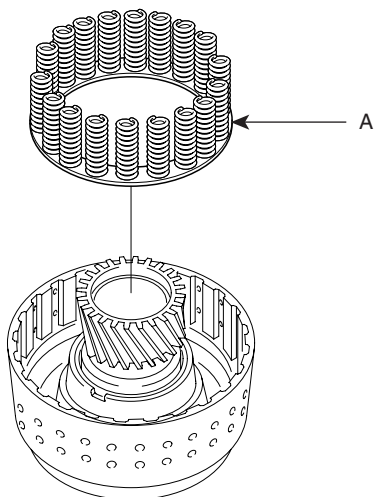

KKCF012G

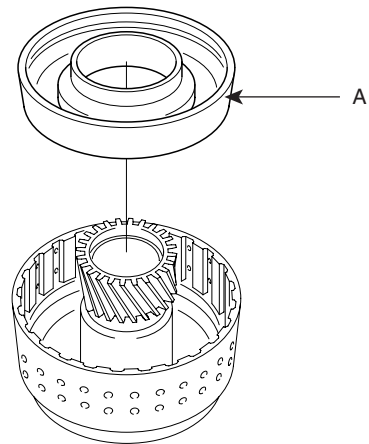

KKCF012I

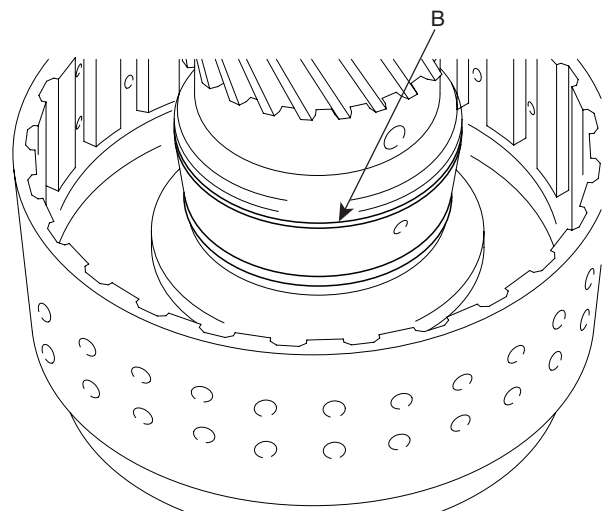

KKCF012J

**REASSEMBLY** EA839E3D

1. Inserting the D- rings to the direct clutch retainer and piston(A), install the piston inside the retainer.

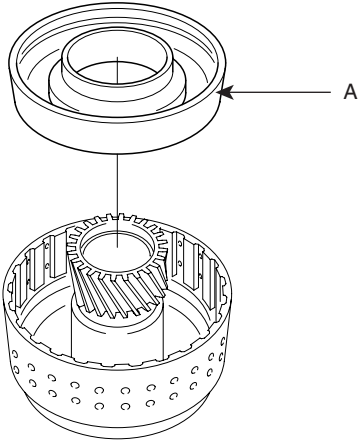

KKCF012I

2. Putting the D- ring in the spring retainer(A), install the return spring and the retainer.

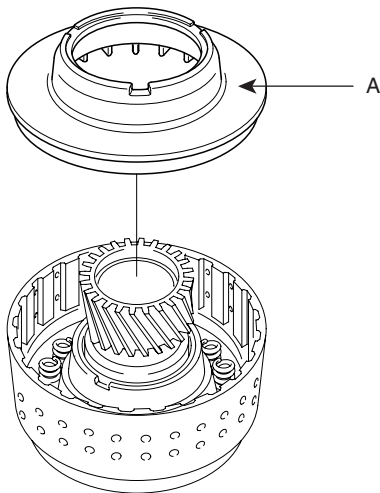

KKCF012F

3. Using the SST(09453-4C400) and a press machine(A), fix the snap ring(B).

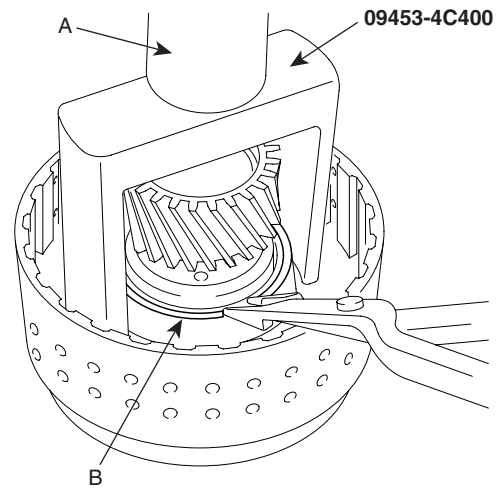

KKCF012E

4. Assemble homologizing tooth department(A) of the clutch plate, clutch disk and clutch reaction plate with the direct clutch retainer hole(B).

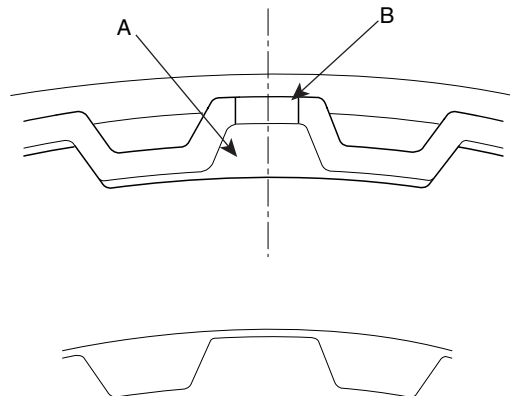

KKCF012K

5. Applying 49N(5Kgf,11lbf) weight on the direct clutch reaction plate and 245.17kPa(2.5 Bar, 35.56psi) pressure through the hydraulic line, measure the end play with a thickness gauge(A).

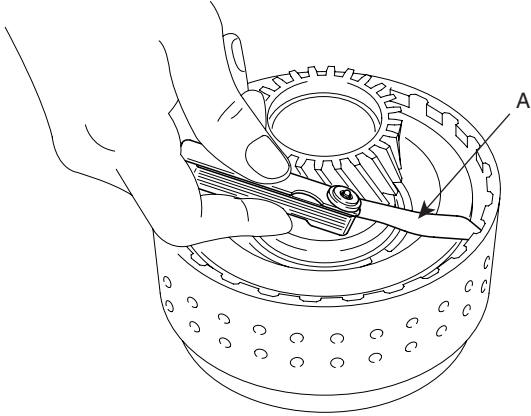

KKCF012L

---

End play: 0.6 ~ 0.8mm(0.0236~0.0315inch)

---

Part No.	Thickness(mm/inch)
45556-39520	2.0 (0.0787)
45556-39521	2.1 (0.0827)
45556-39522	2.2 (0.0866)
45556-39523	2.3 (0.0906)
45556-39524	2.4 (0.0945)
45556-39525	2.5 (0.0984)
45556-39526	2.6 (0.1024)
45556-39527	2.7 (0.1063)
45556-39528	2.8 (0.1102)
45556-39529	2.9 (0.1142)
45556-39530	3.0 (1.1181)
45556-39519	1.9 (0.0748)

**DIRECT PLANET CARRIER ASSEMBLY**

**COMPONENTS** EFB4FFF3

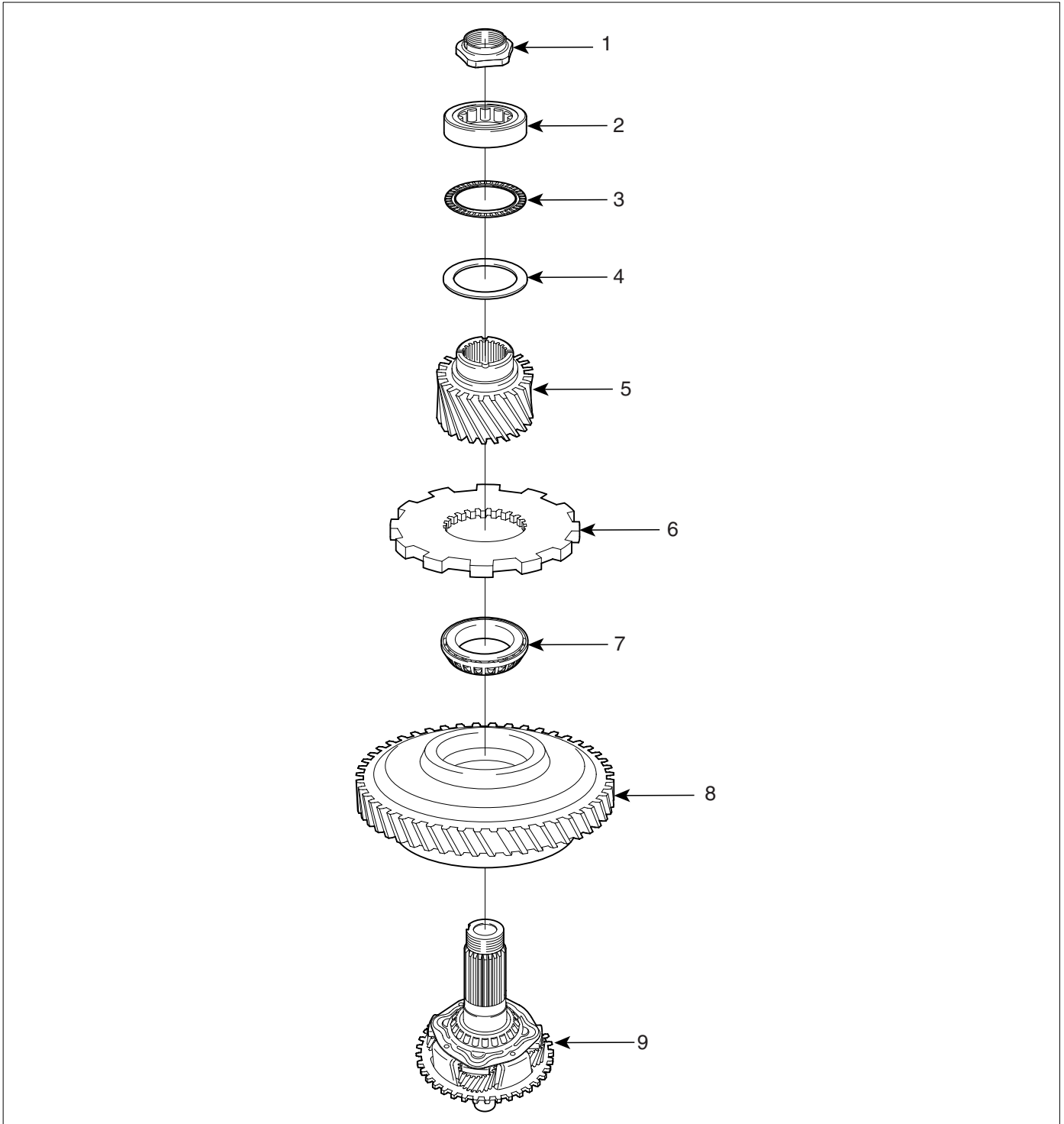

- 1. Lock nut
- 2. Roller bearing
- 3. Thrust bearing
- 4. Thrust race
- 5. Output gear
- 6. Parking gear
- 7. Taper roller bearing
- 8. Transfer driven gear
- 9. Direct planetary carrier

**DISASSEMBLY** EBF058FF

1. Do caulking floppily so that the lock nut can rotate.
2. After fixing gear assembly(B) in a vise, remove the lock nut(A).

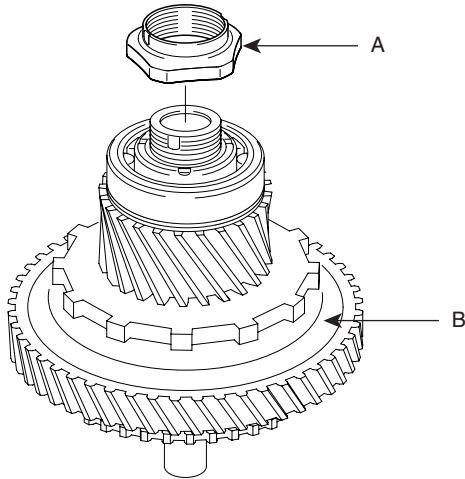

KKCF011B

3. Remove the roller bearing(A).

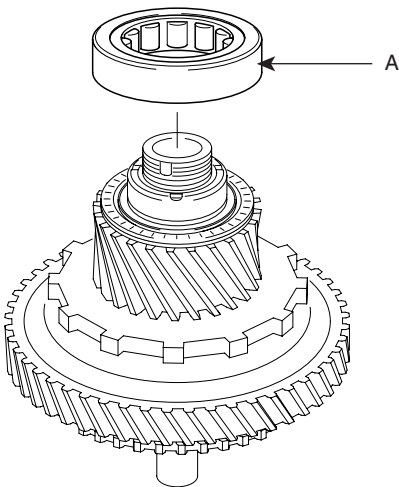

KKCF011C

4. Remove the thrust bearing(A) and race(B).

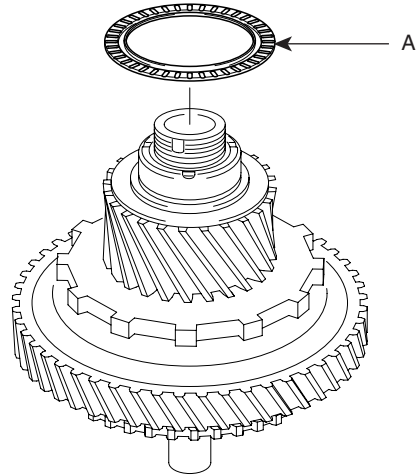

KKCF011D

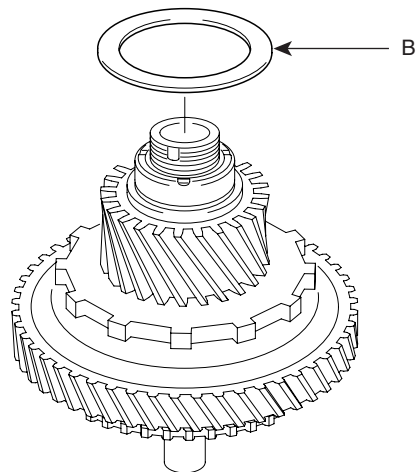

KKCF011E

5. Engage the transfer driven gear(C) to a press machine(A), inflict pressure and take the output gear(B).

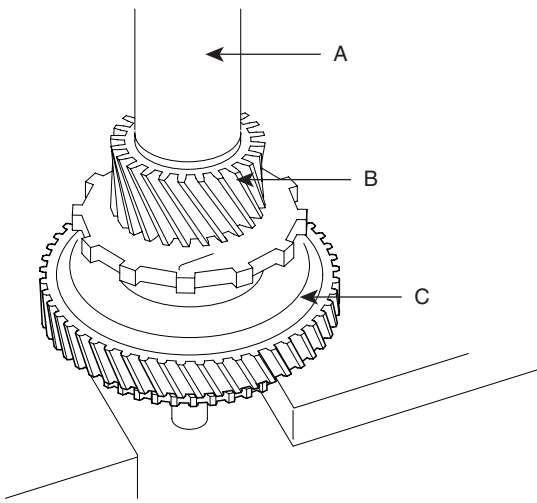

KKCF011F

7. Remove the taper roller bearing(A).

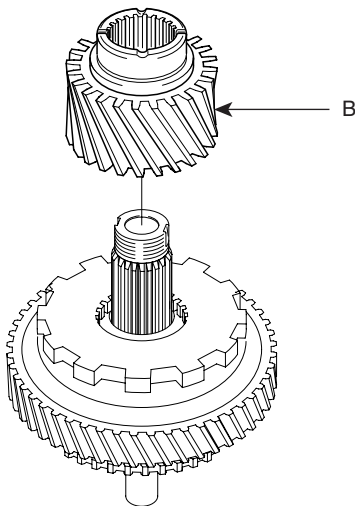

KKCF011G

6. Remove the parking gear(A).

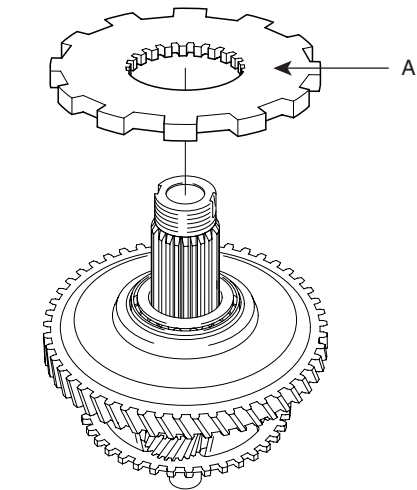

KKCF011H

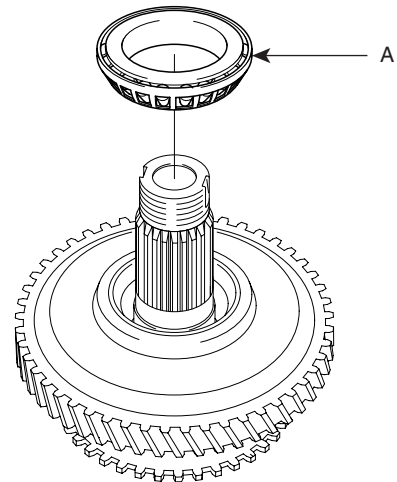

KKCF011I

8. Remove the transfer driven gear(A).

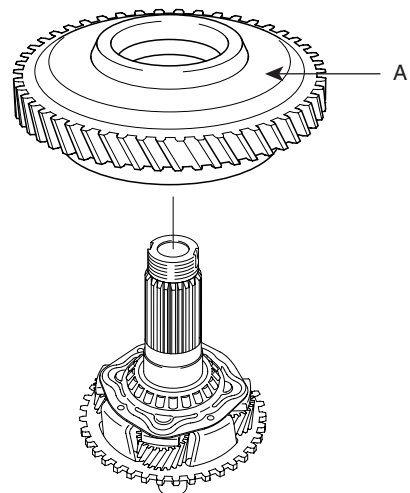

KKCF011J

**REASSEMBLY** E18AF18F

1. After inserting the transfer driven gear(A), install the taper roller bearing(C) by using a press machine(B).

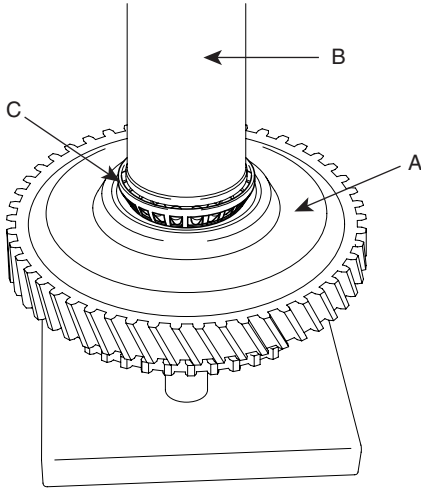

KKCF011K

2. After inserting the parking gear(A) and the output gear(B), install them with a press machine(C).

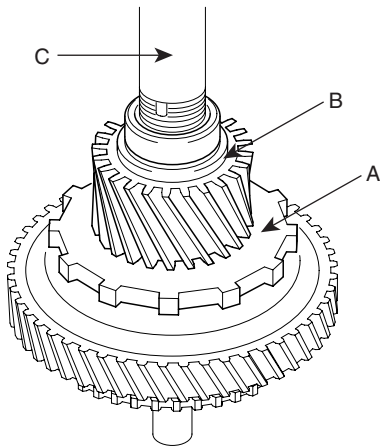

KKCF011L



**NOTE**

At the parking gear's assembly, the grooved surface heads lower part.

3. After installing the thrust race and bearing, install the roller bearing(A).

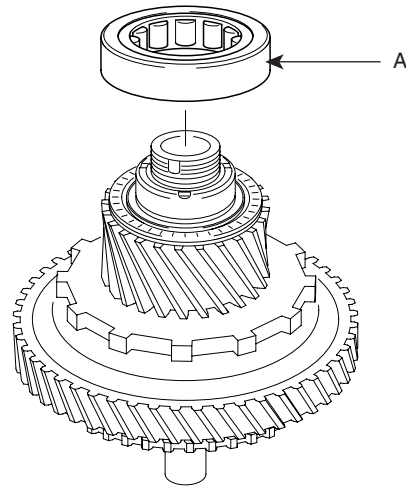

KKCF011C

4. After fixing the gear assembly(B) in a vise, tighten the lock nut(A) and do caulking.

**TORQUE :**

156.9~176.5Nm(1600~1800 Kgf.cm, 115.7~130.2 lb-ft)

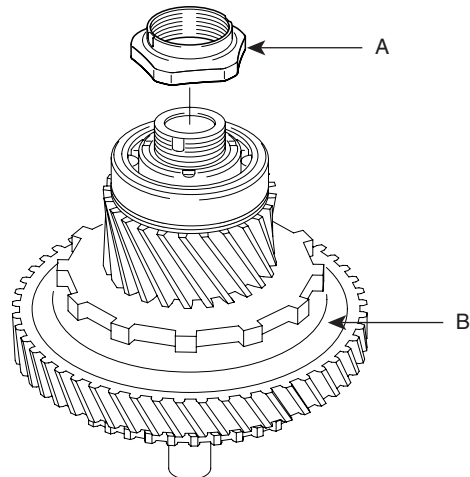

KKCF011B