

VALVE BODY AND MECHATRONIC SERVICE

ZF 6HP19/26
AW TR-60SN/09D



AUTOMATIC CHOICE
Bristol U.K.
May 7, 2011

By
Bob Warnke

ZF 6HP – Ford 6R60, Mechatronic Service

This information is intended as an introduction to and service for the ZF 6/Ford 6R60 Mechatronic assembly.

Identification:

The ZF 6 has two significant generations, the 2002-2005, ZF 6HP/19, 26, 32 and the 2006 to current 6HP/21, 28, 34. In 2006, the Mechatronic unit was upgraded to improve shift response. The later, eliminated the SS1/ Reverse engagement accumulator and has revised EDS solenoids. (Fig. 1)

The “M” has a mechanical linkage to position the manual valve. The “E” version uses a solenoid to position the manual valve and park lock.

The 2002 to 2005 “M” version, has three yellow and blue solenoids, the 2006 and later “M” version, has two orange EDS solenoids. Within both vintages there is an “M” version manual valve and the “E”, solenoid controlled manual valve. The “E” version in both early and late will have nine solenoids, one visible at the end of the manual valve.

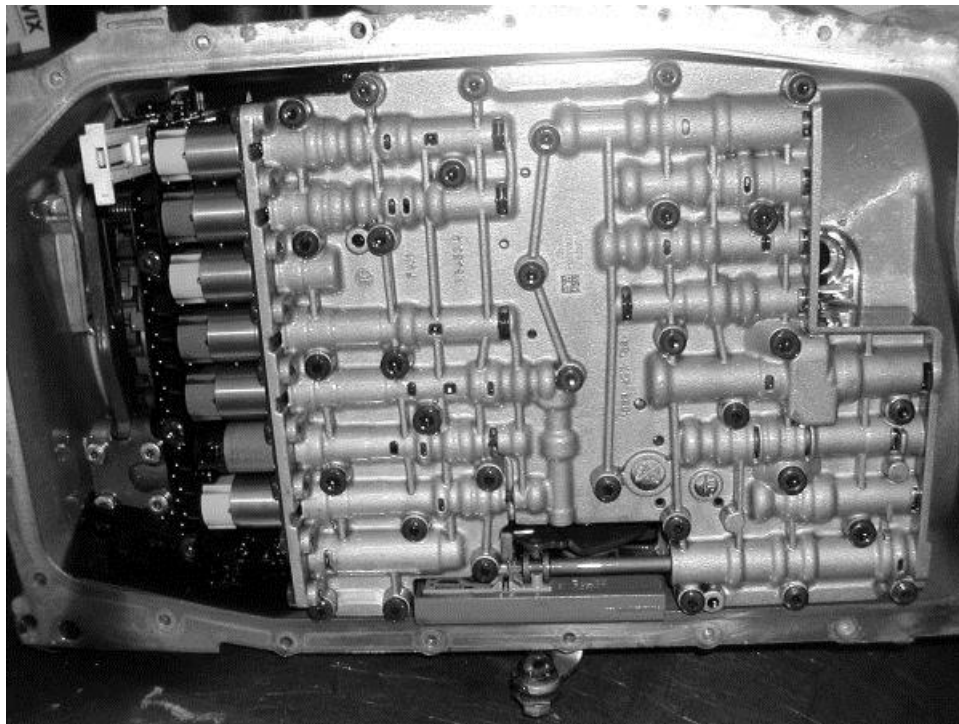

Fig. 1a

ZF 6HP19
 2002-2005 Manual Valve Version (Sonnax repairs applicable)

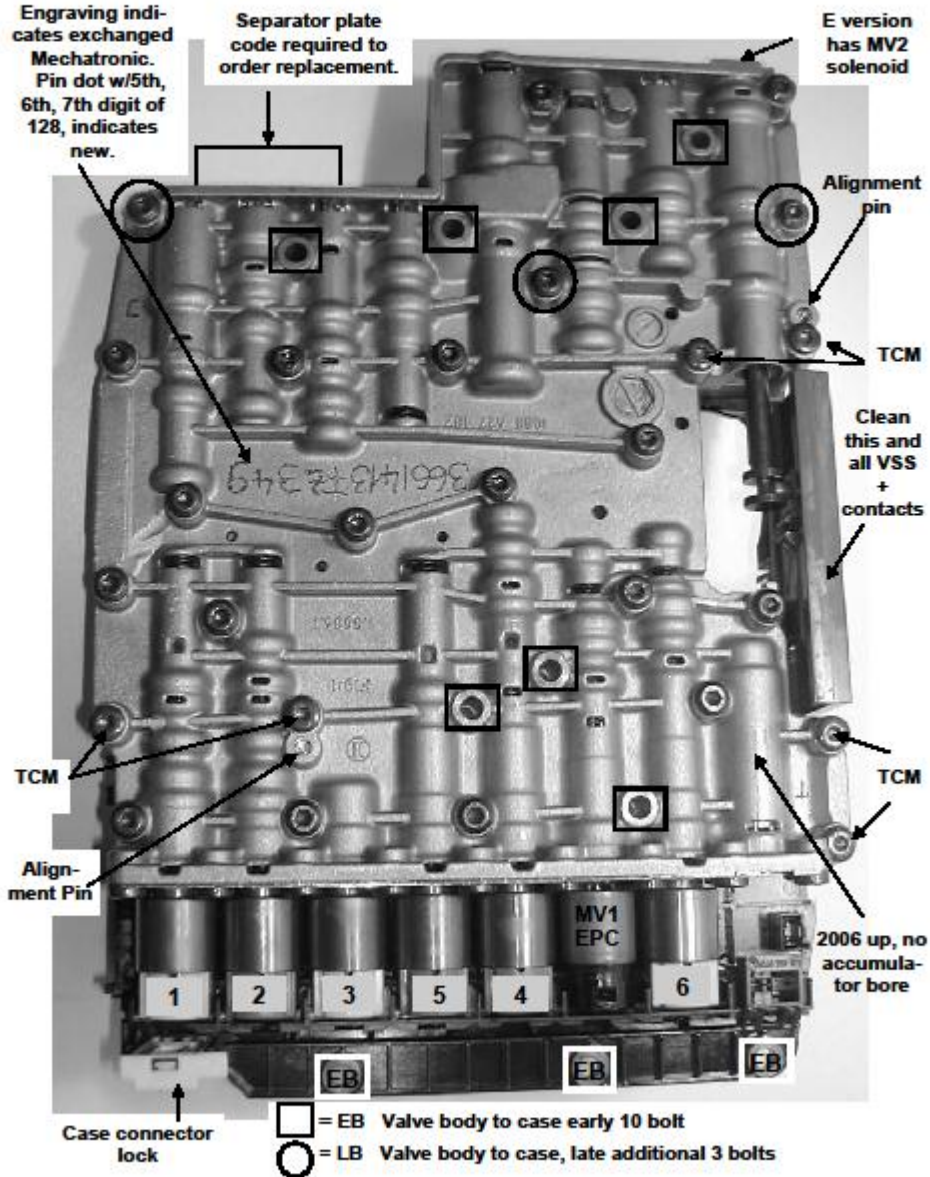

Fig. 1

Mechatronic programming:

As indicated on Fig. 1, an engraving identifies this Mechatronic as a serviced/exchange unit. This exchange unit may have a blue paint dot, on the solenoid end of the plastic frame, next to the bar code part number. This blue dot indicates it is NOT programmed. A blue dot indicates it must be flashed with vehicle application prior to installation.

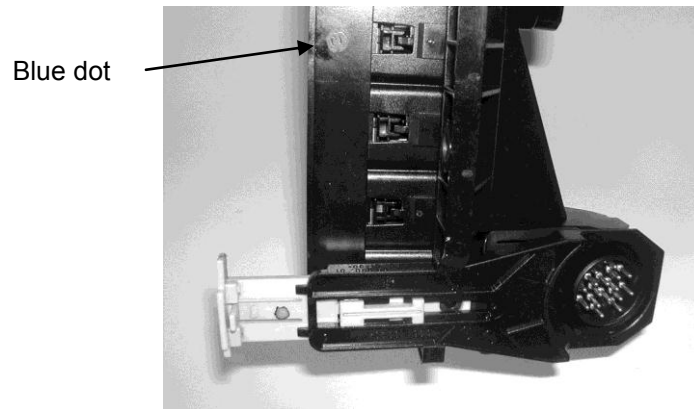

Fig. 2

A white dot, in the same area, indicates it HAS been programmed with a base operating parameter. It can be installed onto an operating transmission, but will require adaption.

A new Mechatronic will NOT have the engraving as pictured in Fig. 1. It will have a pin-dot serial number. Within that, the 5, 6,7th digit of 128, indicates this is a NEW unit and needs to be programmed.

Mechatronic Removal

The chassis harness screws off the case connector. This connector or pass-through sleeve cannot be removed, nor the valve body removed, until the plastic TCM module is separated from the pass-through connector.

With the oil pan removed, near the connector you will find a white horizontal plastic bar, with a locking tab. Release the center tab and pull the white slide away from the case connector. It will require .855 inch or 21.7 mm of extension. When the white slide bar is fully extended, the case pass-through sleeve can be removed.

The 10 or 11 valve body to case bolts requires a #40 Torx bit. They can be identified as having a larger and taller head than the valve body retention bolts. (Refer to Fig. 1)

ESD Precaution:

Electrostatic discharge can damage the control module, which is located within the plastic housing. An ESD bracelet is suggested during any handling (transmission or bench) of the Mechatronic assembly. Caution against touching the connecting pins.

Experience will indicate if this invisible ESD is a menace, but until proven otherwise, better safe than sorry, buckle up. DSD bracelets, floor and bench pads as well as bench grounding precautions are suggested.

TCM frame removal:

You must remove 6 bolts indicated as TCM, (Fig. 1). The entire plastic board will then slide away from the casting on TWO guide pins. Supply equal force on these two pins from the lower VB side.

The molded housing contains a transmission and vehicle specific control module. HANDLE with CARE. At this time the module is ONLY supplied with a complete Mechatronic. The Mechatronic is programmed to your vehicle. If damaged, there could be an additional core charge of \$450.00 USD added to the cost of an OE replacement.

Cleaning:

The plastic board, the manual lever Hall affect sensor and all electrical contacts should be cleaned well with brake cleaner or electrical cleaner. Do not use carburetor cleaners or harsh solvents. The interior of the valve body should be cleaned in the same way. DO NOT subject the separator plate or the case to valve body adapter to these chemicals!

The foam insulator on the solenoid bridge, protects them from metal particle cross voltage. It should be cleaned and replaced. The TCM plastic circuit protection can be removed, but this is not required.

Hydraulic Control Assembly

Valve body casting separation:

Half-moon openings, at the mid-section at the manual valve and at the opposite corner are used as leverage points to separate the plate from the castings.

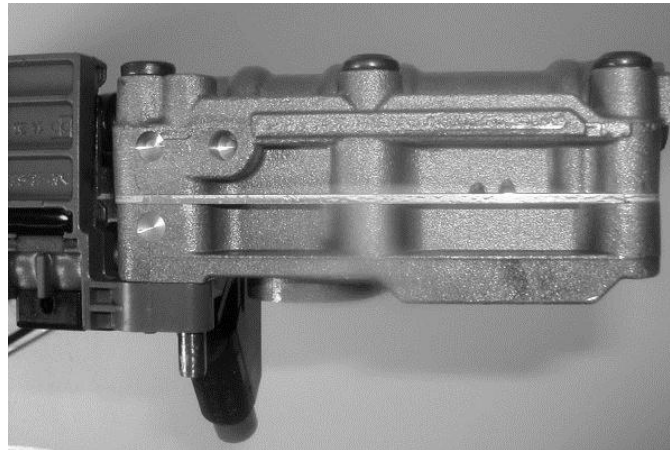

Fig. 4

Bonded separator plate:

The plates are calibration specific, requiring either the transmission part number or an existing plate ID number, to reorder. Replacement plates are available from ZF/ Ford and aftermarket sources.

The plate has a bonded gasket which mates to the castings. In some instances, the castings can be separated without disturbing the gasket and the plate is reused. In other instances, the valve body sections need to be pried apart, which often delaminates the gasket.

It has been reported, that resurfacing the valve body and chemically stripping the remaining gasket, has worked when time or parts are an issue.

Valve body inspection and vacuum testing:

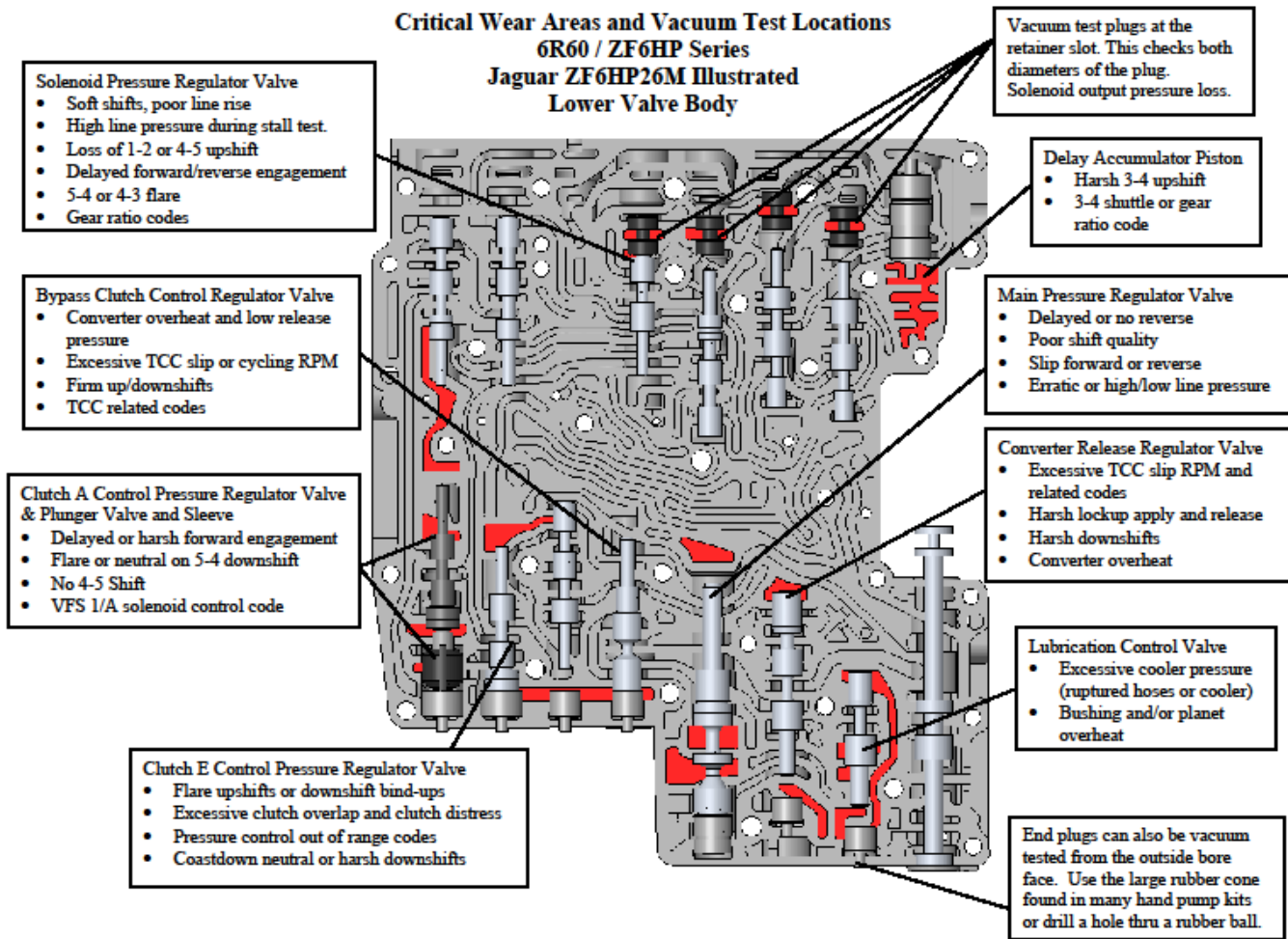

Critical Wear Areas and Vacuum Test Locations
6R60 / ZF6HP Series
Jaguar ZF6HP26M Illustrated
Upper Valve Body

Clutch D1 Control Pressure Regulator Valve

- Flare upshifts or downshift bind-ups
- Excessive clutch overlap and clutch distress
- Pressure control out of range codes
- Coastdown neutral or harsh downshifts

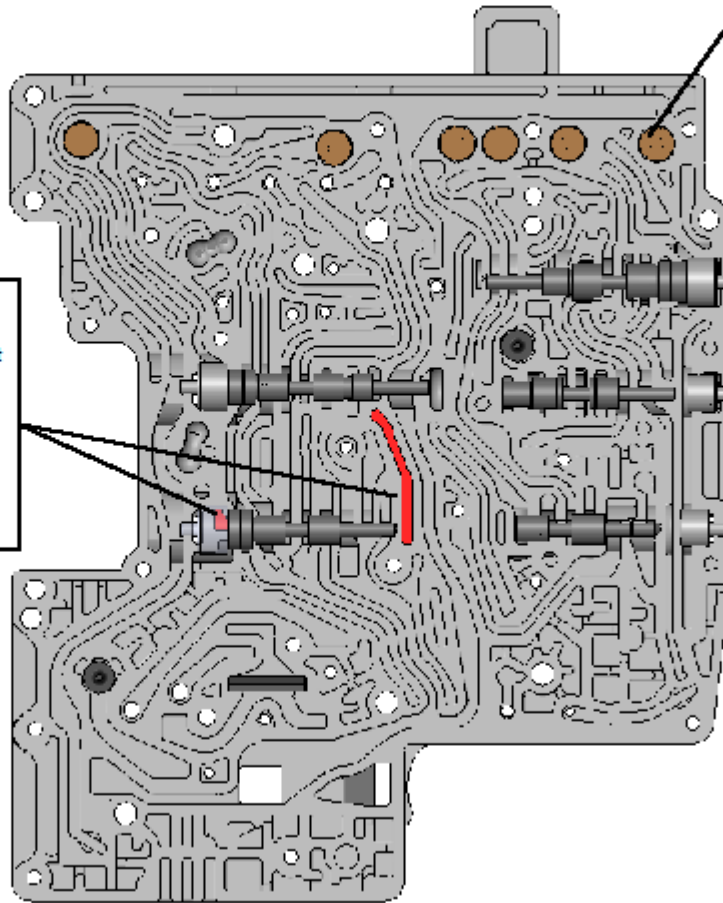

OEM accumulator pistons should be flush with the casting. It is common for the rubber insert to lose tension.

Each of these pistons can be vacuum tested from the exhaust hole on the opposite side of the casting.

6R60 / ZF6HP Series
Jaguar ZF6HP26M Illustrated
Lower Valve Body

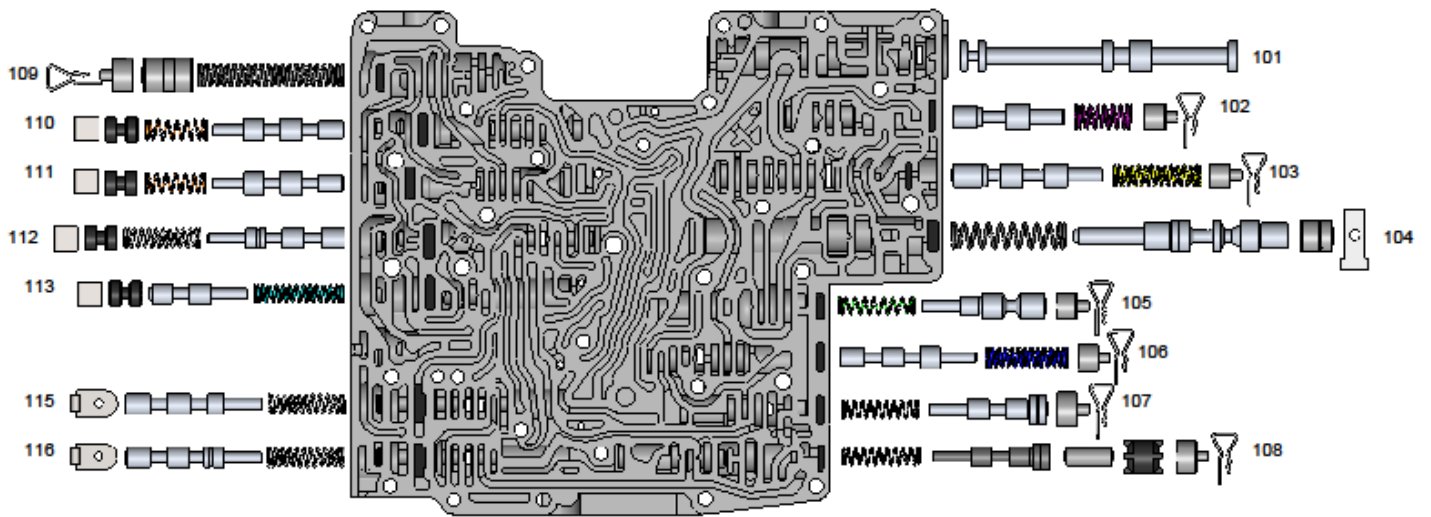

6R60 / ZF6HP Series
Jaguar ZF6HP26M Illustrated
Upper Valve Body

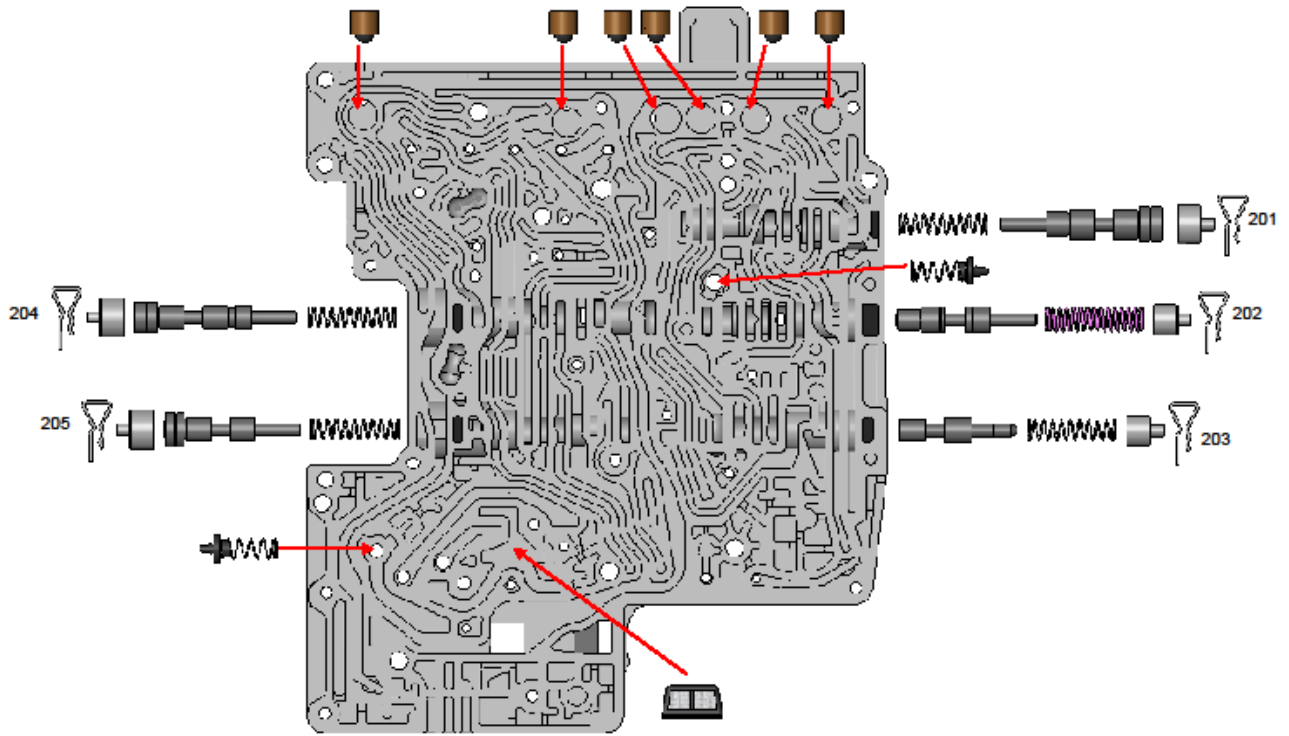

6R60 / ZF6HP Series Component Description and Location

Number	Location	Description
101	Lower Valve Body	Manual Valve
102	Lower Valve Body	Lubrication Control Valve
103	Lower Valve Body	Converter Release Regulator Valve
104	Lower Valve Body	Main Pressure Regulator Valve
105	Lower Valve Body	Bypass Clutch Control Regulator Valve
106	Lower Valve Body	Clutch E Latch Valve
107	Lower Valve Body	Clutch E Control Pressure Regulator Valve
108	Lower Valve Body	Clutch A Control Pressure Regulator Valve
109	Lower Valve Body	Delay Accumulator Piston
110	Lower Valve Body	Solenoid Multiplex Valve
111	Lower Valve Body	Drive Enable Valve
112	Lower Valve Body	Clutch D1 Latch Valve
113	Lower Valve Body	Solenoid Pressure Regulator Valve
115	Lower Valve Body	Clutch B Latch Valve
116	Lower Valve Body	Clutch A Latch Valve
201	Upper Valve Body	Clutch B Regulator Valve
202	Upper Valve Body	Clutch D2 Regulator Valve
203	Upper Valve Body	Clutch D2 Latch Valve
204	Upper Valve Body	Clutch C Regulator Valve
205	Upper Valve Body	Clutch D1 Control Pressure Regulator Valve

Electronics/ Solenoids:

The TCM is flashed by OE, after qualifying the solenoids and hydraulic response. The TCM will then have a learned value or flow rate for each solenoid. Amperage is independent and controlled for each solenoid. So altering the flow rate of the solenoid (swapping out another) or modifying the valve body requires a relearn/adaption period.

The TCM is capable of limited solenoid adaptation, without reprogramming. This is true for minimal alteration of the hydraulics as well. As the valve bores wear, the TCM will adapt, until the window of adjustment and control is excessive. In many instances, the hydraulic control of the unit can be swapped out as long as the original TCM is reinstalled. Also solenoids can be individually exchanged with new OE or with qualified used. (This information is from successful field reports, within the aftermarket)

If the original solenoids are reused, they should be returned to the same location, due to their learned flow rate. After any service, resetting adapts and clearing the KAM, is suggested.

It is not advised to attempt circuit testing through the 16 pin connector. Note the ESD precautions! Check the solenoid resistance (5.0 ohms @ 20°C/68°F) with the circuit board removed. Do not use an ohmmeter with more than .6 voltage supply. There are three types of EDS solenoids, blue, black, yellow. (Refer to Fig. 4 for ID).

EDS Solenoids					
IDENTIFICATION	COLOR	LOCATION	OUTPUT	OHMS	FUNCTION
6HP 19/26/32	Green	EDS 1,3,6	0 bar @ 0 ma	5.05	1-A Clutch 3-C Brake 6-TCC
	Black/Grey	EDS 2,4,5	4.6 bar @ 0 ma	5.05	2-B Clutch 4-D and E 5-EPC
	Black	MVI	Open/closed	11.5	Selector valve
6HP 21/28/34	Orange	EDS 1,2	4.7 bar @ 0 ma	5.05	As above
	Yellow	EDS 4,5,6	4.6 bar @ 0 ma	5.05	As above
	Blue	EDS 3,7	0 bar @ 4.6 ma	5.05	3-C Brake 7-Logic
	Black	MV2	Open/closed	11.5	Park lock valve
	Green	MV3	Open/closed	11.5	Park lock cycle

Fig. 5

TCM CONNECTOR PIN INDEX		
PIN	M-ASSIGNED	E-ASSIGNED
1	Manual shift	Series line
2	CAN low	CAN low
3	ISO K line	ISO K line
4	Manual downshift	Not in use
5	Manual upshift	Not in use
6	CAN high	CAN high
7	Shift lock	Not in use
8	Not in use	Not in use
9	Terminal 15 Wake-up signal	Terminal 15 Wake-up signal
10	P line for starter inhibit	P line for starter inhibit
11	Shift lock Apply brake	Not in use
12	Not in use	Not in use
13	Terminal 31-1 Earth (ground)	Terminal 31-1 Earth (ground)
14	Terminal 30 (EGS supply voltage)	Terminal 30 (EGS supply voltage)
15	Interlock	Not in use
16	Terminal 31-2 Earth (ground) 2	Terminal 31-2 Earth (ground) 2

TCM CONNECTOR

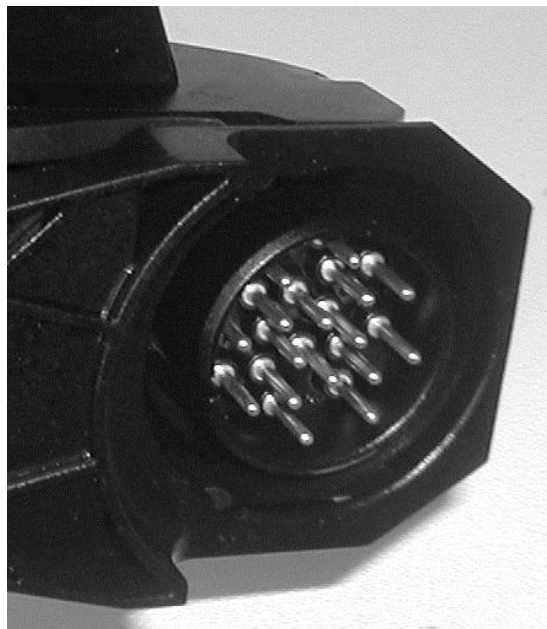

Fig. 6

Pin numbers are molded next to the pin in the housing

SOLENOIDS

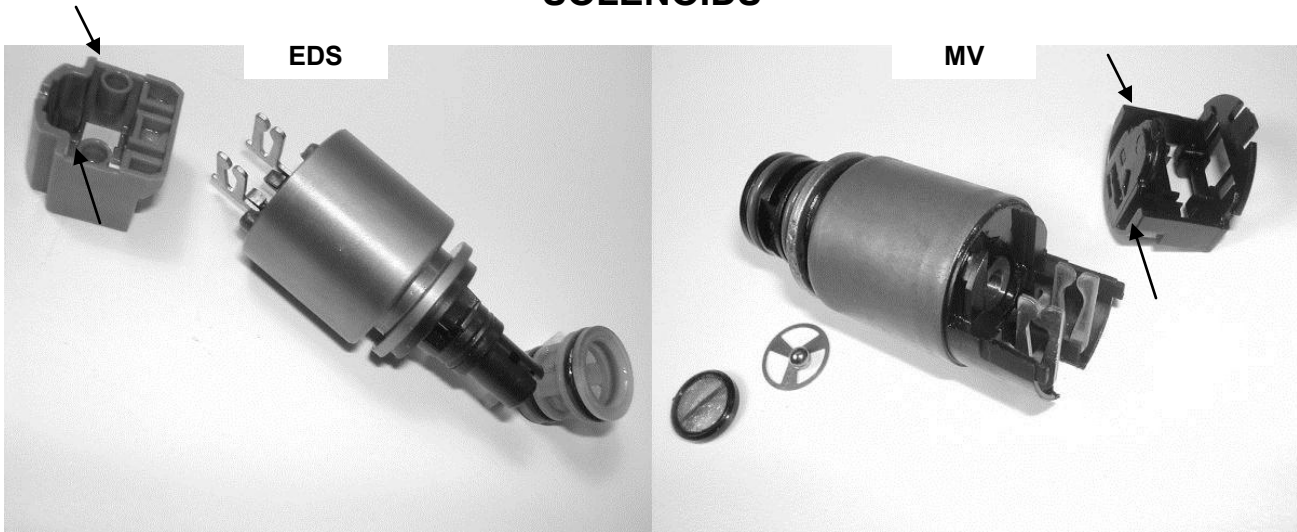

Fig. 7a

Fig. 7b

The connector insulator can be pried off (indicated by arrows) to inspect the solder joint at the coil.
Screens can be pried off to flush them from the inside.
The MV solenoid (Fig. 7b) screen retains a ball and spring.

DEMAGNETIZE

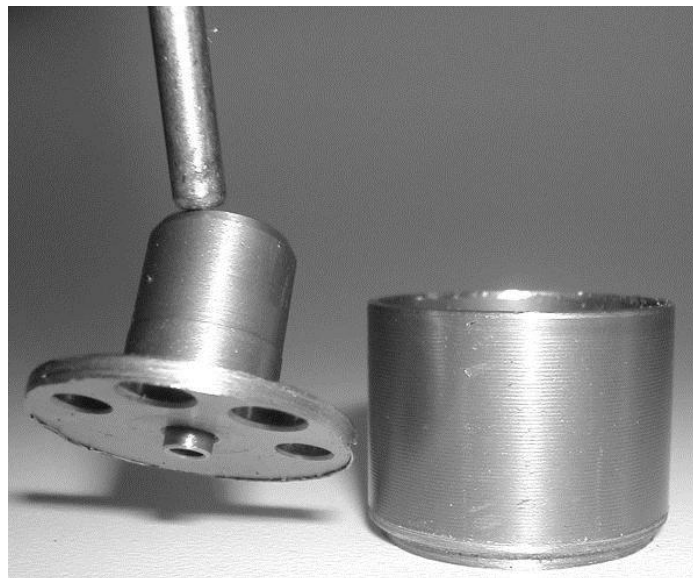

Fig. 8

A typical solenoid service includes demagnetizing the assembly.

The canister above has been cut off to expose the parts below.

EDS EXPLODED VIEW

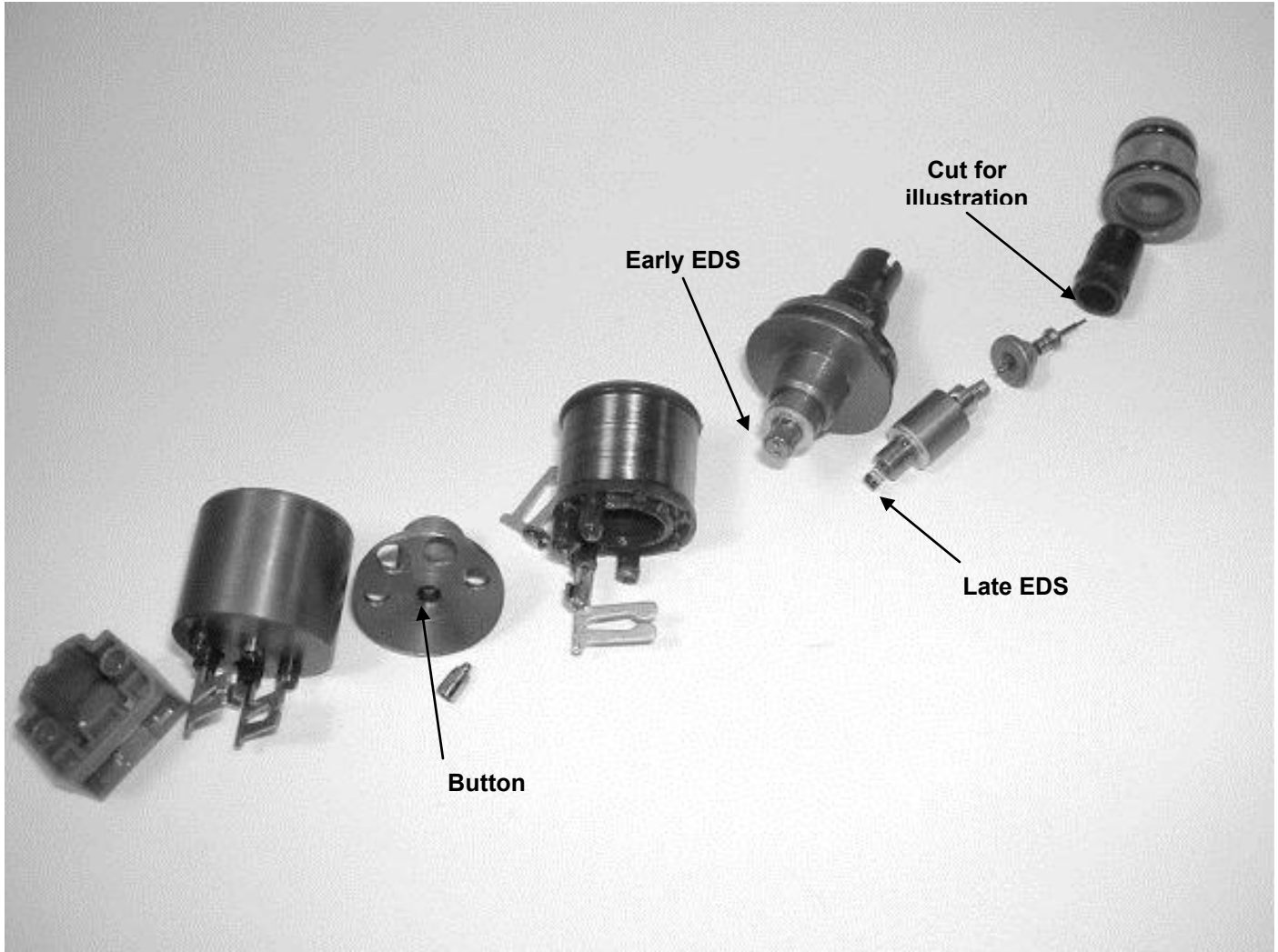

Fig. 9

This illustrates the difficulty in machine flushing or hand cleaning the internal parts.

The button is pressed into the canister to adjust the calibration. This press fit is minimal and results in setting solenoid output pressure. The typical measurement of this button to canister range is .040" to .060" (1.016 mm – 1.524mm)

Solenoid coil/pintle movement and the resulting flow are learned by the TCM. Relocating or altering will require a relearn procedure or drive time interval.

TCM Board (M type, 6HP 26)

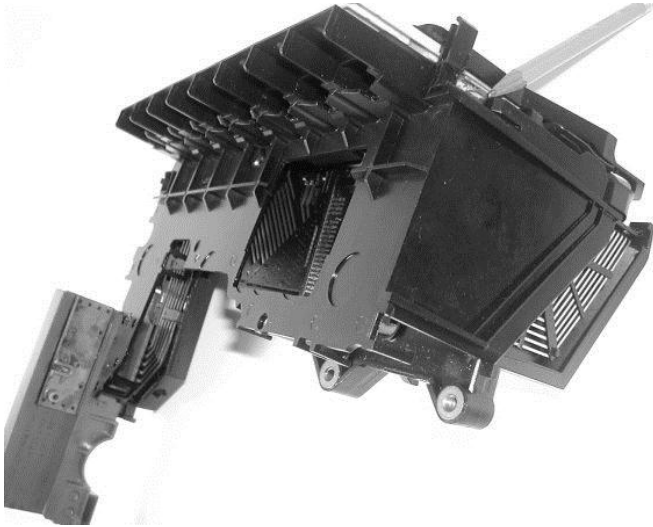

Fig. 10

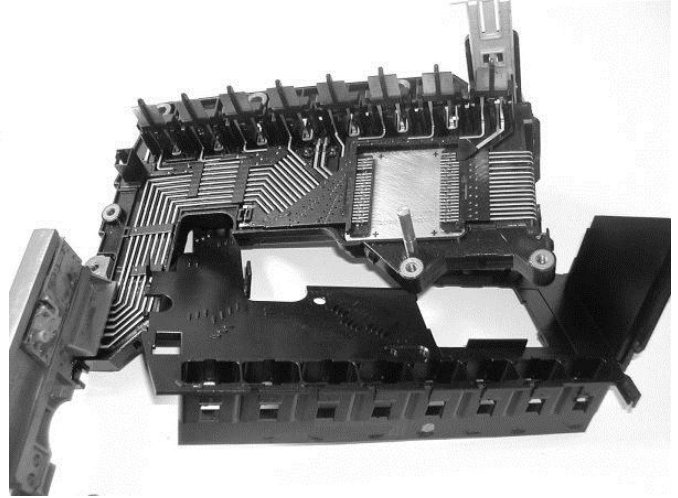

Fig.11

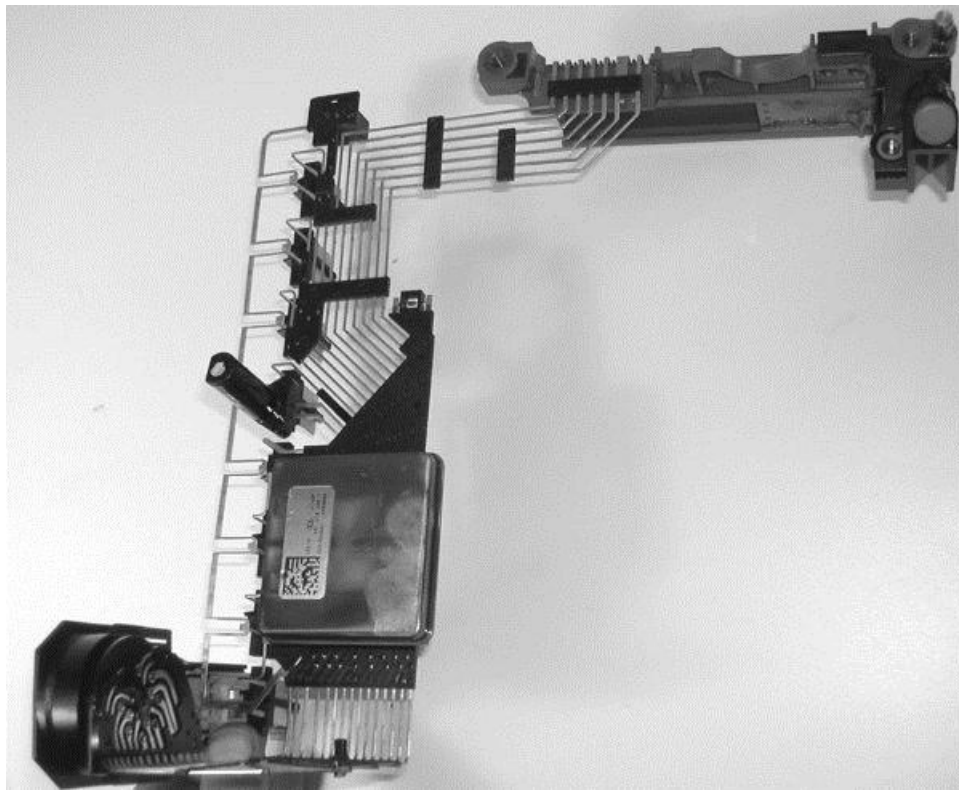

Fig. 12

Mechatronic Installation:

Insure the correct pump suction adapter is installed. ZF suggests this be replaced on every valve body R-R. The overall seal heights on these vary depending on application. Insure you have the correct part. Height of 6HP19/21 is 15.4 mm. Height of 6HP26/28/32 is 14.4mm.

Ford 6R60 thermal bypass valve. Front corner, between case and valve body. Spring installs into the case, followed by the thermal valve.

Mechatronic to case rubber tube seals. The longest (blue) resides next to the manual linkage, medium (green) next to it. The two shortest ones (black) are furthest from the linkage.

Mechatronic to case bolts are torqued at 6-8 Nm or 53 in lb. Finish torque from the center outward. Reverse the process to install the pass through. When the pass-through is fully engaged with the pins on the Mechatronic, there will be a gap of less than .120" or 3.0 mm. between the exterior of the case and the flanged edge on the connector

Drive-cycle, relearn and adaption:

Ford requires six light throttle up and coast down shift cycles (after obtaining 80°C, 175° F) for a partial relearn.

BMW, suggests all modules be reflashed, cleared of codes during a Mechatronic replacement. Field reports using the original, good TCM can reduce or avoid the OE recalibration.

ZF information notes adapts should be set to -0-, with any Mechatronic service.

The relearn should include multiple drive and coast cycles below 2,000 RPM.

Garage shifts should also be performed after obtaining operating temperature.

Drive-ability Concerns and Corrections:

- **Slip in Reverse, Harsh shifting once hot, 4-5 slip or flare.**
 - Valve body hydraulic service.

- **Range codes, failsafe condition**
 - Clean internal range sensor

- **Erratic shifting**
 - Low fluid level, which is one of the most common and overlooked issues on the 6HP. Check for OE reflash of various shift concerns.

- **3-4/4-3 clutch squawk**
 - Incorrect fluid, lack of friction modifier. Modifier # S671 090 288

- **Blown E clutch snap ring**
 - Install updated E drum

- **Loss of Park**
 - Bent electronic shift linkage, also can be caused by incorrect emergency cable adjustment.

- **TCC shudder or RPM swing.**
 - Incorrect type of fluid. Must flush complete and possibly multiple times.
 - Lockup clutch de-bonding issue.
 - O-ring on the converter piston id. leaking.
 - Incorrect converter damper not matched to the engine.
 - Incorrect TCC friction material.
 - Check for possible reflash.

- **Immediate failsafe after Mechatronic service.**
 - Chassis harness to case is not fully engaged.
- **Limited vehicle speed, not exceeding 13 km/8 mph.**
 - Mechatronic not programmed to the vehicle.
- **Moan or growl noise on coast down shifts.**
 - Possible internal driveline issues, such as bushings or bearings.
- **Early downshifts.**
 - Check engine performance first.
- **No engagement, forward or reverse**
 - Battery and alternator voltage less than 9.0 volts or over 16 volts causes erratic trans control.
- **3rd or 5th failsafe/ default mode.**
 - A TCM temperature out of range can create this. Check cooler and air flow.
- **Harsh Shifts.**
 - Possible trans. fluid temperature sensor or solenoid out of range.
 - Two temperature sensors on TCM. One for trans temp and one for TCM temp. If either goes over 170C /338F trans & TCM will shut down.
- **Engine will not crank.**
 - Defective park neutral switch.
- **Transmission will not adapt, may operate at maximum line pressure, no clutch actuation, MIL on.**
 - Solenoid circuit problem.
- **No up shift, maximum line pressure.**
 - Possible bad ground, stuck valves or N/P switch failed.

Hydraulic control characteristics:

The converter clutch can be applied by the TCM after first gear is obtained. This is a fuel saving strategy.

Torque specs:

Mechatronic to case bolts: 6 Nm/53in lb.
Metal oil pan to case: 14 Nm/10ft lb.
Plastic oil pan to case: 10Nm/89in lb.
Pump bolts to case: 10Nm/89in lb.
Output shaft flange nut: 60Nm/44ft lb.
Turning torque of 6HP 19 converter friction plate: - 5-12 Nm/50-90in lb.

End Play/ Clutch clearance:

Rear unit end play, (flanged output) 0.15-0.35mm / .006”-.013”
Input shaft end-play: 0.2-0.4 mm/ .008”-.015”
Clutch clearance (refer to OE clutch travel specs.) and material is critical. These have fluid balanced clutch pistons. Clutch clearance should be checked with a 200 Nm. load placed on a piston return.

Fluid/ Fill:

The thermal element must open (88C, 190F) to purge the cooler, before verifying the fluid level! Complete fill requires 9.5 qt. / 9 liter. Service fill - approx. 4.2 qt. / 4 liter.
Preheat the transmission by running it through gear ranges. While in Park at an idle, with transmission at 35-40°C (104° F), remove the drain plug. At that temperature the fluid should drain as a small stream.
Ford 6R60- extension housing has an Allen head fill plug and /or the front corner of the case has a hex head fill plug. A dipstick lives within this plug.
Ford fluid: XT-6-QSP, Mercon SP. Shell M-1375.4
ZF Lifeguard fluid 1 liter: S671 090 0255- 20 liter: S671 090 253

COMMON PART NUMBERS	
FUNCTIONAL MANUALS- ZF 6HP 19-28	
BMW	#1068 766 701
Audi	#1068 766 704
Ford 6R60/80	PTB 601
REPAIR MANUALS	
6HP	#1071 766 701
6HP 19A	#1071 766 702
6HP 19X	#1071 751 702
OIL PAN SCREWS	
Plastic pan	#0736 101 486
Aluminum pan	#0736 010 347
Drain plug	#0501 318 960
Output flange locknut	#0501 321 759
Sealing ring for flange	#0734 310 418
Sealing sleeve/pass through connector	#0501 216 272
Solenoid foam strip	#1068 327 241
SOLENOID KITS	
6HP 19/26/32 (M shift) 1 black; 3 blue; 3 yellow	#1068 298 044
6HP 19/26/32 (M shift) 1 black; 1 blue; 5 yellow	#1068 298 045
6HP 19/26/32 (E shift) 2 black; 1 green; 3 blue; 3 yellow; MV	#1068 298 043
6HP 21/28 (E shift) 2 orange; 1 green; 2 blue; 3 yellow; MV	#1068 298 047
6HP 21/28 (M shift) 2 orange; 2 blue; 3 yellow	#1068 298 046
INDIVIDUAL SOLENOIDS	
EDS blue	#0501 213 959
EDS yellow	#0501 213 960
EDS black	#0501 319 037
SEPARATOR PLATES	
Contact the aftermarket sources. Supply the plate code. For Ford or ZF, supply the transmission code. Seven variations to date. 3 most common part numbers.	

TR-60SN/09D

Critical Wear Areas and Vacuum Test Locations TR-60SN Top Casting

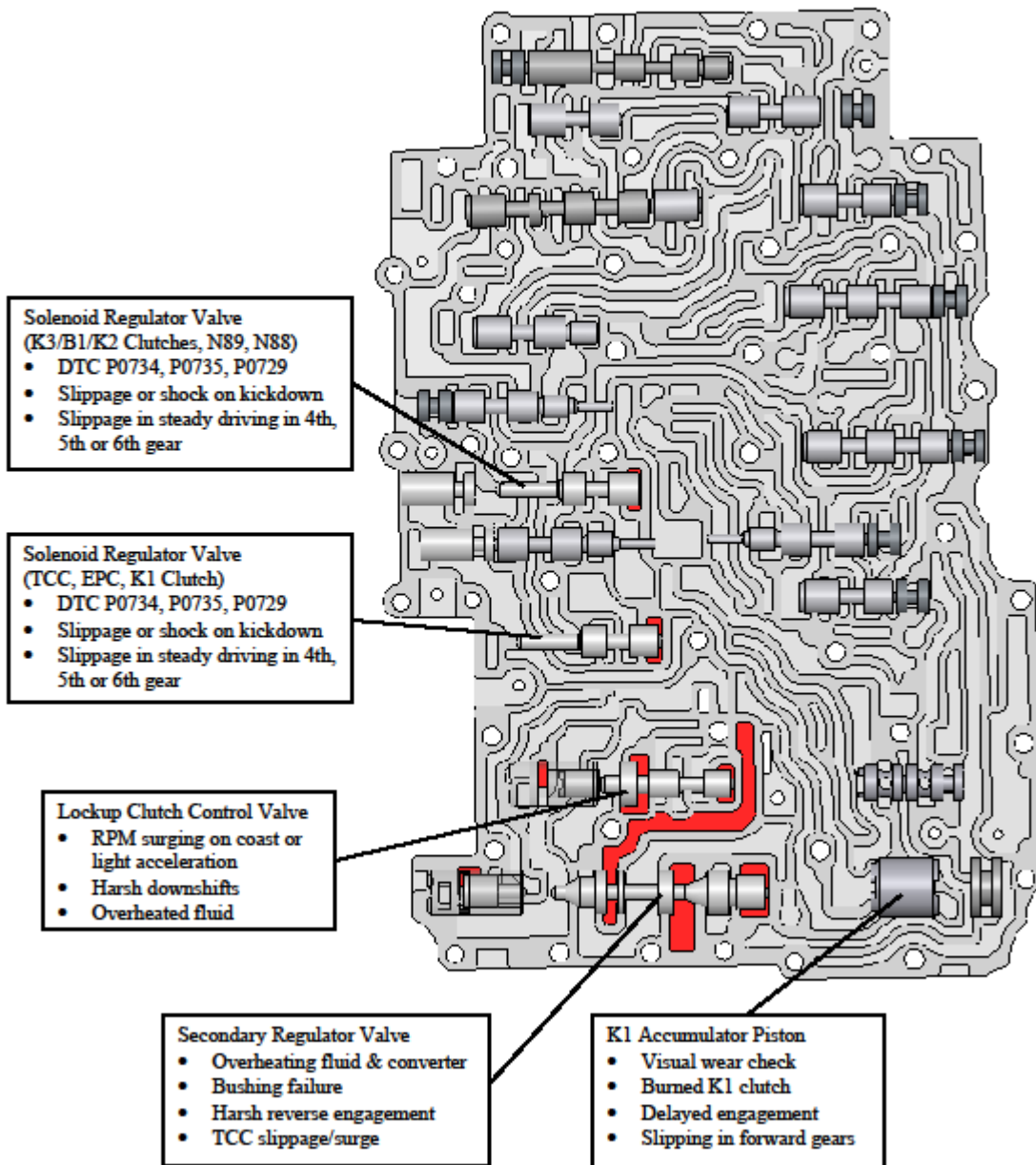

**Critical Wear Areas and Vacuum Test Locations
 TR-60SN Bottom Casting**

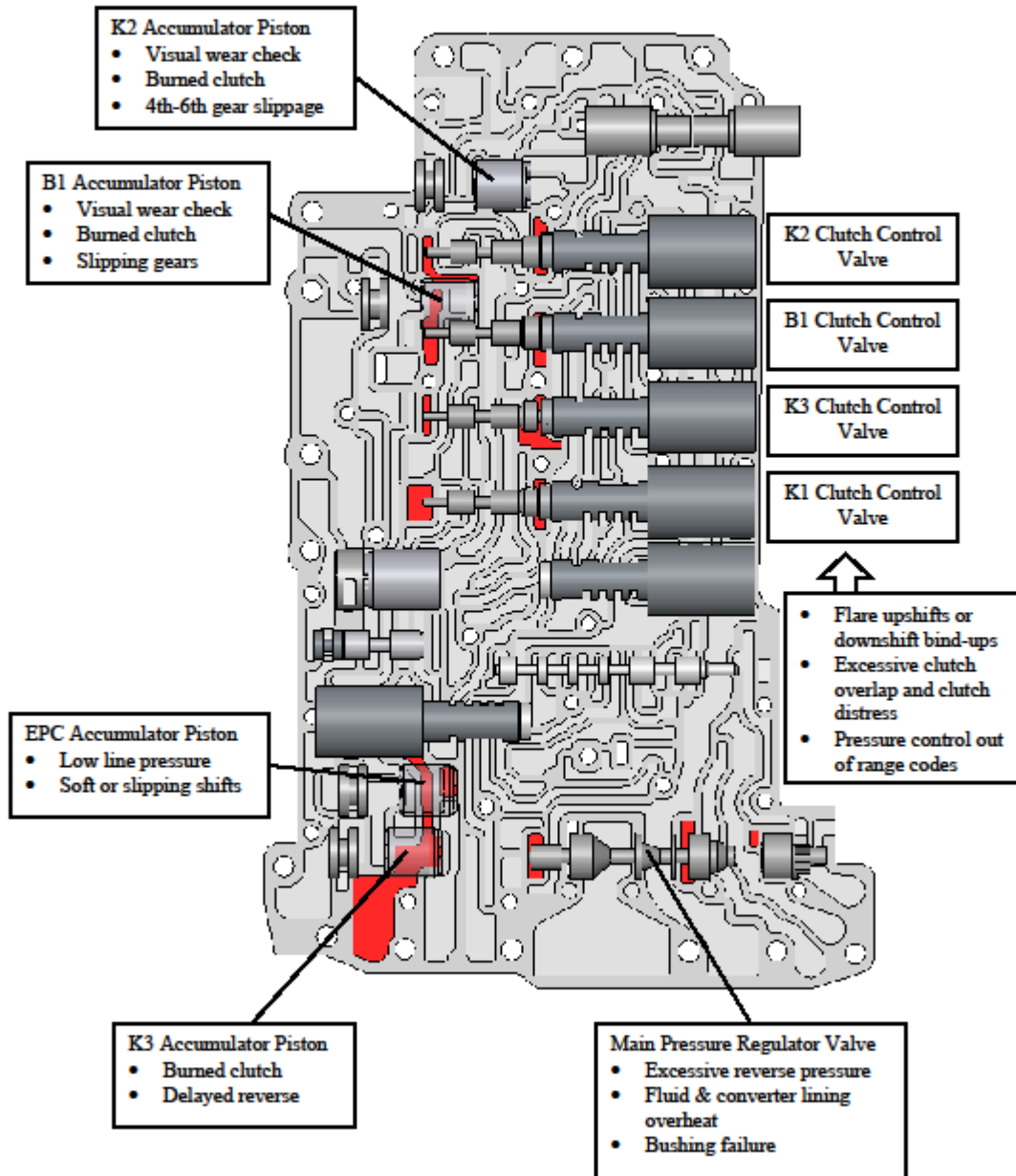

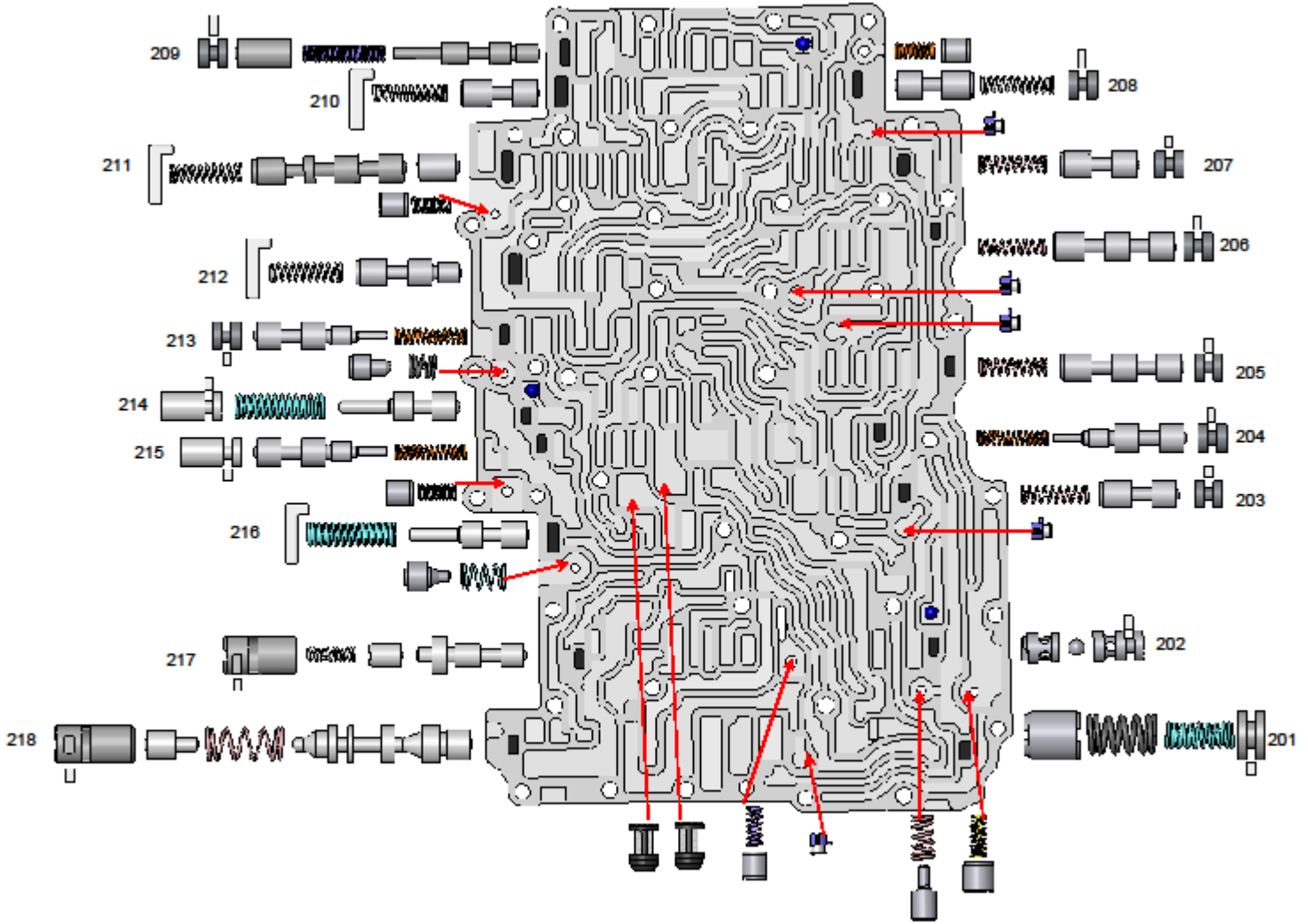

TR-60SN TOP CASTING

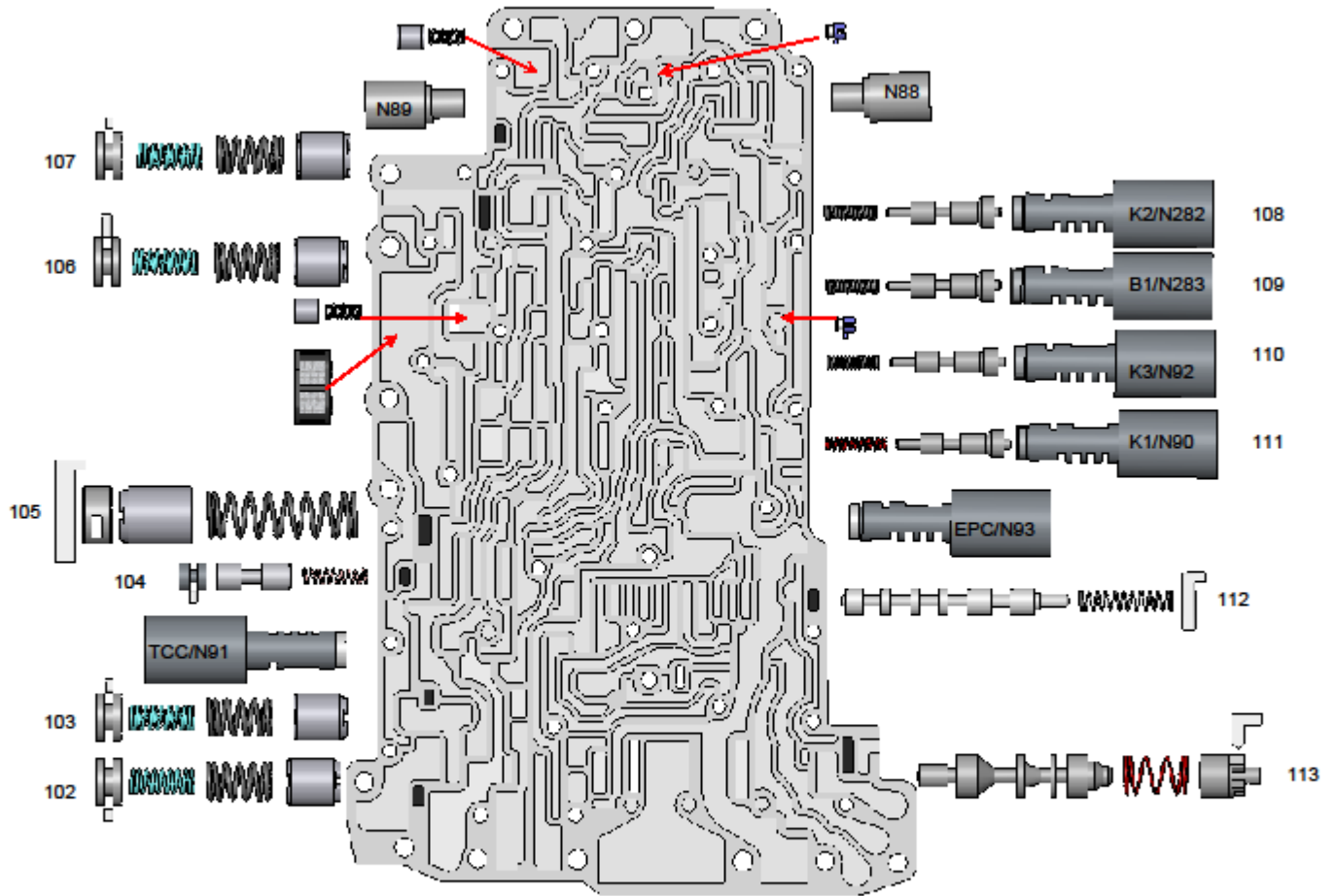

TR-60SN BOTTOM CASTING

TR-60SN Component Description and Location

Number	Location	Description
102	Bottom Casting	K3 Clutch Accumulator Piston
103	Bottom Casting	EPC Accumulator Piston
104	Bottom Casting	K1 Switch Valve
105	Bottom Casting	Forward Engagement Accumulator Piston
106	Bottom Casting	B1 Accumulator Piston
107	Bottom Casting	K2 Clutch Accumulator Piston
108	Bottom Casting	K2 Clutch Control Valve
109	Bottom Casting	B1 Clutch Control Valve
110	Bottom Casting	K3 Clutch Control Valve
111	Bottom Casting	K1 Clutch Control Valve
112	Bottom Casting	No. 1 Relay Valve
113	Bottom Casting	Main Pressure Regulator Valve Assembly
201	Top Casting	K1 Clutch Accumulator Piston
202	Top Casting	K3/B1 3-Way Check Valve
203	Top Casting	N283 (B1) Switch Valve
204	Top Casting	N90 (K1) Switch Valve
205	Top Casting	K3 Control Valve
206	Top Casting	B1 Control Valve
207	Top Casting	K2 Control Valve
208	Top Casting	B2 Control Valve
209	Top Casting	B2 Regulator Valve
210	Top Casting	Pressure Modifier Valve
211	Top Casting	No. 2 Relay Valve
212	Top Casting	B2 Port Control Valve
213	Top Casting	B1 Relay Valve
214	Top Casting	Solenoid Regulator Valve (K3, B1, K2, N89, N88)
215	Top Casting	K3 Relay Valve
216	Top Casting	Solenoid Regulator Valve (TCC, EPC, K1)
217	Top Casting	Lockup Clutch Control Valve and Plunger Valve Assembly
218	Top Casting	Secondary Regulator Valve and Plunger Valve Assembly

CLUTCH CONTROL VALVES

Complaint: Flare or Bumpy Shifts

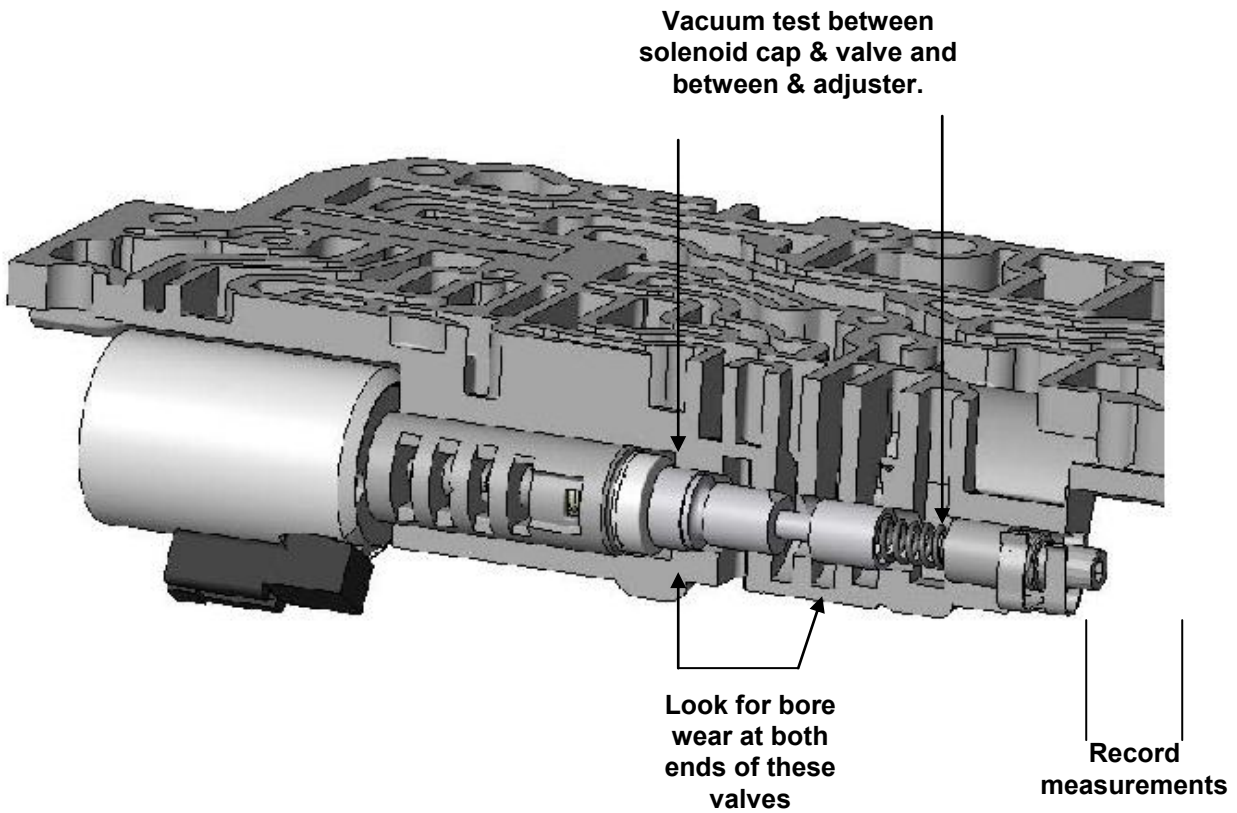

The solenoid OD, its end cap and the adjuster must seal oil circuits.

09D/09G Linear Solenoids

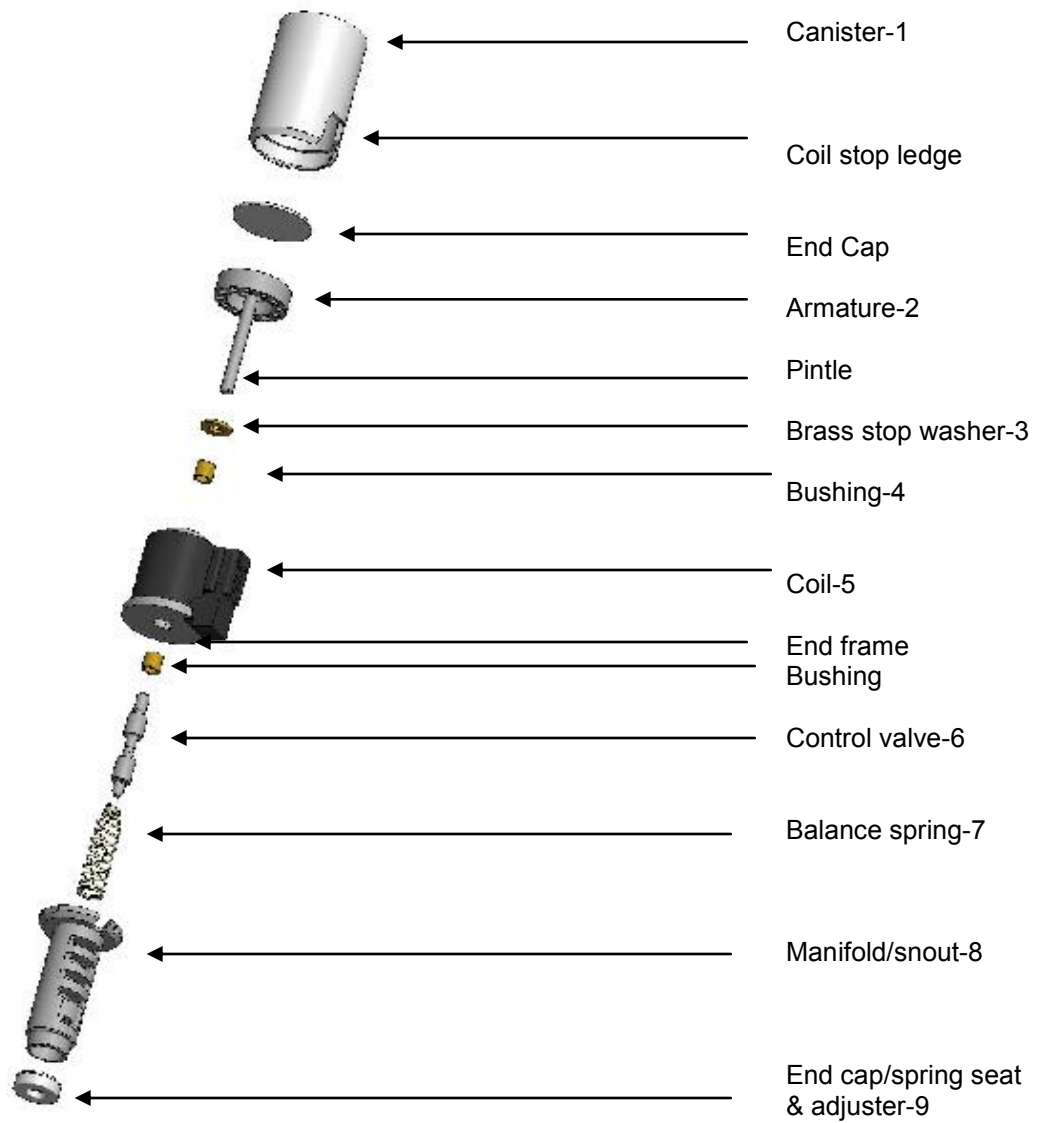

Aisin Linear Solenoids:

Sub-components:

#1-Canister :

The crimp secures the coil end frame to the manifold. A poor crimp, “will affect” output pressure. The assembly should not be able to rotate, as the weight of the coil and duty cycle will eventually cause the output pressure to change.

Removal of the end cap from the canister is an aftermarket form of service. If this process is used, the canister must be trimmed to the inner ledge of the canister id. If this is irregular, the distance of armature travel will be affected.

The OE end cap can trap contamination, slowing armature travel. Adding exhaust slots to this cap can reduce that build up. Once dis-assembled this canister should be demagnetized. Adding exhaust holes does not appear to have a negative affect on reaction time.

#2- Armature:

Look for cracks extending from the center where the pintle attaches. Polish the pintle shaft and verify it is not bent.

#3- Brass washers:

The washers are known to deform and become flat at the center. This will increase the travel of the armature.

#4- Coil bushings:

These bushings have an ID coating, which imbed with contamination. Aftermarket repairs often replace these bushings. If/ when doing so, they should be precision line bored. A twist drill will remove that coating, but often results in irregular surface finish.

To verify fit, place the armature in the coil and tip it end for end. The pintle should stroke under its own weight. Preference is to check this travel with a heated coil and prior to attaching the manifold.

#5- Coil:

Coils supply the magnetic field to move the armature. That field is captured within the canister and draws the armature toward the coil. Fluid pressure and the spring are the opposing force to that travel. Check the coil resistance and/or current at operating temperature.

#6- Control valve:

The control valve has a close tolerance to the manifold. Bore to valve tolerance can get a visual check by inserting the valve into the solenoid and checking it for wiggle or deflection.

#7- Balance spring:

The spring and valve force are toward the coil, moving the pintle. These springs can become fatigued. Insure the spring is positioned properly on the end cap, or it will coil bind and affect calibration.

#8- Manifold:

The manifolds are known to crack where they meet the canister. Bore wear is also common, which affects output pressure. The manifold must return flat to the coil and be held secure by the crimp.

The manifold with the installed valve can be vacuum tested. On the AW 55 series, vacuum is pulled at the small orifice. On the AW 6 series, the snout needs to be placed in a test fixture, such as a valve body casting.

#9- End cap, spring seat or adjuster:

This cap must fit tight onto the snout. It is a seal from clutch signal oil as well as a spring seat. The pin punch marks hold the cap onto the manifold. Once it is removed by prying it off, the press will be lost. It will require a 3-4 point repress. If a lathe is available, a groove can be cut into the end of the manifold to help retain the cap.

PRESSURE vs. AMPERAGE

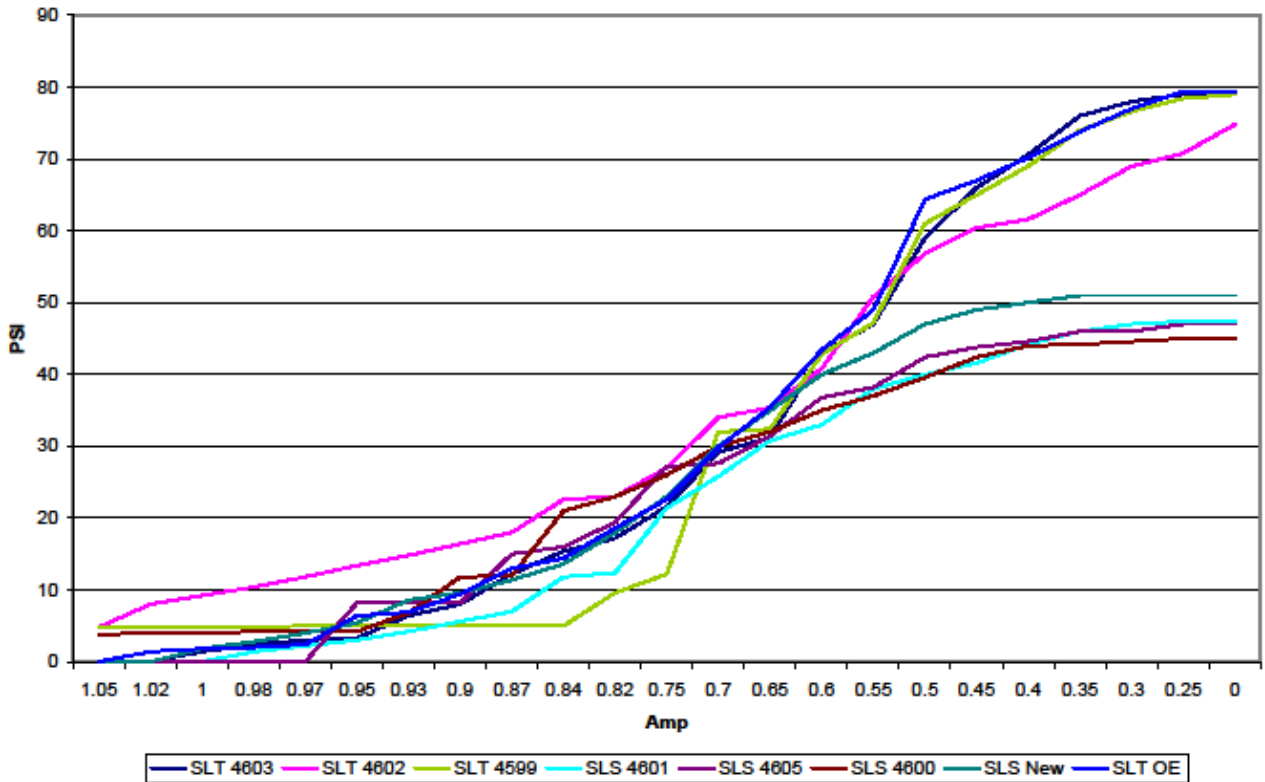

V. 3 TEST SOLENOIDS

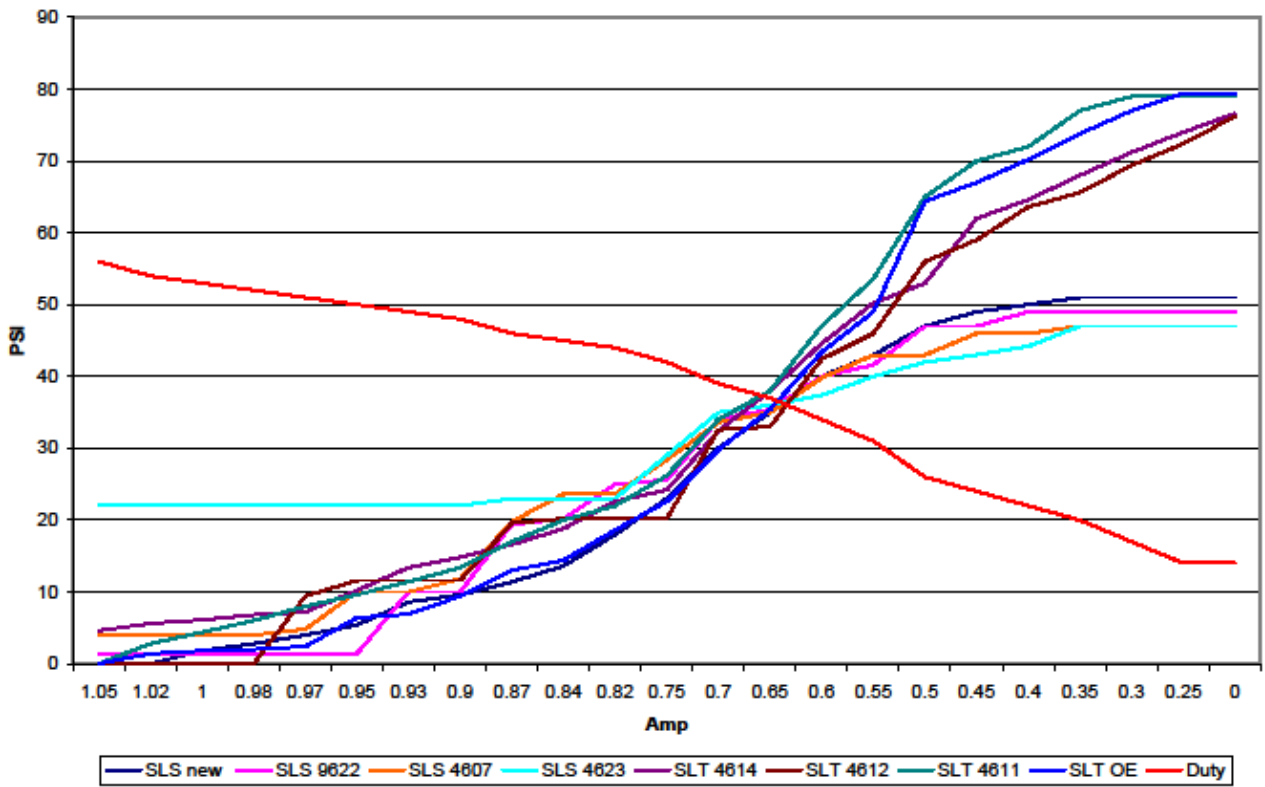

SLT

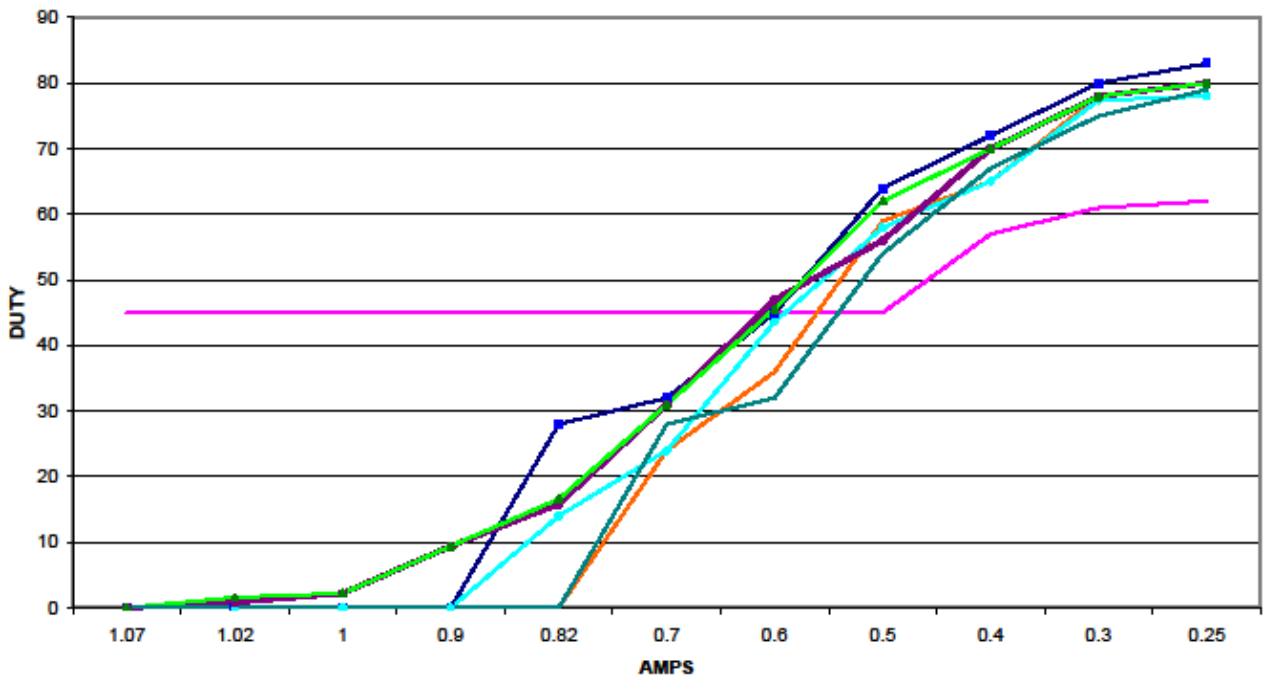

SOLENOID-POWERFLOW												AW6			
RANGE	SOLENOID										CLUTCH		BRAKE		O.W.C
	SSC SLC1	SSD SLC2	SSE SLC3	SSF SLB1	SSA S1	SSB S2	C-1	C-2	C-3	B-1 BAND	B-2 CLUTCH	F-1			
FORD/MOLVO/PSA	N92#5	N282#9	N90#3	N283#10	N88	N89	K-1	K-2	K-3	B-1 Clutch	B-2 CLUTCH	F-1			
V.W.															
P	X	X	X	X											
R	X	X		X				X		X					
N	X	X	X	X											
Neutral Control	X			X			X			X		X			
D		X	X				X				X	X			
S		X		X			X			X					
1ST		X	X				Z								
2ND		X	X				Z								
3RD		X		X			Cy		X						
4TH			X	X			Cy		X						
5TH	X			X			Cy		X						
6TH	X		X				Cy		X		X				
	SSC & SSE solenoids have residual clutch pressure feeding back to the opposing clutch control vale														
X = ON	= OFF	Z = ON DURING ENGINE BRAKING					Cy = CYCLED during up/down shift								
Solenoid for Clutch	C-1	C-2	C-3	B-1	TCC applies after 2-3 shift, modulated slip during up/down shift.										
RESISTANCE-OHMS	4.0-8.0	4.0-8.0	4.0-8.0	4.0-8.0	10-16	10-16	Linear solenoids operate at 300Hz.								
Solenoid Flow	N.O	N.O.	N.O.	N.O.	N.C	N.C	N91/TCC/SLU is N.C.; N93/EPC/SLT is N.O								

09D SOLENOID & WIRING

SOLENOID	RESISTANCE	INTERNAL WIRE COLOR	TERMINAL	VAG CODE	VAG ID
N88	15	White	1	00258	N88
N89	15	Black	2	00260	N89
N90	7.5	Yellow & Purple	3 & 4	00262	N90
N282	7.5	Red & Blue	5 & 6	00264	N91
N92	7.5	Lt. Blue & Yellow	7 & 8	00266	N92
N283	7.5	White & Black	9 & 10	00268	N93
N91	7.5	Lt. Green & Brown	11 & 12	00348	N282
N93	7.5	Green & Grey	13 & 14	00349	N283

Case Connector

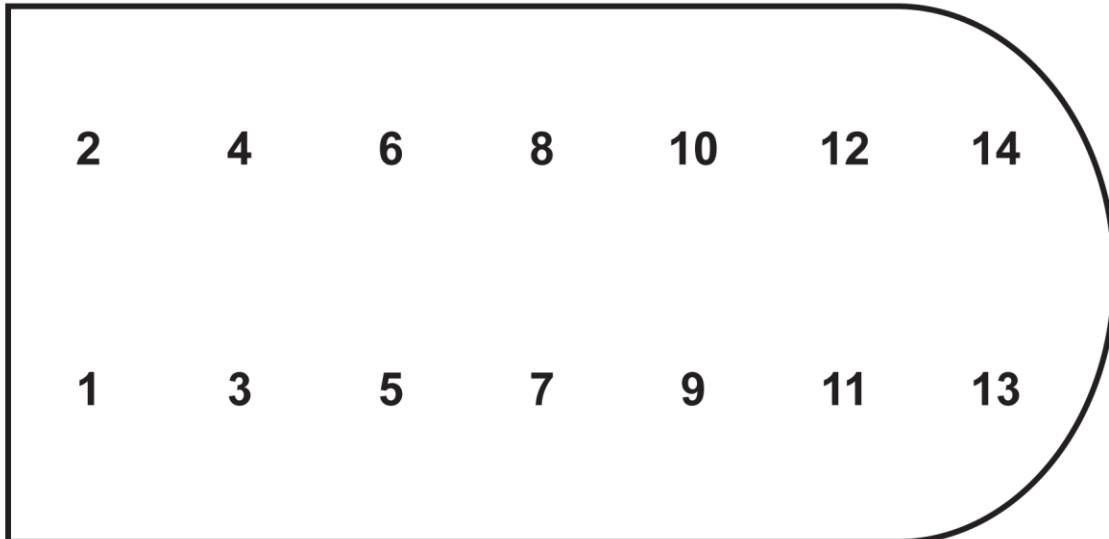

09D SENSORS & SOLENOIDS

G-193	CLUTCH PRESSURE SENSOR
G-194	CLUTCH PRESSURE SENSOR
G-182	INPUT SENSOR Reads turbine shaft at pump station
G-195	OUTPUT SENSOR Rear under valve body
G-93	TRANSMISSION TEMPERATURE (NTC-negative temperature coefficient, resistance drops as temperature rises) At 150°C TCC is closed At 170°C Engine torque is reduced Signal drop causes hard shifts. These sensors set into the line pressure circuit. Make sure the o ring seals well.
Solenoid valve 1	
N-88	ON-OFF SOLENOID N.C.- open allows 4 to 6th gear pulsed to interrupt shift on 5-6 If not open-loss of 4th, 5th & 6th.
Solenoid valve 2	
N-89	ON-OFF SOLENOID N.C.-open results in greater flow to converter release.
N-88 & 89	Opened simultaneously results in closing B-2 engine brake
Solenoid valve 3	
N-90	N.C. controls K-1 clutch apply & exhaust rate. Defective or cannot be actuated, cause firm 1-4
Solenoid valve 4	
N-91	No power results when converter is released
Solenoid valve 5	
N-92	N.C./Controls K-3 clutch apply & release. When defective, no power, can result in firm 3, 5 & Reverse
Solenoid valve 6	
N-93	N.C./EPC LINE RISE CONTROL No power results in maximum line pressure

Solenoid valve 9

N-282

N.C./Controls K-3 clutch apply & release.
 When defective, no power, can result in firm 4, 5 & 6

Solenoid valve 10

N-283

N.O. closes with increase current. Controls B-1 brake apply & exhaust.
 When defective, 2nd & 6th or 3-2 down may become firm.

NOTES:

Failsafe is 3rd- release

ATF—V-10 large converter (12 liters) 5 planet pinions; V-6 small converter (9.6 liters) 3 planet pinions.

Converter clutch strategy can start to apply clutch after 1000RPM

All rotating clutches are centrifugal compensated.

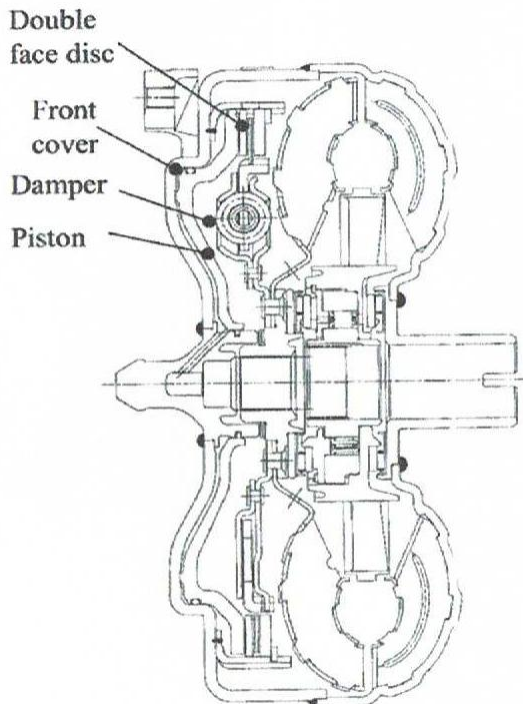
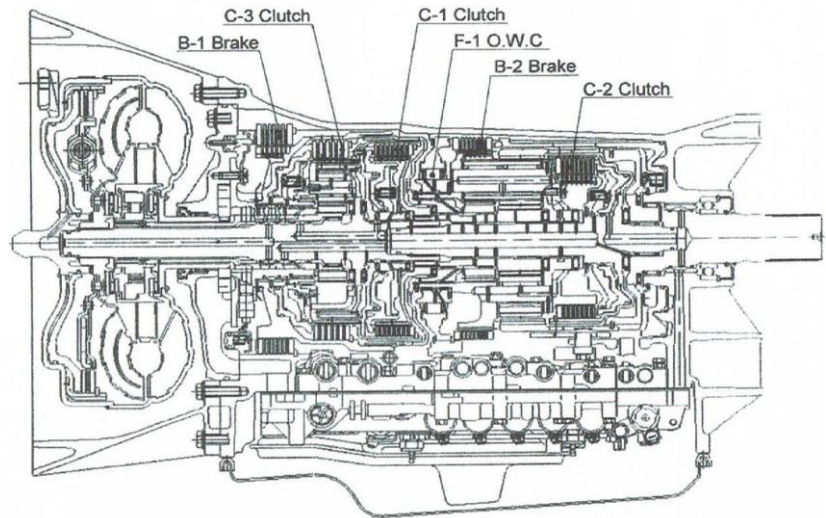

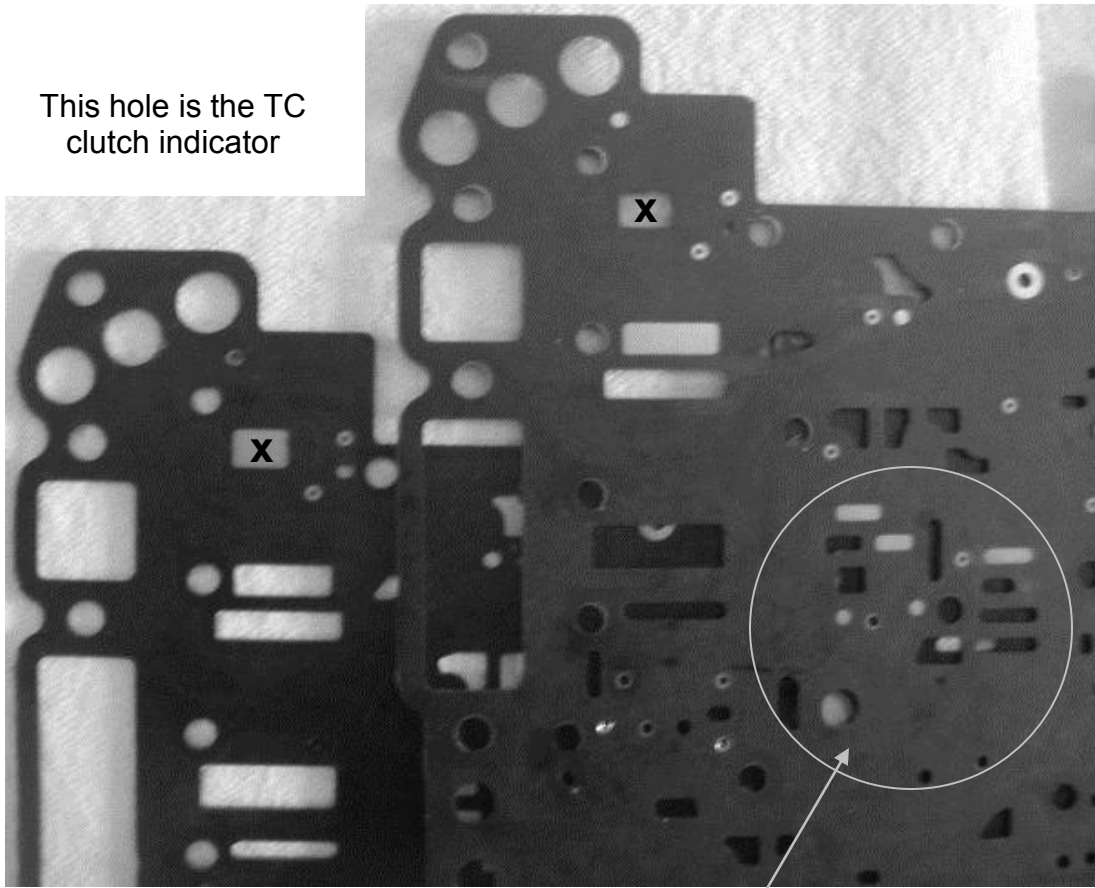

X Identification hole

NO Hole = 2 path converter
With Hole=3 path converter,
(TC piston in cover)

This area has multiple variations depending on converter. Pictured on top is a 2 path, B plate, with no hole at -X-.

09D LOWER VALVE BODY, VACUUM TEST LOCATIONS

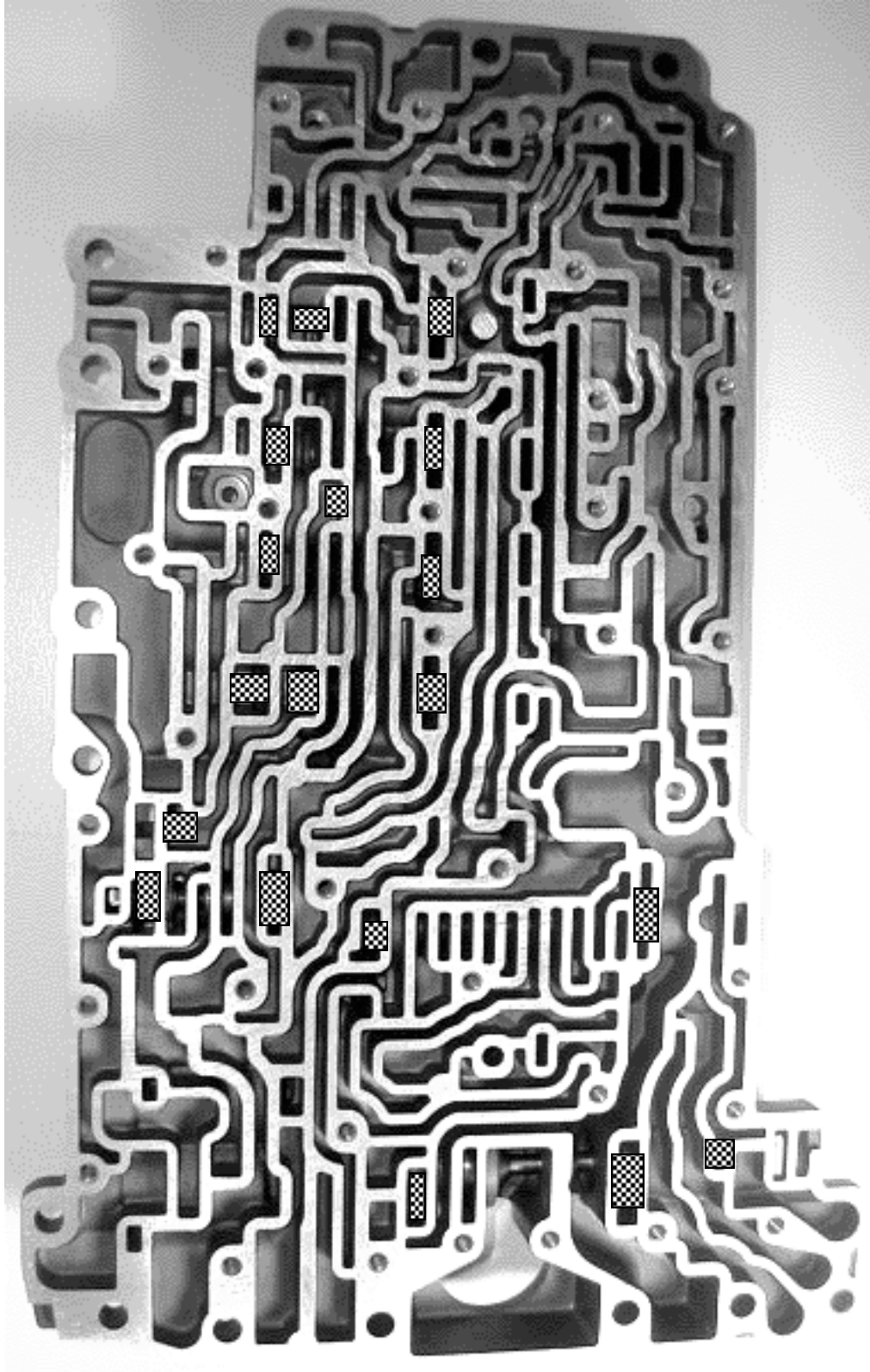

09D UPPER VALVE BODY, VACUUM TEST LOCATIONS

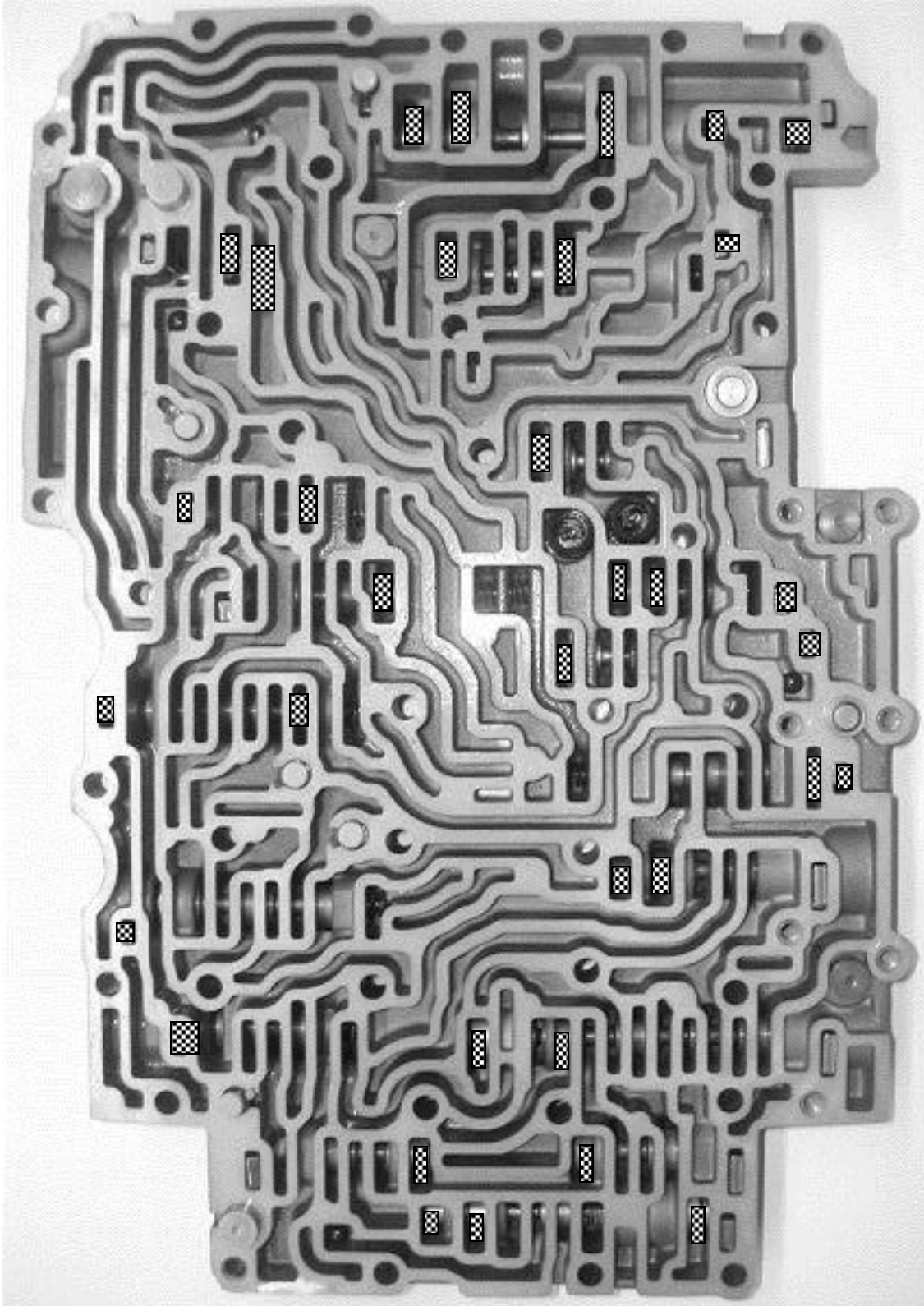

VACUUM TEST PROCEDURES

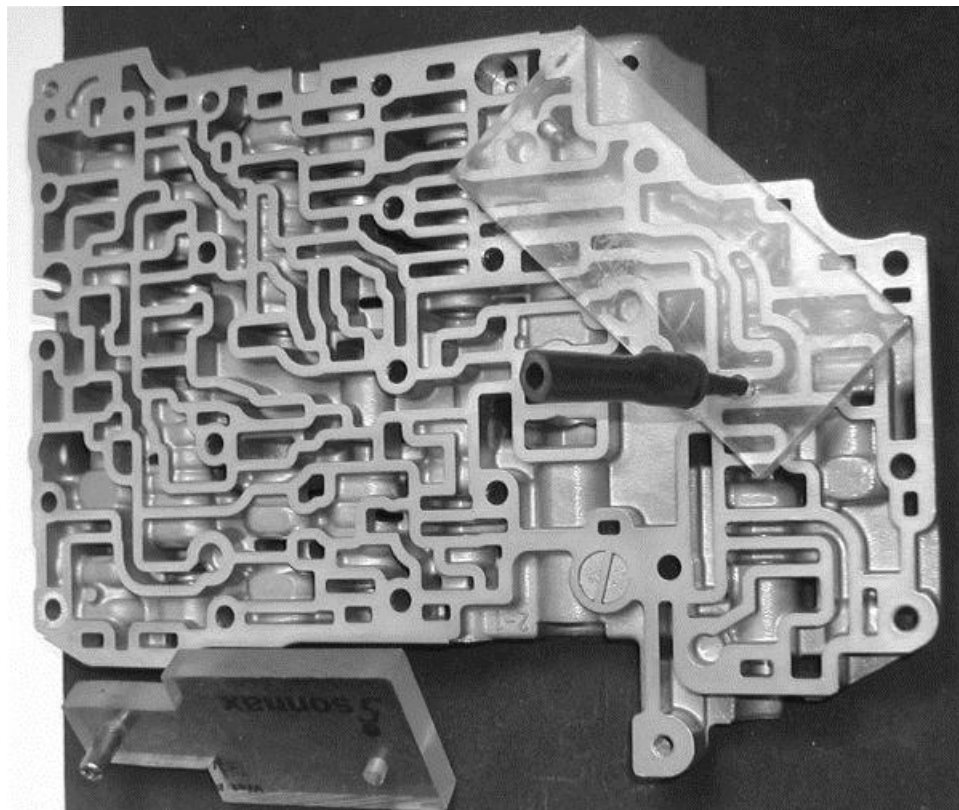

**FABRICATED VACUUM TEST STAND PART SOURCES,
 SET UP AND CALIBRATION**

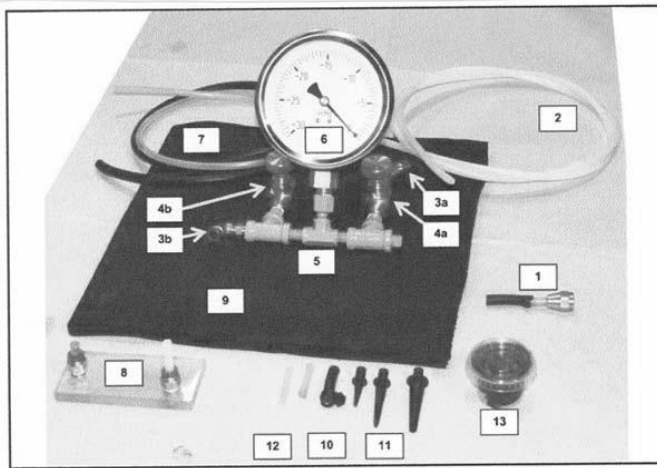

ITEM	DESCRIPTION		SOURCE	NUMBER
1	Adaptor to vacuum pump to tubing	¼" flare tubing nut	Hardware Store	
2	Tubing vacuum pump to test stand	Tubing ¼" O.D.	McMaster Carr	5548K74
3a/b	Fitting, 90° 1/8" npt (m) x ¼" tube (push connect)	Parker XW169PLN-4-2	McMaster Carr	51025K136
4a/b	Valve, precision adjustable	Generant 3000-1	MSC Supply	86495629
5	Manifold; (3) Tees 1/8" npt(f); (4) 1" long nipples 1/8" npt (m); (1) adaptor 1/8" npt (m) X ¼" pt (f)		Hardware Store	
6	Vacuum gauge (not liquid)	Wika 4271531	Industrial Automation	36100
7	Tubing/rubber vacuum hose, test stand to test plate		Hardware Store	
8	Sonnax WAT Test Plate 2 fittings 10-32 or 1/8" npt	Parker X68PLN-4-0	Sonnax Industries McMasters	SWAT 51025K324
9	Foam	11"x31"x3/8"	Goodson Supply	DVC-1131
10	Calibration orifice (drilled cup plug)			
11	Vacuum tips	Mityvac 822304	A&A Hydraulics	822304
12	Assembled vacuum tester		ATS	
www.mcmaster.com		www.mscdirect.com	www.goodson.com	www.gaugestore.com
www.hydraulicparts.com		atsdiagnostic.com		

Assembly:

Assemble as shown in photo. Tubing from the vacuum pump should be run to the test stand at fitting 3a. Tubing from the test stand fitting 3b should run to test plate, vacuum tips or calibration orifice.

Calibration:

The test stand should be calibrated before each use.

Use a .035" orifice (item #10) to calibrate your test stand. With the pump on, place this orificed tubing section on the test end of the tubing. Seal off the orificed tubing section with thumb and adjust the air bleed valve (4g) to 25" on the gauge. Adjust the air flow valve (4a) to read 5" on the gauge (6). Repeat.

The test stand is now calibrated for repeatable results. A perfect seal will be 25" on the gauge.

09G VALVE BODY ON THE AIR TEST PLATE

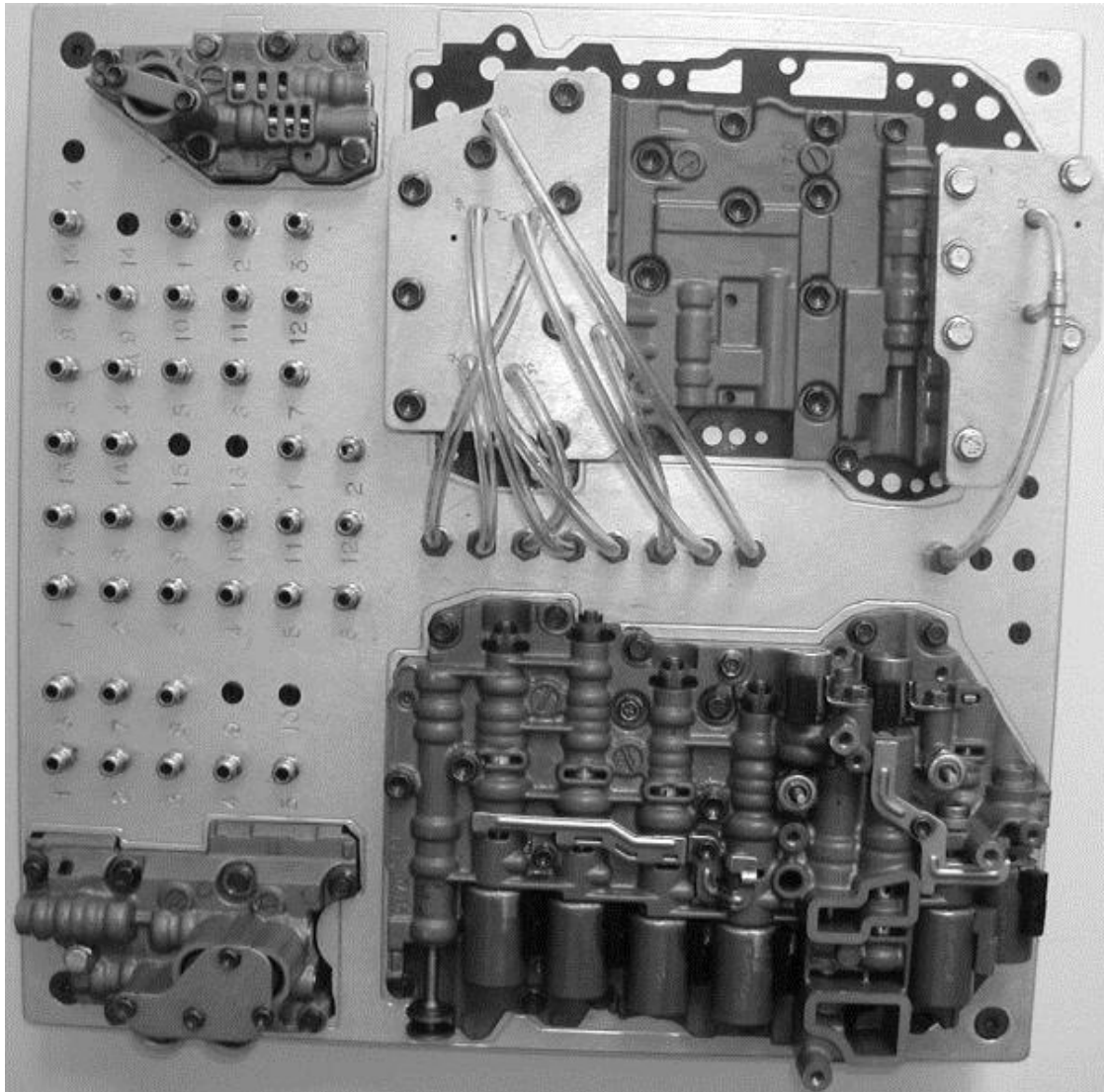

For more information contact atsdiagnostic.com

Test sheet examples on the next 3 pages.

TF-60SN/O9G

PSI		ACUAI		Complaint w/excess leak	Circuit/s Identification	Bore #	Repair #
Port #	Good						
				Lower solenoid body			
1	80			Delayed forward or reverse; low K-1 psi	Manual valve	8	15741-41
2	45			Delay reverse; loss or flare on 2-3; bump down shifts	K-3 clutch control	7	15741-08K
3	55			Flare 1-2 or 5-6; harsh 2-1 down	B-1 clutch control	6	15741-22K
4	65			Flare 3-4; harsh 4-3 down shift	K-2 clutch control	5	15741-05K
5	65			Delay in forward; 4-5 flare; 5-4 harsh	K-1 clutch control	4	15741-25K
6	50			High-low erratic line pressure	Pressure regulator balance	1	15741-01K
7	75			Poor line rise	Pressure regulator boost	1	15741-01K
8	40			Poor converter charge; TCC slip; lube distress	Secondary regulator	2	15741-11K
9	40			Erratic shift & solenoid feed psi	Solenoid modulator 2	3	15741-18K
10	5			TCC issues	SLU solenoid		Rostra
11	10			SLT- Line rise issues	SLT solenoid		Rostra
12	30			K-1 clutch control	K-1 solenoid		Rostra
13	30			K-2 clutch control	K-2 solenoid		Rostra
14	25			B-1 & K-3 clutch control	B-1 & K-3 solenoid		Rostra

Lower solenoid body: Pressure may increase if the bolts from the rear are installed. They are optional.
 Port 1- Manual valve can be tested in multiple positions. Suggest side pressure on the valve to identify bore wear.

Port 14- Due to 13 & 14 being tied together, both of these linear solenoids must be controlled. To isolate independently, move each to bore 12 and retest.

Port 10 to 14 test the solenoid. The snout to valve and the bore to snout clearance. Suggest you heat these to 85° c or 180°f prior to testing.

Row/Sonnax_062810

