

Drive Shaft and Axle

GENERAL	DS - 2
DRIVE SHAFT	DS - 7
FRONT AXLE	DS -16
REAR AXLE	DS -22

GENERAL

SPECIFICATIONS EFBCC3F0

Item		1.6L M/T	1.6L A/T	2.0L M/T	2.0L A/T	2.0DSL M/T	
Drive shaft	Joint type	Outer	BJ	BJ	BJ	BJ	
		Inner	UTJ-II	UTJ-II	UTJ-II	TJ	UTJ-II
	Maximum permissible	Outer	46° or more				
		Inner	23° or more				
Hub end play mm (in.)		0.008 (0.0003) or less					
Wheel bearing starting torque		1.8Nm (18kg-cm, 1.3 lb-ft) or less					

BJ : Birfield Joint

A/T : Automatic Transaxle

TJ : Tripod Joint

UTJ-II : U TYPE-II Tripod Joint

M/T : Manual Transaxle

TIGHTENING TORQUE

	Nm	kg-cm	lb-ft
Drive shaft lock nut	200 ~ 250	2000 ~ 2500	145 ~ 188
Knuckle to strut assembly nut	130 ~ 150	1300 ~ 1500	94 ~ 108
Lower arm ball joint to knuckle nut	60 ~ 72	600 ~ 720	43 ~ 52
Tie rod end to knuckle	16 ~ 34	160 ~ 340	12 ~ 25
Brake caliper to knuckle	69 ~ 85	690 ~ 850	50 ~ 61
Wheel nut	90 ~ 110	900 ~ 1100	65 ~ 80
Rear hub bearing flange nut	200 ~ 260	2000 ~ 2600	145 ~ 188
Rear brake to rear axle carrier mounting bolt	65 ~ 75	650 ~ 750	47 ~ 54
Rear strut to carrier nut	110 ~ 130	1100 ~ 1300	80 ~ 94
Trailing arm to rear axle carrier mounting nut	100 ~ 120	1000 ~ 1200	72 ~ 87
Rear suspension arm to rear axle carrier mounting nut	130 ~ 150	1300 ~ 1500	94 ~ 108
Brake disc to hub	5 ~ 6	50 ~ 60	3.6 ~ 4.3



CAUTION

Replace self-locking nuts with new ones after removal.

SPECIAL TOOLS ED6FA855

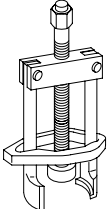
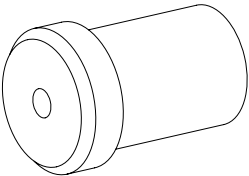
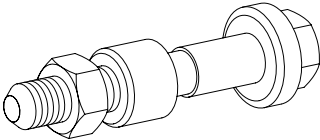
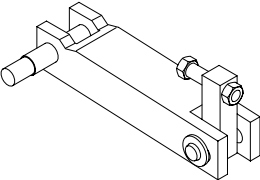
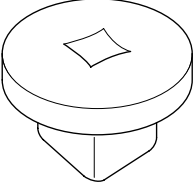
Tool (Number and Name)	Illustration	Use
09495-33000 Puller	 D9533000	Removal of wheel bearing inner race from a hub.
09495-33100 Center bearing remover and installer	 D9533100	<ol style="list-style-type: none">1. Removal of a wheel bearing from a knuckle. (use with 09517-29000)2. Installation of a hub to a knuckle.
09517-21500 Front hub remover and installer	 E1721500	<ol style="list-style-type: none">1. Removal of a front hub from a knuckle. (use with 09517-29000)2. Measurement of a front wheel bearing pre-load. (use with 09532-11600)
09517-29000 Knuckle arm bridge	 E1729000	<ol style="list-style-type: none">1. Removal of a front hub from a knuckle. (use with 09517-21500)2. Removal of a wheel bearing outer race from a knuckle. (use with 09495-33100)
09532-11600 Preload socket	 E3211600	Measurement of a front wheel bearing pre-load. (use with 09517-21500)

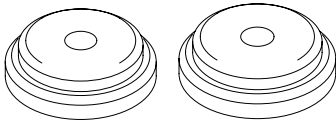
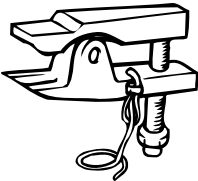
Tool (Number and Name)	Illustration	Use
09532-11500 Bearing outer race installer	 E3231200	Installation of a wheel bearing to knuckle.
09568-34000 Ball joint puller	 E6834000	Separation of a lower arm and a tie rod end ball joint.

TROUBLESHOOTING EAEA199D

It serves as a place to record information reported as well as data from the testing to be carried out.

GENERAL DIAGNOSTICS AND TESTS

To begin a successful diagnosis, fill out the questions.

To assist the service adviser and the technician, check the drive shaft condition with the questions listed below by filling them.

DRIVE SHAFT CONDITION :	Noise <input type="checkbox"/>	Vibration <input type="checkbox"/>
Balance Weights Missing/Other Visual Defects?	Yes / No	
Maximum Allowable Runout :	_____	
Actual Runout :	Front _____	Middle _____ Rear _____
Two-Piece Drive shaft Runout :	Front _____	Rear _____
Middle Support Bearing :	Loose <input type="checkbox"/>	Damaged <input type="checkbox"/> Worn <input type="checkbox"/> Others _____
Suspect Drive shaft Balanced ?	Yes / No	
Pinion Angle :	Engine Height :	Specification _____ Actual _____
	Pinion Angle :	Specification _____ Actual _____
Drive shaft Angle - Truck :	Specification _____	Actual _____

EIKE002A

Once the concern is narrowed down to a symptom/condition, proceed to condition and Symptom Categories below. Condition and Symptom Categories.

Operation Condition Vehicle is moving

Depends more one how the vehicle is operated

- Speed related
 - Related to vehicle speed

- Noise occurs at specific vehicle speed. A high pitch noise (whine). Go to troubleshooting.
- Loudness proportional to vehicle speed. Low frequency noise at high speeds, noise and loudness increase with speed. Go to Troubleshooting.

- 2. Acceleration
 - Light/moderate acceleration
 - a. Driveline shudder. Go to Troubleshooting.
- 3. Cruising speeds
 - Driveline vibration. Go to Troubleshooting.

Symptom	Cause	Remedy
Hub howling or whine - Hub or transfer case	Axle lubricant low	Check the lubricant level. Fill the axle to specification
	Damaged or worn wheel bearings or axle bearings	Check for abnormal wheel bearing play or roughness. Refer to wheel Bearing Check in this section. Adjust or Install new wheel bearings as necessary.
Driveline clunk - loud clunk when shifting from reverse to drive	Excessive backlash in the axle or transmission	Carry out a total backlash check
	Loosen suspension components	Inspect the suspension for damage or wear.Repair or Install new components as necessary.
	Broken powertrain mounts	Inspect the powertrain mounts. Install new mounts as necessary.
	Idle speed too high	Check for the correct idle speed
Driveline clunk-occurs as the vehicle starts to move forward following a stop	Worn drive shaft joints with excessive play	Inspect the joints for a worn condition. Install a new driveshaft as necessary.
Driveline clunk-occurs during acceleration or from cruise to coast/deceleration	Damaged or worn tripod joints	Inspect the joint and boot. Repair or Install a new joint as necessary.
Quirer-noise from the rear hub, occurs when driving on rugged roads	Cap seperation from the hub bearing	Remove the rear hub check the hub bearing cap. Install a new cap if necessary.
Clicking, popping or grinding-occurs while vehicle is turning	Inadequate or contaminated lubrication in the joints	Check the joint boots and joints for wear or damage. Repair or Install new components as necessary.
	Another component contacting the drive shaft	Check the drive shafts and around the drive shafts. Repair as necessary.
	Brake components	Inspect the front brakes for wear or damage. Repair as necessary.
	Suspension components	Inspect the lower arm ball joints for wear or damage. Repair as necessary.
	Damaged or worn wheel bearings	Check for abnormal wheel bearing play or roughness. Refer to wheel bearing check in this section. Adjust or Install new wheel bearings as necessary.
Clicking or snapping-occurs when accelerating around a corner	Damaged or worn birfield joints	Inspect the Birfield joints and boots. Repair or Install a new joint as necessary.

Symptom	Cause	Remedy
Buzz-buzzing noise is the same at cruise or coast/deceleration	Damaged or worn tires	Check for abnormal tire wear or damage. Install a new tire as necessary.
Driveline shudder-occurs during acceleration from a slow speed or stop	Rear axle assembly mispositioned	Check the axle mounts and the rear suspension for damage or wear. Repair as necessary.
	Loose rear axle bolts	Inspect the bolts. Tighten the bolt nuts to specification.
	Damaged or worn front suspension components	Check for a loose stabilizerbar, damaged or loose strut/strut bushings or loose or worn ball joints. Inspect the steering linkage for wear or damage. Repair or Install new components as necessary.
	Binding the drive shaft joint	Inspect the drive shaft joint for worn, or damaged condition. Install a new drive shaft assembly as necessary. Repair as necessary.
	Loose rear axle bolts	Inspect the bolts. Tighten the bolts to specification.
Driveline vibration-occurs at cruising speeds	Binding or damaged drive shaft joint	Inspect the drive shaft joint for wear or damage. Install a new drive shaft assembly as necessary.
	Incorrect lateral and radial tire/wheel runout	Inspect the tire and wheels. Measure tire runouts. Repair or Install new components as necessary.
	Incorrectly seated joint in the front wheel hub	Check the Birfield joint for correct seating into the hub. Repair as necessary.

DRIVE SHAFT

FRONT DRIVE SHAFT ASSEMBLY

COMPONENTS ECC28200

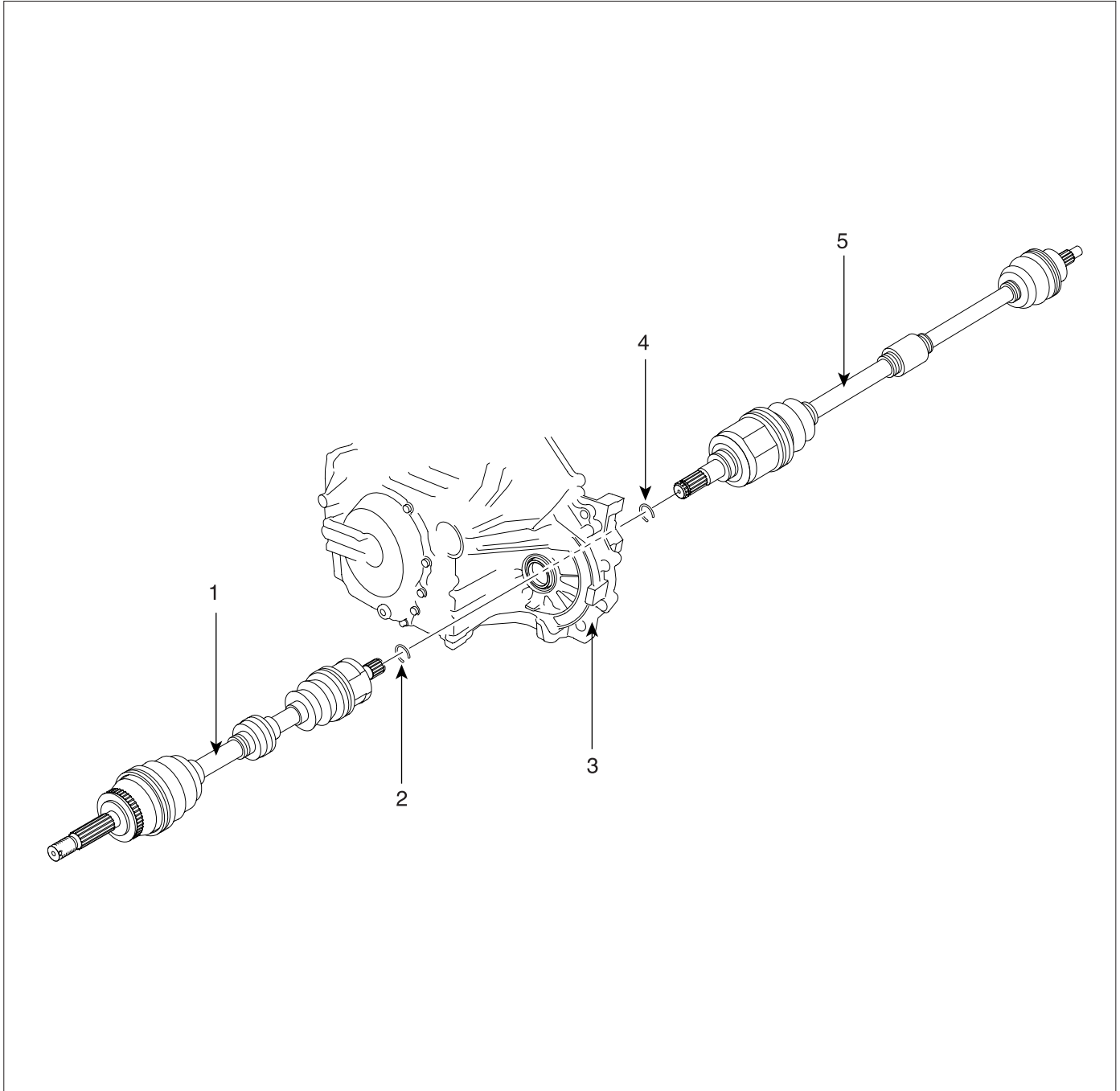

- 1. Driver shaft (LH)
- 2. Clip
- 3. Transaxle

- 4. Clip
- 5. Driver shaft (RH)

BIGE001H

REMOVAL EC68B33A

1. Loosen the wheel nuts slightly.
2. Raise the front of the vehicle and support it with safety stands in a proper location.
3. Remove the front wheel and tire.
4. Remove the drain plug(A). Drain the transaxle oil.
 - a. Lay a bottle keeping the gear oil under transaxle.
 - b. Remove drain plug(A) and washer(B) in the lower part of transaxle(C).

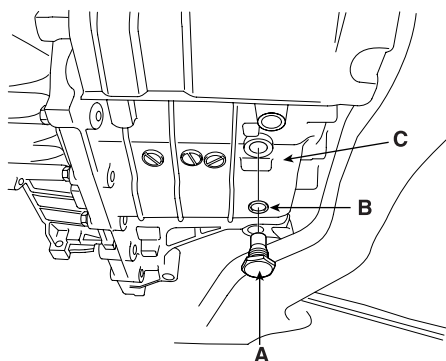

BIGE001A

5. Remove the split pin(A), the lock nut(B) and the washer(C) from the front hub(D) under applying the brake.

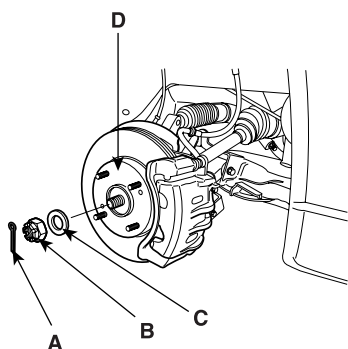

BIGE001B

6. Disconnect the tie rod end ball joint(A) from the knuckle(B) using the Special Tool (09568-34000) after removing the split pin and lock nut.

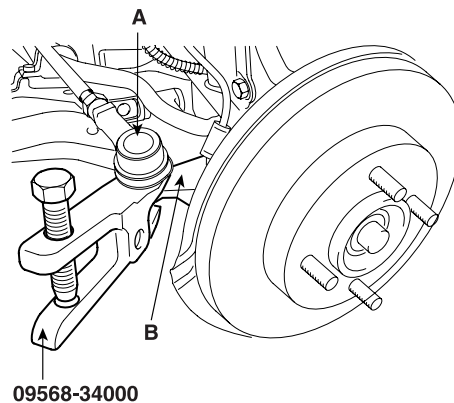

AIGE001B

7. Remove the wheel speed sensor(A) from the knuckle(B).

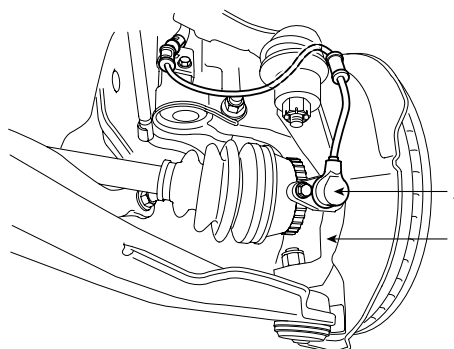

BIGE001D

8. Disconnect the strut upper mounting bolts(A).

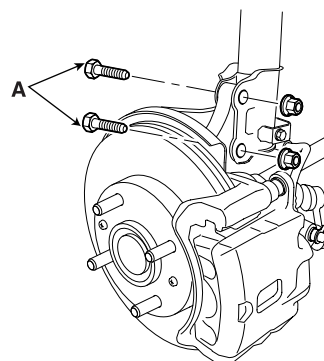

BIGE001E

9. Using a plastic hammer(A), disconnect the drive shaft(B) from the axle hub(C).

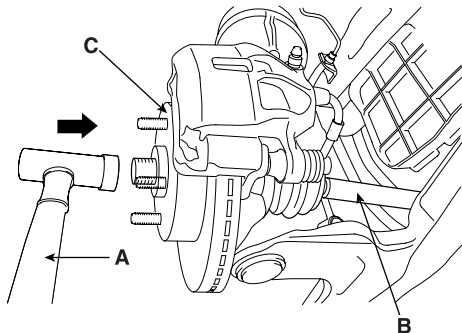

BIGE001F

10. Push the axle hub(C) outward and separate the drive shaft(B) from the axle hub(C).
11. Insert a pry bar(A) between the transaxle case(B) and joint case(C), and separate the drive shaft from the transaxle case(B).

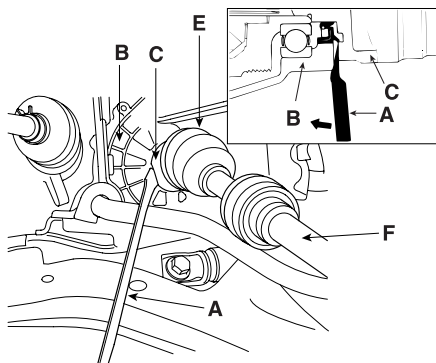

BIGE001G

12. Pull out the drive shaft(F) from the transaxle case(B).

CAUTION

- Plug the hole of the transaxle case with the oil seal cap to prevent contamination.
- Support the drive shaft properly.
- Replace the retainer ring whenever the drive shaft is removed from the transaxle case.

INSPECTION EFB2756C

1. Check the drive shaft boots for damage and deterioration.
2. Check the ball joints for wear and damage.
3. Check the splines for wear and damage.
4. Check the dynamic damper for cracks and wear.

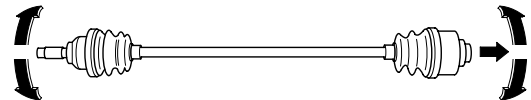

BIGE002A

CAUTION

- Use a pry bar(A) being careful not to damage the transaxle and joint.
- Do not insert the pry bar(A) too deep, as this may cause damage to the oil seal. [max. depth : 7mm (0.28 in.)]
- Do not pull the drive shaft by excessive force it may cause components inside the BJ or TJ joint(C) kit to dislodge resulting in a torn boot(E) or a damaged bearing.

DS -10

DRIVE SHAFT AND AXLE

INSTALLATION E1B2D43B

1. Apply gear oil on the drive shaft splines(A) and the contacting surface of differential case oil seal(B).
2. Before installing the drive shaft(C), set the opening side of the clip(D) facing downward.

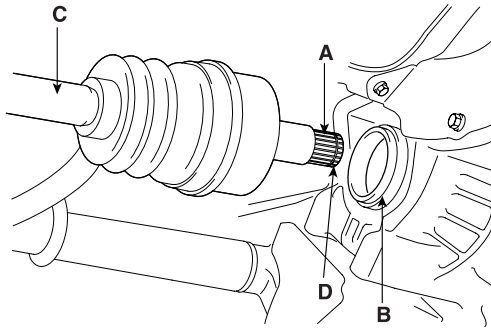

BIGE003A

3. After installation, check that the drive shaft cannot be removed by hand.
4. Install the drive shaft into the knuckle.



CAUTION

Be careful not to damage the boot.

5. Install the knuckle in the strut assembly with the tightening torque, 130~150 Nm (1300~1500 kg-cm, 94~108 lb-ft).
6. Install the wheel speed sensor in the knuckle with the tightening torque 8~10Nm (80~100kg-cm, 5.8~7.2 lb-ft).
7. Install the tie rod end ball joint in the knuckle with the tightening torque 16~34 Nm (160~340 kg-cm, 12~25 lb-ft)

8. After installing the washer(B) with convex surface outward, install the lock nut(A) and the split pin(C).

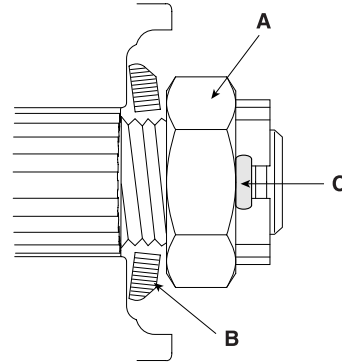

BIGE003B

9. Install the wheel and tire.

FRONT DRIVE SHAFT

COMPONENTS E7621EDA

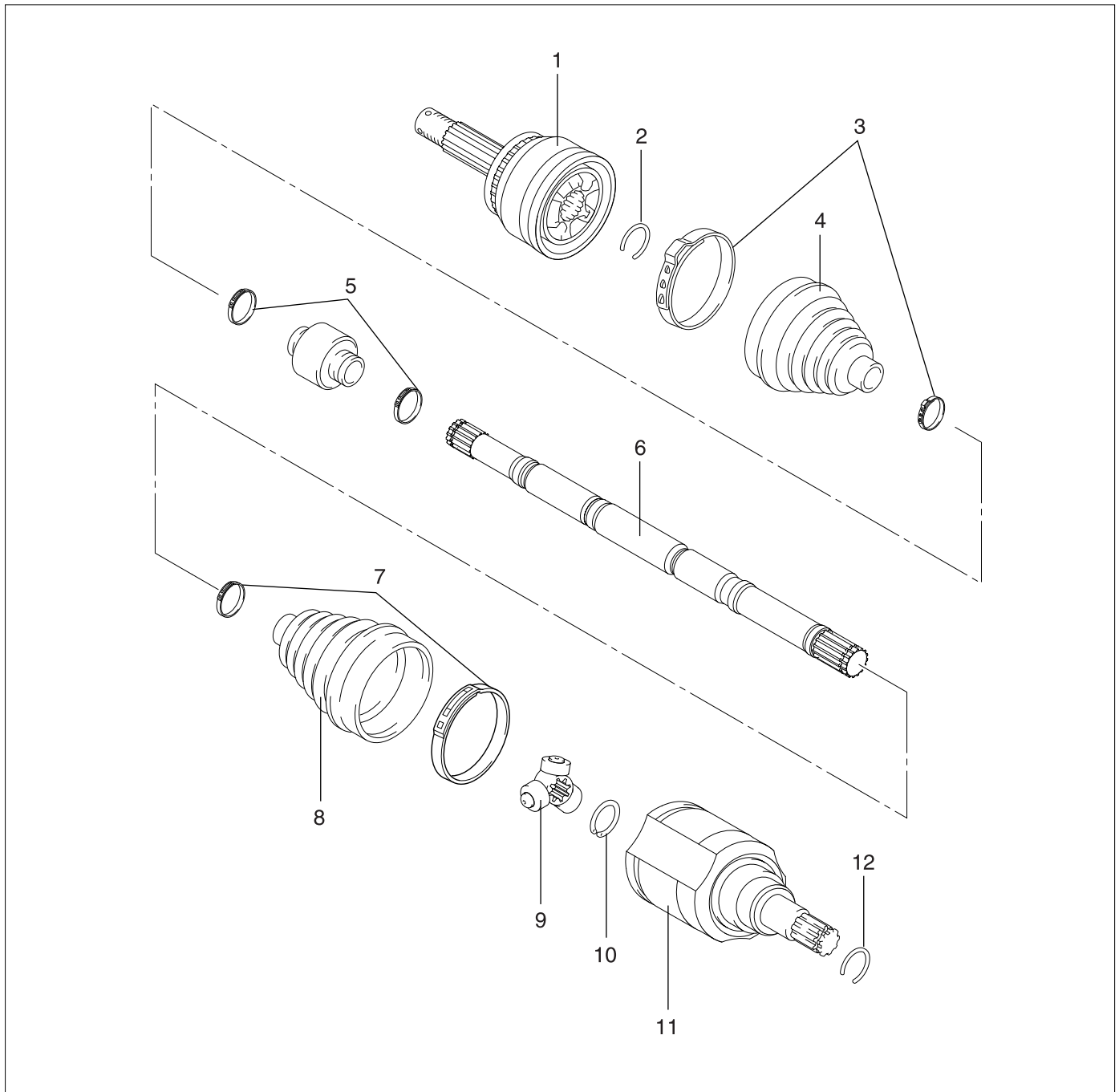

- 1. BJ assembly
- 2. Clip
- 3. BJ boot bands
- 4. BJ boot
- 5. Dynamic damper bands
- 6. Shaft

- 7. TJ boot bands
- 8. TJ boot
- 9. Spider assembly
- 10. Clip
- 11. TJ case
- 12. Clip

DISASSEMBLY EFC6A6D30

 **NOTE**

- Do not disassemble the BJ assembly.
- Special grease must be applied to the drive shaft joint. Do not substitute with another type of grease.
- The boot band should be replaced with a new one.

1. Remove the clip(B) from drive shaft splines(A) of the transaxle side TJ case(C).

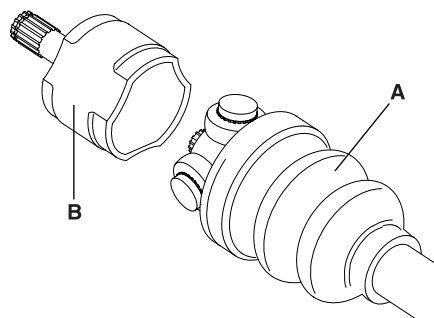

AIGE004B

 **CAUTION**

- Be careful not to damage the boot.
- Make alignment marks on spider roller assembly(A), TJ case(B) and shaft splines(C) to aid reassembly.

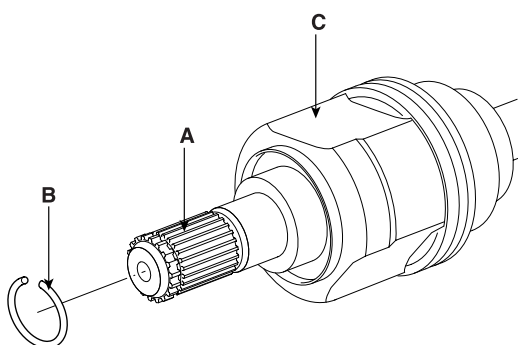

BIGE005A

2. Remove both boot bands from the transaxle side TJ case.

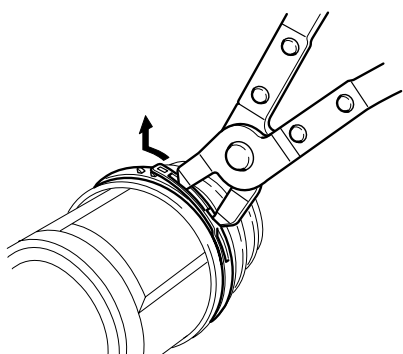

AIGE004A

3. Pull out the boot from the transaxle side joint(TJ).
4. When separating the joint and boot(A), remove the grease from the TJ case(B).

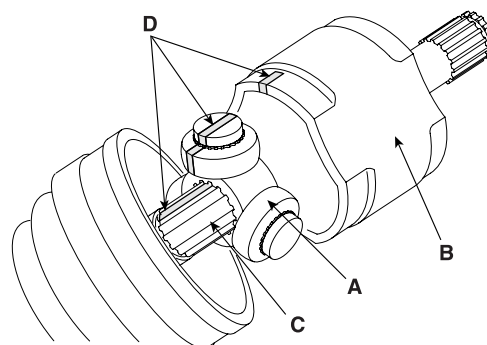

BIGE005D

5. Using a plier or flat-tipped (-) screwdriver, remove the snap ring(A).

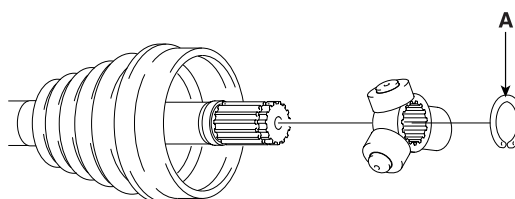

BIGE005E

6. Remove the spider assembly(B) from drive shaft(A) by using the Special Tool(09495-33000).

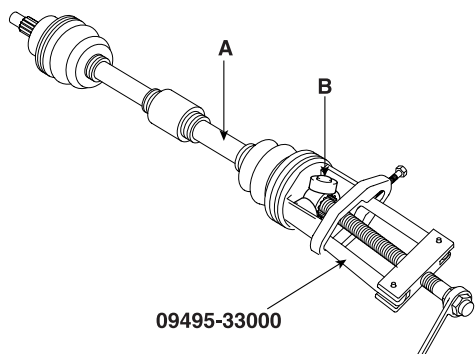

BIGE005F

9. Remove both side of bands(B,C) of the dynamic damper(A).

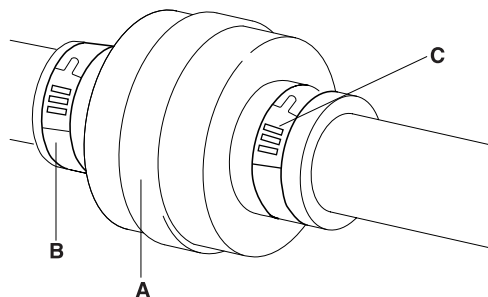

AIGE004C

7. Clean the spider assembly.
8. Remove the boot(A), of the transaxle side joint(TJ).

CAUTION

Wrap tape(B) around the driveshaft splines(C) to protect the boot(A).

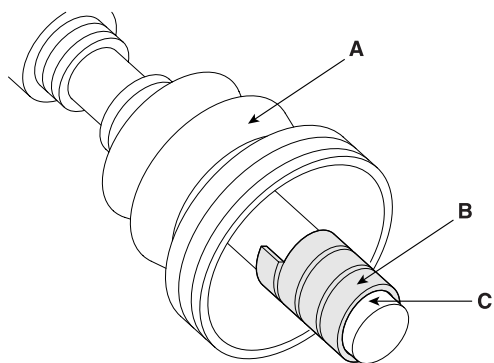

BIGE005G

10. Fix the drive shaft(A) with a vice(B) as illustrated.

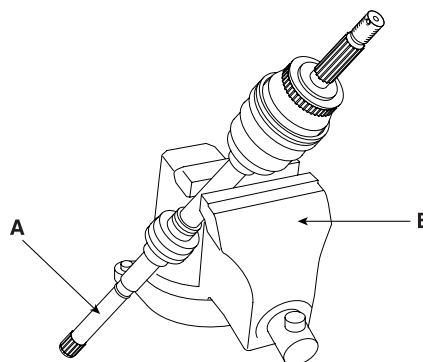

BIGE005I

11. Apply soap powder on the shaft to prevent being damaged between the shaft spline and the dynamic damper when the dynamic damper is removed.
12. Separate dynamic damper(A) from the shaft(B) carefully.

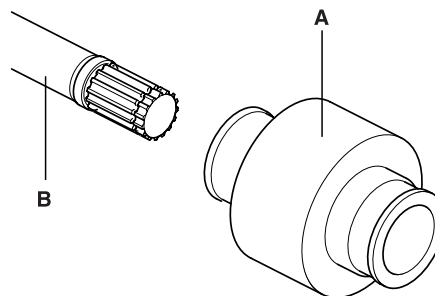

AIGE004D

DS -14

DRIVE SHAFT AND AXLE

13. Remove both bands on the side of wheel.

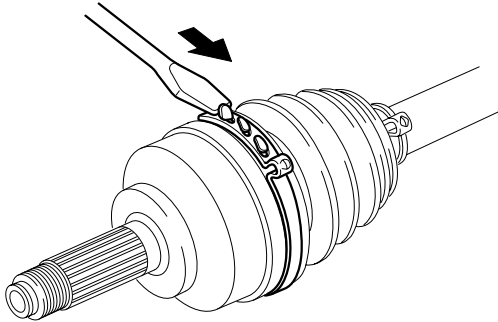

AIGE004E

14. Pull out the joint(BJ) boot on the side of wheel into the transaxle direction.
Be carefull not to damage the boot.

INSPECTION

E9E0EE65

1. Check the drive shaft spline for wear or damage.
2. Check that there is no water or foreign material in the BJ.
3. Check the spider assembly for roller rotation, wear or corrosion.
4. Check the groove inside the TJ case for wear or corrosion.
5. Check the dynamic damper for damage or cracks.

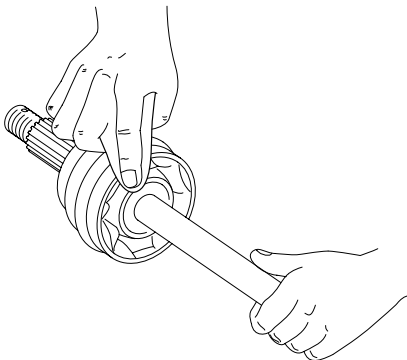

EIKD025B

REASSEMBLY

EE723D4C

1. Wrap tape around the drive shaft splines (TJ side) to prevent damage to the boots.
2. Apply grease to the joint(BJ) boot on the side of wheel and install the boots.
3. Install the bands to both boots.

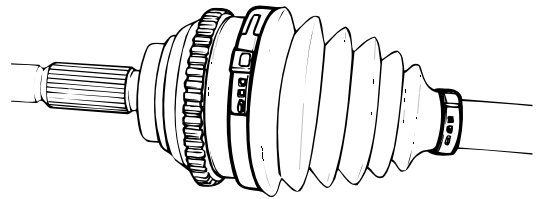

AIGE005A

4. Using clamp, secure the boot bands.

Clearance(A) : 2.0 mm (0.079 in.) or less

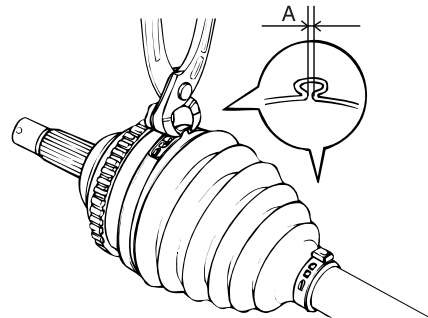

AIGE005B

- To install the dynamic damper, keep the BJ shaft in a straight line and secure the dynamic damper with the dynamic damper bands.

STANDARD VALUE

Model	LH (mm(in.))	RH (mm(in.))
1.6L M/T	245.3 $^{+2}_0$ (9.65 $^{+0.08}_0$)	427 $^{+2}_0$ (16.81 $^{+0.08}_0$)
1.6L A/T	245.3 $^{+2}_0$ (9.65 $^{+0.08}_0$)	427 $^{+2}_0$ (16.81 $^{+0.08}_0$)
2.0L M/T	246.3 $^{+2}_0$ (9.70 $^{+0.08}_0$)	428.5 $^{+2}_0$ (16.87 $^{+0.08}_0$)
2.0L A/T	244.2 $^{+2}_0$ (9.61 $^{+0.08}_0$)	428.5 $^{+2}_0$ (16.87 $^{+0.08}_0$)
2.0DSL M/T	247.9 $^{+2}_0$ (9.76 $^{+0.08}_0$)	415.5 $^{+2}_0$ (16.36 $^{+0.08}_0$)

LIGE005B

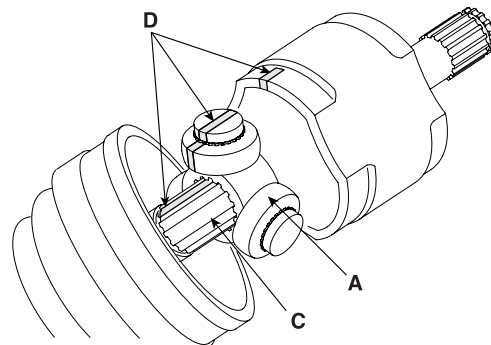

BIGE007E

- Add the specified grease to the joint(TJ) boot as much as wiped away at inspection.
- Install the boots.
- To control the air in the TJ boot, keep the specified distance between the boot bands when they are tightened.

STANDARD VALUE[A]

Model	LH (mm(in.))	RH (mm(in.))
1.6L M/T	515.5 ± 2 (20.29 ± 0.08)	800.9 ± 2 (31.53 ± 0.08)
1.6L A/T	516.0 ± 2 (20.31 ± 0.08)	801.0 ± 2 (31.53 ± 0.08)
2.0L M/T	516.4 ± 2 (20.33 ± 0.08)	801.3 ± 2 (31.55 ± 0.08)
2.0L A/T	513.4 ± 2 (20.21 ± 0.08)	802.1 ± 2 (31.58 ± 0.08)
2.0DSL A/T	514.3 ± 2 (20.25 ± 0.08)	802.0 ± 2 (31.57 ± 0.08)

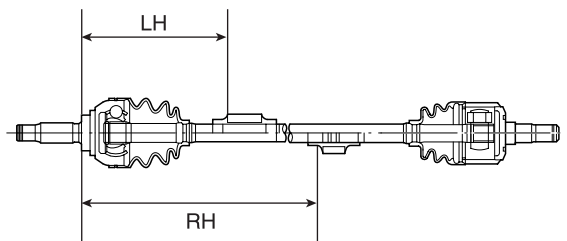

AIGE005C

- Install the TJ boot bands and TJ boot.
- Using the alignment marks(D) made during disassembly as a guide, install the spider assembly(A) and snap ring(B) on the driveshaft splines(C).

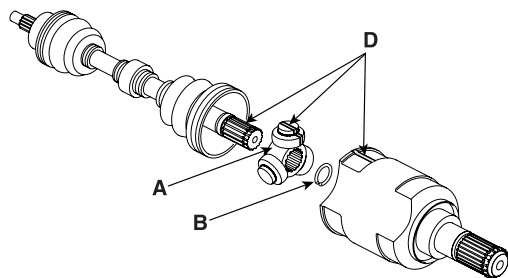

BIGE007D

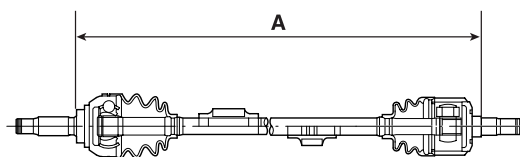

BIGE007F

FRONT AXLE

FRONT HUB/KNUCKLE

COMPONENTS EDAEBB9C

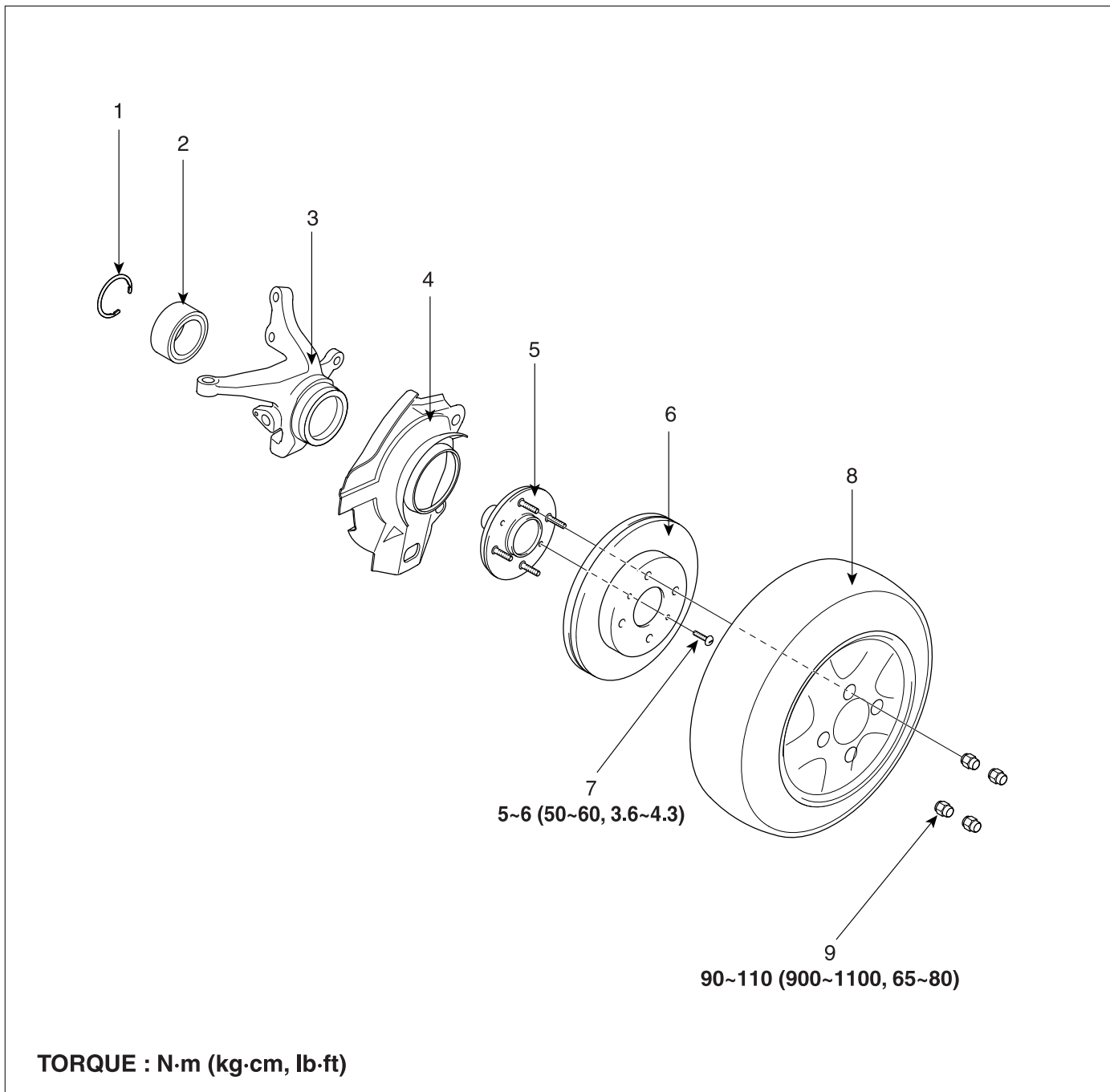

- | | |
|--------------------------------|----------------------------------|
| 1. Snap ring | 6. Front wheel brake disc |
| 2. Front wheel hub bearing | 7. Front brake disc fixing screw |
| 3. Front axle assembly | 8. Front wheel/tire |
| 4. Front brake disc dust cover | 9. Front wheel nut |
| 5. Front wheel hub assembly | |

REMOVAL E6F2F06B

1. Remove the front wheel and tire.
2. While applying the brakes, remove the split pin(A), then remove the locknut(B) and washer from the front hub(C).

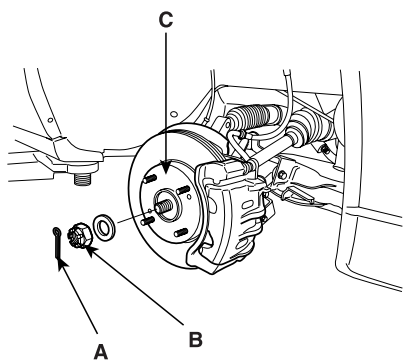

AIGE001A

3. Remove the caliper(A) from the knuckle(B) and hang the caliper(A) on the front damper(C) with wire(D).

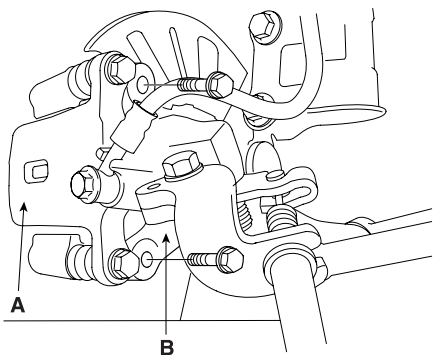

BIGE009B

4. Remove the wheel speed sensor(A) from the knuckle(B).

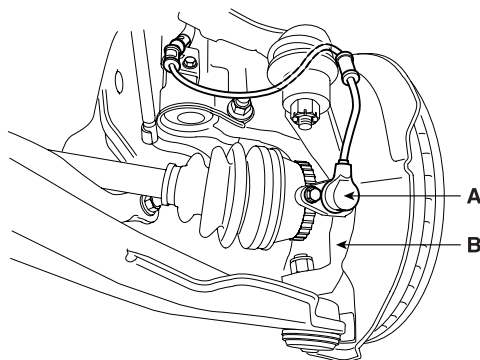

BIGE009D

5. Disconnect the tie rod end ball joint(A) from the knuckle(D) using the special tool(09568-34000).

 **NOTE**

Be sure to secure the ball joint, remove tool to the vehicle so that it doesn't fall when the joint is removed.

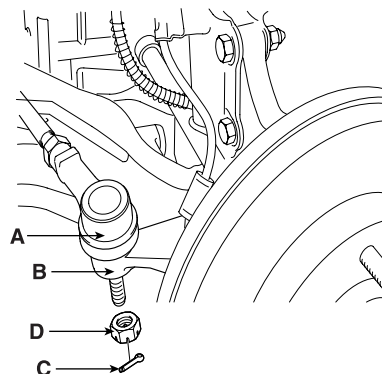

AIGE006C

- a. Remove the split pin(C).
- b. Remove the lock nut (D).

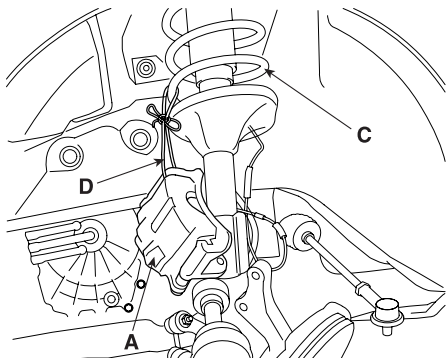

BIGE009C

- c. Disconnect the ball joint(A) from knuckle(B) using the special tool (09568-34000).

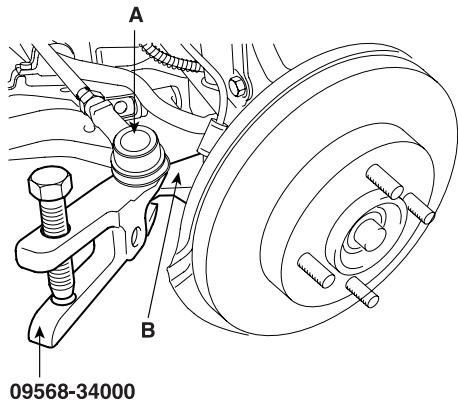

AIGE001B

- 6. Disconnect the strut assembly from the knuckle.
- 7. Disconnect the lower arm ball joint from the knuckle using the special tool.
- 8. Remove the hub and knuckle as an assembly.



CAUTION

Be careful not to damage the boot and tone wheel.

DISASSEMBLY

ECEBFFE9

- 1. After removing the fixed screws(A) mounting the brake disc(C), remove the brake disc(C) from the hub(B).

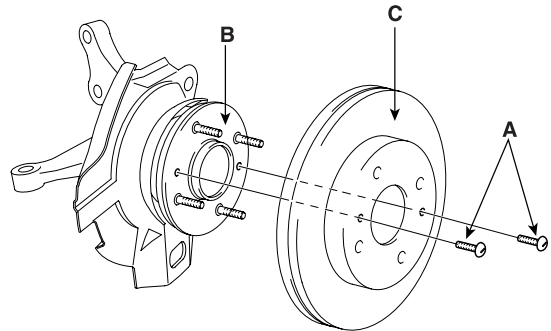

BIGE010A

- 2. Remove the snap ring(A).

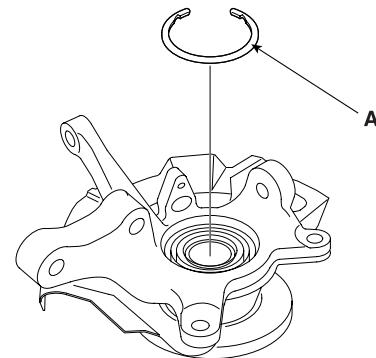

BIGE010B

- 3. Install the special tools(09517-29000, 09517-21500) as shown in illustration below.

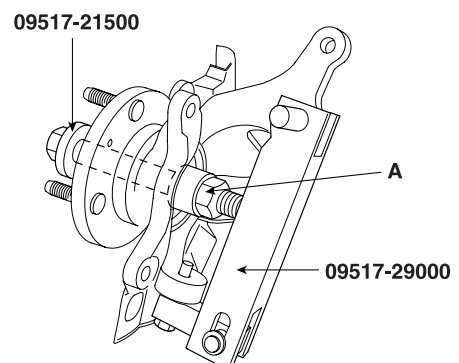

BIGE010C

4. Separate the hub from the knuckle by turning nut(A) of the special tool(09517-21500).
5. Using a plastic hammer, remove the dust cover from the knuckle.
6. Remove the bearing inner race(B) from the hub(A) using the special tool (09495-33000).

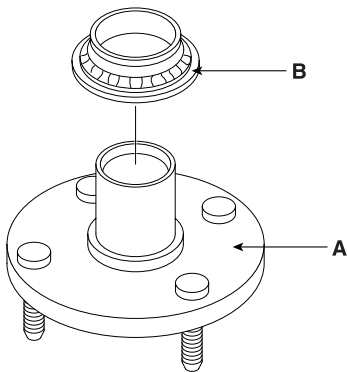

BIGE010D

7. Using the special tools (09495-33100, 09517-29000), remove the wheel bearing outer race(A) from the knuckle(B).

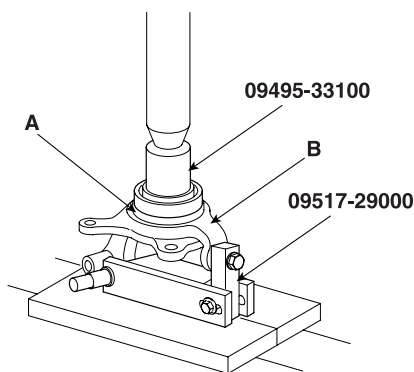

BIGE010E

INSPECTION E0DBFEA9

Wheel Bearing Check

1. Raise the vehicle until the front tires are off the floor.
- Make sure the wheels are in a straight forward position.

NOTE

Make sure the wheel rotates freely and that the brake pads are retracted sufficiently to allow free movement of the tire and wheel assembly.

Spin the tire by hand to check the wheel bearings for roughness.

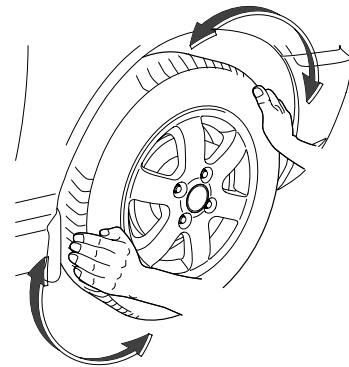

BIGE011A

2. Grip each front tire at the top and bottom and move the wheel inward and outward while lifting the weight of the tire off the front wheel bearings.

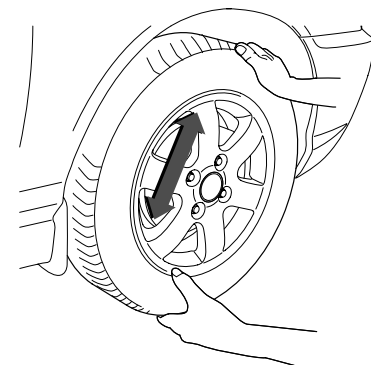

BIGE011B

3. If the tire and wheel (hub) is loose on the spindle, does not rotate freely, or has a rough feeling when spun, carry out one of the following.
On vehicles with inner and outer bearings, inspect the bearings and races for wear or damage. Adjust or install new bearing and races as necessary.

DS -20

DRIVE SHAFT AND AXLE

4. Check the hub for cracks and the splines for wear.
5. Check the brake disc for scoring and damage.
6. Check the knuckle for cracks.
7. Check the bearing for cracks or damage.

REASSEMBLY E69A8475

1. Apply multi-purpose grease to the contacting surface of the knuckle hub and bearing thinly.
2. Using the Special Tool (09532-11500), press-in the bearing to the knuckle.
 - a. Install the snap ring.

NOTE

- Press-in the outer race of the wheel bearing to prevent damage to the bearing assembly.
- When installing a bearing assembly, always use a new one.
- The right and the left bearings must be replaced as a matched set.

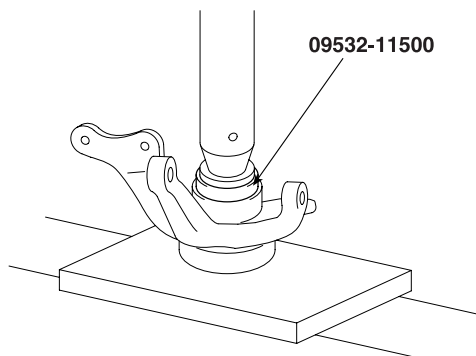

BIGE012A

3. Using a plastic hammer, install the dust cover.
4. Press-in the hub to the knuckle.

NOTE

Press-in the inner race of the wheel bearing to prevent damage to the bearing assembly.

5. Tighten the hub and the knuckle to the specified torque using the Special Tool (09517-21500).

Specified torque Nm (kg-cm, lb-ft)
200 ~ 250 (2000 ~ 2500, 147 ~ 184)

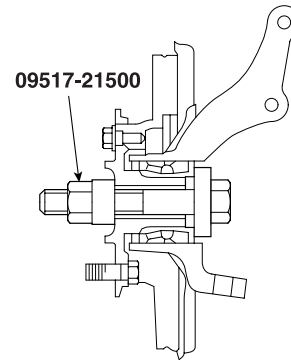

BIGE012B

6. Measure the hub bearing starting torque.

Hub bearing starting torque [Limit]
1.8 Nm (18 kg-cm, 1.3 lb-ft) or less

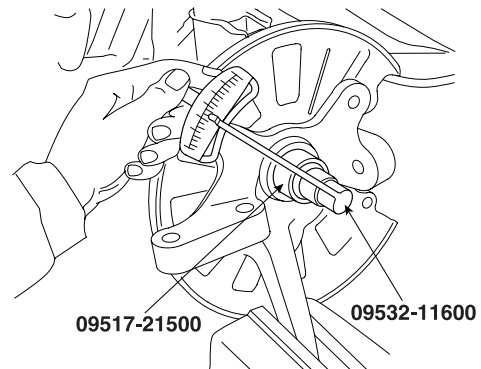

BIGE012C

7. If the starting torque is 0 Nm (0 kg-cm, 0 lb-ft), measure the hub bearing axial play.

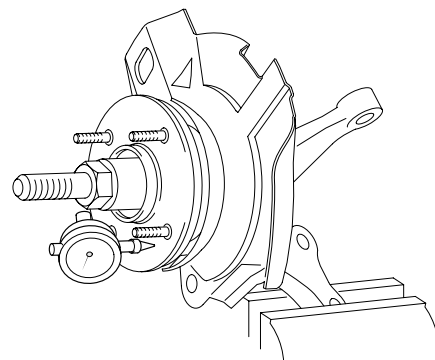

BIGE012E

8. If the hub axial play exceeds the limit while the nut is tightened to 200~260 Nm (2000~2600kg·cm, 145~188 lb·ft), the bearing, hub and knuckle are not installed correctly. Repeat the disassembly and assembly procedure.

Hub bearing axial play [Limit]
0.008 mm (0.0003 in.) or less

9. Remove the Special Tool.
10. Fix the brake disc with the mounting screws.

INSTALLATION EE1CA70C

1. Installation is the reverse of the removal procedures.

 **NOTE**

Tighten the components below to the specified torque as follows :

Items	Torque Nm (kg·cm, lb·ft)
Drive shaft lock nut	200~250 (2000~2500, 147~184)
Lower arm ball joint to knuckle nut	60~72 (600~720, 43~52)
Knuckle to strut assembly nut	130~150 (1300~1500, 94~108)

2. Install the strut assembly and the drive shaft in the knuckle.
3. Tighten the lower arm ball joint nut
4. Connect the wheel speed sensor.
5. Install the caliper assembly in the hub and knuckle assembly which the brake disc is already installed.
6. Tighten the tie rod end ball joint nut and insert the split pin.
7. Insert the washer(B) and tighten the lock nut(A).

8. Insert the split pin(C).

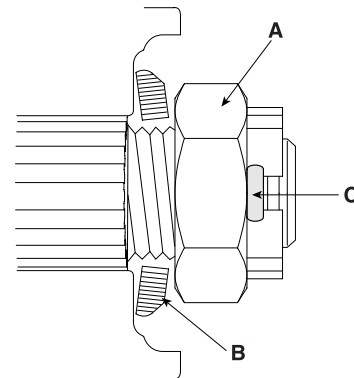

BIGE013A

9. Install the wheel and tire and tighten the wheel nuts.

REAR AXLE

REAR AXLE/HUB

COMPONENTS E3F5CDEB

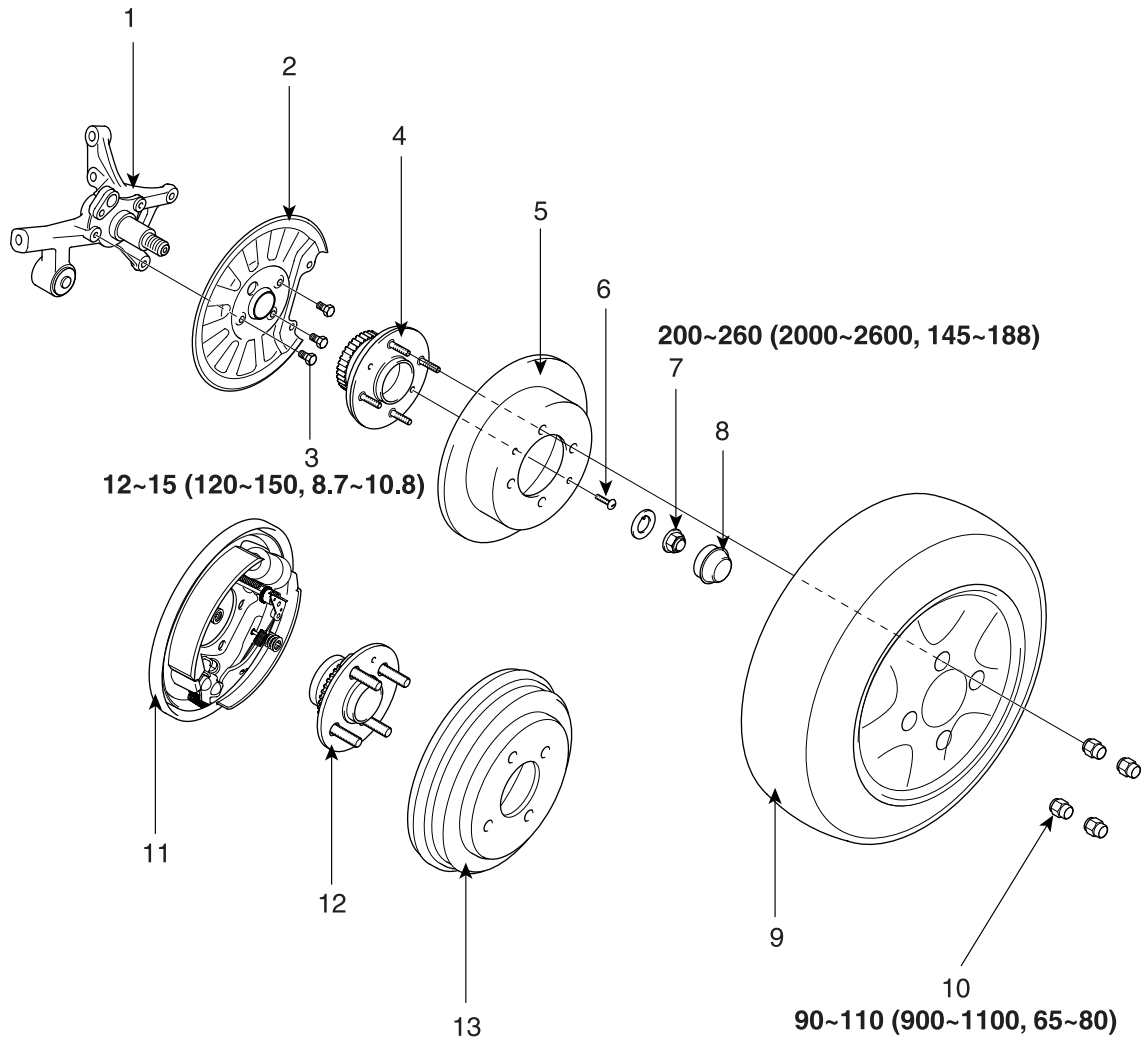

CAUTION

The right and the left bearing must be made in the same company.

TORQUE : N·m (kg·cm, lb·ft)

- | | |
|---------------------------------|------------------------------|
| 1. Rear axle carrier assembly | 8. Rear wheel hub cap |
| 2. Rear brake disc dust cover | 9. Rear wheel / tire |
| 3. Dust cover fixing nut | 10. Rear wheel nut |
| 4. Rear wheel hub assembly | 11. Rear brake shoe assembly |
| 5. Rear brake disc | 12. Rear wheel hub assembly |
| 6. Rear brake disc fixing screw | 13. Rear brake drum |
| 7. Rear wheel bearing nut | |

REAR AXLE

DS -23

REMOVAL EDA19D77

1. Loosen the wheel nuts slightly.
2. Raise rear of the vehicle.
3. Loosen the rear wheel nuts thoroughly and remove the rear wheel and tire.
4. Remove the fixed screw (A) of the brake disc (B), and then remove the brake disc (B).

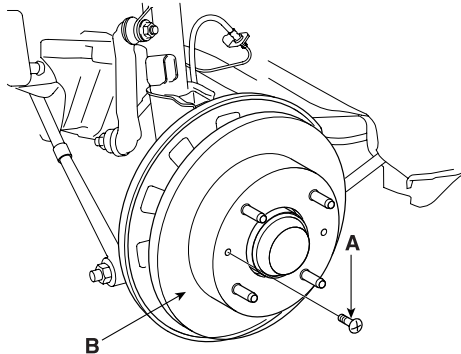

BIGE015A

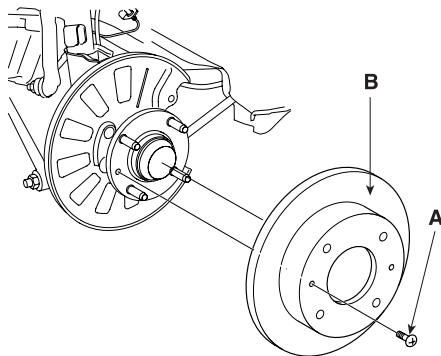

BIGE015B

5. Remove the bolt(A) and the separate the rear wheel speed sensor(B).

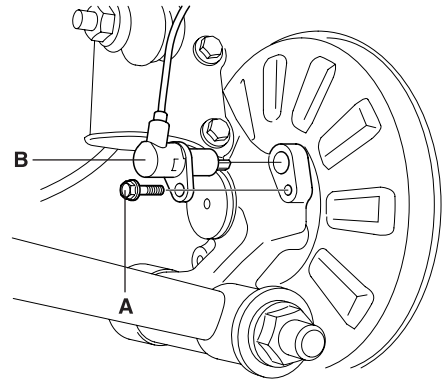

AIGE008A

6. Using a flat-tipped screwdriver, remove the wheel hub cap(A).

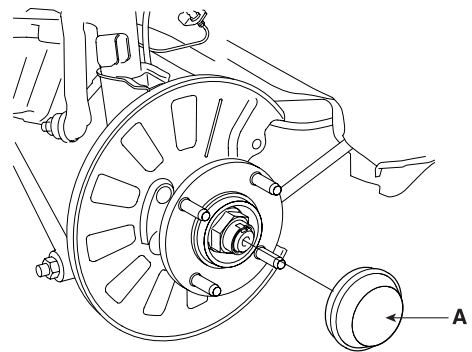

BIGE015D

7. Remove the wheel bearing nut(A).
 - a. Using a flat-tipped (-) screwdriver, spread out the groove(B) on the bearing nut(A).
 - b. Loosen the wheel bearing nut(A).

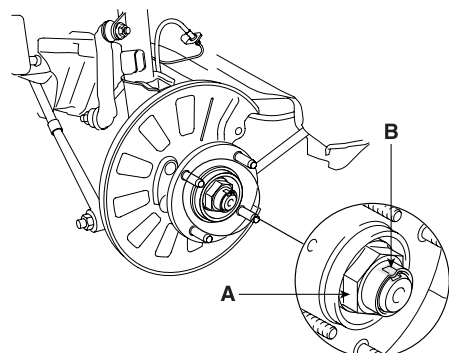

BIGE015E

8. Remove the rear wheel hub assembly(A).
Remove the bolts(B) and then remove the dust cover(C).

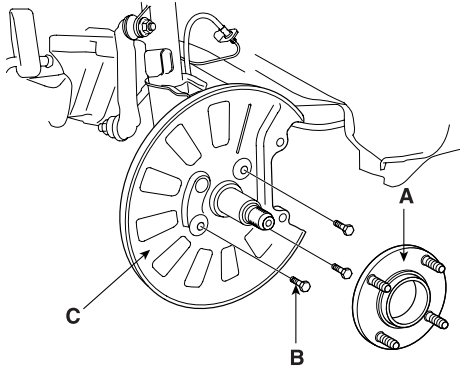

BIGE015F

9. Remove the rear axle carrier(A).
a. Loosen the 4nuts(B,C,D,E) shown in illustration below.

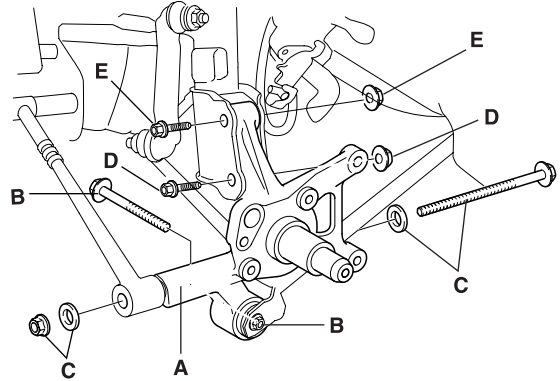

AIGE008C

NOTE

- The rear hub assembly should not be disassembled.
- (For vehicles equipped with ABS)
Care must be taken not to scratch or damage the teeth of the rotor(A). The rotor(A) must never be dropped. If the teeth of the rotor(A) are chipped, it results in deformation of the rotor(A). It will make it impossible to detect the wheel rotation speed accurately and to operate the system normally.

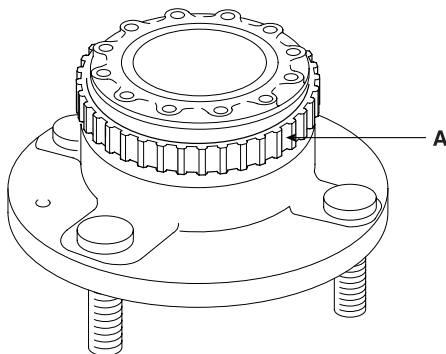

BIGE015G

INSPECTION EAB25E2B

1. Check the oil seal for cracks or damage.
2. Check the rear hub bearing for wear or damage.
3. Check the rear rotor for chipped teeth.
4. Check the rear carrier for cracks.

INSTALLATION E71FCD03

1. After tightening the wheel bearing nut, caulk the concave portion(B) of the spindle(A) by crimping the nut.

CAUTION

Replace the wheel bearing nut with new ones after removal.

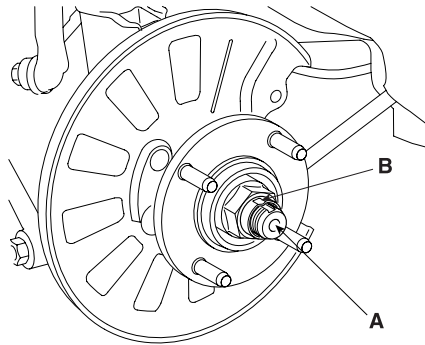

BIGE016A

2. Installation of the rear speed sensor(A) (For vehicles equipped with ABS) :
Insert a feeler gauge(C) into the space between the pole piece of the speed sensors(A) and the rotor teeth(B) surface, and then tighten the speed sensors(A) at the position where the clearance at all places is within the standard value.

Standard value

Clearance : 0.2~1.3 mm (0.008~0.051 in.)

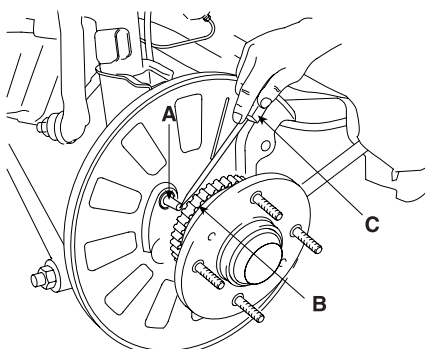

BIGE016B

3. Install the hub cap.