

## DS-2

## Driveshaft and axle

### General Information

#### Specification

Items		Inner side	Outer side
Front driveshaft	Joint type	TSJ#25	BJ#25
	Max. permissible angle	20°	43°
Rear driveshaft	Joint type	TSJ#26	BJ#28
	Max. permissible angle	20°	43°
Front differential	Oil type	Hypoid gear oil(API GL-5, SAE 75W/90)	
	Oil capacity (L)	About1.3~1.4	
	Reduction gear type	Hypoid gear	
	Reduction gear ratio	3.818	
	Final drive gear backlashmm (in.)	0.13 ~ 0.18	
	Differential gear backlashmm(in.)	0.1	
Rear differential	Oil type	Hypoid gear oil(API GL-5, SAE 75W/90)	
	Oil capacity (L)	About1.7~1.9	
	Reduction gear type	Hypoid gear	
	Reduction gear ratio	3.818	
	Final drive gear backlashmm (in.)	0.13 ~ 0.18	
	Differential gear backlashmm(in.)	0.1	

# General Information

**DS-3**

## Tightening torque

Items		Nm	Kgf-m	lb-ft
Front	Wheel nut	88.3~107.9	9~11	65.1~79.6
	Driveshaft nut	240.2~269.6	24.5~27.5	177.2~198.9
	Strut assembly lower mounting bolt	152.0~171.6	15.5~17.5	112.1~126.6
	Inner shaft bearing bracket bolt	88.3~107.9	9~11	65.1~79.6
	Break caliper mounting bolt	88.3~98.1	8.5~10	57.9~72.3
	Wheel speed sensor mounting bolt	6.9~10.8	0.7~1.1	5.1~8.0
	Break disc mounting screw	4.9~5.9	0.5~0.6	3.6~4.3
	Lower arm assembly mounting bolt	137.2~156.9	14~16	101.2~115.7
	Lower arm ball joint mounting bolt	98.1~117.7	10~12	72.3~86.8
	Tie rod end ball joint mounting nut	58.8~78.4	6.0~8.0	43.3~57.8
Rear	Wheel nut	88.3~107.9	9~11	65.1~79.6
	Driveshaft castle nut	196.1~255.0	20~26	144.7~188.1
	Shock absorber upper mounting bolt	137.3~156.9	14~16	101.3~115.7
	Shock absorber upper mounting nut	98.1~117.7	10~12	72.3~86.8
	Break caliper mounting bolt	63.7~73.5	6.5~7.5	47.0~54.2
	Wheel speed sensor mounting bolt	6.9~10.8	0.7~1.1	5.1~8.0
	Break disc mounting screw	4.9~5.9	0.5~0.6	3.6~4.3
	Hub assembly mounting bolt	78.5~88.3	8~9	57.9~65.1
	Upper arm ball joint mounting nut	78.5~88.3	8~9	57.9~65.1
	Lower arm mounting bolt	137.3~156.9	14~16	101.3~115.7
	Assist arm ball joint mounting nut	98.1~117.7	10~12	72.3~86.8
	Trailing arm mounting bolt	137.3~156.9	14~16	101.3~115.7
Front propeller shaft	Propeller shaft of the differential side mounting bolt	25.4~32.3	2.6~3.3	18.0~23.8
	Propeller shaft of the transfer side mounting bolt	58.8~68.6	6~7	43.3~50.6
Rear propeller shaft	Propeller shaft of the transaxle side mounting bolt	98.0~117.6	10~12	72.3~86.7
	Propeller shaft center bearing bracker mounting bolt	36.2~52.9	3.7~5.4	26.7~39.0
	Propeller shaft of the differential side mounting bolt	58.8~68.6	6~7	43.3~50.6

## DS-4

## Driveshaft and axle

Items		Nm	Kgf-m	lb-ft
Front differential	Air bleeder	7.8~11.7	0.8~1.2	5.7~8.6
	Differential cover bolt	37.2~51.9	3.8~5.3	27.4~38.3
	Oil casting plug	39.2~53.9	4.0~5.5	28.9~39.7
	Oil drain plug	39.2~53.9	4.0~5.5	28.9~39.7
	Diffcarrier mounting bolt(Front)	107.8~137.2	11~14	79.5~101.2
	Diffcarrier mounting bolt(Rear)	88.2~107.8	9~11	65.0~79.5
Rear differential	Air breeder	9.8~19.6	1~2	7.2~14.4
	Differential cover bolt	39.2~49.0	4~5	28.9~36.1
	Oil casting plug	39.2~49.0	4~5	28.9~36.1
	Oil drain plug	39.2~49.0	4~5	28.9~36.1
	Diffcarrier mounting bolt(Front)	107.8~137.2	11~14	79.5~101.2
	Diffcarrier mounting bolt(Rear)	88.2~107.8	9~11	65.0~79.5

### CAUTION

Replace self-locking nuts with new ones after removal.



### Lubricants

Items		Lubricants	Quantity
Front driveshaft	BJ	RBA	160g
	TSJ	RBA	130g
Rear driveshaft	BJ	RBA	210g
	TSJ	RBA	150g

# General Information

DS-5

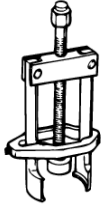
## Special tools

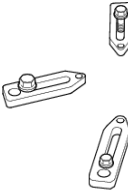
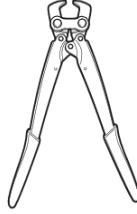
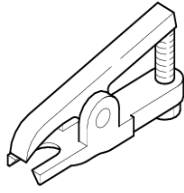
Tool(Number and Name)	Illustration	Use
09495-33000 Puller	 D9533000	Removal of spider assembly from a drive shaft.
09517-43101 Working base	 E1743101	Support for the differential carrier
09517-43500 Adapter	 E1743500	Support for the differential carrier (Use with 09517-43101)
09495-3K000 Band installer	 KINF500C	Installation of ear type boot band
09568-34000 Ball joint remover	 E6834000	Removal of the rear upper arm ball joint

## DS-6

## Driveshaft and axle

Tool(Number and Name)	Illustration	Use
09568-4A000 Ball joint remover	 KPRE103I	Removal of the front lower arm and tie rod end ball joint

### Troubleshooting

Trouble Symptom	Probable cause	Remedy
Vehicle pulls to one side	Scoring of driveshaft ball joint	Replace
	Wear, rattle or scoring of wheel bearing	Replace
	Defective front suspension and steering	Adjustment or Replace
Vibration	Wear, damage or bending of driveshaft	Replace
	Driveshaft rattle and hub serration	Replace
	Wear, rattle or scratching of wheel bearing	Replace
Shimmy	Defective wheel balance	Adjustment or Replace
	Defective front suspension and steering	Adjustment or Replace
Excessive noise	Wear, damage or bending of driveshaft	Replace
	Rattle of driveshaft and worn hub splines	Replace
	Wear, rattle or scoring of wheel bearing	Replace
	Loose hub nut	Adjustment or Replace
	Defective front suspension and steering	Adjustment or Replace

# Front Axle Assembly

DS-7

## Front Axle Assembly

### Front Hub - Axle

#### Components

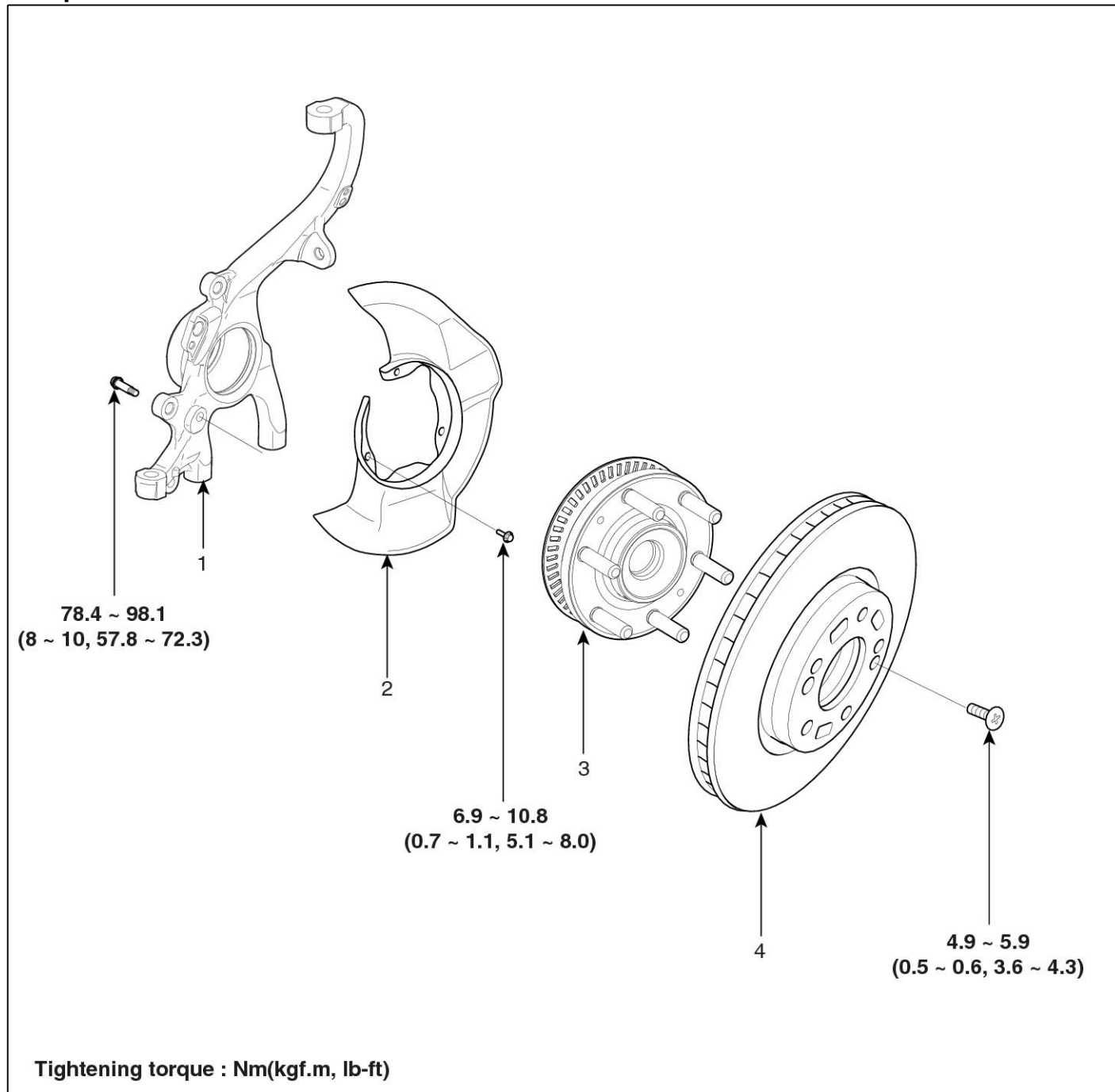

SHMDS9001L

- 1. Knuckle
- 2. Dust cover

- 3. Front hub assembly
- 4. Brake disc

## DS-8

## Driveshaft and axle

### Replacement

1. Loosen the wheel nuts slightly. Raise the vehicle, and make sure it is securely supported.
2. Remove the front wheel and tire from front hub .Caution) Be careful not to damage to the hub bolts when removing the front wheel and tire.
3. Remove castle nut(A) from the front hub under applying the break.

#### Tightening torque :

204.2~269.6N.m(24.5~27.5Kgf.m, 177.2~198.9lb.ft)

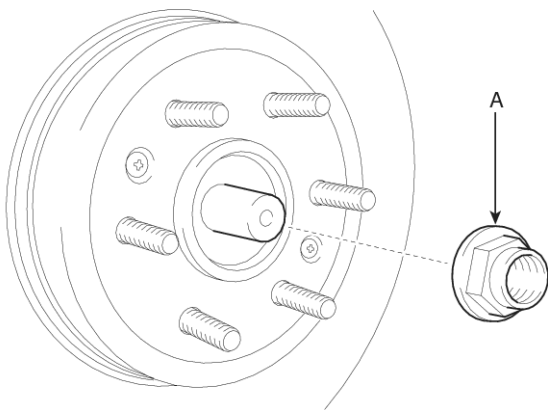

SHMDS8002D

4. Remove the brake caliper mounting bolts (A), and then place the brake caliper assembly (B) with wire.

#### Tightening torque :

83.3~98.0N.m(8.5~10.0Kgf.m, 61.4~72.3lb.ft)

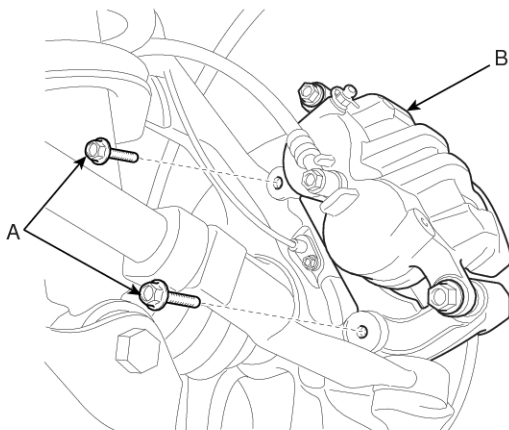

SHMDS8003D

5. Remove the tie rod end ball joint from the knuckle.
  - 1) Remove the split pin(A).
  - 2) Remove the castle nut(B).
  - 3) Disconnect the ball joint(C) from knuckle using the special tool (09568-4A000).

#### Tightening torque :

58.8~78.4N.m(6.0~8.0Kgf.m, 43.3~57.8lb.ft)

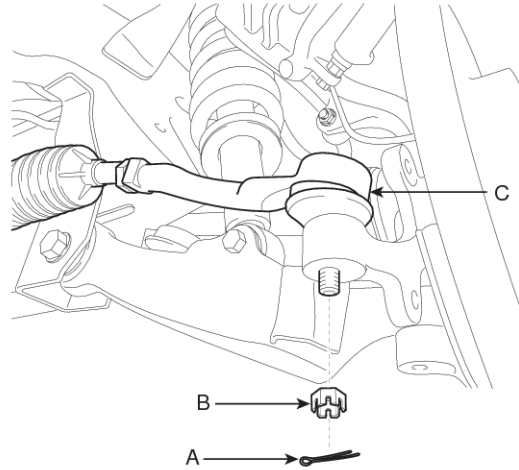

SHMDS8004D

#### ⚠ CAUTION

Apply a few drops of oil to the special tool.  
(Boot contact part)

6. Remove the wheel speed sensor(A), the strut lower mounting bolt(B) and the lower arm mounting bolt(C) from the knuckle.

#### Tightening torque :

6.8~10.8N.m( 0.7~1.1Kgf.m, 5.1~7.9lb.ft)

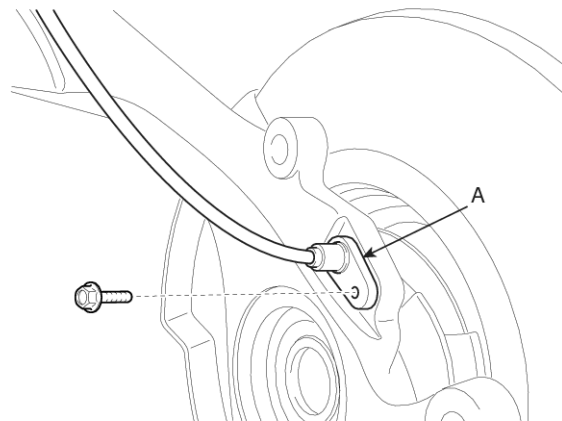

SHMDS8005D

# Front Axle Assembly

DS-9

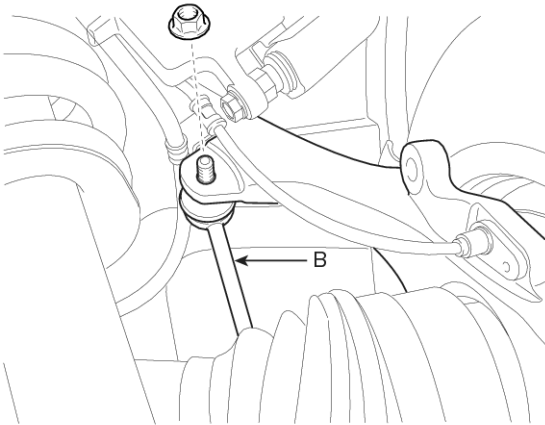

SHMDS8006D

**Tightening torque :**  
137.3~156.9N.m(14~16Kgf.m, 101.2~115.7lb.ft)

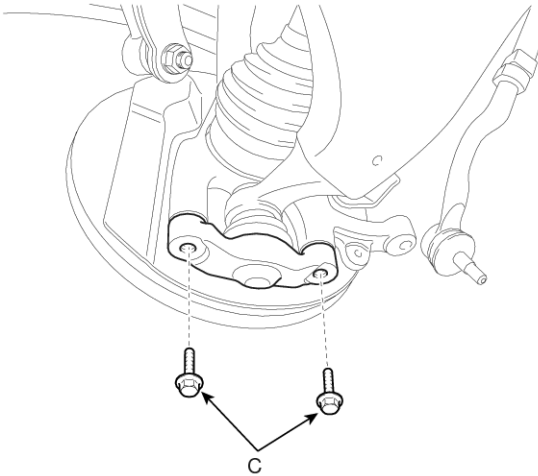

SHMDS8007D

7. Disconnect the drive shaft end(A) from knuckle.

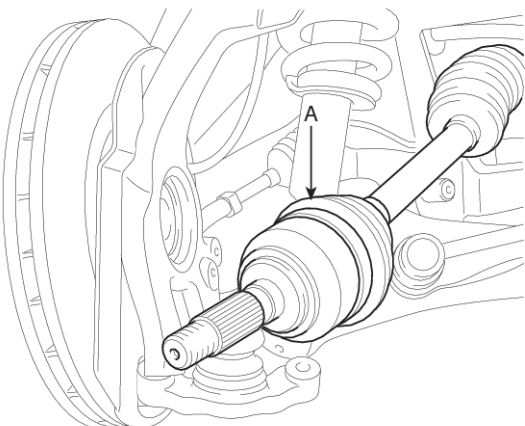

SHMDS8008D

8. Remove the hub and knuckle assembly.

- 1) Remove the split pin.
- 2) Remove the castle nut(A).
- 3) Disconnect the ball joint(C) from knuckle(D) using the special tool (09568-4A000).

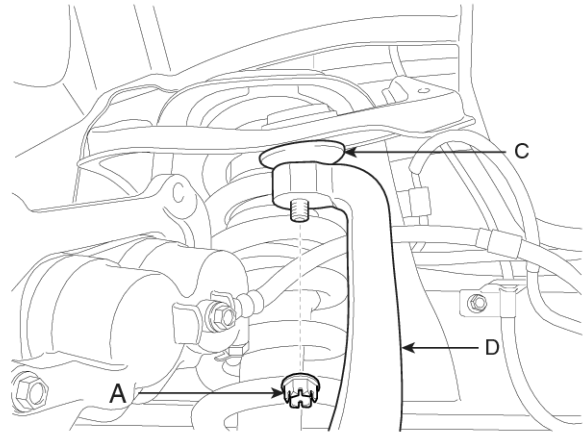

SHMDS9005L

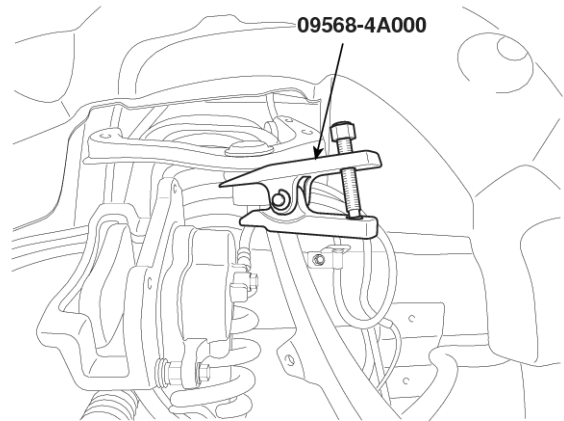

SHMDS8010D

**CAUTION**

Be careful not to damage the boot and rotor teeth.

## DS-10

## Driveshaft and axle

9. Disconnect the snap ring(A).

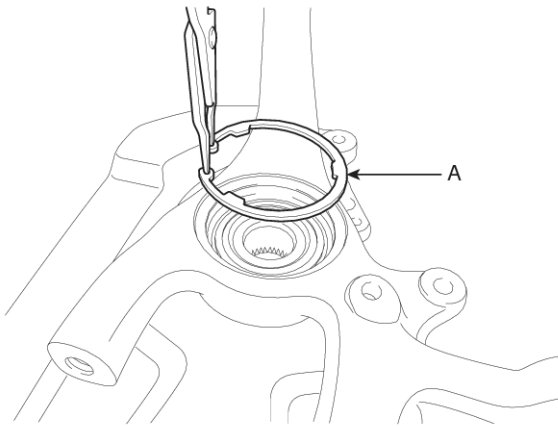

SHMDS8011D

10. Install in the reverse order of removal.

### Inspection

1. Check the hub for cracks and the splines for wear.
2. Check the brake disc for scoring and damage.
3. Check the knuckle for cracks.
4. Check the bearing for cracks or damage.

# Driveshaft Assembly

DS-11

## Driveshaft Assembly

### Front Driveshaft

#### Component location

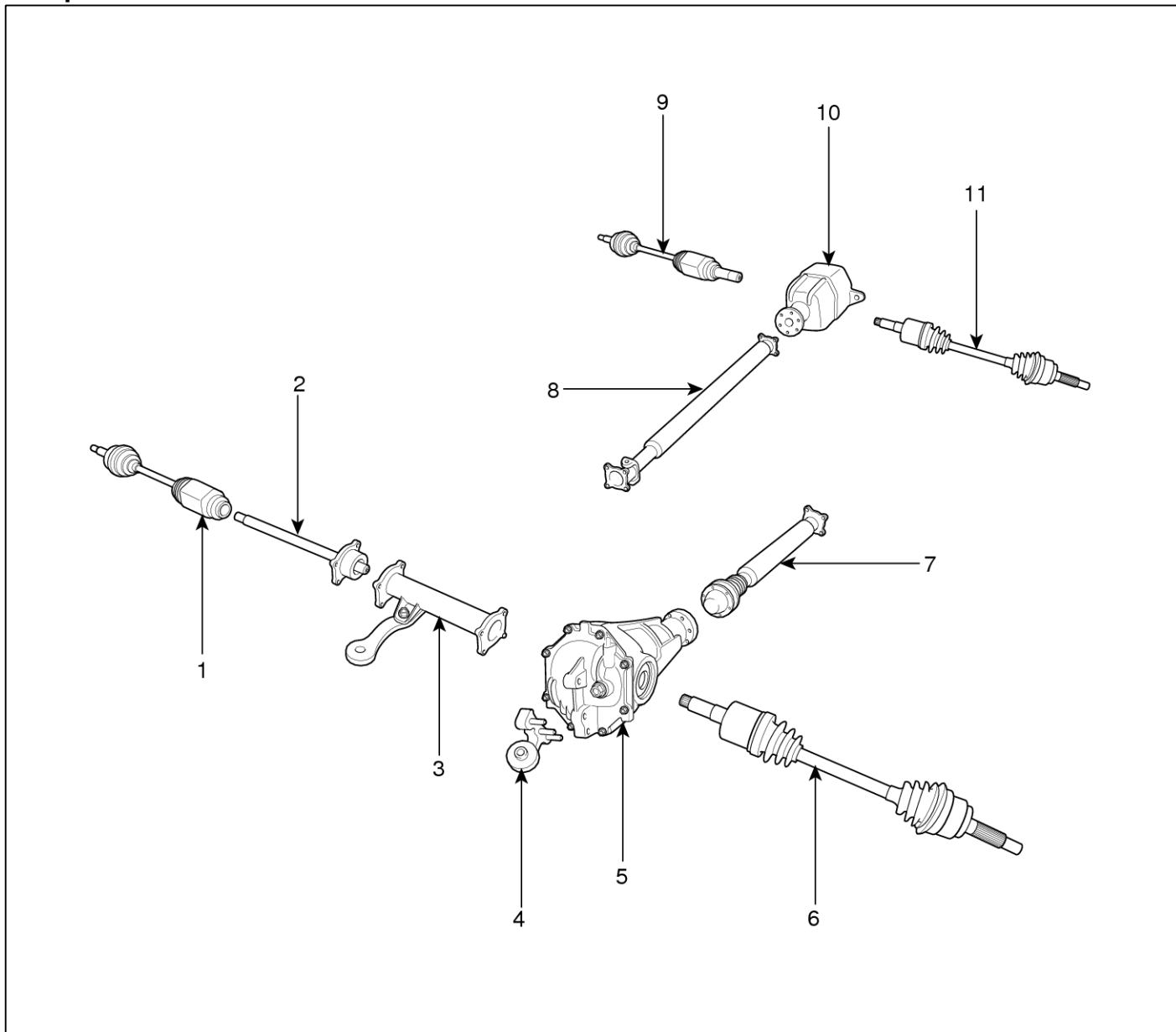

SHMDS8012D

- 1. Front driveshaft (RH)
- 2. Out shaft & bearing assembly
- 3. Outfoot shaft housing assembly
- 4. Diff mounting bracket
- 5. Front differential carrier assembly

- 6. Front driveshaft (LH)
- 7. Front propeller shaft
- 8. Rear propeller shaft
- 9. Rear drive shaft (RH)
- 10. Rear differential carrier assembly
- 11. Rear drive shaft (LH)

# DS-12

# Driveshaft and axle

[LH]

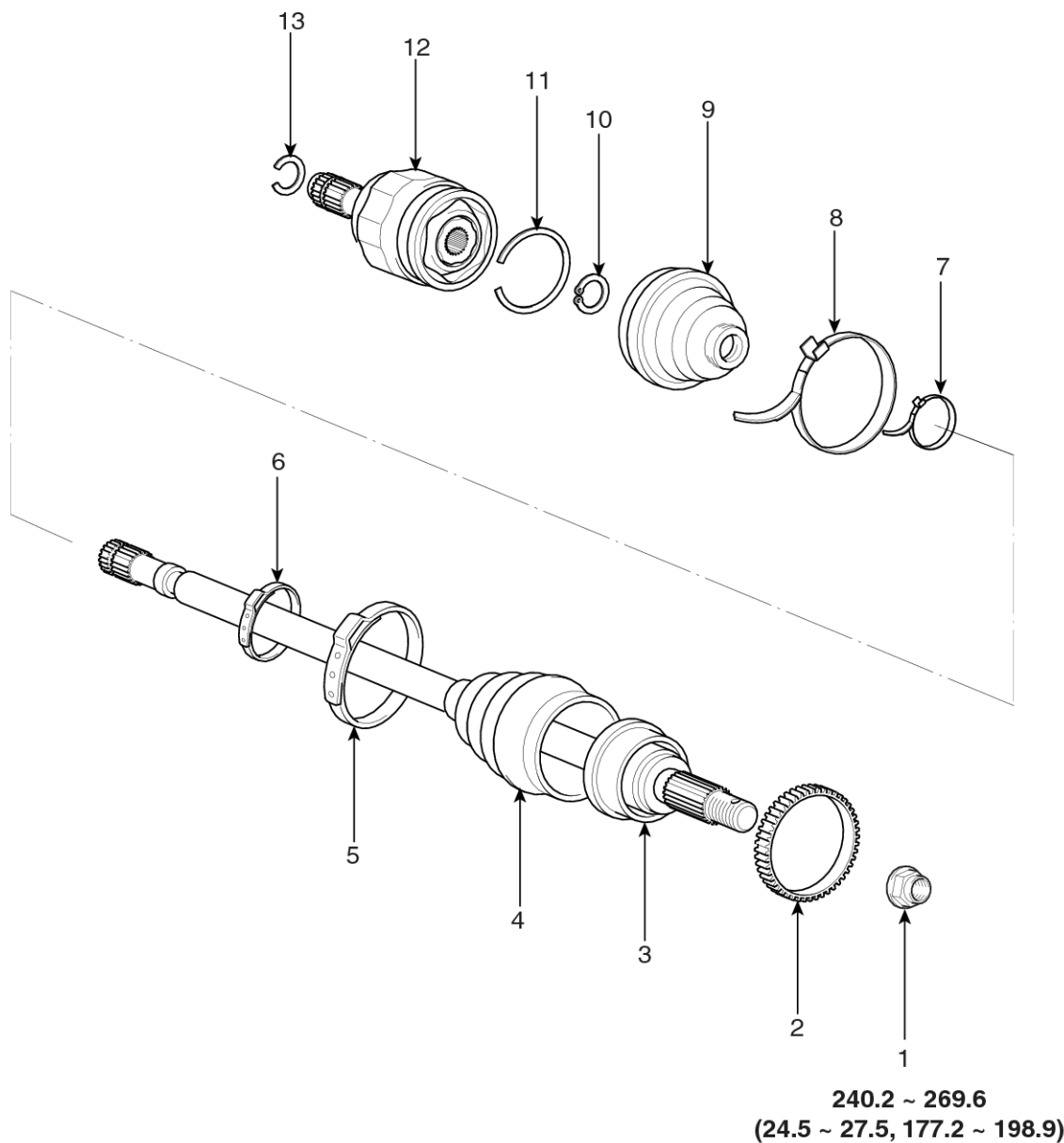

Tightening torque : Nm(kgf.m, lb-ft)

SHMDS9002L

- |                           |                 |                  |
|---------------------------|-----------------|------------------|
| 1. Drive shaft nut        | 6. BJ boot band | 11. Circlip      |
| 2. Dust cover & tone hill | 7. TSJ band     | 12. TSJ assembly |
| 3. BJ assembly            | 8. TSJ band     | 13. Circlip      |
| 4. BJ boots               | 9. TSJ boot     |                  |
| 5. BJ boot band           | 10. Clip        |                  |

# Driveshaft Assembly

DS-13

[RH]

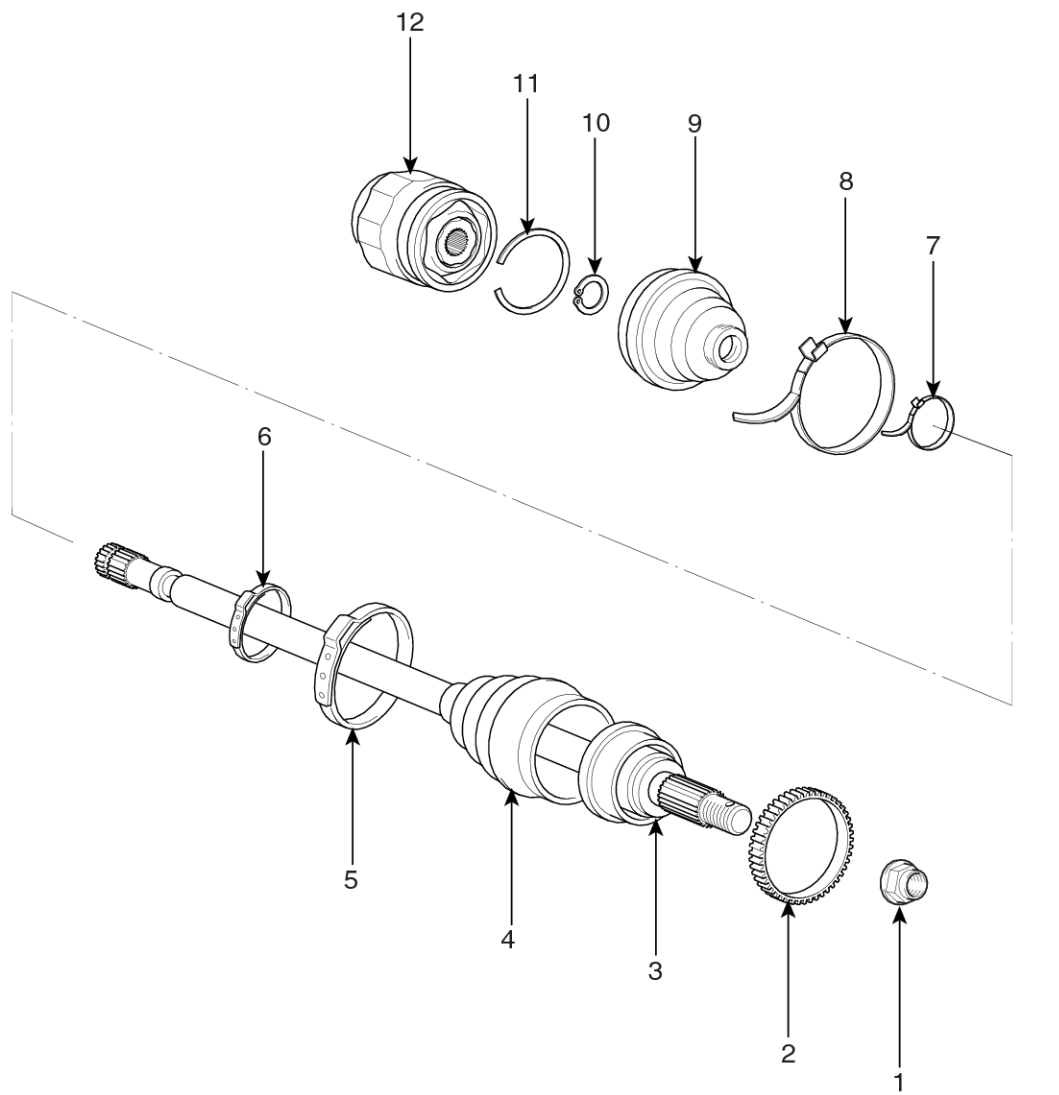

240.2 ~ 269.6  
(24.5 ~ 27.5, 177.2 ~ 198.9)

Tightening torque : Nm(kgf.m, lb-ft)

SHMDS9003L

- |                           |                 |                  |
|---------------------------|-----------------|------------------|
| 1. Drive shaft nut        | 5. BJ boot band | 9. TSJ boot      |
| 2. Dust cover & tone ring | 6. BJ boot band | 10. Clip         |
| 3. BJ assembly            | 7. TSJ band     | 11. Circlip      |
| 4. BJ boots               | 8. TSJ band     | 12. TSJ assembly |

## DS-14

## Driveshaft and axle

### Replacement

1. Loosen the wheel nuts slightly. Raise the vehicle, and make sure it is securely supported.
2. Remove the front wheel and tire from front hub .Caution)

#### **CAUTION**

Be careful not to damage to the hub bolts when removing the front wheel and tire .

3. Remove castle nut(A) from the front hub under applying the break.

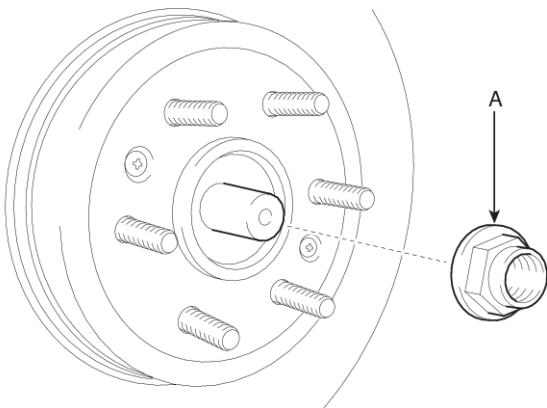

SHMDS8002D

4. Remove the brake caliper mounting bolts (A), and then place the brake caliper assembly (B) with wire.

#### **Tightening torque :**

83.3~98.0N.m(8.5~10.0Kgf.m, 61.4~72.3lb.ft)

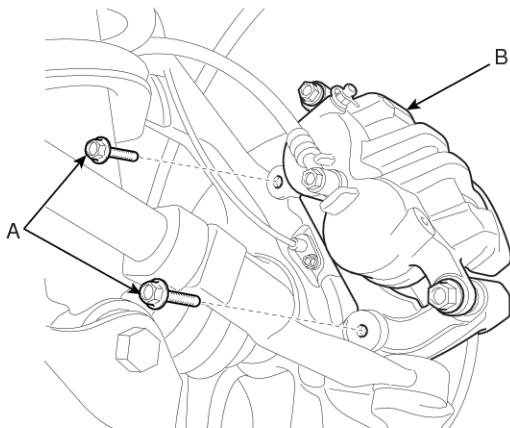

SHMDS8003D

5. Remove the tie rod end ball joint from the knuckle.

- 1) Remove the split pin(A).
- 2) Remove the castle nut(B).
- 3) Disconnect the ball joint(C) from knuckle using the special tool (09568-4A000).

#### **Tightening torque :**

58.8~78.4N.m(6.0~8.0Kgf.m, 43.3~57.8lb.ft)

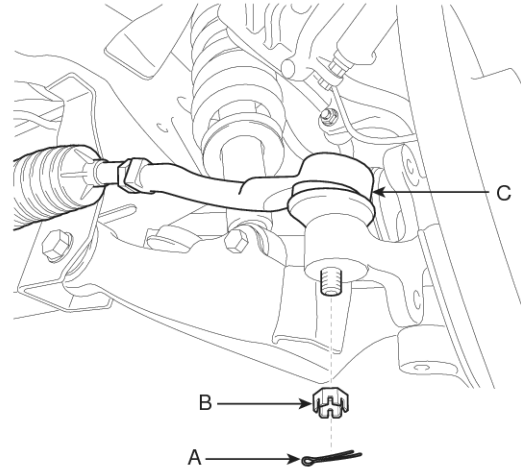

SHMDS8004D

#### **CAUTION**

Apply a few drops of oil to the special tool. (Boot contact part)

6. Remove the wheel speed sensor(A), the strut lower mounting bolt(B) and the lower arm mounting bolt(C) from the knuckle.

#### **Tightening torque :**

6.8~10.8N.m( 0.7~1.1Kgf.m,5.1~7.9lb.ft)

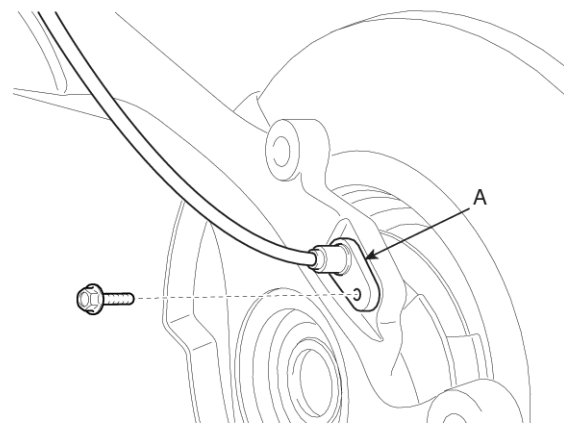

SHMDS8005D

# Driveshaft Assembly

DS-15

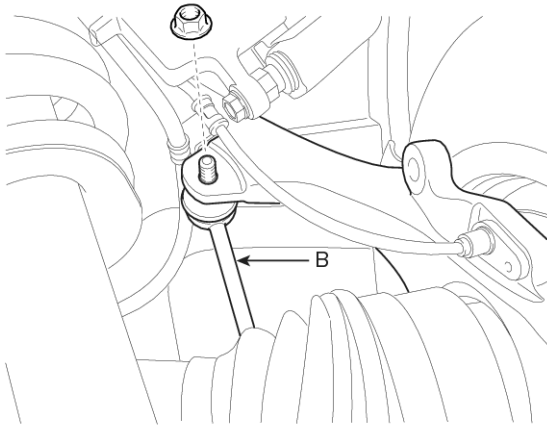

SHMDS8006D

**Tightening torque :**  
137.2~156.9N.m(14~16Kgf.m, 101.2~115.7lb.ft)

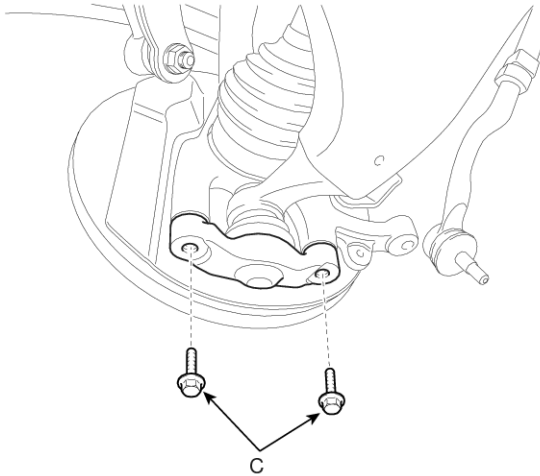

SHMDS8007D

7. Disconnect the drive shaft end(A) from knuckle.

<RH>

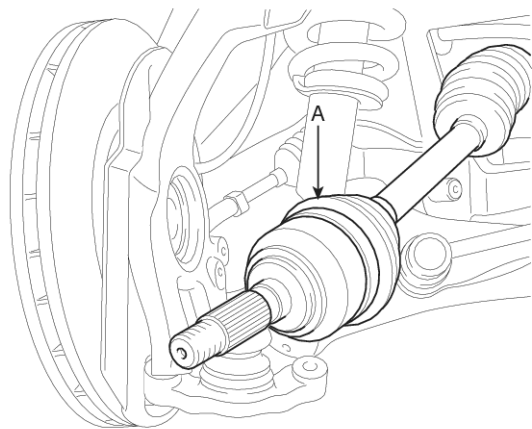

SHMDS8008D

<LH>

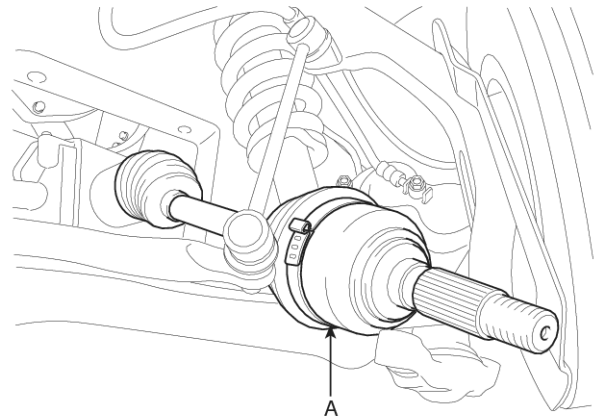

SHMDS8013D

8. Inner shaft(A) mounting bolts and then disconnect the inner shaft(B).

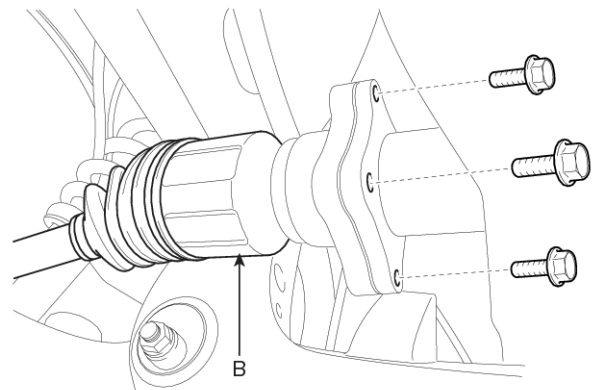

SHMDS8014D

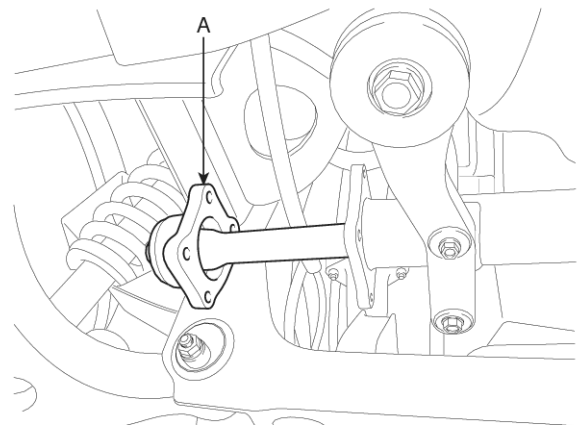

SHMDS8015D

## DS-16

## Driveshaft and axle

9. Disconnect the left driveshaft(A) from differential carrier.

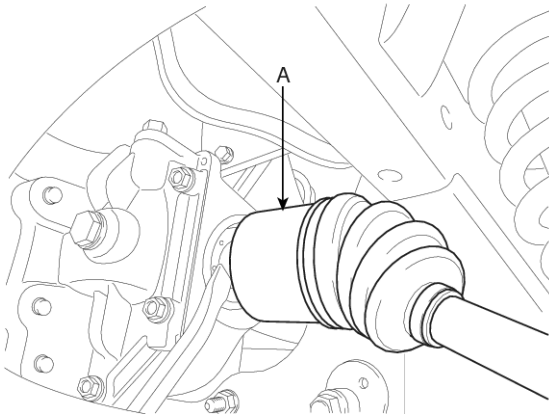

SHMDS8017D

10. Install in the reverse order of removal.

### **CAUTION**

- Use a pry bar(A) being careful not to damage the transaxle and joint.
- Do not insert the pry bar(A) too deep, as this may cause damage to the oil seal.
- Do not pull the driveshaft by excessive force it may cause components inside the joint kit to dislodge resulting in a torn boot or a damaged bearing.
- Plug the hole of the transaxle case with the oil seal cap to prevent contamination.
- Support the driveshaft properly.
- Replace the retainer ring whenever the driveshaft is removed from the transaxle case.

### Inspection

1. Check the driveshaft boots for damage and deterioration.
2. Check the ball joint for wear and damage.
3. Check the splines for wear and damage.
4. Check the dynamic damper for cracks, wear and position.

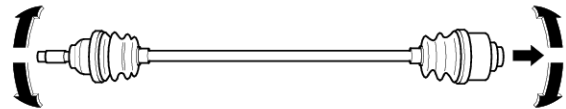

EIKD019A

5. Check the driveshaft for cracks and wears.

# Driveshaft Assembly

DS-17

## Disassembly

### ⚠ CAUTION

- Do not disassemble the BJ assembly.
- Special grease must be applied to the driveshaft joint. Do not substitute with another type of grease.
- The boot band should be replaced with a new one.

1. Remove the TSJ. boot bands and pull the TSJ. Doot from the TSJ. outer race.

- 1) Using a plier or flat-tipped (-) screwdriver, remove the LH boot band and LH TSJ. boot band from the driveshaft
- 2) Remove RH boot band and RH TSJ. boot band in the same way of LH removal procedure.

### ⚠ CAUTION

**Be careful not to damage the boot.**

2. Remove the circlip(B) with a flat-tipped (-)screwdriver(A).

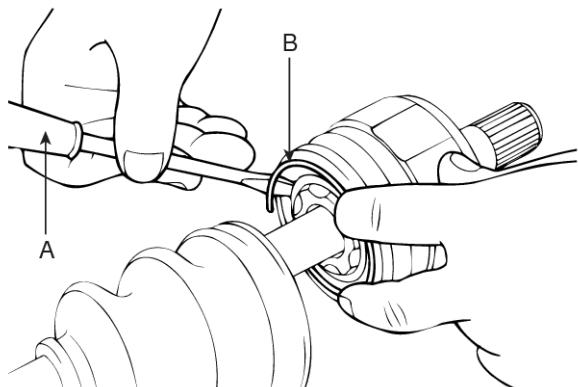

KIKD251B

3. Pull out the driveshaft from the TSJ. outer race.

4. Remove the snap ring(A) and take out the inner race(B), cage(C) and balls(D) as an assembly.

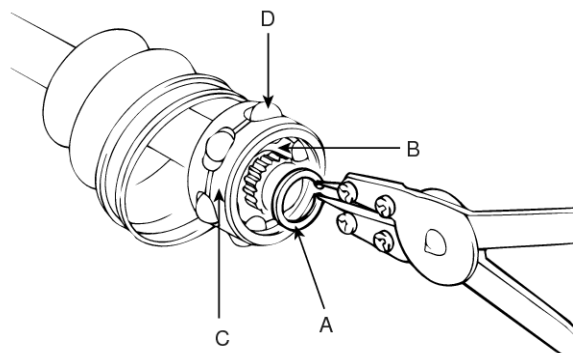

KIKD251C

5. Clean the inner race, cage and balls without disassembling.

6. Remove the BJ. boot bands and pull out the TSJ. boot and BJ. boot.

### ⚠ CAUTION

**If the boot(A) is to be reused, wrap tape(B) around the driveshaft splines(C) to protect the boot(A).**

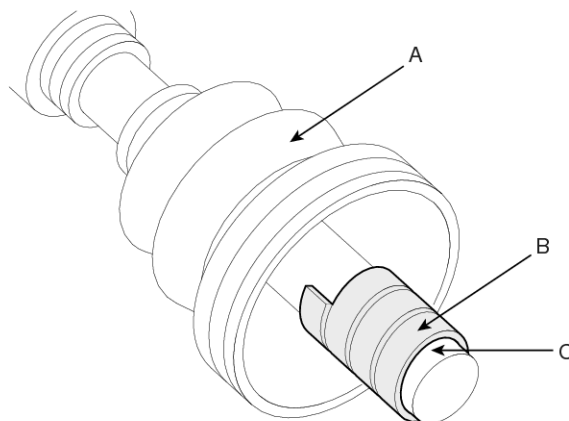

KXDDE14A

## DS-18

## Driveshaft and axle

### Reassembly

1. Wrap tape around the driveshaft splines (TSJ. side ) to prevent damage to the boots.
2. Apply grease to the driveshaft and install the boots.
3. Apply the specified grease to the inner race(A) and cage(B). Install the cage(B) so that it is offset on the race as shown.

#### **CAUTION**

Use the grease included in the repair kit.

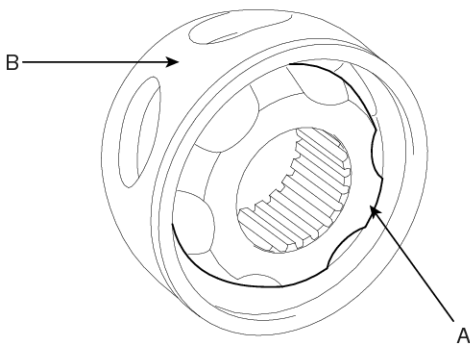

EIKD023A

4. Apply the specified grease to the cage and fit the balls into the cage.
5. Position the chamfered side(A) as shown in the illustration. Install the inner race on the driveshaft(B), and then the snap ring.

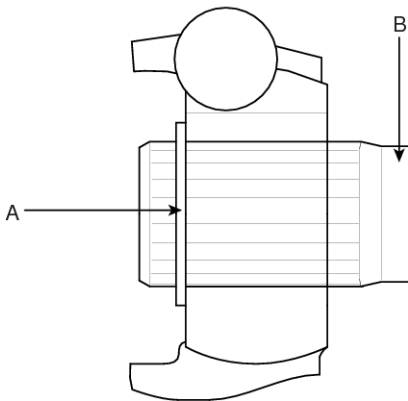

EIKD020A

6. Apply the specified grease to the outer race and install the BJ. outer race onto the driveshaft.
7. Apply the specified grease into the TSJ. boot and install the boot with a clip.

8. Tighten the TSJ. boot bands.
9. Add the specified grease to the BJ. as much as wiped away at inspection.
10. Install the boots.
11. Tighten the BJ. boot bands.
12. To control the air in the TSJ. boot, keep the specified distance between the boot bands when they are tightened.

#### **Distance (mm) :**

LH : 499.2 +21.64

-12.55

RH : 508.1 +21.64

-12.55

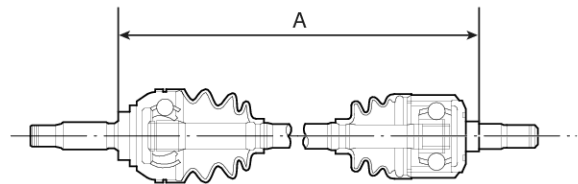

EIKD021A

# Rear Axle Assembly

DS-19

## Rear Axle Assembly

### Rear Hub - Carrier

#### Components

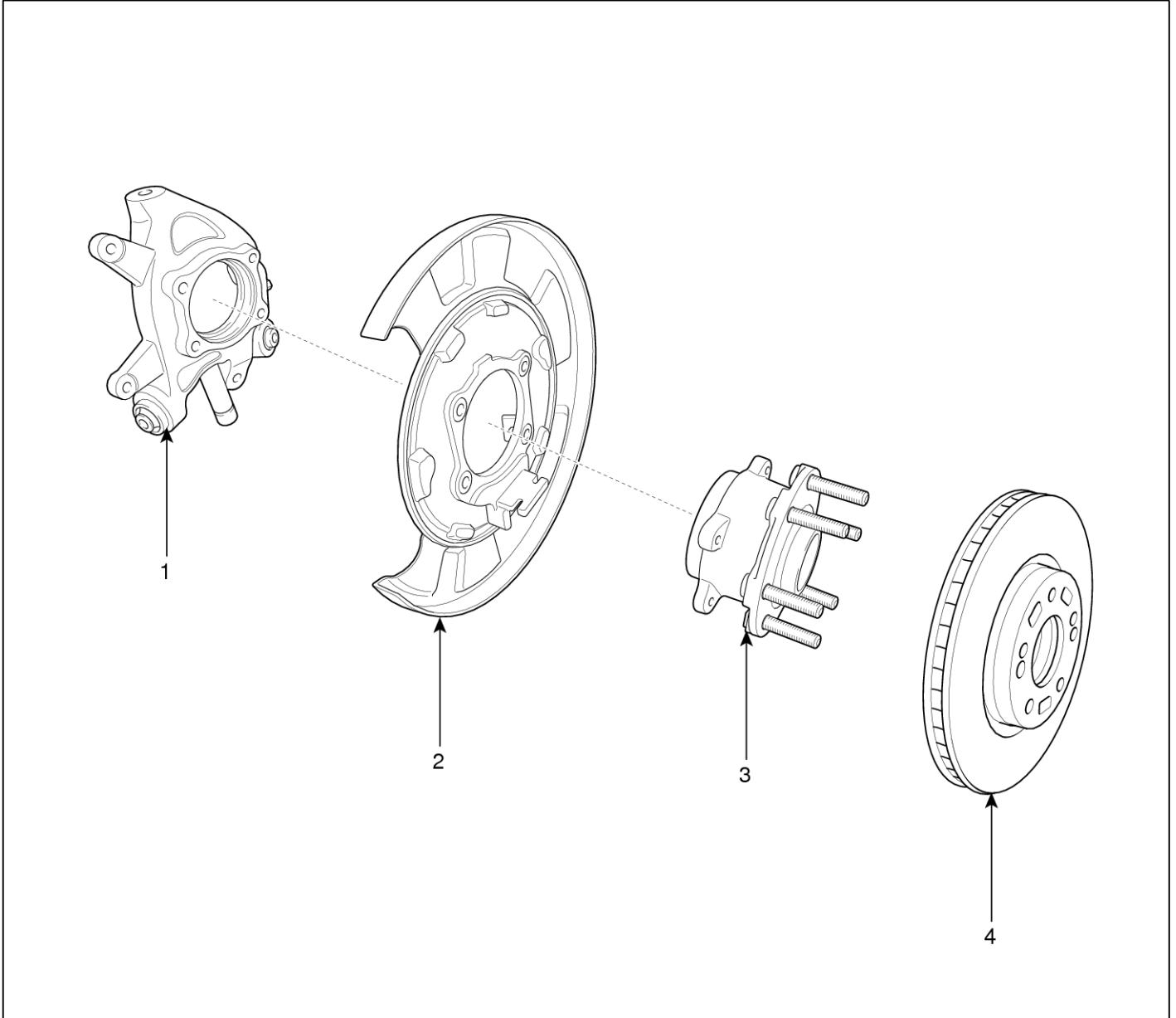

SHMDS8018D

- 1. Rear carrier assembly
- 2. Parking brake assembly

- 3. Rear hub assembly
- 4. Rear brake disc

## DS-20

## Driveshaft and axle

### Replacement

1. Loosen the wheel nuts slightly. Raise the vehicle, and make sure it is securely supported.
2. Remove the rear wheel and tire from rear hub .

#### **CAUTION**

Be careful not to damage to the hub bolts (C) when removing the rear wheel and tire (A).

3. Remove castle nut(A) from the front hub under applying the break.

#### Tightening torque :

240.2~269.6N.m(24.5~27.5Kgf.m, 177.2~198.9lb.ft)

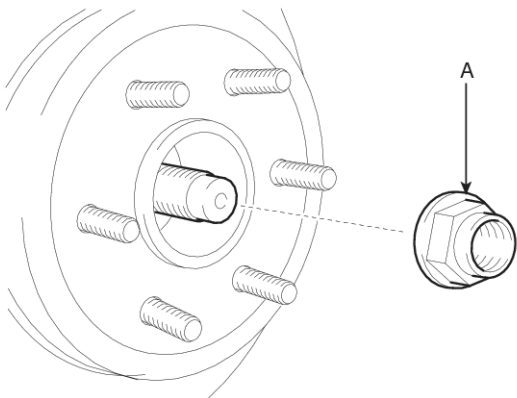

SHMDS8019D

4. Remove the rear strut assembly mounting bolt(A).

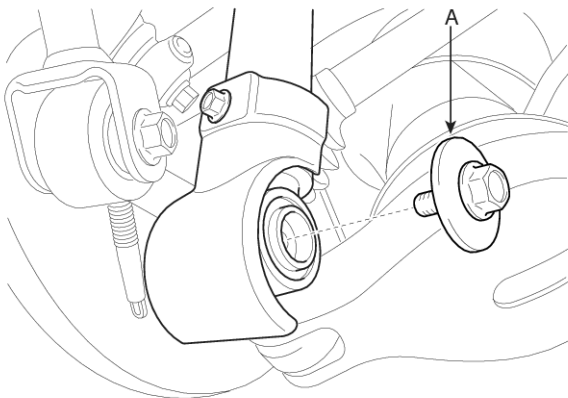

SHMDS8020D

5. Remove the assist arm(A) and the trailing arm(B) from the rear axle carrier

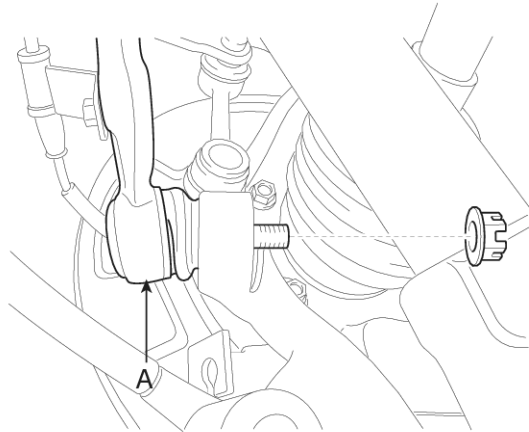

SHMDS8021D

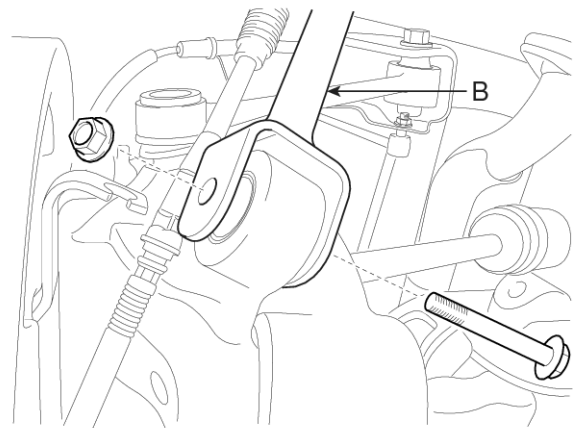

SHMDS8022D

#### **NOTICE**

Remove the rear assist arm ball joint by using the special tool(09568-4A000).

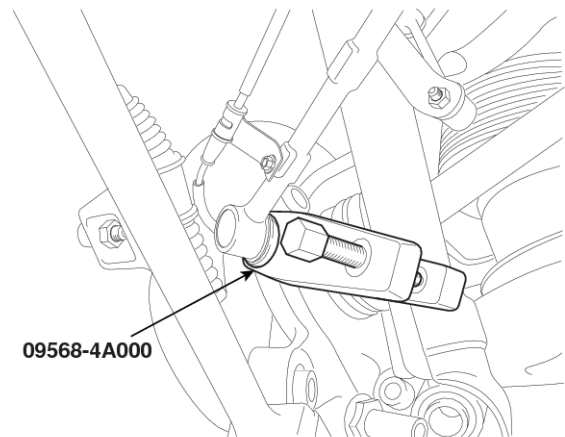

SHMDS8023D

## Rear Axle Assembly

DS-21

6. Remove the rear stabilizer link(A) from the rear axle carrier.

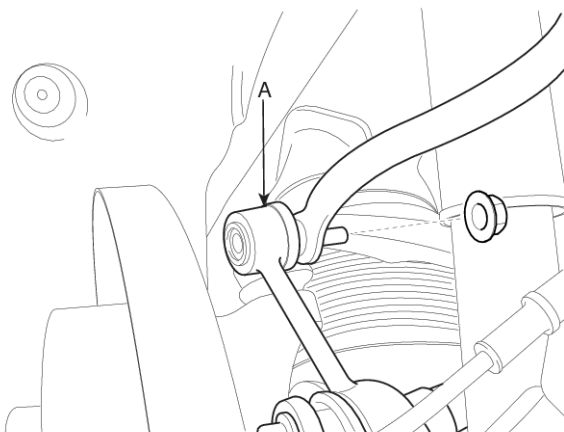

SHMDS8024D

7. Remove the brake caliper mounting bolts (A), and then place the brake caliper assembly (B) with wire as shown in the illustration.

**Tightening torque :**

83.3~98.0N.m(8.5~10.0Kgf.m, 61.4~72.3lb.ft)

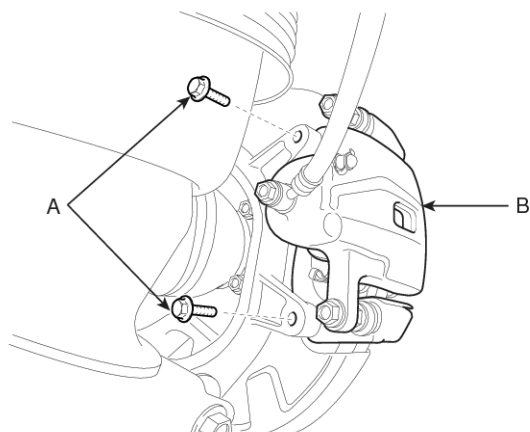

SHMDS8025D

8. Remove the wheel speed sensor(A) and the parking brake cable(B) from the rear axle carrier.

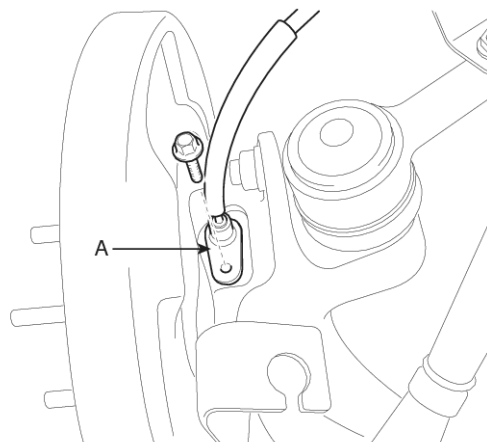

SHMDS8026D

9. Disconnect the rear shaft end(A) from knuckle.

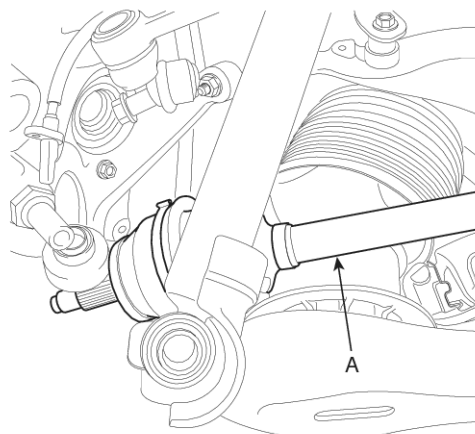

SHMDS8027D

## DS-22

## Driveshaft and axle

10. Remove the cotter pin and the castle nut (A) from the rear upper arm ball joint (B), and then remove the rear upper arm ball joint (B) by using the special tool (09568-34000).

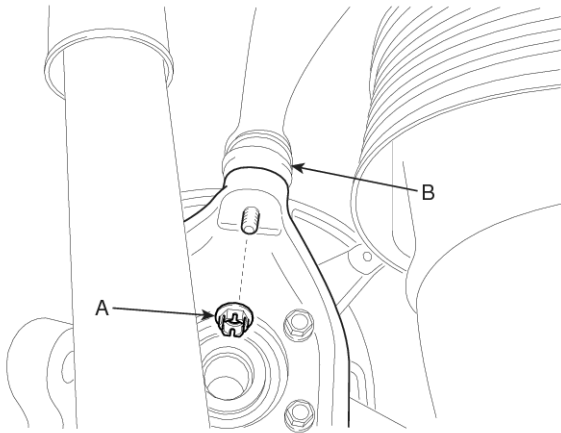

SHMDS8028D

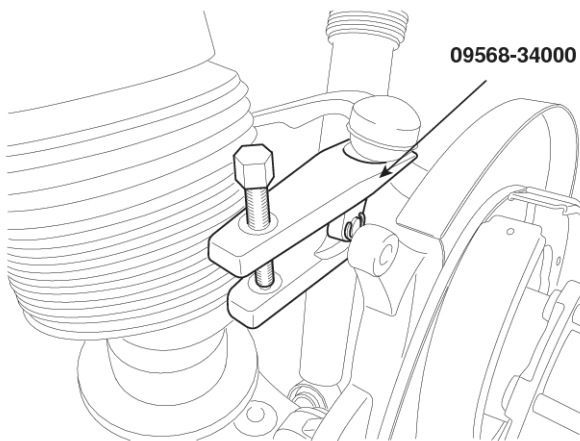

SHMDS8029D

11. Remove the hub assembly mounting bolts (B) from the rear axle carrier (A).

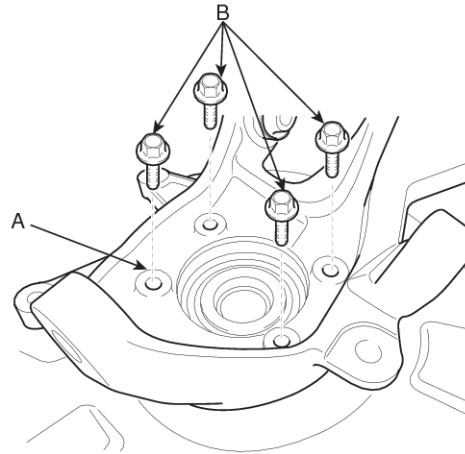

SHMDS8030D

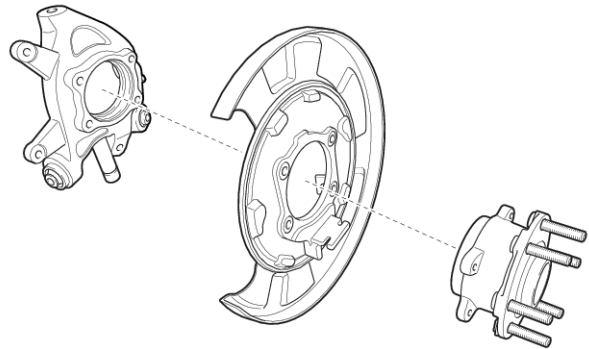

SHMDS8031D

12. Install in the reverse order of removal.

### Inspection

1. Check the hub for cracks and the splines for wear.
2. Check the brake disc for scoring and damage.
3. Check the rear axle carrier for cracks.
4. Check the bearing for cracks or damage.

# Rear Driveshaft Assembly

DS-23

## Rear Driveshaft Assembly

### Rear Driveshaft

#### Component location

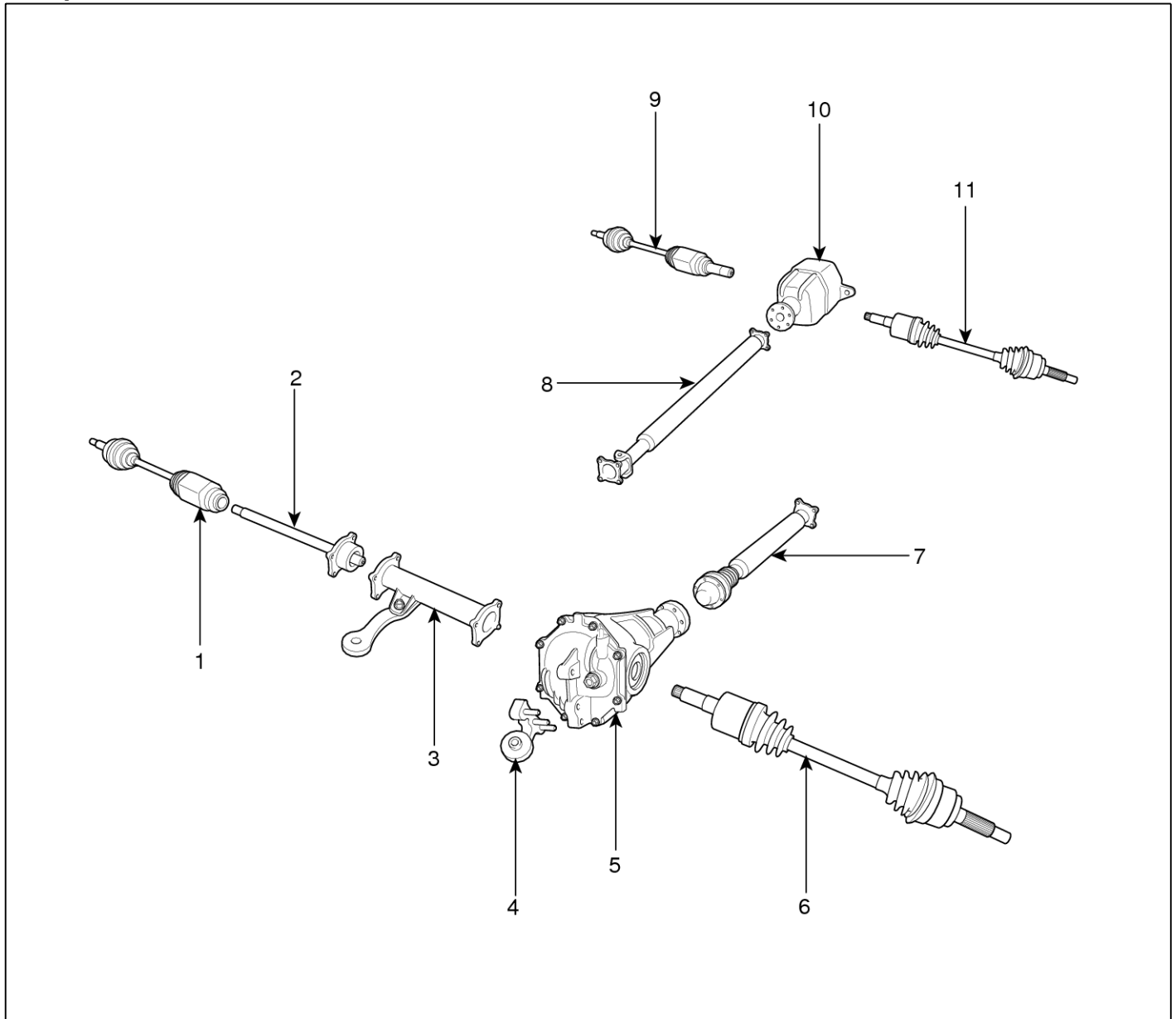

SHMDS8012D

- 1. Front driveshaft (RH)
- 2. Out shaft & bearing assembly
- 3. Outfoot shaft housing assembly
- 4. Diff mounting bracket
- 5. Front differential carrier assembly

- 6. Front driveshaft (LH)
- 7. Front propeller shaft
- 8. Rear propeller shaft
- 9. Rear drive shaft (RH)
- 10. Rear differential carrier assembly
- 11. Rear drive shaft (LH)

# DS-24

# Driveshaft and axle

## Components

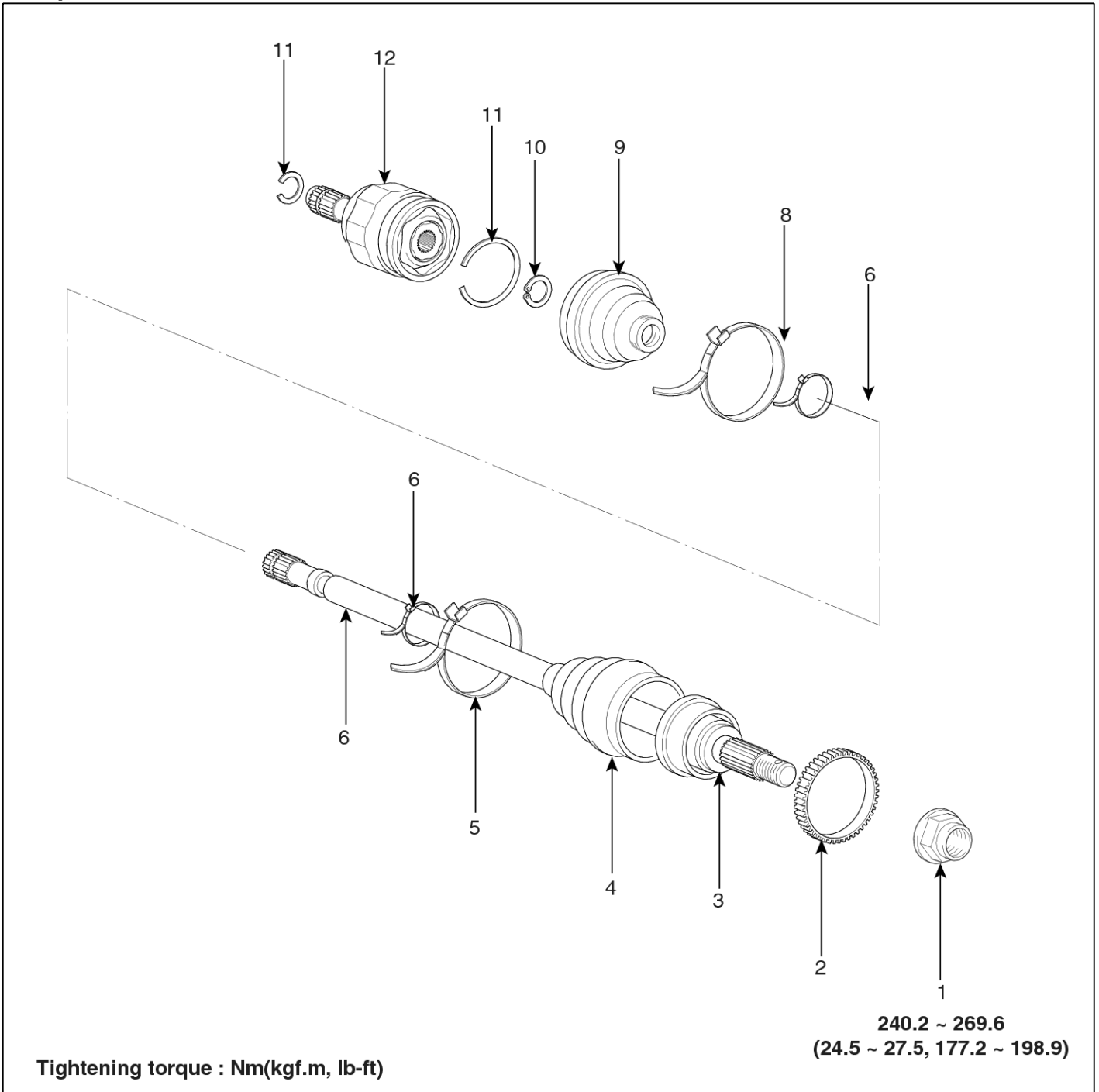

SHMDS9004L

- |                           |                           |                  |
|---------------------------|---------------------------|------------------|
| 1. Drive shaft nut        | 5. BJ boot big part band  | 9. TSJ boot      |
| 2. Dust cover & Tone ring | 6. Boot small part band   | 10. Snap ling    |
| 3. BJ assembly            | 7. Shaft                  | 11. Circlip      |
| 4. BJ boot                | 8. TSJ boot big part band | 12. TSJ assembly |

# Rear Driveshaft Assembly

DS-25

## Replacement

1. Loosen the wheel nuts slightly. Raise the vehicle, and make sure it is securely supported.
2. Remove the rear wheel and tire from rear hub.

### ⚠ CAUTION

Be careful not to damage to the hub bolts when removing the rear wheel and tire.

3. Remove castle nut(A) from the front hub under applying the break.

### Tightening torque :

240.2~269.6N.m(24.5~27.5Kgf.m, 177.2~198.9lb.ft)

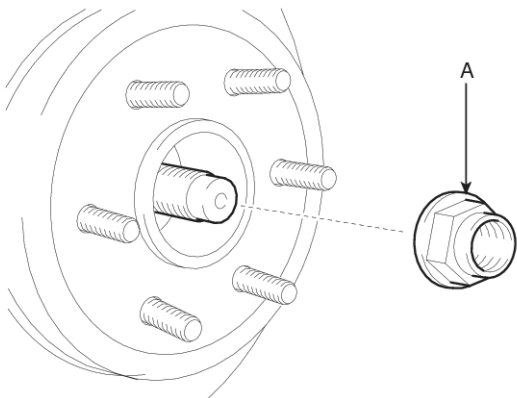

SHMDS8019D

4. Remove the rear strut assembly mounting bolt(A).

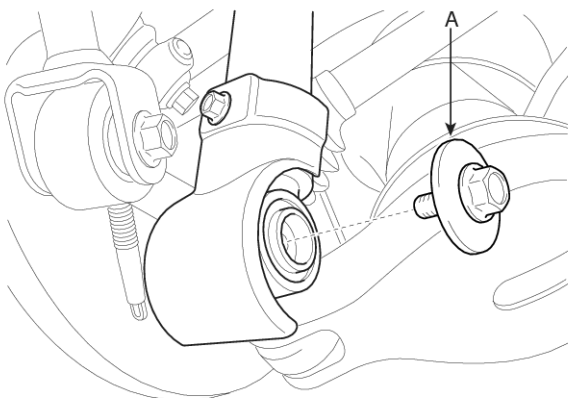

SHMDS8020D

5. Remove the assist arm(A) and the trailing arm(B) from the rear axle carrier.

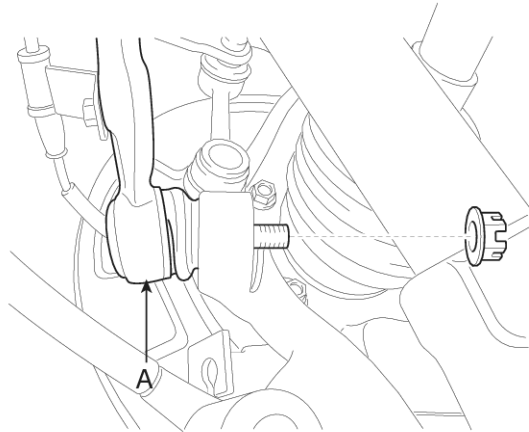

SHMDS8021D

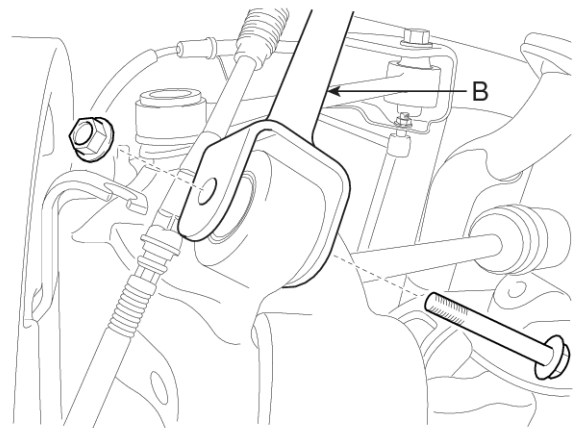

SHMDS8022D

### ⚠ NOTICE

Remove the rear assist arm ball joint by using the special tool(09568-4A000).

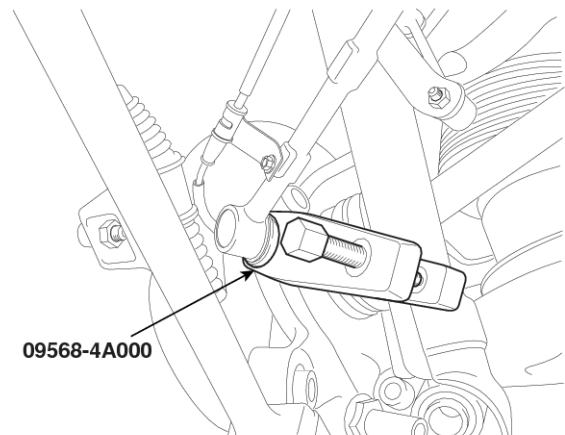

SHMDS8023D

## DS-26

## Driveshaft and axle

6. Remove the rear stabilizer link(A) from the rear axle carrier.

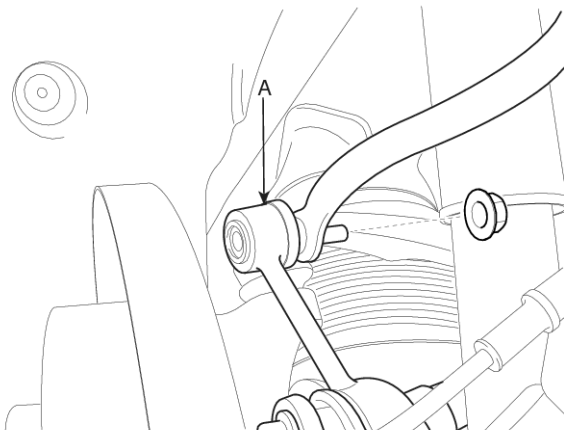

SHMDS8024D

7. Remove the brake caliper mounting bolts (A), and then place the brake caliper assembly (B) with wire as shown in the illustration.

**Tightening torque :**  
83.3~98.0N.m(8.5~10.0Kgf.m, 61.4~72.3 lb.ft)

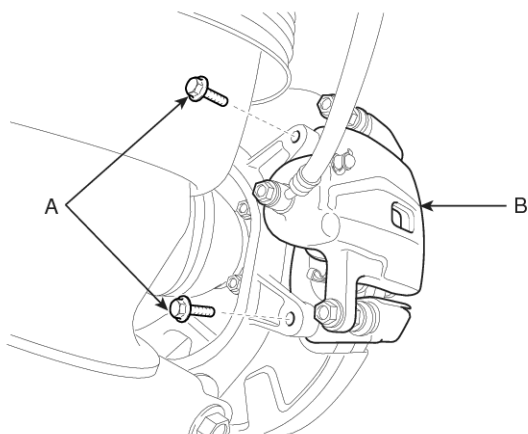

SHMDS8025D

8. Remove the wheel speed sensor(A) and the parking brake cable(B) from the rear axle carrier.

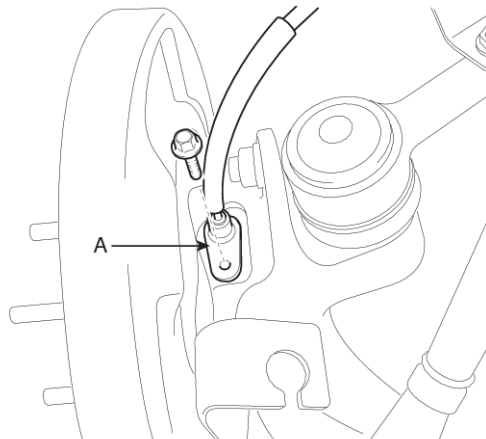

SHMDS8026D

9. Disconnect the rear shaft end(A) from knuckle.

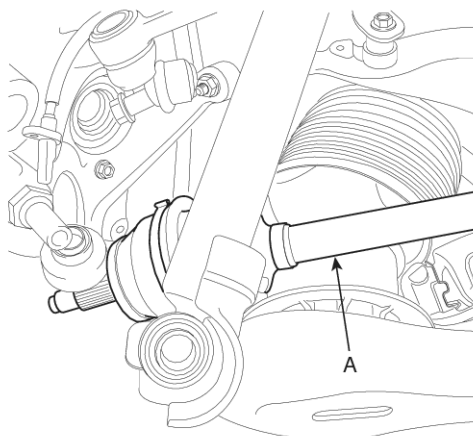

SHMDS8027D

# Rear Driveshaft Assembly

DS-27

10. Insert a pry bar (A) between the differential case and joint case, and separate the driveshaft (B) from the differential case.

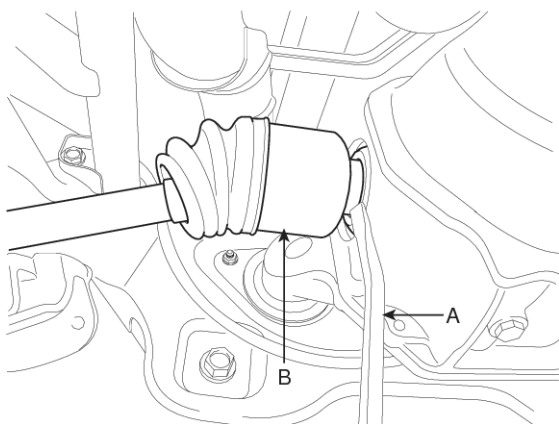

SHMDS8032D

### CAUTION

- Use a pry bar being careful not to damage the differential and joint.
- Do not insert the pry bar too deep, as this may cause damage to the oil seal.
- Do not pull the driveshaft by excessive force it may cause components inside the joint kit to dislodge resulting in a torn boot or a damaged bearing.
- Plug the hole of the differential case with the oil seal cap to prevent contamination.
- Support the driveshaft properly.
- Replace the retainer ring whenever the driveshaft is removed from the differential case.

### Inspection

1. Check the driveshaft boots for damage and deterioration.
2. Check the ball joint for wear and damage.
3. Check the splines for wear and damage.
4. Check the dynamic damper for cracks, wear and position.



SHMDS8315D

5. Check the driveshaft for cracks and wears.

### Inspection

1. Check the TSJ outer race, inner race, cage and balls for rust or damage.
2. Check splines for wear.
3. Check for water, foreign matter, or rust in the BJ boot.

### CAUTION

When the BJ assembly(A) is to be reused, do not wipe away the grease. Check that there are no foreign substances in the grease. If necessary, clean the BJ assembly(A) and replace grease.

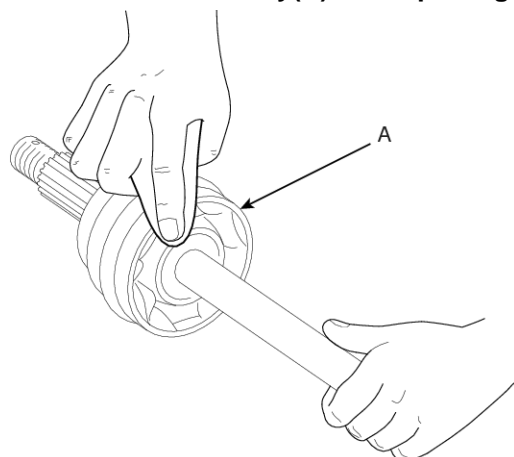

EIKD025A

## DS-28

## Driveshaft and axle

### Disassembly

#### ⚠CAUTION

- Do not disassemble the BJ assembly.
- Special grease must be applied to the driveshaft joint. Do not substitute with another type of grease.
- The boot band should be replaced with a new one.

1. Remove the TSJ. boot bands and pull the TSJ. boot from the TSJ. outer race.

- 1) Using a plier or flat-tipped (-) screwdriver, remove the LH boot band and LH TSJ. boot band from the driveshaft.
- 2) Remove RH boot band and RH TSJ. boot band in the same way of LH removal procedure.

#### ⚠CAUTION

**Be careful not to damage the boot.**

2. Remove the circlip(B) with a flat-tipped (-)screwdriver(A).

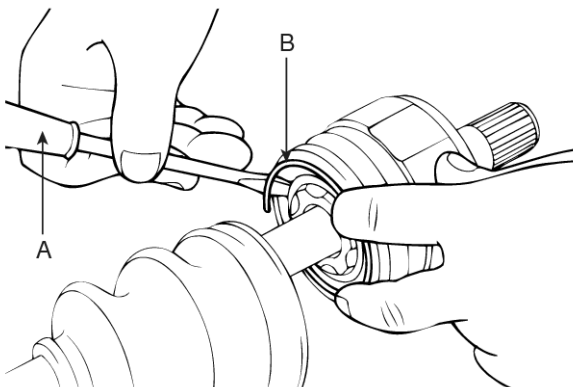

KIKD251B

3. Pull out the driveshaft from the TSJ. outer race.

4. Remove the snap ring(A) and take out the inner race(B), cage(C) and balls(D) as an assembly.

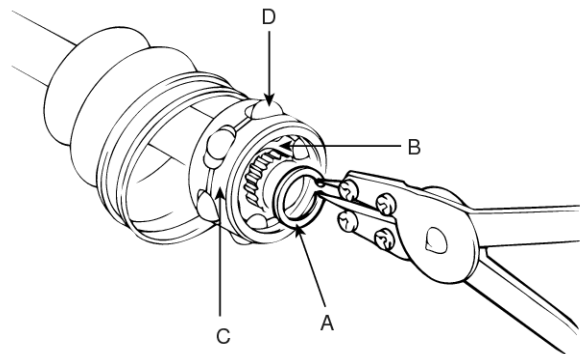

KIKD251C

5. Clean the inner race, cage and balls without disassembling.

6. Remove the BJ. boot bands and pull out the TSJ. boot and BJ. boot.

#### ⚠CAUTION

If the boot(A) is to be reused, wrap tape(B) around the driveshaft splines(C) to protect the boot(A).

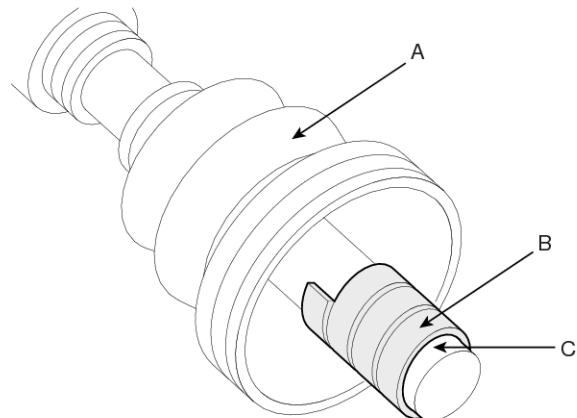

KXDDE14A

# Rear Driveshaft Assembly

DS-29

## Reassembly

1. Wrap tape around the driveshaft splines (TSJ. side ) to prevent damage to the boots.
2. Apply grease to the driveshaft and install the boots.
3. Apply the specified grease to the inner race(A) and cage(B). Install the cage(B) so that it is offset on the race as shown.

### ⚠ CAUTION

Use the grease included in the repair kit.

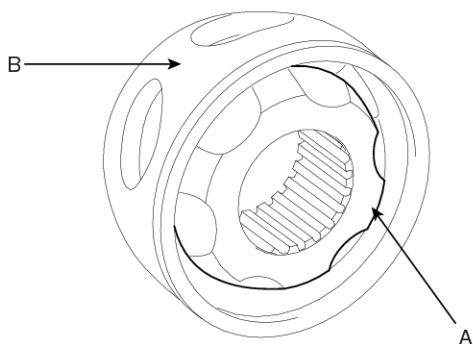

EIKD023A

4. Apply the specified grease to the cage and fit the balls into the cage.
5. Position the chamfered side(A) as shown in the illustration. Install the inner race on the driveshaft(B), and then the snap ring.

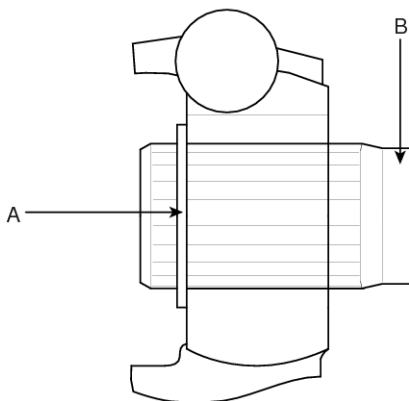

EIKD020A

6. Apply the specified grease to the outer race and install the BJ. outer race onto the driveshaft.
7. Apply the specified grease into the TSJ. boot and install the boot with a clip.
8. Tighten the TSJ. boot bands.
9. Add the specified grease to the BJ. as much as wiped away at inspection.
10. Install the boots.
11. Tighten the BJ. boot bands.
12. To control the air in the TSJ. boot, keep the specified distance between the boot bands when they are tightened.

**Distance (mm) :**  $678.4 +19.55$   
 $-11.8$

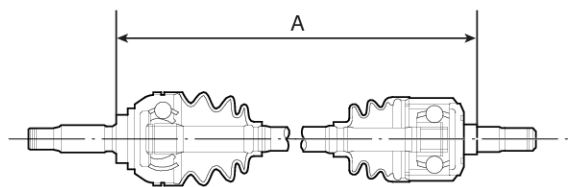

EIKD021A

## DS-30

## Driveshaft and axle

### Propeller Shaft Assembly

### Propeller Shaft

### Component location

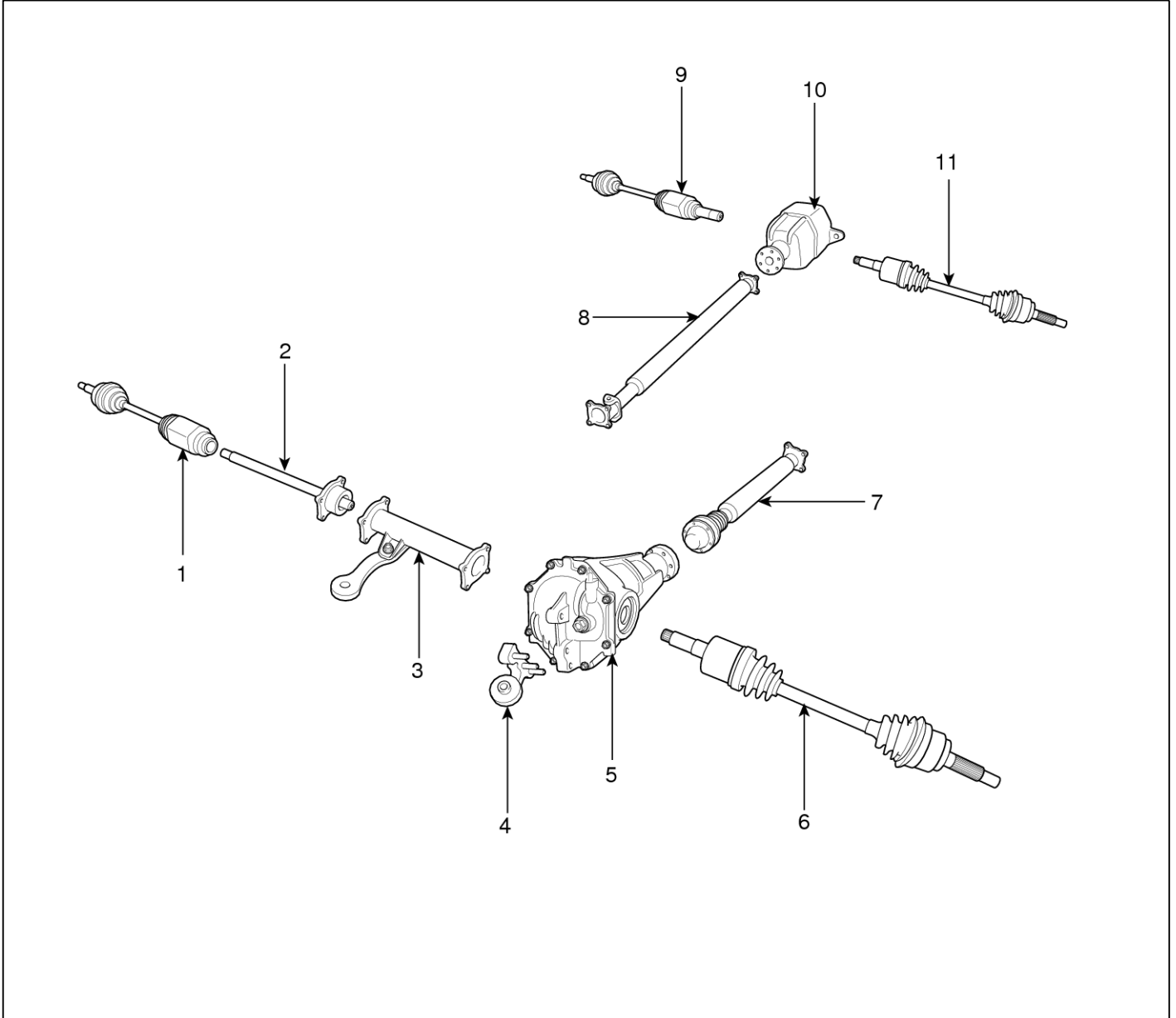

SHMDS8308D

1. Front driveshaft (RH)
2. Out shaft & bearing assembly
3. Outfoot shaft housing assembly
4. Diff mounting bracket
5. Front differential carrier assembly

6. Front driveshaft (LH)
7. Front propeller shaft
8. Rear propeller shaft
9. Rear drive shaft (RH)
10. Rear differential carrier assembly
11. Rear drive shaft (LH)

# Propeller Shaft Assembly

DS-31

## Inspection

### CV Joint and boots

1. Shift the transaxle to Neutral.
2. Raise the vehicle off the ground, and support it with safety stands in the proper locations.
3. Check the center bearing(A) for excessive play or rattle and rubber for rent. If the center bearing(A) has excessive play or rattle and rubber has rent, replace the propeller shaft assembly.

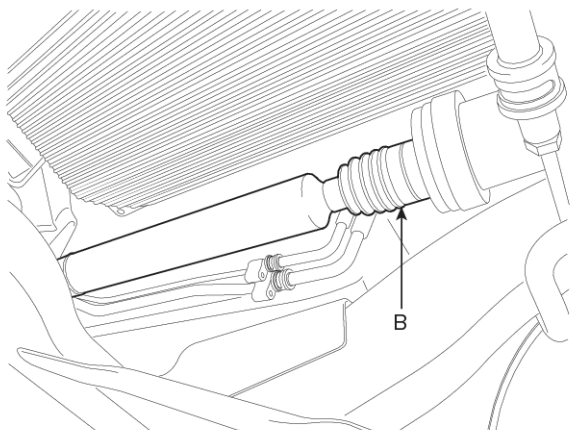

SHMDS8033D

4. Check the CV joint boot(B) for damage and deterioration. If the boot is damaged or deteriorated, replace the propeller shaft assembly.
5. Check the CV joint(C) for excessive play or rattle. If the CV joint have excessive play or rattle, replace the propeller shaft assembly.

## Propeller shaft runout

1. Install a dial indicator with its needle on the center of front propeller shaft or rear propeller shaft.
2. Turn the propeller shaft slowly and check the runout. Repeat this procedure for the other propeller shaft.

**Front Propeller Shaft Runout : 0.3mm (0.012in.)**

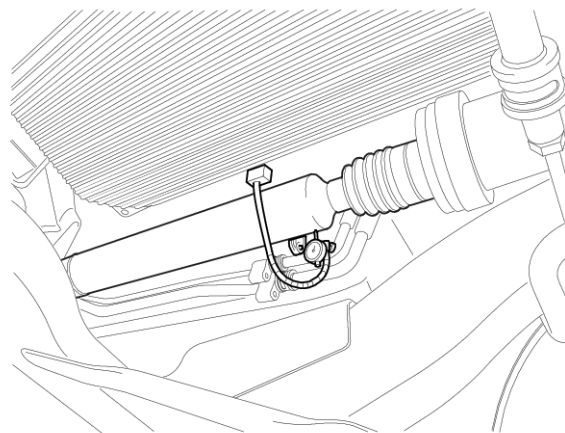

SHMDS8311D

**Rear Propeller Shaft Runout : 0.3mm (0.012in.)**

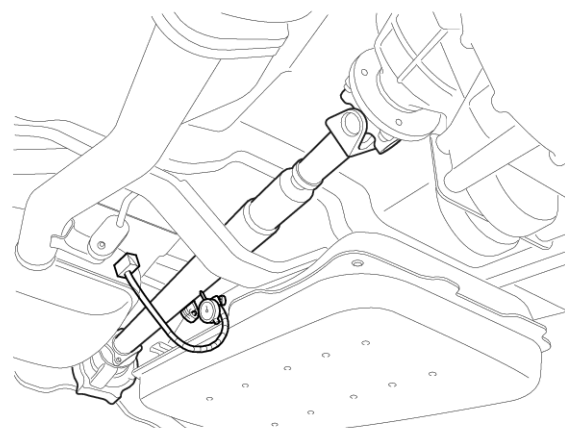

SHMDS8034D

3. If the runout on either propeller shaft exceeds the service limit, replace the propeller shaft assembly.

## DS-32

## Driveshaft and axle

### Replacement

1. After making a match mark on the rubber coupling and rear differential companion, remove the rear propeller shaft mounting bolts(A).

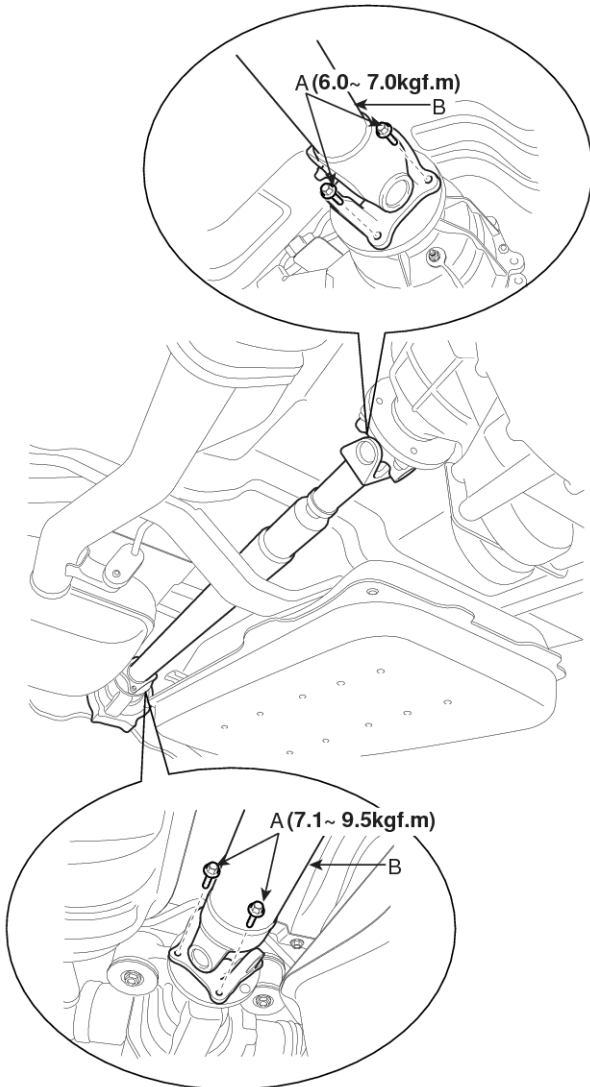

SHMDS8313D

2. After making a match mark on the flange yoke and transaxle companion, remove the front propeller shaft mounting bolts(A).

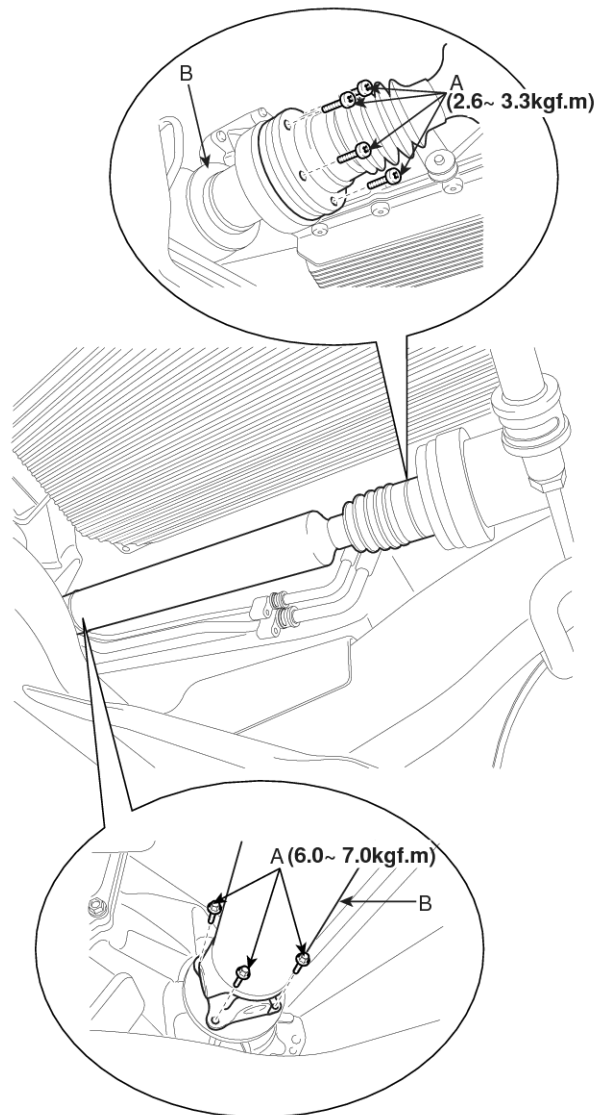

SHMDS8314D

### ⚠ CAUTION

Use the box wrench to prevent damage of bolt head when removing bolts(A).

3. Installation is the reverse of the removal procedures.

# Differential Carrier Assembly

DS-33

## Differential Carrier Assembly

### Front Differential Carrier(4WD)

#### Components

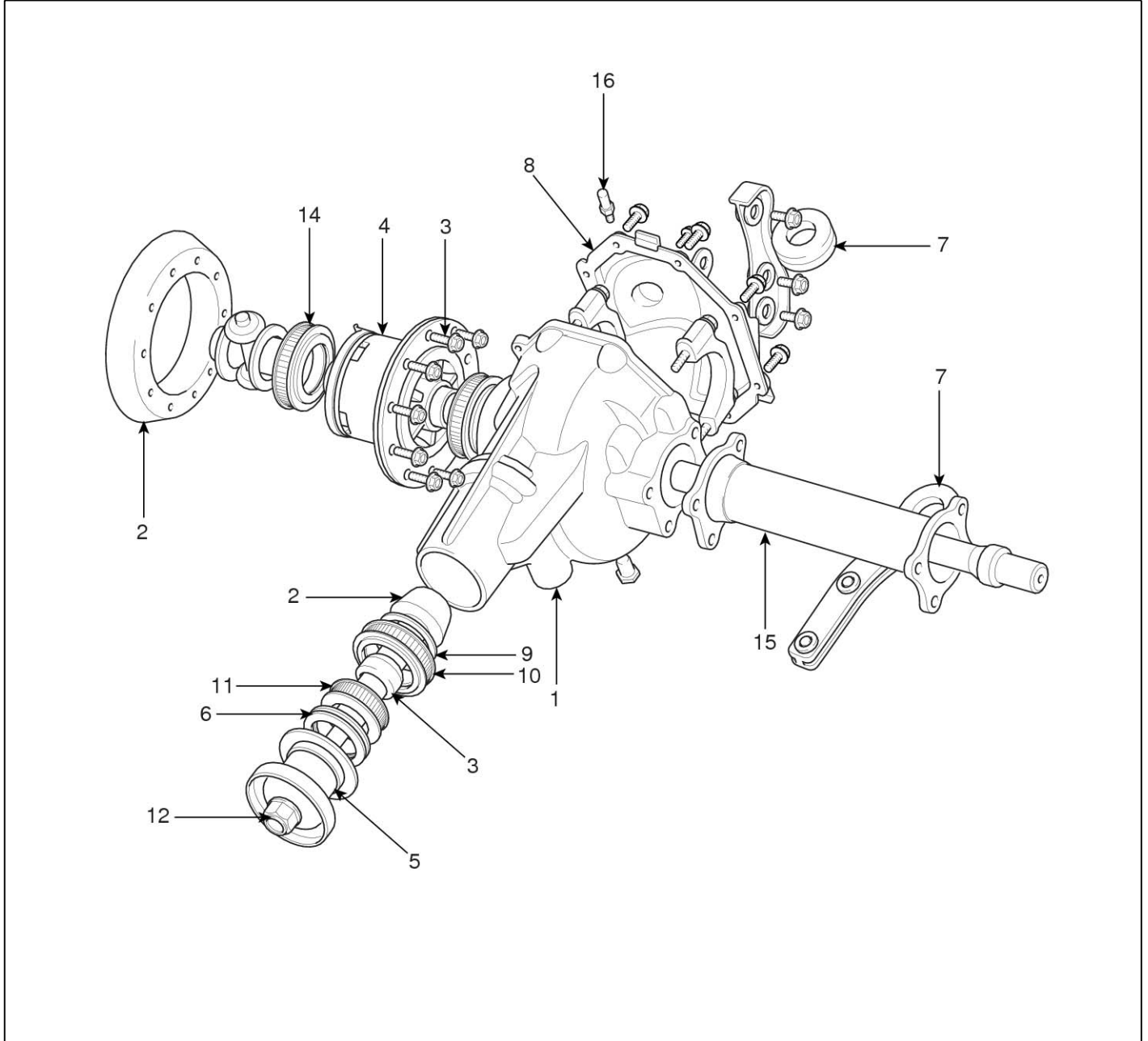

SHMDS8306D

- |                       |                          |                       |
|-----------------------|--------------------------|-----------------------|
| 1. Carrier Sub assy   | 7. Diff mounting bracket | 12. Lock nut          |
| 2. Pinion & Gear assy | 8. Cover                 | 13. Bolt              |
| 3. Spacer             | 9. Shim                  | 14. Diff bearing      |
| 4. Diff case          | 10. Inner bearing        | 15. Shaft & Tube assy |
| 5. Flange assy        | 11. Outer bearing        | 16. Vent Plug         |
| 6. Oil Seal           |                          |                       |

# DS-34

# Driveshaft and axle

## Rear differential carrier

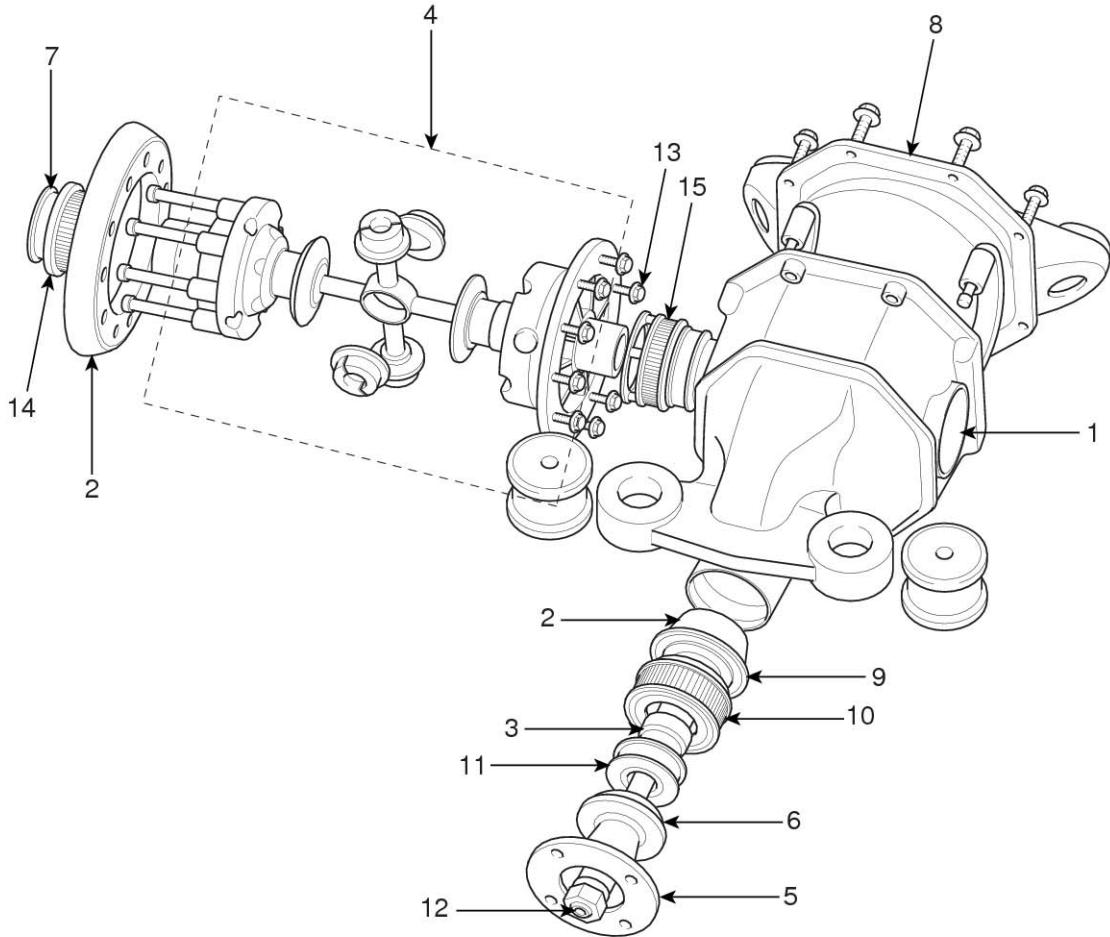

SHMDS8321D

- |                       |                         |                   |
|-----------------------|-------------------------|-------------------|
| 1. Carrier assy       | 6. Oil seal             | 11. Outer bearing |
| 2. Pinion & Gear assy | 7. C.V.J shaft Oil seal | 12. Lock nut      |
| 3. Spacer             | 8. Sub cover            | 13. Bolt          |
| 4. Diff case          | 9. Shim                 | 14. Diff bearing  |
| 5. Flange assy        | 10. Inner bearing       | 15. Spacer        |

# Differential Carrier Assembly

DS-35

## Replacement

### Front differential carrier

1. Drain the differential gear oil.
2. Remove the rear drive shaft.
3. Remove the propeller shaft.
4. Support the differential assembly(A) with the jack.

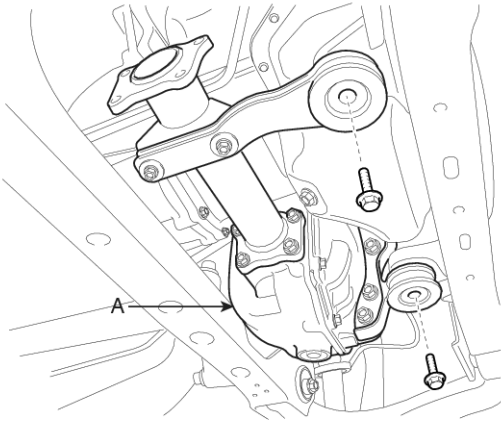

SHMDS9006L

5. Remove the inner shaft bearing bracket assembly(A) from differential assembly.

### Tightening torque :

88.2~107.8N.m(9~11Kgf.m,65.0~79.5lb.ft)

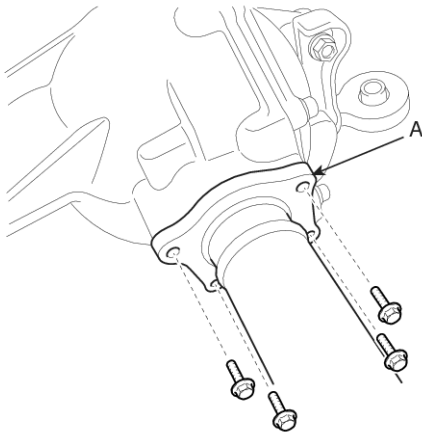

SHMDS8040D

### Tightening torque :

107.8~147.0N.m(11~15Kgf.m, 79.5~108.4lb.ft)

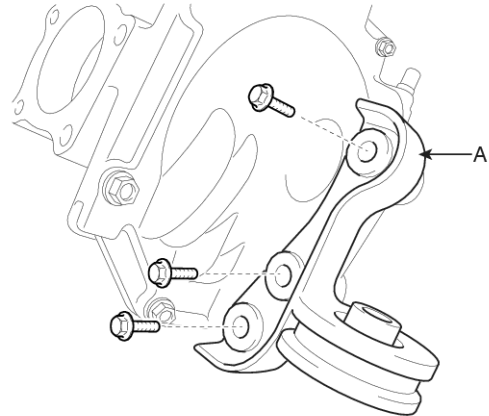

SHMDS9007L

6. After loosen the cover bolts(A), and remove the differential cover(B).

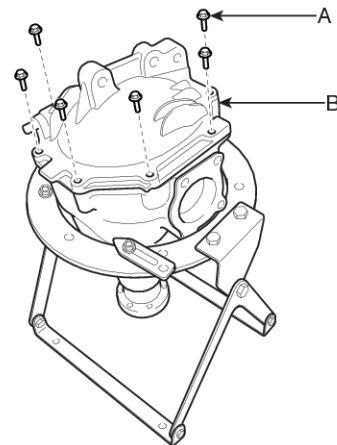

SHMDS9008L

7. Installation is the reverse of the removal procedures.

## DS-36

## Driveshaft and axle

### Rear differential carrier

1. Drain the differential gear oil.
2. Remove the rear drive shaft.
3. Remove the propeller shaft.
4. Support the differential assembly(A) with the jack.

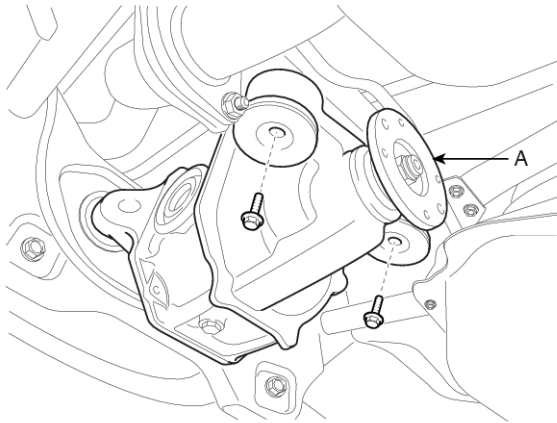

SHMDS9009L

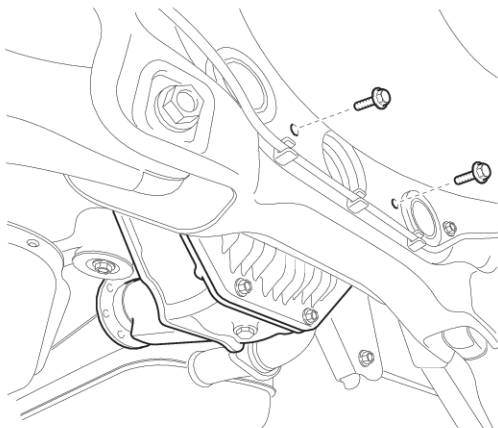

SHMDS8044D

5. After loosen the cover bolts(A), and remove the differential cover(B).

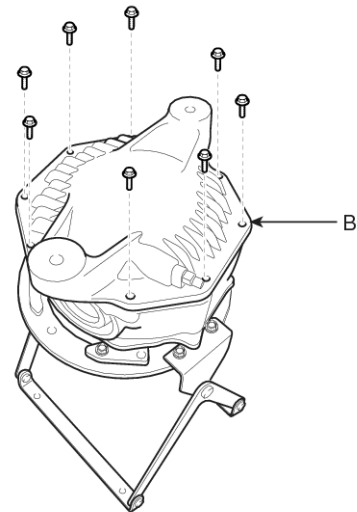

SHMDS8045D

6. Installation is the reverse of the removal procedures.

# Differential Carrier Assembly

DS-37

## Inspection

Install the differential carrier assembly(A) with the special tools(09517-43101 & 09517-43500). Then carry out the following inspection.

1. Check the final drive gear backlash by the following procedure.

- 1) Place the drive pinion and move the drive gear to check backlash is within the standard range.

### NOTICE

Measure at 4 points on the gear periphery.

**Standard value** : 0.10 ~ 0.15mm (0.0039 ~ 0.0059in.)

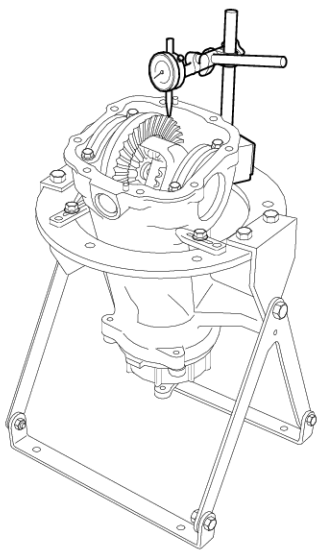

KIQE610B

2. Check the drive gear back-face lash by the following procedure.

- 1) Place a dial gauge on the back-face of the drive gear and measure the runout.

**Limit** : 0.05 mm (0.002 in)

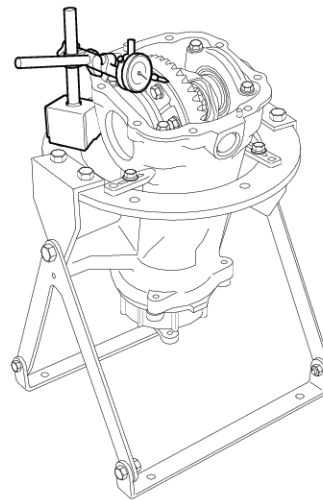

KIQE610C

- 2) If the runout is beyond the limit, check that there are no foreign substances between the drive gear and differential case and, that the bolts fixing the drive gear are not loose.

3. Check the differential carrier backlash by the following procedure.

- 1) Fix the side gear with a wedge so it cannot move and measure the differential gear backlash with a dial indicator on the pinion gear.

**Standard value** : 0 ~ 0.05 mm (0 ~ 0.002 in)

### NOTICE

Take the measurements at two places on the pinion gear.

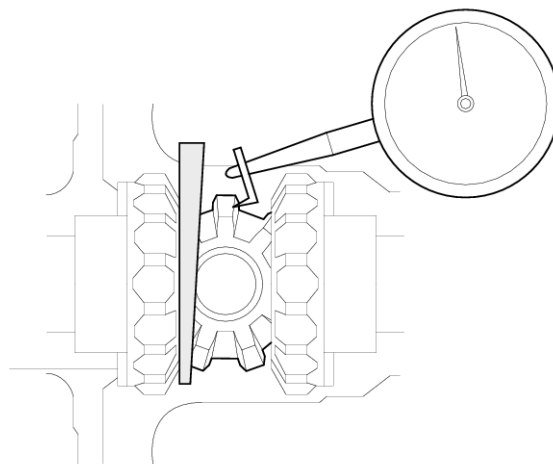

KISE610E

## DS-38

## Driveshaft and axle

- 2) If the backlash exceeds the limit, adjust using side bearing spacers.

### NOTICE

*If adjustment is impossible, replace the side gear and pinion gear as a set.*

4. Check the tooth contact of the final drive gear by the following procedure.

- 1) Apply the same amount of machine blue slightly to both surfaces of the drive gear teeth.

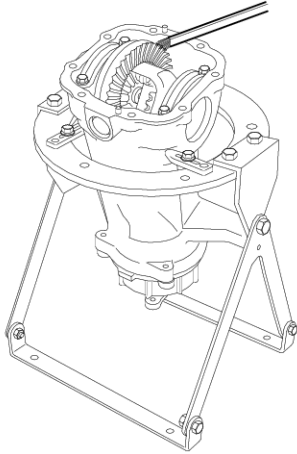

KIQE610D

- 2) Insert a brass rod between the differential carrier and the differential case, and then rotate the companion flange by hand (once in the normal direction, and then once in the reverse direction) while applying a load to the drive gear so that some torque (approximately 25~30Nm) is applied to the drive pinion.

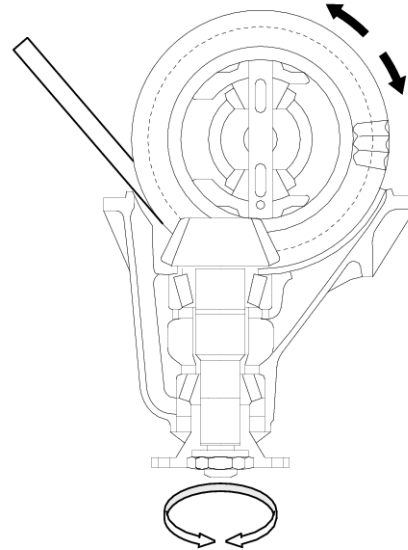

KISE610G

### CAUTION

**If the drive gear is rotated too much, the tooth contact pattern will become unclear and difficult to check.**

# Differential Carrier Assembly

DS-39

3) Check the tooth contact pattern.

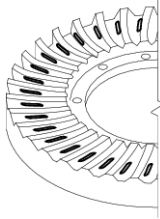
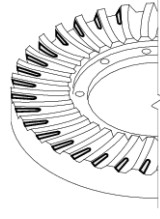
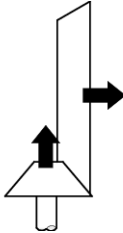
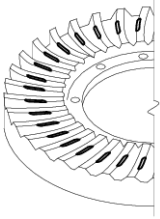
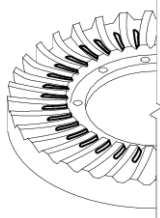
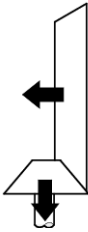
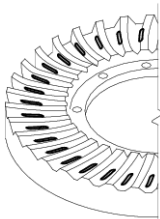
	Contact state		Solution
Standard contact	 <p>KISE610H</p>		
1. Heal contact	 <p>KISE650A</p>	<p>Increase the thickness of the pinion height adjusting shim, and position the drive pinion closer to the center of the drive gear.</p>	 <p>KISE630A</p>
2. Face contact	 <p>KISE650B</p>	<p>Also, for backlash adjustment, reposition the drive gear further from the drive pinion.</p>	
3. Toe contact	 <p>KISE650C</p>	<p>Decrease the thickness of the pinion height adjusting shim, and position the drive pinion further from the center of the drive gear.</p>	 <p>KISE630B</p>
4. Flank contact	 <p>KISE650D</p>	<p>Also, for backlash adjustment, reposition the drive gear closer to the drive pinion.</p>	

 NOTICE

- *Tooth contact pattern is a method for judging the result of the adjustment of drive pinion height and final drive gear backlash. The adjustment of drive pinion height and final drive gear backlash should be repeated until the tooth contact patterns are similar to the standard tooth contact pattern.*
  - *When you cannot obtain a correct pattern, the drive gear and drive pinion have exceeded their limits. Both gears should be replaced as a set.*
5. Check the oil seal for wear or damage.
  6. Check the bearings for wear or discoloration.
  7. Check the gear carrier for cracks.
  8. Check the drive pinion and drive gear for wear or cracks.
  9. Check the side gears, pinion gears and pinion shaft for wear or damage.
  10. Check the side gear spline for wear or damage.