



Compare brake disc with drum brake

Hasan Khodadoost *, Hossein Nazemian, Saba Ansari

1. Graduate Student, University of Science and Technology, hasan.khodadoost@yahoo.com
2. Graduate Student, University of Science and Technology, h.nazemian1995@gmail.com
3. Graduate Student, University of Science and Technology, Ansarisaba374@gmail.com

Abstract

Braking is a process which converts the kinetic energy of the vehicle into mechanical energy which must be dissipated in the form of heat. During the braking phase, the frictional heat generated at the interface disc and drum pads can lead to high temperatures. This phenomenon is even more important than the tangential stress as well, as the relative sliding speeds in contact is important. The objective of this study is to analyze the thermal behavior of the drum and ventilated brake discs of the vehicles using computing code ANSYS. The modeling of the temperature distribution in the disc and drum brake is used to identify all the factors and the entering parameters concerned at the time of the braking operation such as the type of braking, the geometric design of the disc and drum and the used material. The results obtained by the simulation are satisfactory compared with those of the specialized literature.

Key words: kinetic energy, mechanical energy, disc and drum, ANSYS

1. Introduction

The disc and drum brake is a device for slowing or stopping the rotation of a wheel. A brake disc (or rotor) usually made of cast iron or ceramic composites (including carbon, Kevlar and silica), is connected to the wheel and/or the axle.

According to the different functions of the braking system, two types of brakes are used in modern cars: drum brakes and disc brakes.

All cars use disc brakes on the front wheels, most cars use drum brakes on the rear wheels. In other words, the typical brake system consists of disc brakes in front and either disc or drum brakes in the rear connected by a system of tubes and hoses that link the brake at each wheel to the master cylinder. [1]

The basic components of drum brakes include: brake drum, an expander, pull back spring, a stationary back plate, two shoes with friction linings, an anchor point.

When using brakes, the driver needs to push the pedal, then the expander expands the shoes and presses them to the drum. So that the friction will appear, between the brake drum and the friction linings. Then the friction brakes the wheels, then the vehicle stops.

When the driver releases the pedal, the brakes are released, the pullback spring will retract the shoes, thus the wheels will be rotating freely. [1]

Main types of drum brakes include simplex drum brake (leading trailing shoe brake), duo-trailing shoe brake (two trailing shoe brake), double leading shoe brake, duo-duplex drum brake (duo two leading shoe brake), uni-servo drum brake, duo-servo drum brake.

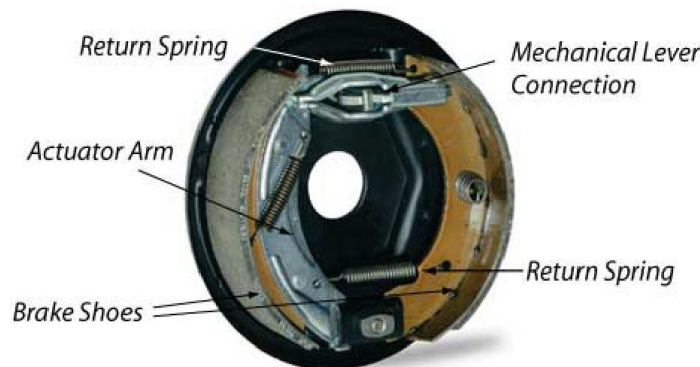

Figure 1 : Brake drum parts

Instead of a drum, the disc brake has a metal disc and a flat shoe or disc-brake pad, which is located on each side of the disc.

When the drivers step the pedals, the shoes squeeze the rotating disc to stop the car. The fluid from the master cylinder forces the pistons to move in, toward the disc. This action pushes the friction pads tightly against the disc. And then the friction between the shoes and disc slows and stops it. This provides the braking action. Pistons are made of either plastic or metal. [2]

There are three general types of a disc of brakes: floating-caliper type, the fixed-caliper type, and the sliding-caliper type.

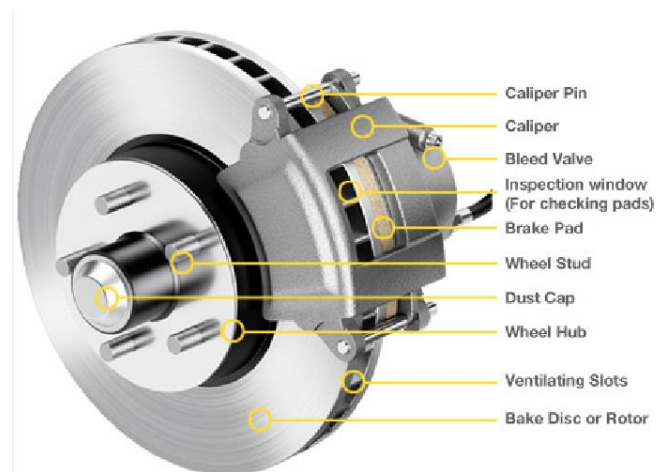

Figure 2 :brake disc parts

The main disadvantage of drum brakes is that the friction area is almost entirely covered by a lining, so most heat must be conducted through the drum to reach the outside air to cool. Because of being exposed to the air, the disc brakes radiate the heat to air easier, the disc brakes have a greater resistance to fade (fall-off in brake efficiency due to heat) than drum brakes. It means the disc could be operated continuously for a long period. [3]

And the disc brakes have better gradual braking efficiency. There are also some other advantages of disc brakes, such as: equal wear of the inboard and outboard brake pads, relatively constant brake factor performance with susceptibility to fading.

But the disc brakes also have some disadvantages. For example, the disc brake has a short brake pad life when used on heavy-duty commercial vehicles, it needs higher acquisition and operating costs, it will cause brake noise easily.

Meanwhile, drum brakes have more parts than disc brakes and are harder to service, but they are less expensive to manufacture, and they easily incorporate an emergency brake mechanism. The effective brake friction area of the drum brakes is bigger than that of disc brakes so that the drum brakes have higher braking efficiency. It is necessary for heavy-duty commercial vehicles. [3]

1-1- The advantages of disc brakes:

1. Disc brake requires less effort (brake torque) to stop the vehicle compare to drum brake.
2. It generates less heat compare to drum brake for the same brake torque.
3. It cools down faster compared to drum brakes.
4. If worn out brake shoes are not changed at the proper time it can cut the brake drum in a drum brake. Disc brake does not have such problem.
5. It is less likely to skid compare to drum brake in wet condition.
6. It is much safer than a drum brake in hard braking condition. Under such condition drum, brake can lock up the rear wheel.
7. It has a brake pad wear indicator which is not there in the drum brake.

1-2- Disadvantages of disc brake:



Autolibrary
**3rd International Conference on Applied Researches in
Science & Engineering**
19th December 2018 - Istanbul Turkey
Marmara University



1. It is expensive compared to drum brake.
2. More skills required to operate disc brake compared to drum brake that is the reason why some people are not comfortable with disc brake
3. If any air remains in disc brake system, it can cause accidents as the brake will not work effectively.
4. Disc brake assembly has more moving parts and much more complex than a drum brake.
5. It requires a lot of effort at maintenance front like brake fluid (bleeding), change of brake pads and etc compared to drum brake.

These brakes offer better stopping performance than comparable drum brakes, including resistance to "brake fade" caused by the overheating of brake components, and are able to recover quickly from immersion (wet brakes are less effective). Unlike a drum brake, the disc brake has no self-servo effect and the braking force is always proportional to the pressure placed on the braking pedal or lever. [4]

Discs have now become the more common form in most passenger vehicles, although many (particularly lightweight vehicles) use drum brakes on the rear wheels to keep costs and weight down as well as to simplify the provisions for a parking brake. As the front brakes perform most of the braking effort, this can be a reasonable compromise. [5]

2. calculation for disc and drum

For disc and drum brakes the normal force N is applied, using mechanical, pneumatic or hydraulic transfer unit. A servo unit raises the force F_{bet} applied by the driver:

$$N = i_A F_{Bet} \quad (1)$$

The factor i_A is the total transmission ratio of the brake. The friction force $R = \mu N$ acts on the rubbing surface. [6]

2-1- drum calculation

At each point of the contact area the coefficient μ of sliding friction is constant. The distributed friction force is caused by the pressure and are proportional to the coefficient of sliding friction:

$$dR = \mu dN \quad (2)$$

The braking moment can be calculated with the distance r of the contact point to the center of revolution. The summated friction force make up the peripheral force R_1 for the leading shoe and R_2 for the trailing shoe. Both act against the rotation of the drum with the lever arm r :

$$R_1 = \int_{-\alpha_1}^{\alpha_2} dR \quad (3)$$



$$R_2 = \int_{-\alpha_1}^{\alpha_2} dR \quad (4)$$

Therefore the force S_1 and S_2 act upon the rolls. The solution of the integrals results in a relationship between applied forces and the braking moment. Whith $\alpha_0 = \alpha_1 + \alpha_2$ the brake parameter C^* is:

$$C^* = \frac{R_1 + R_2}{S_1 + S_2} = 2 \frac{f(\alpha_0) \frac{a_0}{r}}{(f(\alpha_0) \frac{a_0}{r})^2 - \mu^2 r} \frac{h}{\mu} \quad (5)$$

$$f(\alpha_0) = \frac{\alpha_0 + \sin(\alpha_0)}{4 \sin(\frac{1}{2} \alpha_0)} \quad (6)$$

The finite element model is used, to calculate a more realistic distribution of the contact pressure, considering the elastic deformations of both the linings and the drum. [6]

2-2- disc calculation

Unlike the drum brake, the friction surfaces of disk brakes are planar. The main advantage of the disk brake is that the heat can be transferred into the environment directly over the free surfaces of the disk. Further improvements for the heat convection are gained by ventilation channels or holes in the friction ring. However, in this example a ventilated disk is considered. [7]

Normal forces are generated by the hydraulic pressure in order to press the brake pads against the disk. The piston presses the pad against the disk. A reaction takes place where the caliper transfers the force to the pad on the other side of the disk. The normal force for each pad is

$$N = P_k \cdot A_K \quad (7)$$

The tangential stress generated on the friction surface results in the friction forces on each side of the disk. With the coefficient μ of friction, this force is:

$$R = \mu \cdot N \quad (8)$$

As the friction forces act on both sides of the disk, the brake parameter C^* for this type of brakes is

$$C^* = \frac{2R}{N} = \frac{2\mu N}{N} = 2\mu \quad (9)$$

3. Thermal analyses

The thermal analysis is a primordial stage in the study in the study of the brake systems, because the temperature determines the thermomechanical behavior of the structure. In the braking phase, temperatures and thermal gradients are very high. This generations stress and deformations whose consequences are manifested by the appearance and the accentuation of cracks. It is then important to determine what precision the temperature field of the braking disc. A large amount of heat generated at the pad/disc or pad/drum interface during



Autolibrary
**3rd International Conference on Applied Researches in
Science & Engineering**
19th December 2018 - Istanbul Turkey
Marmara University



emergency braking indisputably evokes non-uniform temperature distributions in the domain of the rotor, whereas the pad element is constantly heated during mutual sliding. [8]

Drum and disc brake has a strong, complex and intense level of thermal stress and coupled wear while braking. Due to pressure, friction plates and drum or disc crushes while coming into contact with each other and cause severe friction. Work done by friction produces a huge amount of heat and temperature. The friction force is the cause of heat so it directly affects the heat transfer and conduction. The sudden rise of temperature changes the stiffness of friction plates, the hardness of brake drum and disc and the interfacial friction factors. Meanwhile, Uneven thermal deformation affects the surface of the drum and disc in brake which brings the change in the distribution of friction and contact pressure along with the wear attribute. [9] In turn, wear behavior changes the contact surface's state which often affects the distribution of contact pressure. Hence, the braking process is fully related to coupled stress, temperature and wear attributes.

To stop the wheel, friction material in the form of brake pads (mounted on a device called a brake caliper) is forced mechanically, hydraulically, pneumatically or electromagnetically against both sides of the disc or inside the brake drum. [9]

In this study, we will present a numerical modeling in three dimensions to analyze the thermal behavior of the drum and disc brake. The thermal calculation based on the finite element method will be carried out using software Ansys. [10]

The contact area between the pads and disc of brake components, heat is generated due to friction. For calculation of heat generation at the interface of these two sliding bodies, two methods are suggested on the basis of "law of conservation of energy which states that the kinetic energy of the vehicle during motion is equal to the dissipated heat after vehicle stop". [10]

1-3- design disc and drum

The ANSYS Workbench, together with the Workbench projects and tabs, provides a unified working environment for developing and managing a variety of CAE information and makes it easier for set up and work with data at a high level. Workbench includes the following modules "ANSYS Design Space" is referred to as Simulation "ANSYS APDL" is referred to as Design Modeler and "ANSYS Design explorer" referred to as Design explorer. [10]

a) FEM Model of Disc and drum Disc Brake

The finite element model of the disc and drum brake constructed for the dimensions the inner radius, outer radius and flange thicknesses of discs are as 0.13, 0.2 and 0.03m for cast iron and stainless steel respectively to both cases disc and drum. [11-13]



Figure 3 : (A) ventilated disc, (B) drum disc

b) Meshing Details

The goal of meshing in Workbench is to provide robust, easy to use meshing tools that will simplify the mesh generation process. The model using must be divided into a number of small pieces known as finite elements. Since the model is divided into a number of discrete parts, in simple terms, a mathematical net or "mesh" is required to carry out a finite element analysis. [11-13]

Table 1: meshing details for ventilated disc and drum disc

Models	Material Type	Number of Elements	Number of Nodes
Ventilated Disc	cast iron	118301	218595
Drum	cast iron	74231	35049

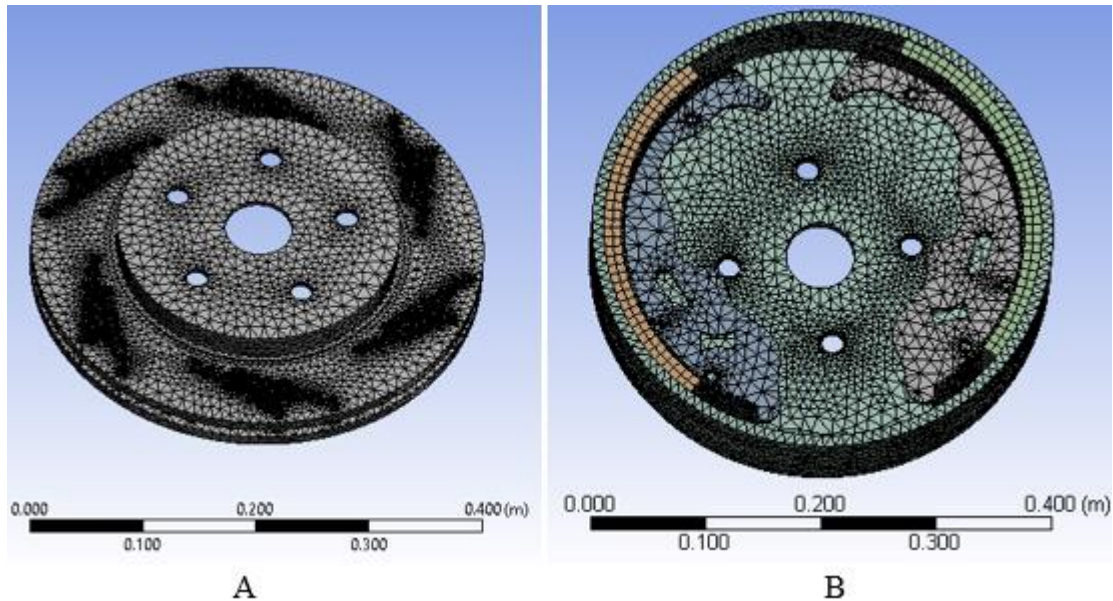

Figure 4: meshing for (A) Ventilated Disc (B) Drum

2-3- Results and discussions

To validate the present models, a transient thermal analysis behavior of disc brake was performed for the operating condition of the constant hydraulic pressure $P = 1\text{Mpa}$ and angular velocity $\omega = 50\text{ rad/s}$ (drag brake application) during 10 seconds. The ANSYS simulation is obtained in 6 repeated brake applications. One cycle is composed of braking time of 4sec and constant speed driving. The time step $\Delta t = 0.001\text{ sec}$ was used in the computations. In each process, the heat flux distribution on the friction surfaces after time $t=4\text{ sec}$ does scarcely occur and then the steady state is reached. The hydraulic pressure was assumed to linearly increase to 1MPa by 1.5 sec and then kept constant until 4sec. Also, the angular velocity was assumed to decay linearly and finally become zero at 4sec. The results obtained from analytical and FEM solutions are compared for both transient thermal and structural behavior of the model. Finally, the best model is suggested. [14]

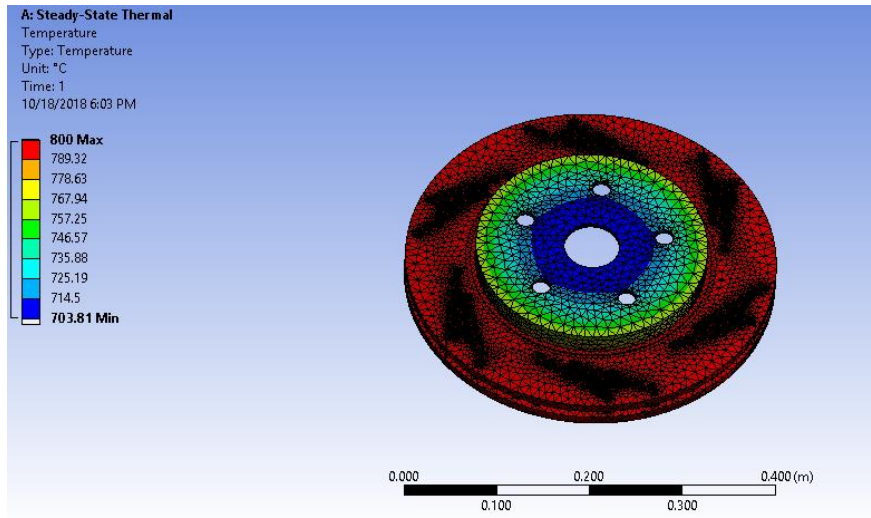

Figure 5: Thermal analysis for Ventilated Disc

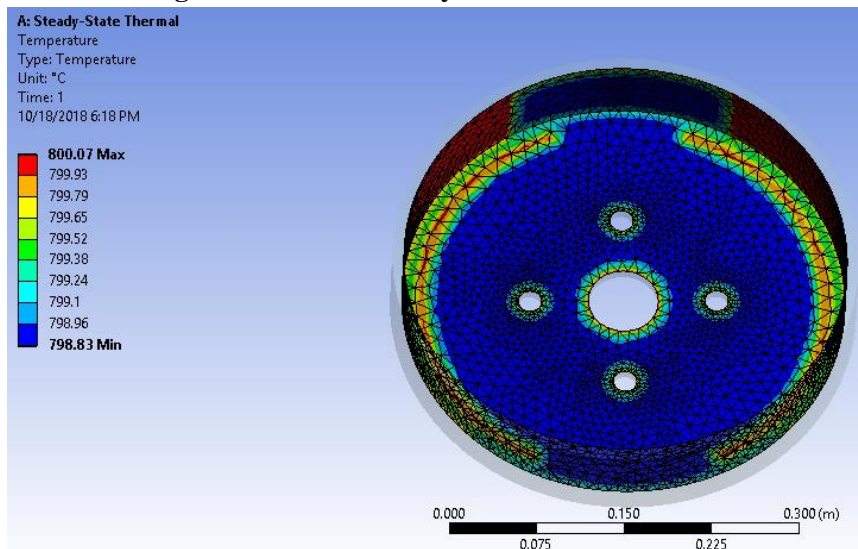

Figure 6: thermal analysis for drum disc

During each braking cycle, the temperature on surface of the disc is raises. During 1st braking, the temperature rises from ambient temperature 798°C to 800°C , The maximum temperature rise is indicated in red color and green color shows average temperature rise at the friction surface around the circumference of the disc as shown in above figures. [14-15]

5. Conclusion

The transient thermo elastic analysis of Disc and drum brakes in repeated brake applications has been performed. ANSYS software is applied to the thermo elastic contact problem with frictional heat generation. To obtain the simulation of thermo elastic behavior appearing in Disc and drum brakes, the coupled heat conduction and elastic equations are solved with contact problems. The effects of the friction material properties on the contact ratio of friction surfaces



Autolibrary
**3rd International Conference on Applied Researches in
Science & Engineering**
19th December 2018 - Istanbul Turkey
Marmara University



are examined and the larger influential properties are found to be the thermal expansion coefficient and the elastic modulus. It is observed that the orthotropic Disc and drum brakes can provide better brake performance than the isotropic ones because of uniform and mild pressure distributions. The present study can provide a useful design tool and improve the brake performance of Disc brake system.

References

1. Patekar, M. K., Patil, J., Palanivelu, S., & Bhat, B. (2017). Transient 1D Mathematical Model for Drum Brake System to Predict the Temperature Variation with Realistic Boundary Conditions. <https://doi.org/10.4271/2017-26-0299>
2. Papinniemi, A., Lai, J. C. S., Zhao, J., & Loader, L. (2002). Brake squeal: A literature review. *Applied Acoustics*, 63(4), 391–400. [https://doi.org/10.1016/S0003-682X\(01\)00043-3](https://doi.org/10.1016/S0003-682X(01)00043-3)
3. S.Ebrahimi-Nejad, & M.Kheybari. (2017). Brake System Design for Sports Cars. *International Journal of Automotive Engineering*, 7(4), 2570–2582.
4. Shaik, A. F. B., & Srinivas, C. L. (2012). Structural and thermal analysis of disc brake with and without crossdrilled rotar of race car. *International Journal of Advanced Engineering Research and Studies (IJAERS)*, Volume IV(Issue July-Sept), pp 39-43.
5. Natarajan, N., Vijayarangan, S., & Rajendran, I. (2007). Fabrication, testing and thermal analysis of metal matrix composite brake drum. *International Journal of Vehicle Design*, 44(3/4), 339. <https://doi.org/10.1504/IJVD.2007.013648>
6. Hohmann, C., Schiffner, K., Oerter, K., & Reese, H. (1999). Contact analysis for drum brakes and disk brakes using ADINA. *Computers and Structures*, 72(1), 185–198. [https://doi.org/10.1016/S0045-7949\(99\)00007-3](https://doi.org/10.1016/S0045-7949(99)00007-3)
7. Belhocine, A., & Bouchetara, M. (2012). Thermal analysis of a solid brake disc. *Applied Thermal Engineering*, 32(1), 59–67. <https://doi.org/10.1016/j.applthermaleng.2011.08.029>
8. Shahid, E., Wang, X., Fan, Z., & Gui, L. (2018). Numerical Simulation of the Stress, Temperature & Wear Behaviours of the Drum Brake. *IOP Conference Series: Materials Science and Engineering*, 398, 012018. <https://doi.org/10.1088/1757-899X/398/1/012018>
9. Abhang, S. R., & Bhaskar, D. P. (2014). Design and Analysis of Disc Brake. *International Journal of Engineering Trends and Technology*, 8(4), 165–167. <https://doi.org/10.13140/RG.2.2.32622.82245>
10. Nemade, A. W., & Telang, S. A. (2018). Effect of Heat Conduction on Friction Pad Life in Disk Braking System, 13(5), 1–4.
11. Galindo-Lopez, C. H., & Tirovic, M. (2008). Understanding and improving the convective cooling of brake discs with radial vanes. *Proceedings of the Institution of Mechanical Engineers, Part D: Journal of Automobile Engineering*, 222(7), 1211–1229. <https://doi.org/10.1243/09544070JAUTO594>
12. Qi, H. S., & Day, A. J. (2007). Investigation of disc/pad interface temperatures in friction braking. *Wear*, 262(5–6), 505–513. <https://doi.org/10.1016/j.wear.2006.08.027>
13. Nejat, A. (1980). Health Services Administration--Maternal and child health/crippled children's service program; policy statement on third-party reimbursement for services to mothers and children. General notice. *Federal Register*, 45(130), 45337. <https://doi.org/10.1115/1.4004931>



Autolibrary
**3rd International Conference on Applied Researches in
Science & Engineering**
19th December 2018 - Istanbul Turkey
Marmara University



14. Day, A. J., Ho, H. P., Hussain, K., & Johnstone, A. (2009). Brake system simulation to predict brake pedal feel in a passenger car. Agenda, 4970. <https://doi.org/10.4271/2009-01-3043>
15. Das, A. D., Raj, V. C. R., Preethy, S., & Bharani, G. R. (2013). Structural and Thermal Analysis of Disc Brake in Automobiles. International Journal of Latest Trends in Engineering and Technology, 2(3), 18–25.
16. Thilak, V. M. M., Krishnaraj, R., Sakthivel, M., Kanthavel, K., G, D. M. M., & Palani, R. (2011). Transient Thermal and Structural Analysis of the Rotor Disc of Disc Brake. International Journal of Scientific & Engineering Research, 2(8), 2–5.